

NASA/CR-1998-207669

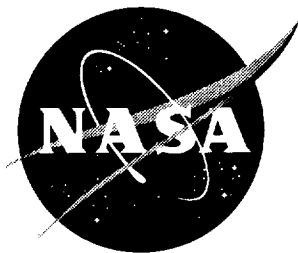

Development of a Flexible Seal for a 60 psi Cryogenic Pressure Box

David E. Glass
Analytical Services & Materials, Inc., Hampton, VA

National Aeronautics and
Space Administration

Langley Research Center
Hampton, Virginia 23681-2199

Prepared for Langley Research Center
under Contract NAS1-96014

May 1998

The use of trademarks or names of manufacturers in this report is for accurate reporting and does not constitute an official endorsement, either expressed or implied, of such products or manufacturers by the National Aeronautics and Space Administration or by Analytical Services & Materials, Inc.

Available from the following:

NASA Center for AeroSpace Information (CASI)
7121 Standard Drive
Hanover, MD 21076-1320
(301) 621-0390

National Technical Information Service (NTIS)
5285 Port Royal Road
Springfield, VA 22161-2171
(703) 487-4650

Development of a Flexible Seal for a 60 psi Cryogenic Pressure Box

David E. Glass
Analytical Services & Materials, Inc., Hampton, VA 23666

Abstract

A cryogenic pressure box test facility has been designed and fabricated for use at NASA Langley Research Center (LaRC) to subject 5 ft x 6 ft curved panels to cryogenic temperatures and biaxial tensile loads. The cryogenic pressure box is capable of testing curved panels down to -423°F (20K) with 52 psig maximum pressure on the concave side, and elevated temperatures and atmospheric pressure on the convex surface. The key challenge in the design and fabrication of the pressure box was the development of a seal that could remain flexible at -423°F and contain 60 psi gaseous helium as the pressurization gas. A C-shaped seal was developed using a Gore-tex® woven fabric. Mechanical testing of the fabric at ambient and elevated temperature, liquid nitrogen temperature, and liquid helium temperature demonstrated the strength and creep resistance of the material over the desired operating range. A small scale cryogenic pressure box was used to test prototype seals at cryogenic temperatures and at pressures up to 60 psi. Preliminary tests indicated that excessive leakage was present through the seal. As a result, an aluminized mylar liner was placed inside the Gore-tex® seal to reduce leakage through the seal. The final seal configuration resulted in minimal pressure loss during seal testing.

Introduction

A new reusable launch vehicle (RLV) is being designed and fabricated by Lockheed Martin that will be a single-stage-to-orbit (SSTO) vehicle. One of the primary hurdles to overcome in the successful operation of an RLV is the design and fabrication of the cryogenic tanks, shown in Figure 1 on a drawing of the vehicle. Both liquid oxygen (LOX) and liquid hydrogen (LH2) tanks must be built that are light weight, can carry the structural and thermal loads, and can contain the cryogenes.

To test cryogenic tank designs, a cryogenic pressure box was designed and fabricated that will enable full scale representative panels to be tested at actual operating conditions and loads (5 ft x 6 ft panels at -423°F (LH2 temperature) with an internal pressure of 52 psig) [1-3]. The pressure box, shown schematically in Figure 2, located at the NASA Langley Research Center (LaRC), will subject curved, stiffened panels to biaxial tensile loads by applying pneumatic pressure on the inside surface of the panel and tensile loads on the edges of the panel. The tensile load in the circumferential direction (hoop load) of the panel will be reacted through rods with turnbuckles that will be attached to the frames and skin of the panel. The tensile load in the axial direction of the panel will be applied by means of four hydraulic actuators. In addition to the applied structural loads and the cryogenic temperatures, the outer surface can be heated to approximately 1000°F.

A schematic of the pressure box is shown in Figure 2. The test panel covers the top of the pressure box. Fingers, not all of which are shown in the figure, transfer

mechanical loads from the hoop and axial load plates to the test panel. The C-seal is connected to fingers below the test panel and seals the region between the test panel and the transition channel. The transition channel is the top portion of the pressure box. Several other components shown in the figure are the cryogen supply lines, the cooling plates, and the fan motors.

In the design of the cryogenic pressure box, the seals development was the most challenging issue. Due to the biaxial loads and the thermal expansion and contraction of the test panels from the thermal loads, the test panel must be able to move relative to the pressure box. The relative movement requirement necessitated a flexible seal. The seal must remain flexible down to -423°F and be able to carry the pressure loads. Preliminary searches for potential existing seals turned up empty. As a result, a seal development effort was undertaken in parallel with the pressure box fabrication.

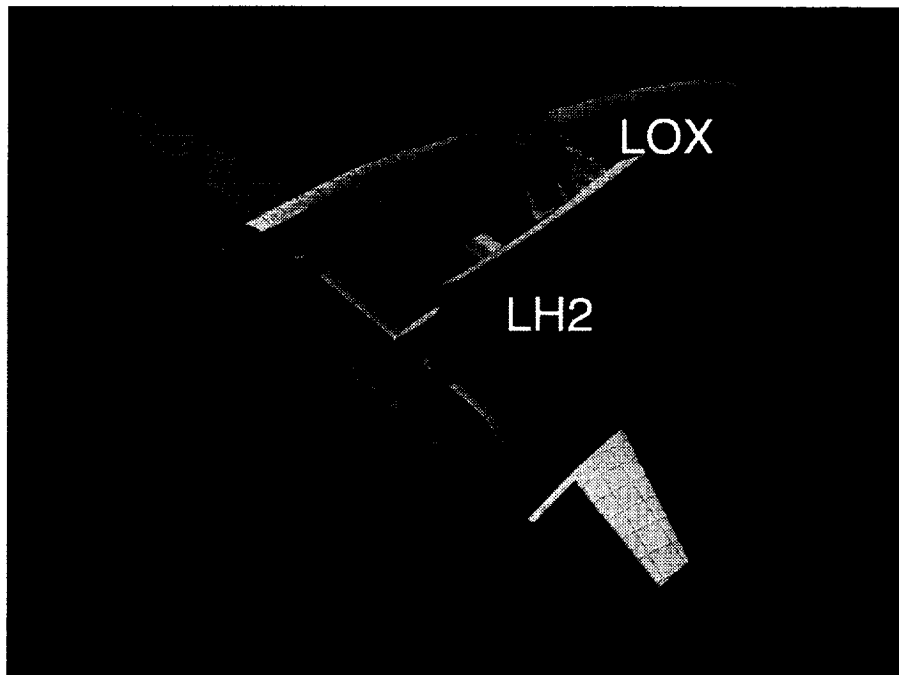

Figure 1: Conceptual drawing of the Lockheed Martin reusable launch vehicle showing the liquid hydrogen (LH2) and liquid oxygen (LOX) tanks.

Three seals were required to seal the pressure box, assuming the test panel has ring frames. Each of these seals are illustrated in Figure 3. One is a finger seal which seals the leak paths between the fingers and the C-seal. The second seal is the C-seal, which connects the panel to the transition channel, and the third seal is a tension rod seal that seals the penetration for the tension rod. Each of the different seals uses the same Gore-tex[®] material and is discussed in detail below.

The seal material that was chosen for each seal is a Gore-tex[®] fabric radome laminate, RA7943. (The radome material was suggested for use as a seal material by Applied Engineering Technologies, Woburn, MA who designed and fabricated the cryogenic pressure box.) The material is 100% fluoropolymer and is composed of 4 layers laminated together resulting in a total thickness of 0.014 in. Each layer of the laminate is made of different forms of polytetrafluoroethylene (PTFE or Teflon[®]). The fibers are woven in a 2 x 2 basketweave. The typical Mullen burst strength (ASTM D-

3786) is 800 psi. The typical breaking load (ASTM D-1682) is given in the cross machine direction as 300 lb/in. and in the machine direction as 350 lb/in. The manufacturer states that there is zero air permeability through the laminate. The material is capable of withstanding temperatures up to 550°F. Water entry pressure is stated by the manufacturer to be > 30 psi.

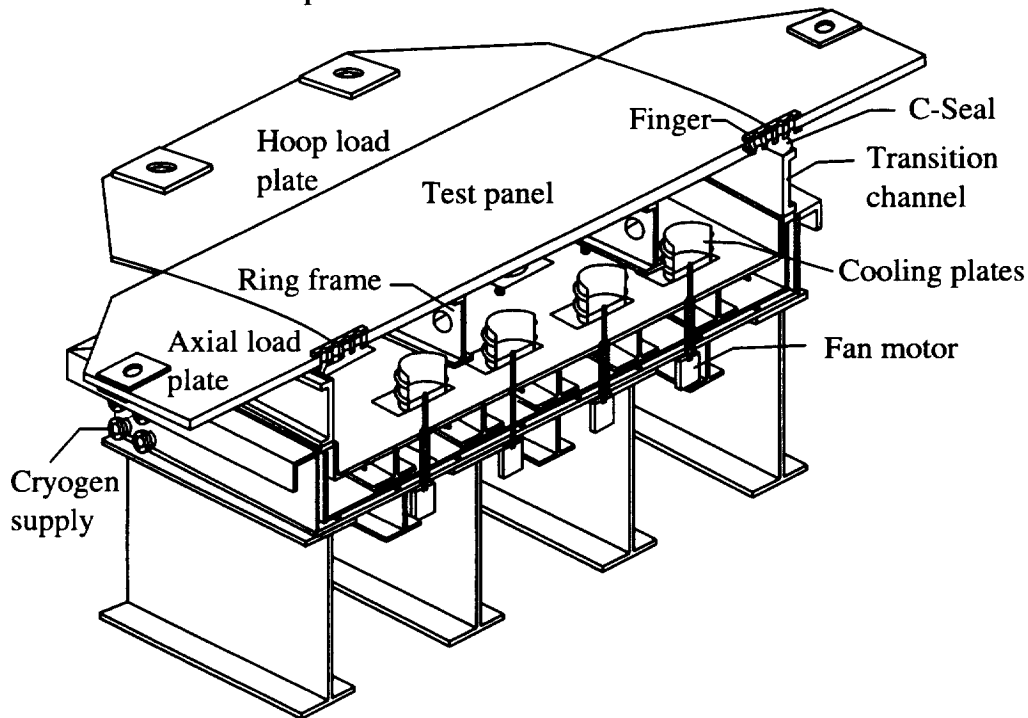

Figure 2: Schematic drawing of the cryogenic pressure box showing the location of the C-seals.

Due to the space between the fingers and the space between the load plate and the panel, a leak path exists that is sealed by the finger seal. The finger seal, indicated by number 1 in Figure 3, carries minimal tensile loads since the seal rests against the panel and fingers. The finger seal is bonded to the panel forward of the fingers with EA 9394 ambient temperature cure adhesive. A secondary finger seal, 2-in. wide, is bonded over the edge of the finger seal where it is bonded to the panel as a safety measure. The opposite end of the finger seal is bolted between bearing bars with the C-seal under the fingers.

The C-seal seals the region between the fingers and the transition channel. The C-seal must remain flexible at -423°F, carry the tensile loads generated by the 60 psi internal box pressure, and maintain minimal pressurization gas leakage. Due to the fact that the test panel must be allowed to move relative to the fingers (resulting from the biaxial loading), the fingers cannot be tightened against the test panel. Thus, the C-seal attachment to the fingers is through three bearing bars, the top one which is bolted to the finger with freedom to allow motion. The middle bearing bar is then bolted tightly to the upper bearing bar. The lower bearing bar, with the C-seal and finger seal sandwiched between the lower and middle bearing bars, is tightly attached to the middle bearing bar. The bottom of the C-seal is bolted down to the transition channel with another bearing bar.

A 1 7/8 in. diameter stainless steel tension rod will penetrate the transition channel, as shown in Figure 3, and attach to the ring frame of one panel planned for testing. Due

to the possibility of the test panel lifting up to 2 in. upon box pressurization, the hole where the tension rod penetrates must be able to allow for that vertical motion. A stainless steel bellows seal was initially considered. However, due to the magnitude of the required length (~36 in.) and diameter (~ 6 in.) of the bellows seal, a more compact sealing mechanism was required. It is anticipated that the tension rod seal will use the same seal material used for the C-seal and finger seal. However, the seal design has not been finalized and is thus not included in the figure.

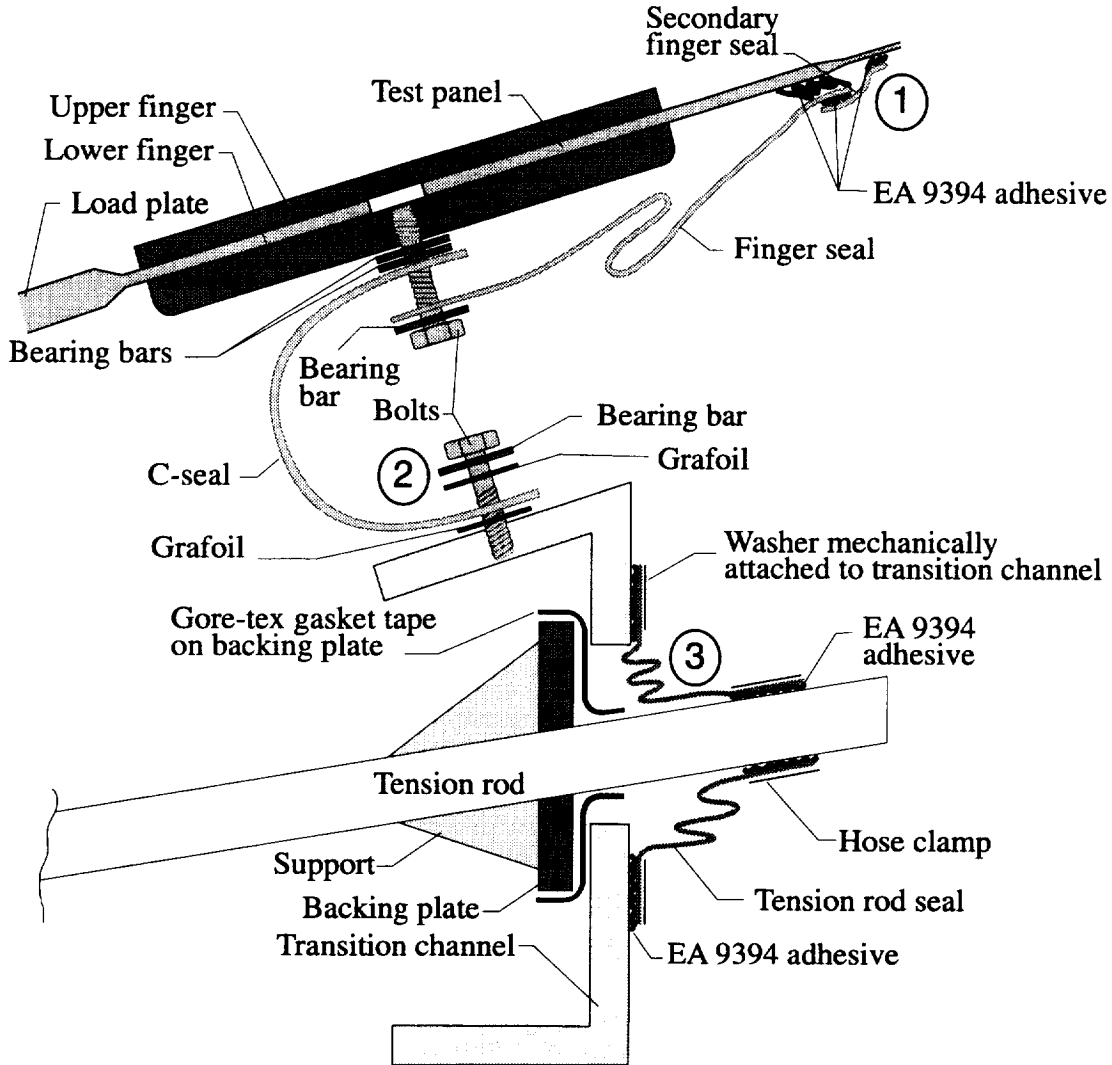

Figure 3: Schematic drawing of the cross-sectional view of the seals and the transition channel.

The current paper discusses the mechanical testing of the seal material and the testing of prototype C-seals. The finger seal and tension rod seal are not discussed further in this report. Strength and creep testing were performed on the material at ambient, cryogenic, and elevated temperatures. A small pressure box that was fabricated by Applied Engineering Technologies (AET), Woburn, MA was used to pressurize the seal to 60 psi at cryogenic temperatures. The seal development and testing are the subject of this paper.

Mechanical Testing of Seal Material

Tests were performed to determine the strength of the seal material when tested under several different loading conditions. Preliminary qualitative tests were performed to quickly learn a few characteristics of the seal material. These tests were later followed by static and creep testing in test machines at ambient, cryogenic, and elevated temperatures.

The gap between the transition channel and the fingers, which is the diameter of the C-seal, is anticipated to be about 3 in. The hoop stress in the seal can be related to the load per width of seal as tested in a test machine as given below. With a maximum pressure of 60 psi, the required strength of the seal material can be determined from

$$\frac{Pr}{t} = \frac{F}{A} = \frac{F}{wt}$$

$$Pr = F/w = 60 \text{ psi (1.5 in.)} = 90 \text{ lb/in.}$$

where P is the internal box pressure and r is the radius of the C-seal. Thus, a strength of 90 lb/in. is required for 60 psi with a 1.5 in radius C-seal.

Preliminary Testing

First, a 4-in-wide section of the material with two bolts, 2 in. apart, was loaded with dead weights. This test evaluated the resistance of the material to bolt pull-out. As the weight was added in increments of 5 lb, a continual pull out at the bolt hole was noticed. The test was stopped at 60 lb after the material had stretched about 0.5 in. behind both the top and bottom bolts. Next, the bolts were tightened with a wrench, sandwiching the seal material between aluminum plates on both the top and bottom. Dead weights were again used to apply a load. This time, 100 lb were applied with no pull out in the bolt region. The strength of the material was then evaluated in a test machine. A 4-in-wide strip of material was held between the hydraulic grips and loaded at a rate of 5 lb/min. At approximately 700 lb, the load rate began to decrease as the material began to stretch. The maximum load obtained was 747 lb. Finally, the RA7943 material was bonded between two aluminum plates at each end of the material. The aluminum plates were bolted together. The load from the bolts was the only pressure used for the bonding, which was done with Crest 3170 adhesive. In this test, the maximum load was 745 lb, but the material appeared to start stretching around 600 lb. After the test, the aluminum plates were separated from the material to which it was bonded. The shear strength of the bond between the Al and the RA7943 appeared to be good, but the peel strength was negligible. It appeared that there was a mechanical bond, but not a chemical bond, i.e., the adhesive filled in the region of the RA7943 between fibers, but did not chemically attach to the material. In the last two tests, the material was about 4 in. wide, resulting in a usable strength of approximately 150 lb/in.

Ambient and Cryogenic Temperature Static Testing

Due to the criticality of the strength on the seal material, further tensile tests were performed. Four different types of material were tested: gray radome material, white radome material, etched white radome material, and Gore Shield 50[®]. Both white and gray seal material are available from the manufacturer. The gray seal material is woven with white threads and gray threads perpendicular to each other. The gray and white

radome materials are very similar as far as properties for use in radomes. However, the strength of the two materials was not known. The white radome material was also tested in the etched condition since etching is beneficial for bonding. The final material tested was Gore Shield 50[®], which was a much heavier weight material than the radome material.

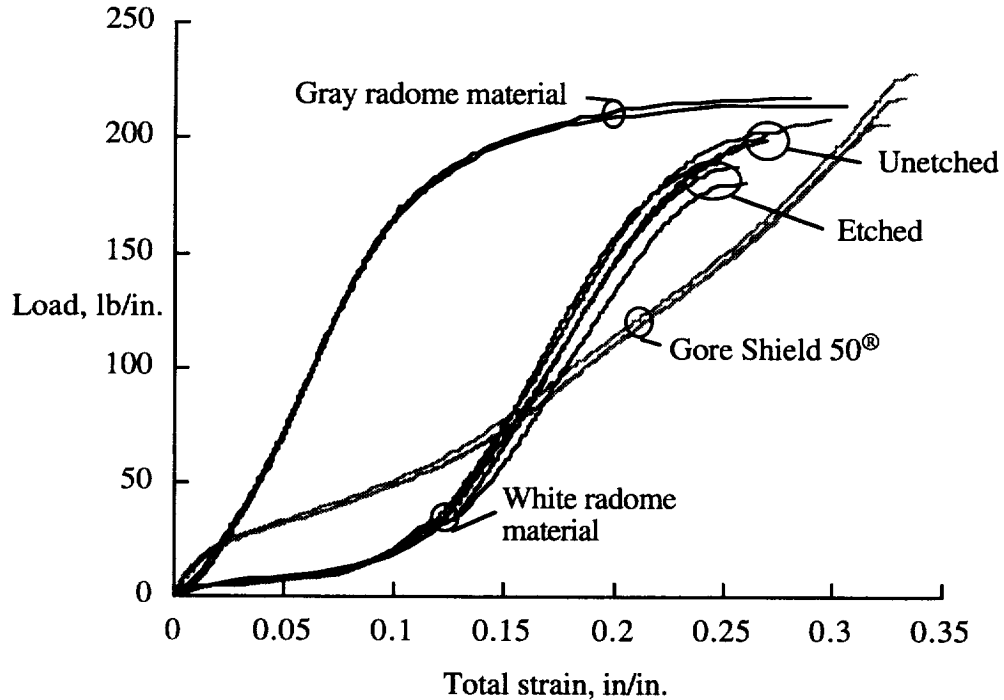

Figure 4: Load versus strain for the seal material under ambient temperature tensile testing.

Three samples of each specimen were tested. The gray radome material was loaded in the white thread direction, perpendicular to the gray threads. The samples were 4-in. wide with a test length of 3 in. Figure 4 shows the load per inch width of material versus the strain. The load per inch was obtained by dividing the total load by the initial 4-in. width of the samples. There was significant necking down of the samples, on the order of 0.5 in., as the load was increased. The test length was initially 3 in. and the strain shown in the figure is the total displacement divided by 3 in. The gray and white radome material and the Gore Shield 50[®] all failed at similar loads. However, the path each material followed to failure was radically different. The white radome material experienced a large initial strain at very low loads. After the initial strain, the white radome material experienced an increase in the strain similar to the gray radome material. The Gore Shield 50[®] material demonstrated a behavior unlike the radome material. Though it initially was thought that the Gore Shield 50[®] would be stronger due to its heavier weight (i. e., greater stiffness and thickness), it experienced significantly more strain with increased load than the gray radome material. Testing was also performed to evaluate the effect of etching on the strength of the white radome material. As can be seen in the figure, the etching decreased the failure load slightly, but had little effect on the properties prior to failure. Though the strain characteristics of the three different materials were very different, failure occurred in each at a strain of approximately 0.3 ± 0.05 in/in.

Tests were also performed at liquid nitrogen (LN2) and liquid helium (LHe) temperatures. For these tests, the entire fixture, along with the 1 in. x 7 in. specimen test area, was inserted into a dewar of the cryogen. The results are shown in Figure 5 for each of the LHe and LN2 exposed samples and ambient temperature controls. All specimens were loaded in the gray thread direction (load direction in actual seal) with a load rate of 100 lb/min/in. The ambient temperature controls failed at a strain of approximately 0.1 in/in. One of the specimens failed at the grip, while the other one failed between the grips. As can be seen in the figure, the specimens were much stronger when tested in LHe and LN2. All three of the LN2 tested specimens failed at the grip, while both of the LHe specimens failed between the grips. The LN2 and LHe samples experienced an offset in the load due to the contraction of the fixturing (due to cooling) in the cryogen during the test. The offset increased the load throughout the test, but was only known at the final load position. The offset increased the failure load of the LN2 samples to 398 lb/in. and 458 lb/in., while the LHe failure load was increased to 413 lb/in. and 423 lb/in. When the offset was included in the data, there appeared to be no significant difference between the LN2 and LHe test results. The LHe and LN2 samples also had a preload on them after installation in the fixture prior to testing. The preload was 50 lb/in. for the LN2 samples and 100 lb/in. for the LHe samples. The stroke (strain) was zeroed at the preload value, and thus any strain resulting from the preload was neglected. This may account for the different shape in the ambient temperature and cryogenic temperature tests, i.e., no inflection point at the early load values.

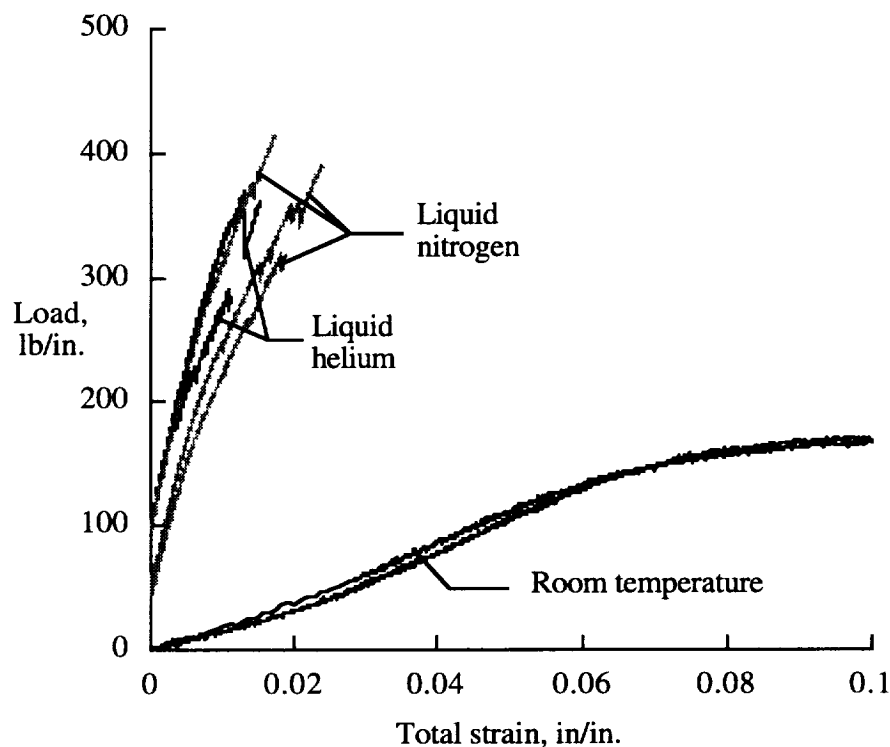

Figure 5: Load versus strain for 1-in-wide samples at ambient temperature, LN2 and LHe temperatures loaded in the gray thread direction with a load rate of 100 lb/min/in.

The seal will have several seams joining different pieces of fabric. The strength of the sewn joints was thus investigated. In the actual application, the seams will run parallel to the load, while in the test specimens, the seams were perpendicular to the load. Thus the test was conservative relative to the actual seal conditions. Figure 6 shows the

load versus strain for the 1-in-wide sewn joint samples. In each case, two pieces of the seal material were sewn together with a double seam, the two seams being approximately 0.25 in. apart. The load rate was again 100 lb/min/in., and the preload and offset are not included in the figure. However, unlike the prior tests, these samples were loaded in the white thread direction. The ambient temperature samples had a maximum load of approximately 50 lb/in, while the two LN2 samples had a maximum load of approximately 150 lb/in. The LN2 samples experienced much more oscillating in the data than in prior tests, and thus a curve fit is provided for the LN2 data. The cause of the noise in the data is uncertain. All of the joint tests failed in a similar manner regardless of the test temperature. In each case, the white thread (load carrying thread) broke at one of the seams. However, the gray threads, perpendicular to the load, separated approximately 0.3 in. from the seam. The reason for the gray threads separating away from the seam is unclear.

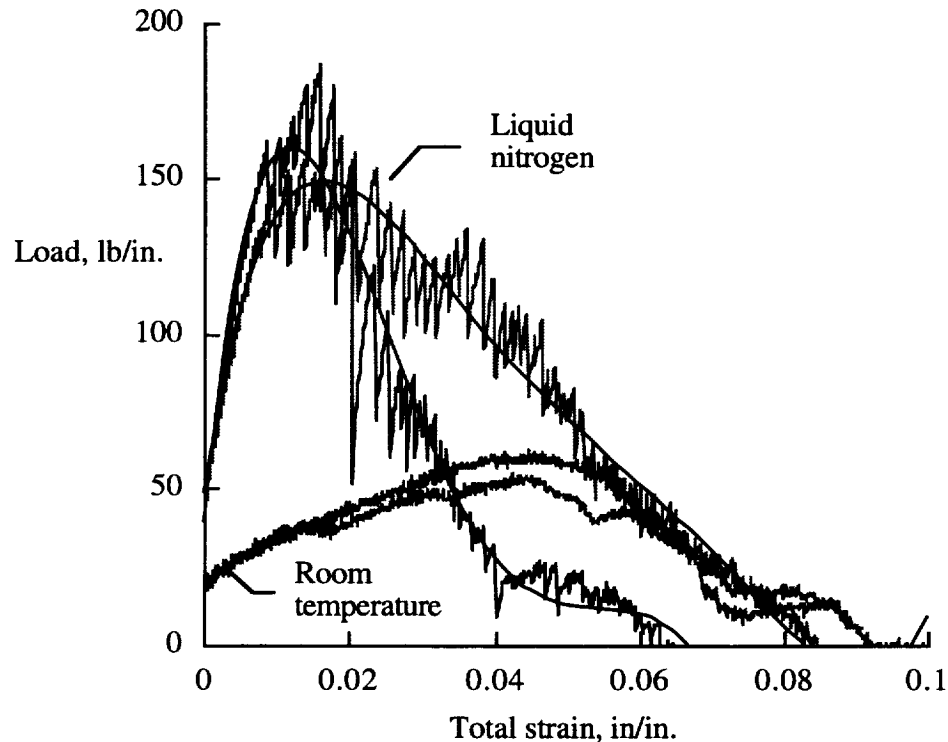

Figure 6: Load versus strain for 1-in-wide sewn joint samples at ambient temperature, LN2 and LHe temperatures loaded in the white thread direction with a load rate of 100 lb/min/in.

Ambient and Cryogenic Temperature Creep Testing

Creep testing was performed on the material at both cryogenic and ambient temperatures. During the creep testing, the samples were loaded at an initial load rate that was maintained until the desired load was obtained. At that point, a constant load was maintained. The initial load rate was found to influence the time to failure and the total strain and is thus included as a parameter in the testing.

Creep testing was performed on both 3-in-wide and 4-in-wide samples. Figure 7 shows the effect of the sample width on the creep of the samples. The samples were loaded in the gray thread direction with an initial load rate of 100 lb/min/in. until the desired test load (either 100 lb/in. or 125 lb/in.) was achieved. Then the samples were

held at that load level and the time varying strain was measured. From the figure, it can be seen that the width had an effect on the creep of the specimen. For both values of the maximum load, the 4-in-wide samples failed sooner and at a slightly lower strain. It should be pointed out that the 4-in-wide specimen at a load of 100 lb/in. was loaded at a slower initial rate than the other specimens. However, as will be seen later, a slower rate results in a longer time to failure and a higher total strain. Thus the 66 lb/min/in. initial loading rate provided a longer time and higher strain than would have been obtained with a 100 lb/min/in. initial loading rate as in the other specimens.

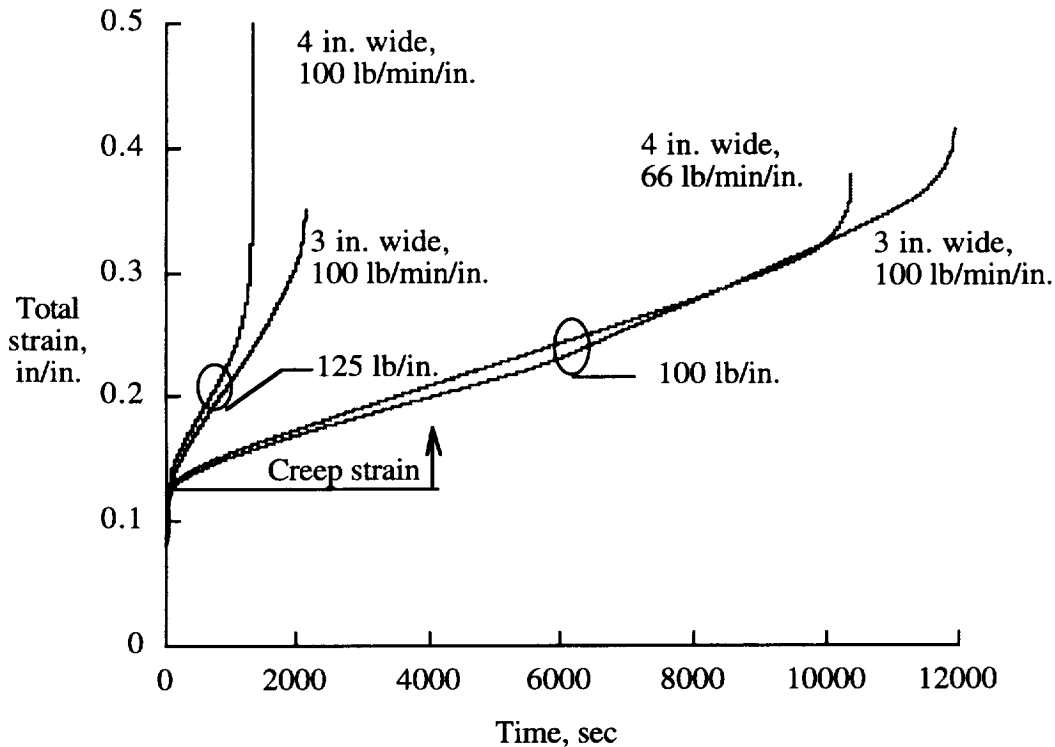

Figure 7: Effect of specimen width on creep for 3-in-wide and 4-in-wide samples loaded at ambient temperature in the gray thread direction with an initial load rate of 100 lb/min/in.

Figure 8 shows the effect of the test load on the creep for 3-in-wide samples. All the samples were loaded in the gray thread direction, and the load was increased at 100 lb/min/in. up to the test load condition. As expected, the time to failure increased as the load decreased. The decrease in load from 125 lb/in. to 100 lb/in. was in relatively uniform increments, but the time to failure increased non-linearly with each decrease in load. The failure strain for 100 lb/in. was slightly larger than for the higher load rates.

Samples with a width of 4 in. were also tested for creep, with the results shown in Figure 9. As in Figure 8, the time to failure increased non-linearly as the load was decreased. The samples were again loaded in the gray thread direction.

The effect of the initial load rate on the creep was also evaluated. Figure 10 shows the strain as a function of time for 3-in-wide samples with 100 lb/min/in. and 33.3 lb/min/in. initial load rate for a test load of 125 lb/in. Again, the samples were loaded in the gray thread direction and the testing was performed at ambient temperature. The slower initial load rate resulted in a longer time to failure and an increased strain capability.

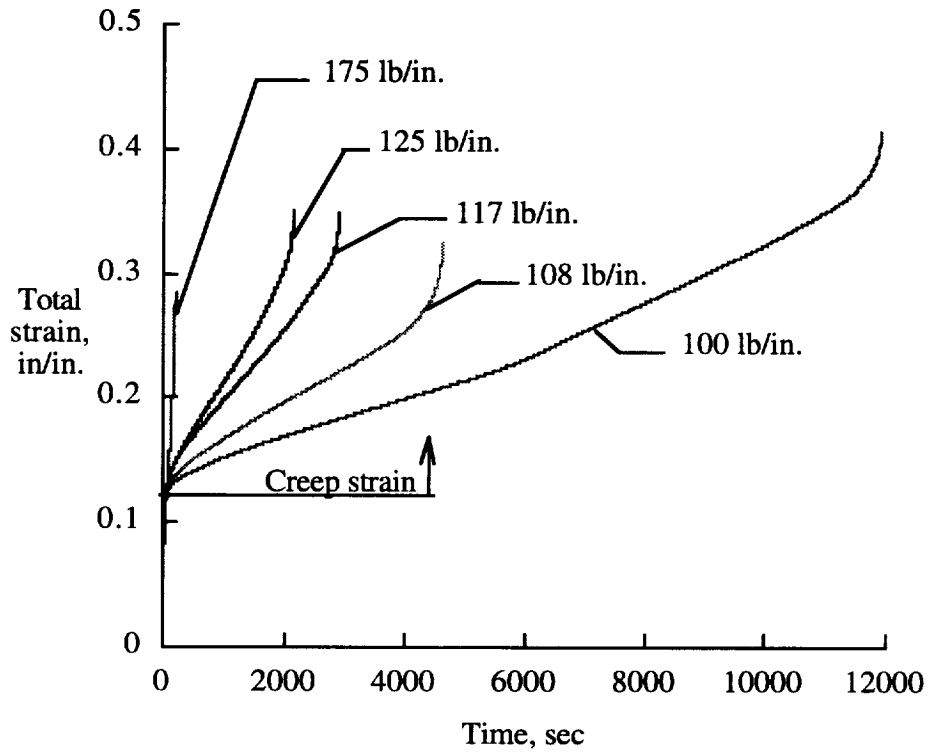

Figure 8: Effect of test load on creep of seal material with 3-in-wide samples loaded in the gray thread direction with an initial load rate of 100 lb/min/in.

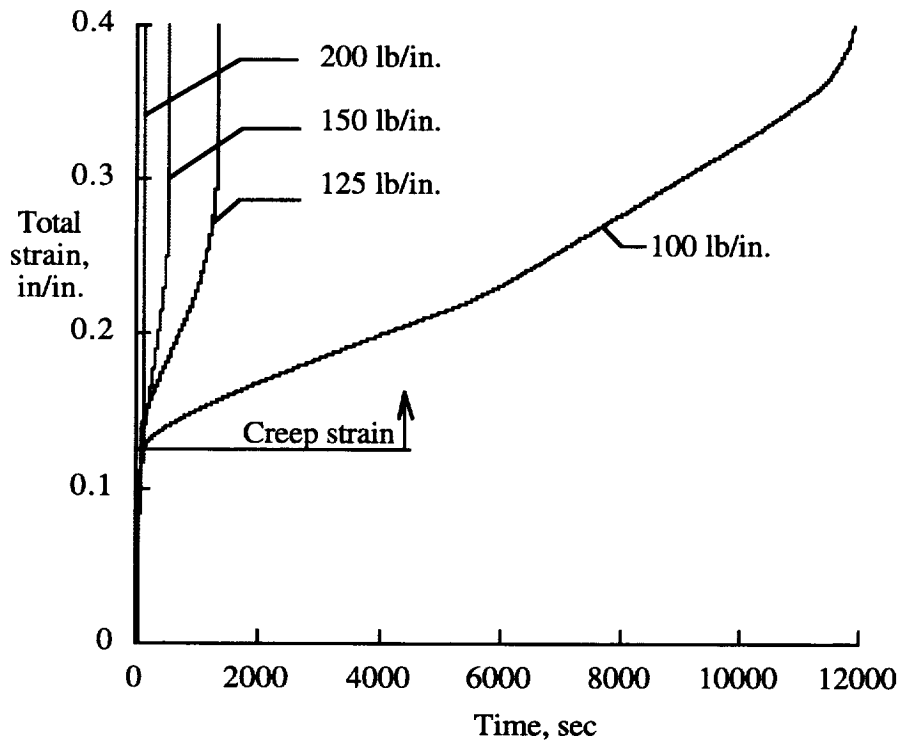

Figure 9: Effect of maximum load on creep of seal material with 4-in-wide samples loaded in the gray thread direction with an initial load rate of 100 lb/min/in.

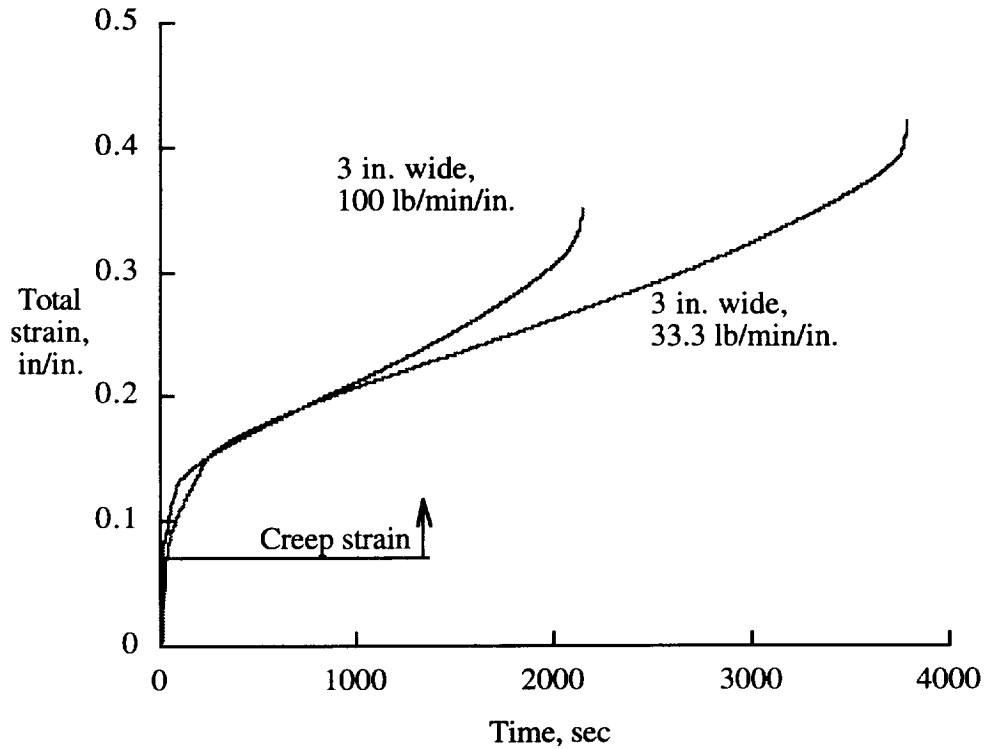

Figure 10: Effect of initial load rate on the creep of 3-in-wide specimens at 125 lb/in. loaded in the gray thread direction at ambient temperature.

Creep testing was also performed at LN2 and LHe temperatures and is summarized in Table 1. Since the slowest scan rate on the data acquisition was 1 scan/sec, the data was not recorded as a function of time due to the large volume of data. Two creep samples were tested in LN2. Unlike the static load tests where all three LN2 cooled specimens failed at one of the grips, both LN2 creep specimens failed between the grips. The first sample was tested at a test load of 200 lb/in. with an initial load rate of 100 lb/min/in. The sample failed after 1 hour with a creep strain of 0.0023 in/in. (i. e., the strain value was only from the point that 200 lb/in. was reached). The second sample tested in LN2 was tested at a load of 100 lb/i. and an initial load rate of 100 lb/min/in. The sample survived for 8 hr before failure. The creep strain after 8 hr was 0.0011 in/in. Both of these samples were loaded in the gray thread direction. One LHe creep test was performed. The preload was 100 lb/in. and the test load was 100 lb/in. After 105 minutes, the LHe dewar was empty. Testing was continued for another 170 minutes, after which the specimen still had not failed. The strain at that time was 0.0087 in/in. A creep test was also performed on one of the sewn samples in LN2. The preload and maximum load were 100 lb/in. After 5 hr, the specimen still had not failed and the strain was 0.0003 in/in.

Table 1: Results of Cryogenic Creep Testing on 1-in-Wide Specimens

Environment	Preload and Max load, lb/in.	Condition	Time, hr	Creep strain, in/in.
LN2 (Continuous)	200	Failed	1 hr	0.0023
LN2 (Continuous)	100	Failed	8 hr	0.0011
LHe (Continuous)	100	OK	4.6 hr	0.0087
LN2 (Sewn)	100	OK	5 hr	0.0003

Elevated Temperature Testing

Elevated temperature testing was also performed on the seal material. Since the testing was performed in different test machines than the prior ambient temperature testing, ambient temperature testing was also performed for baseline comparisons during the static testing. Static and creep testing was performed at ambient temperature, 150°F, 250°F, and 350°F.

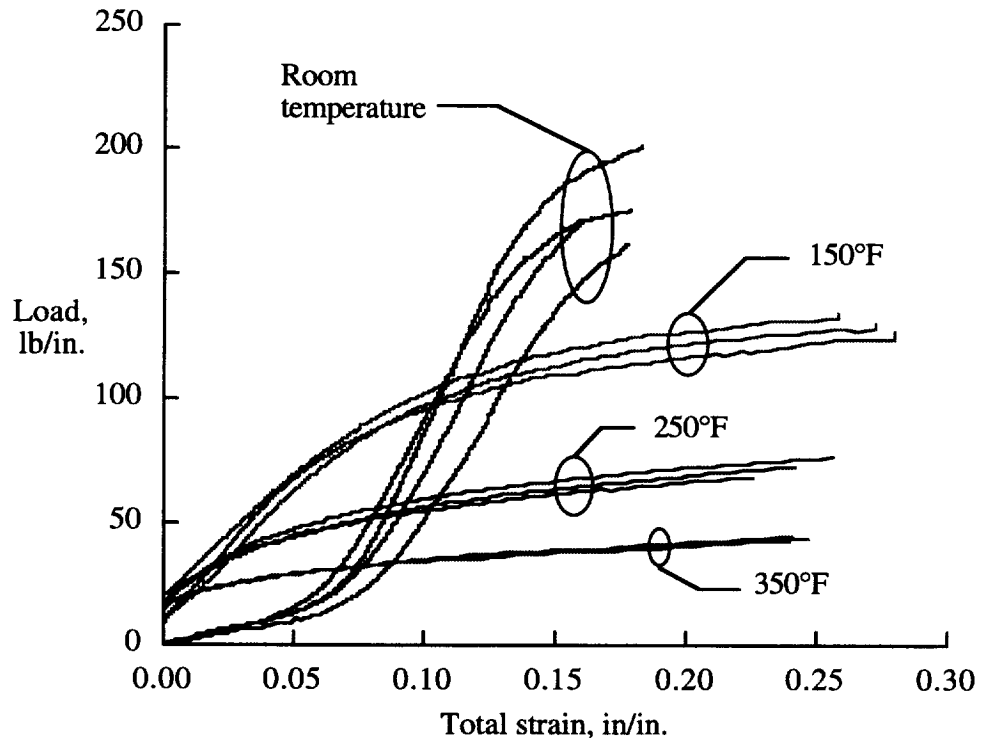

Figure 11: Effect of temperature on the load versus strain for 1-in-wide samples loaded in the gray thread direction with a load rate of 20 lb/min/in.

Figure 11 shows the effect of temperature of the strength of the material, as shown by plotting load versus strain. The specimens for the static testing were 1-in. wide and were loaded in the gray thread direction. In each case, the specimen test length was 4 in. The load rate was 20 lb/min/in. until failure. For all of the heated specimens, the test machine stroke limit was reached prior to failure. As expected, the maximum load decreased with temperature. The ambient temperature data are similar to data shown in previous figures. The ambient temperature specimens did not have a pre-load from which displacement measurements are referenced, and thus appear to initially have a large strain with only a small load. The elevated temperature specimens had a pre-load of 10 lb (150°F) and 15 lb (250°F and 350°F).

Creep testing was also performed at elevated temperature, and the results are shown in Figure 12. The specimens were 1.5-in. wide and were loaded in the gray thread direction at an initial load rate of 100 lb/min/in. up to the test load. The fact that the test loads chosen decreased with temperature implies the effect of temperature is even more than it appeared in the figure. Thus, if the 250°F and 350°F tests were performed at 77 lb/in, the time to failure would be even less. The tests at 350°F were performed at two different loads, 48 lb/in. and 40 lb/in. However, the different loads does not appear to be

significant as the 48 lb/in. lies between two 40 lb/in. tests. A photograph of a specimen after creep testing is shown in Figure 13. The necking down of the specimen is shown quite well with this specimen. However, most of the specimens did not fail in the manner shown in Figure 13.

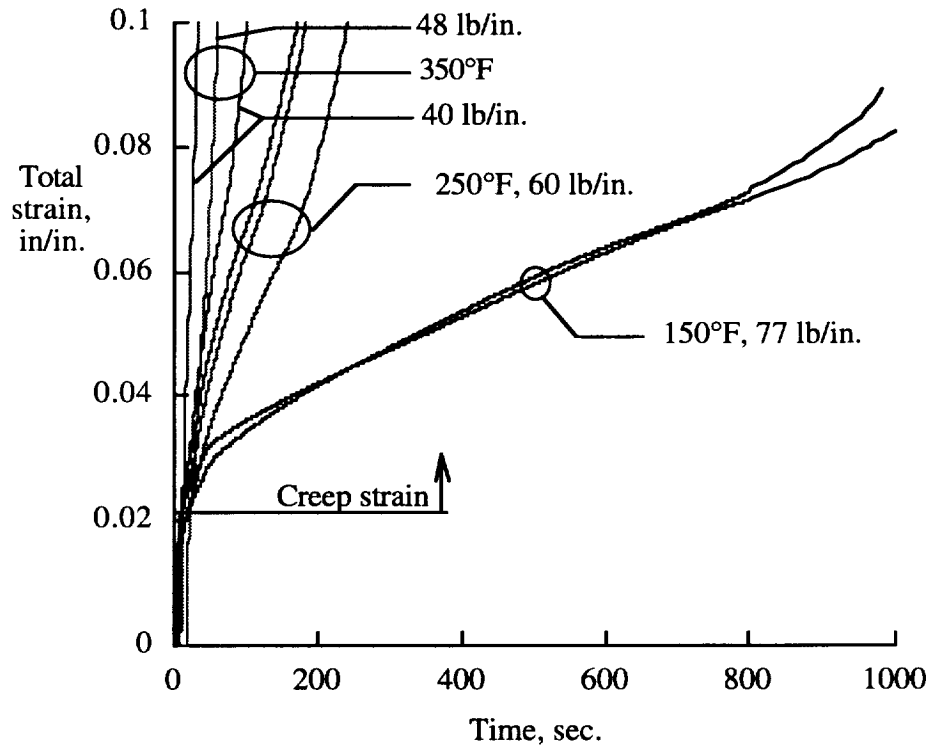

Figure 12: Effect of temperature on creep for 1.5-in-wide samples loaded in the gray thread direction with an initial load rate of 100 lb/min/in. up to the test load specified.

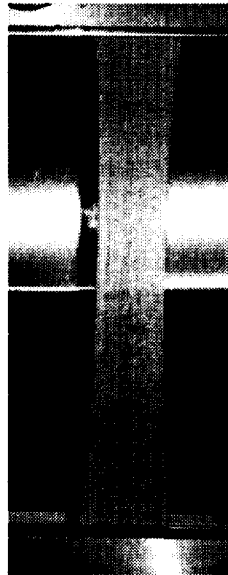

Figure 13: Photograph of seal failure after creep testing at elevated temperature.

Pressure Test of C-Seal

Two different C-seal designs were evaluated for use on the pressure box, both using the same material. The first was designed and fabricated by W. L. Gore & Associates. The Gore seal folded the corner over multiple times so that the planform of the entire seal remained a rectangle. However, the seal thickness in the corner consisted of multiple layers of fabric. A second seal was fabricated at NASA Langley Research Center by forming a length of the seal material into a C-shape and sewing the corners, with the corners being pleated. In this case, the seal thickness in the corner was a maximum of three layers. In both cases, there was at least one seam in the material away from a corner where the two ends of the length of fabric were sewn together.

A fixture was fabricated to test the C-seals at ambient temperature to failure. The fixture was designed to withstand an internal pressure of 200 psi over an area 13.5 in. x 13.5 in. The 200 psi was chosen to give enough margin so that the pressure could be increased to a level to fail the seals. A photograph of the test fixture is shown in Figure 14. The seal, pressurized to 6.1 psi, can be seen between the two 0.5-in-thick steel plates in the photograph.

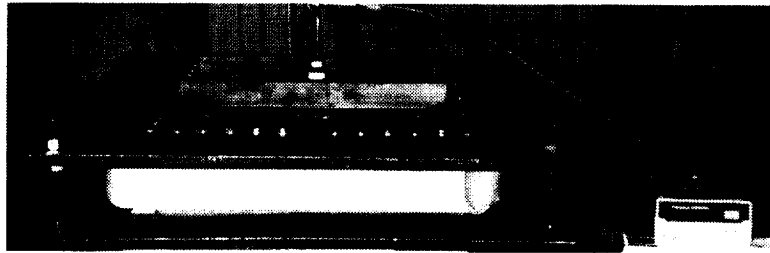

Figure 14: Photograph of the modified fixture for pressure testing the seals to 200 psi.

Gore-tex[®] gasket tape was used in several locations between the seal and the fixture for sealing purposes. W. L. Gore & Associates stated that a minimum of 2500 psi should be applied to the gasket tape to seal it, and that the material can take up to 22,000 psi. For the cryogenic-pressure-box application, once the seal is installed and the transition channel is bolted to the pressure box, access to the bolts holding down the seal will not be possible. In order to prevent problems associated with the gasket tape relaxing, and the bolts thus loosening, at least 3000 psi should be applied, and the bolts re-tightened a day later. Per W. L. Gore & Associates, re-tightening of the bolts will remove any slack from relaxation, and the gasket tape should not significantly relax further.

Gore Seal #1: The first seal tested was provided by W. L. Gore & Associates. The corners of the seal were folded multiple times and sewn together to form a pleated corner, as shown in Figure 15. Also shown in Figure 15 is the Gore-tex[®] gasket tape with adhesive backing placed on the outside surfaces of the seal over the bolts holes. On the inside surface of the seal can be seen a strip of seam seal material to reduce leaks at the seam. The bearing bar can also be seen in the photograph. When the C-seal was placed in the fixture, all the bolts were tightened with a torque wrench to 60 in-lb. The seal was then pressurized to 6.1 psi and examined for leaks with a soapy solution for detecting leaks. Small leaks were observed in the corners of the seal where there was a step change in the seal thickness from approximately 6 layers to one layer. The pressure was then gradually increased to 60 psi. The time to 60 psi was approximately 18 minutes. At 60 psi, a large leak was present and 400 psi was required from the high pressure nitrogen bottle to maintain 60 psi in the seal. The 60 psi pressure was maintained for only a few

seconds and the nitrogen supply was shut down. Upon examining the seal, it was observed that the seal material had been forced out of one of the corners at the step change between the multiple layers of the corner and the single layer of seal. The seal material that was forced out had a portion of a bolt hole through the edge of the fold. Thus when it was forced out (and tried to inflate) a 0.3-in-diameter hole was present in the seal. The data implied that this occurred at approximately 48 psi. It was also observed that the seal material had several pinhole leaks. In addition, the bolts on top of the plate leaked much more than the bolts on the bottom plate.

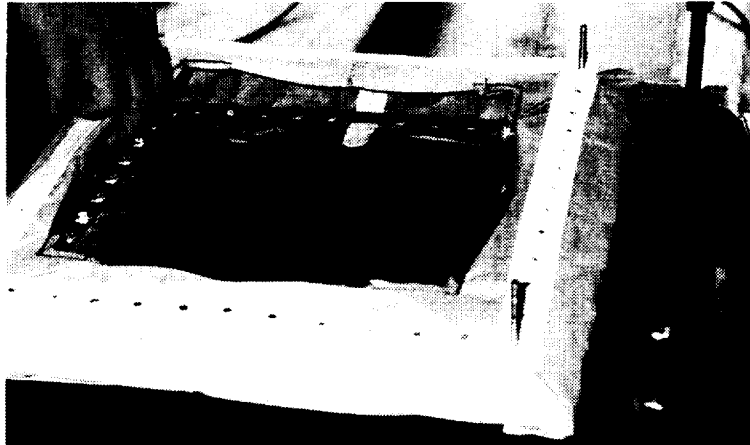

Figure 15: Photograph of Gore seal #1 prior to final assembly in fixture.

An attempt was made to patch the hole in the corner. A small piece of the seal material ($\sim 1 \text{ in}^2$) was bonded on both the inside and outside surfaces with EA 9394. After bonding, the patches were stitched together to reinforce the area, and another patch was bonded on the inside to seal the holes from the stitching. Prior to reassembly in the test fixture, the folds in the corner were etched with tetraetch and bonded together on the inside of the line of bolts. The bonding was performed in an attempt to reduce the leak path in the corners between the folds. The seal was pressurized to 21 psi and the applied pressure from the high pressure nitrogen bottle was 90 psi. The seal was pressurized up to 40 psi where the applied pressure was 141 psi. The Gore seam seal appeared to be sealing well. The seal was then taken to 60 psi. At 60 psi, the applied pressure was 300 psi, and a large leak occurred. The pressure quickly dropped, and at 40 psi, the applied pressure was still 300 psi and the pressure was then turned off and the seal was inspected. Upon examination at 2 psi, it was also noticed that there were a large number of leaks at the equator of the seal where the seal was folded when not pressurized. No leakage was apparent at the patched area.

Several lessons were learned from the tests with Gore seal #1. Pinhole leaks develop at the equator (where the seal was folded) of the seal. It appeared that the leaks may have been due to creasing and handling of the seal. The Gore seam sealing worked quite well, as no leakage was observed through the seam. However, sealing in the corners due to change in thickness of the fabric was a problem. A technique to patch holes in the seal appeared to be successful. Finally, bonding the corners together on the outside to reduce leakage was not successful.

LaRC Seal #1: A seal was next tested with pleated corners that was designed and fabricated at NASA LaRC. The seams on the first LaRC seal were sealed by bonding a strip of the radome material over the seams. The seal was then assembled in the test fixture with the bolts tightened to 100 in-lb and was then pressurized to 2 psi to check for

leaks. A small pinhole leak was found in one of the corners, but no major leaks were observed. The pressure was gradually increased to approximately 45 psi where a sudden leak occurred. The applied pressure from the nitrogen bottle increased to approximately 100 psi to maintain 40 psi in the seal. The pressure in the seal was gradually increased to 60 psi where it was held for 5 minutes. The applied pressure was 270 psi. An evaluation of the seal at 2 psi revealed that the biggest leaks were at the seams. Upon disassembly of the seal, it was observed that the patch over the seams had come unbonded from the seal. This appeared to be the cause for the sudden increase in required pressure around 45 psi. It appeared that the seal stretched, but the adhesive and patch did not.

An attempt was made to re-seal the seams. Two different techniques were tried. The first involved bonding Gore-tex[®] gasket tape between the seal and a patch of the radome material. At the other seam, a seal material patch was bonded to the seal with the patch only bonded on the outer edges and the sides of the patch bonded in the non-seamed region. The seal was then assembled back in the fixture using the same Gore-tex[®] gasket tape from the first test and pressurized to 2 psi. More pinholes were observed and excessive leakage was observed between the seal and the steel plates. It was determined that the Gore-tex[®] gasket tape should be replaced prior to each test. The seal was disassembled, new Gore-tex[®] gasket tape was put on the seal, and the seal was re-assembled into the fixture.

After new Gore-tex[®] gasket tape was placed between the seal and the steel plates, the seal was pressurized to 2 psi and observed. Numerous pinhole leaks were seen in the C-seal. The seal was gradually pressurized to 60 psi over the course of 18 minutes. At a seal pressure of 25 psi, the applied pressure was 50 psi. When the seal first reached 60 psi, the applied pressure was 330 psi. After about two minutes, the applied pressure required to maintain the 60 psi was 400 psi. At this time, the bottle pressure was down to 400 psi, so the pressure was cut back to 2 psi and the seal was visually inspected. Upon inspection at 2 psi, it was determined that the seam seal where the seal material was bonded in a picture frame pattern around the seams leaked less than the case where the Gore-tex[®] gasket tape was sandwiched between the radome material and the seal.

The seal was then modified so that both seams were sealed with the radome material bonded in a picture frame pattern. The bolts holding the seal in place were tightened to 200 in-lb the afternoon prior to testing. On the next morning, the Gore-tex[®] had relaxed and the torque was down to 100 in-lb. The bolts were all re-tightened to 200 in-lb and the seal was tested. An applied pressure of 60 psi was required to maintain a seal pressure of 20 psi. At a seal pressure of 38 psi, with the applied pressure at 160 psi, the bond on the seam seal gave way and the pressure suddenly dropped. The pressure was cut back to maintain 2 psi in the seal and the seal was inspected. Unlike previous cases, no leaks were observed through the bolts holes on the top or bottom. The seal was then left in the fixture overnight. Upon checking the torque on the bolts the next morning, the torque had dropped down to between 70-100 in-lb.

Several lessons were learned from the tests with LaRC seal #1. It appeared that the LaRC corner seal design was superior to the Gore corner seal design. The seal again developed leaks due to folding and handling. All of the seam sealing techniques tried leaked unacceptably, leaving the Gore seal seam tape as the only acceptable technique tested. The Gore-tex[®] gasket tape relaxed under load even after the second day implying it is not satisfactory for a closed system where the bolts cannot be re-tightened. On the positive side, even though the seal failed, it was determined that the seal material could withstand 60 psi.

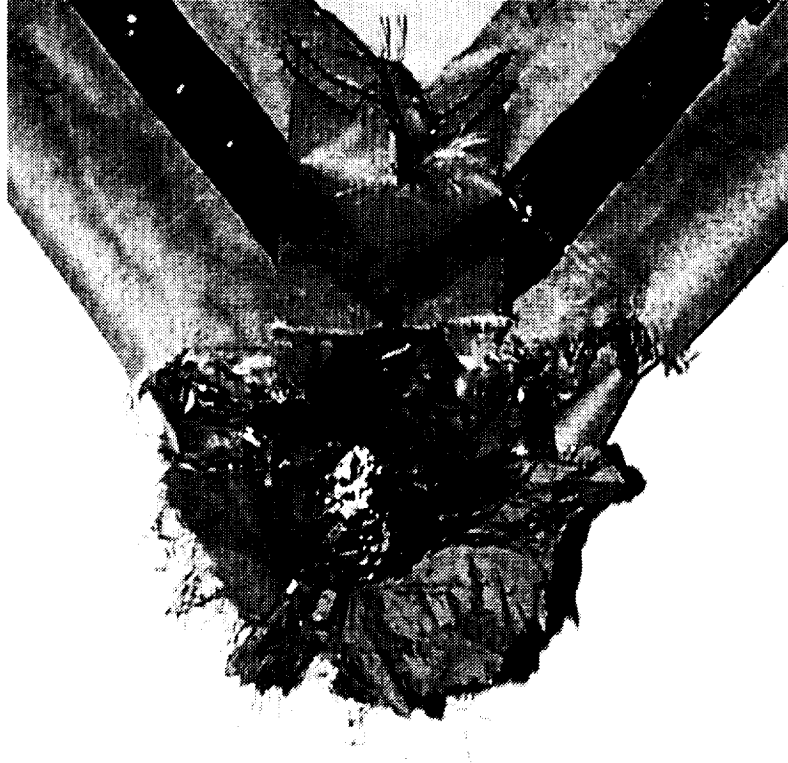

Figure 16: Photograph of the failed corner of LaRC Seal #2.

LaRC Seal #2: A second LaRC seal was fabricated exactly like the first LaRC seal. Grafoil[®] was used between the seal and the fixture instead of the Gore-tex[®] gasket tape in an effort to avoid the relaxation observed with the Gore-tex[®] gasket tape. In addition, an aluminized mylar liner was used on the inside in an attempt to reduce gas leakage through the seal. No attempt was made to seal the seam. Bolts were torqued to 130 in-lb. During an initial observation at several psi, leakage occurred between the seal and the plates at the location of the seams, but the seams did not leak. The seal was pressurized to 20 psi, and only 30 psi was required from the nitrogen bottle. The seal pressure was gradually increased to 60 psi over a period of 5 minutes and held for approximately 30 minutes. At 60 psi, the applied pressure was 70 psi. The Grafoil[®] seemed to do a better job of sealing than the Gore-tex[®] gasket tape. In prior tests, the Gore-tex[®] would be forced out of corners at the higher pressures causing excessive leakage. That kind of failure was not noticed with the Grafoil[®]. After approximately 29 minutes, the seal failed. A photograph of the failed portion of the seal is shown in Figure 16. The failure was symmetric about the top corner. Upon examining other corners, it was noticed that the corner of the inside bearing bar was beginning to tear the corner of the seal. It was determined that modifications to the bearing bar were required. The bearing bars were modified by cutting off the corners and radiusing the edges that were cut. Cutting off the corners eliminated the corner bolt hole.

LaRC Seal #3: A third LaRC seal was fabricated exactly like the first two LaRC seals. Grafoil[®] was again used between the seal and the fixture. However, 1-in-wide strips of adhesive backed Grafoil[®] were used instead of the non-adhesive Grafoil[®]. The bearing bars were machined as discussed above. Aluminized mylar was placed on the inside. Six bolts were omitted on the top due to the bolt holes either lying over the seam or over the edge of the fabric in a corner. The seal was pressurized to approximately 38 psi over a time of 10 minutes. At 38 psi, with an applied pressure of 70 psi, there was a

sudden increase in the regulator pressure, indicating that a leak had occurred. The pressure was increased to 48 psi with an applied pressure of 182 psi. Here, increased leakage again occur. The pressure was then increased to 60 psi (with a regulator pressure of 260 psi), held for 5 minutes, and then reduced. After removing the seal from the fixture, significant tear out of the bolt holes was noticed, in some cases, up to 1.5 in. It was suspected that the adhesive backed Grafoil[®] allowed the seal to slide and caused the tear out in the bolt holes.

LaRC Seal #4: A fourth LaRC seal was fabricated exactly like the prior LaRC seals. The same bearing bars that were previously rounded off on the corners were used along with non-adhesive Grafoil[®]. The seal pressure was taken to 60 psi and held for 11 minutes, upon which a seal failure occurred. The seal failed in the same corner as LaRC seal #2. Though it is uncertain, it was anticipated that the seal failure was due to loads in the corner portion of the seal. If the radius of the seal in some portion of the corner was greater than 1.5 in., which was the radius of the seal in the straight length between corners, the stress would be greater than the anticipated stress in the straight sections and could cause failure.

LaRC Seal #5: A fifth LaRC seal was fabricated exactly like the prior LaRC seals. The same bearing bars that were previously rounded off on the corners were used along with the non-adhesive Grafoil[®]. The aluminized mylar was again used on the inside as an impermeable liner. The seal was installed in the small cryogenic test box, shown in Figure 17, to facilitate cryogenic testing if the ambient temperature cycling was successful. The small cryogenic pressure box was fabricated by AET for development of the seals and to assist in the full size cryogenic pressure box design.

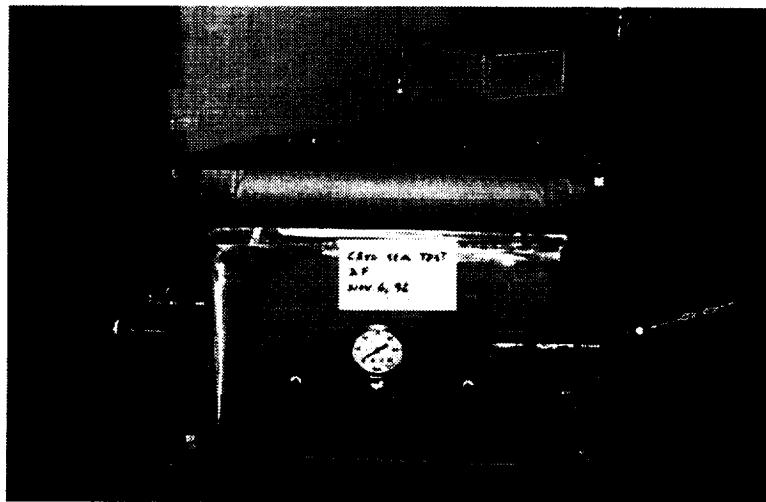

Figure 17: Photograph of the small cryogenic test box with LaRC Seal #5 ready for pressure testing.

A schematic diagram of the pressurization and cooling systems used for the small cryogenic pressure box is shown in Figure 18. The schematic diagram shows a fan penetrating the top plate and a LN2 bath on the top plate. The fan was initially used without the LN2 bath, but was determined to be a source of leaks and to not cool effectively. The LN2 bath was added and used to supplement cooling the seal. The pressurization gas was supplied from a high pressure nitrogen or helium bottle. The pressurization gas was precooled in a LN2 bath prior to pressurizing the box. A solenoid valve and burst disk were utilized on the box to facilitate releasing pressure in the box. In

addition to the LN2 bath on the top plate, cooling was provided by LN2 or LHe in the heat exchanger in the box. The liquid coolant was provided by a dewar. The coolant lines were purged with gaseous helium (GHe) or gaseous nitrogen (GN2) (same gas as used for cooling) prior to flowing the liquid to prevent condensing and freezing air.

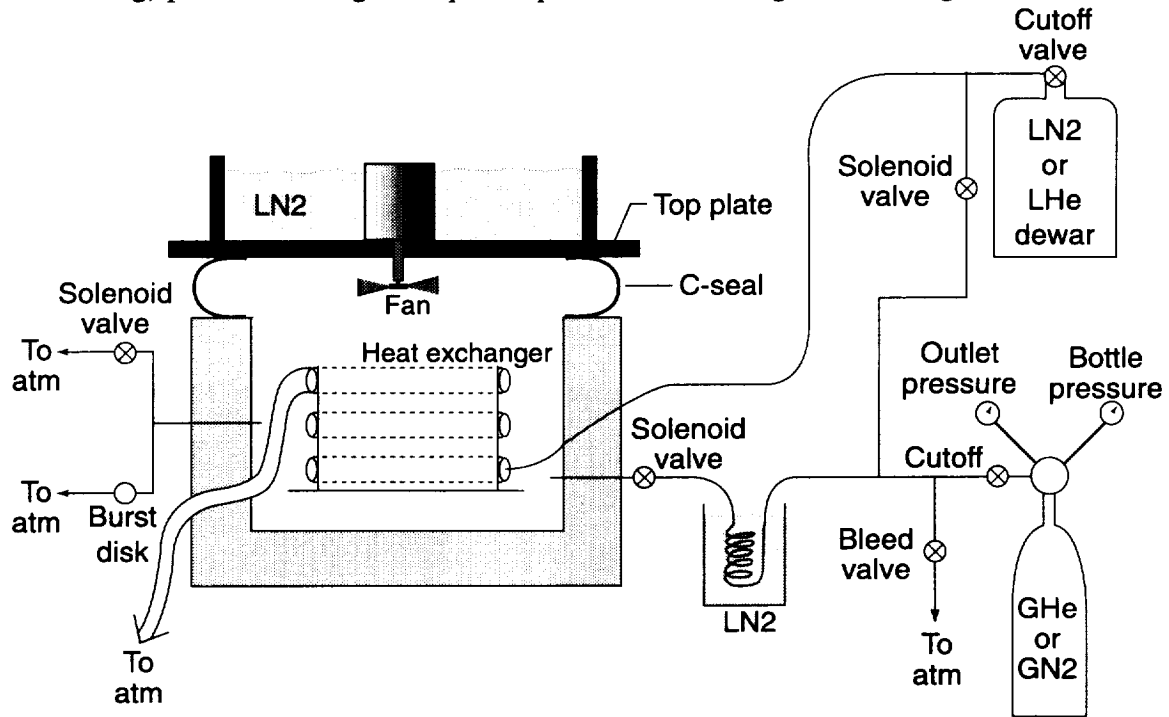

Figure 18: Schematic diagram of pressurization and cooling lines for the small cryogenic pressure box.

The internal pressure was taken to 35 psi rather than the 60 psi of previous tests. The purpose of only testing to 35 psi was an attempt to qualify a seal that could be used for system check out at 35 psi while the existing seal was modified to withstand extended use at 60 psi. A photograph of one corner of the seal is shown in Figure 19a prior to full pressurization. The folds in the corner are seen to still be “tucked in”. Figure 19b is a photograph of a corner after the seal had been fully pressurized, showing how the “tucked in” corner “puffs out” upon pressurization. The seal was taken to 35 psi and held for 30 minutes six times. No damage to the seal was evident after the six ambient temperature cycles at 35 psi.

The six tests on LaRC seal #5 were performed over a span of 6 days. After test #5, several bolts through the top plate were broken due to the deflection of the top plate at 35 psi. All but one of these bolts (a bolt that was broken below the surface of the plate) were replaced. The applied pressure seemed to experience a downward trend with increased number of cycles, as shown in Figure 20. Tests #1-5 were all performed the first two days. Test #6 was performed on the sixth day, and after the bolts were replaced. It appeared that the Grafoil[®] set with increased number of cycles, thus decreasing the required regulator pressure.

After the ambient temperature tests, the test fixture was prepared for testing at cryogenic temperatures. Due to excessive leakage during initial pressure testing, the fan was removed from the cryogenic fixture for the ambient temperature tests. Attempts were made to test at cryogenic temperatures without the fan, but cryogenic temperatures were not obtained. A magnetically coupled fan was then used that was inserted through

the top plate. An internal gas (N₂) temperature of -135°F was obtained, at which a leak in the LN₂ supply line was observed. The system was shut down, the leak was repaired, and the test restarted. A gas pressure of 1 psig was maintained during cooldown to -200°F. A plot of the internal gas temperature versus time during cooldown is shown by the squares in Figure 21. Since the internal gas temperature appeared to level off at -200°F, the pressure was increased to 35 psi over a period of 17 minutes. The pressure was increased to 13 psi by dumping LN₂ into the box. The majority of the remaining pressurization was done with the high pressure GN₂. Due to the warm pressurization gas temperatures, the internal gas temperature continued to rise throughout the test. After 30 minutes at 35 psi, the internal gas temperature was -18°F. The required regulator pressure was 170 psi, which was much higher than required for the ambient temperature tests (shown in Figure 20). It was the high leakage, and thus the high gas turnover rate, that caused the gas temperature increases. During a system checkout after the system warmed up, it was determined that the pressurization gas was leaking back through the valve that allowed LN₂ to be dumped directly into the box.

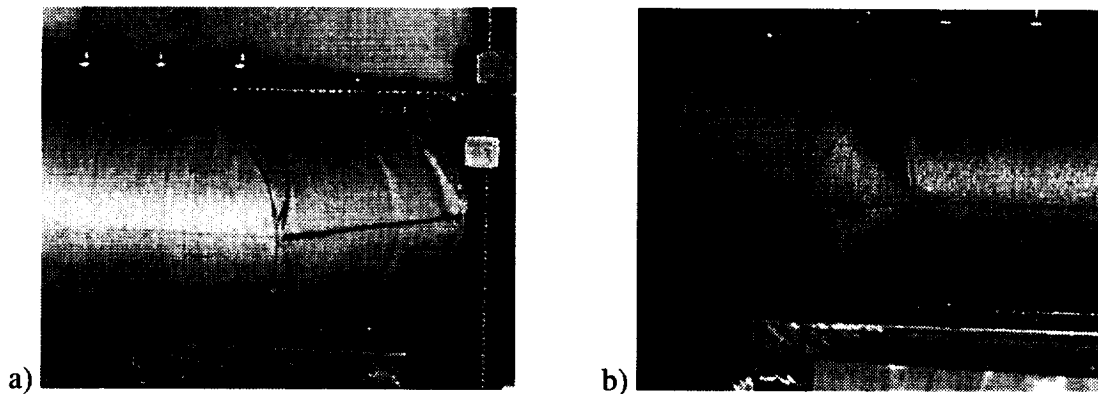

Figure 19: Photograph of the seal a) prior to full pressurization where initial folds can still be seen, and b) after pressurization, where prior folded regions are now “puffed” out.

Two modifications were made to the system before more tests were performed with LN₂ coolant. The valve that leaked the pressurization gas was shut off and the pressurization gas line was routed through a dewar of LN₂ prior to entry into the box. The box was then cooled down a second time, and a temperature of -260°F was attained. The temperature versus time during cooldown is shown by the circles in Figure 21. During this cooldown cycle, three pressurizations were performed. In all three, the regulator pressure was 50 psi, which compares very well with the values at ambient temperature discussed above. In all three tests, the initial gas temperature was approximately -260°F at the beginning of the pressurization. During the first 30 min cycle at 35 psi, the gas temperature in the box increased to -205°F, and during the second cycle to -221°F.

During the third cycle, the pressurization gas temperature rose to -238°F and then started decreasing again. After 25 min at 35 psi, the gas temperature was -249°F. At that time, the regulator pressure increased to 210 psi, but the box pressure only decreased to 29 psi. At the 28 min mark, the regulator dropped back to 50 psi and the internal box pressure rose to 35 psi. The applied pressure then again rose, this time to 150 psi, and then fell to 55 psi. The 30 min cycle was completed prior to shut down of the system. The cause of the changes in the applied pressure was believed to be due to condensation of the pressurization gas. The pressurization gas supply line was routed through LN₂ prior to entering the box. Over time, the supply lines became iced up, and thus insulated.

At 35 psi, the saturation temperature for LN2 is $\sim -298^{\circ}\text{F}$. The LN2 cooling the supply line was at atmospheric pressure, and thus $\sim -320^{\circ}\text{F}$. It appeared that the GN2 was cooled below -298°F , causing the high pressure gas to condense. With a drop in pressure, more pressurization gas was required and the saturation temperature dropped. Thus, cycling between high and low applied pressures occurred.

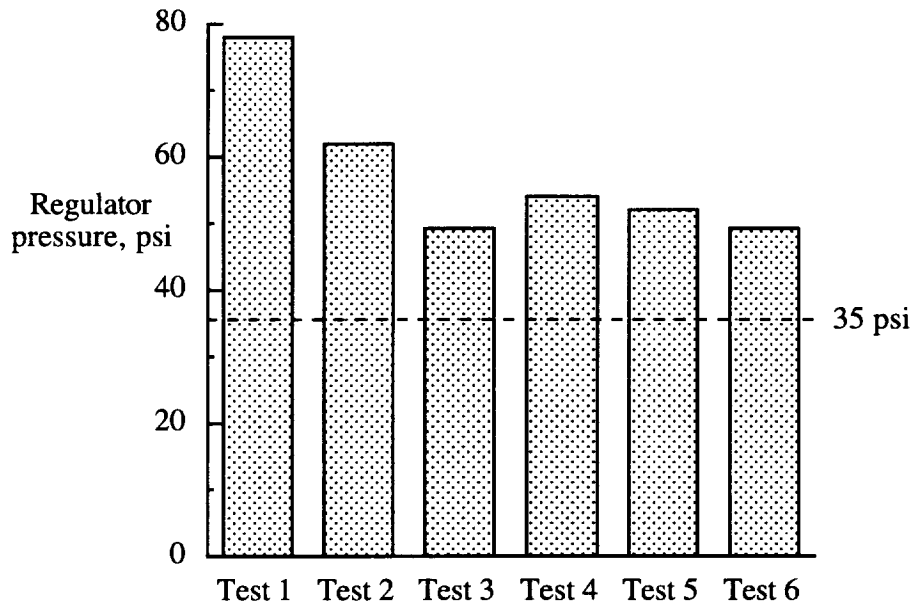

Figure 20: Regulator pressure for LaRC seal #5 ambient temperature tests when internal pressure was 35 psi.

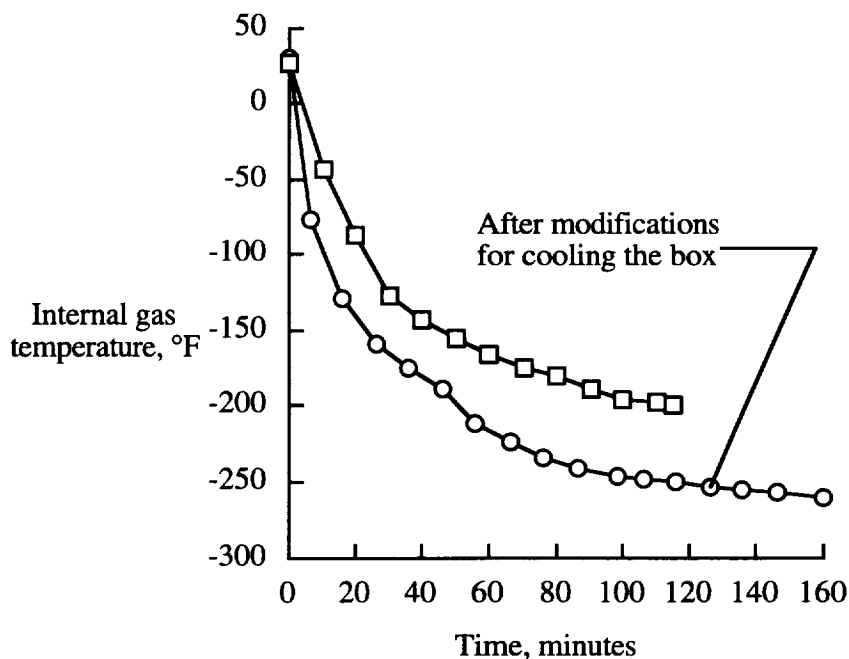

Figure 21: Internal gas temperature as a function of time during cooldown of LaRC seal #5 and test fixture.

After the cold tests with LN₂, the box was pressurized to 35 psi with GN₂ to recheck the applied pressure at ambient temperature. The applied pressure was 46 psi. The box, approximately 1 ft³ in volume, was then purged 8 times with GHe and pressurized to 35 psi with GHe. The applied pressure was 45 psi, indicating an acceptable leakage rate.

LaRC Seal #6: A sixth LaRC seal was fabricated to try to survive 60 psi. The high pressure seal was similar to the prior LaRC seals except the corners were reinforced. In two adjacent corners, an extra thickness of seal material was sewn onto the outside of the seal prior to folding and sewing the corners. The other two corners were sewn as in prior seals (one layer thick), and covered with a reinforcing pocket after fabrication. The design with the material sewn on prior to folding the corners results in a double thickness corner material. The design with the pocket over the corner results in two different shapes in the corner region, thus not a reinforced corner. The pocket will not allow the seal to bulge out as much as it would otherwise, thus limiting the radius of the seal in the corner. Since the load in the material is a function of the radius, limiting the radius can help the seal to survive higher pressures.

After installation in the ambient temperature test fixture, the seal was pressurized to 2 psi and checked for leaks. A leak could be heard in one of the corners. The internal pressure was then increased to 50 psi over a time of approximately 6 min. At 50 psi, the applied pressure was 65 psi. The 15 psi differential between the applied pressure and the internal pressure was consistent with other tests on the small cryogenic box. Keeping the pressure loss at 15 psi was significant since the high pressure seal was thicker in the corners, resulting in a larger thickness difference between the corners and the non-corner regions. The seal was pressurized a total of three times at 50 psi and held there for 30 min. each time. A visual examination of the seal after the three tests revealed no degradation of the seal.

The seal was then pressurized to 60 psi with nitrogen and held for 30 minutes. This was repeated for a total of five cycles. The applied pressure ranged from 75 to 85 psi. After the fifth cycle, the seal was removed from the test fixture and visually examined. Both of the corner concepts appeared in good shape, with no degradation visible. From these tests, it was concluded that either corner seal design would satisfy the load requirements. Since both corners seemed to satisfy the pressure load requirements, a decision on which corner to use was made based on assembly and sealing characteristics. The pocket corner appeared to be easier to seal during assembly and had less leakage during testing. Thus subsequent seals were made with the pocket corner. Three of the bolt holes in the seal were torn due to fixturing problems: the thread in the holes in the fixture had backed out and tore the seal. Due to the torn holes, this seal was not reused.

LaRC Seal #7: A seventh seal was fabricated with pocket reinforcements on all four corners. An attempt was made to position the corner folds on the seal such that the bolt holes would not penetrate a crease in the fold. As a result of this, the fabric was buckled in a few extra places in the corners. The seal was mounted in the small cryogenic box and initially pressure tested to 60 psi with GHe. The box was purged of air by pressurizing the box to 8 psi and releasing the pressure a total of 17 times. The box was then pressurized to 60 psi and held for 30 minutes. During this time, the regulator pressure was approximately 70 psi.

An attempt was next made to test the seal at cryogenic temperatures. The box was purged in the same manner as for the ambient temperature test. In addition, the coolant lines were also purged with GHe. Due to the difficulties with the magnetically coupled fan, the test was aborted after obtaining a helium gas temperature of -165°F. An attempt

was made to repair the fan prior to the next test. During the repair of the fan, it was noticed that the Rohacell foam bonded to the inside of the top plate was still attached. Since the top plate had yielded approximately 0.25 inches at the center of each side, it was encouraging that the foam remained bonded.

After the fan was repaired, cryogenic testing was begun again. The seal was leak tested to 20 psi. The applied pressure was 28 psi, indicating no major leaks existed. The box was purged with the GHe as before and then cooling with LN2 began. After approximately four hours, the internal gas temperature was -214°F and the top of the top plate temperature was -96°F . A switch was made to cool with LHe at that time. However, not enough LHe cooling could be provided. As a result, after one hour and with the internal gas temperature at -106°F and the top plate temperature at -75°F , the test was stopped.

Due to the large heat capacity of the stainless steel plate (3/8-in. thick), a large amount of time was required to cool the plate. Prior to the next test, a modification was made to cool the top plate by means other than internal convection. A trough was fabricated on top of the plate to contain LN2. The trough was lined with aluminized mylar to contain the LN2, as shown in Figure 22. The figure also shows the fan motor on top and the frosted seal under the top plate. By maintaining LN2 in contact with the plate, the plate could be cooled much quicker and the cold gas in the box could cool the remaining components.



Figure 22: Photograph of the LN2 trough on top of the top plate.

During the next test, the LN2 trough was filled with LN2 when the LN2 began to flow through the fan heat exchanger in the box. It took approximately 1:40 to cool the gas to a temperature of -270°F and the top plate to a temperature of -296°F . The system was then switched over to flow LHe through the fan heat exchanger after purging the lines with GHe. The internal gas temperature rose to about -155°F , and then slowly began to drop. It was determined that due to the long transfer line lengths and a frosted LHe transfer line (indicating a non-vacuum jacketed line), LHe temperature could not be reached. The system was then switched back to LN2, and within 45 minutes steady state temperatures of -275°F and -295°F were obtained for the gas and the top plate, respectively. The GHe pressure was then increased, but could not be raised very high without high applied pressures, i.e. 4 psi box pressure with 100 psi regulator pressure. A large column of cold gas could be seen exiting the box at the location of the fan, indicating leakage through the fan penetration. The system was shut down and allowed to warm.

Several modifications were made to the fixture prior to the next test. A heater was wrapped around the fan motor to keep it from frosting, all the fan mounting attachments were tightened, and the LHe transfer line length was reduced. The box was then pressurized to 20 psi, with only a 10 psi differential between the box and the regulator pressure, after which it was cooled down again. With a pressurization gas temperature of -213°F, the box pressure was 20 psi and the regulator pressure was 31 psi. At a box pressure of 30 psi, the regulator pressure was 45 psi. As the box pressure was increased, the pressure differential between the box pressure and the regulator pressure increased. A box pressure of 55 psi was obtained with an applied pressure of 120 psi, but could not be maintained. Again, cold gas seemed to be exiting the box at the location of the fan. The system was then turned off and allowed to warm. After making minor modifications to potential leak paths, the pressure in the box was increased at ambient temperature. At 54 psi box pressure, the applied pressure was 68 psi, indicating that no major leaks were present. However, the top plate was highly deformed, and the pressure in the box was quickly reduced without reaching 60 psi.

Four 3/8-in-thick stainless steel bars were welded to the top plate to stiffen the plate. The box pressure was then increased to 60 psi and held for 5 minutes. At 60 psi, the applied pressure was approximately 75 psi. The pressure was then reduced and the aluminized mylar was placed back on top of the plate, with the stainless steel stiffeners serving as the trough. The box was then pressurized to 60 psi and held for about 3 min before a bolt through the top plate holding the seal in place broke. The bolt could not be replaced without dismantling the plate and seal, so the bolt hole was drilled and tapped and a bolt was inserted in the hole to plug the hole. The pressure was then taken to 60 psi and all systems appeared satisfactory.

The box was then cooled down to LN2 temperatures, and the pressure was increased gradually. At a box pressure of 30 psi, the input was 45 psi. However, when the box pressure reached 48 psi, the input pressure was 78 psi, and the box pressure could no longer be maintained. The pressure was then cut off to the box. The box was allowed to warm up, and the seals around the fan were modified in an attempt to seal any leaks. The box was then pressurized to 60 psi at ambient temperature with a 71 psi input pressure. The box was again cooled to LN2 temperatures and then pressurized. At 15 psi, a large leak occurred and the pressure was cut back.

At this time it was decided to remove the fan from the top of the plate and plug the hole since the fan penetration was the location of the major leaks. After this was done, the box was cooled again with LN2. An internal temperature of -220 to -250°F was obtained. The box was then pressurized, and though a leak occurred, 50 psi was held for approximately 20 min, and 60 psi was held for approximately 5 min.

The seal was then tested for two 30 minute cycles at 60 psi. During the first 30-min. cycle, the internal temperature began at -220°F and was down to -242°F at the end of the 30 minutes. The applied pressure was 90 psi at the beginning of the 30 minutes at 60 psi internal pressure, but was down to 75 psi at the end of the cycle. During the second cycle, the internal gas temperature and pressure began at -236°F and 81 psi and ended at -239°F and 75 psi. At the end of the second cycle, the pressurization and cooling were ceased.

The final test on the seal was a burst test at ambient temperature. The seal was placed back in the high pressure, ambient temperature test fixture shown in Figure 14. The seal was pressurized at a rate of approximately 5 psi/min with nitrogen gas. The seal failed at an internal pressure of 103 psi, 16 minutes after starting the pressurization, with an applied pressure of 125 psi. From a post-test video examination of the seal failure, it

was noticed that the corner reinforcement opposite the corner that burst, failed just prior to the seal failure. Within seconds of the corner reinforcement failure (stitching pulling apart on the reinforcement), the seal failed at the opposite corner. From an examination of the burst region, it appeared that the failure originated at the edge of the corner reinforcement where it was sewn onto the seal. The torn region of the seal was centered about that stitching, as shown in Figure 23. The top plate deflected approximately 0.5 in. at the maximum pressure of 103 psi. The plate deflection increased the chordlength of the curved seal, and thus increased the radius of curvature of the seal. For the undeflected plate, with a plate separation distance and seal diameter of 3 in, the load on the seal material was 154 lb/in. at 103 psi. With a 0.5-in-plate deflection, the load on the seal material in the hoop direction was approximately 185 lb/in. Since the plate was deflected the greatest between the corners where it was held down, the center of each side was where the maximum loads were experienced in the seal.



Figure 23: Photograph of LaRC seal #7 after failure at 103 psi.

LaRC Seal #8: An eighth seal was fabricated solely for the purpose of burst testing. The seal was very similar to the prior seal except that the corner was folded a little tighter, i.e., not as wide a pleat, and the white thread direction of the seal material ran around the perimeter of the seal as it would in a full size seal. The seal was mounted in the ambient temperature, high pressure test fixture and was leak tested at 20 psi. The seal appeared to be sealing well.



Figure 24: Photograph of LaRC seal #8 after failure at 100.2 psi.

The seal was pressurized at a rate of 5 psi/min and burst at 100.2 psi. The burst pressure was very similar to the prior test where the seal was cycled from 0 to 60 psi

numerous times prior to bursting. As in the prior test, the top plate was deformed significantly during the test. The bottle pressure dropped during the test from an initial 2000 psi to ~1700 psi. Figure 24 shows a photograph of the seal after failure. On this seal, the torn seal was confined to the region between the corner reinforcements. It appeared that the failure may have originated at the center between the two corners. At this location, the seal radius was larger due to the plate deflection, resulting in larger loads in the seal.

Acknowledgments

The author would like to thank NASA Langley Research Center for funding this work under contract No. NAS1-96014. The author would like to thank Henry Wright of NASA Langley for his invaluable input during the testing of the seals. His advice was a key to the success of the program. The author would also like to thank Dave Shuster, Dick Winning, Cheri Wood, and George Cowley of NASA Langley for their work in testing the prototype seals. Their hard work is greatly appreciated. Finally, the author would like to thank AET of Woburn, MA for locating the Gore radome material and suggesting it as a seal material.

Concluding Remarks

Seals have been developed to contain 60 psi GHe for the NASA Langley cryogenic pressure box. The seals remain flexible at cryogenic temperatures and carry the pressure loads with minimal leakage. The seal material was tested at ambient temperature as well as at LN₂, LHe, and elevated temperature in both static and creep testing. In addition, a prototype seal was pressure tested in a small cryogenic box at 60 psi at cryogenic temperatures. The seal material leaked and thus required an aluminized mylar liner be used to reduce the pressurization gas leakage. Thin sheets of Grafoil[®] were used as a gasket material with great success. The Grafoil[®] did not relax over time, and thus did not result in leaks between the seal and the fixture after the initial torquing of the bolts. After numerous 30 min pressurization cycles at both ambient and cryogenic temperatures, the seal was burst tested twice and failed between 100 and 102 psi.

References

1. D. R. Ambur, J. S. Sikora, J. F. Maguire, and P. M. Winn, Development of a Pressure Box to Evaluate Reusable-Launch-Vehicle Cryogenic-Tank Panels, 37th Structures, Structural Dynamics, and Materials Conference, Salt Lake City, UT, April, 1996, AIAA-96-1640.
2. T. F. Johnson, R. Natividad, H. K. Rivers, and R. Smith, Thermal Structures Technology Development for Reusable Launch Vehicle Cryogenic Propellant Tanks, Space Technology and Application International Forum, Albuquerque, NM, January 1998.
3. D. E. Glass, J. Stevens, J. A. Cerro, R. F. Vause, and C. L. Blackburn, Development and Capability of the NASA Langley Cryogenic Pressure Box, AIAA 8th International Space Planes and Hypersonic Systems and Technologies Conference, AIAA 98-1507, Norfolk, VA, April 27-30, 1998.

REPORT DOCUMENTATION PAGE			Form Approved OMB No. 0704-0188
Public reporting burden for this collection of information is estimated to average 1 hour per response, including the time for reviewing instructions, searching existing data sources, gathering and maintaining the data needed, and completing and reviewing the collection of information. Send comments regarding this burden estimate or any other aspect of this collection of information, including suggestions for reducing this burden, to Washington Headquarters Services, Directorate for Information Operations and Reports, 1215 Jefferson Davis Highway, Suite 1204, Arlington, VA 22202-4302, and to the Office of Management and Budget, Paperwork Reduction Project (0704-0188), Washington, DC 20503.			
1. AGENCY USE ONLY (Leave blank)	2. REPORT DATE May 1998	3. REPORT TYPE AND DATES COVERED Contractor Report	
4. TITLE AND SUBTITLE Development of a Flexible Seal for a 60 psi Cryogenic Pressure Box		5. FUNDING NUMBERS NAS1-96014 G733056J35 WU 242-33-01-09	
6. AUTHOR(S) David E. Glass			
7. PERFORMING ORGANIZATION NAME(S) AND ADDRESS(ES) Analytical Services & Materials, Inc. 107 Research Drive Hampton, VA 23669-1340		8. PERFORMING ORGANIZATION REPORT NUMBER AS&M-LS05-98-02	
9. SPONSORING/MONITORING AGENCY NAME(S) AND ADDRESS(ES) National Aeronautics and Space Administration Langley Research Center Hampton, VA 23681-2199		10. SPONSORING/MONITORING AGENCY REPORT NUMBER NASA/CR-1998-207669	
11. SUPPLEMENTARY NOTES Langley Technical Monitor: Steven J. Scotti			
12a. DISTRIBUTION/AVAILABILITY STATEMENT Unclassified-Unlimited Subject Category 27 Distribution: Nonstandard Availability: NASA CASI (301) 621-0390		12b. DISTRIBUTION CODE	
13. ABSTRACT (Maximum 200 words) A cryogenic pressure box test facility has been designed and fabricated for use at NASA Langley Research Center (LaRC) to subject 5 ft x 6 ft curved panels to cryogenic temperatures and biaxial tensile loads. The cryogenic pressure box is capable of testing curved panels down to -423°F (20K) with 54 psig maximum pressure. The key challenge in the design and fabrication of the pressure box was the development of a seal that could remain flexible at -423°F and contain 60 psi gaseous helium as the pressurization gas. A C-shaped seal was developed using a Gore-tex woven fabric. Mechanical testing of the fabric at room and elevated temperature, liquid nitrogen temperature, and liquid helium temperature demonstrated the strength and creep resistance of the material over the desired operating range. A small scale cryogenic pressure box was used to test prototype seals at cryogenic temperatures up to 60 psi. Preliminary tests indicated that excessive leakage was present through the seal. As a result, an aluminized mylar liner was placed inside the Gore-tex seal to reduce leakage through the seal. The final seal configuration resulted in minimal pressure loss during seal testing.			
14. SUBJECT TERMS Cryogenic tanks, seals		15. NUMBER OF PAGES 31	16. PRICE CODE A03
17. SECURITY CLASSIFICATION OF REPORT Unclassified	18. SECURITY CLASSIFICATION OF THIS PAGE Unclassified	19. SECURITY CLASSIFICATION OF ABSTRACT Unclassified	20. LIMITATION OF ABSTRACT