

Reprinted from *J. Mol. Biol.* (1996) 262, 31-42

JMB



NA 72 5 281

REPRINT
20-11-012
RE-MAILED
578 925

Specialization of the DNA-cleaving Activity of a Group I Ribozyme Through *In Vitro* Evolution

Joyce Tsang and Gerald F. Joyce

Specialization of the DNA-cleaving Activity of a Group I Ribozyme Through *In Vitro* Evolution

Joyce Tsang and Gerald F. Joyce*

Departments of Chemistry
and Molecular Biology and
The Skaggs Institute for
Chemical Biology, The
Scripps Research Institute
10550 North Torrey Pines
Road, La Jolla, CA 92037
USA

In an earlier study, an *in vitro* evolution procedure was applied to a large population of variants of the *Tetrahymena* group I ribozyme to obtain individuals with a 10^5 -fold improved ability to cleave a target single-stranded DNA substrate under simulated physiological conditions. The evolved ribozymes also showed a twofold improvement, compared to the wild-type, in their ability to cleave a single-stranded RNA substrate. Here, we report continuation of the *in vitro* evolution process using a new selection strategy to achieve both enhanced DNA and diminished RNA-cleavage activity. Our strategy combines a positive selection for DNA cleavage with a negative selection against RNA binding. After 36 "generations" of *in vitro* evolution, the evolved population showed an ~ 100 -fold increase in the ratio of DNA to RNA-cleavage activity. Site-directed mutagenesis experiments confirmed the selective advantage of two covarying mutations within the catalytic core of the ribozyme that are largely responsible for this modified behavior. The population of ribozymes has now undergone a total of 63 successive generations of evolution, resulting in an average of 28 mutations relative to the wild-type that are responsible for the altered phenotype.

© 1996 Academic Press Limited

*Corresponding author

Keywords: catalytic RNA; DNA cleavage; *in vitro* evolution; ribozyme

Introduction

In vitro evolution has proven to be a powerful technique for obtaining novel catalytic RNAs (for reviews, see Breaker & Joyce, 1994; Lorsch & Szostak, 1996). One approach begins with a pool of variants of an existing ribozyme that catalyzes a reaction similar to the one desired. Repeated rounds of selection, amplification, and mutation are carried out until the desired catalyst is obtained. Previous examples of this approach have demonstrated that the original catalytic activity usually is retained and may even improve, suggesting that *in vitro* evolution has served to broaden rather than transform the activity of the starting enzyme. For example, a group I ribozyme that is active in the presence of Mg^{2+} but not Ca^{2+} was evolved to function in the presence of Ca^{2+} , but did not lose its ability to function in the presence of Mg^{2+} (Lehman & Joyce, 1993). More pertinent to the present

study, a group I ribozyme that efficiently cleaves RNA but has a barely detectable ability to cleave DNA was evolved to cleave DNA efficiently, yet showed a slight improvement in its ability to cleave RNA (Beaudry & Joyce, 1992; Tsang & Joyce, 1994). Here we describe a novel *in vitro* evolution scheme that simultaneously selects for the desired activity and against the existing one, leading to specialization rather than expansion of the enzyme's capabilities.

We began this study with variants of the self-splicing group I intron of *Tetrahymena thermophila*, a ribozyme that catalyzes the sequence-specific cleavage of a single-stranded RNA substrate *via* a phosphoester transfer mechanism (Figure 1; Zaug & Cech, 1986; Zaug *et al.*, 1986). The ribozyme binds its substrate in two steps: first, a region at the 5' end of the ribozyme, termed the "internal guide sequence" (IGS), forms Watson-Crick base-pairs with the substrate; then the ribozyme/substrate duplex (P1 helix) forms tertiary interactions with residues in the catalytic core of the ribozyme. This positions a specific phosphoester bond of the substrate in close proximity to the 3'-hydroxyl of a bound guanosine nucleoside, including the guanosine that lies at the 3' end of the

Abbreviations used: IGS, internal guide sequence; PCR, polymerase chain reaction; G_n , generation after n rounds of *in vitro* evolution; E, ribozyme; rP, RNA product; dS, DNA substrate; dP, DNA product; wt, wild-type; P1 helix, ribozyme/substrate duplex.

ribozyme (Herschlag, 1992; Bevilacqua *et al.*, 1992). A phosphoester transfer reaction ensues, involving nucleophilic attack by the guanosine 3'-OH,

and resulting in cleavage of the substrate with concomitant ligation of the 3' portion of the substrate to the 3' oxygen of guanosine (Michel

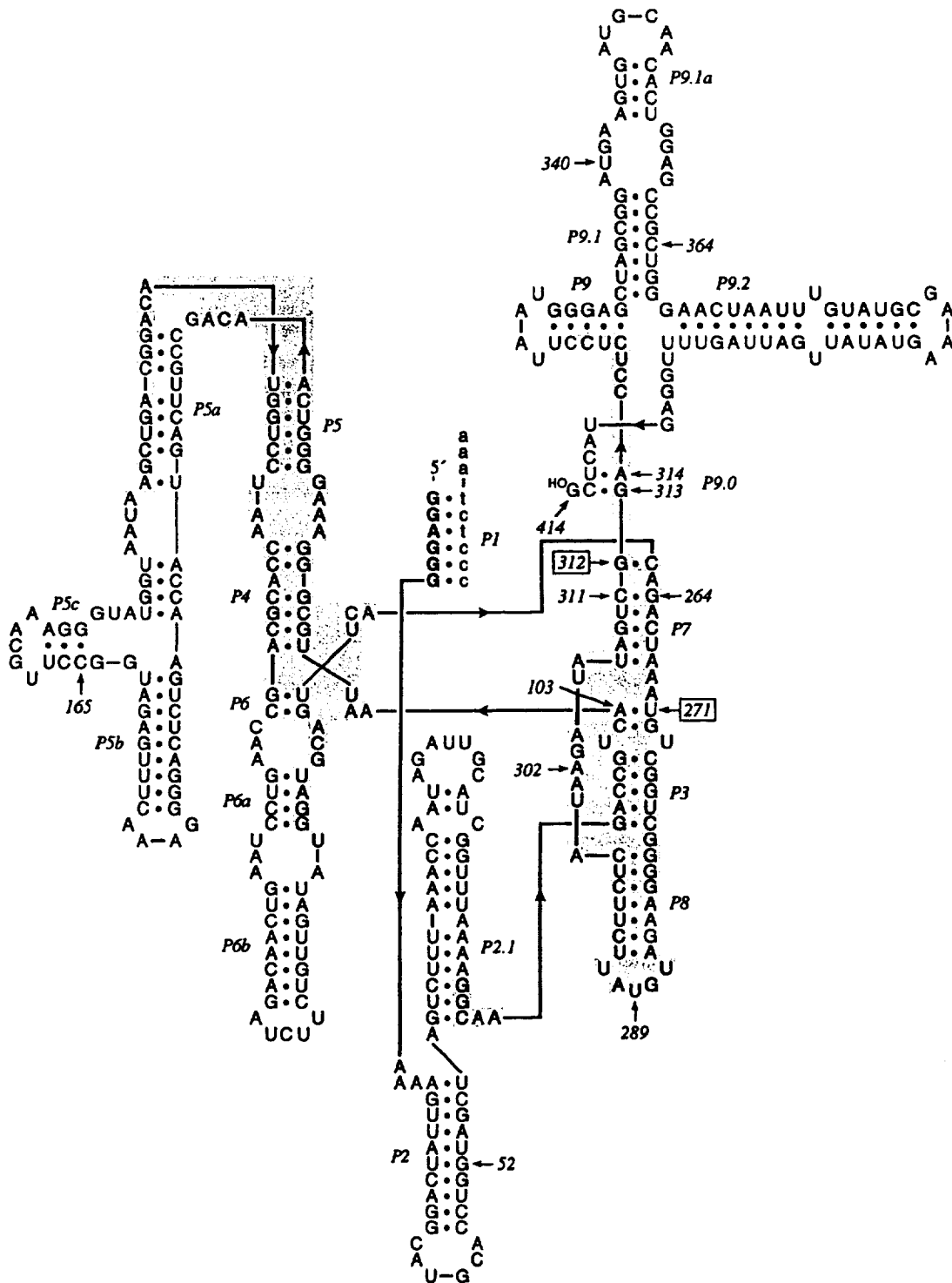

Figure 1. Secondary structure of the *Tetrahymena* ribozyme (Cech *et al.*, 1994). Paired structural elements are designated by P_i . Joining regions between paired elements i and j , referred to as j_i/j_j , are not labeled. Nucleotide positions that were partially randomized in the initial population are indicated by shaded regions. The internal guide sequence (IGS) is shown in bold face, and the DNA substrate is shown in lowercase letters. Nucleotide positions discussed in the text are labeled. Positions that were subjected to site-directed mutagenesis are boxed.

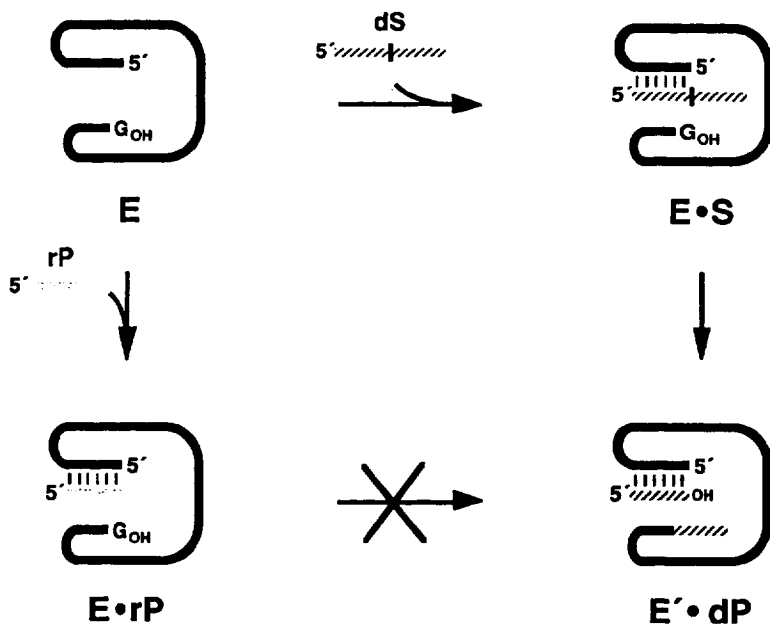

Figure 2. Selection strategy. The ribozyme population (E) was challenged to cleave the DNA substrate (dS) in the presence of an inhibitor corresponding to the 5' product portion of the RNA-cleavage reaction (rP). Ribozymes that cleaved the DNA substrate became attached to the 3' portion of the substrate, which served as a tag for subsequent selective amplification. Ribozymes that bound from RNA product were prevented from cleaving the DNA substrate and were not amplified.

et al., 1989; Been & Perotta, 1991; Mei & Herschlag, 1996).

Certain 2'-hydroxyl groups within the RNA substrate form tertiary contacts with residues in the catalytic core of the ribozyme during the second step of substrate binding (Pyle & Cech, 1991; Pyle *et al.*, 1992; Bevilacqua & Turner, 1991). In addition, the 2'-hydroxyl of the ribonucleotide at the cleavage site contributes $\sim 10^3$ -fold to transition-state stabilization during the transesterification reaction (Herschlag *et al.*, 1993). It is not surprising, therefore, that the wild-type ribozyme cleaves a DNA substrate very inefficiently, with a 10^3 -fold reduction in substrate binding affinity and a 10^3 -fold reduction in catalytic rate compared to the reaction with an analogous RNA substrate.

Beaudry & Joyce (1992) used an *in vitro* evolution procedure to improve the DNA-cleaving activity of the *Tetrahymena* ribozyme by about 100-fold under simulated physiological conditions. A pool of 10^{13} variants of the *Tetrahymena* ribozyme was generated, and individuals with superior DNA-cleaving activity were preferentially amplified on the basis of attachment of the 3' portion of the substrate to the 3' end of the ribozyme, which occurred as a consequence of the cleavage reaction. Amplified molecules were utilized as templates for cDNA synthesis, the resulting cDNA was amplified by a polymerase chain reaction (PCR), and the PCR products were transcribed to generate a new pool of RNAs. This procedure was carried out for nine successive generations, resulting in RNA molecules that cleaved a single-stranded DNA substrate with a k_{cat} of 0.06 min^{-1} and K_m of $2 \mu\text{M}$. This represents an improvement of 30-fold and threefold, respectively, compared to the wild-type *Tetrahymena* ribozyme.

In a subsequent *in vitro* evolution study, Tsang & Joyce (1994) set out to optimize both k_{cat} and K_m by appropriate manipulation of the selection constraints. First, the substrate concentration was reduced 50-fold during the target reaction to favor ribozymes with high substrate binding affinity. This resulted in a 25-fold improvement in both K_d and K_m over nine generations of *in vitro* evolution. Next, the time allowed for the cleavage reaction was decreased by 12-fold to favor ribozymes with a fast rate of reaction. This resulted in a 50-fold improvement in k_{cat} over nine generations, with no significant change in K_m . Thus, after a total of 27 generations of *in vitro* evolution, ribozymes were obtained that cleaved DNA with a catalytic efficiency, k_{cat}/K_m , of $3.2 \times 10^6 \text{ M}^{-1} \text{ min}^{-1}$, representing a $\sim 10^5$ -fold improvement compared to the wild-type. However, as noted above, RNA-cleavage activity also improved, so that ribozymes obtained after the 27th generation still cleaved RNA about tenfold more efficiently than they cleaved DNA. Thus, the *in vitro* evolution process had led to a broadening of the catalytic abilities of the ribozyme. Nature had evolved an RNA catalyst with the ability to cleave RNA; then, in the laboratory, this activity was generalized to include both RNA and DNA substrates.

In this study, we devised a novel *in vitro* evolution strategy in order to improve the specificity of the ribozyme for DNA compared to RNA substrates. Our scheme combined a positive selection for DNA cleavage with a negative selection against RNA binding. As shown in Figure 2, ribozymes were challenged to cleave a DNA substrate in the presence of a large excess of an RNA inhibitor that corresponds to the portion of an RNA substrate that forms base-pairs with the IGS. As in our previous selection procedure, ribozymes

that cleaved the DNA substrate became tagged by attachment of the 3' portion of the substrate to their 3' end, and thus were selectively converted to cDNA and amplified. On the other hand, ribozymes that preferentially bound the RNA inhibitor were prevented from binding and cleaving the DNA substrate, and thus could not be amplified.

Employing this selection scheme, we subjected the pool of ribozymes obtained after 27 generations of *in vitro* evolution to an additional 36 generations, selecting for DNA cleavage activity in the presence of progressively increasing amounts of the RNA inhibitor. Based on kinetic analysis of the resulting individuals, the population responded as expected. The ratio of DNA to RNA-cleavage activity improved about 100-fold, with about a 50-fold increase in k_{cat}/K_m for DNA cleavage and a slight decrease in k_{cat}/K_m for RNA cleavage, measured for the population as a whole. A characteristic individual isolated from the evolved population exhibited k_{cat}/K_m values of $1.6 \times 10^7 \text{ M}^{-1} \text{ min}^{-1}$ and $6.9 \times 10^6 \text{ M}^{-1} \text{ min}^{-1}$ for the DNA and RNA-cleavage reactions, respectively. This altered behavior, relative to the DNA-cleaving ribozymes obtained earlier, is largely due to two concerted mutations that arose within the catalytic core of the ribozyme over the course of the *in vitro* evolution process.

Results

Evolutionary Improvement in DNA substrate specificity

Beginning with the population of DNA-cleaving ribozymes obtained after 27 generations of *in vitro* evolution (Tsang & Joyce, 1994), we carried out 36 additional generations of the evolution process, applying a new selection strategy that simultaneously selected for cleavage of a DNA substrate and against binding of an RNA inhibitor (Figure 2). The RNA inhibitor, corresponding to the 5' product of the ribozyme-catalyzed RNA-cleavage reaction, bound tightly to the IGS of the ribozyme ($K_d < 1 \text{ nM}$; Tsang & Joyce, 1994), thus preventing binding of the DNA substrate. In this way, ribozymes that preferentially bound RNA over DNA were selectively disfavored. At the outset, the concentration of DNA substrate and RNA inhibitor was $0.2 \mu\text{M}$ and $0.1 \mu\text{M}$, respectively. The concentration of RNA inhibitor was increased gradually over the course of *in vitro* evolution to $2 \mu\text{M}$ in order to maintain strong selection pressure against RNA binding.

Selection against RNA binding also could have been accomplished using a full-length RNA substrate as the inhibitor. However, because the chemical step of RNA cleavage by the wild-type ribozyme is very fast and substrate binding is rate limiting (Herschlag & Cech, 1990), we felt that the same negative selection pressure could be exerted using either the RNA substrate or the 5' RNA product. Carrying out selection in the presence of

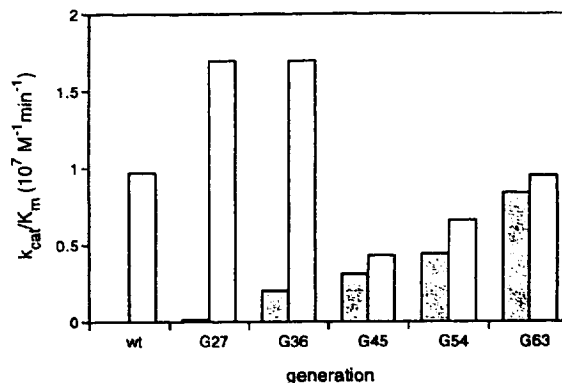

Figure 3. Change in the catalytic efficiency of DNA and RNA-cleavage reactions for the evolving population of ribozymes. The k_{cat}/K_m values for DNA cleavage (filled) and RNA cleavage (open) were determined under single-turnover conditions for the population as a whole, based on a least-squares fit to the equation: $k_{\text{obs}} = (k_{\text{cat}}/K_m)[E]$, where $[E] \ll K_m$ and k_{obs} is the initial rate of the reaction (see Materials and Methods). PCR mutagenesis was performed twice at G36 and three times at G45 and G54 to increase the diversity of the evolving population, as described in Materials and Methods.

the 5' RNA product provided additional negative pressure against ribozymes that catalyzed a ligation reaction resembling the reverse of the DNA-cleavage reaction, in which the 5' RNA product bound to a reacted DNA-cleaving ribozyme and attacked the ligation junction between the 3' end of the ribozyme and the 3' portion of the DNA substrate, thereby releasing the tag that identifies the ribozyme for selection.

In order to assess the impact of our selection strategy, we determined the catalytic efficiency of both DNA and RNA cleavage for the population of ribozymes obtained after the 27th, 36th, 45th, 54th, and 63rd generations of *in vitro* evolution (Figure 3). The preference for DNA over RNA, as determined by the relative k_{cat}/K_m values for the reaction with DNA versus RNA substrates, increased steadily, improving 100-fold between generations 27 and 63. There was an overall 50-fold increase in DNA-cleavage activity and a twofold decrease in RNA-cleavage activity. From generation 27 through 36, there was a modest improvement in DNA-cleavage activity, but no significant change in RNA-cleavage activity. Based on sequence analysis (see below), we concluded that the population at that point in the evolution process lacked sufficient diversity for the desired phenotype to emerge. Accordingly, we subjected the population at generation 36 to two successive rounds of mutagenic PCR, introducing random mutations at an expected frequency of 1.4% per nucleotide position (Cadwell & Joyce, 1992). Following this randomization procedure and an additional nine generations of *in vitro* evolution, RNA-cleavage activity declined significantly (Figure 3). Over the final 18 generations, from generations 45 through 63, both DNA and RNA-cleavage activity rose

Table 1. Catalytic properties and sugar-specificity of DNA-cleaving ribozymes

Ribozyme	Mutations	Positions 271/312	DNA			RNA		Specificity (DNA/RNA) ⁱ
			k_{cat} ^c (min ⁻¹)	K_m ^c (μ M)	k_{cat}/K_m (10 ⁷ M ⁻¹ min ⁻¹)	k_{cat}/K_m ^d (10 ⁷ M ⁻¹ min ⁻¹)		
Wild-type ^a	0	U/G	$2.4(\pm 0.2) \times 10^{-4}$	6.0 ± 1.7	$4.0(\pm 1.6) \times 10^{-6}$	0.97 ± 0.19	$4.1(\pm 2.6) \times 10^{-6}$	
G27 48 ^b	17	U/A	0.67 ± 0.02	0.21 ± 0.03	0.32 ± 0.05	2.6 ± 0.05	0.12 ± 0.02	
G45 8	21 ^e	C/AA	0.21 ± 0.01	0.043 ± 0.007	0.48 ± 0.1	0.60 ± 0.02	0.81 ± 0.2	
G63 19	29 ^f	C/AA	0.26 ± 0.01	0.016 ± 0.002	1.6 ± 0.2	0.69 ± 0.02	2.4 ± 0.3	
Site-directed mutants:								
G63 19	29	C/A ^g	0.10 ± 0.00	0.028 ± 0.003	0.35 ± 0.05	0.43 ± 0.02	0.82 ± 0.2	
G63 19	28	C/G ^g	0.021 ± 0.001	0.0092 ± 0.002	0.23 ± 0.05	0.30 ± 0.07	0.75 ± 0.4	
G63 19	28	U/AA ^h	1.5 ± 0.1	0.33 ± 0.07	0.47 ± 0.1	1.2 ± 0.08	0.40 ± 0.2	
G63 19	28	U/A ^g	1.1 ± 0.1	0.13 ± 0.03	0.94 ± 0.4	1.4 ± 0.04	0.67 ± 0.3	
G63 19	27	U/G ^g	0.44 ± 0.02	0.042 ± 0.005	1.1 ± 0.2	1.3 ± 0.03	0.82 ± 0.1	

^a Data obtained previously (Beaudry & Joyce, 1992), modified slightly as a result of subsequent statistical analysis.

^b Data obtained previously (Tsang & Joyce, 1994).

^c Determined under single-turnover conditions ($[E] \gg [S]$), as described in Materials and Methods. Data were fit to the equation: $k_{obs} = k_{cat} [E]/([E] + K_m)$, which holds true when $[S] \ll K_m$; k_{obs} was obtained from the equation: $y = 1 - e^{-k_{obs}t}$, where y = fraction substrate cleaved at time t for a range of $[E]$ spanning K_m .

^d Determined under single-turnover conditions, as described in Materials and Methods. Data were fit to the equation: $k_{obs} = (k_{cat}/K_m) [E]$, where k_{obs} is the initial rate of the reaction at varying $[E]$ when $[E] \ll K_m$.

^e 44:G → A, 51:52:CUAA insert, 86/87:UA → del, 94:A → U, 115/116:AG → UA, 165:C → U, 170:C → U, 188:G → A, 190/191:UG → AU, 205:U → C, 215:G → A, 239:U → A, 271:U → C, 289:U → A, 312:G → AA, 340:U → A, 364:C → U, and 366:G → A.

^f 44:G → A, 51:G → A, 51/52:CUAA insert, 86/87:UA → del, 94:A → U, 115/116:AG → UA, 138:C → A, 165:C → U, 170:C → U, 175:G → A, 188:G → A, 190/191:UG → AU, 205:U → C, 215:G → A, 239:U → A, 271:U → C, 288/289:GU → AA, 292:U → A, 312:G → AA, 334:A → G, 340:U → A, 347:A → G, 366:G → A, 389:U → C, and 390:A → C.

^g Mutations introduced by template mutagenesis (see Materials and Methods).

^h Mutations introduced by nested PCR.

ⁱ Ratio of k_{cat}/K_m for DNA cleavage *versus* RNA cleavage.

steadily. By generation 63, k_{cat}/K_m values had reached $8 \times 10^6 \text{ M}^{-1} \text{ min}^{-1}$ and $9 \times 10^6 \text{ M}^{-1} \text{ min}^{-1}$ for the DNA and RNA-cleavage reactions, respectively, measured for the population as a whole.

Comparison of individual ribozymes

Individual ribozymes were isolated from the population at nine-generation intervals from generation 27 through 63 using a shotgun cloning procedure (see Materials and Methods). Representative individuals were chosen from generations 27, 45, and 63 for formal kinetic analysis (Table 1). These ribozymes were representative of the population from which they were cloned because they contained the typical number and constellation of mutations that occurred in the population.

The G63 19 ribozyme catalyzed the DNA-cleavage reaction with a k_{cat}/K_m value of $1.6 \times 10^7 \text{ M}^{-1} \text{ min}^{-1}$, about fivefold more efficiently than the G27 48 ribozyme. This higher catalytic efficiency was due to a 13-fold lower K_m that was partially offset by a 2.6-fold lower k_{cat} . In contrast, the G63 ribozyme catalyzed RNA cleavage about fourfold less efficiently compared with the G27 ribozyme. The preference for DNA *versus* RNA substrates, as determined by the ratio of k_{cat}/K_m values for the respective cleavage reactions, improved about 20-fold, from 0.12 for the G27 ribozyme to 2.4 for the G63 ribozyme. The DNA-cleavage reaction proceeded to completion when carried out in the presence of an excess amount of either the G27 or G63 ribozyme. In contrast, the RNA-cleavage reaction did not

proceed to completion, reaching about 40% cleaved for the G27 ribozyme and only about 15% cleaved for the G63 ribozyme (Figure 4).

Evolutionary changes in genotype

In order to determine which genotypic changes were responsible for the improved phenotype of the evolved population, sequence data were obtained from 25 randomly chosen individuals, isolated from the population every ninth generation from G27 through G63, as summarized diagrammatically in Figure 5. The mean number of mutations per cloned individual, relative to the wild-type, increased from 17 at G27 to 27 at G63, reflecting the continual accumulation of mutations that occurred during the *in vitro* evolution process (Figure 6(a)). However, the genetic diversity of the population, as measured by the Shannon entropy statistic (see Materials and Methods), declined steadily between G0 and G36. In order to increase diversity, new mutations were introduced at an enhanced rate through successive mutagenic PCR procedures, performed at G36, G45 and G54. This resulted in increased genetic diversity between G45 and G63 (Figure 6(b)).

Prior to generation 18, mutations accumulated in both the phylogenetically conserved portions of the molecule that were randomized in the initial population and the peripheral regions that were not randomized (Figure 6(a)). After G18, however, mutations tended to accumulate in the periphery but not in the conserved core. Accordingly, the peripheral regions became more genetically diverse

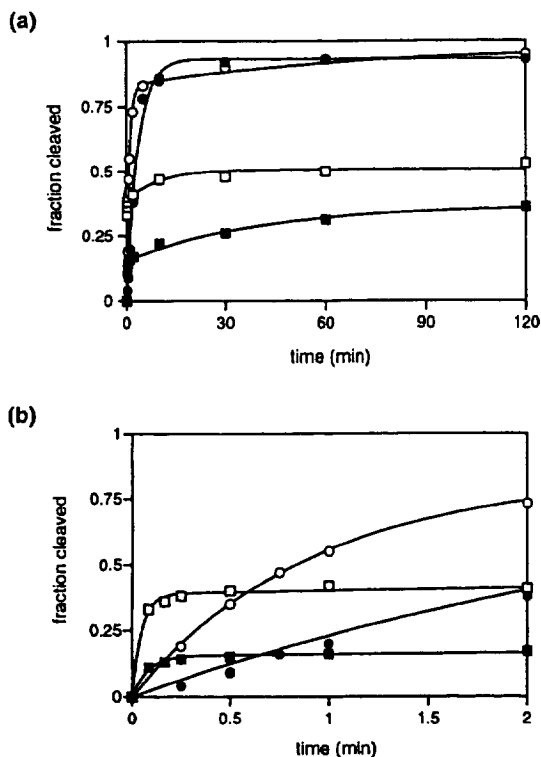

Figure 4. Comparison of the extent of the DNA and RNA-cleavage reactions catalyzed by the G27 48 and G63 19 ribozymes. Reactions were carried out in the presence of 2.5 μ M ribozyme and trace amounts (<1 nM) of either RNA or DNA substrate. (○) DNA cleavage by G27 48; (●) DNA cleavage by G63 19; (□) RNA cleavage by G27 48; (■) RNA cleavage by G63 19. (a) Time course over 120 minutes. (b) Expanded view of the reaction over the first two minutes. Data for RNA cleavage and DNA cleavage by G27 8 were fit to a biphasic exponential equation with a fast phase followed by a slow phase. Data for DNA cleavage by G63 19 were fit to a single exponential equation. All curve fits were based on the complete data set obtained over 120 minutes.

while the core became more homogenous (Figure 6(b)). By generation 63, the majority of mutations occurred in the periphery.

Two major genotypic changes first appeared in the population at G36. The first, a C₄UAA insert located between nucleotide positions 51 and 52 within the P2 stem (Figure 1), was present in >90% of the clones at G36, replacing the NGAA insert that had occurred with a frequency of 30% at G27. The second, a C \rightarrow U mutation at position 165 within P5c was present in >90% of the clones at G36, replacing a C \rightarrow A change at the adjacent position 166 that had occurred in nearly all of the clones at G27. Between G36 and G45, five new mutations became dominant (>90% frequency) in the population. Three of these mutations, 271:U \rightarrow C, 289:U \rightarrow A, and 312:G \rightarrow AA, occurred within the catalytic core of the ribozyme and two, 340:U \rightarrow A and 364:C \rightarrow U, occurred in the peripheral P9 stem. Between G45 and G63, no new mutations rose to dominance in the population. Yet, the

mean number of mutations per cloned individual continued to rise as a result of various low-frequency changes that occurred in the P9 and L8 peripheral regions.

Analysis of specific mutations

Two of the mutations within the catalytic core, 271:U \rightarrow C and 312:G \rightarrow AA, were chosen for more detailed analysis. Both of these changes were observed in all 25 clones that were obtained at G45 and G54 and in 24 of 25 clones that were obtained at G63. No individual was found that contained only one of these two mutations, suggesting that they operate in concert to confer selective advantage to the ribozyme. The single individual at G63 that lacked the two mutations contained instead the wild-type nucleotide U at position 271 and a G \rightarrow A change at position 312. Previous studies had shown that the 312:G \rightarrow A mutation occurred in a mutually exclusive fashion with regard to the concerted mutations 313:G \rightarrow Y and 314:A \rightarrow G (Beaudry & Joyce, 1992; Tsang & Joyce, 1994). Over the course of evolution, 313:G \rightarrow Y and 314:A \rightarrow G nearly always occurred together, as their frequency rose, then fell, then rose again, and finally fell to extinction (Figure 7). The 312 mutation similarly rose and fell but in opposite phase relative to the 313:G \rightarrow Y and 314:A \rightarrow G mutations. Prior to G36, the 312 mutation occurred as a G \rightarrow A change, but following G36 it occurred as a G \rightarrow AA change.

Against the background of the G63 19 ribozyme, we reverted the 271:U \rightarrow C mutation to the wild-type U and the 312:G \rightarrow AA mutation to either the wild-type G or a single A. All pairwise combinations of these mutations were prepared, and their effect on the RNA-catalyzed phosphoester transfer reaction involving either an RNA or DNA substrate was analyzed (Table 1). Reversion of both mutations to the wild-type state resulted in only a slight decrease in the efficiency of DNA cleavage, while reversion of either mutation alone led to a more substantial decrease (Figure 8). The 271:U \rightarrow C mutation, regardless of whether the 312 position was G, A or AA, resulted in lower RNA-cleavage activity. The 271:U \rightarrow C mutation also resulted in a lower k_{cat} value for DNA cleavage, but this was compensated by a much lower K_m value. The 312:G \rightarrow AA change resulted in a significantly higher k_{cat} value for DNA cleavage, regardless of whether the 271 position was U or C. However, for 271:U, but not for 271:C, this was accompanied by a substantial increase in K_m value. In summary, the 271:U \rightarrow C and 312:G \rightarrow AA mutations were synergistic: together they provided the greatest improvement in DNA-cleavage activity while diminishing RNA-cleavage activity.

This mutational analysis clearly demonstrates the selective advantage of the concerted nucleotide mutations at positions 271 and 312. These two changes, however, do not explain all of the improvement in DNA *versus* RNA-cleavage activity

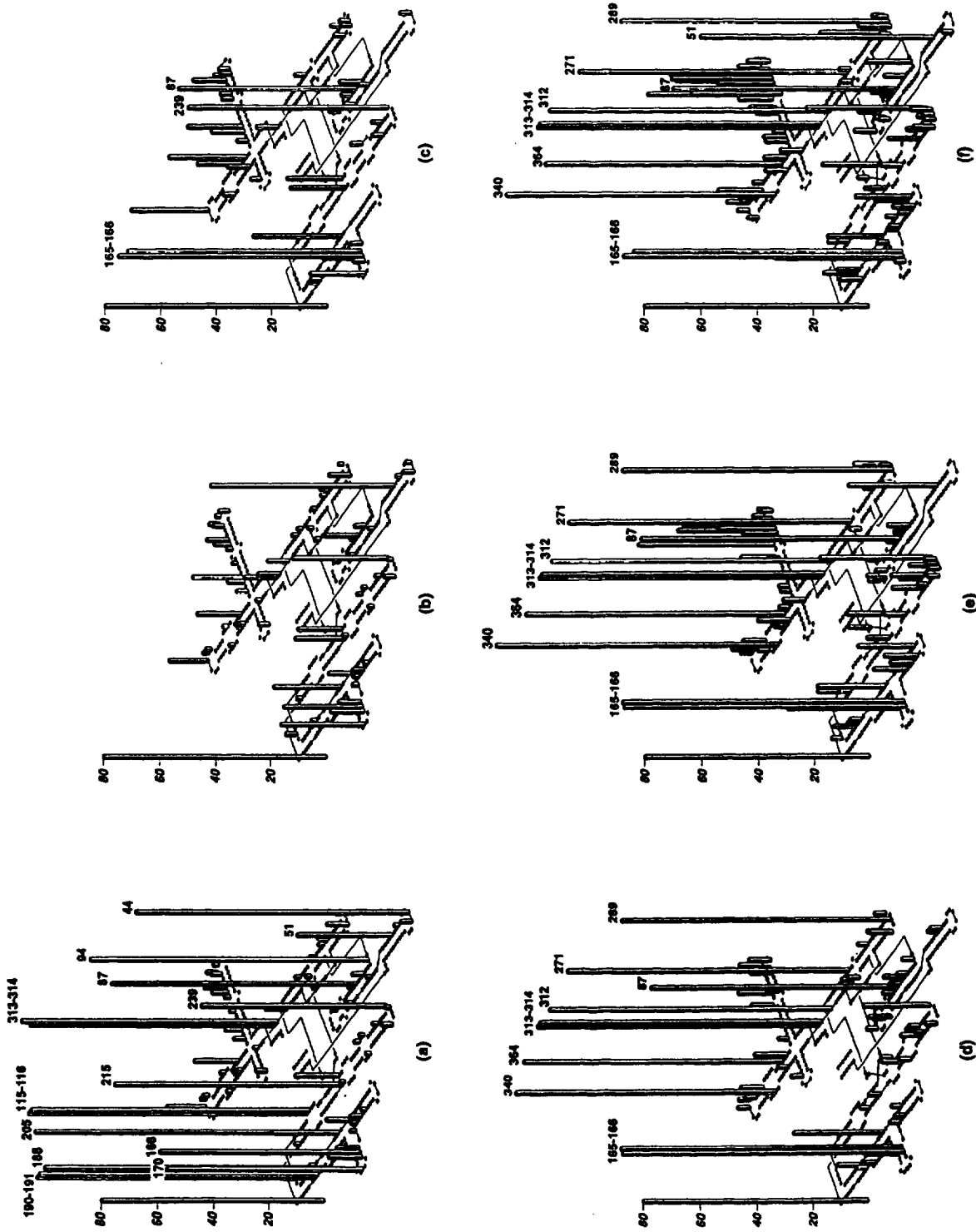

Figure 5. Sites at which mutations occurred over the course of evolution, superimposed on the secondary structure of the *Tetrahymena* ribozyme. Box height corresponds to the frequency of mutations (%) at each nucleotide position, on the basis of 50 subclones sequenced at G27, and 25 subclones sequenced at G36, G45, G54, and G63. Non-mutable primer binding sites are shaded; substrate is shown in black. Commonly occurring mutations (> 50% frequency) are labeled. (a) G27 (Tsang & Joyce, 1994); (b) G27, normalized such that mutations occurring with > 50% frequency were assigned a value of 0% in this and subsequent panels; (c) G36; (d) G36; (e) G45; (f) G45.

that occurred between G27 and G63. Even when both mutations were reverted to the G27 state (271:U; 312:A) on the G63 19 background, the ratio of DNA to RNA-cleavage activity was still significantly greater than that of the G27 48 ribozyme. Therefore, other mutations that arose between G27 and G63 must contribute to the enhanced substrate specificity of the evolved ribozymes, such as those that occurred in the P9 and L8 regions.

Discussion

Preference for DNA versus RNA substrates

We have described a novel *in vitro* evolution strategy that simultaneously selects for cleavage of DNA and against binding of RNA, leading to specialization of the DNA-cleaving activity of a group I ribozyme. Beginning with a heterogeneous population of ribozymes that cleave both RNA and DNA substrates, we applied this strategy for 36 generations of *in vitro* evolution and obtained a 50-fold increase in DNA-cleavage activity and a twofold decrease in RNA-cleavage activity, corresponding to an overall increase of 100-fold in the preference for DNA over RNA substrates. From the evolved population at G63, we isolated a ribozyme that cleaves DNA more efficiently than it cleaves RNA, with a catalytic efficiency, k_{cat}/K_m , of $2 \times 10^7 \text{ M}^{-1} \text{ min}^{-1}$ and $7 \times 10^6 \text{ M}^{-1} \text{ min}^{-1}$ for the DNA and RNA-cleavage reactions, respectively. Site-directed mutagenesis experiments confirm the selective advantage of two covarying mutations at nucleotide positions 271 and 312 within the catalytic core of the ribozyme that are largely responsible for this modified behavior.

Our selection regime required that the ribozymes cleave a DNA substrate in the presence of an RNA inhibitor that corresponds to the 5' product generated by the RNA-catalyzed RNA-cleavage reaction. Ribozymes with enhanced affinity for the DNA substrate were more likely to avoid inhibition by the RNA product. Under pseudo-first-order, single-turnover conditions (see Materials and Methods), substrate binding is reflected by K_m , the concentration of ribozyme that is required to obtain the half-maximal first-order rate of reaction. The G63 19 ribozyme catalyzed the DNA-cleavage reaction with a K_m value that is 13-fold lower than that of the G27 ribozyme. Thus, the G63 ribozyme's enhanced preference for DNA versus RNA substrates compared to the G27 ribozyme may be due, at least in part, to the G63 ribozyme's greater affinity for the DNA substrate.

Ribozymes that bound the RNA product more slowly also would have had an increased likelihood of escaping inhibition by the RNA product under our selection conditions, assuming that the rate of DNA substrate binding did not decrease as well. Changes in RNA binding rates may explain the differing maximal extent of RNA cleavage by the

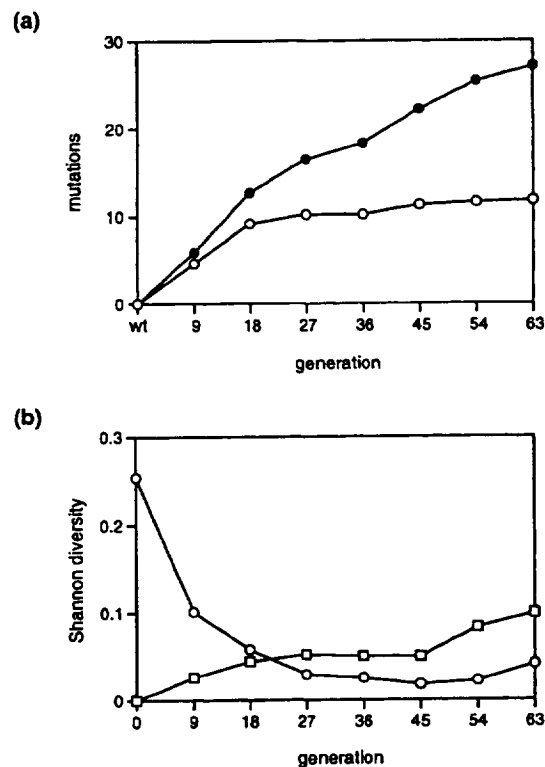

Figure 6. Genotypic change over 63 generations of *in vitro* evolution. (a) Mean number of mutations per individual, pertaining to the entire ribozyme (●) or the 140 nucleotides within the catalytic core that were partially randomized in the initial population (○). Data for G9 are from Beaudry & Joyce (1992); data for G18 and G27 are from Tsang & Joyce (1994). (b) Shannon diversity of randomized core (○) and peripheral regions (□), calculated as described in Materials and Methods.

G27 and G63 ribozymes: G27 48 cleaves RNA to a maximal extent of ~40%, while G63 19 reaches only ~15%. For the wild-type *Tetrahymena* ribozyme, incomplete cleavage of the RNA substrate occurs because an internal equilibrium is established between the forward and reverse reactions due to slow dissociation of the product (Mei & Herschlag, 1996). A similar situation may exist for the G27 and G63 ribozymes. If the rate of the reverse reaction is similar for these two ribozymes, then the lesser extent of RNA cleavage by G63 19 compared with G27 48 is likely due to the slower rate of forward reaction for the former.

Genetic basis for the evolved phenotype

Site-directed mutagenesis experiments indicate that covarying mutations at positions 271 and 312 in the G63 19 ribozyme contribute to its preference for DNA versus RNA substrates (Table 1). Both of these mutations disrupt phylogenetically conserved base-pairing interactions within the catalytic core (see Figure 1). The 271:U → C mutation disrupts what is thought to be a reverse Hoogsteen pair between 103A and 271U, located at the end of the

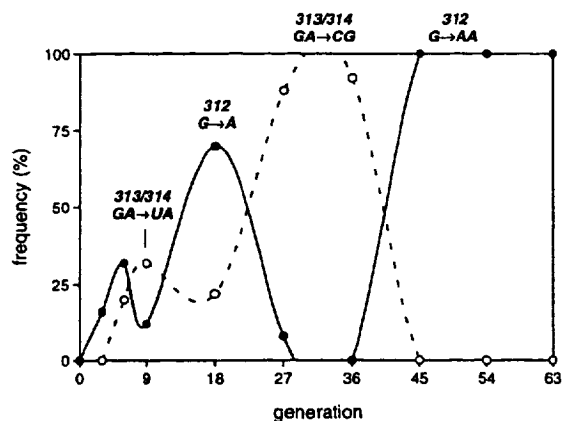

Figure 7. Frequency of mutually exclusive mutations at positions 312 (●) and 313/314 (○) over the course of *in vitro* evolution. Data obtained at discrete times were fit to a spline curve. The 312:G → A mutation was not detected between G27 and G36, but reappeared beginning at G45 as 312:G → AA. The 313/314:GA → UG mutation was replaced with 313/314:GA → CG beginning at G27, but was not detected at G45 and thereafter.

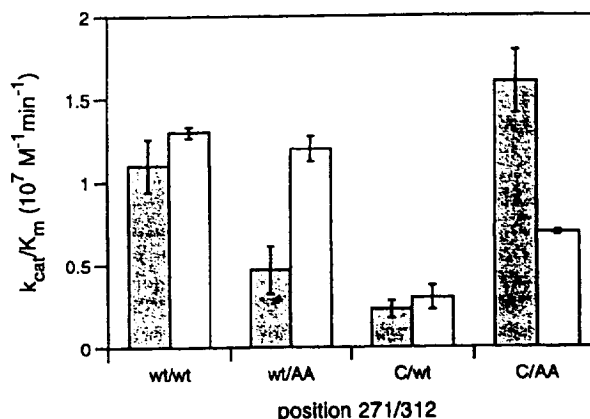

Figure 8. Co-dependence of the 271:U → C and 312:G → AA mutations with regard to enhanced preference for DNA versus RNA substrates. The k_{cat}/K_m values for the DNA (filled) and RNA (open) cleavage reactions were determined for ribozymes containing neither, either, or both of the 271 and 312 mutations in the context of the G63 19 ribozyme.

P3 stem (Kim & Cech, 1987; Green *et al.*, 1990). The 312:G → AA mutation disrupts the 262C:312G Watson-Crick pair, which lies within the P7 stem adjacent to the 264G:311C base-pair that forms a base-triple with the bound guanosine nucleophile (Michel *et al.*, 1989). By disrupting the local structure near the G-binding site, the 271 and 312 mutations may alter the orientation of the attacking 3'-terminal guanosine relative to the target phosphate, differentially affecting the DNA versus RNA-cleavage reactions. Although covarying mutations are often observed between two interacting components of an enzyme, the nucleotides at positions 271 and 312 are unlikely to interact directly because they are located at opposite ends of the P7 stem. Their codependent behavior more likely results from indirect interactions. Other mutations that contribute to the altered phenotype, including those in the L8 and P9 regions, occur outside the catalytic core of the ribozyme, suggesting that they too exert their influence via indirect or long range effects.

Residues in the J8/7 region of the wild-type *Tetrahymena* ribozyme have been shown to interact directly with 2'-hydroxyl groups of the substrate strand of the P1 duplex (Pyle *et al.*, 1992). Thus, we expected that selection against RNA binding would lead to mutations in this region. Yet, J8/7 proved to be highly resistant to mutation over the course of *in vitro* evolution. Not a single individual among the 100 that were isolated from generations 36, 45, 54, and 63 had a mutation in this region. Furthermore, when we intentionally mutated nucleotide position 302, which in the wild-type ribozyme interacts with a particular 2'-hydroxyl of the RNA substrate, we observed a near-complete loss of DNA-cleavage activity (data not shown). Therefore, despite the absence of 2'-hydroxyl

groups in the DNA substrate, specific nucleotides within J8/7 appear to be critical for DNA-cleavage activity.

Although the G63 19 ribozyme contains 29 mutations relative to the wild-type sequence and cleaves RNA fourfold less efficiently than the G27 48 ribozyme, it still cleaves RNA quite readily, with a k_{cat}/K_m value of $6.9 \times 10^6 \text{ M}^{-1} \text{ min}^{-1}$, which is similar to the wild-type level of $9.7 \times 10^6 \text{ M}^{-1} \text{ min}^{-1}$. The ribozyme's ability to tolerate a large number of mutations suggests that it is overspecified with respect to RNA-cleavage activity. More dramatic sequence or structural alterations may be necessary in order to achieve a substantial reduction in this activity. However, elimination of RNA-cleavage activity without significant reduction of DNA-cleavage activity is likely to be difficult to achieve for several reasons. Firstly, the ribose at the cleavage site is inherently more reactive than deoxyribose, contributing, in the case of the wild-type *Tetrahymena* ribozyme, $\sim 10^3$ -fold towards stabilization of the transition state compared with deoxyribose (Herschlag *et al.*, 1993). Secondly, RNA/RNA homoduplexes are more stable than DNA/RNA heteroduplexes, resulting in inherently greater binding affinity for RNA compared to DNA substrates (Roberts & Crothers, 1993). Thirdly, both RNA/RNA and RNA/DNA duplexes tend to adopt A-form helices (Wang *et al.*, 1980; Sanger, 1984; Egli *et al.*, 1992), making it difficult for the ribozyme to distinguish them, especially if the ribozyme is to maintain generality with respect to the sequence of the ribozyme/substrate pairing. Fourthly, steric conflicts involving 2'-hydroxyl groups, which might reduce RNA-cleavage activity, may not be substantial due to the small size of these groups. Considering the inherent advantages of a ribose compared to deoxyribose-containing substrate, it is remarkable

that the latter is cleaved more efficiently by the evolved ribozyme.

Evolutionary search for fitness optima

In vitro evolution experiments provide an opportunity to examine the genotypic and phenotypic responses of an evolving population to controlled selection pressures. Our test-tube population of ribozymes displayed some of the tendencies of other artificially and naturally-evolving populations, including the occurrence of synergistic and mutually exclusive traits. For example, over the course of 63 generations of evolution, the DNA-cleaving ribozymes generally possessed either a mutation at position 312 or a pair of concerted mutations at positions 313 and 314. These two alternatives were mutually exclusive, alternately rising and falling in abundance (Figure 7). Lehman & Joyce (1993) observed a similar response in an evolving population of Ca^{2+} -dependent RNA-cleaving ribozymes. Such complex behavior demonstrates that artificially-evolving populations, like natural populations, exhibit an adaptive response that fluctuates as variants of variants are generated over the course of evolution.

Despite increasing diversity in the evolving population between generation 45 and 63, phenotypic improvements were modest and genotypic changes occurred predominantly in the peripheral regions of the ribozyme. Few mutations were acquired in the critical core regions, where diversity remained low (Figure 6(a) and (b)). These results suggest that the evolved population may have become trapped in a local fitness optimum. Achieving a higher level of fitness might require traversing less advantageous intermediates, for example, by exploring a much wider distribution of variants or by restarting the evolution process at an earlier generation. Alternatively, the continued accumulation of neutral mutations, in peripheral regions, for example, might enable the population to bypass less favorable intermediates and reach a state of improved fitness through a global change in the secondary structure of the ribozyme (Schuster *et al.*, 1994; Schuster, 1995).

In this study, we demonstrated that by selecting for DNA cleavage and against RNA binding, one can enhance the specificity of a group I ribozyme for DNA *versus* RNA substrates. Greater specificity might be obtained by carrying out additional rounds of *in vitro* evolution under increasingly stringent selection conditions, perhaps employing higher concentrations of RNA inhibitor or shorter incubation times. Alternatively, increased preference for DNA *versus* RNA substrates might be achieved by focusing the selection pressure exclusively on the DNA-cleavage reaction, seeking maximal activity with a DNA substrate and expecting, as some have argued (Eaton *et al.*, 1995), that improved specificity will follow automatically. Because the evolved DNA-cleaving ribozymes are

already efficient catalysts, adopting this strategy will require the introduction of extremely stringent selection constraints that may be technically more difficult to implement. Of course, whether further improvement is even possible depends ultimately on the functional flexibility of the group I catalytic motif and the catalytic potential of RNA.

Materials and Methods

Materials

Unlabeled nucleoside triphosphates (NTPs) and deoxynucleoside triphosphates (dNTPs) were purchased from Pharmacia, and dideoxynucleoside triphosphates (ddNTPs) were from U.S. Biochemical. [α - ^{32}P]GTP, [γ - ^{32}P]ATP, and [^3H]UTP were from ICN Radiochemicals. Synthetic oligodeoxynucleotides were obtained from Operon Technologies and purified by polyacrylamide gel electrophoresis and subsequent chromatography on either Sephadex G-25 or DuPont Nensorb 20. Synthetic oligoribonucleotides were obtained from Oligos Etc. and purified by gel electrophoresis and subsequent chromatography on DuPont Nensorb. Bacteriophage T4 polynucleotide kinase was from New England Biolabs, calf intestine phosphatase from Boehringer, avian myeloblastosis virus (AMV) reverse transcriptase from Life Sciences, and Moloney murine leukemia virus (MoMLV) reverse transcriptase, Sequenase 2.0 (modified bacteriophage T7 DNA polymerase), T4 DNA ligase, and T4 DNA polymerase from U.S. Biochemical. T7 RNA polymerase was prepared as described (Davanloo *et al.*, 1984) and purified according to a procedure originally developed for SP6 RNA polymerase (Butler & Chamberlin, 1982). Streptavidin immobilized on agarose beads was obtained from Sigma and streptavidin-containing pipette tips (Affinitips) were from Genosys.

In vitro evolution protocol

Starting with the G27 population, *in vitro* evolution was carried out as described (Tsang & Joyce, 1994), with the following modifications. (1) The DNA-cleavage reaction was performed in the presence of an RNA inhibitor, consisting of the 5'-product portion of the RNA substrate, 5'-GGCCUCU-3'. Generally, 0.1 to 2% of the population underwent the target reaction and was selectively amplified. The concentration of inhibitor was increased when the reacted portion of the population surpassed 2%, in order to maintain a strong selective advantage for the more substrate-specific DNA-cleaving ribozymes. Over the 36 generations the inhibitor concentration was increased from 0.1 to 2 μM . (2) At G37, the ribozyme concentration was increased from 0.1 μM to 1 μM , and the incubation time was increased from five minutes to one hour in order to give ribozymes with lower activity but higher specificity the opportunity to react with the DNA substrate. (3) In order to prevent isothermal amplification artifacts, reacted ribozymes were purified away from non-reacted molecules using either of two methods. From generation 28 through 36, the ribozyme population was challenged with a 3'-biotinylated DNA substrate so that reacted molecules became tagged with the biotinylated portion of the substrate. Active molecules were isolated by binding to streptavidin immobilized on agarose beads. Non-specific binders were removed by extensive washing with a solution containing 1 M NaCl, 50 mM Tris (pH 7.5), 5 mM

EDTA. The agarose-bound molecules were then amplified in an isothermal reaction, as described (Tsang & Joyce, 1994). The agarose beads did not significantly affect the efficiency of amplification. From G37 through G63, reacted ribozymes were separated from non-reacted ones by denaturing polyacrylamide gel electrophoresis, then eluted from the gel and purified by chromatography on DuPont Nensorb. (4) New mutations were introduced into the population at generations 36, 45, and 54 through mutagenic PCR (Cadwell & Joyce, 1992; Cadwell & Joyce, 1994). The mutagenic PCR was seeded with cDNA obtained by reverse transcription of RNA that had been purified by gel electrophoresis. The same primers were used in both the standard and mutagenic PCR: 5'-CGAGTACTCCAAAATAATC-3' (primer 1b) and 5'-CTGCAGAAATTCTAATACGACTCACTATAGGAGG-GAAAAGTTATCAGGC-3' (primer 2). At G36, two consecutive rounds of mutagenic PCR were carried out, providing an expected mutation rate of 1.4% per nucleotide position; at G45 and G54, three consecutive rounds were carried out, providing an expected mutation rate of 2% per position. In each case, the cDNA strand was isolated and purified by polyacrylamide gel electrophoresis prior to seeding the next round of mutagenic PCR. (5) Our standard PCR protocol was altered slightly between G45 and G63, reducing the number of temperature cycles from 30 to 15, and carrying out two consecutive 15-cycle amplification reactions. This was done in order to prevent PCR artifacts and to reduce the amount of carryover material from one generation to the next.

Kinetic analysis

All kinetic analyses were carried out under single-turnover conditions with ribozyme (E) in large excess over substrate (S), and the concentration of S at least tenfold below K_m . Ribozymes were preincubated for 15 minutes at 37°C in a 17 μ l solution containing 10 mM MgCl₂ and 30 mM 4-(2-hydroxyethyl)piperazine-1-propanesulfonic acid (EPPS) (pH 7.5). A total of 3 μ l of substrate in the same solution was added to initiate the reaction, and 3 μ l aliquots were removed at the appropriate times and quenched by the addition of one to two volumes of an ice-cold mixture containing 8 M urea, 50 mM to 100 mM EDTA, 0.05% (w/v) xylene cyanol, 0.05% (w/v) bromophenol blue, 10% (w/v) SDS, 9 mM Tris-borate (pH 8.3), and 20% (w/v) sucrose. The k_{cat}/K_m values were calculated from the slope of the best fit line obtained by plotting k_{obs} versus [E] for at least four different subsaturating concentrations of E. The k_{cat} and K_m values were determined individually for the DNA-cleavage reaction by plotting k_{obs} over a range of ribozyme concentrations that spanned K_m . Data were fit to the equation: $k_{obs} = k_{cat}/([E] + K_m)$, which holds true when $[S] \ll K_m$, assuming that binding of the ribozyme and substrate has reached pre-equilibrium. The standard errors reported for k_{cat} and K_m values were determined based on the fit to this equation by non-linear regression using the Marquardt-Levenberg algorithm (Sigma Plot). The k_{cat} value for RNA cleavage was considerably faster than 1 min⁻¹ and thus not measurable using manual pipetting methods. Determination of kinetic parameters on different days and with different preparations of material generally varied by less than 20%. DNA and RNA-cleavage assays were carried out using the same preparation of ribozyme transcript and generally in a side-by-side fashion to obtain the most accurate measurement of the ratio of DNA to RNA-cleavage activity.

Preparation of ribozymes and substrates

Individual ribozymes were isolated by shotgun cloning using the Invitrogen TA Cloning Kit. Sequencing of clones and preparation of individual ribozymes were carried out as described (Tsang & Joyce, 1994). Preparation of DNA and RNA substrates and procedures for cDNA synthesis, PCR, and *in vitro* transcription reactions all were performed as described.

Site-directed mutagenesis

Mutations were made at specific positions in the ribozyme using a template-directed mutagenesis procedure (Joyce & Inoue, 1982). The non-template strand was prepared by amplifying the ribozyme-encoding gene by PCR using a 5'-biotinylated primer for the template strand and a standard primer for the non-template strand. The PCR products were purified by phenol extraction and ethanol precipitation, then bound to a streptavidin-containing matrix (Affinitip) and washed with 0.2 N NaOH to denature and elute the non-biotinylated, non-template strand. The eluate was neutralized with HCl, and the non-template strand was concentrated and purified by ethanol purification. The 5'-phosphorylated oligos that introduce the desired mutations (5'-CCCCGACCGACATTTAGTCTGTGAACTGC-3' and 5'-CTCCCATTAAGGAGAGGTCYACTATATCTTAT-GAGAAG-3', Y = C or T) together with an oligo that defines the 3' end of the template (primer 1b) were annealed to the non-template strand, and the gaps were filled with T4 DNA polymerase and ligated with T4 DNA ligase. RNA was transcribed from the reconstructed double-stranded DNA, reverse transcribed to cDNA, amplified by PCR, subcloned, and sequenced. Individual ribozymes that contained the appropriate mutation were prepared in the usual manner. In the case of the 271:C \rightarrow U mutation, site-directed mutagenesis was carried out using a nested PCR strategy. First, PCR was performed using the mutagenic oligo 5'-CCCCGACCGACATTTAGTCTGTGAACTGC-3' and primer 2. The ~250 nt product was purified using a Microspin S-300 HR column (Pharmacia) and ethanol precipitated. This product was used as primer in a subsequent PCR reaction with primer 1b. The full-length (~400 nt) PCR product was purified in a low-melting point agarose gel and recovered by phenol extraction and ethanol precipitation, and the mutant ribozyme was prepared in the usual manner.

Diversity estimation

Diversity in a population of genotypes was estimated by averaging, over all 353 variable nucleotide positions, the diversity at each position using the formula: $H = \sum p_i(\ln p_i)$, where p_i is the frequency of a particular nucleotide base (A, C, G, or U). Diversity is maximal when A, C, G, and U occur with equal frequency.

Acknowledgements

We thank Dan Herschlag, Niles Lehman, and Rui Mei for helpful discussions. This work was supported by research grant AI 30882 from the National Institutes of Health.

References

- Beaudry, A. A. & Joyce, G. F. (1992). Directed evolution of an RNA enzyme. *Science*, **257**, 635–641.
- Been, M. D. & Perotta, A. T. (1991). Group I intron self-splicing with adenosine: evidence for a single nucleoside-binding site. *Science*, **252**, 434–437.
- Bevilacqua, P. C. & Turner, D. H. (1991). Comparison of binding of mixed ribose-deoxyribose analogues of CUCU to a ribozyme and to GGAGAA by equilibrium dialysis: evidence for ribozyme specific interactions with 2'-OH groups. *Biochemistry*, **30**, 10632–10640.
- Bevilacqua, P. C., Kierzek, R., Johnson, K. A. & Turner, D. H. (1992). Dynamics of ribozyme binding of substrate revealed by fluorescence-detected stopped-flow methods. *Science*, **258**, 1355–1358.
- Breaker, R. R. & Joyce, G. F. (1994). Inventing and improving ribozyme function: rational design versus iterative selection methods. *Trends Biotech.* **12**, 268–275.
- Butler, E. T. & Chamberlin, M. J. (1982). Bacteriophage SP6-specific RNA polymerase. Isolation and characterization of the enzyme. *J. Biol. Chem.* **257**, 5772–5778.
- Cadwell, R. C. & Joyce, G. F. (1992). Randomization of genes by PCR mutagenesis. *PCR Methods Applic.* **2**, 28–33.
- Cadwell, R. C. & Joyce, G. F. (1994). Mutagenic PCR. *PCR Methods Applic.* **3**, S136–S140.
- Cech, T. R., Damberger, S. H. & Gutell, R. R. (1994). Representation of the secondary and tertiary structure of group I introns. *Nature Struct. Biol.* **1**(5), 273–280.
- Davanloo, P., Rosenberg, A. H., Dunn, J. J. & Studier, F. W. (1984). Cloning and expression of the gene for bacteriophage T7 RNA polymerase. *Proc. Natl Acad. Sci. USA*, **81**, 2035–2039.
- Eaton, B. E., Gold, L. & Zichi, D. A. (1995). Let's get specific: the relationship between specificity and affinity. *Chemistry & Biology*, **2**, 633–638.
- Egli, M., Usman, N., Zhang, S. & Rich, A. (1992). Crystal structure of an Okazaki fragment at 2-Å resolution. *Proc. Natl Acad. Sci. USA*, **89**, 534–538.
- Green, R., Ellington, A. D. & Szostak, J. W. (1990). *In vitro* genetic analysis of the *Tetrahymena* self-splicing intron. *Nature*, **347**, 406–408.
- Herschlag, D. (1992). Evidence for processivity and two-step binding of the RNA substrate from studies of the J1/2 mutants of the *Tetrahymena* ribozyme. *Biochemistry*, **31**, 1386–1399.
- Herschlag, D. & Cech, T. R. (1990). Catalysis of RNA cleavage by the *Tetrahymena thermophila* ribozyme. 1. Kinetic description of the reaction of an RNA substrate complementary to the active site. *Biochemistry*, **29**, 10159–10171.
- Herschlag, D., Eckstein, F. & Cech, T. R. (1993). The importance of being ribose at the cleavage site in the *Tetrahymena* ribozyme reaction. *Biochemistry*, **32**, 8312–8321.
- Joyce, G. F. & Inoue, T. (1989). A novel technique for the rapid preparation of mutant RNAs. *Nucl. Acids Res.* **17**, 711–722.
- Kim, S.-H. & Cech, T. R. (1987). Three-dimensional model of the active site of the self-splicing rRNA precursor of *Tetrahymena*. *Proc. Natl Acad. Sci. USA*, **84**, 8788–8792.
- Lehman, N. & Joyce, G. (1993). Evolution *in vitro* of an RNA enzyme with altered metal dependence. *Nature*, **361**, 182–185.
- Lorsch, J. R. & Szostak, J. W. (1996). Chance and necessity in the selection of nucleic acid catalysts. *Acc. Chem. Res.* **29**(2), 103–110.
- Mei, R. & Herschlag, D. (1996). Mechanistic investigations of a ribozyme derived from the *Tetrahymena* group I intron. Insights into catalysis and the second step of splicing. *Biochemistry*, **35**, 5796–5809.
- Michel, F., Hanna, M., Green, R., Bartel, D. P. & Szostak, J. W. (1989). The guanosine binding site of the *Tetrahymena* ribozyme. *Nature*, **342**, 391–395.
- Pyle, A. M. & Cech, T. R. (1991). Ribozyme recognition of RNA by tertiary interactions with specific ribose 2'-OH groups. *Nature*, **350**, 628–631.
- Pyle, A. M., Murphy, F. L. & Cech, T. R. (1992). RNA substrate binding site in the catalytic core of the *Tetrahymena* ribozyme. *Nature*, **358**, 123–128.
- Roberts, R. W. & Crothers, D. M. (1993). Stability and properties of double and triple helices: dramatic effects of RNA or DNA backbone composition. *Science*, **258**, 1463–1466.
- Sanger, W. (1984). In *Principles of Nucleic Acid Structure*, pp. 258–261, Springer-Verlag, New York.
- Schuster, P. (1995). How to search for RNA structures. Theoretical concepts in evolutionary biotechnology. *J. Biotech.* **41**, 239–257.
- Schuster, P., Fontana, W., Stadler, P. F. & Hofacker, I. L. (1994). From sequences to shapes and back. A case study in RNA secondary structures. *Proc. Roy. Soc. ser. B*, **255**, 279–284.
- Tsang, J. & Joyce, G. F. (1994). Evolutionary optimization of a DNA-cleaving ribozyme. *Biochemistry*, **33**, 5966–5973.
- Wang, A. H.-J., Fujii, S., van Boom, J. H., van der Marel, G. A., van Boeckel, S. A. A. & Rich, A. (1982). Molecular structure of r(GCC)d(TATACGC): a DNA-RNA hybrid helix joined to double helical DNA. *Nature*, **299**, 601–604.
- Zaug, A. J., Been, M. D. & Cech, T. R. (1986). The *Tetrahymena* ribozyme acts like an RNA restriction endonuclease. *Nature*, **324**, 429–433.
- Zaug, A. J. & Cech, T. R. (1986). The intervening sequence RNA of *Tetrahymena* is an enzyme. *Science*, **231**, 470–475.

Edited by D. E. Draper

(Received 1 May 1996; accepted 1 July 1996)