



1N-15
380 422
DATE OVERRIDE
16/P

TECHNICAL REPORT

R-97

CONSIDERATIONS AFFECTING SATELLITE AND SPACE PROBE RESEARCH WITH EMPHASIS ON THE "SCOUT" AS A LAUNCH VEHICLE

Compiled and edited by

Jack Posner

NASA Headquarters Staff

**ADVANCE
COPY**

NATIONAL AERONAUTICS AND SPACE ADMINISTRATION

WASHINGTON

1961

[Extremely faint and illegible text covering the majority of the page, likely bleed-through from the reverse side.]

2025 RELEASE UNDER E.O. 14176

NATIONAL AERONAUTICS AND SPACE ADMINISTRATION

TECHNICAL REPORT R-97

CONSIDERATIONS AFFECTING SATELLITE
AND SPACE PROBE RESEARCH WITH
EMPHASIS ON THE "SCOUT" AS
A LAUNCH VEHICLE

Compiled and edited by
Jack Posner
NASA Headquarters Staff

ABSTRACT

This report reviews a number of the factors which influence space flight experiments. Included are discussions of payload considerations, payload design and packaging, environmental tests, launch facilities, tracking and telemetry requirements, data acquisition, processing and analysis procedures, communication of information, and project management. Particular emphasis is placed on the "Scout" as a launching vehicle. The document includes a description of the geometry of the "Scout" as well as its flight capabilities and limitations. Although oriented toward the "Scout" vehicle and its payload capabilities, the information presented is sufficiently general to be equally applicable to most space vehicle systems.



CONSIDERATIONS AFFECTING SATELLITE AND SPACE PROBE RESEARCH WITH EMPHASIS ON THE "SCOUT" AS A LAUNCH VEHICLE

Compiled and edited by

Jack Posner

NASA Headquarters Staff

PREFACE

The Act of Congress which established the National Aeronautics and Space Administration (NASA) includes, in its statement of objectives the following: "(7) Cooperation by the United States with other nations and groups of nations in work done pursuant to this Act and in the peaceful application of the results thereof;" In keeping with this change, NASA has developed a space science program on a broad basis including international cooperative efforts. To name but a few, the United States has or is negotiating agreements or understandings with such countries as Great Britain, Canada, and Australia, and participates in such groups as committees of the United Nations and the Committee on Space Research (COSPAR).

This document has been prepared to serve as a guide and aid for scientists and engineers of all countries who are interested in satellite and space research. It should serve those directly active in the conduct, preparation or planning of satellite experiments, as well as those in related fields who wish information on the design of apparatus or on the vehicles used for launching scientific equipment into satellite or space probe trajectories. Included in this document are limited discussions of the facilities, supporting services, and division of responsibilities required in executing a scientific experimental study in space. Particular emphasis is placed on the "Scout" as a launching vehicle; therefore a description of the geometry and capabilities of that vehicle is included. Requests for additional information should be addressed to:

Director,
Office of Space Flight Programs
NASA Headquarters
1520 H Street, N. W.
Washington 25, D. C.
U. S. A.

This report is offered in recognition of the fact that the success of so complex an enterprise as the launching of a satellite or a deep space probe, its preliminaries, and its follow-ups, is directly related to the degree of cooperation and understanding achieved. The value of this effort is particularly enhanced by the opportunity it offers to the scientists and engineers of many nations to demonstrate to their people the progress which can be achieved through international good will and collaboration.

CONTENTS

Preface.....	i
CHAPTER 1 - INTRODUCTION.....	1
CHAPTER 2 - THE SCOUT VEHICLE	3
History and Background	3
Arrangement of the Vehicle.....	3
Structure and Materials.....	4
Control System and Autopilot.....	4
Payload Compartment	10
Trajectory and Performance Characteristics	12
Destruct System.....	17
References.....	24
CHAPTER 3 - PAYLOAD CONSIDERATIONS	25
Scope of the Problem	25
Environment	25
Stabilization and Design	28
Weight Limitations.....	29
References	29
CHAPTER 4 - PAYLOAD DESIGN AND PACKAGING.....	30
Electronics	30
Power Supplies.....	41
Mechanical Structure	46
Materials.....	46
Temperature Control	48
References.....	53
CHAPTER 5 - ENVIRONMENTAL TESTS	55
Flight Acceptance and Design Approval Tests.....	55
Extent of Tests.....	56
Sounding Rockets for Testing Satellite Equipment	61
Test Facilities	63
Summary	69
References.....	69

CONTENTS (Cont.)

CHAPTER 6 - LAUNCHING	70
Scout Launching Tower	70
Flight Test Responsibilities.....	72
Launch Facilities	72
CHAPTER 7 - TRACKING	76
Methods	77
Tracking Facilities	82
Orbit Determination	91
References.....	91
CHAPTER 8 - TELEMETRY.....	93
Methods	93
Airborne Telemetry Systems	104
Receiving Facilities.....	109
References.....	114
CHAPTER 9 - DATA ACQUISITION, PROCESSING, AND ANALYSIS	115
Acquisition	115
Processing	116
Computing Facilities.....	116
Analysis.....	117
CHAPTER 10 - COMMUNICATIONS	118
CHAPTER 11 - PROJECT MANAGEMENT	121
Planning the Experiment.....	121
Constraints on the Launching System.....	122
Preliminary Discussions	123
High-Altitude Rocket Tests	124
Assembly and Checkout	124
Scheduled Commitments.....	125
Prelaunch Field Operations.....	126
Quantity of Data	128
Access to Data	128

CONTENTS (Cont.)

SUMMARY	130
ACKNOWLEDGMENTS	130
BIBLIOGRAPHY	132
APPENDIX A - PRELIMINARY ENVIRONMENTAL TEST SPECIFICATIONS FOR SCOUT PAYLOADS	140
Thermal Vacuum Test	140
Vibration Tests	142
Acceleration and Spin	145

CHAPTER 1

INTRODUCTION

The artificial earth satellite and the deep space probe are very powerful tools for scientific research. The effectiveness of these tools depends greatly upon the scientific competence and original ideas brought to bear upon their use. This competence and these ideas must necessarily come from the scientific community, which must be aware of the many problems and interrelationships associated with space research. Since the scientific community is by its very nature international, it is desirable that space science programs also be international in character.

Various groups have participated in the design of scientific satellite and space probe instrumentation during the International Geophysical Year and its succeeding space science program. This has resulted in a rather extensive family of instrumentation system elements produced specifically for space research. These devices have undergone numerous tests in simulated space environments and have proven their merit in actual space operations. The scientist considering a space research program will find available a wide range of system elements with utility far beyond their initial specific functions, and an ever growing list of devices which may meet present needs either directly or with minor modifications. However, because of the extensive work currently in progress, any listing of available equipment would quickly become obsolete. Many persons are closely following the development of space technology in its broad aspects. These persons can render invaluable assistance in obtaining information and/or flight hardware, and it is assumed that full advantage will be taken of this knowledge and skill.

The advent of space research has necessitated new concepts in equipment design philosophy which have brought about many new techniques. Requirements for long functional lifetimes in orbiting objects with no possibility of maintenance have placed a new emphasis on system reliability. Weight limitations and thermal problems have placed a premium upon techniques for performing flight functions with minimum operating power requirements. In general, weight limitations will be much more critical than physical dimensions. Space environmental conditions, such as vacuum, temperature, and zero gravity conditions and high radiation fields, have also influenced equipment design. While catastrophic collisions cannot be ruled out, meteors do not seem to pose a major problem. Many satellites and deep space probes may present some relaxation in mechanical requirements over equivalent sounding rocket experiments, since in the former,

equipment must survive accelerations and vibration during powered flight but will not usually be required to maintain functional integrity under those conditions.

Careful consideration must be given to compatibility of all elements of the instrumentation system. Large, complex flight packages will be particularly troublesome in this respect. For example, the stray fields of magnets associated with a mass spectrometer would destroy the effectiveness of any attempts to measure small magnetic fields; and gases which might evolve during the charge or discharge of chemical batteries could create local atmospheres that would negate attempts to study gas composition. Different experimenters who share a common payload must maintain close liaison with each other and with the systems design group to insure the effectiveness of their efforts.

The material presented here includes a brief review of factors that would influence the preparation of experiments. In addition a review is given of the supporting facilities which, it appears at present, will be available. Although reference is made throughout this paper to various systems such as Explorer, Pioneer, and Vanguard, it has not been possible to review all of them in detail. It has been decided to direct the emphasis toward the equipment, systems, and facilities that relate to the Scout vehicle and its payload capabilities, and at the same time to draw on experiences with other vehicles as appropriate. Accordingly, some of the material contained herein has been extracted from the references that are cited during the discussion.

CHAPTER 2

THE SCOUT VEHICLE

HISTORY AND BACKGROUND

The Scout vehicle was originally conceived by the Pilotless Aircraft Research Division (PARAD) of the Langley Research Center of the National Aeronautics and Space Administration. The vehicle was visualized as a logical extension of the PARAD family of solid-propellant research rockets which have been developed over the past several years.

The emphasis in the design concept was simplicity, which should logically lead to high reliability and, hopefully, to economy. The basic premise for the attainment of these objectives was that the propulsion units be solid-propellant rocket motors. A second important principle was that both hardware and techniques be, insofar as possible, "off-the-shelf" (proven items, or items readily attainable within the state of the art and readily proven reliable). Design studies initiated at PARAD indicated that a high-performance vehicle consisting of four solid-propellant stages could be designed to have (1) orbital capability with payloads up to 150 pounds, (2) a very-high-altitude probe capability with a useful payload, and (3) a capability to perform aerodynamic research experiments such as high speed reentry tests. Contracts were awarded late in 1958 and early in 1959 for motor procurement, for airframe construction and autopilot, and for control components. The first earth orbital flight employing the Scout as a launching vehicle was achieved on February 16, 1961.

Since the detailed design of Scout is constantly undergoing change, it cannot at this time be considered final; therefore the geometry, weights, and performance data given herein for the Scout are preliminary and subject to revision. They can, however, be considered reasonably realistic. A preliminary overall description of the geometry and concept of the Scout can be found in Reference 1 at the end of this chapter.

ARRANGEMENT OF THE VEHICLE

The Scout is a four-stage solid-propellant rocket system. The motors are arranged in a tandem configuration with transition sections between stages to tie the structure together and to provide space for instrumentation and controls. Each stage consists of a

single solid-propellant motor and nozzle. The complete configuration is about 21.6 meters (71 feet) long. The take-off weight (or launch weight) is about 16,540 kilograms (36,425 pounds). The diameter of the first stage is 101.6 centimeters (40.0 inches) exclusive of fins. The wedge fins have a total span of about 290 centimeters (114 inches). A diagram of the vehicle is shown in Figure 1, and a photograph of the vehicle and the "zero-length" launcher is shown in Figure 2 with the vehicle in the assembled position. The vehicle is shown in firing position on the launcher in Figure 3. The principal characteristics of the various stages of Scout are given in Table 1.

STRUCTURE AND MATERIALS

The motor cases for stages 1 and 2 are fabricated from steel. The last two stages have motor cases constructed from laminated glass cloth impregnated with plastic resin. The rocket motor cases and nozzles serve as the basic structure, the motors being fitted together by appropriate transition sections. The third- and fourth-stage motors are protected from aerodynamic heating by jettisonable covers fabricated from steel and plastic. An external conduit houses the necessary interstage wiring. Interstage transitions between the lower stages are faired over by glass-cloth plastic-resin laminates. The fins are fabricated from steel and attach to a steel and aluminum housing over the first-stage nozzle.

CONTROL SYSTEM AND AUTOPILOT

The Scout is aerodynamically stable in the take-off configuration. After separation of the first stage, all succeeding configurations of the remaining stages are aerodynamically *unstable*; significant unstable moments, however, are imposed only during second-stage burning since succeeding stages operate in near-vacuum conditions.

Even though the first stage is stable, considerations of possible thrust and aerodynamic misalignments and winds make some control mandatory. Aerodynamic controls are placed on the tips of the fins. Since these controls are ineffective for several seconds after launch, jet vanes are required for control during this period. These vanes remain in operation throughout the flight, as their use offers some advantages in overcoming thrust misalignments even when the tip controls become effective. After first-stage burnout and prior to second-stage ignition, only the tip controls are effective. The second and third stages are controlled by nitrogen-pressurized hydrogen peroxide jets mounted in the nozzle areas of the respective stage motors. The fourth stage is not controlled, but is spin-stabilized by firing spin motors just prior to fourth stage ignition; the payload, attached to the fourth stage, is also spun. The nominal spin rate is 160 rpm; however, the vehicle is designed to accommodate a range of inertias and spin rates.

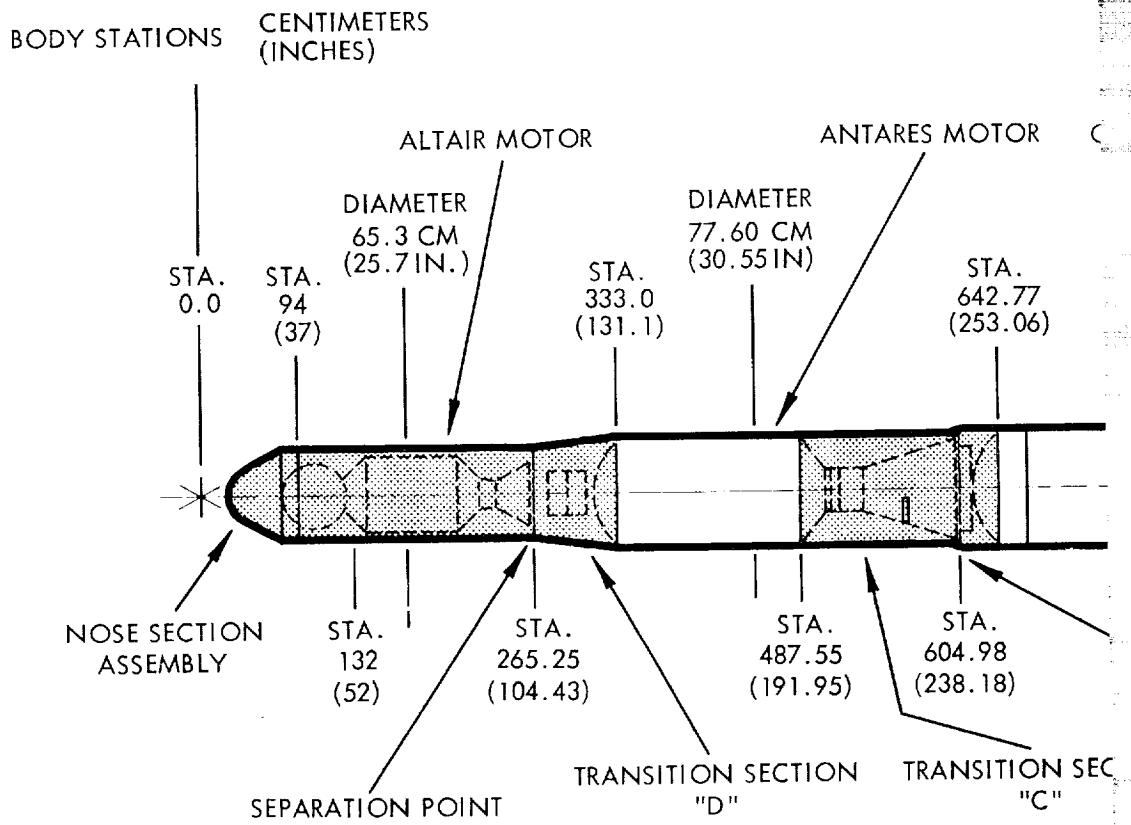

FOLDOUT FRAME 1

ASTOR MOTOR

TRANSITION SECTION "B"

DIAMETER
78.7 CM
(31.0 IN.)

DIAMETER
101.6 CM
(40.0 IN.)

STA.
1262
(496.9)

STA.
1130.4
(445.03)

STA.
1236.1
(486.66)

TION

SEPARATION POINT

SEPARATION POINT

ALC

FOLDOUT FRAME 2

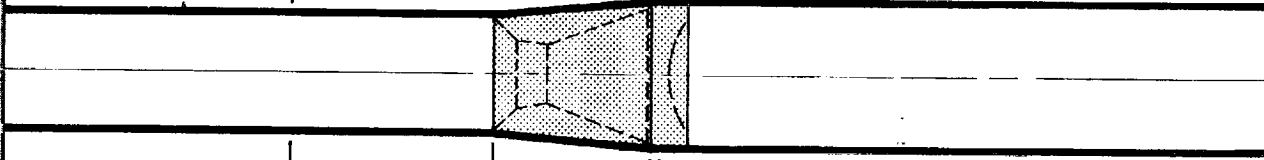

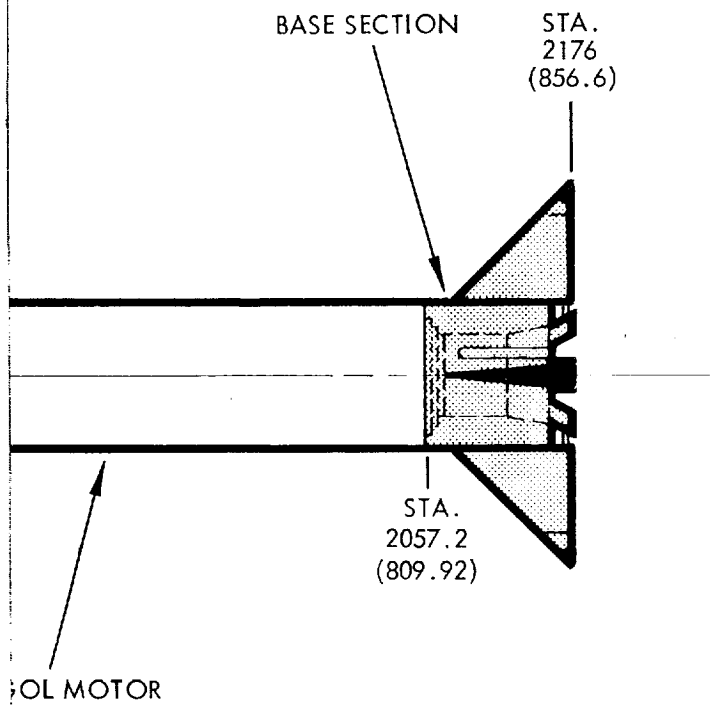

Figure 1 - General arrangement of the Scout vehicle

EOLDOUT FRAME 3

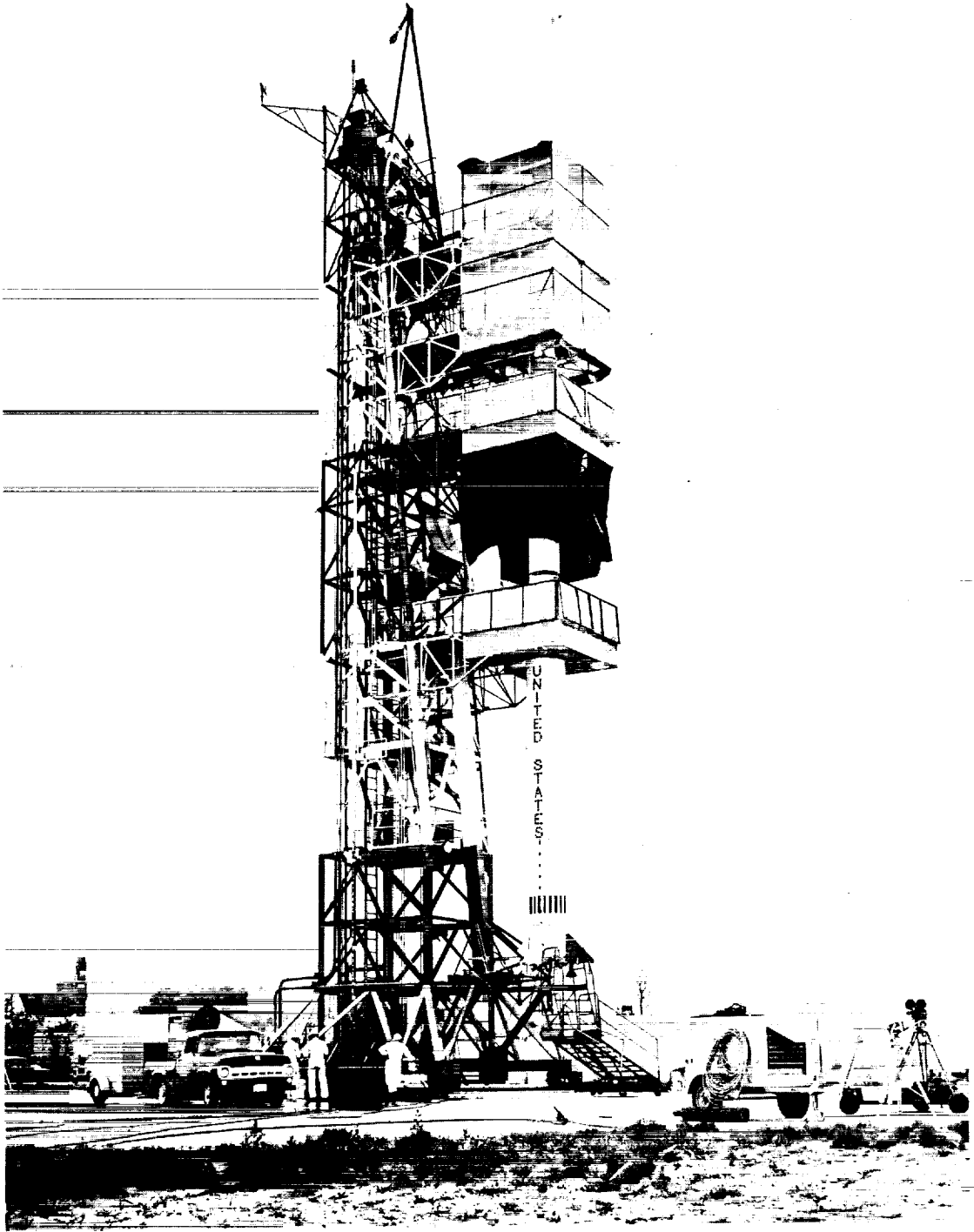

Figure 2 - Scout vehicle assembled on launcher

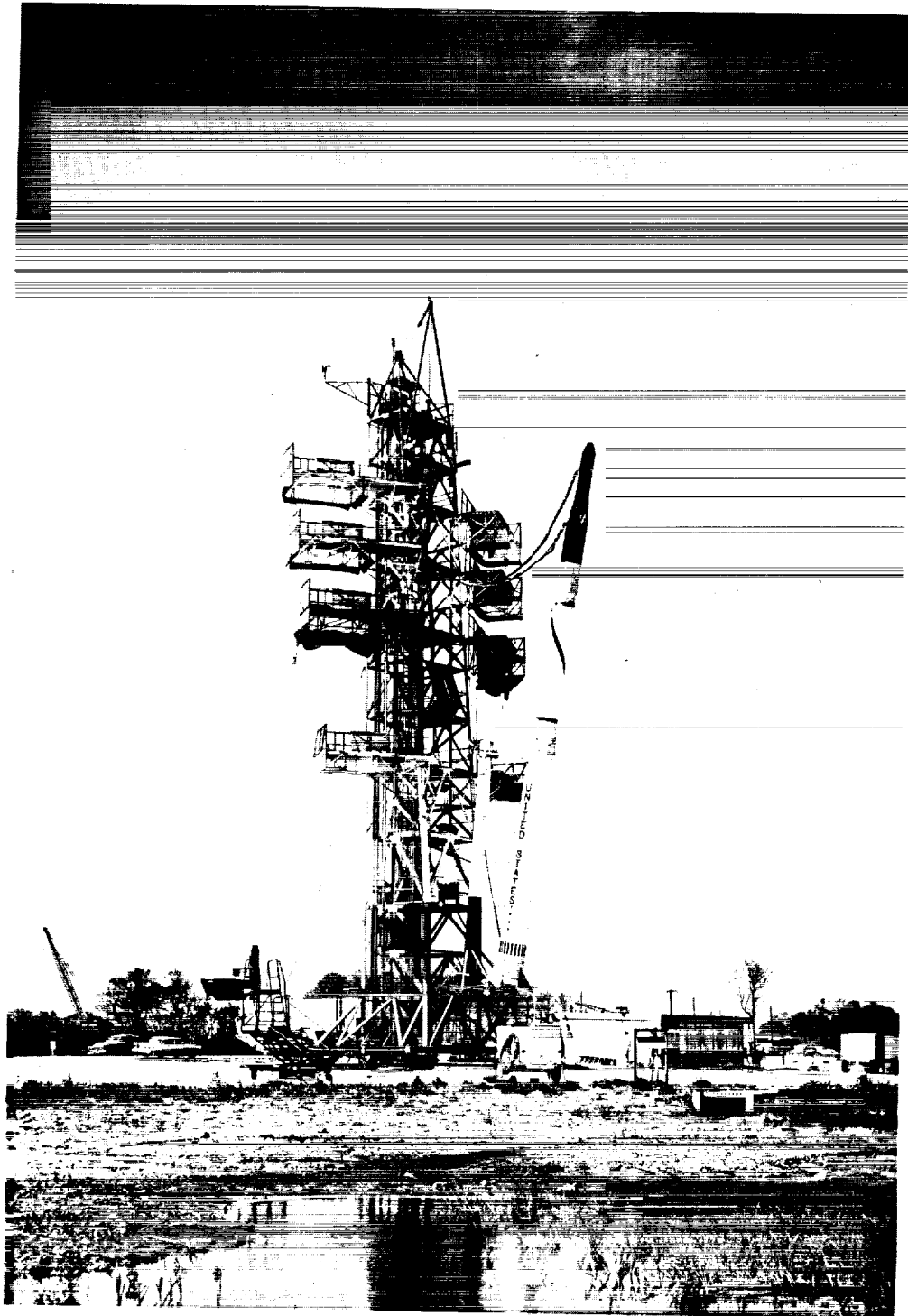

Figure 3 - Scout vehicle in launch position

Table 1

Characteristics of Various Stages of the Scout Vehicle

Motor Designation		Ignition Weight*	Propellant Weight	Thrust	Burning Time	Total Impulse	Specific Impulse	Diameter Including Outer Fairing	Length**
Stage	Manufacturer	(kg)	(kg)	(kg)	(sec)	(kg-sec)	(sec)	(cm)	(m)
1	Aerojet-Senior	10,710	8,660	46,760	40	1.86 x 10 ⁶	214	102	9.4
2	Thiokol-XM-33-20-4	4,360	3,310	28,150	27	0.740 x 10 ⁶	224	78.7	6.3
3	ABL-X-254	1,230	930	6,170	39	†0.240 x 10 ⁶	†255	77.6	3.4
4	ABL-X-248-A5	240	210	1,270	38	†0.0530 x 10 ⁶	†255	65.3	2.5

Motor Designation		Ignition Weight*	Propellant Weight	Thrust	Burning Time	Total Impulse	Specific Impulse	Diameter Including Outer Fairing	Length**
Stage	Manufacturer	(lbs)	(lbs)	(lbs)	(sec)	(lb-sec)	(sec)	(in.)	(ft)
1	Aerojet-Senior	23,600	19,080	103,000	40	4.100 x 10 ⁶	214	40.0	30.8
2	Thiokol-XM-33-20-4	9,600	7,300	62,000	27	1.634 x 10 ⁶	224	31.0	20.7
3	ABL-X-254	2,700	2,052	13,600	39	†0.524 x 10 ⁶	†255	30.55	11.1
4	ABL-X-248-A5	525	455	2,800	38	†0.116 x 10 ⁶	†255	25.7	8.3

*For 68-kg or 150-lb payload

**To separation point

† In vacuo

The autopilot is mounted on the forward end of the third stage and consists of a strapped-down, three-axis, gyro system. The system stabilizes the vehicle in roll and yaw and a pitch programmer commands the necessary pitch maneuvers to maintain the desired flight path. The initial values for the gyro references are the values at launch.

The pitch programmer produces a sequence of constant pitch-rate commands. The autopilot compares the command pitch attitude with the actual attitude and operates the controls so as to minimize the difference in angle. Airframe pitch-rate feedback is used, with the forward and feedback loop gains being varied after first-stage burnout. The tip and jet-vane controls are proportional and the peroxide jets are the on-off (bang-bang) variety with a small "dead zone." No provision currently is made for programming yaw and roll maneuvers, although such programming appears feasible through redesign of the autopilot.

The constant pitch command rates are chosen to approximate a controls locked, no wind, no thrust misalignment, near zero-lift trajectory; the control system is capable of flying the missile quite closely to this nominal trajectory in the presence of perturbing forces. Owing to structural limitations, the vehicle cannot be programmed to fly a trajectory much different from a nominal zero-lift trajectory; also, the maximum available control power imposes certain limitations on the permissible deviations from a zero-lift flight profile. This means that, in practice, vertical launchings can be used only for fairly high-perigee orbits; the exact lower limits have not yet been established. Structural limitations also impose a lower perigee limit to possible orbits; again the exact limit has not been established, but the minimum launch elevation angle is about 80 degrees, which produces a nominal 370-kilometer (200-nautical-mile) injection altitude. Lower injection altitudes are possible with special programming. Additional details of the autopilot and control system can be found in References 2 and 3.

PAYLOAD COMPARTMENT

The payload compartment of the Scout is mounted on the forward end of the fourth-stage rocket motor. In the present design, there is no provision for separating the payload section from the rocket motor, but such a provision can be made at the cost of additional complexity and weight. Experimenters' requirements will dictate whether or not separation is necessary. If payload separation is considered desirable, one of the several types of mechanisms which have been designed for separating the payload system from the expended last-stage rocket probably can be adapted. These devices generally impart a small initial separation velocity, usually obtained from springs. The mechanism may be actuated upon command from a ground station or by a preset timer on the last stage. An acceleration-sensing type of separation device is also available.

Keeping the system intact eliminates any possibility of collision between payload and rocket casing due to post-separation acceleration of the rocket by afterburning or outgassing. Optical studies of the orbits of expended solid-propellant rocket casings and their respective separated payloads have indicated considerable excess velocity on the part of the casings, showing that this is a significant problem. To provide a configuration which spins about the axis of its maximum moment of inertia, separation may be required to maintain payload spin about the initial spin axis where it is necessary for scanning purposes. Unseparated payloads present slightly greater uncertainties in their operating temperatures, owing to various degrees of shading of the payload surface by the rocket casing and to the thermal effects of the casing itself.

The payload compartment space available is approximately a cylinder 65.3 centimeters (25.7 inches) in diameter and 76 centimeters (30 inches) long. In addition, volume is available in the conical portion of the heat shield and between the shield and the side of the fourth-stage motor. The latter space is an annular volume about 127 centimeters (50 inches) long, with an inside diameter of approximately 51 centimeters (20 inches) and an outside diameter of 65.3 centimeters (25.7 inches). Other volumes and shapes are possible, but each would require detailed design considerations.

The compartment is designed so that there will be little heat input from aerodynamic heating during the launching sequence. Heat generated within the payload by the equipment must be dissipated by radiation through the outer shell of the payload compartment. Methods of thermal design for the payload are discussed in Chapter 4, page 48. Provision for air cooling the payload while the vehicle is on the launcher is provided in the design of the launcher. A study of the aerodynamic heating of the Scout vehicle is presented in Reference 4.

Portions of the vehicle nose cone and of the payload mounting brackets are constructed of ferromagnetic material. It would be possible, however, to construct these components from nonmagnetic materials. After nose-cone separation, only the payload mounting studs would be left as magnetic material, since the fourth-stage motor case is constructed from fiberglass and plastic resin. Requirements for nonmagnetic construction could, therefore, be met more simply if it were not necessary to remove all magnetic material prior to nose-cone ejection.

It should be noted that the payload compartment is designed for a nonrecoverable data system. Experiments requiring recovery would demand special design considerations to insure survival of the payload under the reentry and impact conditions and for such items as parachutes, flotation gear, radio beacons, chaff, dye-markers, etc.

Limited space may be available in the third stage to house small secondary payloads. Most of the space in this stage, however, is taken by the autopilot unit and

vehicle-performance telemetry system. In addition, it would be desirable in many cases to have some vehicle-performance instrumentation included as part of the fourth stage to aid in determining the conditions at the time of payload injection into orbit.

TRAJECTORY AND PERFORMANCE CHARACTERISTICS

The Scout vehicle is launched from a zero-length launcher and, as has been noted previously, must be programmed to fly a near zero-lift flight path. Control of the orbit characteristics is accomplished primarily by changing the launch elevation angle and the programmed pitch rates, although a small amount of control can be exerted by programming a small deviation from a zero-lift flight path (this, of course, is mandatory for launch at a 90-degree elevation angle) or by small changes in coasting time between stage firings. Launch azimuth is set in by rotation of the launch tower.

There are limitations to the allowable variations in the trajectory program. Launch elevation angles less than approximately 80 degrees cannot be used because of structural load limits. The second-stage rocket cannot be ignited below approximately 40,000 meters (130,000 feet), because of aerodynamic heating considerations and of control problems due to aerodynamic instability. The use of longer coasting times to permit firing at heights much above 40,000 meters (130,000 feet) result in performance degradation which could become intolerable.

The first stage remains attached to the remaining stages after burnout until the system coasts to 40,000 meters (130,000 feet); the vehicle is controlled during this coast by means of the aerodynamic tip controls on the fins. Stage separation occurs when the exhaust gases of the second stage collapse a coupling between the first and second stages. A similar arrangement separates the third stage from the second at third-stage ignition. The jettisonable covers over the third and fourth stages are ejected just prior to third-stage ignition. After third-stage burnout, both the third and fourth stages coast nearly to the apogee of the ascent trajectory. At this time the fourth stage and payload, which are mounted on a turntable on the head end of the third stage, are spun by small tangential spin rockets to a nominal rate of 160 rpm. After spin-up, the fourth stage blasts free of the third by the same means as that used in the previous stages. For a high-altitude probe, the fourth stage would probably be spun up and ignited just after third-stage burnout.

The orbital performance characteristics of the Scout vehicle are shown in Figures 4 and 5. The payload weights are considered to be the weight of instrumentation, instrumentation structure and attachments, and internal heat shield if required (that is, all weight carried ahead of the fourth-stage motor after ejection of external head shields and nose cone).

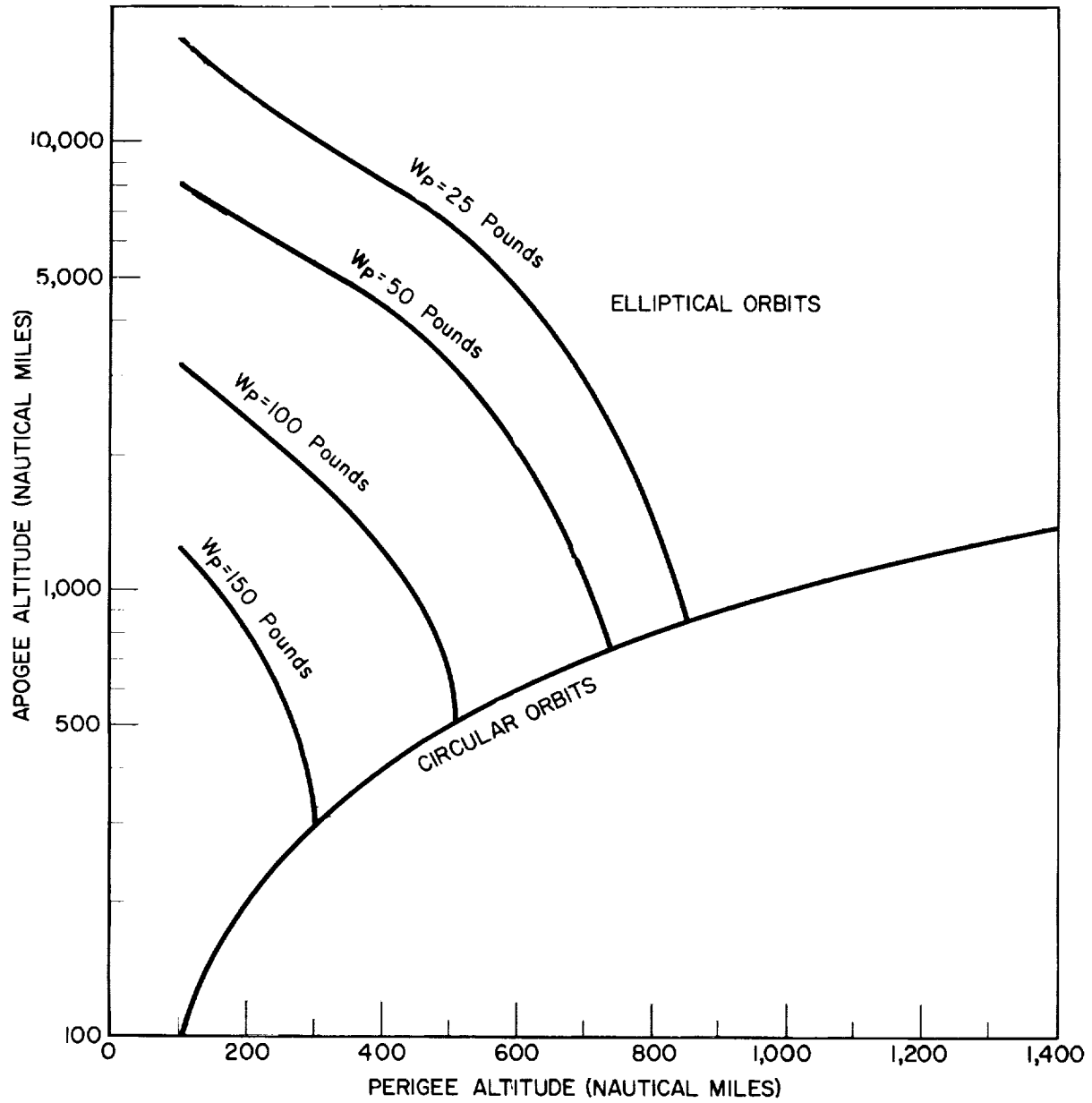

Figure 4A - Orbital mission capabilities for due east launch from Wallops Station
(plotted in english units)

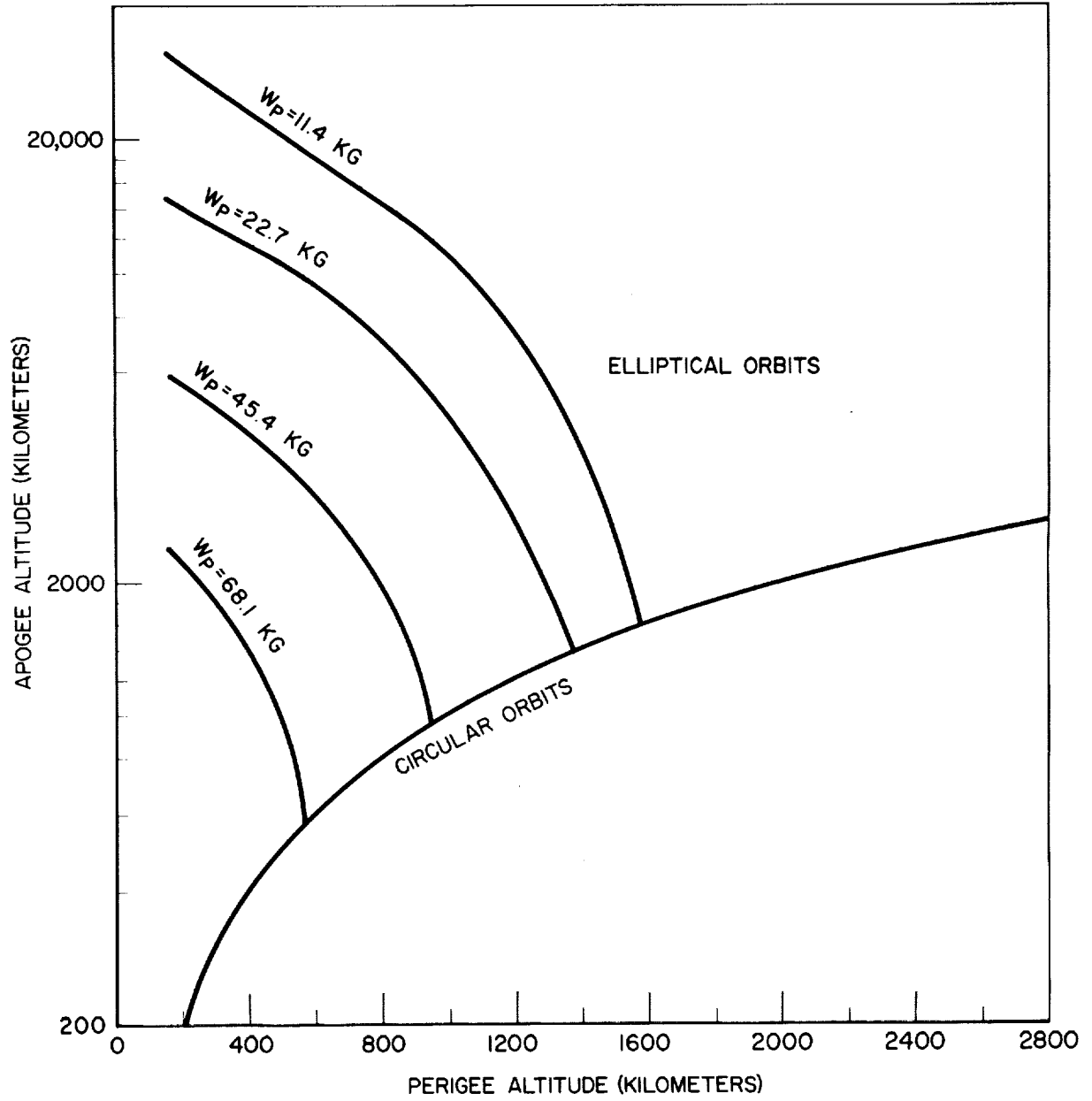

Figure 4B - Orbital mission capabilities for due east launch from Wallops Station (plotted in metric units)

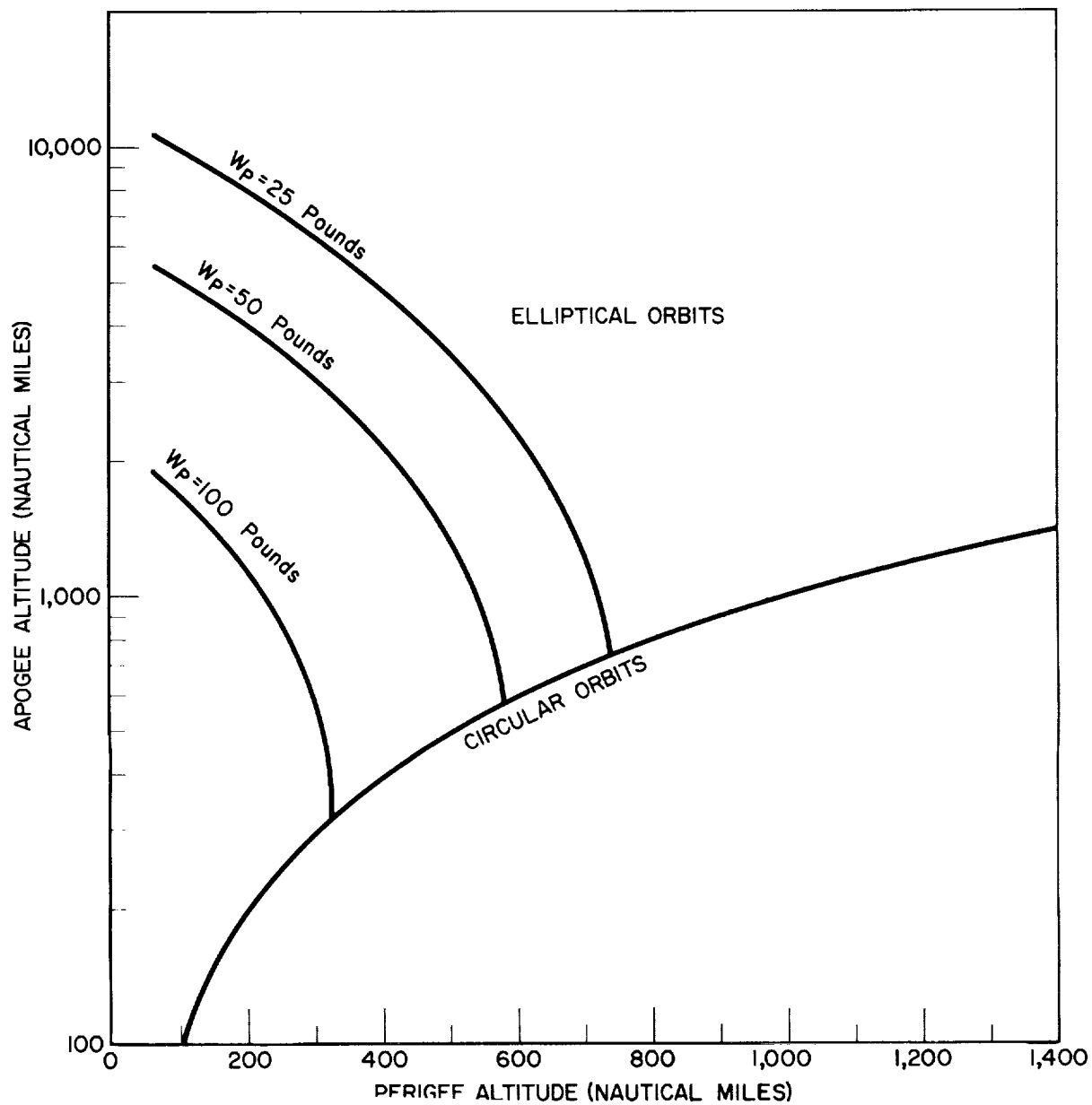

Figure 5A - Polar orbital mission capabilities for due south launch from Pacific Missile Range (plotted in english units)

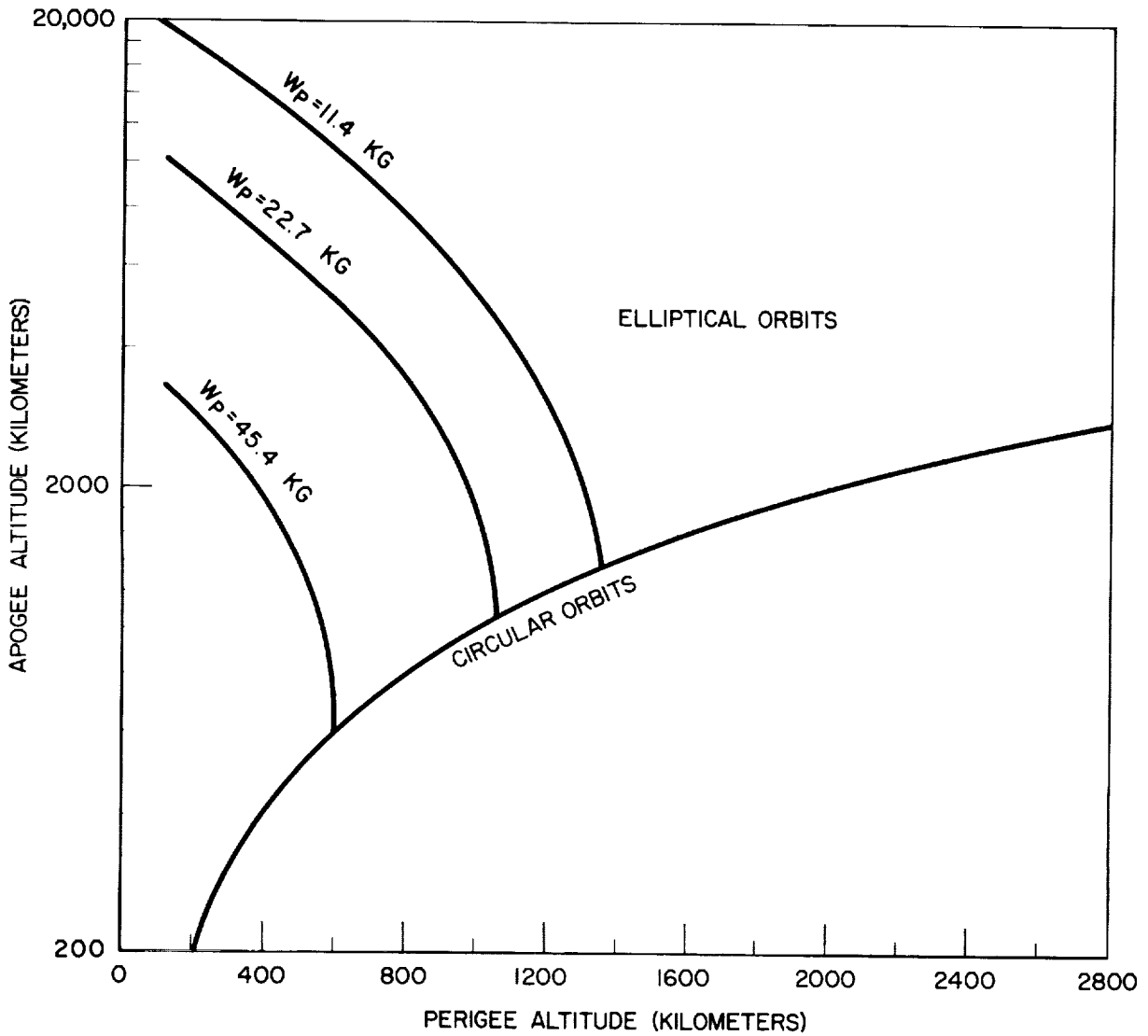

Figure 5B - Polar orbital mission capabilities for due south launch from Pacific Missile Range (plotted in metric units)

Figure 4 gives apogee and perigee performance for a firing eastward from a rotating earth at a latitude of about 37 degrees; Figure 5 gives apogee and perigee altitudes for nonrotating-earth trajectories (polar orbits). These figures present performance calculated for zero injection angle. Since no velocity control is provided in the Scout, it would seem wise to plan for excess velocity and an elliptical orbit rather than a circular orbit.

Apogee altitudes for probe type missions are shown in Figure 6. Figure 7 shows the zero "g" flight time these probes would produce. Safety regulations may rule out certain launch azimuths; range safety corridors are functions of the launch site.

Since the vehicle operates on a programmed attitude-control basis, there is no direct control over changes in velocity, altitude, range, or flight path due to such things as winds, thrust misalignment, or impulse variations. Errors due to root-mean-square sums of reasonable variations in those items are fairly small, however. An analysis has been made of the probability of variations in orbit performance characteristics based on assumptions of various errors or deviations in components or perturbing forces.

Figure 8 gives the variation of perigee and apogee altitudes for given values of the ratio of injection velocity to circular velocity (V_{inj}/V_C); the corresponding error curves are shown in Figure 9. Orbits for which $V_{inj}/V_C = 1.01$ to 1.02 (equivalent to eccentricities of $e = 0.02$ and 0.04 respectively) should be planned to give low probable errors in perigee altitudes, as is shown by the sharp drop in the error curve. The smaller perigee errors for vehicles programmed for slightly elliptical orbits are due to variations in the total impulses of the solid-propellant motors.

DESTRUCT SYSTEM

The firing of large rocket vehicles at most test ranges is subject to the requirement that a "destruct" system be aboard the vehicle so that, in the event of certain types of malfunction, the flight can be aborted and the vehicle disposed of with minimum hazard to life and property. Such a system is incorporated into the Scout design. It should be noted that the system used satisfies the safety requirements of one particular test range and may not be applicable to all such sites.

A destruct system is mounted on the third stage of the Scout. Destruction of the first three stages is accomplished by failing them as pressure vessels by splitting them longitudinally. The destruct signal also deactivates the fourth-stage ignition circuitry.

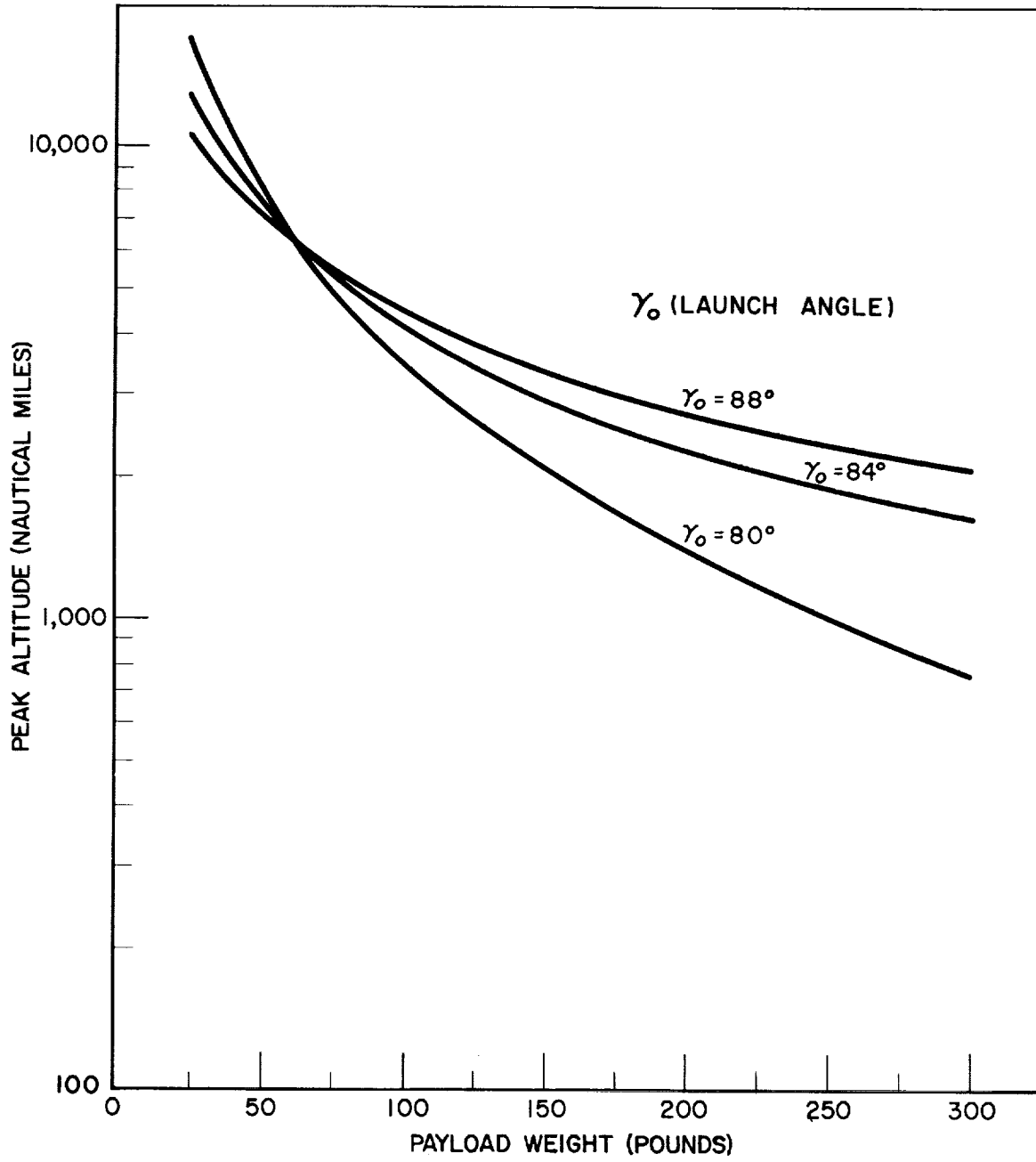

Figure 6A - Peak altitude as a function of payload weight for probe type trajectories launched due east from Wallops Station (plotted in english units)

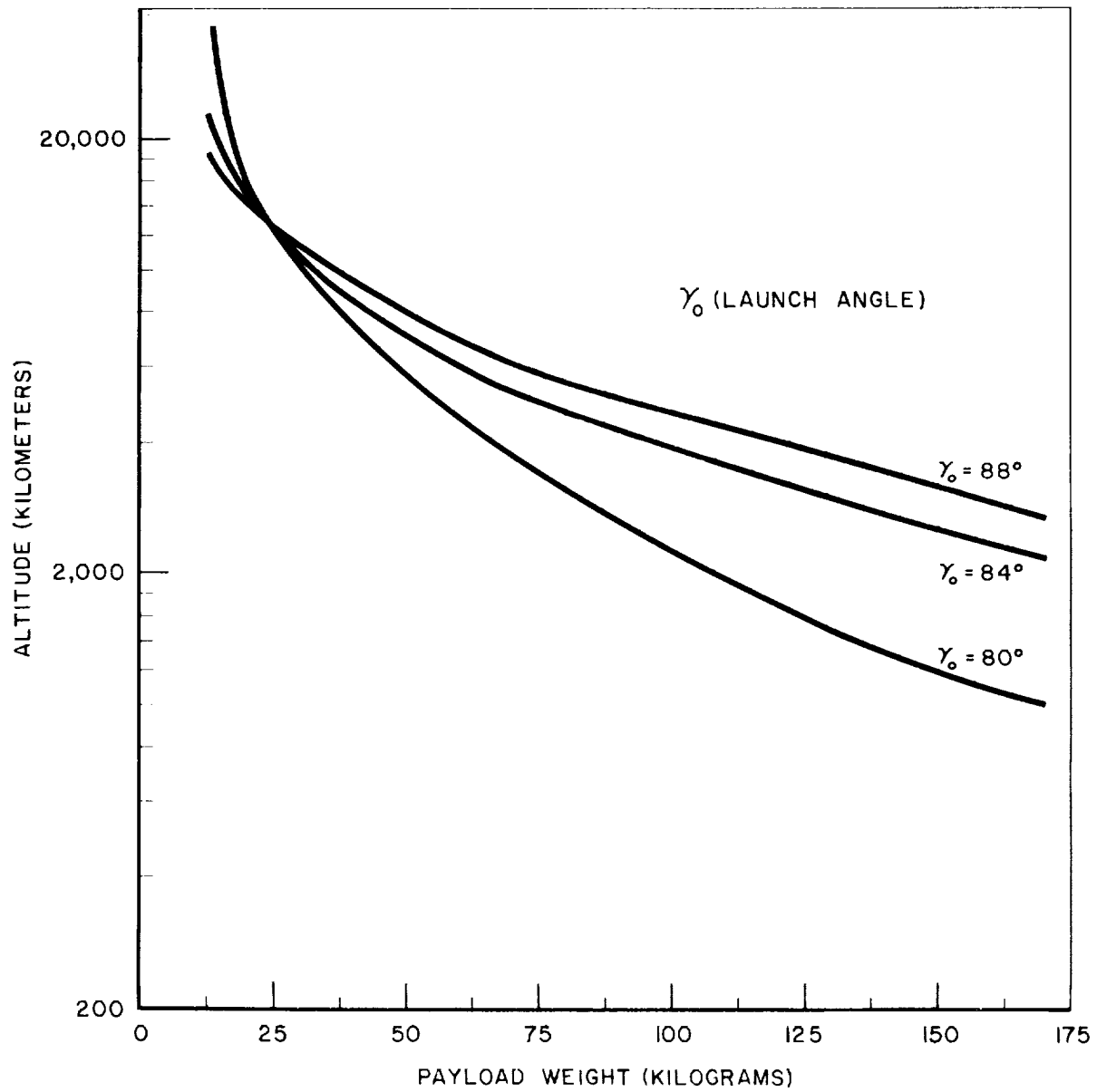

Figure 6B - Peak altitude as a function of payload weight for probe type trajectories launched due east from Wallops Station (plotted in metric units)

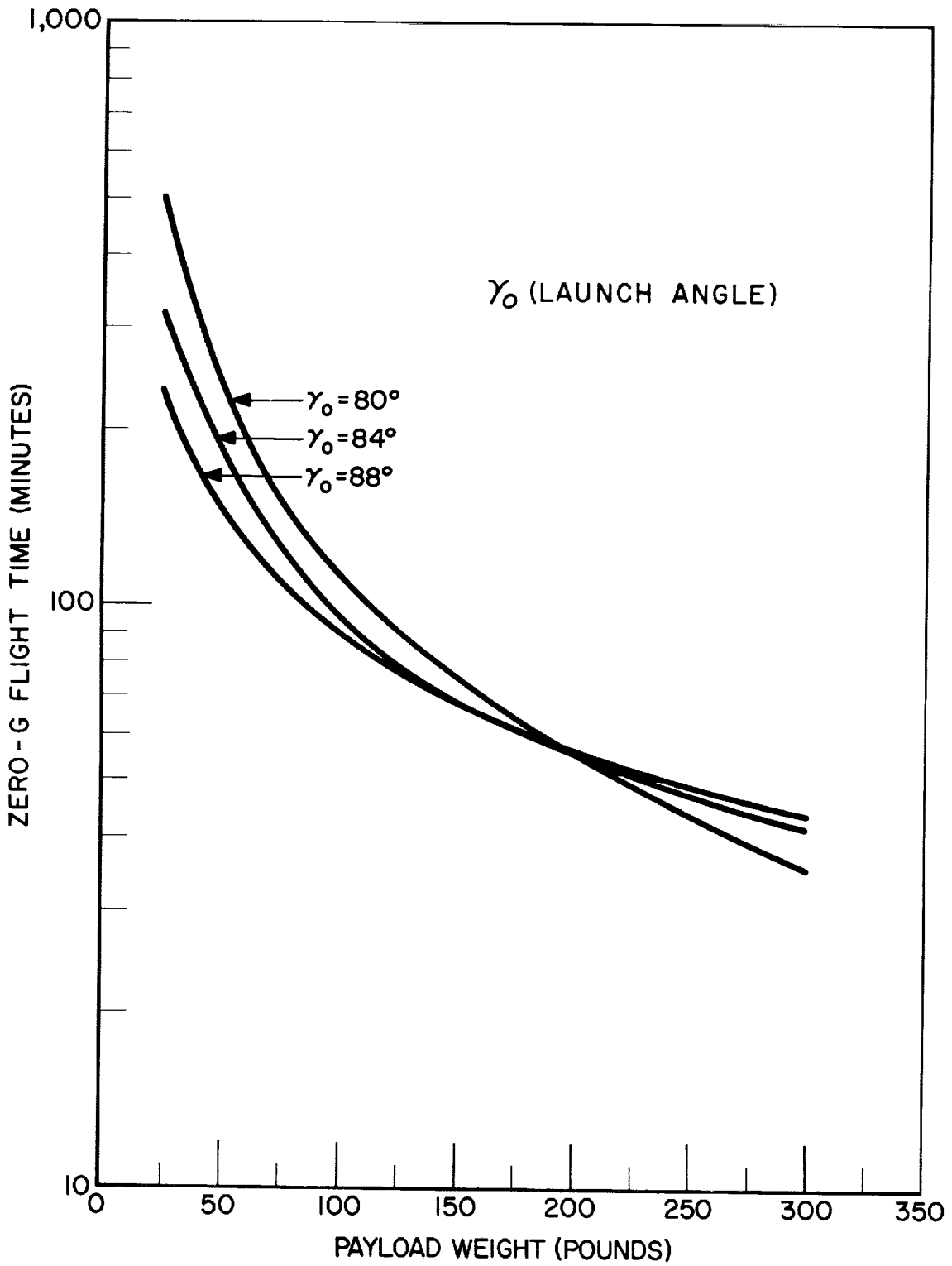

Figure 7A - Zero-g flight time as a function of payload weight for probe type launched due east from Wallops Station (plotted in english units)

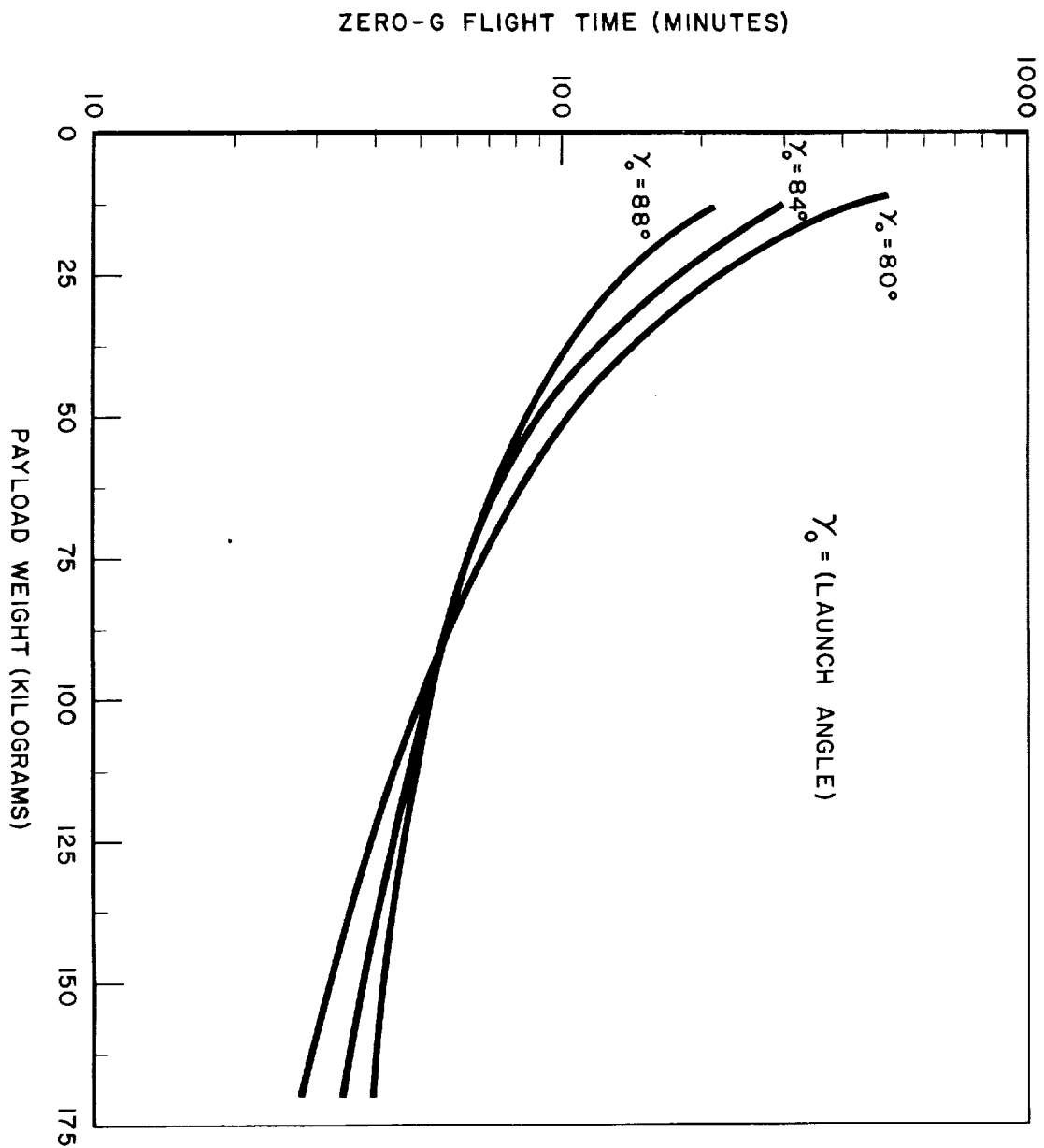
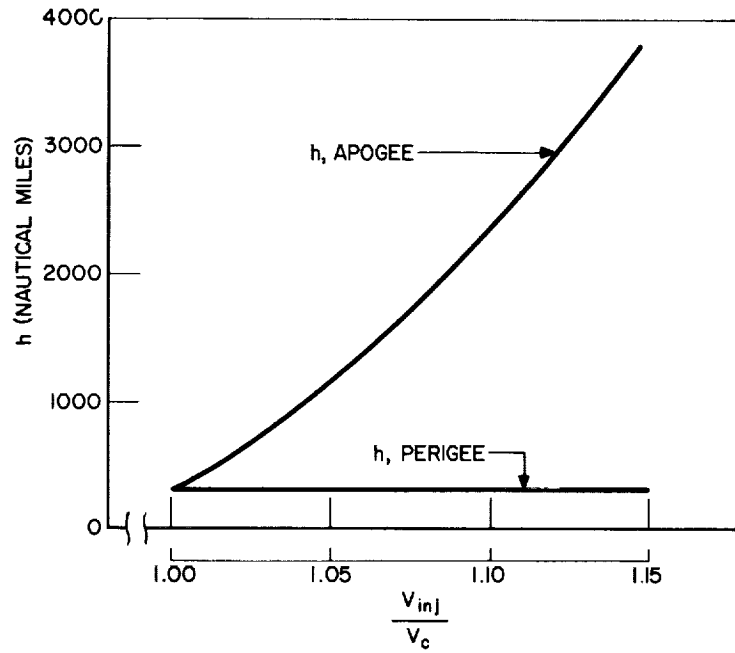
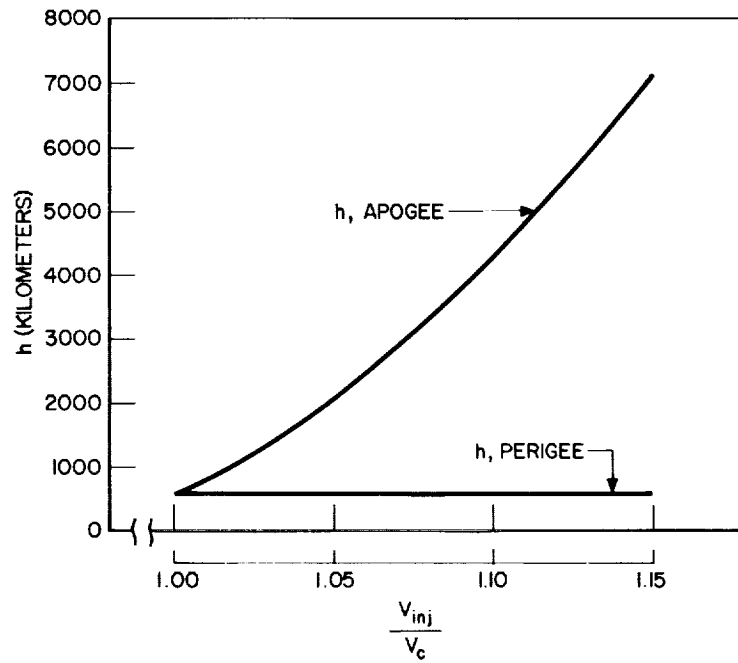

Figure 7B - Zero-g flight time as a function of payload weight for probe type launched due east from Wallops Station (plotted in metric units)



(a) plotted in english units



(b) plotted in metric units

Figure 8 - Effects of increased injection velocity on apogee and perigee altitudes

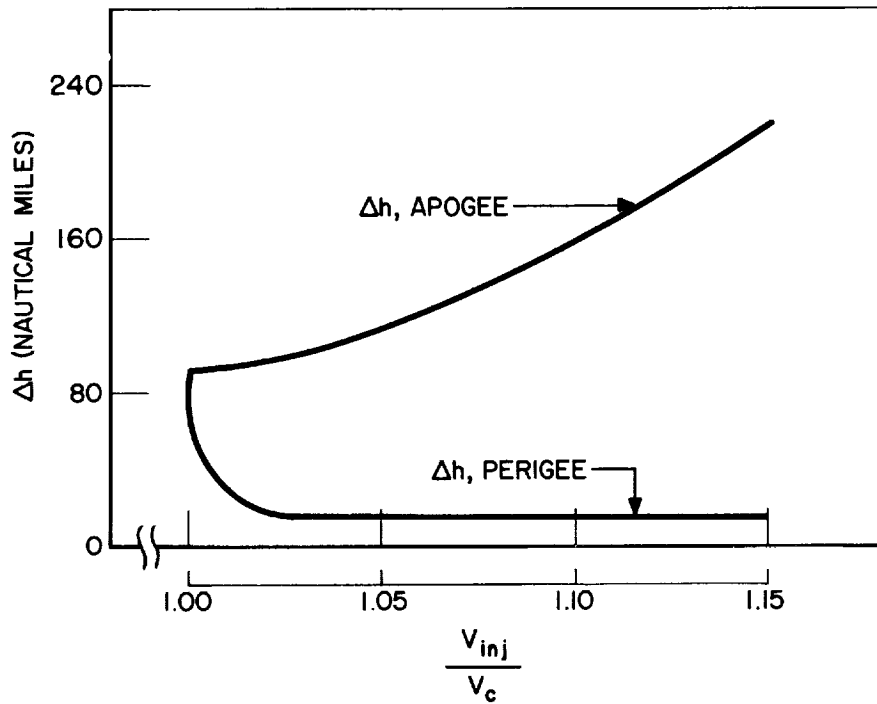

(a) plotted in english units

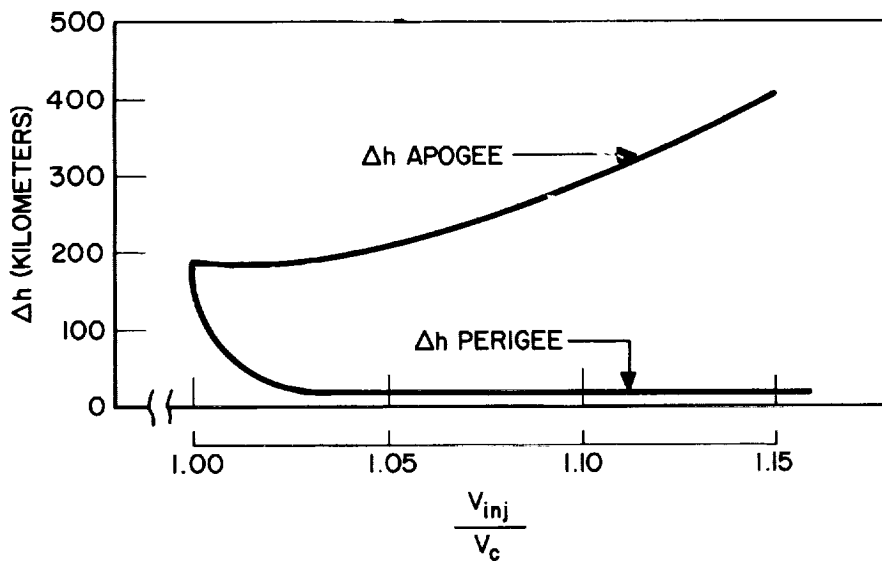

(b) plotted in metric units

Figure 9 - Effects of 2σ errors on a 300-nautical-mile (555-kilometer) circular orbit phase
 main caption at bottom of page

*REFERENCES**(Chapter 2)*

1. "Scout Manual," NASA Langley Research Center, Hampton, Virginia, April 25, 1960
(Not available for distribution)
2. Robins, Clarence A., Jr., "A Description of the Scout Guidance and Control System,"
NASA Langley Research Center, Hampton, Virginia, April 11, 1960 (Not available for
distribution)
3. "Procedure for Assembling the Scout Control System," NASA Langley Research
Center, Hampton, Virginia (Not available for distribution)
4. Speegle, Katherine C., "Ascent Aerodynamic Heating Predictions for the Scout Research
Vehicle," NASA Langley Research Center, Langley Field, Virginia, March 15, 1960
(Not available for distribution)

CHAPTER 3

PAYLOAD CONSIDERATIONS

SCOPE OF THE PROBLEM

There are so many areas requiring consideration in payload design and packaging that it would be virtually impossible to discuss them all in adequate detail here. It would be worthwhile, however, at least to mention some such areas in order to illustrate and emphasize the complexity of the space payload design problem. For example, in a composite experiment payload package, great care must be exercised to assure compatibility of the various components. The danger exists that a sensor will detect a signal emanating from the experimental equipment rather than from the space environment. In addition—to name but a few—there must be knowledge of such factors as the telemetry and tracking coverage required and available, structural requirements and limitations, the percentage of total payload weight that is available for scientific instrumentation, the spare parts and units required as a safety factor, the space environment itself, payload stabilization, and factors affecting weight limitations. The latter three factors are discussed in somewhat more detail in the following pages.

ENVIRONMENT

The most significant environmental information gained thus far from satellites and space probes can be inferred from the fact that they have performed satisfactorily. This implies that the present state of knowledge and techniques provides an adequate basis for planning a more detailed study of outer space. For example, the fact that the passive temperature-control techniques employed on both the Vanguard and the Explorers were as effective as had been predicted, indicates that there are no peculiar thermal properties of space. Critical environmental information telemetered back to earth from micro-meteorite experiments carried on the Explorers and the Sputniks indicates that structural damage from these particles is most unlikely, and that the erosion rates are small for metallic surfaces.

A satellite or space probe will be surrounded by fields of various kinds, but most of these are too weak to affect significantly any payload component except one specifically designed to be sensitive to a particular field. Thus, the presence of the gravitational

field is not even felt by the payload because the entire vehicle is in free fall. The weak electric fields which exist in space merely cause infinitesimal readjustments of charge on the metallic outer surface of the payload, and are not felt within the satellite or probe. The magnetic field between 185 and 1850 kilometers (100 and 1000 nautical miles) varies with altitude and magnetic latitude between approximately 0.57 and 0.15 gauss; these values are not significantly different from those found at the Earth's surface.

Grouped together under the term "radiation" are several types of fields, most of which are extremely weak in space. The solar electromagnetic radiation field has overwhelmingly more energy density than the other fields, and its chief effect is to warm the payload. The ultraviolet portion of the spectrum, by the photoelectric effect, causes the vehicle to have a small net electric charge, but this has no internal effect. The small amount of solar x-radiation which may penetrate to the interior will merely knock out a few electrons randomly.

Several types of charged-particle radiation fields exist in space. The primary cosmic radiation is a very penetrating corpuscular stream, but its energy flux is less than 6×10^{-3} erg/cm² per second (or 2×10^8 times less than the solar electromagnetic radiation flux), and only a fraction of this energy is deposited in the vehicle. The effect of the rays is ionization in the payload materials, the dose rate being probably less than 0.1 roentgen per day. Since a million roentgens are required to produce noticeable effects in most materials (excluding biological tissue and certain other hypersensitive substances), it is evident that the cosmic radiation will have no significant effect on the payload. However, it will provide an interesting subject for scientific investigation.

Charged-particle fluxes of solar origin also exist in the solar system, but their intensity, energy distributions, and temporal variations are very incompletely known at present, and the investigation of their properties will be one of the major space research programs of the next few years. When the sun is quiescent, these fluxes probably have negligible effects upon spacecraft. The particles have too low energies to penetrate the outer skin, and they merely contribute slightly to the heating of the surface and erode it away very slowly by the "sputtering" mechanism. The rate of sputtering cannot be accurately estimated, but it appears that it will not exceed 600 angstroms per year and is likely to be less than 15 angstroms per year.

Particle fluxes of much higher energy are emitted intermittently by the sun from chromospheric flares. The highest-energy protons in these streams, and perhaps also the highest-energy electrons, are able to penetrate into the spacecraft and produce significant effects. The protons are likely to be the most serious. Energies as high as 500 Mev (corresponding to a range of 20 cm or 8 inches in lead) have been observed, and still higher energies probably occur; but since the energy spectrum usually is very steep,

low energies contribute most of the flux. The ionization dose rate can be several thousand times that from the cosmic rays, a typical number for an intense flare being probably of the order of 1 roentgen per hour behind one gm/cm^2 of shielding. The flare of August 22, 1958 produced a flux at the earth of approximately 500 protons/ cm^2 per second above 30 Mev.

Still more intense charged-particle fluxes are encountered in the Van Allen radiation zones, which encircle the earth near the magnetic equatorial plane. These zones contain protons and electrons trapped in the geomagnetic field for long periods. According to current ideas the inner zone, almost certainly fed by the radioactive disintegration of so-called albedo neutrons knocked out of air atoms by incident cosmic-ray protons, contains proton fluxes as high as $10^4/\text{cm}^2$ per second above 40 Mev, and electron fluxes of $10^{10}/\text{cm}^2$ per second above 20 kev. Its approximate extent is from 1000 to 10,000 km (620 to 6200 miles) in altitude within 45 degrees of the geomagnetic equator. Proton energies are as high as several hundred Mev and electron energies as high as one Mev, although the preponderance of the flux is at much lower energies.

The outer Van Allen zone is a torus with a banana-shaped cross section, and its origin is the subject of a vigorous controversy at present. Its lower edge is considered to be approximately along a geomagnetic force line which intersects the equator near 10,000 km (6200 miles) altitude. Its upper edge (defined as the lowest point at which a radiation detector records only cosmic-ray background) varies between 8 and 15 earth radii from the geocenter, depending upon solar activity. Its ends dip down to below 500 km (310 miles) altitude near 60 degrees magnetic latitude, but the intensity is small (not over a few hundred particles/ cm^2 per second), and no trapped radiation is observed or expected near the poles. The intensity as well as the extent of the zone is highly variable. The maximum electron flux is not known, but is greater than $10^{11}/\text{cm}^2$ per second above 20 kev at 3 or 4 earth radii near the equator. Energies are mostly below 100 kev and practically all below 1 Mev (Reference 1). Protons have not been positively detected in the outer zone, but they probably have low energies if they exist.

It is not possible at present, because of uncertainties in the energy spectra, to quote accurately the ionization dosages encountered in the zones. The steepness of the spectra means that the dose rates vary rapidly with small changes in shielding. Rates above 10 roentgens per hour have been observed in the outer zone with an ionization chamber shielded by $0.14 \text{ gm}/\text{cm}^{-2}$. Although these radiation levels are high in comparison to human tolerance, exposure to the zones for moderate periods will have little effect on most spacecraft components. Both germanium and silicon transistors have been exposed to beta radiation of 100 roentgens per hour for as long as one week with no changes in parameters (Reference 2) or spurious signals. Since semiconductors are the components most likely to be affected by radiation, it appears that the only space probes

requiring special radiation protection will be those carrying people or specific radiation-sensitive equipment such as photographic emulsions.

The life of a photographic plate at such a dose rate would be relatively short. It appears that 4×10^8 protons/cm² with 25 Mev energy will perceptibly fog a Tri-x film, and ten times this dose will seriously affect its picture-taking capability. One gm/cm² of shielding allows about one day in the most intense portion of the inner zone, but only fairly modest increases in shielding are required to increase this time substantially.

In addition to the environmental data telemetered to Earth, those satellites already in orbit also have yielded, through the study of their orbits, improved estimates of the pressure in space. The density is about 10 times greater than the 1956 ARDC atmosphere; but this is not really significant for design purposes, since the pressures in space are several orders of magnitude lower than can be achieved in research laboratories on earth (Reference 3).

STABILIZATION AND DESIGN

In order to assure directional stability, the last-stage rocket and payload of the Scout will be spin stabilized. This is generally true for solid-propellant final stages. Both the rocket and the payload must be statically and dynamically balanced in order to minimize flight-path errors during last-stage burning. The degrees of balance required are functions of the mission as well as of vehicle characteristics. Every effort should be made to locate elements symmetrically about the spin axis to minimize the added weight required to balance the system. Good design practice and experience have shown that for symmetrical payloads the balance weights should not exceed 1/2 percent of the payload weight, and they should not exceed 3 percent for asymmetrical payloads.

When spin about some preferred axis is dictated by the experiment, an effort must be made to locate the payload components so as to provide the maximum moment of inertia about the desired spin axis. It may be desirable or necessary to reduce the initial spin rate to meet the scientific objective. Several systems have been used, but the most promising lightweight system currently considered is the so-called "yo-yo" devised by the Jet Propulsion Laboratory. When spin stabilization is no longer required, small weights attached to cables wound around the payload are released. Most (or all, or "more than all") of the initial rotational momentum of the system is transferred to outward acceleration of the weights. This momentum is discarded by releasing the cables when they reach their full extension. It has been shown, both theoretically and experimentally, that through proper selection of the weights and cable lengths, the spin rate of the payload can be reduced to any desired value, including negative values. This system was used successfully on Pioneer IV.

WEIGHT LIMITATIONS

Payload weight limitations will be determined by the vehicle capability and the orbit or trajectory requirements of the mission. The data given in Chapters 2, 3, and 4 can be used as a guide. Weight penalties will be particularly high where recovery or stabilized platforms are required by the mission. Research and development programs are underway to provide stabilized platforms and recovery of payload packages from either earth orbits or relatively high-altitude space-probe firings. Although stabilized platforms will not be available to the scientific experimenter preparing Scout payloads, this technique offers many intriguing possibilities for future operations.

REFERENCES

(Chapter 3)

1. Van Allen, J. A., "Radiation Belts Around the Earth," *Scientific American* 200(3): 39-47, March 1959
2. Pilkington, W. C., "Effects of Irradiation on Transistors," Jet Propulsion Laboratory External Publication No. 366, Pasadena, California, April 1, 1957
3. Manning, E. and Dubin, M., "Satellite Micrometeorite Measurements," IGY Satellite Report Series, No. 3, May 1, 1958, IGY World Data Center A, Rockets and Satellites, National Academy of Sciences, Washington 25, D. C., pp. 25-30

CHAPTER 4

PAYLOAD DESIGN AND PACKAGING

ELECTRONICS

Telemetry Encoders

In rare instances, such as in the application of the proton precession magnetometer, the scientific sensor may be used to modulate the radio subcarrier directly. More common however, is the use of a telemetry encoder to generate a modulating signal that incorporates the outputs of many sensing elements. Several telemetry encoder systems have been used for space operations; some are described in Chapter 8. These have included a digital system (as in Explorer VI, 1959 Delta); families of subcarrier oscillators used either directly or with commutation to permit several information channels on one oscillator (as in Explorer VII, 1959 Iota); and the tone-burst system produced specifically for space use (as in Vanguard III, 1959 Eta).

A digital telemetry unit developed by the Space Technology Laboratories, Los Angeles, California and carried aboard Explorer VI (1959 Delta) is shown in Figures 10 and 11. This "Telebit" system accepts both analog and digital inputs from various experiments. The converted information at its output appears as a binary-coded subcarrier (1024 cps), which then phase modulates the signal of the 5-watt transmitter. The following discussion of the system was taken largely from Reference 1.

The binary output of the Telebit system occurs at a synchronous rate and is composed of repeating sets of frames of words; for Explorer VI, 11 words per frame were used. One word of each frame is used as a frame sync and is read out as all zeros, while the balance of the words are coded with the digital representation of the input information. Each word contains 12 pulses. The first two pulses (for information words) are always coded the same (zero, one) and define the start of a word; that is, these two pulses provide a word sync. The other 10 pulses may have any combination of binary values to represent a number from 0 to 1023.

Provision is made for transmitting information at 1, 8, or 64 pulses per second. This flexibility of information rate will find its greatest usefulness during the transit of interplanetary distances, where large changes in range are encountered. At 88 million

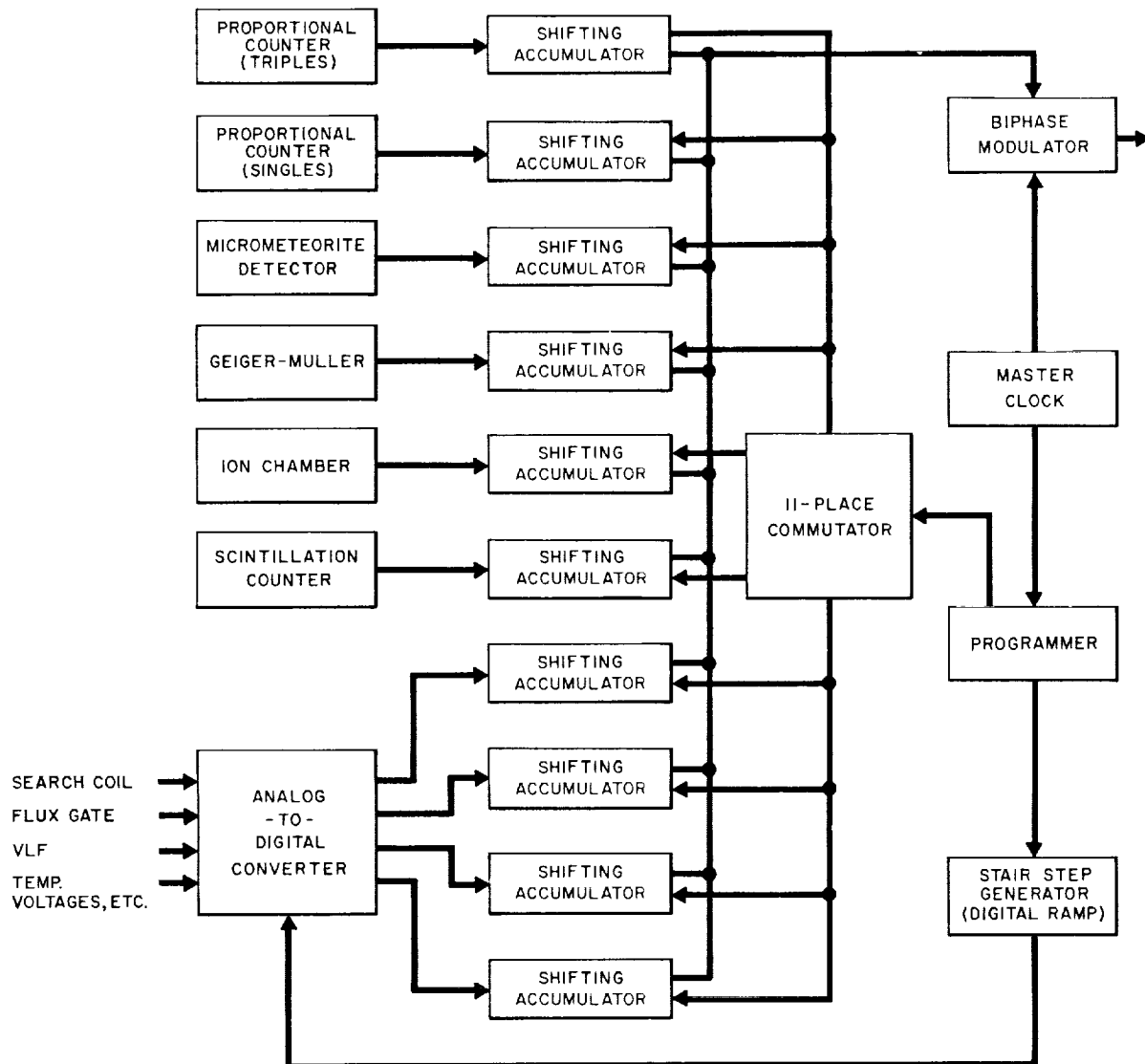

Figure 10 - Block diagram of Telebit system

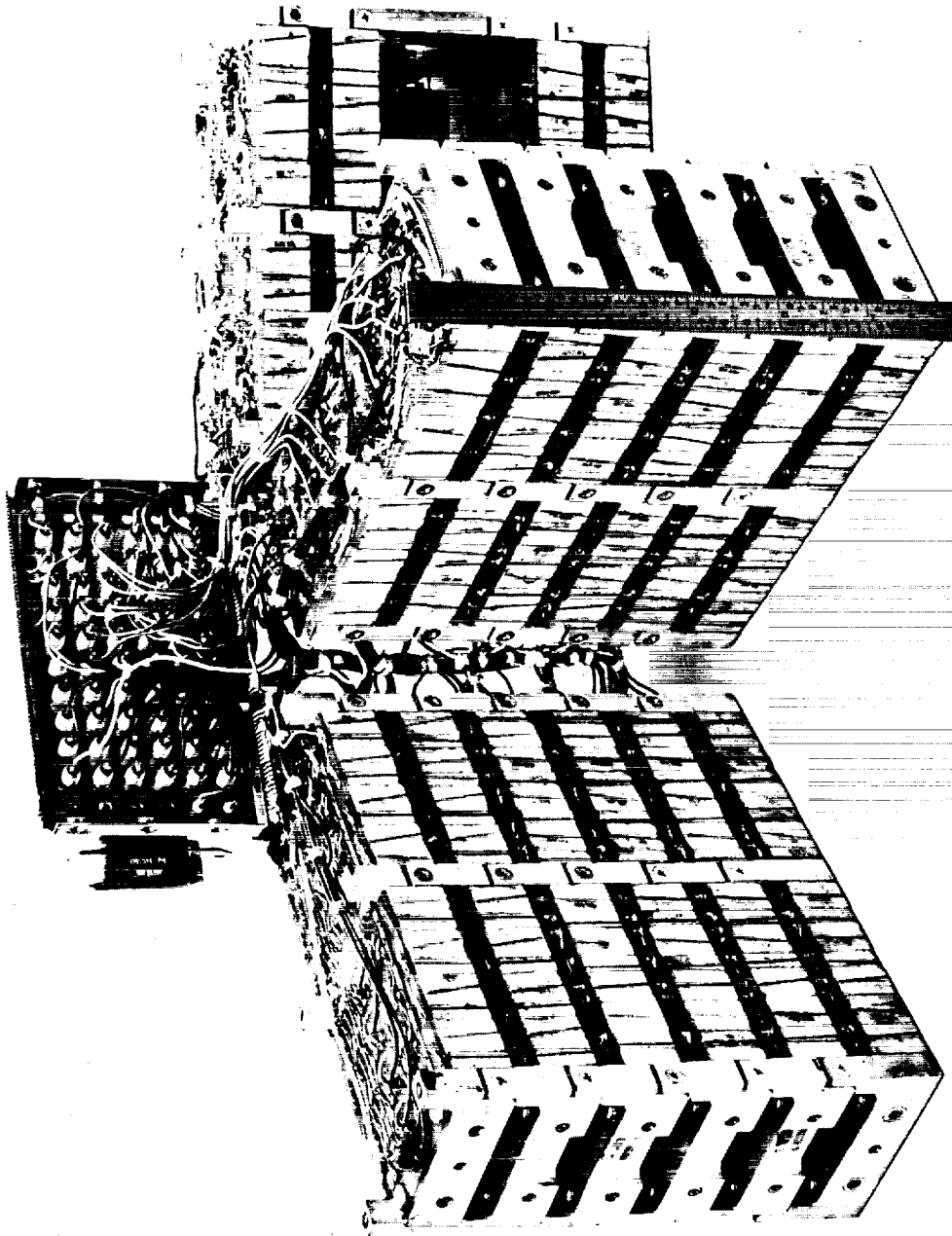

Figure 11 - The Telebit system

kilometers (55 million miles) with 150 watts, information can be conveyed at only 1 pulse per second, while at less than 800,000 kilometers (500,000 miles) 5 watts are sufficient to transmit at 64 pulses per second.

A 12-bit combination binary counter and shift register, referred to as a shifting accumulator, is provided for each word. Pulses from a digital-type experiment are applied directly to the counting input of a shifting accumulator, while an analog input is applied to an analog-to-digital converter whose output is then applied to a shifting accumulator. An electronic commutator, running synchronously at the word rate, gates 12 shift pulses to each shifting accumulator during one word interval each frame.

These shift pulses cause the information in the shifting accumulator to be delivered to the biphase modulator, and at the same time the output of the digital shifting accumulators is returned to the input so that after 12 shift pulses the state of the shifting accumulators is exactly as it began. The outputs of all the shifting accumulators are connected together, but since only one is shifting at a time no interference results.

The conversion of analog to digital information is accomplished with the aid of a digital ramp and a voltage-comparison circuit. In essence, conversion results from counting the number of steps in the ramp below the level of the analog input. The counting is actually done in a shifting accumulator, just as for digital experiments. The Explorer VI payload had six digital and four analog shifting accumulators.

The biphase modulator accepts the pulses emerging sequentially from the shifting accumulators and produces a subcarrier whose phase shifts by 180 degrees each time there is a "one" to be transmitted and retains its phase each time a "zero" is to be transmitted. This biphase modulated subcarrier is then delivered to the transmitter for phase modulation upon the carrier.

The pulses which cause the electronic commutator to step and the shift registers to shift originate in the programmer, which receives its excitation from the master clock. The programmer is equipped so that application of an outside signal derived from the digital command decoder causes the pulse rate of the digital telemetry system to change.

In the subcarrier oscillator system a series of voltage-controlled oscillators are used, in which the frequency of each channel is varied over a limited range (about 7.5 percent) by the input signal. Each oscillator covers a discrete frequency range and the outputs of the various oscillators are superimposed to form the modulation signal. Input signals to any given channel may be commutated to permit time sequential presentation of several slowly varying inputs on a single subcarrier channel. This system has the advantage of continuous, simultaneous display of several channels whose detailed changes with time are desired. Simultaneous operation of the subcarrier oscillators increases the overall operating power requirement over that for a time sequential system.

Transistorized subcarrier oscillators are available weighing about 14 grams (1/2 ounce) per channel which require a few milliwatts each of operating power. Oscillator inputs are normally voltages varying between 0 and 5 volts. In many cases this requires auxiliary electronics to raise the signal from the sensing device to the required level.

A tone-burst telemetry system was developed as a part of the Vanguard program. This system offers low weight and low operating power requirements, and a high degree of both reliability and flexibility. (Thus far, encoder systems have been specifically designed for each particular combination of signal inputs.) The signal consists of a series of tone bursts which carry information in the frequency of the burst, in the time duration of the burst, and in the time duration between bursts. Timing signals for the tone bursts, the tone durations, and the spacings are established magnetically with switching transistors used to apply appropriate signals to the magnetic cores. The encoder can accept input signals in the form of variable voltages, currents or resistances. The use of time sequential techniques permits low operating power requirements while the use of rapid scanning rates with supercommutation permits reasonably detailed time histories of rapidly changing input signals. These basic techniques have been used for telemetry systems ranging from 8 to 48 channels. These have been specifically designed to accept appropriate inputs from voltage, current, and resistance sources on each input channel. The basic 48-channel system used in Vanguard III weighs about 100 grams (3.5 ounces) prior to potting in the foam-in-place plastic, and less than 140 grams (5 ounces) after potting; it occupies a space 13 centimeters (5.25 inches) in diameter and 2 centimeters (0.75 inches) high, and has a total operating power requirement of about 10 milliwatts. The basic system, complete with batteries for about four weeks of continuous operation, weighs less than 200 grams (7 ounces). It should be pointed out that the more massive components in the system are the magnetic cores; thus reducing the number of channels does not proportionally reduce the weight. Also, the time sequential system dictates an operating power essentially independent of the number of channels.

Work is in progress on numerous advanced telemetry encoder systems, although most of this effort is directed toward use in deep space probes where signal bandwidths must be compressed to permit adequate data transmission over very long distances with reasonable radiated powers. In general, the present state of the art provides reasonable data handling capabilities for earth satellite applications.

Information Storage

Many scientific earth satellites will require some information storage device to accomplish the scientific objectives. The installation and support of an adequate number of properly located ground receiving stations to maintain continuous long-term recording of satellite telemetry signals would be prohibitively expensive.

For space science applications, two general types of information storage devices have been used. Magnetic tape recorders are used where the variations of input signal as a function of either time or position in orbit are desired: signals recorded slowly throughout the orbit or intermittently on a predetermined schedule are played back on command as the satellite passes over an appropriate receiving station. In many instances a simpler memory device may be used to store and transmit certain types of information. A wide variety of such equipment is available or under development.

The term "payload magnetic tape recorder" is not completely new in the field of rocketry. For a good many years scientists have used recorders in upper atmosphere sounding rockets. These recorders were almost always designed to be recovered and the tape recording was analyzed in the laboratory. A recorder to fill this need can be a relatively simple machine. Recording time is limited to a comparatively short rocket flight, and no in-flight playback capability is required. Power requirements are not too important or are met rather easily for short flight times.

Earth satellites and space probes, however, place new demands upon the payload recorder. The recorder becomes a part of the telemetry system and stores information, when the vehicle is not in radio contact, for subsequent read-out and transmission to the ground stations. For earth satellites the recorder may be expected to store information over an entire orbit, or somewhat over 100 minutes. As the satellite passes over a telemetry receiving station, this record must be played back and transmitted earthward in a short interval of about 2 minutes. This, then, points to one of the more difficult functions to achieve in a miniature recorder: a record-to-playback speed ratio of about 50/1.

A different type of storage device was used in the Vanguard program for the Lyman-alpha and x-ray solar radiation experiment. This device collected and stored data as a magnetic flux level during an orbit and subsequently the data were telemetered during transit of the satellite over an established ground station. This method required two magnetic storage elements, one to store peak intensity information during one orbit while the other transmits the information obtained during the previous orbit. An orbital switch sensitive to sunlight was used to switch the devices from storage to readout and vice versa.

Up to the present time, advanced payload recorders have been custom made by the various experimenters to meet their own needs. Of those produced to date, the U. S. Army Signal Research and Development Laboratory TIROS II recorder is the most elegant. This recorder is a third-generation development designed by W. G. Stroud and associates. It weighs about 1.1 kilograms (2.25 pounds), consumes about 1.2 watts during record and 2.5 watts during the brief playback period, and requires about 2300 cubic centimeters (140 cubic inches) of space exclusive of power supply. At the present stage of development the combined record/playback flutter is about 1.2 percent peak to peak. A

record bandwidth of 500 cps is easily obtained and a record-to-playback speed ratio of 1/30 is used. A current NASA program is directed toward reducing the flutter to an even lower value.

Another recorder of this general class, now being developed for NASA by the Raymond Engineering Corporation, has a 500-cps record limit, weighs about 0.9 kilograms (2 pounds) and requires about 0.5 watt operating power. It provides 200 minutes of record time with a record-to-playback speed ratio of 1/50. The total volume required is about 300 cubic centimeters (80 cubic inches) exclusive of power supply. The amount of flutter is expected to be one percent or less.

The projected space research program obviously requires information storage capacity exceeding that of the devices just discussed. To this end, a study program is being directed toward increasing tape recorder bandwidths to the maximum achievable in the present state of the art. A program is also being considered to study electrostatic recording techniques to provide higher information densities in the recording medium.

There are other memory devices which fall in a slightly different category. Here a continuous record of signal versus time is not provided, but rather a record of specific bits of data of special interest. Techniques have been created for storing information as a flux level in magnetic cores and for the non-destructive read-out of this information. Flight devices have applied this technique in two ways. In one instance, counter circuitry (in this case, handling cumulative counts of collisions with meteoritic particles) has been used to provide up to a three-decimal-digit cumulative count of events before automatic reset on a new cycle. A second application of this technique was made in storing the peak value of solar x-ray radiation during each orbit for correlation with visually observed solar flares. This general principle may be applied in studying special events where some unique signal criterion is of interest, such as maxima, minima, etc. For one application a coincidence memory is under development. In this case a maximum will be stored together with the time at which it occurred. The same technique could be applied to store the absolute value of a quantity which occurred at the same time as a special event such as a maximum or minimum of a second quantity. A switch has been developed to provide a reset signal for these memory devices which operates once each orbit, on the transition of the satellite from darkness into sunlight.

Modulation

Phase or amplitude modulation is usually used in space applications. Amplitude modulation may be obtained by modulating the emitter, base, or collector of the power amplifier, or modulating the buffer stage if one is used. Base or emitter modulation provides better efficiency if sine wave or less than 100-percent modulation is used. Since space telemetry encoders quite often provide a square-wave type of modulation,

this signal can provide an efficient way of modulating the collector by means of a transistor in series with the collector supply. Phase modulation can be accomplished by using voltage-sensitive capacitors in all-pass networks. An advantage of phase modulation is that the average power is equal to the peak power; this is not the case with amplitude modulation.

Transmitters

The choice between transistors and vacuum tubes for use in transmitters is determined by the frequency and the output power required. In the past, frequencies in the vicinity of 108 megacycles have been in most common use; however, in the latter part of 1960 the NASA Minitrack ground stations, which will probably be used as part of the overall Scout system, will be converted to operate in the 136- to 137-megacycle region (see Chapters 7 and 8). At these frequencies, transistorized transmitters can be constructed which have peak powers of about 400 milliwatts and overall efficiencies of 40 to 45 percent. Transmitters have been built using vacuum tubes as power amplifiers, which deliver average powers from 2 to 6 watts with overall efficiencies of 35 to 45 percent at 108 megacycles.

Two typical currently available 108-megacycle transmitters having the efficiencies just described are: (1) a transistorized version with an average output power of 80 milliwatts, which occupies a space 13 centimeters (5.25 inches) in diameter by 2 centimeters (0.75 inches) high and weighs about 230 grams (8 ounces), and (2) a higher power vacuum tube version which provides an average power output of 2 watts and is 13 centimeters (5.25 inches) in diameter, 3.2 centimeters (1.25 inches) high, and weighs about 340 grams (12 ounces). Frequencies approaching 1000 megacycles have been used in some instances to provide more accurate tracking. Germanium mesa transistors are currently the best choice for transistorized transmitters. Since the state of the semiconductor art is advancing rapidly, new devices should increase both the efficiency and power of transistorized transmitters.

Oscillators

Master oscillators for transmitters should be crystal controlled. Quartz crystals of the fifth overtone, operating with series resonance, are generally used in a feedback path between the collector and emitter. For good efficiency the series-resonant resistance should be less than 50 ohms. Spurious mode activity near the crystal resonant frequency should be down at least three to one to insure that the oscillator remains on the proper frequency. Oscillators operating at the output transmitter frequency usually provide the transmitter with the best efficiency. Oscillator and doubler combinations usually provide less pulling of the transmitter frequency under modulation.

Amplifiers

Power amplifiers are generally biased class C and are operated in the grounded-base configuration to simplify neutralization problems. The class C bias is readily adjustable by means of a resistor in the emitter return lead. Driving power, collector voltage, and collector loading have considerable effect on the efficiency and should be optimized for any particular application. Presently available germanium mesa transistors tend to be limited by the peak power they can deliver, approximately 200 milliwatts. To obtain higher powers, transistors may be operated in push-pull or parallel, or vacuum tubes may be used.

Command Receivers

It is sometimes necessary to communicate from the ground to the satellite or space probe for the purpose of commanding certain functions within the payload. For this purpose a satellite command receiver directed by a properly coded signal from the ground station is used. Use of a command receiver can greatly extend the useful life of a satellite when the receiver power is small in comparison to that of the telemetry system and flight instrumentation.

With present command frequencies, a typical command receiver is essentially a vhf double superheterodyne type. Command frequencies associated with the new 136-137-megacycle Minitrack frequency area are near 122 and 148 megacycles. The basic design of the components provides economical use of battery power and at the same time reasonable security against accidental interrogation from unauthorized sources.

An early model receiver used 0.5 milliwatts of the 108 Mc transmitter oscillator power as the first local oscillator and four voltage supplies tapped from the satellite batteries. These receivers required only 16 milliwatts for proper operation but were somewhat restricted in their adaptability to various satellite systems. The later models are more versatile in their ability to be integrated into command systems. This newer receiver consumes approximately 30 milliwatts but has both local oscillators self-contained in the receiver. The power supply for these units consists of a single voltage source which may be varied between 10 and 14 volts, thus the system may readily be used for either fixed-battery or solar-cell operation. When the receiver is interrogated the power consumption increases to 200 milliwatts, most of which is used for relay operation. With the normally low-duty-cycle operation of interrogation, the operating life of the receiver is about 3.5 hours per gram (100 hours per ounce) of battery weight.

The receivers are of printed circuit construction on a circular card 13 centimeters (5.25 inches) in diameter with an overall height of about 2.5 centimeters (1 inch). The receiver weighs approximately 140 to 200 grams (5 to 7 ounces). Silicon transistors are generally used in preference to germanium because of their superior temperature

characteristics. The receivers are designed to operate over a temperature range of 0° to 60°C but this operating range can be extended to -20° to 80°C without great difficulty.

For most applications the receivers are designed to have a minimum sensitivity of 90 decibels below one milliwatt throughout all environmental conditions. This figure provides a 15- to 20-db safety factor over the worst expected interrogation conditions at the field stations. A pre-detection bandwidth of 20 kilocycles is sufficient for most applications. This allows ± 4 kilocycles for doppler shift of the transmitted signal, ± 2 kilocycles for expected drift of the receiver local oscillators, and 8 kilocycles for modulation. The interrogating signal is an amplitude-modulated carrier which is transmitted for 0.6 seconds. The detected signal in the receiver is filtered to determine whether the proper subcarriers are present. To provide reasonable security against accidental turn-on, an integrating time delay of 0.1 second is provided in the relay amplifiers. Partial limiting of the signal in the last i-f amplifier prevents signals with a small percentage of modulation or with several modulating frequencies from actuating the receiver relay.

Signal Power

Successful acquisition of radio telemetry signals requires a certain minimum signal power input to the receiver. This minimum signal input power is determined by the minimum tolerable signal-to-noise ratio and the receiver noise figure. The actual signal input, under free-space conditions, depends only on the radiated power from the transmitter, the transmitter-to-receiver distance, the carrier frequency, and the gain of the transmitting and receiving antennas. Free-space conditions provide a good, simple starting point for radio systems planning. The effects of ionospheric propagation, atmospheric absorption, multipath reception, transmission line losses, component deterioration, etc., can be superimposed upon the free-space calculation as desired. With appropriate attenuation, power levels as low as 15 milliwatts have been used successfully. A more detailed discussion on power attenuation considerations is included in Chapter 8.

Antenna Design

Problems often arise when more than one transmitter is coupled to a common antenna. If there is sufficient separation between transmitter frequencies, frequency-selective networks may be used. When two transmitters are at very nearly the same frequency, a coaxial type of hybrid ring works very well in giving isolation between transmitters. This system can be used with either dipole or turnstile type antennas.

Antennas used in space operations fall into two general categories: those for rocket telemetry and those for payload telemetry. Rocket telemetry antennas are usually

single, rigidly mounted stubs. The rather directional radiation pattern is accepted since the range is comparatively short and the attitude of the vehicle is known. Satellite telemetry antennas are chosen for the most uniform and omnidirectional field possible. This is necessary since stabilized platforms are not in common use, and the payload will generally roll and, in many cases, tumble. The most popular antenna configuration for satellite telemetry has been crossed dipoles fed in phase quadrature. This is essentially a turnstile antenna such as is used for fm radio and television transmission.

A turnstile has a very nearly omnidirectional pattern in the plane of the dipoles if the separation between the phase centers of the dipoles is not large compared to the wavelength. In the practical case this separation is large and the result is a cloverleaf pattern with nulls in the order of 4 to 10 decibels. The pattern in a plane perpendicular to the turnstile, ideally, would be omnidirectional except for a 3-decibel null at the plane of the turnstile. In practice the nulls will exceed this and vary with azimuth of the payload. The three-dimensional pattern may be thought of as a sphere with four dimples in each hemisphere. The magnitude of the dimples will depend upon the size and shape of the payload and the power division and phasing of the matching network driving the antennas.

A typical procedure for antenna design is to make a mock-up of the metal surfaces of the payload. First, one half of the mock-up is mounted on a ground plane (it is assumed here that the structure is cylindrical or spherical) and the antenna radiation impedance versus antenna length is measured by the image method. In existing designs the power has been divided by a hybrid circuit formed from coaxial cables and having a nominal impedance of 50 ohms. The phasing is obtained by the addition of cable lengths. This results in a requirement of a 100-ohm impedance for each antenna. This higher impedance may be obtained by cutting the antenna to longer than resonance and matching through a short, rigid, coaxial line. This line may also serve as a mounting bracket. By adjusting the parameters of the rigid line and the length of the antenna, a good match (about 3 to 5 percent) may be obtained over a small frequency band. After determining the antenna length and the rigid-line parameters, the four antennas are mounted on the whole mockup and, after a series of cut-and-try measurements the best omnidirectional pattern may be obtained.

A major disadvantage of the turnstile antenna for payload application is the variation of the signal polarization as the package aspect changes. In the plane of the turnstile the polarization is linear; but as the aspect changes the polarization becomes elliptical, then circular, then elliptical again. As the aspect changes from one hemisphere to the other the sense of the elliptical and circular polarization also changes. This requires that the ground receiving system be able to receive all polarizations equally well — a difficult accomplishment.

Efforts are being directed toward developing antennas made of short high-efficiency radiators that do not have to fold to fit into the nose cone and do not exhibit polarization changes with payload aspect.

Off-the-Shelf Items

A wide variety of auxiliary circuitry has been produced and is under development for use in connection with space science experiments. Included are high-input-impedance electrometer amplifiers, logarithmic amplifiers, pulse height analyzers, optical and magnetic aspect indicators, counter circuits, etc. Space science experimenters can save considerable expense and unnecessary duplication of effort by determining at the earliest possible date the availability of thoroughly tested elements which may meet their needs either directly or with minor modification.

POWER SUPPLIES

General

Unless a completely passive satellite or probe is contemplated, a very basic element of any space payload system is the source of functional energy, which is usually electrical in nature. To date, two energy sources have been used: electrochemical and solar.

The chemical battery offers a source of power where the scientific objective can be fulfilled in a reasonably predictable and relatively short time span. Solar powered devices, on the other hand, offer a possibility of indefinite lifetime limited only by the failure of the first vital component.

A word of caution is appropriate at this point with respect to the use of solar power devices. Owing to the desirability of keeping radio frequency channels clear, a cutoff timer or a command cutoff system will be required when solar powered equipment is employed. At times the experimenter will find it convenient to use batteries that will become exhausted at the end of the useful lifetime of the experiment. This not only avoids the need for a specific cutoff device, but also has the indirect benefit of preventing the experimenter from being swamped with unnecessary redundant data which may never be analyzed.

Two other basic power sources currently under development, fuel cells and nuclear power systems, will provide an intermediate potential for future use. Offering greater energy per pound than electrochemical sources, they will provide greater powers for the extended but finite lifetimes needed to accomplish certain scientific missions. Since these systems are still in the developmental stage, they will not be available to designers of Scout payloads in the immediate future.

Sources

To date, most space experiments have used electrochemical power sources either in the form of primary batteries or secondary batteries which are recharged by solar cells. Probably the lone exception is the directly solar-powered transmitter in the Vanguard I satellite (1958 Beta) which contains no storage batteries. In this instance, long-term accurate tracking data were obtained for geodetic use; adequate information could have been obtained, however by operating the beacon transmitter during sunlit portions of the orbit only. With a history of over 24 months of continuous operation, this satellite has well established the reliability of transistorized transmitters and silicon solar energy converters. Obviously, any experiment devoted solely to the study of solar phenomena could be powered directly by solar energy.

Electrochemical

Batteries

Although numerous primary and secondary batteries are applicable as space power sources, most attention has been concentrated on three general types: the mercury cell, the nickel-cadmium cell, and the silver-zinc cell. A resumé of the theoretical energies of their active materials and the practical energies realized is shown in Table 2. Although shown as an electrochemical source in Table 2, the fuel cell has not yet been applied to space uses and represents a future development.

Table 2
Electrochemical Power Sources

Type of Cell	Active Materials	Watt Hours			
		Theoretical		Practical	
		Per kg	Per lb	Per kg	Per lb
Mercury	Zn/KOH/HgO	254	115	97	44
Nickel-Cadmium	Cd/KOH/NiOOH	212	96	33	15
Silver-Zinc	Zn/KOH/AgO	474	215	165	75
Fuel Cell	H ₂ /1/2O ₂	3090	1400	660 up	300 up

As is indicated by the fact that all three types of batteries have been used, each type has certain advantages but no one has clearcut superiority for all uses. The mercury battery is low in cost, is readily fabricated into high-voltage units, requires no maintenance, has relatively flat output voltage, long shelf life, and comparatively good life expectancy in vacuum. On the other hand it has poor low-temperature operation, there is a possibility of generating excessive gas within the cell, and only a limited number of types are available in nonmagnetic cases. Mercury cells have found and will continue to find widespread use in space applications where primary cells are desired.

The nickel-cadmium battery has a potentially high reliability under conditions requiring many charge and discharge cycles. Very little gas is evolved, so it is readily adapted to hermetically sealed units. Its low-temperature performance is only fair, the output voltage drops continually during discharge and, being magnetic, the battery can produce stray magnetic fields in satellites. Present indications are that hermetically sealed nickel-cadmium batteries are the most suitable storage devices available for solar-cell powered satellites.

The silver-zinc cell has the highest energy per unit weight of all known practical battery systems at high use rates, and possesses excellent voltage regulation. It is quite expensive, has undesirable low-temperature performance, can withstand only a few charge-discharge cycles, and is limited in its shelf life.

Electrochemical power sources in very small sizes do not offer equivalent energy per unit of weight that the larger cells do and the difficulty in sealing these units serves to reduce their reliability. High voltage sources may frequently be provided more reliably and efficiently by using larger, low voltage batteries with static converters, either transistorized or a transistor magnetic combination.

Fuel Cell

Probably the most promising future development in electrochemical power sources is the fuel cell. The fuel cell converts the chemical energy of recombination of a fuel and oxidizer, such as hydrogen and oxygen, directly into electrical energy and reaction products. Since it is not Carnot-limited, it can theoretically achieve 100 percent efficiency. Several basic problems remain to be solved, however before the fuel cell is a practical source of electrical energy for space operations. These include control of gas-liquid interfaces under zero-g conditions, decomposition of the catalyzing electrodes, and storage and supply of fuel and oxidizer. Fuel cells may become practical power sources for space operations in the not-too-distant future; however, they should not be counted on as a power source for Scout.

Solar

Theoretically, infinite life may be obtained in space systems confined to areas sufficiently close to the sun by utilizing solar energy to perform flight functions. Turn-off or destruct devices must be incorporated, unless the application is truly of continuous and permanent value. The silicon solar-cell power supply can be used alone or in conjunction with secondary cells where operation is desired during the non-sunlit portion of the orbit. The silicon solar cells produced in the United States typically consist of "n" type doped silicon wafers having a boron diffused "p" type layer at the active surface. When sunlight falls on the p-n junction, photons with sufficient energy to break the

valence bonds in the silicon crystal create electron-hole pairs. These electron-hole pairs then diffuse into the junction region where the junction field causes holes to flow into the "p" type material and electrons into the "n" type material. This produces a potential difference across the silicon cell, causing a current to flow through the load. Theoretically this cell can achieve 22 percent efficiency; actual production units capable of converting 9 percent of the available radiation into electrical power are now available. These units achieve power outputs of up to 9 watts per kilogram (4 watts per pound) and can provide approximately 100 watts per square meter (10 watts per square foot) projected area.

Experiments have shown that silicon photovoltaic cells are subject to degradation of power output when the p-n junction is exposed to electron and proton radiation similar to that trapped in the earth's geomagnetic field. Quartz or cerium glass cover slides may be used to shield the solar cells against protons and electrons. Research is underway to determine the shielding thickness needed for extended operation within the inner or outer radiation zones.

Other techniques are also under development for the utilization of solar energy, such as the use of closed thermodynamic cycles with fluid mechanical systems and direct thermoelectric or thermionic conversion.

Nuclear

Nuclear power sources offer a major step beyond the electrochemical systems for completely self-contained power sources. Nuclear power can be obtained either from nuclear reactors or radioisotopes. Nuclear reactors will probably not be practical as power sources for space science programs in the near future. Radioisotope sources have reached the prototype stage but are extremely expensive. Radioisotopes are produced as a by-product during a fission process or can be artificially created by irradiating suitable materials in a nuclear reactor. Actual electrical power production is accomplished by utilizing the heat generated by the absorption of particles and the electromagnetic radiations emitted during the decay process. Operating prototypes of radioisotope power sources have been produced in which the liberated thermal energy is converted into electrical energy by means of thermoelectric elements. A fully charged unit is capable of delivering over 13,000 watt hours per kilogram (6,000 watt hours per pound) over a period of two half-lives of Polonium 210 (the half-life is 138 days). Extended operating periods may be obtained by selecting radioisotopes with longer half lives. In addition to high cost and limited availability of materials, radioisotope power sources of this type have another major disadvantage: that the rate of electrical energy production is a function of the isotope used and cannot be independently adjusted. The power generated will decrease by a factor of two in each half-life and the energy not used must somehow be dissipated or stored in secondary cells. General data on an

already produced nuclear-power thermoelectric generator are shown in Table 3. Numerous other nuclear power source systems are under consideration and may find use in the long range space program. Since nuclear power sources are still in the experimental stage they will not be available for Scout use in the near future. When nuclear energy sources are contemplated for use in space vehicles, particular attention must be paid to the provision of adequate safety measures against the hazardous release of radioactive materials.

Table 3
SNAP III Nuclear Battery Data

Physical dimensions	12 cm (4.75 inches) diameter; 14 cm (5.5 inches) high
Weight	1.8 kilograms (4 pounds)
Source	1700 Curies Po^{210}
Half life	138 days
Thermal power	60 watts
Electrical power	3.3 watts
Efficiency	5.5 percent
Thermoelectric material	Doped lead telluride
Dose rate at surface	500 mr/hr
Dose rate at 5 feet	1.0 mr/hr
Watt hours	5500 per kilogram (2500 per pound) (Two half lives)
Equivalent silver-zinc battery weight	73 kilograms (160 pounds)

Conversion Devices

Many static converters have been designed, tested and flown in space systems. Typical examples include low-current high-voltage supplies for ion chambers, photomultipliers, etc., as well as plate power supplies for vacuum tube circuits. High efficiencies are obtained by generating square-wave alternating current to minimize losses in the transistors and to provide effective filtering with lightweight components. In generating square-wave outputs, transistors are normally operating in the saturation or cut-off mode except for the very brief "switching" interval. When so used, the internal power dissipation in the transistor is much less than that encountered when it is used as an oscillator to generate a sinusoidal output. The outputs, when full-wave rectification is used, consist of essentially pure direct current with very sharp "spikes" at each switching interval. Since these "spikes" contain only very high-frequency components, they can be quite effectively filtered by simple RC filters with low values of resistance and capacitance. The general capability of such devices can be illustrated by two recent examples. A static converter has been produced to supply low currents to a photomultiplier

and its associated electrometer tube. The output is 1000 volts dc; the regulation with normal variations of input voltage is better than 1 percent. The input is 12 volts dc and an operating power of 6 milliwatts is required. This unit occupies about 164 cubic centimeters (10 cubic inches), weighs about 71 grams (2.5 ounces) and is designed to mount directly on the base of the photomultiplier tube. A second unit has been produced to supply plate power for the vacuum-tube power amplifier in a telemetry transmitter. This provides about 6 watts output with an overall efficiency of about 85 percent. Operating from an input of 18 volts, it provides outputs of 250 volts at 20 milliamperes and 100 volts at 2 milliamperes, as well as 2.5 volts at 300 milliamperes for the dc heater supply. This unit also occupies a space of about 164 cubic centimeters (10 cubic inches) and weighs about 85 grams (3 ounces). Both of the aforementioned devices use magnetic cores in connection with switching transistors. Other transistor converters are available supplying powers up to 1 kilowatt to meet any specific needs.

MECHANICAL STRUCTURE

A mechanical structure must be provided to house the complete flight system and mate the assembly to the launching vehicle. In general, sensing elements have been attached to the outer shell while batteries and auxiliary electronics are placed in an inner instrumentation package. The instrumentation package normally is thermally isolated from the shell to reduce temperature fluctuations as the shell warms up in sunlight and cools in the earth's shadow. This technique provides a relatively stable package temperature at a value a few degrees warmer than the orbital mean value of shell temperature. Because of their excellent strength-to-weight ratio and ease of fabrication, aluminum and magnesium alloys have been the basic structural materials in early satellites. Filament-wound fiberglass laminates, with densities near that of magnesium and with high flexural strengths, have proven excellent in some applications, particularly where the experiment has made metallic shells undesirable. From previous experience it would seem likely that any given launching vehicle will be provided with one basic mechanical structure for the payload, upon which minor variations are made to accommodate the various experiments. In planning an experiment it should be assumed that from 20 to 35 percent of the available payload weight will be devoted to the mechanical structure.

MATERIALS

Materials for satellite use must be evaluated on the basis of their chemical, physical, and mechanical properties under the extreme environments which they will experience. Among the environmental conditions are extreme cold, vibration, extreme transient heating, moisture, dust, and rapidly varying atmospheric pressures. High vacuum is perhaps the most important factor; in ultrahigh vacuum, the absence of normally present contaminations may alter important physical properties. Material regarded as ideal for

certain applications may fail completely under some space condition: for example, most lubricating oils evaporate rapidly in a high vacuum, and one common alternative, the solid lubricant graphite, does not function as a lubricant under this condition. Accordingly, designs depending on mechanical motion of parts exposed to the space vacuum should be avoided if at all possible. This problem is particularly acute for sensing elements which cannot be hermetically sealed.

Evaporation of materials in high vacuum must also be considered. Cadmium will evaporate at the rate of 1000 Angstroms per year at 40°C, selenium at 50°C, zinc at 70°C, and magnesium at 130°C. These rates of evaporation increase very rapidly with temperature; at 120°C, cadmium and selenium lose 1 millimeter per year. The evaporation rates for other commonly used materials are too small to be significant.

Polymers tend to decompose in high vacuum, many of them even at room temperature. The following are among materials which have been reported to lose more than ten percent of their weight per year in vacuum below 100°C: polysulfides, polyesters, cellulose nitrate, epoxys, polyvinyl chloride, polyurethane, polyvinyl butyl, chloroprene, and alkyds.

Small amounts of impurities, addition agents, and polymerization catalysts have considerable effect on the vacuum behavior of polymers. This is evidenced by the fact that very large differences are found between specimens having the same commercial name. Therefore, nylon, phenols, acrylates, and cellulose acetate, which are very variable, should not be considered reliable without tests of the varieties to be used. Ethylene terephthalate (Mylar, Dacron) has been reported to lose less than 10 percent per year at 200°C; polyethylene, polychlorotrifluoroethylene, polytetrafluoroethylene, and some silicones lose less than this amount at 240°C.

Regardless of composition, some loss of surface material will also occur as a result of collisions with atoms and ions of the earth's upper atmosphere and with protons and ions from the sun. The amount lost, except in the Van Allen radiation belt, will probably not exceed a few thousand angstroms per year. Because the ion flux at 1 to 10^6 electron volts in the Van Allen Belt is not yet known, the rate of surface loss by atomic collisions in these zones is unknown. This rate may be very much higher than elsewhere in the upper atmosphere.

Material may also be lost or deformed by collisions with micrometeorites and meteors. Particularly over long periods of time, exposed optical surfaces may be subjected to appreciable surface erosion and pitting from this source.

The choice of materials is important in the temperature control of space payloads. The emissivity and absorptivity of materials in both the optical and infrared regions

affect heat transfer from the payload skin to the instruments, and completely control heat transfer from the payload outward. This illustrates that careful engineering in the choice of materials is necessary to avoid temperatures which will make instruments inoperative.

TEMPERATURE CONTROL

General

One vital consideration in space operations is the problem of maintaining, for extended periods, proper operating temperatures for all system components. Temperature failures may be mechanical, electrical or even biological. Failure need not imply the complete or even partial destruction of a component, but may involve a loss in accuracy or sensitivity of a circuit containing the component. The goal of temperature control is to assure that the critical components remain within the desired operating temperature ranges for the required lifetimes.

Since the thermal environment surrounding the payload is a function of the exit trajectory, which will differ for each mission, a detailed thermal specification cannot be written at this time to cover all flights. Present plans for Scout payloads require that sufficient heat protection be provided to maintain the payload thermal environmental conditions reasonably near the ground ambient. It is believed that the thermal limits of the payload instrumentation will require either the use of insulation inside the fairing during the early stages of flight, or some other means of keeping the temperature within the limitations imposed by the components. The basic protective nose fairing will be ejected just prior to third-stage ignition, at which time aerodynamic heating will have diminished so that the fairing will no longer be required.

The thermal environment of the payload, once in flight, will depend upon the absorption from the sun and earth and its radiation into space. Experience to date indicates that reasonable mean temperatures can be maintained with present design techniques. For any given space experimental system a detailed thermal study must be made on the basis of such factors as lifetime, orbit, permissible temperature variation of critical components, etc.

Thermal Limits

The first step in defining the thermal problem is to establish the allowable temperature limits. These limits will differ for each flight system and, moreover, may be distinct for each region or component. An additional distinction must be made between the transient and the steady-state temperature limits. In the cases of the Vanguard and Explorer satellites, steady-state temperature limits of 0° to 60°C were established.

These temperature limits were set primarily by consideration of the battery life expectations.

Passive Control

The methods of temperature control available to the space scientists may be divided into two categories: active and passive. In general, passive temperature control methods can approximate the temperature variations encountered in the earth's climates but with more latitude in the selection of median values. Space instrumentation packages can be thermally designed to have median temperatures well beyond those encountered on earth if the need arises.

The temperature of a satellite or space probe depends only on radiative heat transfer, as it is in contact with no other bodies or conductive atmosphere. The temperature is determined by the amount of radiative heat which the body receives, the heat generated internally by the payload components, and the heat which the body re-radiates or reflects to the surrounding space. The time rate of change of the temperature satellite temperature can be expressed by the following equation:

$$\frac{dT_s}{dt} = \frac{\alpha_1 (I_{s_1} + I_{s_2}) + \alpha_2 I_E + P - \epsilon \sigma T_E^4 A}{MC},$$

where

T_s = temperature of vehicle shell,

t = time,

α_1 = absorptance of vehicle's surface to solar radiation,

I_{s_1} = solar power directly incident upon the satellite vehicle,

I_{s_2} = solar power reflected to the vehicle from the earth,

α_2 = absorptance of vehicle's surface to terrestrial radiation,

I_E = terrestrial power incident upon the vehicle,

P = power dissipated within the vehicle,

ϵ = emittance of satellite's surface,

σ = Stefan-Boltzmann Constant,

T_E = the effective temperature of the earth,

A = vehicle's surface area, and

MC = vehicle's heat capacity.

The terms representing the surface integrals of the radiant flux incident upon the vehicle (I_S and I_E) can be expressed as functions of time, as they are dependent on the shape, position, and attitude of the vehicle. The temperature-time history of the vehicle can be obtained by integrating the equation. This treatment applies to the evaluation of the temperature of any body in space.

The mean temperature of the vehicle can be controlled by selecting a surface for the vehicle with a ratio of α_1 to E such that the two equilibrium temperatures ($T_{s_{\max}}$ and $T_{s_{\min}}$) bracket the desired mean temperature. Twenty percent of the steel surface of Explorer I was coated with Rokide in order to achieve an average temperature of about 25°C. The ratios of α_1 and α_2 of the steel and Rokide-coated steel are 1.9 and 0.37, respectively. Figures 12 and 13 show the reflectances of these materials as functions of wavelength. A detailed discussion of the selection of the Explorer surface material is presented in References 5 and 6.

Satellite skin temperatures may vary by more than 100°C during each orbital period; therefore equilibrium temperatures are never achieved because of the thermal inertia of the vehicle. Insulating the satellite instrumentation from the vehicle's skin by its mounting provides the payloads with thermal time constants equal to several times the orbital period, thus restraining the variations of internal temperature to tolerable limits.

Passive temperature regulation can be achieved by controlling the absorptivity to emissivity (α/ϵ) ratio of the outer surface of the satellite or probe. Thus, a poor absorber in the short-wavelength region and a good emitter of radiant energy in the long-wavelength region will tend to assume a low temperature, and similarly a good absorber and a poor emitter will tend to operate at a high temperature. Proper selection of the α/ϵ ratio can keep temperature excursions within reasonable limits; however, these excursions cannot be accurately controlled because of variations in such things as percentage of time in sunlight (which varies from about 55 to 100 percent for a given satellite orbit, depending upon the season), the earth's albedo (including variation with cloud cover), the variations of the predicted from the actual orbital parameters, etc. These conditions are beyond the control of the thermal designer.

A wide variety of methods to control the α/ϵ ratio are available to aid in establishing the desired thermal equilibrium temperatures, but the method used may have non-thermal

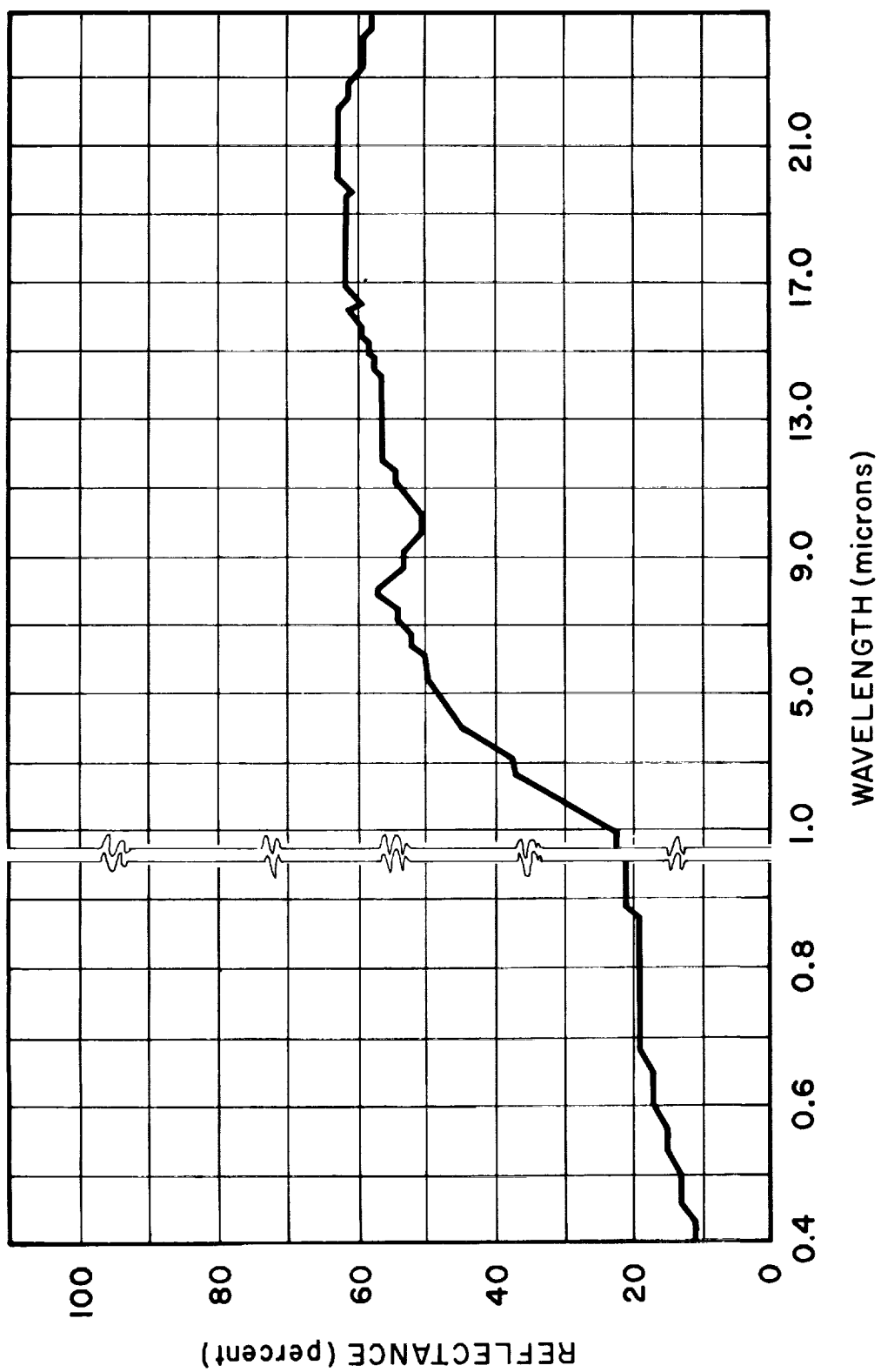

Figure 12 - Reflectance as a function of wavelength for 410 stainless steel (fine, sand-blasted, heated in air to 600°F)

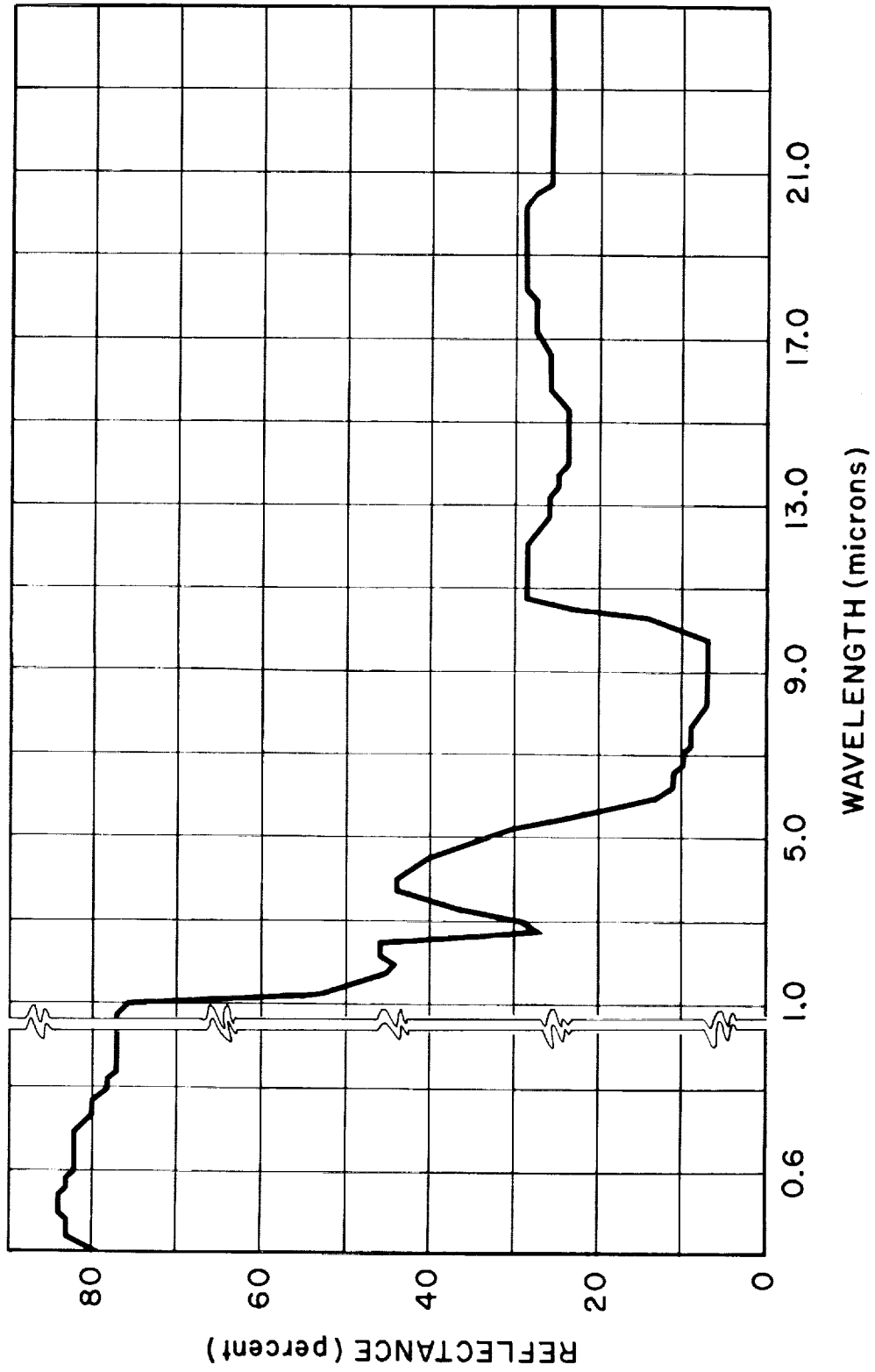

Figure 13 - Reflectance as a function of wavelength for 0.012 Rokide A on 410 untreated stainless steel

implications. For example, unless the satellite is large, the control of temperature by means of relative areas of good radiators and absorbers, as was done in the early Explorer satellites, is quite impractical if the requirement of good optical visibility (which was placed on the Vanguard satellites of the same era) is to be met. For the Vanguard satellites, the outermost coating material was transparent to visible wavelengths and relatively opaque in the infrared. The effect of this coating material was to alter the visible reflectivity of the specularly reflecting under-material only slightly, but to increase the low-temperature emissivity by a large amount. The coating process was developed by Dr. George Hass of the U. S. Army Engineer Research and Development Laboratory, Fort Belvoir, Virginia. It involves the placing of a thin evaporated layer of silicon monoxide (SiO) over a plated gold surface, overlaying this with an opaque film of evaporated aluminum to provide high reflectivity, and finishing with a film of partially oxidized silicon monoxide to yield the desired value of emissivity. A satellite shell thus prepared has an emissivity of 17 to 60 percent with an absorptivity for sunlight in the order of 17 to 23 percent.

Surfaces and coatings of considerably greater and lesser α/ϵ ratios are considered practical. If heat sources or heat sinks are required for temperature control purposes or to provide thermal operating power for satellite functions, such ratios would be useful. There is a possibility that passive temperature controls operating within narrower limits may become practical through the development and use of coatings whose α/ϵ ratio varies with temperature, i.e., α remains fixed while ϵ increases with temperature, thereby providing a measure of automatic control.

Active Control

Where more precise temperatures are required for specific needs, active temperature control must be provided. Rough control for limited use can be provided by a heat-switch system controlling the thermal conductivity to the shell, in which the shell itself is periodically used as a heat source or sink during its alternate high and low temperature periods around the orbit. More precise control can be obtained by the use of thermal switches in connection with heat source and heat sink vanes having the proper α/ϵ ratios and ample thermal capacities.

Additional information on thermal control devices can be found in Reference 4.

REFERENCES (Chapter 4)

1. Taber, John E., "Able 3 Payload Design," Institute of Radio Engineers, Transactions on Military Electronics, Vol. MIL-3, No. 4, October 1959, pp. 143-149

2. Hibbs, A. R., "The Temperature of an Orbiting Missile," Jet Propulsion Laboratory Progress Report No. 20-294, March 28, 1956
3. Buwalda, E. P. and Hibbs, A. R., "Satellite Temperature Measurements for 1958 Alpha, Explorer I," Jet Propulsion Laboratory External Publication No. 481, April 23, 1958
4. Blagonravov, A. A., "Some Problems of Providing for Scientific Research on Rockets," Amer. Rocket Soc. J. 30(1):22-27, January 1960

CHAPTER 5

ENVIRONMENTAL TESTS

The determination of an adequate test program is a prime problem in environmental testing for an effective space program. The program of environment testing presented herein is based primarily on the Explorer and Scout Programs.

A complete plan for all types of tests should be drawn up for each satellite payload well in advance of the actual testing period. Such a plan should take into account, among other things, lifetime requirements, stability characteristics, compatibility between component parts, and potential sources of rf interference.

FLIGHT ACCEPTANCE AND DESIGN APPROVAL TESTS

On a statistical basis it has been shown that if the payload is to accomplish its mission, the reliability of each component in a large system must be very high. The approach taken to achieve this reliability is known as Flight Acceptance Testing. In this procedure the components are subjected to the most accurate possible simulation of the environment in which they must function. This is followed by building subassemblies and subjecting these too to environmental tests. When each subassembly has passed the tests, they are combined to form a complete prototype unit which is also put through a series of environmental tests. When the prototype is accepted, the design is considered to be approved and can be used to build the final flight payload.

The philosophy of acceptance testing to achieve reliability has been debated for many years. It has been generally concluded that if the equipment is poorly designed, it will not survive the rigors of the tests imposed up to and including the prototype design. Furthermore, the tests provide a check on the quality of workmanship which may well result in a significant improvement in reliability. Finally, even though there may be neither time nor money to run through the complete gamut of tests, as many as possible should be made to increase reliability in flight.

An important aspect of environmental testing is the design of the test. Unfortunately there is no one set of rules to be followed for all cases. One tool which exists, however, is the Design Approval Test which has proven useful in promoting good engineering design. In this test the various stages of payload development through the prototype unit, (particularly equipment of new design), are required to withstand conditions approximately 50 percent more severe than those anticipated in the flight environment.

Imposing such a requirement, even on only some of the component parts, increases the probability that the entire payload configuration will endure the flight environment successfully. Although the effect of this requirement is that the engineer must overdesign the equipment, experience has shown that the resultant weight penalty is small as compared to the large gain in reliability. Payload units which have been subjected to Design Approval Tests are generally not acceptable as flight units because of the severity of the tests imposed.

Even though the prototype unit has passed the Design Approval Test, it is still necessary to conduct simulated environmental tests on the final flight unit. These tests are generally less severe, and if the flight unit survives it can be considered ready for launching.

Typical prototype and flight test specifications, as prepared for satellite payloads including those to be flown in Scout, are shown in Appendix A. It should be borne in mind that environmental test specifications consistent with the flight requirements must be prepared for each satellite payload. Appendix A is given only to indicate the possible scope of such specifications, and therefore should be considered merely a preliminary guide.

The testing of the Explorer satellites (Figures 14 and 15) represented an effort to simulate the environments encountered by the vehicles to the highest degree commensurate with the state of the art of environmental testing. Flight Acceptance Tests were performed to verify the satisfactory quality of the workmanship employed in the construction of individual units. Design Approval Tests were performed on a sample payload to verify that the design of the units had sufficient integrity to withstand environments considerably in excess of those expected. The acceptance testing of all flight equipment in the Explorer program, in preference to any sampling or test-to-failure program, was dictated by the high reliability desired and by the lack of statistical information concerning the actual reliability of the units.

Moreover, flight acceptance testing was the only technique which would assure that custom-made radio frequency transmitters such as Microlock beacons (see Chapter 7) would provide satisfactory signals for low-power reception when subjected to the severe environmental conditions expected during the launch and orbiting phases. A large portion of all space exploration instrumentation in the future will be developmental equipment; therefore, 100 percent flight acceptance testing will be required to determine the operational characteristics of each unit in the expected environment.

EXTENT OF TESTS

Formal testing in the case of the Explorers was limited to the simulation of mechanical and thermal environments. The effects of other environments such as reduced

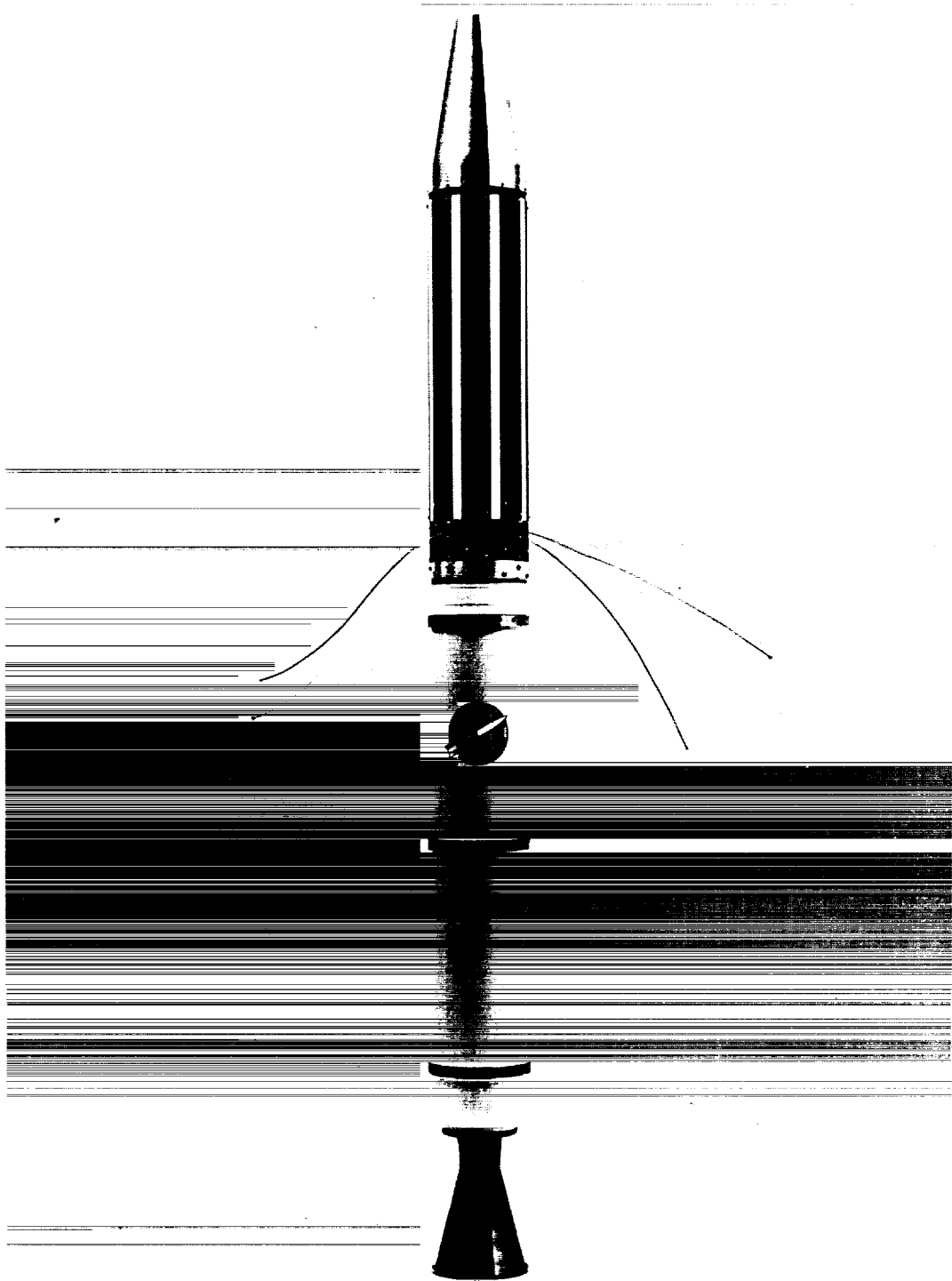

Figure 14 - The Explorer I payload

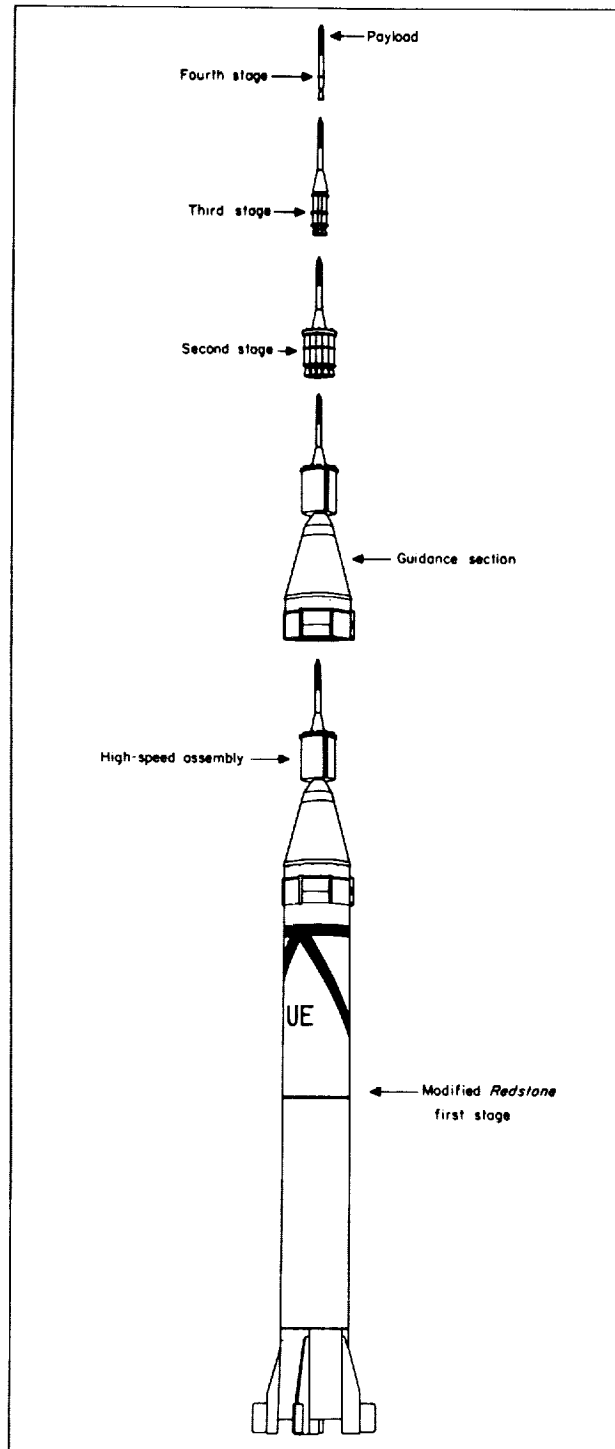

Figure 15 - The Jupiter C vehicle

pressures, cosmic radiation, and micrometeorites, were evaluated by experiment or calculation during the feasibility study phase of the satellite work; these effects were determined to be negligible (References 1 and 2). However, the proper pressure level was maintained in the course of the thermal tests, to obviate any possibility that thermal conduction, due to residual gas would disturb the temperature distribution in a test payload.

Mechanical

The mechanical tests specified to simulate the launching environments encountered by the Explorers, as prepared by the Jet Propulsion Laboratory, are summarized in Table 4. Examination of this Table shows that there are no "magic numbers" correlating the levels for the Flight Acceptance and Type Approval Tests. The Flight Acceptance Tests were selected to simulate the more severe features of the expected flight environment, whereas the Type Approval Tests were selected to provide confidence in the environmental integrity of the units.

The mechanical testing was not conceptually different from that generally employed for missile components or space probes. Test levels and durations for static accelerations and spin, if any, must be determined from launching-system parameters. Shock and vibration tests should, however, be based on flight data available, or on data from restrained firings.

The last stage of the Scout will be an Allegany Ballistics Laboratory X-248 rocket, which was also used in the Vanguard and Thor-Able vehicles. Payloads will probably experience between 10 and 40 g static acceleration during the launching phase. The exact value of acceleration to which the payload will be subjected will depend on the payload weight. It is estimated that the maximum continuous acceleration loads due to rocket thrust imposed on the payload are approximately:

1st Stage	5.5g	
2d Stage	10g	
3d Stage	14g	(22.7-kilogram, 50-pound payload)
3d Stage	11g	(136-kilogram, 300-pound payload)
4th Stage	30g	(22.7-kilogram, 50-pound payload)
4th Stage	8g	(136-kilogram, 300-pound payload)

The tentative vibration test specification for Scout payloads included in Appendix A is shown only to indicate the scope of such tests; the actual specifications used must be based on the anticipated mechanical environment for the particular payload. The specification should be considered only tentative, since the actual vibration environment has not yet been experimentally determined for Scout. Tests are presently being made on the Scout vehicle so that specific environmental test specifications can be written.

Table 4
Mechanical Environmental Tests for Explorer Payloads

Nature of Test	Type Approval Test*		Flight Acceptance Test	
	Level	Time	Level	Time
Shock: applied by ballistic hammer	100 g	Repeated 4 times		
Vibration: random noise (15-1500 cps)	20 g (rms)	0-3 min. (3 min per plane for 3 planes)	25 g (rms)	0- 0.1
			15	0.1- 8.0
			25	8.0- 8.1
			15	8.1-16.0
			25	16.0-16.1
			15	16.1-24.0
Static acceleration: parallel to axis	60 g	0-5 min	60 g	1 min
Spin: about thrust axis	1100-1500 rpm	0-10 min	750 rpm	0-5 min

*Rise time dependent on payload structure (usually less than 3 msec in test performed).

Thermal

The design approval temperature tests were performed on the Explorers to verify that the insulation employed in the vehicle was sufficient to hold the instrumentation within its operating temperature range while the shell temperature varied as in Figure 16 (see Reference 3). The differences between the two curves shown are the result of launching time, altitude, precessional and seasonal effects.

For the design approval testing, a sample Explorer shell was fitted with temperature control coils. The design approval payload was instrumented with thermocouples, assembled within this shell, and activated. The unit was then placed within a vacuum chamber, the pressure reduced to less than 1 micron Hg. and the shell temperature varied through several cycles of each program (Figure 16). The test setup is shown in Figure 17. The test was considered successful if the units operated satisfactorily throughout the tests and if the instrumentation temperatures remained within the 0° - 50°C range.

The flight acceptance temperature tests were performed on flight payload subassemblies, in conventional test chambers, in order to determine their operational characteristics within the expected 0° to 50° C range

Preliminary thermal vacuum test specifications for Scout payloads are included in Appendix A.

SOUNDING ROCKETS FOR TESTING SATELLITE EQUIPMENT

The region up to altitudes of about 241 kilometers (150 miles) has been under study by means of rockets for many years. In these experiments, and with the particular instrumentation used, the various groups concerned have learned what they must or must not do to make their experiments successful. Now that satellites are being instrumented, the sounding rocket has acquired an additional mission: that of checking out such equipment before it is employed in a satellite.

When the cost of a satellite launching vehicle, and the lead time required to obtain such a vehicle, are compared to the cost of the sounding rocket and its lead time (a factor of four in both money and time is reasonable here), it is obvious that a sounding rocket flight to test satellite equipment is at the very least, excellent insurance. Some specific ways in which the sounding rocket will prove useful are:

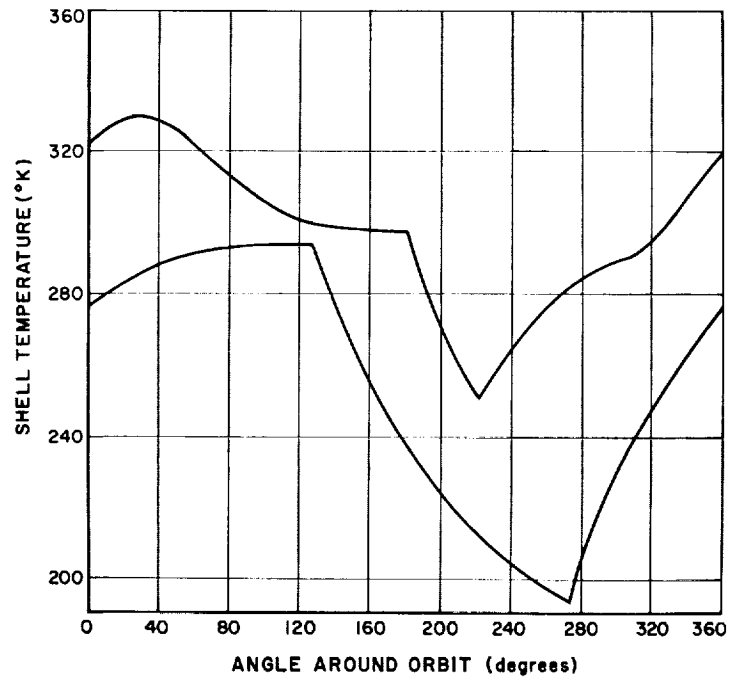

Figure 16 - Periodic variations of Explorer shell temperatures (two extremes)

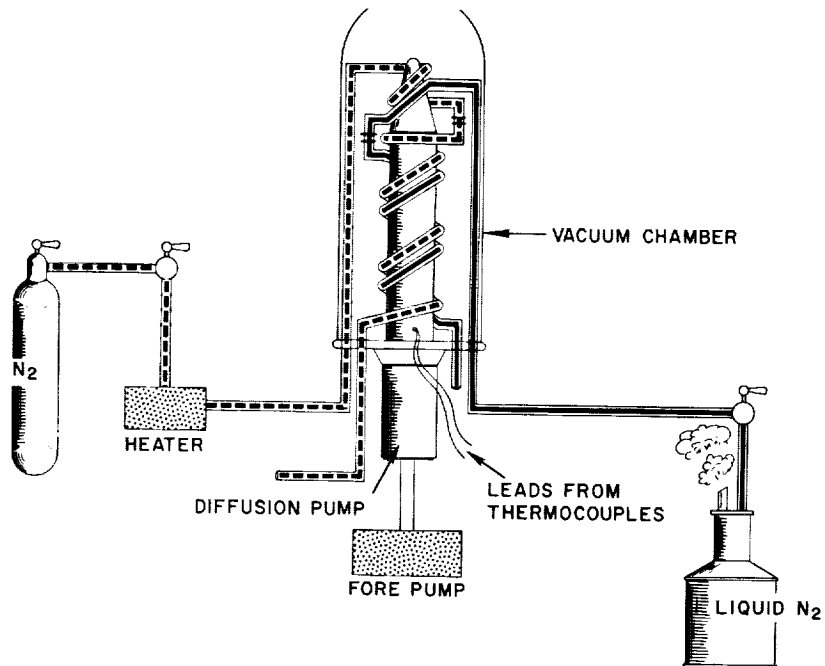

Figure 17 - Explorer temperature test system

1. The experimenter can gain experience in the methods and techniques to be employed in building equipment. Since the sounding rocket generally provides the "softer" ride, it becomes the stepping stone to the more sophisticated satellite equipment.

2. As knowledge is increased, new fields of endeavor appear and ideas are proposed which lead to improved techniques of measurement in the fields under study. The economy of the sounding rocket makes that vehicle admirably suited for testing new devices.

3. The use of sounding rockets which penetrate satellite altitudes provides the means to determine the level of intensity of the phenomenon to be investigated by the satellite, and thus the proper adjustment of instrumentation to be used on the satellite equipment. Such knowledge is necessary to the new experiment and the new experimenter alike.

4. It is a matter of experience that scientific results are sometimes different than those anticipated and, therefore, considerable difficulty is encountered in reducing and interpreting data. In such cases a slightly different initial approach to the experiment or to the information relayed might obviate many of these difficulties. The sounding rocket provides a means of deriving additional information required for the proper interpretation of data.

5. The rocket flight provides a link between satellite and ground measurements.

It can be seen then that the sounding rocket provides a high degree of flexibility to the experimenter. As planning and preparation for a satellite experiment progress, the experimenter can test ideas and equipment at a comparatively low level of effort in order to assure that the satellite equipment is adequately designed and that the data acquired can be interpreted properly.

The usefulness of the rocket is limited, however, in that it gives a cross section of data at only one location along the satellite's path. Another limitation which must be remembered is that the operating environment encountered by the sounding rocket is not as strenuous as that of the satellite. For example, accelerations may be smaller, heating less intense, and overall equipment balance requirements less severe.

TEST FACILITIES

Experience has shown that the time spent in testing represents a large portion of the overall development phase. The adequacy of the environmental tests is directly related to the adequacy of the facilities available to conduct those tests. For those groups working in a cooperative program with NASA for the preparation of Scout payloads, arrangements can be made for the use of NASA environmental test facilities subject, of course, to their availability.

In addition to the NASA centers, many industrial organizations maintain equivalent facilities, use of which can be arranged on a contract basis. The discussion that follows

describes the facilities available at NASA-directed laboratories.

Langley Research Center, Hampton, Virginia

Specialized experimental facilities are available at the Langley Research Center. Those of prime interest to satellite and probe vehicle payload designers include:

Two 41-ft diameter vacuum spheres (1 mm Hg).

100-ft³ very-high-vacuum chamber (10^{-6} mm Hg).

200-ft³ (5.6-m³) high-thermal-vacuum chamber (10^{-4} mm Hg). Includes hot and cold wall capability for simulating free-space conditions.

Vibration, shock, and acceleration machines for instrumentation checks. Largest vibration tables have 7000-lb capacity.

Small rocket test stands.

High-temperature quartz-tube radiant heaters for structural temperature tests. In addition, the Structures Research Division has a large variety of structural and materials testing equipment.

Test facilities and experimental background in wide variety of pyrotechnic devices.

Antenna design and test facilities including special hot jets for testing effects of ionized gases on antennas.

Air-bearing three-degree-of-freedom tables for testing space stabilization systems. Equipment is being developed for testing in vacuum facilities.

Static and dynamic balancing facilities.

Goddard Space Flight Center, Greenbelt, Maryland

The Goddard Space Flight Center is responsible for the design and fabrication of payloads for satellite and sounding-rocket missions. Many of the facilities available to the Goddard Space Flight Center have been provided by the Naval Research Laboratory. However, a Center is under construction at Greenbelt, Maryland to improve the GSFC with its own capability. Initial elements of the organization occupied the new facilities late in 1960, and the entire organization will be housed in the Center by 1962.

An integrated environmental test laboratory is being established to simulate the extremes of natural and induced forces which space probes and satellites must experience in their life cycle of ground handling, launch, flight, re-entry, and landing. The three-year development of this facility will produce a capability for evaluating complete payload systems weighing in excess of 10,000 pounds. The environmental parameters which

can be program-controlled during systems tests will include solar radiation, infrared radiation, cold of outer space (77° K or colder), vacuum encountered at altitudes in excess of 3000 kilometers, and the induced effects of acceleration, vibration (both random and sine wave), and shock excitations. The facility will include complete instrumentation and analytical supporting equipment.

A Space Computing Center is maintained and operated by the GSFC which provides all computations required in support of the tracking and telemetry network operations. In addition the GSFC develops, provides, and operates special and routine data conversion and reduction equipment for the rapid processing of telemetered data into the form required by the experimenters for their final analysis.

George C. Marshall Space Flight Center, Huntsville, Alabama

The following general types of tests have been performed on satellites by the George C. Marshall Space Flight Center (formerly the Development Operations Division of the Army Ballistic Missile Agency):

- Spin
- Vibration
- Shock (linear accelerator)
- Acceleration (centrifuge)
- Acceleration with satellite spin (centrifuge)
- Acceleration with satellite spin (rocket sled)
- Temperature-vacuum calibration, including vacuum soak tests

The following tests or measurements have been performed on satellites or satellite systems:

- Static and dynamic balancing
- Moments-of-inertia determinations
- Vibration amplification characteristics
- Thermal transfer characteristics
- Energy dissipation of vibrating systems
- Bending-fatigue characteristics of vibrating systems
- Separation of last-stage shell from satellite
- Flexible antenna release from satellite
- Damping of satellite nutation
- Magnetic drag measurements

Facilities which have been used for satellite tests include the following (all are located at MSFC except the 41-ft vacuum chamber):

MB Co. vibration tables Model C25H, 5-2000 cps,
3500-lb maximum force vector

MB Co. vibration tables Model C25HB, 5-2000 cps,
5000-lb maximum force vector

Mechanical vibration table, 0-60 cps, 6000-lb
maximum force vector

Tenney environmental chamber, 64 ft³, -125° to
+350°F, 0.09 mm Hg

Four Environmental chambers, 1.5 ft³, -120° to
+350°F

Vacuum chamber, Consolidated Electrodynamics
Corp., 4-ft inside diameter by 6 ft long, 10⁻⁶
mm Hg, internal liquid nitrogen coils

Vacuum chamber, 22-in. inside diameter by 60 in.
long, 5 × 10⁻⁴ mm Hg

Vacuum chamber, 12-ft inside diameter by 64 ft
long, 8 mm Hg, internal steam pipes

Vacuum chamber, 41-ft sphere, 1 mm Hg
(Langley Research Center)

Magnetic field apparatus, 0-150 gauss, working
space about 4-ft inside diameter by 4 ft long

Two Centrifuges, Genesco No. C159, 100-lb
capacity, 2000-lb force, 4-ft arm

Two Centrifuges, Genesco No. D184, 10-lb capacity,
1000-lb force, 1-ft arm

Centrifuge, 500-lb capacity, will accept 5-ft cube;
8-ft arm, 100-g acceleration limit

Humidity chamber, 100 ft³, -10° to +300°F, 0 to
100 percent relative humidity

Rocket sled, 35-g maximum for about 0.5 second,
100-lb payload

Dynamic balance stands available for weights and
shapes up to and including JPL cluster

Adjustable oscillator for determining bending-

fatigue characteristics of wires and small parts
 Pendulum apparatus for determining energy loss
 through bending of wires and other flexible items

Jet Propulsion Laboratory, Pasadena, California

The Jet Propulsion Laboratory (JPL) is a facility of the California Institute of Technology and is operated under contract to the National Aeronautics and Space Administration. It is responsible for the design of experiments and the fabrication of payloads for unmanned missions involving lunar and deep space probes. A summary of the present equipment and capabilities of the Environmental Test Facility of the Jet Propulsion Laboratory is given in Table 5.

Table 5
 JPL Environmental Test Facilities

VACUUM EQUIPMENT	SIZE	ULTIMATE VACUUM
Bell Jar, Glass, CEC	18" x 30"	20×10^{-6} mm Hg
Bell Jar, Glass, CEC	18" x 30"	20×10^{-6} mm Hg
Bell Jar, Glass, JPL	18" x 30"	2×10^{-2} mm Hg
Bell Jar, Metal, NRC	24" x 36"	1×10^{-6} mm Hg
Horizontal, Metal, CEC	30" x 45"	3×10^{-5} mm Hg
Vertical, Metal, JPL	*6' x 7'	60×10^{-6} mm Hg
VIBRATION EQUIPMENT	CHARACTERISTICS	
Accelerometer Calibrator, JPL	50-100 cps, 0.5 to 10g peak or rms	
25-pound Shaker	10 cps to 2 kc, Sine Wave only	
1,200-pound Shaker, MB Model C-10	15 cps to 2 kc, 20g rms Random 20-1500 cps into 40-pound load [†]	
1,200-pound Shaker, MB Model C-10	15 cps to 2 kc, 20g rms Random 20-1500 cps into 40-pound load [†]	
3,500-pound Shaker, MB Model C-25H (to be installed in Building 113 for hazardous tests)	15 cps to 2 kc, 20g rms Random 20-1500 cps into 120-pound load [†]	
5,000-pound Shaker, MB Model C-25HB	15 cps to 2 kc, 20g rms Random 20-1500 cps into 180-pound load [†]	
5,000-pound Shaker, and Oil Table, MB--JPL Model C-25HB	15 cps to 2 kc, 20g rms Random 20-1500 cps into 150-pound load [†]	
7,000-pound Shaker, MB Model C-70	15 cps to 2 kc, 20g rms Random 20-1500 cps into 250-pound load [†]	
15,000-pound Shaker, Hydraulic, Century Engineers	0.5 cps to 60 cps, sine wave only	

(continued)

Table 5 (Continued)

SHOCK EQUIPMENT		CHARACTERISTICS
Ballistic Hammer Hyge		10 - 125g (40-Pound Payload) 100g into 400 Pounds (160,000 Foot-Pounds for 12 msec.)
TEMPERATURE	SIZE	TEMPERATURE RANGE
Bemco (Dry Ice for Cooling)	1' x 1' x 1'	600° to -100° F
Conrad	26" x 26" x 24"	250° to -100° F
Conrad	26" x 26" x 24"	250° to -100° F and 95 percent RH; ± 1° F Control, Cam Programming
Bemco (Humidity Only)	3' x 3' x 3'	95 percent RH from Ambient to 160° F
Bemco	6' x 6' x 6'	300° F to -100° F and 95 percent RH; Cam Programming
Combined Temperature and Vibration on 7,000-pound Shaker	31" x 31" x 31"	200° F to -55° F
CENTRIFUGES	SIZE	RANGE
Genisco 159	24" x 24" x 18"	2000g Pounds 100 Pounds Maximum 75g Maximum
Genisco A1030	23" x 23" x 23"	10,000g Pounds 100 Pounds Maximum 175g Maximum
SPIN EQUIPMENT	SIZE	RANGE
Rucker	12" Diameter	300 to 1500 rpm
CORROSION	SIZE	RANGE
Salt Fog Chamber, Industrial	26" x 36" x 48"	Ambient to 125° F

*The 6 x 7 foot chamber was modified to include solar radiation and liquid nitrogen walls for June 1960 use.

† The load weights listed are for guide purposes only. The weights are higher than catalog ratings, but reflect the operating experience of the Environmental Test Facility.

SUMMARY

The economic necessity for high reliability dictates a major role for environmental testing in the exploration of space. High reliability can be achieved only through extensive environmental testing. The environments most likely to be simulated in the testing of earth satellites and space probes are: mechanical, thermal, reduced pressure, and particle radiation.

REFERENCES

(Chapter 5)

1. Pilkington, W. C., "Effects of Irradiation on Transistors," Jet Propulsion Laboratory, External publication No. 366, Pasadena, California, April 1, 1957
2. Sampson, William F., Richter, Henry L., and Stevens, Robertson, "Microlock: A Minimum-Weight Radio Instrumentation System for a Satellite," Jet Propulsion Laboratory, Progress Report No. 20-308, Pasadena, California, November 14, 1956
3. Buwalda, E. P., and Hibbs, A. R., "Satellite Temperature Measurements for 1958 Alpha, Explorer I," Jet Propulsion Laboratory, External Publication No. 481, Pasadena, California, April 23, 1958

CHAPTER 6

LAUNCHING

The NASA Wallops Island facilities described below are available to activities using Scout as a launching vehicle. It is expected that all Scout launchings scheduled for the near future will take place from the Wallops facility, although Scout launch capability will be provided at the Air Force Missile Test Center, Cape Canaveral, Florida; and at the Pacific Missile Range, Point Arguello, California.

SCOUT LAUNCHING TOWER

Photographs of the Scout launching tower were shown in Chapter 2, Figures 2 and 3. The tower is about 32 meters (105 feet) high and about 3.6 meters (12 feet) square at the base. It is designed to withstand winds up to 96 kilometers (60 miles) per hour without guy lines, and provision is made for guying to peripheral deadmen in case of higher winds. The tower provides a means of erecting the Scout vehicle and servicing the various transition sections, rocket motors and wiring while the vehicle is being prepared for firing. To provide adjustable launching azimuths, the tower is mounted on tracks. The current design of the launch pad limits the total azimuth travel to 90 degrees; 360-degree coverage could be provided, however, by extending the circular tracks. At Wallops Island the azimuth range is from 90 to 180 degrees true; however, range safety considerations limit the azimuth to less than 180 degrees true. The actual azimuth attainable is dependent on safety requirements of specific launchings. The elevation angle of launching may be varied between 70 and 90 degrees. Work platforms provided at each transition section are equipped with floodlights and intercommunication circuits. The platforms may be swung to either side by hydraulic actuators to clear the vehicle. A 454-kilogram (1000-pound) elevator services all working levels.

The Scout is attached to the launching beam by supports which engage fittings at the rear and front of the first-stage motor. The two rear supports are located on either side of the vertical fin about 45 degrees from the vertical. The front support arm is split and swings away after first motion to clear the upper vertical fin. After being assembled in the horizontal position, the first two stages are attached to the beam which is then hoisted by cable to the vertical position. A hydraulic actuator is then attached to the beam for positive, precise control of the launch angle. The hydraulic actuator can set the beam

angle as desired within the range from 90 to 70 degrees. The third- and fourth-stage motors, associated transition sections, and the payload are assembled in the vertical position. During the buildup, the hoist on top of the tower is used to handle these components.

The outer 3 meters (10 feet) of the work platforms are enclosed by a transparent Lucite screen. This enclosure, which runs from the first platform up over the top of the vehicle, is supplied with air which can be heated or cooled as required. It maintains the temperature (70° F) of the upper-stage rockets and provides a desirable working environment. The first-stage motor is covered with an electrically heated mat which is thermostatically controlled to maintain a motor temperature of 70° F during the pre-launch assembly.

Electrical connections to the vehicle are made mainly by pull-away connectors at the base of the wiring tunnels. Umbilical connections to the payload section and the guidance section (transition D) are provided with hydraulic disconnect actuators. A special plumbing system is built into the launcher to charge the hydrogen peroxide tanks for the control jets. Decontamination showers are provided on the work platforms where the charging operation is performed. Alignment of the vehicle and orientation of the guidance platform are monitored optically. The launching operation as a whole is controlled from a central control point, while guidance, control, and telemetry operations are monitored from a blockhouse adjacent to the launching site.

As a general rule the last manual operation performed on the vehicle before the platforms are swung away in preparation for firing is the arming of the rocket motors. It appears that the last access to the vehicle will be at least one hour prior to the nominal launch time. The payload would, of course, have to be installed prior to this time.

Range clearance must be obtained before each flight. This requires that the test range from which the vehicle is to be launched know the expected trajectory and impact area of each stage of the vehicle, and the probable accuracy of each impact area. The calculation of the trajectory and impact areas of the initial stages of Scout will be carried out by the organization responsible for launching the vehicle and will be based on the requirements of the experimenters.

Since the solid propellants are potential explosives, and since concentrated hydrogen peroxide is used in the control system, good safety procedures are mandatory around the launching area. This is particularly true during control assembly and testing and during arming operations. All firing ranges have their own unique safety regulations which are made known to all range users. It is recommended that groups planning to use a specific facility familiarize themselves with those regulations sufficiently in advance that compliance will not offer a last-minute burden.

FLIGHT TEST RESPONSIBILITIES

Vehicle

The Scout Project Group located at NASA's Langley Research Center has responsibility for all items pertaining to the assembly, testing, instrumentation, and launch of the vehicle. The majority of this work is performed by contractor personnel under the inspection of project personnel. Selection of the trajectory based on the experimenter's requirements, and coordination of payload and vehicle interface problems are also the responsibility of this group. The Project Group will analyze and publish all data pertaining to vehicle performance and trajectory.

Range

The particular launch facility will be in charge of all range safety measures for flights from that range. The measures include final approval of all operations on or near live rocket motors, and on or near the launchers both before and during the final countdown. Details of procedures, such as battery charging, application of voltage to instrumentation, and power switching from external to internal sources, are subject to their safety rules. The Range Officer obtains clearance for all flight plans and has final approval of all trajectories.

The range will also be responsible for obtaining the radar tracking data, atmospheric data including winds and density to high altitudes, the vehicle telemetry data, and long-range photographic coverage.

LAUNCH FACILITIES

Wallops Station

The testing range at Wallops Station, near Chincoteague, Virginia, was originally developed as a facility for testing rocket vehicles flown by the Pilotless Aircraft Research Division of the Langley Research Center. Figure 18 shows the environment and geographic location of the Wallops Station. It is now a prime launching site for the smaller rocket vehicles flown by NASA and is under the jurisdiction of NASA's Director of Space Flight Programs. This testing range will be used for initial launchings in the Scout vehicle program.

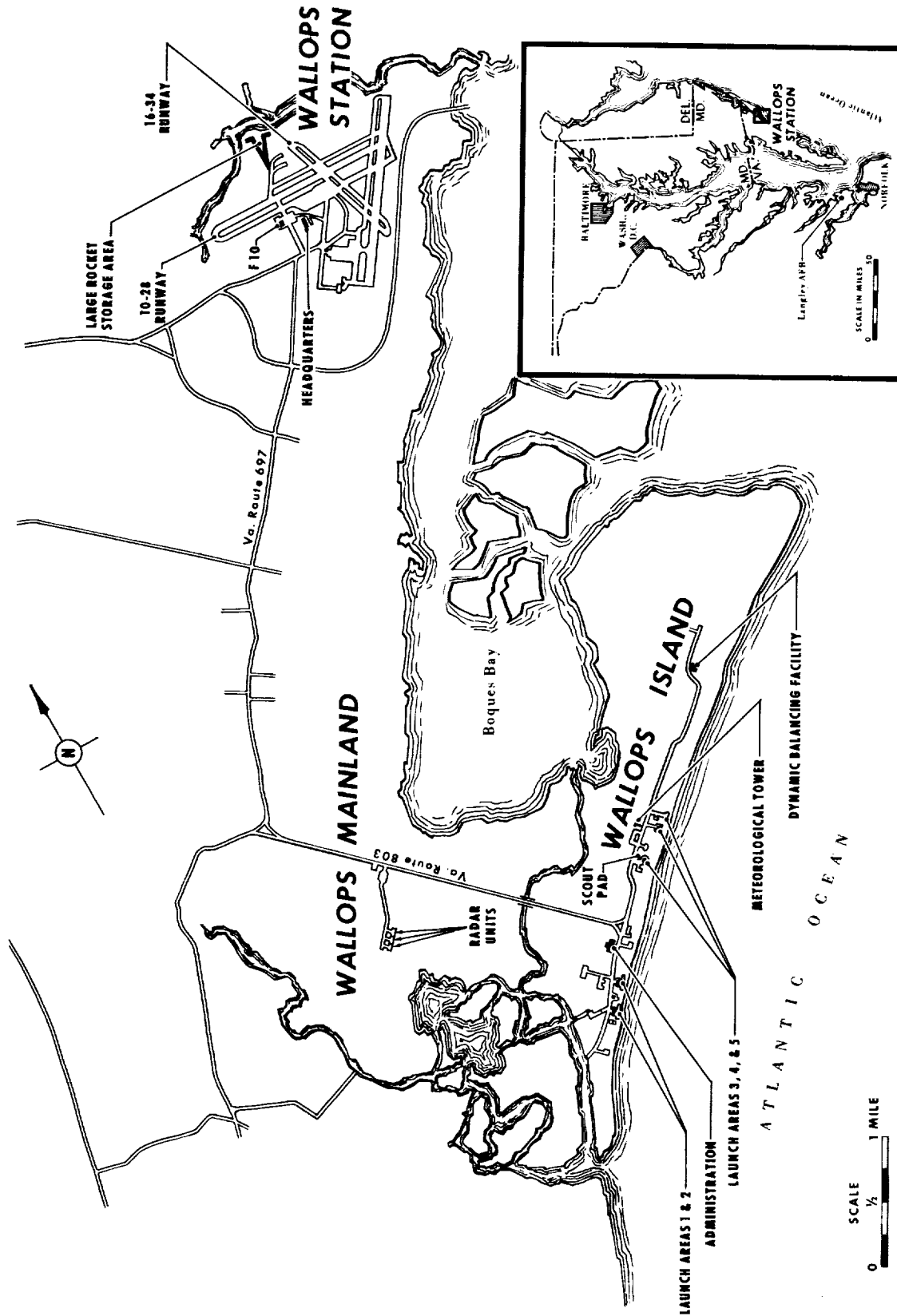

Figure 18 - Wallops Station and vicinity

In addition to a launcher for the Scout vehicle, several launchers for smaller vehicles are also available, plus the usual blockhouses and control centers required for rocket launchings. Limited shop and hangar facilities are also available. A dynamic balance machine for balancing Scout payloads is also installed at Wallops.

Instrumentation of Wallops includes RCA FPS-16, Reeves Mod II, and SCR 584 radars; command destruct transmitters; tracking cameras; radio sonde equipment; and telemetry checkout equipment. Limited mobile equipment for down-range (including shipboard) telemetry is also available. Construction is underway to provide for longer range radars, higher gain telemetry antennas, and long range optical tracking equipment. The mobile down-range telemetry facilities are also being increased.

Coordination with tracking and telemetry facilities operated by NASA on a worldwide basis at locations other than Wallops Island will be arranged for all Scout satellite launchings and for any special projects requiring such additional instrumentation. NASA's policy of cooperation in scientific programs with non-NASA groups has enabled manufacturers, universities, and various government agencies to launch vehicles (or have them launched by NASA) at the Wallops Station.

Atlantic Missile Range

Scout launching capability has been developed for the Atlantic Missile Range by modifying Launch Complex 18A (formerly Vanguard) at Cape Canaveral, Florida. The Vanguard Complex was recently released from NASA control. This capability is under U. S. Air Force jurisdiction and has been developed for the launching by the Air Force of a modified Scout vehicle. It is expected that it will be made available to potential range users upon satisfactory resolution of scheduling, support, and other requirements.

The Scout launch complex will consist of a blockhouse, launch pad, service tower, the associated ground support equipment, and other instrumentation. In addition, complete industrial and logistic support is available from the extensive facility complex at Cape Canaveral. Complete tracking, telemetry and data reduction facilities are also available at the launch site as well as the downrange stations. Recovery facilities can be furnished as required, and augmented if necessary.

Satellites or space probes having missions which require launching in a generally easterly direction are launched from this facility.

Pacific Missile Range

At Point Arguello, California, a Scout launching complex is currently being planned which will use a blockhouse as part of a Probe Launch Complex. Supplementing this

blockhouse, a launch pad and service tower patterned after that now installed at Wallops Station is being funded by NASA for completion in the spring of 1962. Associated ground support equipment is included in this project. Complete industrial and logistic support are available from the range in facilities either completed or under construction.

Range instrumentation for telemetry, tracking, and data reduction is presently available, and is being continually augmented to meet project requirements and to keep abreast of advances in operating procedures and techniques. In addition recovery facilities, consisting of four instrumented ships in service (two now funded and under modification, and two planned) will be made available as required. Supplementary aircraft for recovery missions are also available. Both surface and airborne recovery forces can be quickly augmented by Naval forces if required and available.

Satellites with polar orbital missions and space probes are launched from the facility associated with the Pacific Missile Range. On the other hand, satellites which must be launched towards the east cannot use this facility.

CHAPTER 7

TRACKING

Radio transmitters are installed in satellites or space probes to facilitate space path or orbital determinations and to telemeter scientific data to ground stations. In some applications a single flight transmitter is sufficient for both functions; however, in others it is necessary to use two separate transmitters. Generally, much less power is required for tracking than for telemetering information. If orbital data are required for long periods after the main satellite batteries have ceased to function, or if telemetry data are desired only infrequently, it is usually advisable to use a separate low-power transmitter for tracking.

An additional consideration is the type of ground equipment that is to be used for tracking purposes. Tracking systems employing phase-locked receivers may be seriously affected by the type of modulation used in the telemetering transmitter, while phase-comparison tracking systems may be sensitive to the modulation frequencies used for telemetering data. Therefore, a careful review is required before a final decision is made to use a common transmitter for tracking and telemetering.

In 1959, at the Geneva Conference of the International Telecommunications Union (ITU), the radio frequency bands listed below were allocated for space research.

10.003 to 10.005 Mc
19.99 to 20.01 Mc
39.986 to 40.002 Mc
*136 to 137 Mc
183.1 to 184.1 Mc
400.00 to 401.00 Mc
1427 to 1429 Mc
1700 to 1710 Mc
2290 to 2300 Mc
5250 to 5255 Mc
8400 to 8500 Mc
15,150 to 15,250 Mc
31,500 to 31,800 Mc

*This frequency band will be used by the United States for tracking and telemetry for most earth satellites. Other frequency bands will be used as the need arises.

For those who have not had the opportunity to study the literature in this area, a brief review of tracking methods, facilities and techniques will be helpful at this point. The description is limited to those methods, facilities and techniques which will be available to experimenters using the Scout vehicle for satellite or deep space probe studies. In general, the extensive NASA world-wide system for tracking, which has been established and is presently being enlarged, will be available for such studies.

METHODS

All practical methods of satellite tracking after launching utilize the detection, in some manner, of electromagnetic radiation from the satellite. In general, there are two main methods, radio tracking and optical tracking, with many variations of each. The methods used by the two major NASA supported satellite tracking networks will be discussed and brief mention will be made of the NASA-JPL deep space network. Under special circumstances, arrangements can also be made with the Jodrell Bank Experimental Station in England, to include the 76-meter (250-foot) reflector and associated facilities in the network. This is the largest parabolic reflector presently available for tracking purposes.

Radio Tracking

The methods used in radio tracking fall into four major categories which will be discussed separately.

Radio Interferometers

The radio interferometer measures, by phase comparison methods, the difference in the arrival times of the wave front at two antennas separated by a known distance (in wavelengths). By knowing this separation in wavelengths and measuring the total phase or time difference, direction cosines can be determined (Figure 19). By using two primary multi-wavelength orthogonal baselines, and such shorter baselines for ambiguity resolution as may be needed, two of the three direction cosines of the line to the satellite are determined, thus defining the third direction cosine and the position of the satellite in space.

Subject to possible detailed limitations for any particular orbit, the following general statement can be made: A series of six independent measurements of the direction cosines of lines connecting the various ground stations and the satellite as a function of time, will suffice to allow detailed computation of the orbit. It will be noted that a direct measure-

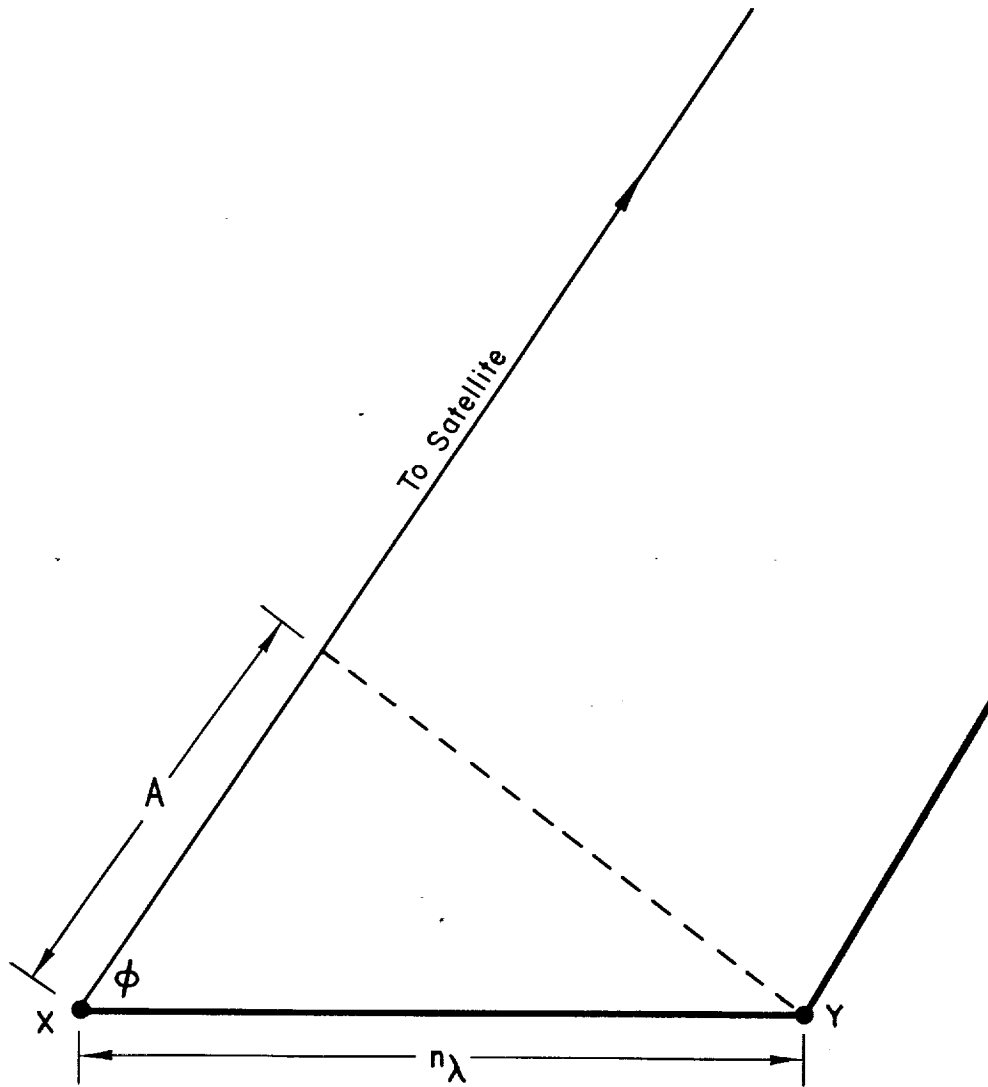

$n\lambda$ = Baseline in wavelengths

A = Total phase difference in wavelengths

ϕ = Angle from baseline to satellite in plane defined by antenna X, antenna Y and satellite antenna

Basic interferometer equation: $\cos \phi = A/n\lambda$

Figure 19 - Basic principle of the radio interferometer tracking system

ment of range is not a necessity. Its use, however, would allow definition of the orbital elements with fewer independent measurements. In its simplest form the interferometer system measures two of the three direction cosines of a line connecting the satellite and the center of the antenna field. Since only a minimal rf beacon is necessary in the satellite, this method of tracking was very attractive when the allowable weight in orbit was limited to the order of 9.1 to 22.7 kilograms (20 to 50 pounds). Not only does this method allow simplicity in the satellite, but it also is capable of yielding accurate results, the principal deterrents to accuracy being refractive effects of the ionosphere and to some extent, the atmosphere. NASA's full-time satellite tracking network utilizes the radio interferometer principle, and has successfully tracked all satellites equipped with a suitable beacon since the start of the satellite program in the United States.

The use of progressively shorter baselines for ambiguity resolutions was mentioned earlier. The number of wavelengths used in the fine-measurement baselines is determined by many considerations; the paramount one is probably the angular resolution desired from the system. This, in turn, is dictated by the probable obtainable accuracy at the operating frequency chosen. For example, with the present 108-Mc system, ionospheric refraction can be corrected for overhead passes to an extent that allows an accuracy of approximately 20 seconds of arc. On this basis, a 4-second resolution is selected which, in turn, dictates approximately a 54-wavelength baseline. Since phase meters repeat every 360 degrees of relative phase, this means that for this particular system there exist 54 positions on each side of zenith that will give identical phase readings. For ambiguity resolution purposes, a ratio of ten in baseline lengths is about the practical maximum. Thus, the system used as an example requires additional baselines of approximately 5λ and approximately $\lambda/2$. Since this particular system utilizes a fan-shaped antenna pattern of approximately 10 by 100 degrees at the 6-db points, it is not necessary to utilize as short a baseline as was indicated above. A single ambiguity channel with a baseline of approximately 7.0 wavelengths is utilized in the narrower dimension, and two baselines of approximately 7.0 and 1.3 wavelengths in the wider dimension.

Additional information on the radio interferometer method of satellite and space probe tracking can be found in References 1, 2, and 3.

Radar

A description of radar tracking is not included in this document; however, it should be pointed out that a beacon (radar transponder) is usually required in satellite applications. No estimate of the ultimate angular accuracy of this system is given, other than that it probably is not capable of interferometer accuracies. But radar tracking does have the

important advantage of providing range information. In most cases, precise radar tracking is used for the launching sequence, not for general satellite tracking. Although some high-power long-range radars are capable of tracking satellite-sized objects, they do not in general deliver precise angular information as compared with the radio interferometer system.

Up to the present time it has been impractical to install a satisfactory radar beacon in most satellite or probe payloads because of the weight-power requirements. The same limitations probably will limit the use of radar beacons in payloads launched by the Scout vehicle

Doppler

Doppler tracking can be used to determine the trajectory to and somewhat beyond injection into orbit, as well as to determine the orbital elements. The former application has been made in the Juno II Explorer series, while some experience has been obtained with the latter on Explorer IV and the Transit program.

Experimental results indicate that the Doppler data may be sufficient to compute the period within 1 second and site with an accuracy of 0.2 percent. On Explorer IV the observed doppler shift of a fixed-frequency transmitter was utilized for tracking. This technique employed simultaneous triangulation on the satellite from different stations. The radial range between the satellite and the station was obtained by measuring the slope of the doppler shift, and proper use of this radial range permitted approximate location of a satellite pass. A technique of plotting the times of successive passes on successive days proved to be more accurate. However, the computer program described in the following paragraphs is more accurate than either of these methods.

A signal from a source traveling in a straight trajectory produces a doppler shift from which precise measurements of range and velocity can be made. A straight trajectory is, however, only an approximation of the local behavior of the orbit. Use of the exact doppler equation, in which the eccentricity of the orbit and the rotation of the earth are included, produces such complex equations that they are difficult to interpret. If a circular orbit is assumed, fairly good expressions can be derived to approximate the satellite's velocity and range. On the basis of limited success in doppler tracking, a digital computer program has been developed to eliminate some of the difficulties. This program determines orbit parameters and the effective mean frequency of the satellite transmitter, and these parameters are then used to produce an ephemeris for ascending and descending horizon times and the doppler inflection time (time of nearest approach). The ephemeris gives the apparent frequency of the satellite, its latitude and longitude, range, altitude, and elevation angle.

Automatic Tracking Antenna Systems

Most of the common types of automatic tracking antenna systems employ a multiple feed in a parabolic reflector and, by phase-comparison methods, derive an error signal in two axes which allows the antenna to track the signal once it is acquired. The larger and more sophisticated units can approach angular accuracies in the order of 1 to 2 minutes of arc under favorable conditions. It is unlikely that ultimate accuracies much better than this will be attained. However, the units are usually capable of near horizon-to-horizon coverage and, therefore, give a relatively long readout to which the various smoothing techniques can be applied.

The NASA-JPL deep space network is an example of the use of this type of antenna. The installation at Goldstone has given excellent results both in tracking space probes and for certain satellite applications. This type of antenna is almost a necessity for certain wide-band data acquisition uses. An automatic tracking antenna using an array of yagi elements is being developed for data acquisition applications in the 136-Mc band, and will eventually be installed at all Minitrack stations. In this case the beamwidth will be about 17 degrees and the gain about 20 to 21 decibels.

Optical Orbit Determination

The primary purposes of orbit determination by optical means are: (1) certain experiments requiring higher precision than is obtainable with radio tracking methods; (2) the observation of objects without radio tracking aids; and (3) a backup to other methods.

At present, all optical sighting requires that sunlight illuminate the satellite while the local sky is in either morning or evening twilight. This, in addition to the requirement for good weather, poses severe limitations on the amount of data obtainable from an optical tracking system. An astrographic camera, photographing the satellite against a star background, can yield angular measurements accurate to 1 to 3 seconds of arc. Photographic techniques are limited in accuracy owing to difficulty in obtaining and correlating time markers with sufficient precision, and to difficulty in relating these markers to a common time standard. Eventual developments in electronic detection of optical images, or a satellite flashing light system, may solve this timing problem. Although reading of the plates is laborious and time consuming, automation is now simplifying this procedure.

So many different forms of telescopes and camera combinations have been used that no attempt will be made here to classify the methods as was done in the case of radio tracking. Two basic systems may be used: one employs fixed cameras and the second employs moving cameras which follow the satellite.

TRACKING FACILITIES

Radio Tracking

A number of different radio tracking facilities have been used in combination for various satellite launchings. Some of these facilities were designed for other purposes and are available on a part-time or special purpose basis only - for example, the station at Jodrell Bank, England. Others are integral parts of Military test ranges or tracking networks. This discussion will be limited to the two full-time NASA Radio Tracking Networks, The NASA-Goddard Minitrack and the NASA-JPL Deep Space Network, particularly since these facilities will be the prime tracking systems for Scout launchings.

NASA-Goddard Minitrack System

At the present time ten stations comprise the basic Minitrack network. This network has been in operation since late 1957, and has tracked all U. S. satellites carrying the basic 108-Mc beacon. The operating principle of a radio interferometer was outlined in the discussion of methods of radio tracking, and mention was made of the use of a very light low-powered transmitter in the satellite as the source of electromagnetic radiation for this method. The initial Minitrack system, (References 1 and 2) employed a basic ground antenna with a fan-shaped beam of approximately 10 by 100 degrees. The arrangement of these antennas is shown in Figure 20. The ambiguity antennas utilized in this system consisted, essentially, of 1/2 of the basic antenna. Since only four slot elements are used compared to eight in the basic antenna, the result is a wider beamwidth in the narrow dimension of the beam and an approximate reduction of 3 decibels in gain. The fine baselines are approximately 55 wavelengths, the east-west ambiguity baselines 7.0 wavelengths, and the north-south ambiguity baselines approximately 7.0 and 1.3 wavelengths. This arrangement gives very good coverage and adequate ambiguity resolution for low orbital inclinations. For high-inclination satellites (50 degrees or more), the orientation of the beam is unsatisfactory; a proposed solution to this problem will be discussed shortly. The maximum resolution of the system is 4 seconds of arc, and the maximum accuracy under ideal conditions is 20 seconds of arc.

The signals from the two antennas at the ends of a given baseline are first amplified by preamplifiers and then translated and combined in a linear (Reference 4) manner by the so-called "special local oscillator technique". In this technique the signal from one antenna of a pair is mixed with one output from the direct local oscillator, and the signal from the other antenna is mixed with another output of this oscillator which is phase-locked a fixed (reference) frequency away from the first local oscillator output. The reference frequency is, in turn, derived from the time standard. This allows amplification of both signals in a common channel. Next, the relative phase information which

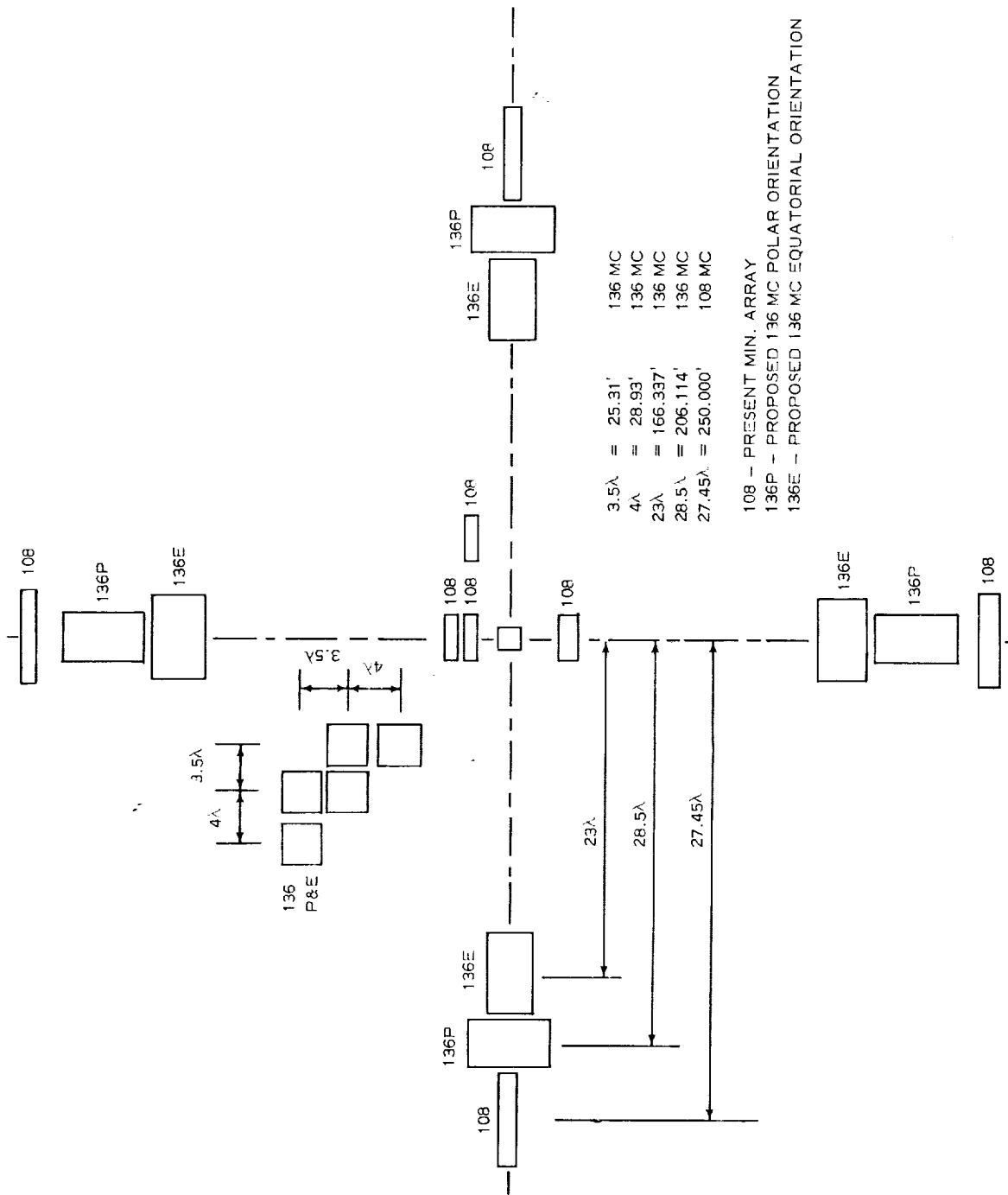

Figure 20 - Combined Minitrack antenna field

existed at the two antennas is obtained by comparing the phase (Reference 5) of the reference signal and the detected beat of the two antenna signals after they are combined in a simple adder circuit. The relative phase of the detected signal and the reference signal are compared by analog and digital type phase meters. Both types of information are recorded by 8-channel strip chart recorders.

Standard time (Reference 6) at a station is maintained by a precision oscillator (Western Electric 076A/U or Hermes 101-C) and the necessary countdown digital clock, etc. All measurement frequencies at the station are derived from the time standard, and the read-out of the digital phase meter is triggered by the time standard. The tie of the data read-out to the time standard is accurate to within 100 microseconds, and the tie to WWV is accurate to an order of ± 1 to ± 2 milliseconds, depending upon the location of the station.

The following will serve to outline the present status of the network. As has been noted, the operating frequency for the system will change in the near future. New stations are being added at selected locations to cover higher inclination and polar launches, and ten stations will have antenna arrays arranged for both high and low orbital inclination launches. (Two sets of fine antennas will be available at these stations. These will be set up for the east-west direction in one case and for the north-south in the other). Detailed antenna arrangements are given in Figure 21 and in Table 6. Additional information is available in References 5 and 6.

The original Minitrack network consists of ten stations equipped with precision interferometer tracking systems operating at 108 Mc. All of these stations also are equipped to receive telemetry on 108 Mc. In addition, most of these stations are equipped to operate (tracking and telemetry) in a 1-Mc band between 136 and 137 Mc as well as at 108 Mc. Four new stations have been or will be added to the network, one operation on both the 108- and 136-Mc bands and three on the 136-Mc band only. Table 6 lists the stations and their present and future capabilities, and Table 7 gives the geodetic positions of the stations. Present plans are that all stations be fully operational at the new frequency by the fall of 1961.

Since it is part of the station equipment, the telemetry receiving (data acquisition) equipment will be discussed briefly here, but in more detail in the next chapter. Present receivers at 108 Mc are limited to a maximum bandwidth of 30 kc. An interim receiver will be furnished having several i. f. bandwidths up to 200 kc, and the receiver to be installed for the 136-Mc band will have several i. f. bandwidths up to 1 Mc. Both the tracking and the telemetry receivers to be installed for use in the 136-137-Mc band will be completely crystal-controlled and will be tunable in 1-kc steps over the 1-Mc band. Provision will be made to go detect am and fm signals at each bandwidth, or to translate the signal for direct recording or use with a tracking filter (correlation detection). In addition, provision will be made for precision Doppler measurement as an auxiliary output of this receiving system.

Table 6
Present and Future Minitrack Station Capabilities

Station Location	Operation Date	136-137-Mc Capability (Track. & Telem.)	108-Mc Capability (Track. & Telem.)	Low-Orbital-Incl. Ant. Orient.	High-Orbital-Incl. Ant. Orient. (136-137-Mc Only)
Blossom Point, Md.	Present	Present	Present	Present	Present
Ft. Myers, Fla.	Present	Present	Present	Present	None
Antigua, W.I.F.	Present	None	Present	Present	None
Quito, Ecuador	Present	Present	Present	Present	Present
Lima, Peru	Present	Present	Present	Present	None
Antofagasta, Chile	Present	Present	Present	Present	None
Santiago, Chile	Present	Present	Present	Present	Present
Woomera, Australia	Present	Summer '61	Present	Present	Summer '61
Esselen Pk., So. Africa	Present	Summer '61	Present	Present	Summer '61
San Diego, Calif. *	Present	None	Present	Present	None
St. Johns, Newf.	Summer '61	Summer '61	Summer '61	Summer '61	Summer '61
E. Grand Forks, Minn.	Present	Present	None	Present	Present
Fairbanks, Alaska	Fall '61	Fall '61	None	Fall '61	Fall '61
Winkfield, England	Present	Present	None	Present	Present
Goldstone Lake, Calif. †	May '61	May '61	None	May '61	May '61

* Station to be relocated to Goldstone Lake, California

† Replace San Diego Station

Table 7
Geodetic Positions of Minitrack Stations

Station Designation & Location	Geodetic Position		Elevation	
	East Longitude	Latitude	Meters	Feet
BPOINT Blossom Point, Maryland	282 54 48.170	38 25 49.718N	4.6	15
FTMYRS Fort Myers, Florida	278 08 03.887	26 32 53.516N	3.4	11
PANTIG Antigua, W. I. F.	298 13 16.536	17 08 32.586N	4.9	16
QUITOE Quito, Ecuador	281 25 14.770	00 37 21.751S	3567	11,703
LIMAPU Lima, Peru	282 50 58.184	11 46 36.492S	49.1	161
AGASTA Antofagasta, Chile	289 43 36.838	23 37 15.993S	519.1	1703
SNTAGO Santiago, Chile	289 19 51.283	33 08 58.106S	694.9	2280
OOMERA Woomera, Australia	136 46 59.520	31 06 09.498S	155	510
JOBURG Esselen Park, So. Africa	028 14 28.376	26 01 56.845S	1637	5370
NELCAL San Diego, California	243 01 43.707	32 34 47.701N	157	514
NEWFLD St. Johns, Newfoundland	307 16 43.240	47 44 29.049N	122	400
EGRFKS E. Grand Forks, Minnesota	262 59 21.556	48 01 20.668N	251	823
ALASKA Fairbanks, Alaska	212 09 47.387	64 52 18.591N	161	527
WNKFLD Winfield, England	359 18 14.615	51 26 44.122N	66	215
----- Goldstone Lake, California	243 6 2.776 (Approx.)	35 19 48.525N (Approx.)	-	-

The telemetry antenna system will be either a hand-directed or self-tracking Yagi array with gains of from 18 to 22 db. Provision will be made for polarization diversity by using orthogonal sets of elements in each section of the array.

Each of the tracking stations is in continuous teletype contact with the Space Control Center (SPACECONN) at the Goddard Space Flight Center. The communication system is described in more detail in Chapter 10. Tracking data are, at present, manually read from the records, tabulated at each station in the proper format, and transmitted to the Control Center. There it is reviewed for communication or procedural errors and then sent on to the Computing Center for conversion to punched cards and use in orbital computations. Equipment has been developed to punch the tracking data automatically on teletype tape. This equipment is undergoing field evaluation and is expected to be produced for station use by mid-1961.

NASA-JPL Deep Space Network

The deep space network (References 7 and 8) is intended primarily for probe and deep space tracking, and only a brief outline of the facilities will be given here. However, the network may be very useful for special problems, and additional detailed information is available from the Office of Space Flight Programs, Assistant Director for Space Flight Operations, NASA Headquarters. The network will consist of antenna installations at Goldstone Lake, California (East Longitude 243-09, North Latitude 35-23-24), near Woomera, Australia (East Longitude 136-46-59, South Latitude 31-06-09) and Hartebeesthoek, South Africa (East Longitude 27-55, South Latitude 25-55). The Goldstone facility is in operation, the Woomera installation is essentially complete, and the South African station should be completed sometime in 1961.

The basic antenna used in this network is a Blaw-Knox 26-meter (85-foot) parabolic reflector ($F/D = 0.41$) on a polar mount. Hour angle position from 90 to 270 degrees, and declination from the local horizon to Polaris, can be read to an accuracy of 1 milliradian. Tracking rates up to one degree per second are currently available, and it is planned to operate the antenna at frequencies up to 2400 Mc.

Table 8 gives the feeds presently available at the Goldstone installation. All linear feeds can be rotated by means of synchros to compensate for the Faraday effect. Radio frequency mixing is done at the focal point and the signal is brought down through Heliac cables and amplified. At 960 Mc, the half-power width of the sum pattern of the monopulse antenna feed is 0.7 degree.

Table 8
Tracking Feeds at the Goldstone Facility

Frequency (Mc)	Application	Polarization	Beamwidth (degrees)	Function
108*	Satellite	Linear	10	4-dipole monopulse
108*	Satellite	Rt-circular	10	4-dipole monopulse
378	Probe	Rt-circular	2.5	4-dipole monopulse
378	Probe	Linear	2.5	4-dipole monopulse
960	Lunar & Deep Space	Rt-circular	1	4-turnstile monopulse
960	Lunar & Deep Space	Circular	1	Listening feed
2390	Echo	Variable	0.5	4-horn monopulse

*To be replaced with 136-137-Mc system in 1961.

Microlock Stations

The Microlock stations are portable and are used chiefly for orbital injection data. They can also be used for telemetry. Use of the stations and locations available for Scout launchings must be coordinated in advance of an operation to avoid interference with other programs.

The Microlock stations are high-sensitivity Doppler tracking stations using phase-lock receivers equipped for 108 and 960 Mc operation. These receivers have sensitivities of 150 dbm and provide limited telemetry receiving capability with a bandwidth of 10 cps. Approximately six of these portable stations will be located in the eastern United States.

Optical Orbit Determination

The major optical tracking network used in conjunction with NASA-sponsored projects is the Baker-Nunn Camera Network of the Smithsonian Astrophysical Observatory. In addition, two volunteer amateur organizations participate in making optical observations.

Smithsonian-NASA Baker-Nunn Camera Network

This network consists of a worldwide distribution of optical tracking stations employing a type of camera (Reference 9) specifically designed for satellite tracking. The

station locations are given in Table 9. In addition, each station is equipped with a precision time standard. As in the case of the Minitrack Network, time standard accuracy is limited by propagation delay variations from the reference station (U. S. National Bureau of Standards Station WWV) and not by the equipment at the station.

The following briefly describes some major technical details of the Baker-Nunn Camera. The camera utilizes a 51-centimeter (20-inch) achromatic three-element corrector plate and a 79-centimeter (31-inch) spherical mirror. Its focal ratio is F/1 and the scale is approximately 406 seconds of arc per millimeter. Measurement accuracies of 2 to 6 seconds of arc have been achieved. Although the designed timing precision of 1 to 2 milliseconds is being achieved at several stations, others may require modifications to achieve this precision.

The camera has a field of view of 5 by 30 degrees, which is photographed on a strip of 55-mm film about 0.3 meters (1 foot) in length. Provision is made in the mount to orient the long axis of the film along the expected satellite path. The camera can be adjusted to track alternately at the approximate satellite rate and at the sidereal rate parallel to the satellite orbit. Two shutters are used: a clamshell to begin and terminate each exposure, and a barrel shutter to provide the necessary sharp breaks in the trail for measurement and timing reference. The camera operates on a basic time cycle whose length may be

Table 9
Location of Smithsonian Baker-Nunn Optical Tracking Stations

Station	East Longitude	Latitude	Altitude	
			Meters	Feet
Curacao Island, N. W. I.	291 09 46.00	12 05 50.40N	12	39
Jupiter, Palm Beach, Florida	279 53 12.92	27 01 13.00N	12	39
Maui, Hawaii	203 44 23.40	20 42 36.00N	3048	10,000
Naini-Tal, India	079 25 54.00	29 21 32.00N	1924	6,313
Organ Pass, New Mexico	253 26 51.74	32 25 24.25N	1651	5,417
Arequipa, Peru	288 30 31.48	16 27 43.82S	2452	8,045
Shiraz, Iran	052 31 33.75	29 38 40.18N	1596	5,236
S. Fernando, Cadiz, Spain	353 47 36.86	36 27 33.83N	24	79
Tokyo, Japan	139 32 28.22	35 40 11.08N	58	190
Villa Dolores, Argentina	294 53 18.30	31 56 08.30S	598	1,960
Olifantsfontein, South Africa	028 14 53.91	25 57 33.85S	1544	5,066
Woomera, Australia	136 46 54.70	31 06 06.20S	162	532

set at 2, 4, 8, 16 or 32 seconds. The sensitivity is such that photographs have been obtained of the 15-centimeter (6-inch) Vanguard satellite at 3860 kilometers (2400 miles), and the black painted Explorer VI satellite at 20,900 kilometers (13,000 miles).

Depending on operational priority, one or more field reductions are made of each transit successfully photographed. This field reduction requires about one hour and fifteen minutes and yields a precision of about seven minutes of arc and 0.01 seconds of time. The full-precision reduction is achieved at Cambridge, Massachusetts; where precision measuring engines equipped with automatic digital data readout and card punching are available and high-capacity photoreduction is performed. A reduction capability of nearly 800 observations per month is anticipated.

Project Moonwatch

Project Moonwatch (Reference 10), under the direction of the Smithsonian Astrophysical Observatory, makes use of many teams of amateur astronomers and can be used to supplement the Baker-Nunn camera network. A team is composed of approximately 15 persons, each equipped with binoculars or small telescopes aligned with overlapping fields. Passage of a satellite through the station meridian will be observed by at least one person. The observer marks the instant of meridian passage and notes approximate zenith angle by comparison to the star background. The accuracy obtained with this system is in the order of 1 second of time and 1 degree of arc. This is sufficient for crude orbital computations; however, the greatest utility of the system is in acquiring satellites which do not transmit a radio signal, or in obtaining data on the re-entry phase for various satellites.

Volunteer Photographic Tracking (Phototrack)

The Phototrack project, under the direction of the Society of Photographic Scientists and Engineers, makes use of large-aperture fixed cameras, principally surplus aerial cameras. In addition to the limitations imposed upon Baker-Nunn observations, the fixed cameras can obtain data only on bright objects owing to the somewhat slower lens and the fact that the camera is not tracking. However, for satellites bright enough to make a trace, data with precision comparable to that of the Baker-Nunn camera can be obtained, subject to timing limitations.

Future Optical Facilities

Special preparations are being made for the possibility of a flashing-light geodetic satellite. In addition, consideration is being given to photoelectric detection, to real-time optical equipment, and to possible deep-space optical requirements.

ORBITAL DETERMINATION

The orbital determination procedures have been well documented and described in References 11, 12 and 13. It is sufficient to state here that a number of formats for the presentation of orbital data have been developed. The experimenter should state his needs for detailed orbital information at the earliest possible date to see whether or not available formats will satisfy his needs. This should be done through the cognizant group in NASA. Initial correspondence can be directed to the Director, Office of Space Flight Programs, NASA, Washington 25, D. C.

REFERENCES

(Chapter 7)

1. Mengel, John T., "Tracking the Earth Satellite, and Data Transmission by Radio," Proc. IRE 44(6):755-760, June 1956
2. Mengel, John T., "Minitrack System Design Criteria," Electrical Engineering, 76(8): 666-672, August 1957
3. Easton, R. L., and Fleming, J. J., "The Navy Space Surveillance System," Proc. IRE 48(4):663-669, April 1960
4. Simas, V. R., and Bartholomew, C. A., "Receiver System," U. S. Naval Research Laboratory Report No. 5055, Project Vanguard Report No. 23, Minitrack Report No. 3, December 6, 1957
5. Schroeder, C. A., Looney, Jr., C. H., and Carpenter, Jr., H. E., "Phase Measurement," U. S. Naval Research Laboratory Report No. 4995, Project Vanguard Report No. 18, Minitrack Report No. 1, July 26, 1957
6. Schroeder, C. A., Habib, E. J., and Silvester, W. R., "Time Standard," U. S. Naval Research Laboratory Report No. 5227, Project Vanguard Report No. 36, Minitrack Report No. 8, October 22, 1958
7. Rechtin, Eberhardt, "Communication Techniques for Space Exploration," Institute of Radio Engineer Transactions on Space Electronics and Telemetry, Set 5, No. 3, September 1959, pp. 95-98

8. Hall, J. R., "A Description of Deep Space Net Facilities, Operations, and Capabilities," Jet Propulsion Laboratory Publication 30-21, Pasadena, California, December 4, 1959
9. Henize, Karl G., "The Baker-Nunn Satellite Tracking Camera," Telescope 16 (3): 108-111, January 1957
10. Smithsonian Astrophysical Observatory, "Bulletin for Visual Observers of Satellites, No. 1," Sky and Telescope 15(9):4, July 1956
11. Siry, J. W., "The Vanguard IGY Earth Satellite Program," Fifth General Assembly of CSAGI, Moscow, 1958
12. Theory and Analysis Staff, Goddard Space Flight Center, "Interim Definitive Orbit for the Satellite 1959 Alpha, Vanguard II," NASA Technical Note D-411, 1960
13. Carr, Russell E., and Hudson, Henry R., "Tracking and Orbit Determination Program of the Jet Propulsion Laboratory," Jet Propulsion Laboratory Technical Report No. 32-7, Pasadena, California, February 22, 1960

CHAPTER 8

TELEMETRY

All of the experimental information obtained from a non-recoverable satellite or a space probe, except for those limited experiments which derive data from variations in orbital parameters, must be returned to earth through some form of radio telemetry link. (The radio frequency bands allocated by the International Telecommunications Union (ITU) meeting in Geneva in 1959 were listed in Chapter 7.) A wide variety of systems and components have been developed specifically for space operations. In the interest of reliability and operating efficiency, most of these depend almost entirely upon the use of solid state devices including transistors and magnetic core units. Flight equipment should be kept as simple as possible even at the expense of complicating the ground facilities, since only the latter are accessible for test and maintenance. In the pages which follow a number of telemetry methods are reviewed, and specific details of several systems which have been successfully used for satellite and space probe data transmission are given.

METHODS

Standards

Activity associated with telemetry necessarily increased sharply with the beginning of rocket research. With the growth of the guided missile development program, the field of telemetry expanded to the point where the Committee on Guided Missiles of the Research and Development Board (RDB) of the Department of Defense, in 1948 established standards pertaining to such parameters as frequency, bandwidth, multiplexing, accuracies, etc. These standards were revised and extended as necessary thereafter, as a result of periodic reviews by the Committee's Working Group on Telemetering, Panel on Test Range Instrumentation. The last official RDB revision of the standards was published as RDB Report MTRI 204/6, dated November 8, 1951.

With the termination of the Research and Development Board organization, the Inter-Range Instrumentation Group Steering Committee (IRIG) under the Department of Defense has assigned the task of promulgating new or revised standards to the Inter-Range Telemetry Working Group (IRTWG). IRIG Document No. 103-56 (Reference 1) resulted from this assignment. This document, which may be obtained by addressing an inquiry to the IRIG Secretariat, White Sands Proving Ground, New Mexico, U. S. A.

explains the frequency-division multiplex type of radio telemetry wherein an rf carrier is modulated by a group of subcarriers, each having a particular center frequency. The pulse-duration modulation system (PDM) is also discussed, along with anticipated revisions and some changes that are presently being considered.

Telemetry associated with satellites and space probes is subjected, in general, to conditions which differ from those characterizing the guided missile testing program. Thus, an effort is being exerted by experimenters, instrumentation groups, ground receiving and recording organizations, and data processing groups associated with the NASA to standardize telemetry methods associated with the activities pursued by this agency. A set of standards for satellites and space probes will enhance the compatibility between satellite and ground receiving instrumentation and, of equal importance, will result in a determination of optimum systems design for particular experimentation. It appears, however, that such standardization is still somewhat in the future.

Multiplexing Techniques

Radio telemetry associated with space activities normally requires the transmission of many channels of information. Almost without exception it is impractical and inefficient to employ a separate rf data link for each channel. The process of transmitting more than one channel over one data link is called multiplexing. Although multiplexing has the possible disadvantage of introducing a form of noise called crosstalk between channels, the effects from this factor can be reduced to the vanishing point by proper design of the equipment. Two general methods of multiplexing are in use: frequency division (the use of subcarriers), and time division (commutation).

A frequency division system uses a separate subcarrier frequency for each channel. These subcarriers are spaced far enough apart to ensure that the sideband structure of each channel does not overlap into the frequency interval allotted to the adjacent channels. The information to be telemetered is generally converted by the transducer to a varying voltage which modulates the frequency or amplitude of the subcarriers. These are then added linearly into one electrical signal which modulates the carrier. At the receiving end, the modulated subcarriers are separated by frequency selective circuits (after demodulation of the rf carriers). The individual subcarriers are then demodulated by frequency discriminators, or amplitude demodulators, and are recorded or displayed by visual analog recorders, digital printing devices, or magnetic tape recorders.

Time division multiplexing, instead of allotting a separate band of frequencies to each channel, allots time periods in cyclical sequence. That is, the information in each channel is sampled by a commutator in a periodic cyclic sequence so that a modulated pulse is generated for each channel. These modulated pulses of electrical energy control the amplitude or frequency of a single carrier. It is customary to provide synchronizing pulses between frames so that the observer or automatic decommutating equipment can properly channel each segment of information to the proper point.

Sometimes a requirement is fulfilled by a combination of both frequency and time division multiplexing. The most common system in use at this time is frequency division multiplexing of the carrier and time division multiplexing of one or more of the subcarriers. In this way the telemetry system is adaptable for both wide band (rapidly varying) data and narrow band (slowly varying) data.

Present telemetering systems for satellite data utilize various combinations of amplitude modulation (AM), frequency modulation (FM), phase modulation (PM) and pulse code modulation (PCM). In the system illustrated in Table 10, information is conveyed by: (1) the burst length; (2) the frequency contained in the burst; and (3) the duration of the interval between bursts. Thus, with three variables for each pulse, 48 separate channels of information are possible. Table 10, taken from References 2 and 3, illustrates how these channels might be assigned in a typical satellite application.

Space Vehicles as Radio Frequency Sources

At this time and within the immediate future, the total allowable weight of the payload used in the conduct of space science experiments will be quite restricted. As a result the various experiments, telemetry systems, and power supplies used in such payloads will have to be designed to carry out their functions with minimum weight and power consumption.

The antenna systems on satellites and space vehicles can be designed to transmit either linearly or circularly polarized radio waves. The highest signal-to-noise ratios at the ground stations are obtained when the incident radiation is aligned with the polarization of the antenna. However, because the space vehicle or satellite often rolls and tumbles in its flight, severe decreases in the received signal levels result when the aspect of the satellite is such that its radio waves arrive with their polarization at right angles to that of the ground antenna. Thus, it is the consensus among radio engineers that it is most advisable to transmit the energy with circular polarization and to receive with linear polarization, or vice versa. In this way a 3-db penalty is accepted in order to avoid severe data drop-outs. If true isotropic radiation could be maintained, the received signal level would remain constant regardless of the vehicle's rotations. Actually, it is not within the present state of the art to design vehicle antenna systems having true isotropic characteristics for either linear or circular polarizations. In addition, as perfectly circular polarization occurs at only some vehicle aspect angles, the polarization is in general elliptical, changing to circular or linear at other aspect angles. Despite these variations, the frequency and depth of the decreases in the received signal levels are generally significantly less for telemetry systems employing a combination of circularly and linearly polarized antennas. An evaluation of data taken by the Minitrack network indicates that the received signal variations from most satellites transmitting elliptically polarized signals and received by linear polarized ground antennas are reasonable. (Approximately 75 percent of the time the level of the received

Table 10
Telemetry Channel Assignments for Lyman-alpha Environmental Satellite

High Frequency Burst		Burst Duration		Interval Between Bursts	
Channel	Function	Channel	Function	Channel	Function
A	Instan. Lyman-alpha	A1	Polar erosion A	A2	Battery volts
B	Solar aspect	B1	Differ. pressure	B2	Short calibrate
A	Instan. Lyman-alpha	A1	Polar erosion A	A2	Battery volts
B	Solar aspect	B1	Differ. pressure	B2	Short calibrate
A	Instan. Lyman-alpha	A1	Polar erosion A	A2	Battery volts
B	Solar aspect	B1	Differ. pressure	B2	Short calibrate
C	Meteor count, units	C1	Long calibrate	C2	Battery volts
D	Meteor counts, tens	D1	Package temp.	D2	Polar skin temp.
A	Instan. Lyman-alpha	A1	Polar erosion A	A2	Battery volts
B	Solar aspect	B1	Differ. pressure	B2	Short calibrate
A	Instan. Lyman-alpha	A1	Polar erosion A	A2	Battery volts
B	Solar aspect	B1	Differ. pressure	B2	Short calibrate
A	Instan. Lyman-alpha	A1	Polar erosion A	A2	Battery volts
B	Solar aspect	B1	Differ. pressure	B2	Short calibrate
E	Meteor count, hundreds	E1	Polar erosion B	E2	Equator skin temp.
F	Peak Lyman-alpha	F1	Equator erosion	F2	Cadmium sulfide cell

signal shows less than 6 db reduction below the maximum level.) This study takes into account not only level reductions due to cross-polarization effects, but also those due to the directive radiation pattern of the satellite.

From the plots of attenuation versus distance for various frequencies (Figure 21) it may be noted that the free-space transmission loss at a given frequency increases 20 db per decade of distance. Also, the transmission loss at a given distance increases 20 db per decade of frequency. The loss values are calculated for an isotropic antenna at the transmitter and at the receiver. The gain (referred to isotropic) of both receiving and transmitting antennas can be added to the loss values given, thus providing the net transmission loss.

A common method of achieving circular polarization is to employ a so-called turnstile antenna arrangement. This arrangement has excellent characteristics with regard to optimizing the isotropicity of the radiation when the satellite or vehicle is not large with regard to the wavelength of the radio waves employed. When the basic structure is large with respect to the wavelength radiated, the various elements of the antenna array become electrically disassociated if placed symmetrically about the body. In that case the types of antenna systems which must be employed will display radiation patterns accompanied by severe nulls.

The required radiated power could be materially reduced if concentrated in a beam oriented in the direction of the ground station. However, satellites containing stabilization systems will not be available for Scout experimenters in the immediate future; thus there is no alternative but to provide isotropic radiation and to accept the waste resulting from power radiated in directions other than useful ones. Fortunately, in the larger vehicles of the future it may be possible to include aspect stabilization, so that a directive antenna beam rather than isotropic radiation may become feasible.

Signal and Noise Levels

The level of the signals arriving at the receiving antennas must exceed the noise power by a sufficient margin to allow extraction of the telemetered information. The noise power received is a function of the receiver bandwidth, which is usually just sufficient to accommodate the frequency sidebands on the telemetry carrier. The amount by which the signal must overwhelm the noise varies considerably depending upon post-detection filtering in the receiving equipment; the desired accuracy of measurements; the methods of modulation, multiplexing, and coding; the information rates involved; and other considerations.

There are several sources of the random fluctuations commonly called "noise" in the output voltages of high gain receivers. This "noise" appears to emanate from colliding galaxies; from unstable stars which are in an extremely turbulent electrical state; from extremely active, turbulent gaseous clouds which are associated with fluctuating

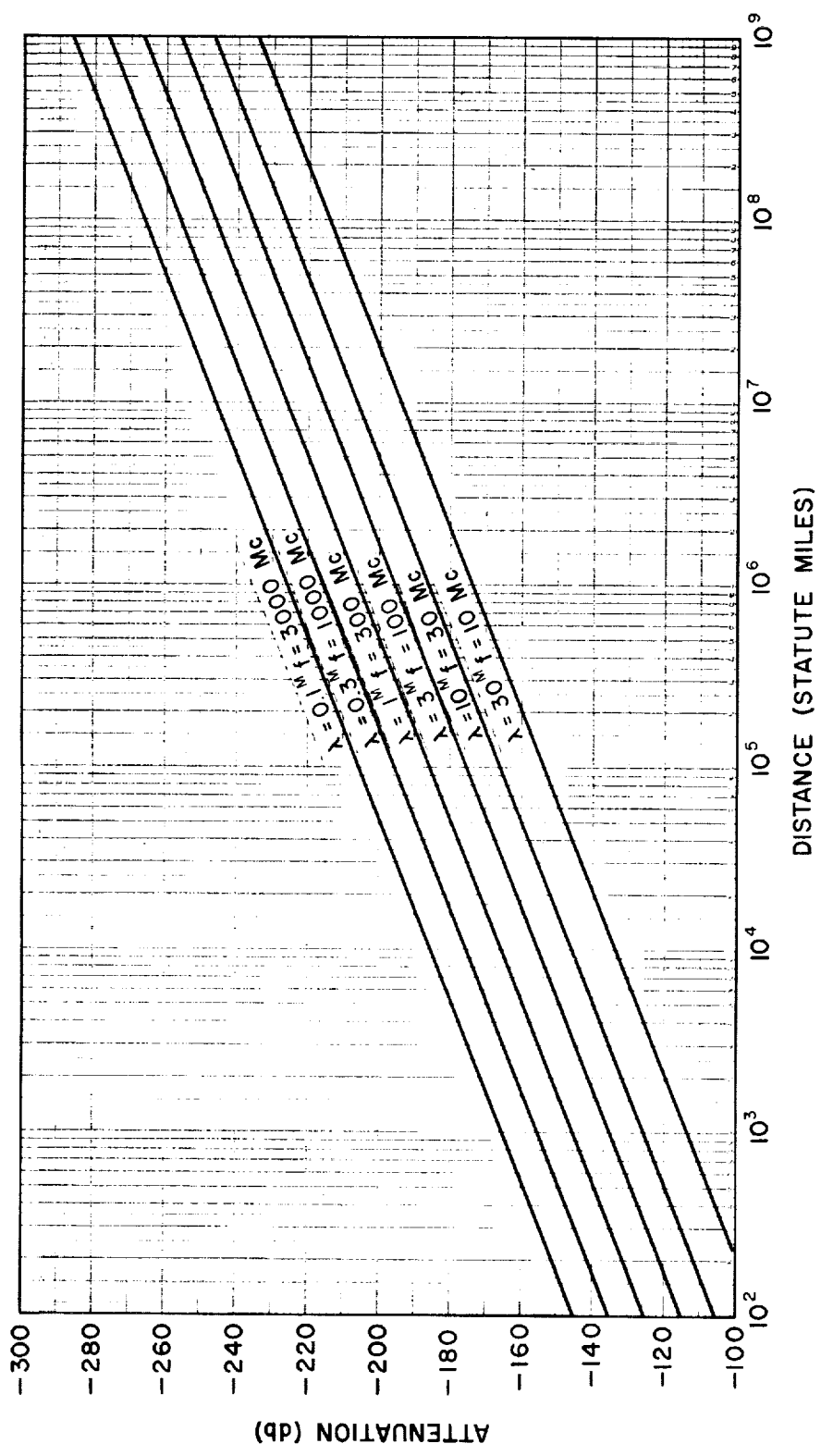
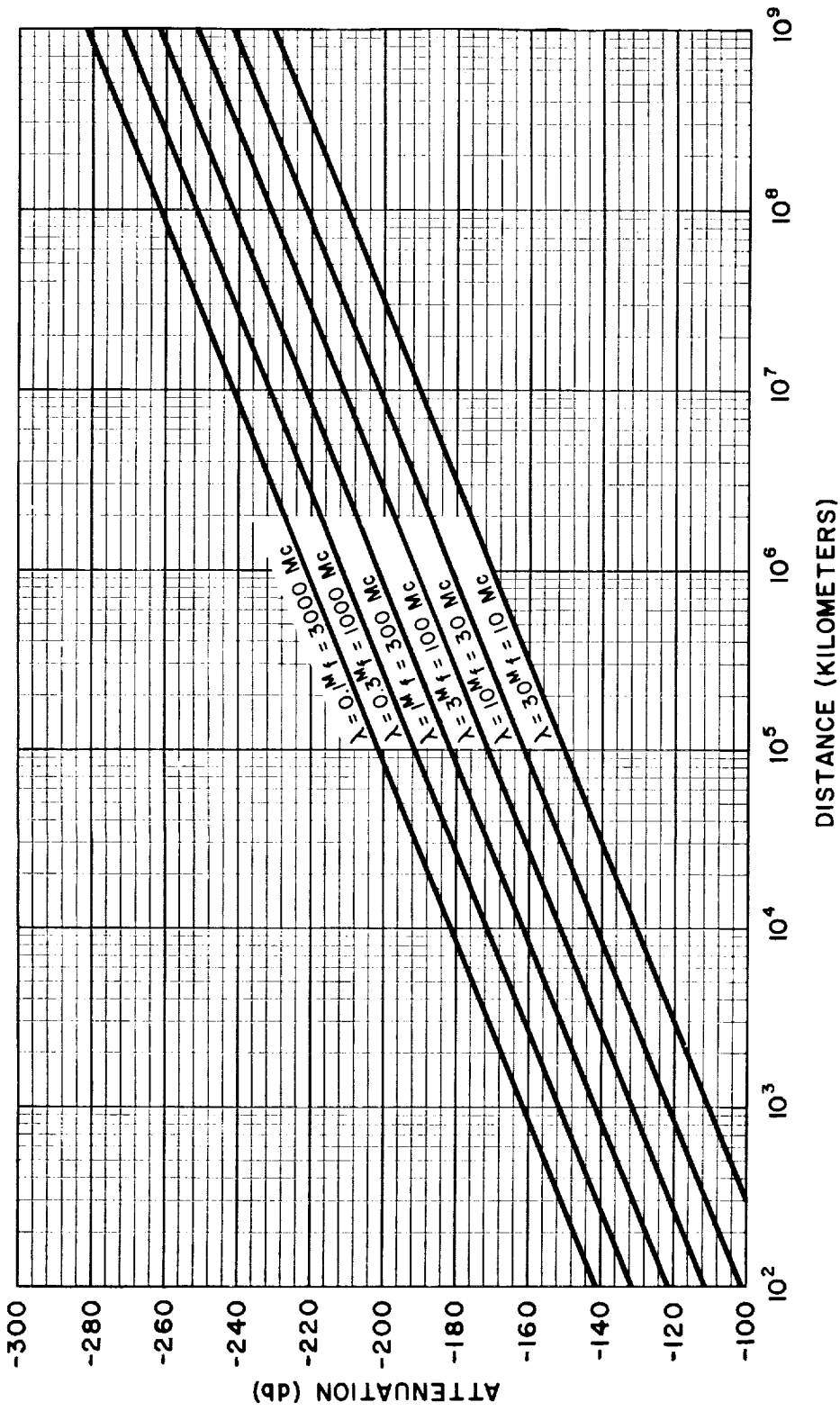

Figure 21A - Attenuation as a function of distance between isotropic radiators in free space (plotted in english units)



ATTENUATION vs DISTANCE (Between Isotropic Radiators in Free Space)

Figure 21B - Attenuation as a function of distance between isotropic radiators in free space (plotted in metric units)

magnetic fields; and from solar radiation. In general, these are all designated as radio stars, and appear as very small areas of intense radio activity. There are thousands of these radio stars; however, only about six of them taken individually have sufficient radiation intensity to degrade the received signal-to-noise ratio of present day telemetry systems. Their effects become more serious the narrower the beamwidth, or the higher the gain, of the receiving antenna.

For fairly wide-beam antennas (10 degrees or more) a far more serious source of noise exists at frequencies of several hundred megacycles and below; it is called the cosmic background noise or "sky noise." This source is the aggregate of millions of tiny sources so closely spaced that they no longer appear as discrete sources but appear continuous throughout the sky. Because this noise comes from the entire area viewed by the antenna, it cannot be described in terms of power density as would signals emanating from a discrete source. Its level is described in terms of effective sky temperature. For example, the noise level per cps of bandwidth at the output of an antenna's terminals equals the average brightness temperature in degrees Kelvin seen by that antenna multiplied by Boltzmann's constant $k = 1.38 \times 10^{-23}$ joules/°K. At 100 Mc, the sky temperature ranges from a minimum of about 400°K to a maximum of about 10,000°K, the higher temperatures corresponding to the region of the center of the galaxy. As the frequency rises the brightness temperature falls, the slope of frequency versus temperature being roughly 7 db per octave. Thus, the sky temperature at 64 Mc is about 2000°K minimum and 12,000°K maximum, while at 250 Mc it is about 100°K minimum and 700°K maximum. It is significant to note that in the region of 1000 Mc the sky temperature is a maximum of only 80°K and this is only for a small region enclosed by a few degrees. Most of the sky at this frequency is so close to absolute zero that the difference is difficult to measure.

Another important source of noise is the sun, which has a brightness temperature, when quiet, of about 10^6 °K in the frequency range from 50 to about 500 Mc. At other times, when the sun has been very active the temperature has been known to rise by a factor of about 10^3 or 30 db above this level.

Noise also originates within the receiving equipment, both as a result of shot effects in vacuum-tube amplifiers and as thermal noise associated with resistive losses in the circuit. Shot noise originates from the discreteness or granular nature of electrical charge, associated with electrons. Resistive losses arise not only in the usual circuit elements, but also may be associated with transit-time effects resulting from delays in electron flow response in vacuum tubes with respect to the signals applied to the grids.

Receiver noise is described in terms of the noise figure, which is defined as

$$F_N = \frac{kT_0B + N}{kT_0B} ,$$

where k is Boltzmann's constant, T_0 is room temperature in degrees Kelvin (290°K), B is the bandwidth in cps, and N is the noise generated within the receiver referred to the input terminals.

Of particular significance is the comparison of the relative levels of the various noise sources. These levels, referred to the receiver input terminals, have been evaluated for the 136- to 137-Mc Minitrack (tracking) receiving system. The antennas designated "fine" have a beamwidth of 8 by 80 degrees, while the coarse antennas are 100 x 100 degrees. The results (Figure 22) indicate that for broad-background cosmic noise the antenna beamwidth, as long as it is greater than about 10 degrees square, has little effect. However, for discrete sources such as radio stars and the sun, the received levels are directly proportional to the gain of the antenna.

In Figure 22, the receiver noise referred to the input terminals is shown as -134 dbm. (For purposes of this report dbm is defined as decibels with respect to one milliwatt.) From the noise figure definition

$$N = KT_0BF_n - KT_0B = KT_0B (F_N - 1).$$

With the available equipment, the noise figure is designated as 3 db which, in linear terms, is equal to 2; therefore

$$N = KT_0B.$$

Since $KT_0 = 4 \times 10^{-21}$ and B for the system is 10 kc = 10^4 ,

$$\begin{aligned} N &= 4 \times 10^{-17} \text{ watts,} \\ &= -134 \text{ dbm.} \end{aligned}$$

The minimum cosmic noise, on the other hand, is a little higher, being about -131 dbm when the antenna looks at the quietest portion of the sky. This noise rises about 5 db, depending upon the declination, when the antenna views the region occupied by the galactic center. Thus at this frequency, with a receiver noise figure of 3 db or less, the most serious limitation on signal-to-noise ratio is not the receiver but the background noise. In spite of their high intensity, the high level radio stars such as Cassiopeia, Cygnus, and Taurus do not appreciably increase the effective input noise because, although they are extremely intense, their radiating areas are so small that the noise received from the most intense of these sources reaches a maximum of only -134 dbm. On the other hand, this source of noise becomes increasingly important as antennas with higher gains are used. This is indicated by the reduced levels of radio star noise for the coarse antennas as compared to that from the fine antennas (Figure 22); the coarse antenna system has about 12 db less gain than the fine antennas. The sun is normally not a serious threat for a system of this kind; however, if it is within the beam pattern of the receiving antenna at the time of a flare or unusual activity it may well seriously degrade the received signal-to-noise ratio.

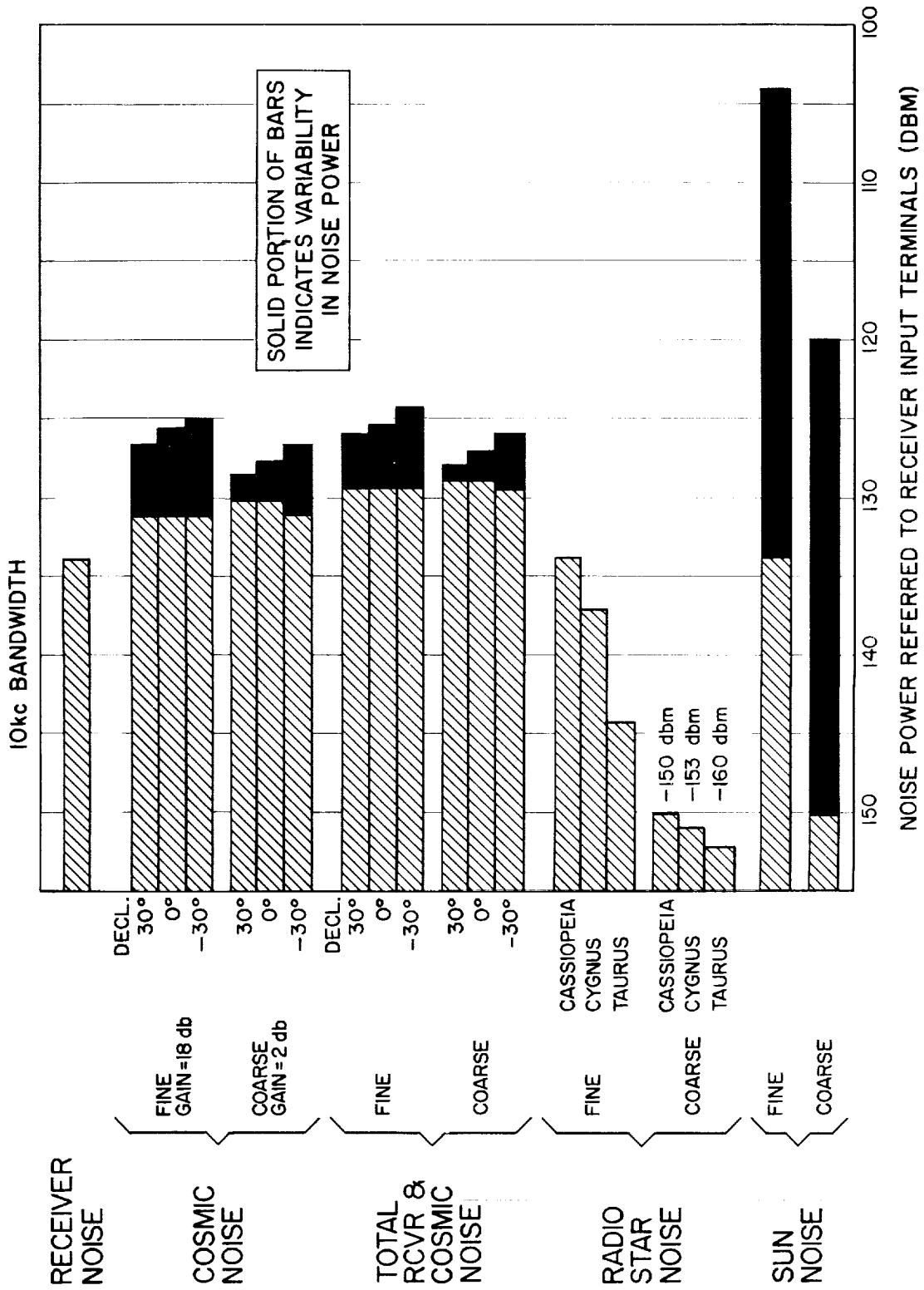

Figure 22 - Noise level in the 136-Mc Minitrack system

Man-made noise in the form of key-clicks, interfering signals within the frequency bandwidth of the receiver, or other sources of interference, can also be a serious limitation to the sensitivity of the receiving system. However, it is usually possible to locate the ground station far enough removed from such interference to reduce its effects to a negligible amount. This distance is in the order of tens of miles from cities and other concentrated areas of electrical machinery.

At present the major part of NASA's satellite tracking and telemetry is performed at a frequency of 108 Mc, but by the latter part of 1961 a shift will be completed to 136 Mc. It is likely that in the future the tendency will be to operate in the vicinity of 1000 Mc or above. The principal advantage of this higher frequency is the greatly reduced sky temperature and the reduced size of directive antennas for the space vehicles.

In view of the fact that the telemetry frequency associated with space activities will be 136-137 Mc for at least several years in the future, the remainder of this discussion will be confined to that frequency. Given the known levels of the various noise sources referred to the receiver input terminals, and assuming that the required signal-to-noise ratio for the bandwidth in question can be established, the required transmitter power can be found from the following expression:

$$P_t = \frac{P_r (4\pi R)^2}{G_r G_t \sigma \lambda^2}$$

where

P_t = transmitter power,

P_r = received power,

R = range,

G_r = gain of receiving antenna,

G_t = gain of transmitting antenna,

σ = effective signal loss due to aspect and polarization effects, and

λ = wavelength at the frequency used.

As an example of the power levels generally encountered in telemetry, it might be interesting to substitute some actual values into this equation. If the frequency is 136 Mc, the noise figure 3 db, the bandwidth 10 kc, and the gain of the receiving antenna 18 db, the total equivalent background noise level, from Figure 22, is a maximum of about -124 dbm. If a pre-detection signal-to-noise ratio of 15 db is desired, the received signal P_r must be -124 dbm - (-15 db), or -109 dbm, or about 10^{-14} watts. Let

R = 1609 kilometers (1000 miles),

$$R^2 = \begin{cases} (1.609 \times 10^6)^2 \text{ meters}^2 = 2.589 \times 10^{12} \text{ meters}^2 \\ (5.28 \times 10^6)^2 \text{ ft}^2 = 27.8 \times 10^{12} \text{ ft}^2, \end{cases}$$

G_r , at 18 db = 63,

G_t , at 0 db (isotropic radiation) = 1,

$$\begin{aligned}\sigma \text{ at } -6\text{db} &= 1/4, \\ \lambda^2 &= 50, \\ (4\pi)^2 &= 157.\end{aligned}$$

Then,

$$P_t = 55 \text{ milliwatts.}$$

Actually, it is usually necessary to provide for adequate reception at ranges of at least 4000 miles for general satellite work. Since the received level is reduced by a factor of 4 for each factor of 2 in range, the required radiated power at this range is 880 milliwatts.

Additional discussion of noise as a factor in space telemetry can be found in References 4 and 5.

AIRBORNE TELEMETRY SYSTEMS

The telemetry systems outlined below were used in the Vanguard, Explorer, and Pioneer projects. In general each satellite or space probe had a different objective which necessitated a custom-built telemeter, especially in the Vanguard Project. As a result of this, the descriptions of the telemetry which follow are typical of the various programs rather than specifications for standardized systems. The telemetry used in the Explorer and Pioneer programs followed, in some respects, the I.R.I.G. standards. All of the systems described used the IGY frequencies in the 108-Mc band and 960.05 Mc, and also 378 Mc. Additional information relating to airborne telemetry systems can be found in References 6 and 7.

Vanguard

The multiplexing and modulation method used in the Vanguard program can be denoted as PFM-AM (FM/PDM/AM), which means a time division multiplex with the individual pulses duration-modulated in time in accordance with the information in each channel, and the radio frequency carrier amplitude-modulated by the pulses. The FM group of letters means that the pulses, instead of having a constant value, are square-wave modulated at a frequency which corresponds to additional channels of information. This method evolved out of the need for an extremely small, light, and reliable telemetry package to be carried by the 9.1-kilogram (20-pound) Vanguard satellites. In addition to the ease with which the carrier is modulated in this system, it has the advantage of being adaptable for both high and low rates of information; yet it requires only a small amount of transmitter power for adequate signal strength at the ground stations. This and various other telemetry systems now in use differ from the established methods. The fact that they have arisen indicates the need for new standards and a thorough evaluation of the telemetry methods applicable to space research, in order to optimize the signal-

to-noise ratio at the output of the receiving equipment. These studies are currently being initiated. The following are the more pertinent technical data on the Vanguard system.

Size and Weight

The transmitter, encoder and batteries occupy a volume of 8,360 cubic centimeters (510 cubic inches) and weighs approximately 3.0 kilograms (6.5 pounds). The complete satellite unit including all batteries is 14 centimeters (5.5 inches) in diameter and 19 centimeters (7.5 inches) high and weighs 3.5 kilograms (7.8 pounds). The basic 48-channel telemetry encoder weighs approximately 91 grams (3.2 ounces) and requires 12 milliwatts operating power (4.4 ma at 2.7 volts). The low operating power permits continuous operation for a period in excess of three weeks with batteries weighing 79 grams (2.8 ounces).

Input Characteristics

The input characteristics, of the system will, in general, be determined by the experiment. This equipment accepts inputs which consist of variable voltages, variable currents, and variable input resistances.

Data Storage and Transmission

Two memory units were used in this system. Information was stored in magnetic cores in which the flux level is a function of the peak value of current flow in the input winding. One device stored information while the other was continuously reading out previously stored information. The roles of these two were reversed when the satellite passed from darkness into light, or upon interrogation. A second system stored up to 3 decimal digits of information on cumulative counts of impact with micrometeorites. The following types of data were transmitted: micrometerite impacts, radiation measurements, space environment, and cloud cover.

Transmitter Characteristics

The transmitter operates on 108 Mc, and radiates 100 mw of power with 100 percent modulation. (To date, transmitters capable of radiating 2 watts have been built; in general, however, the transmitter usually is designed and fabricated for the specific experiment.) The modulation waveform is a series of "tone bursts" and "blanks." These bursts lie in the frequency range from 5 to 15 kc. The blanks are time intervals between 5 and 30 msec.

Mallory mercury cells, which provide 0.11 watt-hours of energy per gram (3.2 watt-hours per ounce) of battery weight, are the primary power source for the transmitter. The expected life of these batteries in this application is between 3 and 4 weeks.

The Vanguard antenna consisted of four metal rods, providing both linear and circular polarization. Other types of antennas have been used, however.

Number and Frequency Response of Channels

In the experiment, 48 commutated channels were used; however, this may vary with the experiment. The 48 channels were sampled 3 to 4 times per second. The scanning rate changed as the input signals changed. The frequency response for any one channel depends on the sampling rate; however, in this system both the slope and magnitude of the data item for the tone burst channels were telemetered as they existed at the time of sampling. A 96-channel system is possible by the addition of another section in the encoder.

Some Telemeter Environmental Requirements

In general, the thermal limitations were imposed on the payload by the batteries. The telemeter circuitry limited the temperature excursions from 0° to 60°C. Test procedures require that the telemeter withstand 25-g (rms) white noise vibration from approximately 25 to 2500 cps, and 100-g acceleration in the centrifuge. It should be pointed out that the telemeter was thermally isolated from the shell or outside skin where the temperature excursions were much greater than the internal temperature.

Explorers I and III

Size and Weight

The total electronic payload was 5.36 kilograms (11.8 pounds). Including the structure and antenna, the electronic payload weighed 8.26 kilograms (18.2 pounds). The volume occupied by the telemetry was approximately 1970 cubic centimeters (120 cubic inches).

Input Characteristics

A resistance-controlled oscillator was used whenever the basic variation produced by a sensor was that of resistance. The oscillator then converted change of resistance into a frequency variation which could be modulated on a radio frequency carrier. In a similar fashion a current-controlled oscillator was used when the sensor output would most readily be developed as a change in current; this was then converted by the subcarrier oscillator to a frequency variation for modulation purposes.

Data Storage and Transmission

Explorer I used continuous data transmission while Explorer III used continuous data transmission plus playback upon command. No capability existed in Explorer I for data storage. Explorer III contained a magnetic tape recorder. The types of data transmitted by this system were: Skin and internal temperatures, cosmic ray measurements, and micrometeorite impact data.

Transmitter Characteristics

The low-power (10-mw) transmitter operates on a frequency of 108.00 Mc and is phase modulated. It is powered by six RM-42 mercury cells with a life-expectancy, in this application, of 2 months. A dipole antenna is employed, providing linear polarization of the radiated signal.

The high-power (60-mw) transmitter operates on 108.03 Mc and is amplitude modulated. Its power source of 24 RM-42 mercury cells has a life expectancy, in this application, of 2 weeks. A turnstile antenna is used for this transmitter, providing circular polarization of the radiated signal.

Subcarrier Oscillators

Four subcarrier oscillators, operating within the Standard I.R.I.G. channels, were used in Explorer I for both the low- and high-powered transmitters. In Explorer III the four subcarrier oscillators were used with the low-power transmitter while the high-power transmitter, upon interrogation, transmitted the cosmic ray count data which were stored on magnetic tape.

Pioneer II

The following are the more pertinent technical data on the Pioneer II system.

Size and Weight

The electronic payload weighed 10.2 kilograms (22.5 pounds). This included the two transmitters, command receiver, antenna, batteries, and other associated equipment. The telemetry doppler transmitter was 10.2 x 6.4 x 3.2 centimeters (4 x 2.5 x 1.25 inches) in size and weighed 400 grams (14 ounces). The weight of the doppler and command receiver was 2.6 kilograms (5.7 pounds) including batteries, and the total volume was 1480 cubic centimeters (90 cubic inches). Subcarrier oscillators, the scientific instrumentation, batteries, and converters were attached to the payload structure in a circular ring; the outside diameter was 74 centimeters (29 inches) and the inside diameter was approximately 58 centimeters (23 inches).

Input Characteristics

The subcarrier oscillators were designed to operate with a variable resistance input. They were basically Hartley oscillators, each employing a variable resistor in shunt with one of the frequency determining capacitors to produce the desired frequency modulation.

Data Storage and Transmission

The 300-mw transmitter was transmitting telemetry data continuously except when, on command from the ground stations, the transmitter functioned as a return link of a two-way doppler system. A second transmitter, with a power of 100 mw, was used to supply telemetry during Doppler interruption of the 300-mw transmitter and, at other times, redundant telemetry. The system was designed to yield a signal-to-noise ratio of 10 db over a 10-cps passband. No data storage capabilities were provided. The types of data transmitted were: Ion chamber information, internal temperature and magnetometer data, the micrometeorite total count rate, and the spot-scan television data.

Transmitter Characteristics

The low-power (100-mw) transmitter operated on a frequency of 108.09 Mc and was phase modulated. The primary power source consisting of mercury cells provided a life expectancy, in this case, of 100 hours.

The high-power (300-mw) transmitter operated on 108.06 Mc and was also phase modulated. Mercury cell power provided a life expectancy, in this case, of 10 to 15 days.

The low- and high-power transmitters shared a common dipole antenna consisting of two 12-inch whips, thus providing linear polarization for both radiated signals.

Subcarrier Oscillators

Six subcarrier oscillators were used, corresponding to the first six I.R.I.G. standard channels.

Pioneer IV

The following are the more pertinent technical data on the Pioneer IV system.

The total weight for payload components was 6.3 kilograms (13.8 pounds). The input characteristics of the three subcarrier oscillators consisted of voltage controls. One-way doppler data were transmitted, as well as FM/PM telemetry including a cosmic ray logarithmic scaler, radiation, and photoelectric measurements. The 250-mw phase-modulated transmitter operated on 960 Mc through a conical dipole antenna. Mercury cell power provided, in this instance, a life expectancy of 82 hours. The frequency responses of the three channels were 2, 4, and 8 cps.

Additional discussion on telemetry encoders can be found in Chapter 4. A detailed description of the telemetry system used for Satellite 1959 IOTA (Explorer VII) can be found in Reference 8.

RECEIVING FACILITIES

Minitrack System

In addition to their tracking function, the Minitrack stations (Chaper 7) have a separate capability for receiving and recording telemetered information from satellites as well as for transmitting certain specific command signals. The latter process is frequently called interrogation, as it is often used to control the read-out of information stored in the satellite.

A typical station using the 108-Mc frequency is equipped with the following major items of electronic equipment:

- 2 108-Mc Minitrack receivers
- 1 R 220 receiver tuning 20 to 220 Mcs
- 2 Linear detectors
- 1 Converter, 108 Mc to 16 Mc
- 1 Ampex FR 107 7-channel tape recorder for AM, FM, and POM modulation
- 2 R 390 A/receivers tuning from 0.5 to 32-Mc, Hewlitt Packard (HP)
- 1 524B electronic counter
- 1 Interstate tracking filter
- 1 Model 535 Tektronix oscilloscope
- 1 Tunable subcarrier discriminator
- 1 HP 608D signal generator
- 2 Collins 242 G interrogation transmitters, tuning from 108 to 152 Mc
- 1 Rotatable (one plane only) 108-Mc antenna array
- 1 108-Mc Yagi antenna, directable
- 1 20-Mc dipole antenna mounted on a ground screen and oriented to look directly upward

There is also a set of spare parts along with miscellaneous test and maintenance equipment. Some stations have additional equipment for specific applications.

The rotatable Minitrack antenna has a gain of about 12 db, a beamwidth in the north-south direction of 80 degrees and in the east-west direction of 8 degrees (between the 3-db points). Its median pointing direction is directly upward, but it may be rotated 80 degrees to the east or west, thereby covering an angle of 160 degrees plus the beamwidth of the antenna, or a total of 168 degrees. This antenna is manually aimed by using the signal level information obtained from the telemetry system. To aid the operator in this operation, a visual graphical recorder indicating the signal level is part of the equipment at each station. The recorded signal level aids the operator in differentiating between signal level variations due to satellite roll and those due to less than optimum pointing of the receiving antenna.

The Minitrack receiver was originally designed for 108 Mc only; however it has since been modified, by the addition of crystals and a crystal switching unit, to accommodate additional channels at ± 30 kc, ± 60 kc, and ± 90 kc from this center frequency. This unit has three pre-detection (i.f.) bandwidths (3, 6, and 30 kc), any one of which can be switched into the circuitry. The receiver noise figure is approximately 3 db. There is a conventional amplitude detector, providing output levels compatible with the desired 1-volt input level to the tape recorder. In addition, the second i.f. signals at a frequency of 470 kc are translated to about 27 kc by the linear detector and brought out directly for recording at this frequency without detection. The reason for recording the pre-detected signal, a process called linear detection, is that the bandwidth required to pass all the subcarriers and side bands present in the received signals is so large that the accompanying noise may be large compared to the signal. Conventional detection would thus result in a degradation of the signal-to-noise ratio due to the detection process. On the other hand, the recorded i.f. information can be played back through frequency selective networks which markedly improve the signal-to-noise ratio, so that the detection process will not degrade the information.

The Ampex FR 100 tape recorder is a 1.3-centimeter (0.5-inch) tape recorder having seven recording channels. Six of these channels are equipped for direct recording, and one is equipped with a pulse-width plug-in unit for recording digital time pulses from the time standard equipment in the Minitrack tracking system. FM plug-in units are available for recording dc voltages and low frequency signals. This recorder operates at speeds of 152, 76, 38, 19, 9.5, and 4.75 centimeters per second (60, 30, 15, 7-1/2, 3-3/4, and 1-7/8 inches per second), which correspond to maximum frequency recording capabilities of 100, 50, 25, 12-1/2, 6-1/4, and 3-1/8 kc, respectively. It is expected that, as required by the increased bandwidth of future experiments, tape recorders with greater capabilities will be installed.

The Collins 242G VHF transmitter is tunable over the frequency range from 108 to 152 Mc. An output power of 200 watts is available and in practice, with the command receivers discussed in Chapter 4, it has been possible to provide signals to the satellites at distances up to 33,800 kilometers (21,000 miles). These units are supplied with special modulation coders which modulate the transmitted signal so that the decoding instrumentation contained by the satellite will respond.

The interrogation transmitters are sometimes used to command satellites to transmit data recorded during the previous orbit. Other experiments have required a command from the ground to increase the transmitter power while within range of a particular ground station. In the future the interrogation systems will play an increasingly important role as the complexity and sophistication of satellite experimentation increases.

New Developments in the Minitrack System

The first Minitrack telemetry receiver was developed to meet requirements which have since been modified markedly by the increased scope and complexity of telemetry and by the need for more and faster data transmission. As has been mentioned, the frequency allocation at 108 Mc (used during the IGY) will be terminated in the latter part of 1961, and a new allocation in a 1-Mc band beginning at 136 Mc will be available. For this reason a new receiving system has been designed and the prototype constructed. It is anticipated that after evaluation and acceptance of this system, each of the 14 Minitrack stations will be provided with two complete systems.

A principal feature of this receiver is the manner in which it is tuned. Thirty quartz crystals are used to provide 1,000 discrete crystal-controlled tuning points in the 1-Mc band. This is accomplished by placing a crystal switching unit containing ten crystals into each of the three local oscillators of this triple-conversion receiver. The first local oscillator is tunable over a 1-Mc band in ten 100-kc steps; the second is tunable over a 100-kc band in ten 10-kc steps; and the third is tunable over a 10-kc band in ten 1-kc steps. Thus, the three combinations of ten provide 1,000 discrete tuning points.

The second principal feature is the variable pre-detection bandwidth, which is selectable in five steps: 10 kc, 30 kc, 100 kc, 300 kc, and 1 Mc. Signals at each of these bandwidths can be translated by a fourth mixer stage to a converted frequency which may be recorded directly on magnetic tape. The converted frequency may also be fed into a tracking filter to take advantage of phase-lock techniques, which provide coherent detection and extremely narrow-band operation with the accompanying advantage of noise reduction. These receivers will also be supplied with low noise preamplifiers employing the relatively new 7077 ceramic planar triode. At 136 Mc the noise figure obtainable from these tubes as grounded-grid amplifiers is 3 db. Both AM detectors and FM discriminators will be supplied for each of the bandwidths included. Phase demodulation will be performed by the phase locked tracking filters.

This system will also have the capability of supplying Doppler information in digital form. The input signals are translated four times and fed into the tracking filter. This unit excludes a great deal of the noise by passing the signal through a narrow band filter, and supplies a virtually noise free output signal equal in frequency to its input signal. The frequency of this signal, if recorded directly, would contain the frequency instabilities of all the local oscillators; however, by a process called synthesizing which employs the same local oscillators used in the downward translation in an upward translation, the signal is translated back to the frequency of the input signal. By this process the local oscillator's effects upon the frequency are completely removed. The synthesized signal at 136 Mc is fed to the Hewlett-Packard counter and printer which displays the frequencies as a list of tabulated numbers occurring every other second. The basic accuracy of the system depends upon the counter which, because its electronics operate

from the external 100-kc standard supplied by the Minitrack time standard unit, is accurate to within a few parts in 10^9 , thus making it possible to measure a frequency near 136 Mc to within 1 cps.

Automatic Aiming Antenna Under Development

To avoid operator errors in aiming the telemetry antenna properly, an antenna system which acquires and locks onto signals from satellites has been conceived and is being designed for use with the 136-Mc system. The pedestal for this unit is designated an X-Y mount, which is similar to an azimuth-elevation mount turned on its side (Figure 23). This type of mount was chosen in lieu of the azimuth-elevation type because the latter type supplies no correction information as satellites pass directly overhead. In the X-Y mount the dead spot is on the horizon. The antenna guidance consists of a pair of radio interferometers with baselines corresponding to the rotational axis of the mount. The X-Y mount supports a ground screen upon which are mounted four 136-Mc yagis placed 1-1/2 wavelengths apart. Error signals derived from the phase differences of the signals impinging upon the antennas drive a pair of servo systems in such a direction as to minimize these phase differences. Thus, after acquisition, the antenna will lock onto the received signal and follow the source across the sky. Occasional signal drop-outs should not be of any consequence because of the long time-constant associated with the drive system, and because the time necessary for even low satellites to escape from the approximately 20-30 degree beamwidth of the antenna is a minimum of about ten seconds. For telemetry purposes the outputs of all the four antennas are added and fed to the input of the receiver. In addition, there is a separate full set of yagis to provide for polarization diversity, or the orthogonal elements can be connected in quadrature to permit reception of circularly polarized signals. The prototype of this antenna system is now under construction and will be tested at the Blossom Point Minitrack Station with 108-Mc satellite signals.

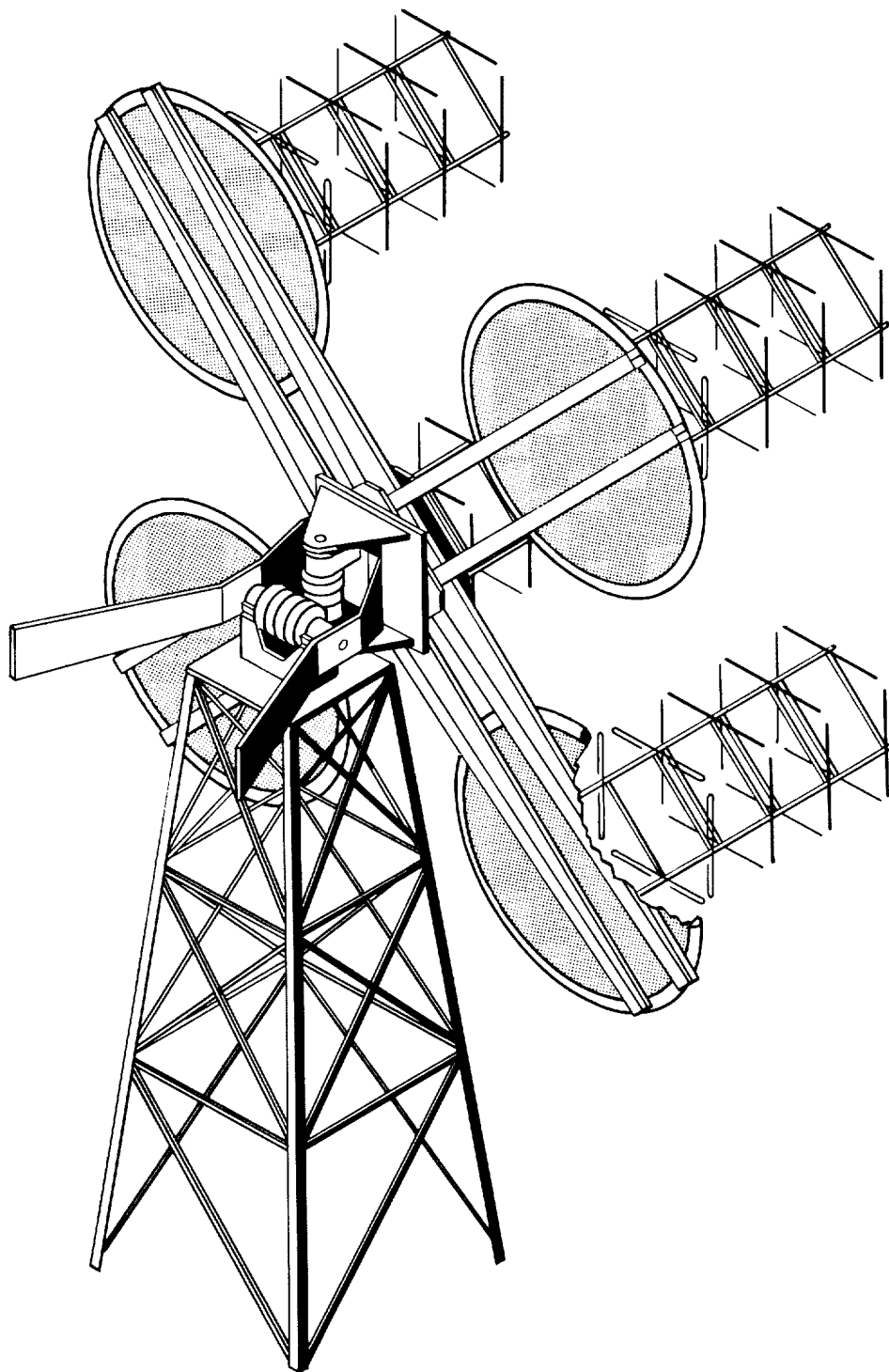

Figure 23 - Automatic aiming antenna

REFERENCES

(Chapter 8)

1. U. S. Department of the Army, White Sands Proving Grounds, "Telemetry Standards for Guided Missiles," Inter-Range Instrumentation Group Steering Committee Document No. 103-56, October 1956
2. Matthews, Whitney, Rochelle, R. W., et al., "Cyclops Cores Simplify Earth Satellite Circuits," *Electronics*, 31(9):56-63, February 28, 1958
3. Matthews, Whitney, "Receiving U. S. Satellite Signals," *Electronics World* (formerly *Radio and TV News*) 59(3):35-38, 154-158, March 1958
4. Smith, Alex G., "Extraterrestrial Noise as a Factor in Space Communications," *Institute of Electrical Engineers Proceedings* 48(4):593-599, April 1960
5. Dimond, Robert H., "Interplanetary Telemetry," *Proc. IRE* 48(4):679-586, April 1960
6. Williams, W. E. Jr., "Space Telemetry Systems," *Proc. IRE* 48(4):685-690
7. Rochelle, R. W., "Signal-to-Noise Considerations for a Space Telemetry System," *Proc. IRE* 48(4):691-693, April 1960
8. Cherrick, Irwin L., "Telemetry Code and Calibration for Satellite 1959 Iota (Explorer VII)," *NASA Technical Note D-484*, May 1960

CHAPTER 9

DATA ACQUISITION, PROCESSING, AND ANALYSIS

As has been mentioned earlier, the experimenter obviously cannot accompany his equipment to operate on and record the data. He is dependent, therefore, on the radio link to telemeter information to ground recording stations. Despite whatever success is achieved in designing experiments and equipment, in packaging and testing, in launching and tracking, the ultimate measure of accomplishment for the experimenter lies in the satisfactory acquisition, processing and analysis of the information being sent by the space package. An adequate data acquisition, processing and analysis plan should be prepared at an early stage of the preparation for a satellite experiment.

ACQUISITION

Both the Minitrack and the Deep Space Network have facilities for recording frequency-translated, undermodulated, and demodulated telemetry signals on magnetic tape. At the time when the data is recorded at the ground station, standard time and frequency signals are added on separate channels of the tape. In some cases the telemetry signals are recorded on a different frequency or frequencies than that of the tracking signals. In cases where Minitrack cannot demodulate in the field, the procedures described in the previous chapter under receivers will be utilized. The taped data are transmitted by mail to a central data processing station. For earth satellite programs this station will be under the cognizance of the Goddard Space Flight Center. For deep space probe studies this station will be directed by the Jet Propulsion Laboratory.

The telemetry coverage will, in general, be provided by the stations in the network previously described. On special occasions it may be desirable, for more complete geographic coverage or in order to provide continuous-time data recovery, to establish special telemetry receivers at points remotely located from existing stations. Provision for such stations must be made early in the planning of a given satellite experiment, since international agreements, funding, and details of operation must be arranged well in advance of the launching date.

Careful planning of the data acquisition program will contribute substantially to the efficiency of the data processing and analysis stage.

For certain experiments, continuous data acquisition is unnecessary, and data sampling on a predetermined plan may provide adequate coverage. It also may be feasible to have information storage devices within the satellite with provisions for command read-out from control points in the ground network. In addition, since some stations will be equipped with visual recorders of the direct writing type, the operators at those stations can obtain an immediate impression of the quality of the telemetry reception. It is possible to make use of these charts for initial scanning to provide preliminary on-the-spot analyses, although station personnel have not been specially trained for this function.

PROCESSING

The data processing procedures to be associated with a given satellite experiment should be planned as part of the experiment. Equipment for the processing of data telemetered by the FM/PDM/AM system described earlier is available at the Goddard Space Flight Center. With this equipment it will be possible to separate out the various frequency and pulse-width bursts into either analog or digital printed records. These records can then be made available to the experimenter, together with appropriate calibration data so that he can proceed with the analysis.

The processing of the data is considered to be semi-automatic at this point, and the quality of the processed data very much depends on the received signal-to-noise ratio. The higher that ratio the more automatic procedures can be introduced to transfer data directly from tape to a print-out or chart record. Continued development of processing techniques, with the objective of improving and increasing automatic procedures, is currently underway.

COMPUTING FACILITIES

To date, data from satellites have undergone very little in the way of automatic processing requiring computer facilities. It will be possible in the near future to utilize the automatic scaling factors of the Automatic Recording and Reduction Facility (ARRF) Computer which is being installed at the Goddard Space Flight Center. This implies that the data must have a high signal-to-noise ratio. Eventually, new telemetering systems must meet this requirement and processing by general purpose digital computers will be possible - this is definitely a requirement if large volumes of data are to be handled.

ANALYSIS

In the present state of the art, data are received in a form requiring that considerable skill and judgment be exercised by the person who processes it. It is necessary that a high degree of rapport exist between the experimenter and the processor of this data. At present, the data are processed and then sent to the experimenter for analysis.

This analysis may suggest a new requirement for processing - perhaps a method which enhances a particular type of data. In that case the data are reprocessed and reevaluated.

It is to be hoped that future data processing equipment and techniques will allow specifications for data transmission, recording and processing which will make possible a single quick, automatic procedure.

CHAPTER 10

COMMUNICATIONS

The various NASA Minitrack tracking and telemetry stations throughout the world are integrated into a coordinated network by the NASA Space Communications Network (Figure 24). The teletypewriter circuits from the various stations terminate in the NASA Space Operations Control Center (NASA SPACECONN) at Washington, D. C. In addition to the NASA tracking and telemetry stations, the Space Communications Network has links with the NASA Computing Center, the U. S. missile launching ranges, and other agencies and organizations engaged in cooperative efforts with the NASA. SPACECONN also has outlets to the commercial and U. S. military communications networks, so that message-type communications are possible with nearly any location in the world.

The network diagram (Figure 24) shows the NASA Space Communications Network in schematic form.

As can be seen from the diagram, the network philosophy is that each terminal is a spoke emanating from SPACECONN with no peripheral links between stations. Since SPACECONN is manned continuously 24 hours per day, 7 days per week, traffic between stations can best be handled by relay through SPACECONN. This method provides positive network control at a central location at all times in the most efficient and economical fashion.

The NASA Space Communications Network is essentially a closed net in that its primary utilization is to handle tracking and telemetry data, operational and administrative traffic, and technical information generated within NASA and cooperating agencies or activities. However, activities not formally associated with the NASA but situated near a NASA station may pass data or information to SPACECONN through these communications links when such traffic is of concern to the NASA effort in the exploration of space. Since the network is closed or private, traffic originated outside the net and destined for one of the net terminations must be addressed to SPACECONN for relay to the proper stations.

A somewhat similar system has been established for the NASA-JPL Deep Space Network to provide communications between stations. Network control is located on the grounds of the Jet Propulsion Laboratory in Pasadena, California. A flow diagram of the JPL communications network is shown in Figure 25.

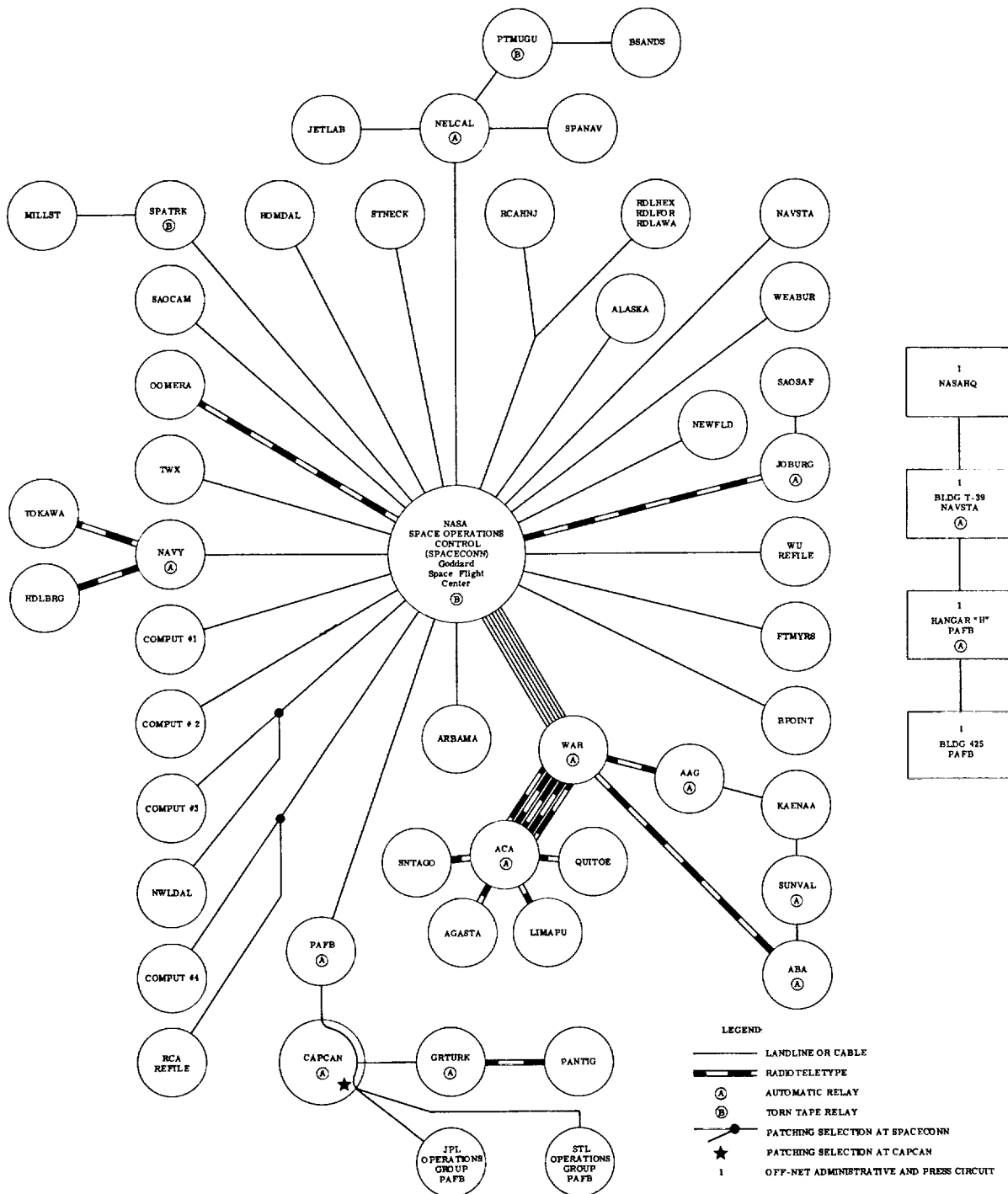

Figure 24 - Spaceconn communication network and adjuncts

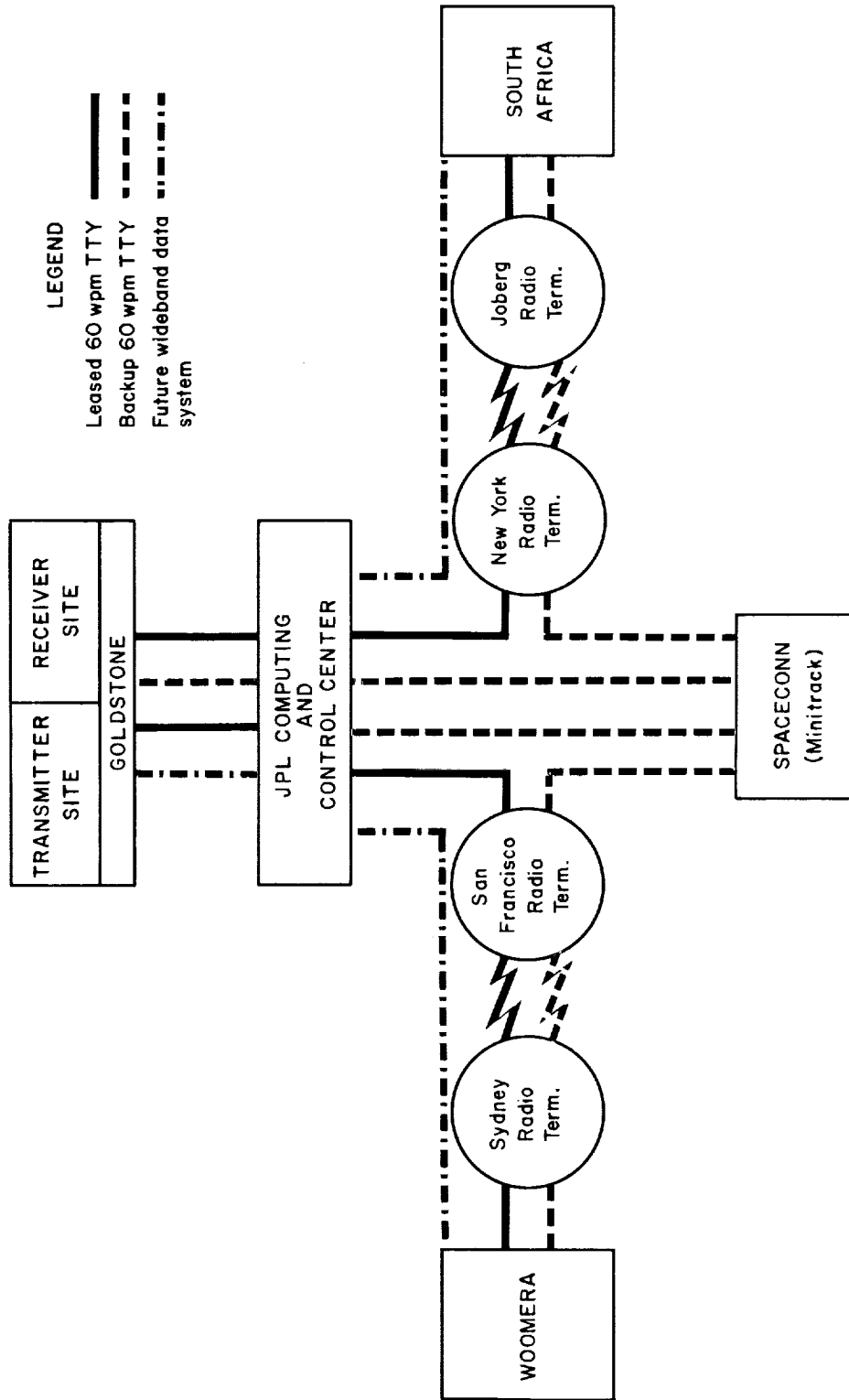

Figure 25 - Jet Propulsion Laboratory communications network

CHAPTER 11

PROJECT MANAGEMENT

The overall effort required to launch a satellite calls for hundreds of man-years of scientific and engineering activity. It is essential that the experimental scientist, probing for new knowledge about the universe, acquire an appreciation for the magnitude and expense of this effort. Unless this awareness exists, the satellite experiment itself will not appear in its proper perspective. So many scientists, engineers, and technicians are involved in the overall effort that any one individual contributes but a relatively small part to the overall success of the experiment. Finally, the satellite experiment will appear in its true perspective when it is recognized that the satellite itself involves only a portion of the total work and, more significantly, that at launch it is only another piece of hardware until it is injected into orbit.

The basic element of success in launching satellites is teamwork. A successful team will have: (1) strong technical leadership, (2) competent personnel for all areas of work, (3) clearly defined assignment of responsibility and delegation of authority within the team, (4) mutual respect and cooperation among the members of the team, (5) a clear and detailed statement of the objectives or goals to be achieved, and (6) adequate facilities available as appropriate for the mission.

PLANNING THE EXPERIMENT

Careful planning of the experiment can be accomplished only after all of the constraints and boundary conditions are established. The experimenter then must devise the most useful scientific experiment within the given set of initial conditions and restraints, and state the objectives clearly and concisely.

In many cases it will be found that the first experiment should be planned for wide dynamic range rather than high accuracy. Initial experiments should be simple; the design should be conservative. Optimization should be performed only when there is sufficient justification and then only when there has been time enough for a thorough evaluation of initial studies. Only when the preliminary experiments have proven successful should sophistication be added.

The complex nature of a satellite experiment requires a plan for an entire program, from the control of the engineering design of the satellite experiment to the publication of results. The following, based on experience gained in developing and launching

instrumented satellites, is a partial list of reminders for use in planning a program:

1. Acquire an appreciation for the magnitude and expense of the overall effort.
2. Plan to become a working member of a team.
3. Recognize all of the constraints and boundary conditions in planning the experiment; state the objectives clearly and concisely.
4. Hold preliminary and continuous discussions with the agency having cognizance of the satellite payload.
5. Schedule preliminary tests in high-altitude rockets, as necessary.
6. Avoid imposing additional constraints on the vehicle system which will be used to launch the satellite.
7. Adopt a thorough, complete, and realistic program of environmental testing; use time-tested techniques and components in the design of the experimental hardware.
8. Meet scheduled commitments.
9. Minimize, clearly define, and be prepared to support and tolerate the requirements for prelaunch field operations.
10. Prepare early for handling the large volumes of data which are typical of satellite experiments in order to expedite the reduction, analysis, and publication of the information.

CONSTRAINTS ON THE LAUNCHING SYSTEM

The cost of developing a vehicle system capable of launching a satellite substantially exceeds the cost of developing an instrumented payload. The cost of modifying the vehicle system to accommodate a particular experiment will, of course, depend upon the extent of the modification; however, the alteration will probably be expensive, the reliability may be impaired, and the probability of success may be reduced. Therefore, it behooves the experimenter to minimize the modifications on the system.

Constraints exist in certain areas which may limit the experimenter. It will be necessary for him to obtain specific tolerances with respect to the applicable constraints. The following is a limited listing of areas in which such constraints may exist:

1. Requirement for a circular orbit.
2. In an elliptical orbit, a requirement for specified altitudes of perigee and apogee.
3. Controlled on-axis spin rate (including zero spin rate) either before, during, or after injection into orbit.
4. Specified minimum precession angle about the spin axis.
5. Controlled spatial attitude.
6. Restrictions as to maximum linear acceleration during launch.

7. Specified date and time for launch.
8. Requirement for protruding members which may affect the launch operation.
9. Requirement for a particular orbital inclination to the earth's equator.
10. Payload weight for a specified trajectory.

It is recognized that additional constraints may exist which are not mentioned here. When constraints are essential for the performance of the experiments, it may be necessary to reach compromises with the requirements. When this is not the case, simplicity demands that the constraints not be imposed. For each launching vehicle system a specific set of restraints or tolerances apply. These constraints and the compromises reached will determine which experiments can be flown in a particular vehicle.

PRELIMINARY DISCUSSIONS

Preliminary discussions should be held with the agency expected to have cognizance of the satellite payload, to effect the interchange of information on the many areas which must be agreed on by both groups. The results of such a discussion will affect both the scientific and the engineering design of the experiments. Typical of these areas of discussion are:

- Weight
- Size
- Shape
- Power consumption
- Life expectancy
- Type of primary power
- Separate or common power supplies
- Total quantity of information desired
- Coding of the information
- Information rates
- Information storage
- Calibration equipment, techniques, and procedures
- Types and location of sensors
- Accuracy
- Dynamic range
- Payload environment expected
- Environmental test specifications
- Vehicle system constraints
- Provisions for turn-on
- Scheduling
- Ground instrumentation
- Data handling and processing

Signal-to-noise ratios expected
Integration of experiments

HIGH-ALTITUDE ROCKET TESTS

A rocket-borne system is at least one order of magnitude less complicated and less expensive than a satellite system. On the other hand, a rocket-borne system is at least one order of magnitude more complicated and more expensive than a laboratory experiment. High-altitude rocket tests are valuable because they confront the experimenter with many of the problems he will encounter in satellite work. In addition, such tests provide an opportunity to determine the dynamic range over which the equipment will have to operate. This may eliminate preliminary survey types of experimenting in costly satellite vehicles. Typical problem areas common to both rockets and satellites are:

1. Hardware design for a rugged environment.
2. Simulated environmental testing before flight.
3. High equipment reliability under adverse conditions.
4. Training of personnel for design, fabrication, inspection, testing, field operation, data gathering, etc.
5. Coordination with other agencies, such as the missile firing crew, range safety, range instrumentation, flight telemetry, etc.
6. Preparation of development schedules and the experience of working to meet a schedule.
7. Gathering, reducing, analyzing the flight data and preparing the final flight report.

There is no substitute for a good rocket test, and the planning of satellite experiments should include preliminary test flights in rockets whenever such flights could be shown to be beneficial; i. e., whenever they would increase the chances for success of a future satellite experiment.

ASSEMBLY AND CHECKOUT

Under the Scout program, responsibility for the vehicle, its assembly and checkout, will rest with the NASA and/or its collaborators. The experimenting groups will be responsible for fabricating prototypes of their payloads under pre-established agreements as applicable. The experimenters will be responsible also for monitoring both prototypes and final payload packages at the environmental testing and checkout

facilities. It will be the responsibility of the experimenters to make certain that the payload is acceptable for launching, and to be adequately represented during the actual launch.

When the instrumentation for the experiments has been designed and fabricated, it must be incorporated into a suitable package complete with telemetry and tracking equipment. Close cooperation between the experimenters and the mechanical and electrical design groups will insure an integrated and compatible final package.

The completed prototype payload comprising the various instrumentation packages and other subsystems will be checked for performance under an environmental testing program designed for the payload. This testing will be carried out at an appropriate facility with the assistance of delegated representatives from the experimenting agencies, who will monitor the results of the tests to insure proper performance of all instrumentation. In the event of a payload failure during the environmental tests, the prototype payload must be modified until the system performs properly.

The final flight payload and the necessary backup payloads will be given flight acceptance tests. These tests include dynamic balance, acceleration with spin, temperature calibration thermal vacuum, rf radiation tests, and functional tests. It is desired to have acceptable payloads in the field several weeks prior to the launching date.

In the field, the payload will again be checked for satisfactory operation. It is also necessary that the backup payloads be checked during this time. The instrumentation package should operate and perform without any adjustments. No repairs should be attempted in the field since facilities and equipment are limited. Replacement or adjustment of a component or subsystem should be made only as a last resort to meet a firing date. The backup payloads should be used if a malfunction is found in the final payload.

During checkout in the field, rf radiation measurements are made. The telemetry, tracking, and associated equipment are checked in conjunction with the instrumentation in the payload to insure complete operability and compatibility with the ground station.

SCHEDULED COMMITMENTS

The mechanism for coordinating the overall satellite experiment activity is the development and firing schedule. This schedule is a document which essentially informs everyone associated with the program when certain events will occur and when related tasks must be completed. Therefore, one of the first requirements of a participating satellite experimenter is to prepare a schedule of his activities for integration into the master fabrication and checkout schedule of the launching vehicle system. This schedule should be prepared with extreme care and some conservatism. Extra time should be included as a safety margin when there are unknown factors in the development program.

The schedule of operations is a binding document to an experienced vehicle agency, and the best way to establish good working relationships and confidence among participating agencies is to demonstrate a capability for preparing and complying with realistic schedules.

Preparatory and operational activities associated with the large vehicle systems are generally so complex that it is impossible to operate effectively without the discipline of a rigid time schedule. The tolerances in the schedule become tighter as the firing date approaches. Several months ahead of the firing date, the tolerance may be a few weeks; several weeks ahead, it may be a few days; several days ahead, a few hours; and several hours ahead, only a few minutes or seconds. A typical development schedule for a satellite instrument package is summarized in Table 11. From the schedule, it may be seen that the initial study, experimentation, prototype design, and testing take about twelve months. The fabrication of flight hardware, testing, calibration, assembly into the payload, and final checkout take about five months and one month is reserved for the prelaunch field operation. It should be emphasized that although Table 11 is shown for a twenty-four month developmental period, in many cases substantially more or less time will be required. It is a joint responsibility of the project manager and the experimenter to agree on a time scale quite early in the development phase of the program.

PRELAUNCH FIELD OPERATIONS

When all the environmental tests and calibrations are completed at the laboratory, the satellite payload is shipped to the launching site, usually arriving at least 2 or 3 weeks prior to the scheduled launching date. At the launching site the following are performed:

1. Visual inspection and functional performance check to ascertain that no damage occurred in shipment.
2. Mating of the satellite payload to the last-stage rocket motor.
3. Mechanical alignment and dynamic balancing.
4. Formulation of flight-day procedures and minute-to-minute scheduling.
5. Practice operations to check out the procedures and to familiarize the personnel.
6. Mating of the last-stage rocket-and-payload combination with the rest of the vehicle system.
7. Complete electrical testing of the vehicle system to check for mutual interference among equipment collected together for the first time.
8. Simulated prelaunch operations.
9. Countdown prior to actual launching.

Table 11
 Typical Schedule for Satellite Instrument Package Development

Year	First												Second												
	Months	1	2	3	4	5	6	7	8	9	10	11	12	1	2	3	4	5	6	7	8	9	10	11	12
I N S T R U M E N T	Research																								
	Functional Description																								
	Functional Design Finalization																								
	Packaging Design																								
	Fabrication And Assembly																								
	Functional Environmental Test And Design																								
	Payload Assembly (Proof Test Model)																								
F L I G H T P A Y L O A D	Assembly																								
	Sub-System Check																								
	System Check																								
	Environmental Test																								
	Dummy Run																								
Flight Preparation At Launch Site																									
Flight																									

The launching operation for large, long range vehicles requires the close cooperation and support of hundreds of people in many different groups and in widely scattered geographical locations. If any final tests or calibrations must be performed just prior to the launching, the requirements should be stated in writing so that the payload integration agency is aware of the need. Last minute requests should be avoided, since in a tightly planned schedule the request may not be honored or may delay the launch. A large scale field operation has too much inertia, is too expensive, and has too many supporting activities to be diverted at the last minute without causing a chain reaction. The admonition "plan ahead" is particularly appropriate when applied to the field phase of a launching operation. All possible payload servicing should be completed before shipment to the field; and, being the case, a backup payload in a ready-to-go condition should be available at the launching site where it can be quickly substituted in case of failure of the proposed flight payload. The lack of such a space payload may result in costly delays waiting for the launching pad to become available again.

QUANTITY OF DATA

The satellite experimenter must be prepared to reduce and analyze the large quantities of data which result from a satellite experiment. To cite an example, data reduction and analysis for a single rocket flight of only a few minutes duration typically takes from six months to a year. Explorer I transmitted approximately an hour of data per day to each Microlock ground station; Explorer III sent more than two hours of data on each pass. Thus 12 passes per day and 60 days of useful lifetime would yield 1440 hours of cosmic ray data from the magnetic tape recorder alone, plus the temperature, micrometeorite, orbital, ionospheric, atmospheric, and other data. The quantity of data transmission expected from some Scout experiments may far exceed that just cited.

Characteristically, the data handling problem has often been underestimated in the planning and engineering design of a complex experiment, with the result that data reduction is slow and laborious, and interpretation difficult.

ACCESS TO DATA

In any space program, the handling and distribution of scientific data received from the measuring equipment is an extremely important factor. Scientific experiments in space exploration differ significantly from traditional scientific activities, for they cannot be repeated as could the usual laboratory experiment. Therefore, equal access to these newly acquired data provides the only means whereby scientists not associated with the particular program may verify and utilize the new data for further development.

The widest possible participation in space research and exploration should be encouraged in members of the world's scientific community. The extent of this participation will depend on the availability of scientific data.

There is, of course, some time required to convert raw data into significant physical quantities. Time is also needed for preparing and distributing the material. It would appear, then, that the reduced data could not be made generally available in less than a few months after being received in a data reduction laboratory. In this interval, the experimenter assigned to the specific mission will have access to these data, thus protecting in most cases, his prerogative of publishing any new discoveries resulting from the analysis. If the design of the experimental equipment or the idea behind the experiment or the idea behind the experiment is unique, publication of the data could reasonably be delayed until the experimenter has had adequate opportunity to benefit from the results of his designs, inventions, or discoveries.

Those charged with the responsibility for a measurement should be assigned to direct the reduction of the raw data. Within a week or two after the conclusion of the experiment, those in charge should prepare a resume of the data. This brief report should describe the data acquired and note any unusual occurrences evident in such a cursory examination. Such a summary would be available to scientific agencies or publications, and any scientist could determine whether or not the particular data were of sufficient interest for him to request more complete information for study. Such a program for handling data would be most valuable to scientific endeavors by encouraging the widest possible participation and cooperation in the field of space science.

SUMMARY

In order to expedite work on the Scout or similar payloads to be launched by NASA, representative summaries of past projects under the National Aeronautics and Space Administration have been described, along with the present and anticipated capabilities of the ground station network. It is recommended that one of the basic telemetry systems described herein be used. Early selection of a system should be made to insure that the necessary facilities will be available. Correspondence regarding the NASA payload or associated facilities and services should be addressed to the Director, Space Flight Programs, National Aeronautics and Space Administration, Washington 25, D. C., USA.

The varied aspects of designing a space package have been discussed somewhat independently, yet they cannot be considered independent. To assure the success of the mission, a genuine appreciation of all the components as elements of the system must be present. Care must be exercised constantly to provide for complete exchange of information between all contributors to the space package and thus assure complete compatibility between all elements. For space operations the "systems" concept is of the utmost importance, since overlooking the most minute detail can be disastrous to the mission.

ACKNOWLEDGMENTS

As has been emphasized several times in these pages, the successful completion of a space study is achieved through a concentrated team endeavor. This document has been prepared through just such an effort. The experiences described herein belong to many skills and disciplines. It was with gratification that contributions to this document were received from so many individuals representing a number of laboratories and establishments. It would be virtually impossible to express properly the thanks due to each individual who participated in this project, firstly because there were so many, and secondly because they are not all known. Therefore, recognition is shown to all individual contributors by this expression of appreciation to their respective establishments:

NASA - Headquarters Staff,
NASA - Goddard Space Flight Center,

NASA - Langley Research Center,
NASA - Jet Propulsion Laboratory,
NASA - Wallops Station,
NASA - Marshall Space Flight Center,
Space Technology Laboratories.

BIBLIOGRAPHY

Albright, N. W., "Transformation of Earth-Referenced Data to Internal Coordinate Systems," Jet Propulsion Laboratory Progress Report No. 30-5, Pasadena, California, January 30, 1959.

"Antenna Noise Temperature," (Advertisement, Airborne Instruments Laboratory) Proc. IRE 46(5), Part I, May 1958.

Berg, Robert J., "A Review of Seal Materials for Guided-Missile Applications," Jet Propulsion Laboratory Progress Report No. 20-340, Pasadena, California, March 7, 1958.

Blagonravov, A. A., "Some Problems of Providing for Scientific Research on Rockets," Amer. Rocket Soc. J. 30(1):22-27, January 1960.

Bolton, J. G., and Westfold, K. C., "Galactic Radiation at Radio Frequencies, I:100 Mc/s Survey," Australian J. Scientific Res. Series A, 3:19-33, March 1950.

Brockman, M. H., Buchanan, H. R., et al., "Extra-Terrestrial Radio Tracking and Communication," Jet Propulsion Laboratory, External Publication No. 808, Pasadena, California, December 11, 1959.

Butler, C. T., "Final Report on Project ESP-27 to the Working Group on Internal Instrumentation of the Technical Panel on the Earth Satellite Program," Jet Propulsion Laboratory Publication No. 163, Pasadena, California, May 19, 1959.

Butler, C. T., and Baum, W. A., "The Measurement of Integrated Extra-Terrestrial Radiation by Means of a Satellite-Borne Photometer," Jet Propulsion Laboratory Publication No. 151, Pasadena, California, February 11, 1959.

Buwalda, E. P., and Hibbs, A. R., "Satellite Temperature Measurements for 1958 Alpha, Explorer I," Jet Propulsion Laboratory, External Publication No. 481, Pasadena, California, April 23, 1958.

Carr, Russell E., and Hilton, Herbert B., "Simulation of Missile Flights on the Electronic Digital Computer," Jet Propulsion Laboratory Memorandum No. 20-128, Pasadena, California, May 1, 1956.

Carr, Russell E., and Hudson, R. Henry, "Tracking and Orbit-Determination Program of the Jet Propulsion Laboratory," Jet Propulsion Laboratory Technical Report No. 32-7, Pasadena, California, February 22, 1960.

Castruccio, Peter A., "Communications and Navigation Techniques of Interplanetary Travel," In Institute of Radio Engineers Transactions on Aeronautical and Navigational Electronics, ANE-4(4):216-223, December 1957.

Chapman, R. P., and Currie, B. W., "Radio Noise from Aurorae," J. Geophys. Res. 58:363-367, September 1953.

Choate, R. L., "Calibration Records for the Earth Satellite 1958 Gamma," Jet Propulsion Laboratory Publication No. 126, Pasadena, California, June 27, 1958.

Chvojková, E., "Propagation of Radio Waves from Cosmical Sources, Nature 181:105, January 11, 1958.

Clarke, Arthur C., "Electronics and Space Flight," British Interplan. Soc. J. 7(2):49-69, March 1948.

"Description of World Network for Radio Tracking of Space Vehicles," Jet Propulsion Laboratory Publication No. 135, Pasadena, California, July 1, 1958.

Dobies, E. F., "The Equations of Motion of a Tumbling Reentry Body," Jet Propulsion Laboratory Progress Report No. 20-339, Pasadena, California, November 22, 1957.

Eimer, M., and Hiroshige, Y., "Evaluation of Pioneer IV Orbit Determination Program," Jet Propulsion Laboratory Technical Release No. 34-26, Pasadena, California, February 22, 1960.

Eimer, M., Hibbs, A. R., and Stevens, R., "Tracking the Moon Probes," Jet Propulsion Laboratory, External Publication No. 701, Pasadena, California, December 28, 1959.

Faist, G. A., Jr., "First Order Perturbation Method in the Evaluation of Missile System Stability," Jet Propulsion Laboratory Memorandum No. 30-3, Pasadena, California, June 5, 1959.

Friedman, Herbert, "Scientific Instrumentation in IGY Satellites," Electrical Engineering 76(6):470-474, June 1957.

Froehlich, Jack E., and Hibbs, Albert R., "Contributions of the Explorer to Space Technology," Jet Propulsion Laboratory Progress Report No. 20-359, Pasadena, California, September 3, 1958.

Gardner, R., "Final Engineering Report on Antenna Noise Temperature," Airborne Instruments Laboratory Report No. 3304-11, Contract DA-49-170-sc-1547, November 1957.

Gates, C. R., and Johnson, M. S., "A Study of On-Site Computing and Data Processing for a World Tracking Network," Jet Propulsion Laboratory Publication No. 154, Pasadena, California, February 9, 1959.

Hall, J. R., "A Description of Deep Space Net Facilities, Operations, and Capabilities," Jet Propulsion Laboratory Publication No. 30-21, Pasadena, California, December 4, 1959.

Hamilton, R. C., "Space Probe Power Systems Selection and Development," Jet Propulsion Laboratory, External Publication No. 704, Pasadena, California, June 8, 1959. (Not available for distribution.)

Henize, Karl G., "The Baker-Nunn Satellite Tracking Camera," *Sky and Telescope* 16(3):108-111, January 1957.

Hibbs, A. R., ed., "Exploration of the Moon and Planets and Interplanetary Space," Jet Propulsion Laboratory Report No. 30-1, Pasadena, California, April 30, 1959. (Not available for distribution.)

Hibbs, A. R., "The Temperature of an Orbiting Missile," Jet Propulsion Laboratory Progress Report No. 20-294, Pasadena, California, March 28, 1956.

James, Jack N., "Dovap Radio Beacon RM-2," Jet Propulsion Laboratory Progress Report No. 20-313, Pasadena, California, January 15, 1957.

Kalensher, B. E., "Equations of Motion of a Missile and Satellite for an Oblate-Spheroidal Rotating Earth," Jet Propulsion Laboratory Memorandum No. 20-142, Pasadena, California, April 12, 1957.

Kerr, Donald E., ed., "Propagation of Short Radio Waves," M.I.T. Radiation Laboratory Series, 13, New York: McGraw-Hill, 1951.

Kuiper, Gerard P., ed., "The Solar System, (vol. 1) The Sun," Chicago: University of Chicago Press, 1953.

Laitinen, Paul O., and Haydon, George W., "Analysis and Predictions of Sky Wave Fields Intensity," Radio Propagation Agency Technical Report No. 9, Ft. Monmouth, New Jersey, August 1950.

Lesh, H. F., "Multi-Dimensional Least-Squares-Curve Fitting and Separation of Variables," Jet Propulsion Laboratory Memorandum No. 30-1, Pasadena, California, February 27, 1959.

Levy, I. J., and Poland, W. B., "Vanguard Telemetry Data Reduction System," in U. S. Naval Research Laboratory, Report of NRL Progress, April 1959.

Linnes, K., and Rehtin, E., "Application of Microlock to IGY Satellite Instrumentation," Jet Propulsion Laboratory External Publication No. 404, Pasadena, California, July 26, 1957.

Lorell, J., Carr, R. E., and Hudson, R. H., "The Jet Propulsion Laboratory Lunar Probe Tracking and Orbit Determination Program," Jet Propulsion Laboratory Technical Release No. 34-16, Pasadena, California, March 10, 1960.

Lorens, Charles S., "The Doppler Method of Satellite Tracking," Jet Propulsion Laboratory Report No. 30-2, Pasadena, California, March 30, 1959.

Manning, E., and Dubin, M., "Satellite Micrometeorite Measurements," IGY World Data Center A for Rockets and Satellites," IGY Satellite Report Series, No. 3, 1 May 1958, National Academy of Sciences, Washington, D. C.

Marner, Gene R., "Atmospheric Attenuation of Microwave Radiation," Institute of Radio Engineers Convention Record, Antennas and Propagation, Part I: Antennas, 1955.

Martin, Ben D., "A Coherent Minimum-Power Lunar Probe Telemetry System," Jet Propulsion Laboratory External Publication No. 610, Pasadena, California, May 12, 1959.

Martin, Ben D., "On Threshold Improvement in a FM Subcarrier System," Jet Propulsion Laboratory External Publication No. 809, Pasadena, California, December 18, 1959.

Matthews, Whitney, "Earth Satellite Instrumentation," Electrical Engineering 76(7):562-567, July 1957.

Matthews, Whitney, "Telemetry in Earth Satellites," Electrical Engineering 76(11):976-981, November 1957.

Mazur, Daniel G., "Telemetry and Propagation Problems of Placing the Earth Satellite in its Orbit," Proc. IRE 44(6):752-754, June 1956.

McDonald, W. S., "Satellite Tracking from Several Coordinated Doppler Receiving Stations," Jet Propulsion Laboratory External Publication No. 554, Pasadena, California, September 5, 1958.

Mengel, John T., "Minitrack System Design Criteria," Electrical Engineering 76(8):666-672, August 1957.

Mengel, John T., "Tracking the Earth Satellite, and Data Transmission by Radio," Proc. IRE 44(6):755-760, June 1956.

Merrick, W. D., Frazer, R. E., Valencia, C., and Stoller, F. W., "The Techniques, Equipment, Equations and Data Reduction Procedures Used in the Alignment, Checkout, and Evaluation of the 85-ft. Dish Radio Telescope Antenna at JPL Goldstone Tracking Site," Jet Propulsion Laboratory Publication No. 30-9, Pasadena, California, September 7, 1959. (Not available for distribution.)

Millman, George H., "An Analysis of Tropospheric, Ionospheric, and Extra-Terrestrial Effects on V.H.F. and U.H.F. Propagation," Technical Information Series Report No. R56EMH31, Oct. 1956, General Electric Co., Syracuse, New York.

Millman, George H., "Atmospheric Effects on V.H.F. and U.H.F. Propagation," Proc. IRE 46(8):1492-1501, August 1958.

Moe, C. R., "Ground to Space Propagation Phenomena," National Conference on Aeronautical Electronics, Proceedings, May 12-14, 1958, Dayton, Ohio. (Sponsored by the Institute of Radio Engineers.)

Mueller, George E., "Telebit - An Integrated Space Navigation and Communication System," *Astronautics* 5(5):26-27, 88-96, May 1960.

Muhleman, Duane, "Satellite Orbit Determination and Prediction Utilizing J.P.L. Goldstone 85-Foot Antenna and the J.P.L. Tracking Program," Jet Propulsion Laboratory Technical Release No. 34-27, Pasadena, California, February 23, 1960.

Newell, H. E., Jr., and DeVore, Charles, "Electricity in the International Geophysical Year," *Electrical Engineering*, v. 76, no. 5, May 1957: 370-375.

Nichols, Myron Hiram and Rauch, Lawrence L. *Radio Telemetry*. 2d ed. New York, Wiley, 1956.

"1958 NASA/USAF Space Probes (Able I) Final Report," vols. 1, 2, 3, and 4, Space Technology Laboratories, Inc., NASA Memo 5-25-59W, February 18, 1959. (Vol. 4 Confidential)

Noise Factor and Noise Temperature. (Advertisement, Airborne Instruments Laboratory). In Institute of Radio Engineers. Proceedings, v. 46, no. 1, Jan. 1958: 2A.

"Operational and Facility Requirements Tentatively Proposed for the NASA Deep Space Instrumentation Facility Located at Island Lagoon, Woomera Range, Australia," Jet Propulsion Laboratory Publication No. 30-20, Pasadena, California, November 1959. (Not available for distribution.)

Piddington, J. H., and Trent, G. H., "A Survey of Cosmic Radio Emission at 600 Mc/s," *Australian J. Physics* 9:481-493, December 1956.

Pilkington, W. C., "Effects of Irradiation on Transistors," Jet Propulsion Laboratory External Publication No. 366, Pasadena, California, April 1, 1957.

"Proposal for Modification of the State University of Iowa Cosmic Ray Experiment for the Jupiter C Vehicle," Jet Propulsion Laboratory Publication No. 115, Pasadena, California, December 2, 1957.

Rechtin, Eberhardt, "Communication Techniques for Space Exploration," IRE Transactions on Space Electronics and Telemetry, Set 5, No. 3, September 1959, pp. 95-98.

Rechtin, E., and Jaffee, R., "Design and Performance of Phase Lock Loops Capable of Near Optimum Performance Over a Wide Range of Input Signal and Noise Levels," Jet Propulsion Laboratory Progress Report No. 20-243, Pasadena, California, December 1, 1954.

Rechtin, E., Stevens, R., and Victor, W. K., "Design for Space Communication," Jet Propulsion Laboratory Technical Memo, July 7, 1958.

Richard, Victor W., "Doploc Tracking Filter," Ballistic Research Laboratory Memorandum Report No. 1173, October 1958.

Riddle, F. M., Mandrell, W. L., et al., "Transistorized Telemetering Developments and Design Criteria of the Jet Propulsion Laboratory," Jet Propulsion Laboratory Report No. 20-108, Pasadena, California, May 1, 1957.

Robillard, G., "The Explorer Rocket Research Program," Jet Propulsion Laboratory Publication No. 145, Pasadena, California, October 31, 1958.

Rochelle, R. W., "Earth Satellite Telemetry Coding System," Electrical Engineering 76(12):1062-1065, December 1957.

Sampson, William F., Richter, Henry L., and Stevens, Robertson, "Microlock: A Minimum-Weight Radio Instrumentation System for a Satellite," Jet Propulsion Laboratory Progress Report No. 20-308, Pasadena, California, November 14, 1956.

Schaefer, D. H., "Magnetic Core Event Counter for Earth Satellite Memory," Electrical Engineering 77(1):52-56, January 1958.

Scharla-Nielsen, Hans, "Space Ship Telemetry," National Symposium on Telemetering, Philadelphia, April 14-16, 1957, Proceedings. Abstracted in Institute of Radio Engineers. Transactions on telemetry and remote control, vol. TRC-3, No. 1, April 1957.

Scharla-Nielsen, Hans, "Techniques for Interplanetary Telemetering," National Conference on Aeronautical Electronics Proceedings, May 12-14, 1958, Dayton, Ohio: pp. 247-250. (Sponsored by the Institute of Radio Engineers.)

Schilling, G. F., and Sterne, T. E., "Densities and Temperatures of the Upper Atmosphere Inferred from Satellite Observations," J. Geophys. Res. 64(1):1-4, January 1959.

Schroeder, C. A., Looney, C. H., Jr., and Carpenter, H. E., Jr., "Phase Measurement," U. S. Naval Research Laboratory Report No. 4995, Project Vanguard Report No. 18, Minitrack Report No. 1, July 26, 1957.

Schroeder, C. A., Habib, E. J., and Silvester, W. R., "Time Standard," U. S. Naval Research Laboratory Report No. 5227, Project Vanguard Report No. 36, Minitrack Report No. 8, October 22, 1958.

Seehof, J. M., and Washburn, B. W., "Processing and Presentation of Data from Outer Space. I. Pioneer Probe," 1959 National Telemetering Conference, May 1959.

Shipley, W. S., "Evaluation of the Absorptivities of Surface Materials to Solar and Terrestrial Radiation, with Plots of the Reflectances (at Wavelengths of 0.4 to 25 μ) for Ten Sample Materials Including Two Types of Fibrous-Glass-Reinforced Plastic," Jet Propulsion Laboratory Progress Report No. 20-319, Pasadena, California, April 11, 1957.

Simas, V. R., "The Satellite Telemetry Receiver System," U. S. Naval Research Laboratory Report No. 5065, Project Vanguard Report No. 24, Minitrack Report No. 4, January 20, 1958.

Simas, V. R., and Bartholomew, C. A., "Receiver System," U. S. Naval Research Laboratory Report No. 5055, Project Vanguard Report No. 23, Minitrack Report No. 3, December 6, 1957.

Siry, J. W., "The Vanguard IGY Earth Satellite Program," Fifth General Assembly of CSAGI, Moscow, 1958.

Smith, George O., "Radio Communications Across Space—Ship-to-Ship and Ship-to-Planet," British Interplan. Soc. J. 12(1):13-23, January 1953.

Smithsonian Astrophysical Observatory, "Bulletin for Visual Observers of Satellites, No. 1," Sky and Telescope vol. 15, no. 9, July 1956.

Statler, I. C., "Equations of Motion for an Elastic Nonspinning Missile Acted Upon by Thrust and Aerodynamic Forces," Jet Propulsion Laboratory Progress Report No. 20-281, Pasadena, California, March 21, 1956.

Sterne, Theodore E., "The Density of the Upper Atmosphere," In: "Some Preliminary Reports of Experiments in Satellites 1958 Alpha and 1958 Gamma," IGY Satellite Report Series, No. 3, May 1, 1958, pp. 10-14.

Taber, John E., "Able 3 Payload Design," IRE Transactions on Military Electronics, vol. MIL-3(4):143-149, October 1959.

Theory and Analysis Staff, Goddard Space Flight Center, "Interim Definitive Orbit for the Satellite 1959 Alpha, Vanguard II," NASA Technical Note D-411, 1960.

Townsend, John W., Jr., "Instrumentation for Space Science Research," Institute of the Aeronautical Sciences Paper no. 59-127.

"Trajectory Design Methods," Jet Propulsion Laboratory Publication No. 30-18, Pasadena, California, November 1959.

U. S. Department of the Army, White Sands Proving Grounds, "Telemetry Standards for Guided Missiles," Inter-Range Instrumentation Group Steering Committee Document No. 103-56, October 1956.

Van Allen, James A., "Radiation Belts Around the Earth," Scientific American 200(3):39-47, March 1959.

Van Allen, James A., McIlwain, Carl E., and Ludwig, George H., "Radiation Observations with Satellite 1958 Epsilon," J. Geophys. Res. 64(3):271-286, March 1959.

Victor, W. K., "Precision Frequency Control, a Communications Requirement of the Space Age," Jet Propulsion Laboratory External Publication No. 627, Pasadena, California, May 13, 1959.

APPENDIX A

**PRELIMINARY ENVIRONMENTAL
TEST SPECIFICATIONS FOR SCOUT
PAYLOADS**

THERMAL VACUUM TEST

Prototype Payload

High Temperature Test

Vacuum - The chamber shall be evacuated to a pressure of 1×10^{-4} mm Hg or less with the payload remaining at simulated launch temperature.

Temperature - The walls of the temperature-vacuum chamber and other radiant energy sources shall be maintained at a temperature such that a selected point in the payload attains a minimum temperature 10°C higher than the maximum predicted temperature distributions shall be reasonably representative of actual flight conditions.

*Duration** - The test shall last a minimum of seven days of continuous-duty-cycle operation.

Payload Operation - The payload shall be operated in a duty cycle typical of the launch phase during the pressure evacuation from atmospheric to the stable pressure specified above. After reaching a stable pressure, the payload shall be operated in a duty cycle typical of space flight. Recharging the batteries by means of the solar cells and light sources within the chamber is considered desirable. If facility limitations preclude this type of operation, then an external charging source for the flight batteries may be substituted for the solar cells as a power source.

Low Temperature Test

Vacuum - The chamber shall be maintained at a pressure of 1×10^{-4} mm Hg or less.

Temperature - The walls of the temperature-vacuum chamber and other radiant energy sources shall be maintained at a temperature such that a selected point in the payload attains a minimum temperature of 10°C lower than the minimum predicted temperature.

*For payloads with a mission life less than seven days, the test duration shall be 1.25 times the mission life or seven days, whichever is less. Expendable power sources may be replaced after each test.

The temperature distributions shall be reasonably representative of actual flight conditions.

*Duration** - If this low temperature test is a direct continuation of the previous high temperature test, without opening of the chamber, then the duration shall be not less than three days. At least two days shall be at the temperature specified above. If the chamber is opened, the test shall last five days from the time stable conditions are re-established.

Payload operation - After reaching a stable pressure, the payload shall be operated in a duty cycle typical of space flight. Recharging the batteries by means of the solar cells and light sources within the chamber is considered desirable. If facility limitations preclude this type of operation, an external charging source for the flight batteries may be substituted for the solar cells as a power source.

Flight Payload

High Temperature Test

Vacuum - The chamber shall be evacuated to a pressure of 1×10^{-4} mm Hg or less with the payload remaining at simulated launch temperature.

Temperature - The walls of the temperature-vacuum chamber and other radiant energy sources shall be maintained at a temperature such that a selected point in the payload attains a minimum temperature equal to the maximum predicted temperature. The temperature distributions shall be reasonably representative of actual flight conditions.

Duration - The test shall last for three days or for the mission life, whichever is less.

Payload operation - The payload shall be operated in a duty cycle typical of the launch phase during the pressure evacuation from atmospheric to the stable pressure specified above. After reaching a stable pressure, the payload shall be operated in a duty cycle typical of space flight. Recharging the batteries by means of the solar cells and light sources within the chamber is considered desirable. If facility limitations preclude this type of operation, an external charging source for the flight batteries may be substituted for the solar cells as a power source.

Low Temperature Test

Vacuum - The vacuum shall be maintained at 1×10^{-4} mm Hg or less.

Temperature - The walls of the temperature-vacuum chamber and other radiant energy sources shall be maintained at a temperature such that a selected point in the payload attains a minimum temperature equal to the minimum predicted temperature.

*For payloads with a mission life less than seven days, the test duration shall be 1.25 times the mission life or seven days, whichever is less. Expendable power sources may be replaced after each test.

The temperature distributions shall be reasonably representative of actual flight conditions.

Duration - If this low temperature test is a direct continuation of the previous high temperature test, without opening of the chamber, then the duration shall be for not less than two days or for the mission life, whichever is less. At least one day of this duration must be at the temperature specified above. If the chamber is opened, the test shall last for three days from the time stable conditions are reestablished or for the mission life, whichever is less.

Payload operation - After reaching a stable pressure, the payload shall be operated in a duty cycle typical of space flight. Recharging the batteries by means of the solar cells and light sources within the chamber is considered desirable. If facility limitations preclude this type of operation, an external charging source for the flight batteries may be substituted for the solar cells as a power source.

VIBRATION TESTS

General

The vibration tests given herein are intended to provide assurance that a given payload will survive the expected flight environments, and are applicable to the complete payload in its powered-flight configuration. The prototype test levels are arbitrarily increased by 50 percent to provide a factor of safety in design. Since vibration is an induced environment the levels are dependent upon the vehicle characteristics, interstage connections, and payload characteristics. There may be peculiar conditions for particular payloads which will warrant modification of the general tests cited herein.

Applicability

The vibration tests are based principally on the excitations generated by use of the ABL-X-248 rocket motor. The vibration excitation shall be applied at the interstage connection between the final stage and the payload. In establishing the test levels some allowance has been made for excitation generated by earlier stages, aerodynamic disturbances, and handling and transportation effects. The resonance test is required because of unique resonance burning observed in the X-248 rocket motor. Modification of this specification will be made as better data become available. Shock tests, as applicable, should be made immediately following the vibration tests.

Prototype Payload

The payload shall be subjected to vibration in three orthogonal directions, one of which shall be parallel to the thrust axis, in accordance with the following schedule.

Sinusoidal Vibration

Frequency Range (cps)	Amplitude (g rms)*	
	Thrust Axis	Transverse Axes
5 - 50	1.5	0.6
50 - 500	7.5	1.5
500 - 2000	15	3
2000 - 5000 [†]	60	20

*Amplitude limited to 1.27 centimeters (0.5 inch) peak-to-peak.

[†] Tests in this frequency band may be omitted if the structural transmissibility is negligible.

Sweep rate - Approximately two octaves per minute.

Duration - Approximately 5 minutes each direction Total time, 15 minutes.

Random Vibration

Direction	Frequency Band (cps)	Spectral Density (g ² /cps)	Amplitude (g rms)
Thrust Axis	20 - 2000	0.07	11.5
Transverse Axes	20 - 2000	0.07	11.5

Duration - 4 minutes each direction. Total time, 12 minutes.

Resonance

Apparent weight - The apparent weight of the prototype should be measured at 600 cps. The amplitude values given below are based on an apparent weight of 2.3 kilograms (5 pounds) at this frequency. Correction of the amplitude in inverse proportion to the actual apparent weight should be made, but in no case shall the amplitudes be greater than those given.

600-cps Vibration

Direction	Frequency (cps)	Amplitude (g rms)
Thrust Axis	550 - 650	60
Transverse Axes	550 - 650	15

Duration - 30 seconds in each direction. Total time, 1.5 minutes.

Payload Operation

The payload shall be in an operational status normal to powered flight during the vibration. After three schedules have been run, the payload shall be checked for complete electrical and mechanical operation. A detailed examination shall be made for evidence of cracks, wear, loose parts and similar items.

Flight Payload

The payload shall be subjected to vibration in three orthogonal directions, one of which shall be parallel with the thrust axis, in accordance with the following schedule:

Sinusoidal Vibration

Frequency Range (cps)	Amplitude (g rms)*	
	Thrust Axis	Transverse Axes
5 - 50	1	0.4
5 - 500	5	1
500 - 2000	10	2
2000 - 5000 [†]	40	8

*Amplitude limited to 1.27 centimeters (0.5 inch) peak-to-peak.

[†] Tests in this frequency band may be omitted if the structural transmissibility is negligible.

Sweep rate - Approximately four octaves per minute.

Duration - Approximately 2-1/2 minutes in each direction. Total time, 7-1/2 minutes.

Random Vibration

Direction	Frequency Band (cps)	Spectral Density (g ² /cps)	Amplitude (g rms)
Thrust Axis	20 - 2000	0.03	7.7
Transverse Axes	20 - 2000	0.03	7.7

Duration - 2 minutes in each direction. Total time, 6 minutes.

Resonance

Apparent weight - The amplitudes given are based on an apparent weight of 2.3 kilograms (5 pounds) at 600 cps. Correction of the amplitudes in inverse proportion to the actual apparent weight as measured on the prototype should be made, but in no case shall the amplitude be greater than that given below.

600-cps vibration

Direction	Frequency (cps)	Amplitude (g rms)
Thrust Axis	550 - 650	40
Transverse Axes	550 - 650	8

Duration - 15 seconds in each direction. Total time, 45 seconds.

Payload Operation

The payload shall be in an operational status normal to powered flight during the vibration. After the three schedules have been run, the payload shall be checked for complete electrical and mechanical operation. A detailed examination shall be made for evidence of cracks, wear, loose parts and similar conditions.

ACCELERATION AND SPIN**Prototype Payload**Thrust Axis Acceleration

General - The payload, in its powered flight configuration, shall be subjected to an acceleration-time profile, measured at its center of gravity, which corresponds as nearly as practicable to the expected flight profile. The acceleration at the center of gravity of the payload shall be 1-1/2 times the expected or computed value, and the variation along the axis shall not exceed -15 percent at the forward end and +10 percent at the aft end.

Payload operation - The payload shall be in an operational status normal to powered flight during this test. After the test it shall be checked for complete operation.

Lateral Acceleration (Normal to Thrust Axis)

Direction - The lateral force shall be applied in the direction most likely to produce damage. A second test shall be conducted with the force at 90 degrees to this direction.

Magnitude - The acceleration shall be 1-1/2 times the maximum expected from flight maneuvers. Variation in acceleration from that at the center of gravity shall not exceed ± 10 percent.

Duration - The acceleration shall be maintained for at least one minute.

Payload operation - The payload shall be in an operational status normal to powered flight. After the test it shall be checked for complete operation.

Spin

General - The payload shall be subjected to a spin-rate-time profile which corresponds to the expected roll rates in flight, as nearly as practicable, except that each peak spin-rate shall be 1-1/4 times the expected or calculated flight value. The terminal spin-rate - such as that at the end of powered flight, after separation from the booster, or after despin as the case may be - shall be maintained for sufficient time to permit operation of the payload through its normal duty cycle for ten repeated cycles. If a cyclic operating performance is not appropriate, this time period shall be not less than one minute.

Payload operation - The payload shall be in an operational status normal to powered flight as the test is begun. After the terminal spin rate is achieved, the payload shall be operated in a duty cycle which simulates that to be employed in free flight for ten repeated cycles. The time increment in the duty cycle may be shortened to 30 seconds for any period of unvarying conditions.

Combined Acceleration and Spin

The combination of acceleration and spin is a realistic environment which might effect payload operations. The simulation of the combination on the prototype payload may be substituted for the Thrust Axis Acceleration Test and the Spin test described above if appropriate facilities are available. If it is impractical to check the prototype payload under combined conditions, then combined tests shall be conducted on subassemblies or components deemed to be critical under the influence of these combined forces.

Flight Payload

Acceleration and spin tests are not normally required on flight payloads. However, such tests as indicated for the prototype payload but at the expected flight values may be required at the direction of the Goddard Space Flight Center for new or unproven designs, or when the prototype tests have indicated an unusually high sensitivity to failure under these environments.