

394 826

INNOVATIVE CONTAMINATION CERTIFICATION OF MULTI-MISSION FLIGHT HARDWARE

Patricia A. Hansen
NASA, Goddard Space Flight Center

David W. Hughes, Kristina M. Montt, and Jack J. Triolo
Swales Aerospace

ABSTRACT

Maintaining contamination certification of multi-mission flight hardware is an innovative approach to controlling mission costs. Methods for assessing ground induced degradation between missions have been employed by the Hubble Space Telescope (HST) Project for the multi-mission (servicing) hardware. By maintaining the cleanliness of the hardware between missions, and by controlling the materials added to the hardware during modification and refurbishment both project funding for contamination recertification and schedule have been significantly reduced. These methods will be discussed and HST hardware data will be presented.

INTRODUCTION

The Hubble Space Telescope (HST) was designed to be periodically serviced on-orbit during its 15 year mission. The Space Transportation System (STS) serves as the platform from which the HST is serviced and servicing carriers provide an interface from the Orbiter to the scientific instruments and orbital replacement units. While the servicing carriers are configured for each mission to accommodate mission unique orbital replacement units, the basic carrier (structure and support airborne flight equipment) remains unchanged. The HST servicing carriers were flown during the HST Servicing Mission 1 (SM1), STS-61 (December 1993) and the HST SM2, STS-82 (February 1997). Currently, the servicing carriers are being reconfigured for the HST SM3 (May 2000).

Due to the extreme sensitivity of the HST, scientific instrument, orbital replacement unit optics to molecular and particulate contamination, all aspects of a servicing mission are assessed for subsequent contamination effects to these optical elements. The assessment begins with the basic requirements for the telescope and extends to each mission component. Because of the large surface area of the servicing carriers, both outgassing levels and surface cleanliness levels are controlled during all aspects of integration, test, launch activities, and on-orbit operations.

By maintaining the cleanliness of the hardware between missions, and by controlling the materials added to the hardware during modification and refurbishment both project funding for contamination recertification and schedule have been significantly reduced. These methods will be discussed and HST hardware data will be presented.

SERVICING CARRIER DESCRIPTION

The HST servicing carriers include: the Solar Array Carrier (SAC), the Orbital Replacement Unit Carrier (ORUC), the Flight Support System (FSS), the Rigid Array Carrier (RAC), the Second Axial Carrier (SAC), and the Multi-Use Lightweight Experiment (MULE). The carriers are shown in Figures 1-6 and the servicing mission manifest is illustrated in Table 1. The 15' long x 15' wide x 15' high Solar Array Carrier functioned as a load isolation system for the Solar Array 2 during the First Servicing Mission. For the Second Servicing Mission, the Solar Array Carrier was reconfigured, renamed the Second Axial Carrier, and provided a load isolation system for the Axial Scientific Instrument Protective Enclosure which in turn provided a contamination and thermally controlled environment for the Near Infrared Cosmic Origins Spectrograph (NICMOS).

Table 1. Carrier Mission Manifest

Carrier	SM1	SM2	SM3	SM4
Flight Support System	✓	✓	✓	✓
Multi-Use Lightweight Explorer			✓	
Orbital Replacement Unit Carrier	✓	✓	✓	✓
Rigid Array Carrier			✓	
Second Axial Carrier		✓		
Solar Array Carrier	✓			
Unidentified Carrier(s)				✓

For the Third Servicing Mission, the Rigid Array Carrier, Orbital Replacement Unit Carrier, Flight Support System, and Multi-Use Lightweight Explorer have been manifested and are shown in the flight configuration in Figure 7. The Rigid Array Carrier and Orbital Replacement Unit Carrier are Spacehab pallets that have been modified to provide scientific instrument and orbital replacement unit stowage for the servicing mission. The 12' long x 15' wide x 15' high Rigid Array carrier functions as a load isolations system for the Solar Array 3 and will be used to stow the replaced Solar Array 2 during two extravehicular activity (EVA) days. The most contamination sensitive carrier is the 12' long x 15' wide x 15' high ORUC. The Orbital

Replacement Unit Carrier provides a load isolation system for an Axial Scientific Instrument Protective Enclosure (SIPE) and the Fine Guidance Sensor SIPE. These SIPEs, collectively known as the BISIPE, provide a contamination and thermally controlled environment for a stowed scientific instrument and Fine Guidance Sensor. Because of the optical sensitivity of the NICMOS, scientific instruments, and Fine Guidance Sensors, the Second Axial Carrier and the Orbital Replacement Unit Carrier are the most contamination sensitive carriers. The 5' long x 15' wide x 15' high Flight Support System is used as the maintenance platform to berth the HST to the Orbiter during the EVAs. The 5' long x 15' wide x 15' high Multi-Use Lightweight Explorer provides stowage for orbital replacement units and is shown with the Aft Shroud Cooling System radiators mounted.

The SIPEs provide a thermal environment equivalent to that inside the HST. The warm thermal environment not only ensures that the scientific instruments and Fine Guidance Sensors will remain within their temperature limits during the EVA. This also ensures that any outgassing inside the SIPEs, which would otherwise affect the optical performance, will not condense on the scientific instruments or Fine Guidance Sensors. The SIPEs also provide a purge interface, which allows the scientific instruments and Fine Guidance Sensors to be purged until launch (T-0). Vent restrictor plates (37 μm mesh) inhibit particulate contamination of the scientific instruments or Fine Guidance Sensors during all ground and launch activities.

Due to the diversity of the orbital replacement units and scientific instruments manifested for each flight, the carriers provide the most flexible stowage capability for the servicing mission hardware. Because of this flexibility, two carriers will be flown for all planned servicing missions – the Orbital Replacement Unit Carrier and the Flight Support System. Because of the planned multiple missions of the Orbital Replacement Unit Carrier and Flight Support System over a decade, the HST contamination control program looked at the “big picture” to determine the most cost effective contamination control approach that both provides the needed contamination controlled environment for the scientific instruments and Fine Guidance Sensors while controlling cost. Because of the excessive cost and schedule required to recertify the molecular outgassing levels of the individual carriers for each servicing mission, the HST contamination control program looked at innovative methods to alleviate the recertification of the carriers for each mission. Controlling the material added to the carriers and individually certifying new hardware prior to integration onto the carrier accomplished this. The storage, integration and test environment is also controlled, with the carriers spending the majority of these activities in a Class 10,000 (M 5.5) cleanroom. When not in the cleanroom, the carriers are double bagged. During storage, the carriers are cleaned periodically to maintain the surface cleanliness levels.

SERVICING MISSION CONTAMINATION PROGRAM

The servicing missions are complex and require that the telescope be exposed to the Orbiter (including carriers) environment during the installation of the scientific instruments and Fine Guidance Sensors into the HST Aft Shroud. This exposure is typically from one to seven hours. During the scientific instrument installation, one EVA crewmember (i.e., an astronaut) enters the Aft Shroud to guide both the old instrument out of the telescope and the new instrument into the telescope. Because of this exposure and to maintain the Ultraviolet (UV) capabilities of the

telescope, the contamination requirements placed on both the Orbiter and carriers are quite stringent. While one might argue that the scientific instrument is the most contamination sensitive element, in reality, maintaining the low contamination flux in the telescope's optical path is the primary contamination requirement.

Neither the Orbiter nor the extravehicular mobility unit (space suit) contamination levels can be verified by methods other than by visual examination. Outgassing levels are not measured, and by the nature of Orbiter, many materials generally not used around sensitive hardware are used for performance. Where possible, materials which are verified to be high outgassing, which would not impact the Orbiter performance have been removed for the HST servicing missions. In addition, a best effort is made to control contamination during Orbiter processing activities.

Ground processing activities, Orbiter integration and the overall mission activities are assessed for subsequent contamination effects to the HST and the scientific instruments and Fine Guidance Sensors for each servicing mission. This assessment begins with the basic requirements for the HST and extended to each mission component. An overall contamination budget is developed which allocates acceptable degradation among mission phases. The servicing mission cleanliness requirements and budgets are set with respect to hardware line-of-sight views of sensitive surfaces, purging of the scientific instruments for sustaining critical element functional lifetime, Orbiter and EVA effects, Orbiter cleanliness, cleanroom protocol, and Kennedy Space Center integration activities.

Prior to each servicing mission, the HST contamination control philosophy is reviewed to determine its applicability to reflown carrier hardware, new scientific instruments, new orbital replacement units, and HST optical performance. The current contamination control program evolved from both the SM1 and SM2 program and has been updated for SM3 based on post-mission results (1, 2). The servicing carriers met stringent outgassing requirements prior to SM1, and the integrity of the outgassing certification of the carriers have been maintained for both SM2 and SM3. Only new carriers, and significantly reworked contamination sensitive hardware, such as the SIPEs, are certified to the required outgassing rate prior to a servicing mission.

Telescope and Scientific Instrument Requirements

To maintain the UV performance of the telescope and therefore, the scientific instruments, the telescope contamination requirements address both the surface level cleanliness of the Primary and Secondary mirror and the allowable outgassing flux rate for the telescope's optical path (known as the hub area). The scientific instrument requirements are based on the optical sensitivity of the scientific instrument.

Primary and Secondary Mirrors

The particulate contamination requirements are less than a 5 percent maximum area coverage for the summation of the Primary and Secondary Mirrors. This was determined pre-launch by measuring the obscuration ratio of optical witness mirrors. To date, no scientific instrument data has indicated that this requirement has been violated.

The molecular contamination requirement is less than a 10 percent decrease in reflectance at Lyman-Alpha (1216 Angstrom) wavelengths on the Primary and Secondary Mirrors after 5 years on-orbit. This was determined pre-launch by measuring optical witness mirrors. Neither integrated nor periodic measurements indicated that this requirement had been violated. The initial outgassing criteria was 4.33×10^{-13} g/cm²-s flux as measured with the mirrors at nominal operating temperatures and the collector at -20°C. The optical witness mirror reflectance degradation also needed to be less than 3 percent at Lyman-Alpha wavelengths.

Hub Area

The light path of the telescope is referred to as the hub area. The four axial and one radial scientific instrument apertures, the three Fine Guidance Sensor apertures and the back of the primary mirror define this area. To control the amount of contamination entering this area and to prevent cross contamination, contamination requirements are flowed down to the scientific instruments and Fine Guidance Sensors. The outgassing rate from an instrument aperture or a Fine Guidance Sensor aperture into the hub area cannot exceed 1.32×10^{-9} g/sec. The Fine Guidance Sensor's outgassing rate is measured with the instrument at worst case hot operational temperatures (approximately 25°C) and the collector at -65°C. Similarly, the surface level contamination requirements for any item entering the telescope are Level 400B per MIL-STD 1246.

Aft Shroud

Four axial scientific instruments are installed in the Aft Shroud. To control the amount of contamination entering this area and to prevent cross contamination, the scientific instruments must meet minimum surface level cleanliness and outgassing requirements. The scientific instrument exterior surface cleanliness level shall not exceed 400B per MIL-STD 1246. The outgassing requirement measured at the scientific instruments aft vent cannot exceed an equivalent rate of 1.56×10^{-9} g/hr-cm² based on the exterior surface area of the instrument. This outgassing rate is measured with the scientific instrument ten degrees above the worst case hot operational temperatures and the collector at -20°C. While the largest percentage of the outgassed products is vented through the telescope's aft vents, there is a small probability that an instrument could increase the flux in the hub area, affecting the telescope's performance.

Scientific Instruments and Fine Guidance Sensors

The scientific instruments and Fine Guidance Sensors have individual contamination requirements based on their optical sensitivity. For example, scientific instruments viewing in the UV wavelength regions would have the most sensitivity to molecular contamination. While those scientific instruments viewing in the infrared wavelength regions would have the greatest sensitivity to particulate contamination. The scientific instruments and Fine Guidance Sensors are delivered to NASA with verification of internal contamination levels. These levels are maintained throughout the integration, test and launch activities through contamination controls such as a gaseous Nitrogen purge.

Orbiter and EVA Effects

In addition to many hardware cleanliness requirements, numerous analyses were performed for the Orbiter environment and EVA contamination impacts. These analyses provided critical assessments for controlling on-orbit contamination generating activities and provided the necessary quantitative details for imposing ground processing requirements for the Orbiter. The major analyses include plume impingement, waste/water dumps, SIPE, extravehicular mobility unit (EMU), Orbiter reboost, and HST configuration changes including deployed solar arrays. These analyses represent the core of the cleanliness concerns associated with the shuttle and EVAs. In addition to the analysis for the Orbiter, cleaning requirements were assessed and levied on the Orbiter payload bay. To quantify the effects of the crew compartment on subsequent EVAs relative to the particulate environment, two witness plates were flown on STS-51. These results were used to determine crew cabin and EMU (space suit) cleanliness requirements (4).

The analysis of the Orbiter plume impingement assessed the degradation of the HST surfaces due to gaseous and liquid droplet impingement from thruster firings during maneuvers and station keeping operations. Byproducts from the incomplete combustion, such as monomethyl hydrazine (MMH)-nitrate, can have detrimental effects on contamination sensitive and thermal control surfaces. The station keeping and attitude adjustments considered were low-Z and norm-Z modes. Because the byproduct mass flux in the Norm-Z thruster firing case was significant, limitations were imposed for Orbiter operations.

Significant droplets are formed during Orbiter waste/water exhaust. These droplets may pose a potential threat to the HST during EVA operations when the telescope's Aft Shroud doors are open. The estimation of the maximum effluent released during these dumps is approximately 320-lbm for each dump. Since this represents a significant amount of released material during the HST servicing operations, restrictions were set in both the First Servicing Mission and Second Servicing Mission flight rules. All dumps were constrained 120 minutes prior to and during EVA to preclude potential impingement on critical area of the HST.

Because the SIPEs provided cleanliness protection during launch, ascent, and on-orbit operations for the scientific instruments, a separate analysis was performed to assess contamination impacts. The primary objective was to examine impacts due to the particle control redistribution within the SIPEs, molecular flow, and moisture control within the SIPEs. All of the elements of this analysis accounted for any degradation to the scientific instruments during these phases.

During an EVA, the amount and type of contamination emitted by the astronaut was considered a threat to optical surfaces on the HST. In addition, the astronaut was in close proximity (e.g., line of sight) to the scientific instruments and Aft Shroud. The main concern was contamination contributions from the EMU (i.e., space suit). The EMU exhaust was analyzed and assessed for molecular and particulate contributions. The main byproduct of the EMU exhaust was estimated to be 1 to 1.5 lb/hr of water vapor/ice. Because the sensitive HST surface temperatures were above the water condensation temperature for a low pressure environment, no contaminant depositions from the EMUs were expected.

Orbiter Payload Bay Cleanliness Requirements

The Orbiter payload bay liner and thermal control blankets (forward and aft bulkheads, Bays 12 and 13) provides thermal control to the payload and may be flown on many mission. A reflight liner section or thermal control blankets may provide a large outgassing source to a payload if contaminated by a previous payload on another mission. As this potential outgassing source could not be quantified or outgassing specified identified, a new, unflown payload bay liner was requested for the entire payload bay. The thermal blankets could not be replaced due to excessive cost; however, they were cleaned with an isopropyl alcohol (IPA)/deionized (DI) water mixture and verified to have no significant fluorescing molecular contamination. Small amounts of molecular contamination could be tolerated, but were evaluated on a case-by-case basis and were dependent on location within the payload bay.

Based on the hardware cleanliness requirements, for both the First and Second Servicing Mission a new payload bay liner was cleaned to visibly clean highly sensitive (VCHS), per Johnson Space Center Document Number SNC-0005C, with an IPA/DI water mixture. During the Orbiter servicing in the Orbiter Processing Facility (OPF), the payload bay liner and thermal blankets including bilge area and wire trays were vacuumed every three days. Both the Goddard Space Flight Center and Kennedy Space Center contamination teams were success orientated, and as such, cleaned the payload bay to VCHS at the Pad Payload Changeout Room (PCR). Vertical cleaning at the Pad provided both the best access to all levels, but also provided a top down cleaning approach so that any particles cleaned from the level above, but not captured, would fall to a level which would be subsequently cleaned. Again, the thermal blankets were verified to have no significant fluorescing molecular contamination.

Cleanroom Protocol

The biggest contamination threat to the servicing carriers is the personnel working on or around them. To control this threat, the servicing carriers spend the majority of their time in a Class 10,000 (M 5.5) cleanroom. The cleanroom protocol, detailed in Reference 1, was derived from the hardware requirements, contamination control practices, and data from previous missions. Personnel constraints, cleanroom operating procedures, and site management issues are addressed for each facility in which the servicing mission hardware is assembled, integrated or tested. Activities, which have the potential to contaminate the hardware, were identified and controlled by procedure. These activities include crew familiarizations, alignment and envelopment measurements with the High Fidelity Mechanical Simulator and scientific instrument to SIPE fit checks and integration.

Launch site integration activities are also a challenge to maintaining the servicing carriers contamination levels. Because of their size, the servicing carriers must be integrated in Class 100,000 (M 6.5) facilities. However, the Class 10,000 (M 5.5) cleanroom protocols are used which typically results in a significantly lower operating level – Class 10,000 to Class 20,000 during typical integration activities. During the scientific instrument insertion into the SIPE, the cleanroom is run as a Class 10,000 (M 5.5) cleanroom with strict personnel limits (5). For both the First and Second Servicing Missions, these cleanroom protocols have resulted in hardware contamination levels significantly below the required limit.

POST-MISSION RESULTS

The post-mission surface cleanliness results are similar for both SM1 and SM2. These levels were measured while the carriers were in the payload bay at the Orbiter Processing Facility within hours of the payload bay door opening. For both SM1 and SM2, the particle levels ranged from Level 200 to Level 2000, per MIL-STD 1246. Those samples, which measured Level 2000, typically included clothing fibers. Two swab samples were taken from each carrier, one along the centerline and one from either the starboard or port sides of the carrier depending on personnel access. These samples measured less than 1.0 mg/m^2 . As the carriers were nominally 2.0 mg/m^2 just prior to launch and no suspicious species were identified, it was concluded that neither the telescope nor the Orbiter had contaminated the carriers.

It should be noted that after the Second Servicing Mission, prior to the payload bay door opening, work was performed on the Orbiter Thermal Protection System located on the payload bay doors. When the carriers were inspected, debris was found on the carriers along the centerline of the Orbiter. The debris was later identified through chemical analyses to be RTV 560, the adhesive used to bond the Thermal Protection System to the Orbiter. The payload bay doors do not form a tight seal and the RTV fell into the payload bay and onto the carriers while the Thermal Protection System work was performed. The cleanliness levels above do not include this debris in the particle level results.

CONCLUSION

A contamination control program has been developed for multi-mission flight hardware, which must meet stringent contamination requirements. The HST servicing carriers are integral to the HST servicing missions, but cannot be a potential contamination source to the telescope during EVA activities. Post-mission results from two servicing missions indicate that the servicing carriers do not contaminate the telescope and conversely, the HST and the Orbiter do not contaminate the servicing carriers. The main points of the HST servicing carrier contamination control program that are applicable to any multi-mission hardware are listed below.

1. Store, integrate, and test multi-mission hardware in stringently controlled environments, preferably a cleanroom. When not in a cleanroom, double bag hardware with approved bagging material.
2. Control the type and amount of all added materials to the multi-mission hardware so that outgassing limits are not violated. Verify, by test, that the batch of material used will not be a significant contamination source.
3. Certify outgassing levels of added (new) hardware at the sub-assembly level prior to integration onto the multi-mission hardware.
4. Maintain surface cleanliness levels during storage or low work periods. Periodic cleaning is required for multi-mission hardware that is not bagged.

ACKNOWLEDGEMENTS

The authors would like to thank the many people whose collaborative effort ensures the HST Servicing Mission successes. The NSI Contamination Control Group who maintains the hardware cleanliness levels: Wayne Geer, John Di Bartolo, Leon Bailey, Jeff Mobley, Joe Hammerbacher, Scott Lange, Joe Colony, and Barry. Greenberg. The NASA team who verifies all our surface levels: Alex Montoya, Mary Ayers-Treusdell, Doris Jallice, Neil Walter (Unisys), John Scialdone, Ben Reed (Unisys), and Fred Gross (Unisys). The modeling team who determines our cleanliness requirements: Shaun Thomson (NASA), Glenn Rosecrans (SA), Aleck Lee (LMMS), Mike Fong (LMMS), and Cliff Gee (LMMS). The Orbiter contamination team: Sally Hill (USA), Chris Webber (USA), Dave Baska (Boeing), Wayne Batungbacal (USA), Chuck Calin (USA), Jean Abernathy (NASA), Martin Mc Clellan (USA), Carol Nguyen (Boeing), and Gene Borson (SA). The purge team who provided a continuous purge to the carriers for five launch site facilities: Craig Chivatero (LMMS), Schonda Rodriguez (NASA), Max Swanko (NSI), and Larry Dell (LMTO).

REFERENCES

1. R.J. Hedgeland, P.A. Hansen, and D.W. Hughes, "An Integrated Approach for Contamination Control and Verification for the Hubble Space Telescope First Servicing Mission", SPIE 2216: 10-21, July 1994.
2. P.A. Hansen, et. al., "Hubble Space Telescope Second Servicing Mission Contamination Control Program", SPIE 2864: 27-35, August 1996.
3. P.A. Hansen and C.R. Maag, "Contamination Control Program for the Hubble Space Telescope Second Servicing Mission", Proceedings of the 7th International Symposium on 'Materials in Space Environment', SP-399: 135-142, June 1997.
4. P.A. Hansen, R.J. Hedgeland, C.R. Maag, and C.H. Seaman, "Results of STS-51 Orbiter Crew Compartment Contamination Generation and EVA Payload Bay Transfer Experiment", SPIE 2261: 2-9, July 1994.
5. D.W. Hughes, R.J. Hedgeland, W.C. Geer, and B.N. Greenberg, "Maintaining a Class M 5.5 Environment in a Class M 6.5 Cleanroom", SPIE 2261: 46-57, July 1994.

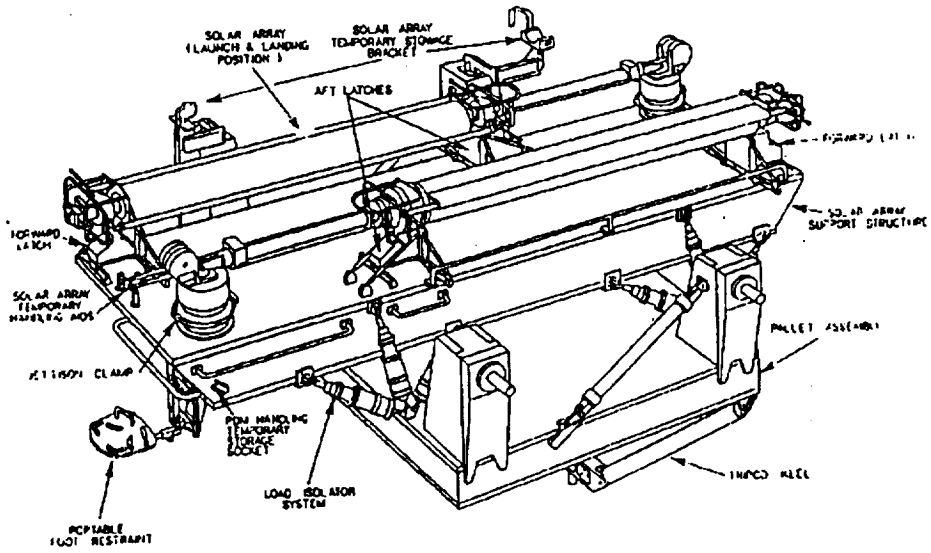
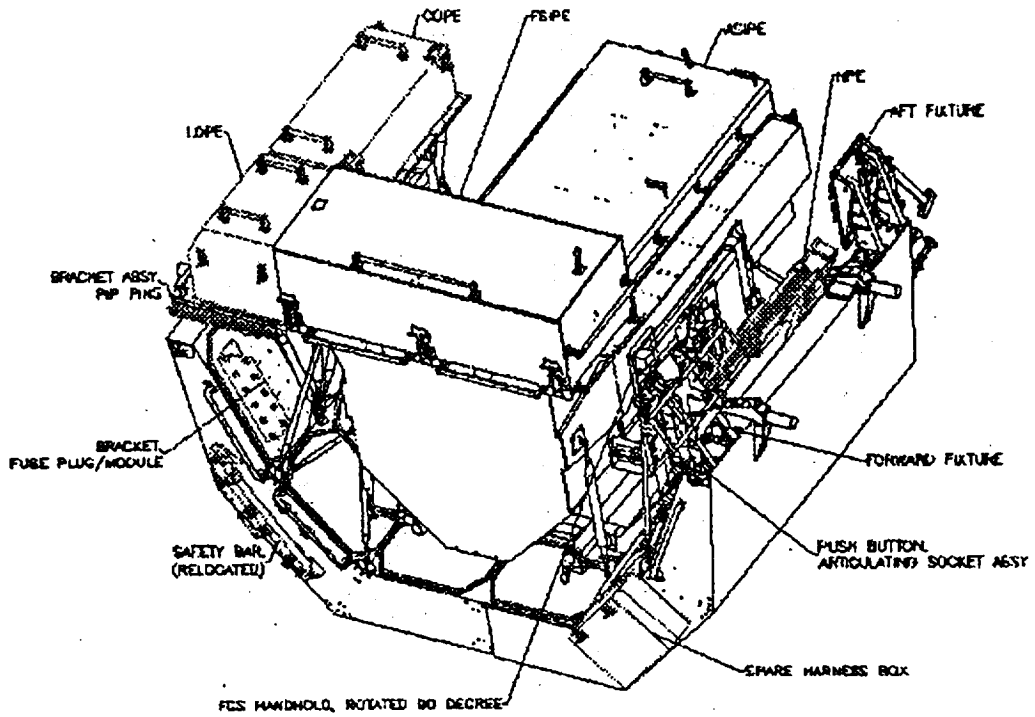

Figure 1. Solar Array Carrier



COLOR CODE INDICATES FLIGHT CONFIGURATION, DIFFERENT FROM CURRENT CONFIGURATION

Figure 2. Orbital Replacement Unit Carrier

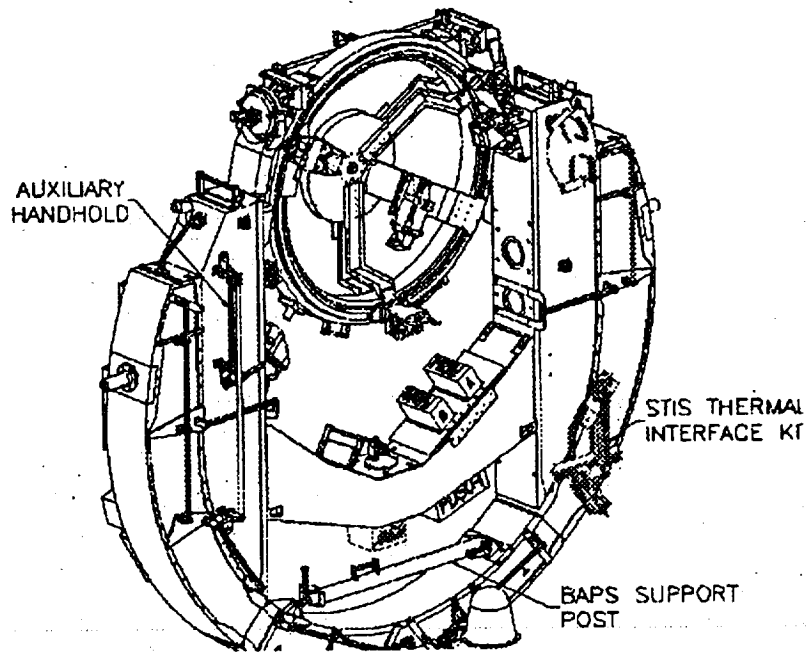

Figure 3. Flight Support System

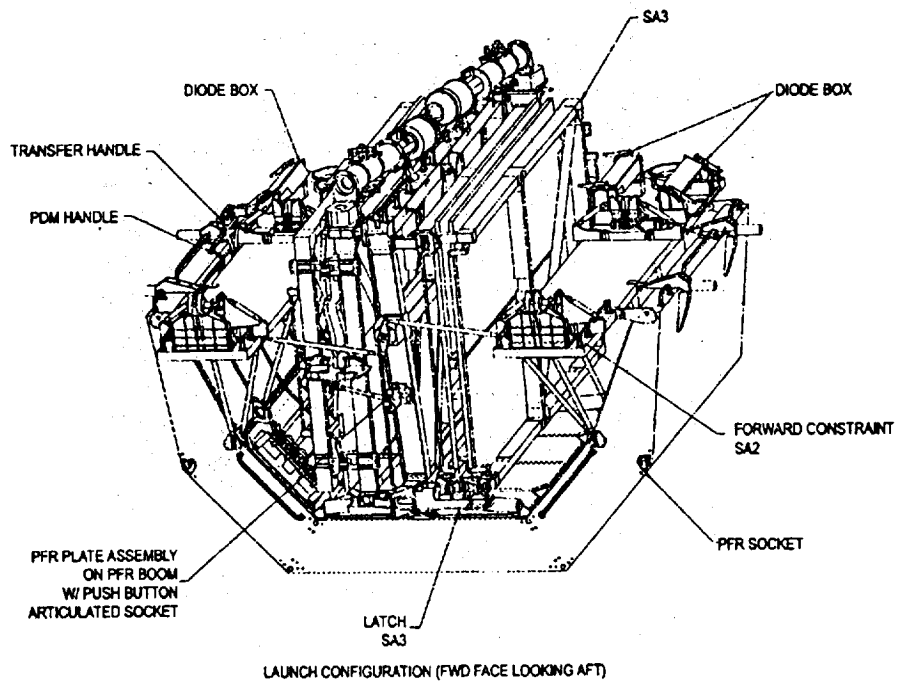

Figure 4. Rigid Array Carrier

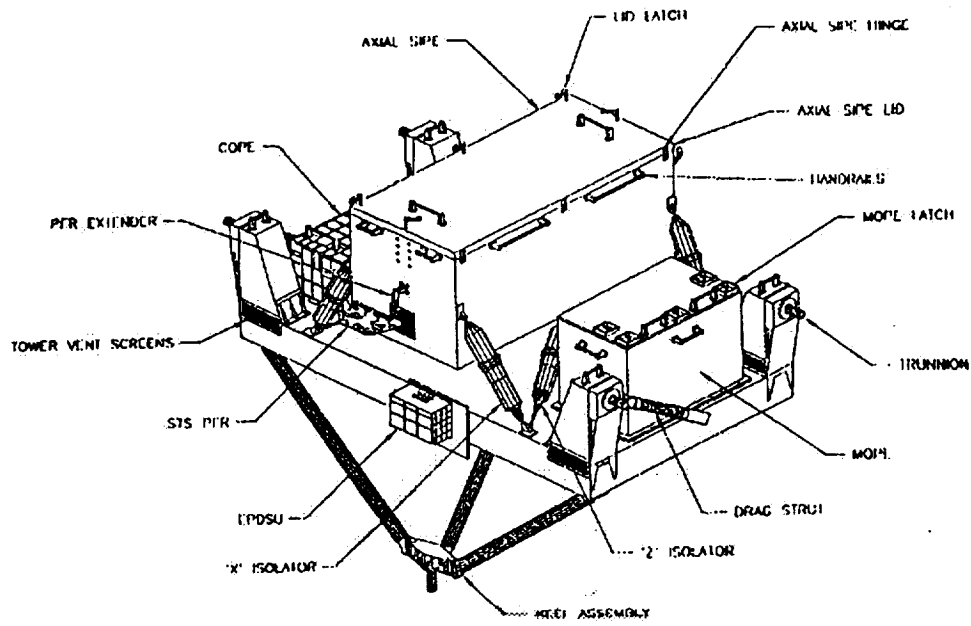

Figure 5. Second Axial Carrier

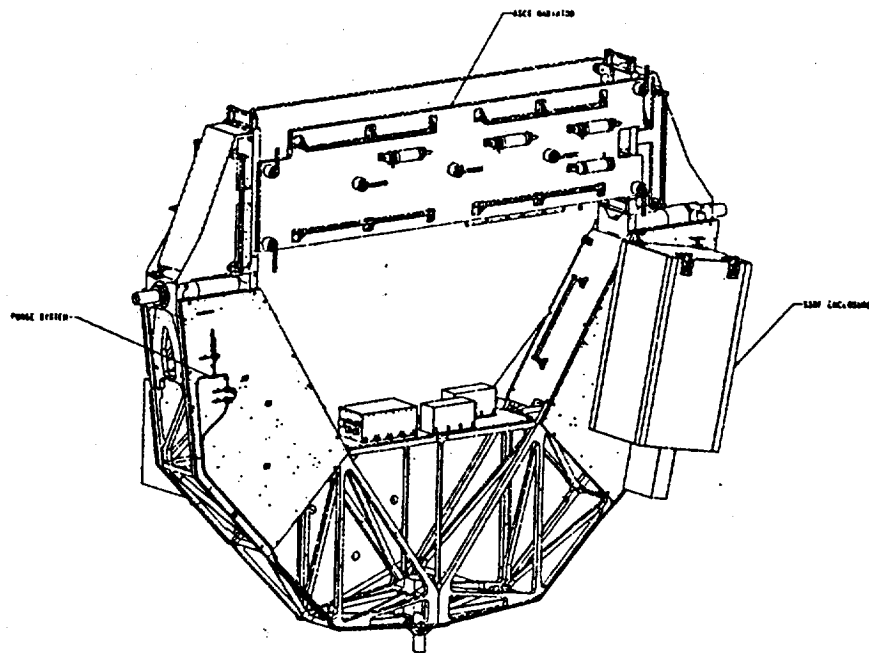

Figure 6. Multi-Use Lightweight Explorer

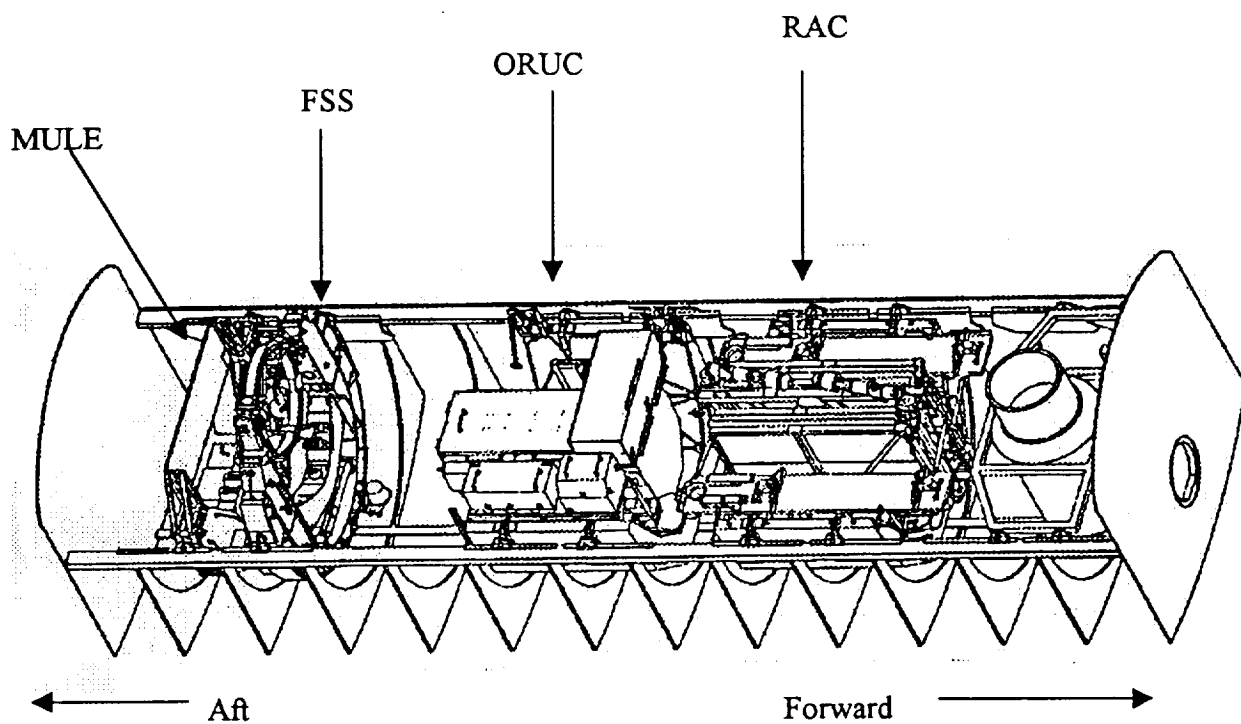

Figure 7. The HST SM3 Carrier Configuration

The servicing carriers are shown integrated with the Orbiter. From the Aft (tail) forward are the MULE, FSS, ORUC and RAC. The Orbiter external airlock is shown forward of the RAC.

PUBLIC DOMAIN DECLARATION

CAUTION: Export of technical data (information) with respect to the design, development, production, manufacture, assembly, operation, repair, testing, maintenance or modification of defense articles, i.e. all space flight hardware, ground tracking systems, launch vehicles to include sounding rockets and meteorological rockets, radiation hardened hardware and associated hardware and engineering units for listed items are controlled by the State Department, International Traffic in Arms Regulations (ITAR). Export of technical data(information) with respect to ground based sensors, detectors, National Security and Missile Technology items are controlled by the U.S. Commerce Department. Please contact the GSFC Export Control office if your export applies to the above or for further clarification of the U.S. State Department (ITAR) and the U.S. Department of Commerce Regulations. (Failure to comply with the ITAR regulations and/or the Commerce Department regulations may subject one to fines of up to \$1 million dollars and/or up to 10 years imprisonment per violation)

If your technical data does not apply with the above criteria, please select the numbered category below which best supports your declaration:

1. Public Domain - information which is published and which is generally accessible or available to the public
 - a. Through sales at news stands and bookstores;
 - b. Through subscriptions which are available without restriction to any individual who desires to obtain or purchase the published information;
 - c. Through second class mailing privileges granted by the U.S. government
 - d. At libraries open to the public or from which the public can obtain documents;
 - e. Through patents available at any patent office
 - f. Through unlimited distribution at a conference, meeting, seminar, trade show or exhibition, generally accessible to the public, in the United States,
 - g. Through fundamental research in science and engineering at accredited institutions of higher learning in the U.S. where the resulting information is ordinarily published and shared broadly in the scientific community. Fundamental research is defined to mean basic and applied research in science and engineering where the resulting information is ordinarily published and shared broadly within the scientific community, as distinguished from research the results of which are restricted for proprietary reasons or specific U.S. Government access and dissemination controls. University research will not be considered fundamental research if:
 - (1) The University or its researchers accept other restrictions on publication of scientific and technical information resulting from the project or activity, or

- (2) The research is funded by the U.S. Government and specific access and dissemination controls protecting information resulting from the research are applicable.
- h. Through public release (i.e., unlimited distribution in any form (e.g. not necessarily in published form) after approval by the cognizant U.S. government department and agency
 - i. Publicly Available Technology and Software- that technology and software that are already published or will be published; arise during, or result from fundamental research; are educational; or are included in certain patent applications (see 15 CFR 734)

Patricia A. Hansen
Signature

8/14/98
Date

1f
Category No.