

NASA Technical Memorandum 104 745

# **JSC Director's Discretionary Fund Program**

1991 Annual Report

Compiled by  
*New Initiatives Office*  
*Lyndon B. Johnson Space Center*  
*Houston, Texas*

November 1991

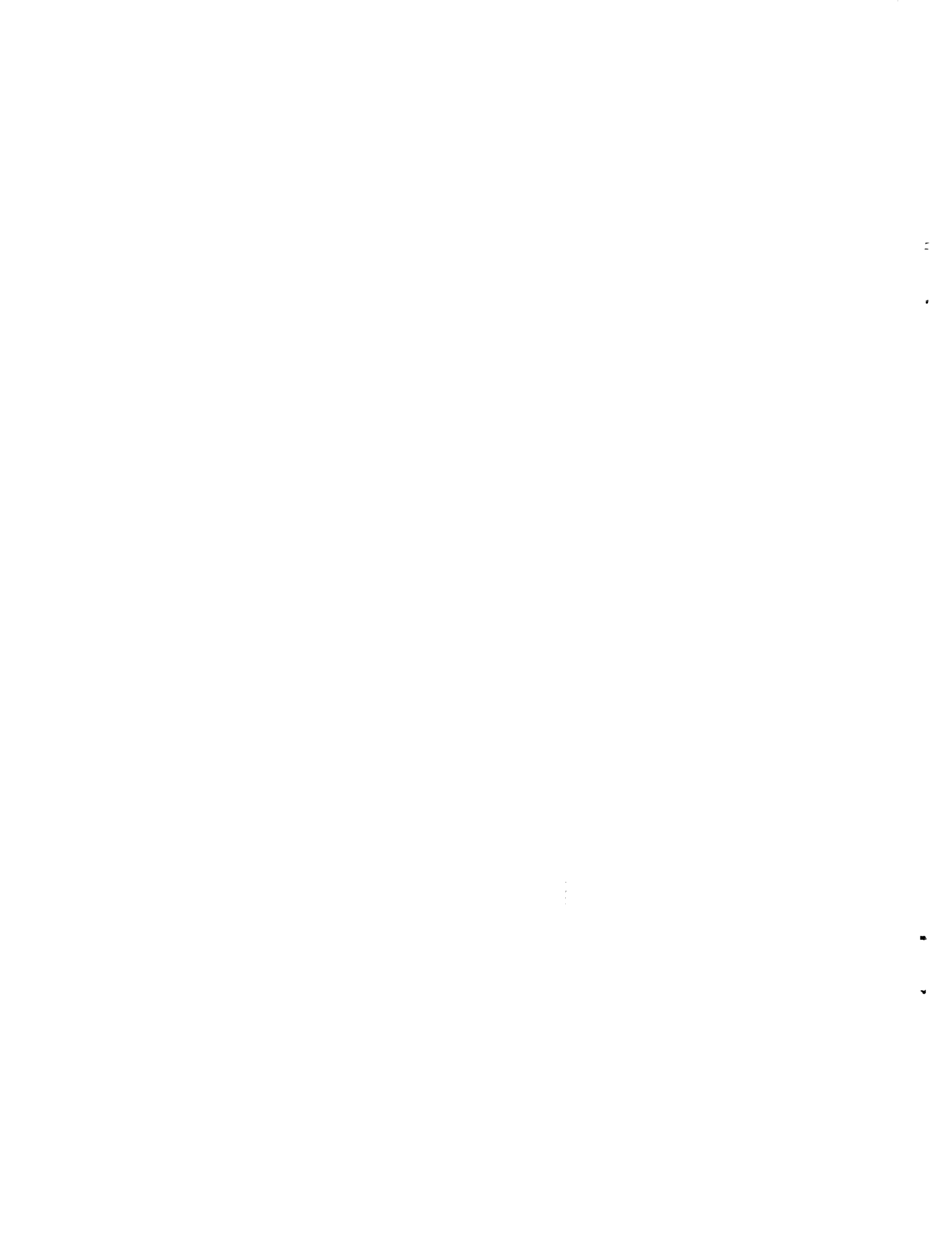

---

## Preface

---

---

The ability of the JSC Director's Discretionary Fund (DDF) to effectively support research projects at the Johnson Space Center (JSC) was enhanced by the early distribution of project funding from NASA Headquarters. Those research projects are described in this report, which will demonstrate the benefits gained from building a bridge between research and engineering. In addition, assigning individual projects to teams of both young and experienced engineers provided an opportunity for motivation and training. The \$1,540,00 funding for FY91 was distributed among 29 projects representing participation across the Center directorates.

Selection of proposed projects for funding was generally based on the following criteria: an emphasis on in-house work; a project span of 3 years or less – at a nominal funding level of \$50k per year (provided funding is not available from other sources) – and on an early identifiable product with the potential for a new start with specific funding support. Research benefits for Space Exploration Initiative (SEI)-related projects were channeled toward the SEI Program. The initiation of a project on *in situ* resource utilization supplemented the ongoing projects of regenerative life support, human spacecraft design, and lunar surface habitat. By taking these steps, JSC has been able to maintain a viable program of life sciences, space sciences, and engineering research in the absence of exploration program resources.

The following is a brief status report on selected projects with potential for broader applications.

- The investigation of the potential use of *in situ* materials on the Moon was initiated by experimenting with the modified sulfate process to obtain lunar oxygen, setting up a hydrogen reduction laboratory, establishing a sintering laboratory, and verifying the compositions and structures of simulated lunar glass.
- The Human Space Transportation Project provided requirements definition, analyses and trade studies, conceptual designs, and systems engineering and integration activities for space transportation systems that will take humans to the Moon and to Mars, and return them safely to Earth.
- The Regenerative Life Support Systems Test Bed Project completed buildup and checkout testing of the Variable Pressure Growth Chamber. The plant growth systems were verified during four, 30-day lettuce crop growth tests.
- The design and construction of the Hybrid Regenerative Water Recovery System and initial component testing was completed. Waste water was collected from shower, hand wash, laundry, and urinal sources and processed through a two-stage, aerobic trickling filter biological reactor integrated with two physiochemical processes – reverse osmosis and photocatalytic oxidation.
- The project to eliminate body degradation at zero gravity showed promising results. Work is under way to develop a protocol for effectively restoring plasma volume by exposing the

crewmember to lower body pressure, thereby increasing the orthostatic tolerance. This will better facilitate reentry and landing after emerging from a zero gravity state. By developing the optimum protocol which could restore plasma volume and orthostatic responses with a minimum of time and discomfort, crew risk during and after reentry may be minimized. We anticipate that the 2-hour, sinusoidal lower-body negative pressure treatment may prove at least as effective as the current 4-hour continuous pressure treatment.

- The first KC-135 flight series using the Phillips Laboratory/Foster-Miller experiment package was conducted to investigate two-phase (gas-liquid) flow regimes and pressure drops in pipe components under variable gravity conditions.
- Tests demonstrated that grid bumpers fragment the hypervelocity meteoroids or debris particles upon impact with the efficiency of continuous shields, as had been postulated. This change to the Space Station Freedom shields will be proposed.
- Preliminary studies have provided an experimental foundation for study of the effect of cytokines on B cell sensitivity to radiation. The research may provide ways to protect the astronauts on long space flights.
- Locating flaws in structural materials using holography has been validated. Application of these techniques will enhance the quality control in NASA-wide programs.
- NASA, as a whole, benefits from the activities and functions of the team at the White Sands Test Facility. This team's effective use of DDF funds extends their ability to respond to Agency needs. The White Sands facilities and individuals provide a unique capability in materials, testing, and system interactions that could be exploited with additional resources.

For additional information on the projects listed in this report, contact the individual investigators or contact Lyle Jenkins at (713) 283-5405.

  
William J. Huffstetler  
Manager, New Initiatives Office

---

# Contents

---

Project	Page
Regenerative Life Support Systems (RLSS) Test Bed Project <i>Donald L. Henninger, Ph.D.</i> .....	1
Lunar Surface Systems <i>Nathan Moore</i> .....	3
In-Situ Resource Utilization <i>David S. McKay, Ph.D. and Thomas A. Sullivan, Ph.D.</i> .....	5
Human Space Transportation (HST) Project <i>Katherine R. Daves</i> .....	9
Threshold Low-Cost Intermediate Technology Experiment (T-LITE) Body Mass Measurement Device <i>Edgar Castro and Kelley Cyr</i> .....	12
High-Temperature Superconductor (HTS) Antenna Investigation <i>Phong H. Ngo</i> .....	15
Orbital Debris Radar Ground Studies <i>G. D. Arndt and P. Fink</i> .....	17
Two-Phase Flow Characterization for Fluid Components and Variable Gravity Conditions <i>John Dzenitis and Katy Miller</i> .....	19
Hybrid Regenerative Water Recovery System (HRWRS) <i>Eugene H. Winkler</i> .....	22
Programmable Remapper Interface Upgrade <i>Timothy E. Fisher</i> .....	24
Thermal Analyzer for Planetary Soils (TAPS) <i>James L. Gooding, Ph.D.</i> .....	26
Backscatter Mossbauer Spectrometer (BaMS) for Analysis of Planetary Surface Materials <i>Richard V. Morris, Ph.D.</i> .....	30
Comparison of Continuous and Discontinuous Collisional Shields <i>Friedrich Hörz</i> .....	33
Lymphocyte Activation in Simulated Microgravity and Hypergravity <i>Clarence F. Sams, Ph.D.</i> .....	36

Project	Page
Evaluation of New Body Composition Techniques in Variable G's <i>Steven F. Siconolfi, Ph.D.</i> .....	39
Plasma Volume and Orthostatic Tolerance <i>Suzanne M. Fortney, Ph.D.</i> .....	42
Determining Human Energy Utilization During Space Flight Using Doubly Labeled Water <i>Helen W. Lane, Ph.D., Everett K. Gibson, Ph.D., and Randall J. Gretebeck, Ph.D.</i> .....	45
Search Coil System to Record Eye Movements for Studies of Eye, Head, Hand Coordination <i>Jacob J. Bloomberg, Ph.D.</i> .....	48
Solid-Phase Enzyme Partitioning for Liquid Waste Recycling <i>Glenn Spaulding, M.D.</i> .....	51
B Cell Radiosensitivity and Protection by Cytokines <i>Peggy Whitson, Ph.D.</i> .....	52
Adaptive Control of a Robot Arm Using an Artificial Neural Net With Stereo Vision Input <i>Timothy F. Cleghorn, Ph.D.</i> .....	56
Distributed Artificial Intelligence-Based Schedule Assessment for Space Shuttle Flight Software Production <i>John F. Muratore</i> .....	58
Virtual Environments for Training <i>Robert T. Savely</i> .....	60
Optical Analysis Systems <i>John Mulholland</i> .....	62
Diluent Gas Studies in High-Pressure Oxygen Systems <i>Radel Bunker</i> .....	64
Development of Alloys with Improved Burn-Resistance <i>Joel Stoltzfus</i> .....	67
Evaluation of Pressurized Vessels Subject to Hypervelocity Particle Impact <i>Michelle A. Rucker</i> .....	70
Long-Term Material/Fuel Interactions Predicted by Microcalorimetry <i>Radel Bunker</i> .....	72
Real-Time Multipurpose Monitor for Assessing the Integrity of Confined Atmospheres <i>Harold D. Beeson</i> .....	75

## Tables

Table		Page
1	HST Task Update – 10/91 .....	11
2	Threshold Pressure for Combustion for Some Elements .....	68

## Figures

Figure		Page
1	Mature lettuce crop in variable pressure growth chamber .....	2
2	Oxygen release from iron oxide in lunar simulant glass as a function of temperature (1 hour) .....	7
3	Oxygen release from iron oxide in lunar simulant glass as a function of time (1000 °C) .....	7
4	Back-scattered electron image of sintered lunar simulant basalt (frame width = 500 mm) .....	7
5	Compressive strength of sintered lunar simulant basalt as a function of sintering temperature (1 hour) .....	7
6	The BMMD in use on the Orbiter middeck. The BMMD may use the same fittings used to attach the crew seats to the floor during ascent and entry. If additional headroom is necessary, the BMMD could be placed in the seat location directly under the middeck access opening .....	13
7	HTS antenna .....	16
8	Front-end RF electronics for debris tracking antenna .....	18
9	Debris radar tracking receiver .....	18
10	USAF Phillips Laboratory/Foster-Miller Test Package aboard the KC-135 .....	20
11	HRWRS schematic .....	22
12	Functional block diagram for TAPS Mark-1 sensor test bed. Six different signals comprise output from sample (S <sub>x</sub> , S <sub>y</sub> ) and reference (R <sub>x</sub> , R <sub>y</sub> ) sensors that measure temperature (T), water-vapor concentration (W), and differential calorimetric power (P) .....	27

Figure	Page	
13	Representative test data for synthetic gypsum acquired with the TAPS Mark-1 sensor test bed. The various signals correspond to those identified in figure 12.....	28
14	Mossbauer spectrum of metallic iron foil obtained with the miniature velocity transducer operating in sinusoidal mode. Transducer specifications: size = 1.5 × 3.5 cm, weight = 19 g; power < 1mW.....	31
15	Representative grid penetrations at three different impact velocities employing custom-made grids manufactured from welding rods that have identical center-to-center mesh distances ( $M = D_p = .13$ in.), yet two different scaled thicknesses $D_p/T = 2$ and $5$ . Note that target damage increases with velocity; also, total displaced target mass decreases with increasing $D_p/T$ (e.g., compare experiments #803 and #806).....	34
16	Rear-witness plates simulating flight systems that are damaged by debris particles generated during the penetration of single membranes and multiple grids (all at 6 km/s, using .13 in. projectiles). Note the degree of damage as a function of absolute areal shield mass ( $g/cm^2$ ) and that the grid bumper vastly outperforms the continuous shield at equivalent mass (e.g., #812 versus #826).....	35
17	Activation of suspended lymphocytes. Peripheral lymphocytes were activated with the surface active mitogen, PHA (fig. 17a), or the phorbol ester, PMA (fig. 17b) while in suspension on a hematology rocker. The expression of the CD69 activation marker is along the vertical axis, and the expression of the T-cell marker, leu 4, is along the horizontal axis. The activated T cells are those expressing both the CD69 and leu 4 markers.....	37
18	Comparison of bioelectrical resistance estimates of total body water with true ( $O-18$ labeled water) measures in 14 subjects. Estimates of total body water were made with regression equations from Lukaski, et al. [O] (ref. 3, Kushner & Schoeller [□] (ref. 4), and from the new [▲] 3rd order polynomial model.....	40
19	Comparison of limb volumes (simulated) to computer limb volumes using compliance volumetry. The mean error rate for these measures was less than 0.15 percent.....	40
20	Comparison of the change in limb volume to the computed change in limb volume using compliance volumetry. The mean error rate for these measures was less than 1 percent.....	40
21	Comparison of the limb <i>blood</i> flow (simulated) to the computed limb <i>blood</i> flow using compliance volumetry. The mean error rate for these measures was less than 1 percent.....	40



Figure	Page
22	Deuterium elimination rate, energy/GI men's bed rest study..... 46
23	Oxygen-18 elimination rate, women's study – subject 1 ..... 46
24	2-propanol to acetone..... 51
25	Effect of sig expression on CESS radiosensitivity..... 54
26	B cell activating agents..... 54
27	Bebe Ly of the Information Systems Directorate's Software Technology Branch demonstrates the VPL research equipment ..... 61
28	Hologram of flat structure showing four evident cracks..... 63
29	Phase map/wire-frame plot of cracked structure..... 63
30	Schematic of test chamber..... 65
31	Minimum diluent concentration (MDC) in diluent/oxygen mixtures required for Teflon PTFE self-extinguishment ..... 66
32	MDC in diluent/oxygen mixtures required for KEL-F 81 self-extinguishment..... 66
33	MDC in diluent/oxygen mixtures required for Viton self-extinguishment..... 66
34	Vacuum arc-melting furnace for making new alloys ..... 68
35	Swaging machine for forming test specimens..... 68
36	Example of an alloy that has been cast and partially swaged ..... 69
37	Bench-scale apparatus used to verify concept of real-time mass spectral analysis ..... 76



---

---

**TITLE OF INVESTIGATION:** Regenerative Life Support Systems (RLSS)  
Test Bed Project

**PROJECT MANAGER:** Donald L. Henninger, Ph.D./EC3/(713) 483-5034

<b>FUNDING:</b>	<b>FY89</b>	<b>FY90</b>	<b>FY91</b>	<b>FY92</b>	<b>FY93</b>
In-house:	\$0	\$300k	\$300k	\$300k	\$500k
Contractors:	0	0	0	0	0
Grants:	0	0	0	0	0
Total funds:	\$0	\$300k	\$300k	\$300k	\$500k

---

---

## **OBJECTIVE AND APPROACH**

The objective of the RLSS Test Bed Project is to use higher plants grown in a closed, controlled environment in conjunction with physicochemically based life support subsystems to provide an integrated biological/physicochemical life support system test bed for evaluation of various RLSS approaches.

The biological component of the test bed will be fully automated to grow candidate crops from seed to harvest without the need for human intervention. Additionally, one of the test bed's two growth chambers will be operable at both ambient and reduced atmospheric pressures to more closely duplicate candidate lunar and martian habitat environments. The test bed will be complemented by incorporation of a high-fidelity human metabolic simulator which will supply variable metabolic loads to the system to simulate the presence of a crew. Major objectives of the test bed include quantification of life support capabilities of higher plants (i.e., oxygen production, carbon dioxide uptake, and water conditioning via transpiration), determination of interactions between the biological and physicochemical life support system components, and

investigation of integrated control system approaches for providing variable life support capabilities on demand. Data from the RLSS Test Bed Project will be used to define requirements for the planned Human-Rated RLSS Test Facility to be developed at the Johnson Space Center.

## **FY91 ACCOMPLISHMENTS**

The RLSS Test Bed Project achieved several key accomplishments during FY91, including completion of buildup and checkout testing of the variable pressure growth chamber (VPGC) and verification of its plant growth systems during a successful 30-day lettuce crop growth test (refs. 1 and 2). Three subsequent lettuce crops were grown during FY91 to gather baseline characterizations of the crops' life support capabilities and to obtain data on systems interactions to support the VPGC systems modelling effort. Figure 1 shows a mature lettuce crop grown within the VPGC which is undergoing harvesting operations. In addition to the VPGC buildup and testing activities, the ambient pressure growth chamber (APGC) was concurrently

Figure 1.— Mature lettuce crop in variable pressure growth chamber.



undergoing design, equipment and materials procurement, and buildup of subsystems. Other key activities performed in FY91 include supporting off-line plant growth experiments, biomass production analyses, and prototype hardware evaluations in the RLSS Laboratory.

### PLANNED FUTURE WORK

Anticipated FY92 accomplishments include completing buildup and performing functional testing of the APGC, retrofitting the VPGC for reconfigurable hydroponic/solid support plant growth and reduced pressure testing, conducting a verification test of the VPGC's reduced pressure operations capability, and performing integrated testing of one of the plant growth chambers with a physicochemical carbon dioxide concentration system. These various testing activities slated for FY92 will result in the production of several crops of lettuce and wheat grown hydroponically and in various solid support substrate media.

Of additional significance is the planned development, fabrication, and testing of the human metabolic simulator for integration into the test bed.

### REFERENCE DOCUMENTS

1. Henninger, D. L., et al., "Regenerative Life Support Systems (RLSS) Test Bed Performance – Characterization of Plant Performance in a Closed, Controlled Test Chamber," 21st International Conference on Environmental Systems, Society of Automotive Engineers, 1991.
2. Tri, T. O., et al., "Regenerative Life Support Systems (RLSS) Test Bed Development at NASA—Johnson Space Center," 21st International Conference on Environmental Systems," Society of Automotive Engineers, 1991.

---

---

**TITLE OF INVESTIGATION:** Lunar Surface Systems

**PROJECT MANAGER:** Nathan Moore/SP-33/(713) 483-6036  
(Projected)

<b>FUNDING:</b>	<b>FY89</b>	<b>FY90</b>	<b>FY91</b>	<b>FY92</b>	<b>FY93</b>
In-house:	100k	148k	100k	75k	tbd
Contractors:					
Grants:					
Total funds:	100k	148k	100k	75k	tbd

---

---

## **OBJECTIVE AND APPROACH**

FY91 objectives for the JSC Director's Discretionary Fund Program investigation centered around two main projects: the design and development of an initial Mars habitat and of a hyperbaric lunar airlock. The objectives for these projects were 1) to arrive at a set of design guidelines and assumptions which would serve as the framework for a conceptual design to be built around, and 2) to develop designs documented in the form of computer multimedia presentations; desktop models; and low-fidelity, full-size mockups.

The approach taken for these projects was as follows: background assumptions, design guidelines, and mission drivers were identified and documented; conceptual design options were presented and evaluated; and candidate design solutions were selected. At a specified time (near the midpoint of the project) a conceptual design solution was designated and frozen to change. The remainder of the project entailed the development and presentation of the design solution in model and mockup forms, followed by evaluations.

## **FY91 ACCOMPLISHMENTS**

In FY91, design teams were assembled with specialists from the following NASA organizations: the Man-Systems Division, the Lunar/Mars Exploration Program Office, the Medical Sciences Division, the Systems Engineering Division, and the Mission Operations Directorate. These teams met regularly to discuss and generate background information to support the two design projects.

Final designs for the habitat and the airlock were completed and documented in the form of computer hypermedia presentations. The background assumptions, design guidelines, and information about the missions which these designs support were documented in textual reports. A desktop model showing exterior and interior elements of the initial Mars habitat was fabricated. Drawings were also produced which specify a full-size mockup (to be build in FY92) of the airlock project.

## **PLANNED FUTURE WORK**

FY92 activity will continue work on the airlock project in the form of a full-scale mockup.

New starts for FY92 will include initial development of a rapid habitat prototyping tool, a lunar dust control study, and the upgrade of a partial-gravity simulator.

The rapid habitat prototyping tool will facilitate the development of habitat prototype concepts and optional configurations which will include a selection of options for crew size, mission length, system configuration, and criteria for concept evaluations.

The dust control study will focus on dust removal techniques and procedures for extravehicular activity/extravehicular mobility unit

system elements. Potential physical removal techniques include brushing/shaking, open-grate flooring, overgarment removal, protective overboots, and laminar airflow systems.

The partial gravity simulator (POGO) is a project to upgrade and enhance the Apollo partial-g simulator.

---

---

**TITLE OF INVESTIGATION:** *In-Situ* Resource Utilization

**PROJECT MANAGERS:** David S. McKay, Ph.D. and Thomas A. Sullivan, Ph.D.  
Mission Science & Technology Office/SN14/ (713) 483-5048

<b>FUNDING:</b>	<b>FY89</b>	<b>FY90</b>	<b>FY91</b>	(Projected)	<b>FY93</b>
				<b>FY92</b>	
In house:	\$0	\$0	\$150k	\$150k	\$200k
Contractors and grants:	\$0	\$0	\$0	\$0	\$0
Total funds:	\$0	\$0	\$150k	\$150k	\$200k

---

---

## **OBJECTIVE AND APPROACH**

Three separate studies have been conducted under this project. The production of oxygen from lunar regolith material is the goal of two different chemical techniques, the sulfate process and hydrogen reduction. If oxygen for propellant can be produced from local lunar resources, an enormous savings in lunar base transportation costs may result. The third project examines sintering, the bonding of solid material by melting the particle edges. "Bricks" formed from sintered regolith could be used for radiation shielding and basic construction material at a lunar outpost. Sintering is synergistic with the oxygen processes in that preheated material from either of the oxygen routes can act as a feedstock for sintered block manufacture. In addition, the chemical processes related to oxygen extraction may, in some cases, enhance sintering.

### **Sulfate Process**

This project has explored modifications to a terrestrial commercial process so as to release oxygen from ilmenite. The reactions are carried out largely in solution. Two of the three major process steps have been studied to

explore their kinetics and yields. Concept development based on this and other data suggests that an efficient process is likely and points the way to future lab studies which will be done in the coming year.

### **Hydrogen Reduction**

Direct reduction of the iron in lunar glass by hydrogen is being investigated as a method of liberating oxygen. The oxygen can be liquified and stored. The hydrogen can be recycled over and over in the process. The experimental program builds on preliminary results reported by McKay et al. (ref. 1). The objectives of this program are to define the conditions under which reduction occurs and measure the sensitivity of the process to variables including temperature, run time, hydrogen flow rate, and degree of devitrification. This process offers several important advantages, including basic simplicity and the high glass abundance at certain lunar sites.

### **Sintering**

The purpose of this study is to investigate the sintering behavior of glass and basalt of lunar composition. Experiments are designed to

determine the range of conditions under which sintering takes place and the effects of temperature, heating time, and grain size on the compressive strength and microstructure of simulated lunar bricks. An efficient process for making concrete-like lunar bricks, blocks, and other shapes may result in large transported mass (cost) savings during construction of a lunar base.

## FY91 ACCOMPLISHMENTS

### Sulfate Process

Lab work on the modified sulfate process to lunar oxygen has determined the reaction kinetics of ilmenite at various acid concentrations, and has also determined many of the decomposition temperatures of sulfates in the calcination step. Electrolysis experiments have only proceeded to the equipment setup and checkout stage. Systems engineering studies are ongoing with overall process optimization in mind. A great deal of work was completed in upgrading the laboratory, and a computer spreadsheet of three versions of the process was developed. A patent application which protects six explicit versions of this process has been submitted (ref. 2), and a paper describing the work has been written (ref. 3).

### Hydrogen Reduction

The initial work on this project included setting up a hydrogen reduction laboratory and verifying the compositions and structures of lunar glass simulants. To date, 50 reduction experiments have been conducted using an Apollo 11 soil simulant. The reduced glass was shown to have textures and mineral compositions similar to those of lunar glass beads from the Apollo samples. The kinetics of oxygen release were determined from Mossbauer spectroscopy and weight loss data. Reaction mechanisms were verified by analytical

electron microscopy. Weight losses corresponding to 60 percent of the oxygen associated with iron in the glass were achieved in 1 hour at 1100 °C (fig. 2) and in 3 hours at 1000 °C (fig. 3). A lunar oxygen plant operating at this efficiency and utilizing Apollo 17 orange glass as a feedstock could produce 29.4 kg of oxygen per ton of soil processed. This yield is 2 to 10 times greater than likely yields from the hydrogen reduction of ilmenite process. These results will be presented at Space '92 (ref. 4).

### Sintering

The FY91 effort included establishing a sintering laboratory and determining the compositions of lunar simulant glass and basalt. This year, a matrix of 59 experiments was conducted to define the conditions under which sintering occurs and its relationship to temperature, duration, and grain size. The degree of sintering was assessed by microanalysis (fig. 4) and compressive strength testing. The compressive strength of sintered basalt is strongly dependent on grain size, with the maximum strength corresponding to grain sizes in the range of lunar regolith particles. Test specimens with the strength of concrete were produced by sintering basalt at 1100 °C (fig. 5). The same process on the Moon is predicted to produce stronger material due to the nature of the lunar soil and environment. The processes of sintering and oxygen production from lunar soil are synergistic, and could be combined to produce two extremely useful products at a lunar base. Our studies, to date, have been accepted for publication (ref. 5).

## PLANNED FUTURE WORK

### Sulfate Process

More detailed lab investigations of the sulfate process will determine operating conditions



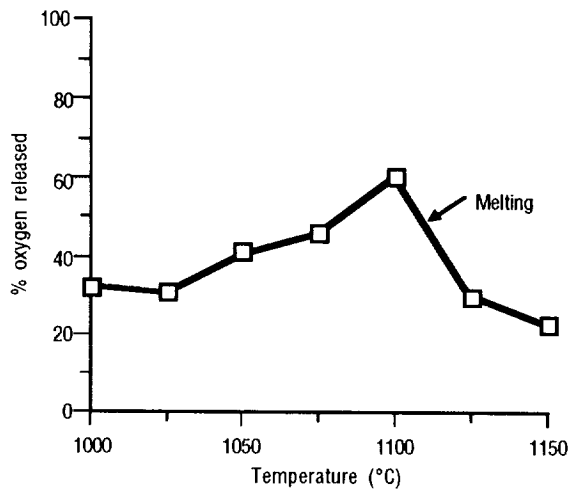

Figure 2.— Oxygen release from iron oxide in lunar simulant glass as a function of temperature (1 hour).

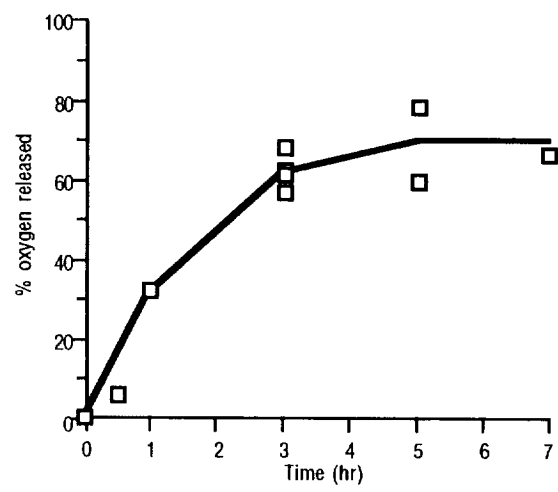

Figure 3.— Oxygen release from iron oxide in lunar simulant glass as a function of time (1000 °C).



Figure 4.— Back-scattered electron image of sintered lunar simulant basalt (frame width = 500 μm).

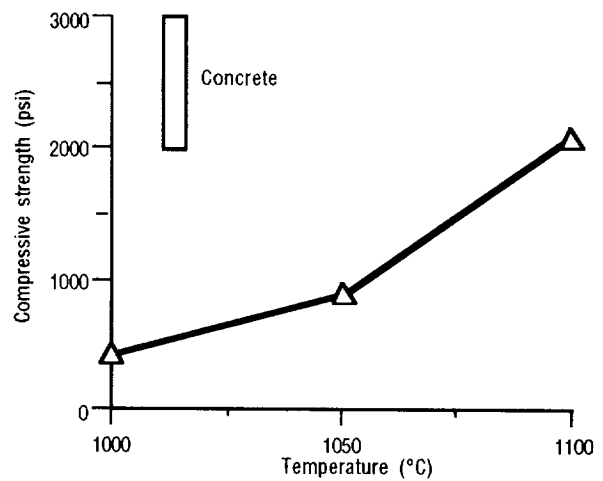

Figure 5.— Compressive strength of sintered lunar simulant basalt as a function of sintering temperature (1 hour).

for the electrolysis step as well as the fate of minerals other than ilmenite. By the end of the year it is planned that a rough, batch-type or continuous prototype system will be able to take feedstock and produce oxygen in an operable process. Work in the third year will include process optimization studies and experiments to develop the data necessary to design a prototype pilot plant and flight experiment concept.

### Hydrogen Reduction

A major goal of work in FY92 will be to determine optimum conditions and oxygen yield. This will involve experiments in both static and fluidized beds. We will further investigate the synergy between oxygen production and sintering. Our experimental setup in laboratory furnaces will be upgraded to a self-contained, PC-controlled test bed. When completed in FY93, this prototype will

serve as the design basis for a lunar demonstration plant.

### Sintering

The matrix of tests will be expanded in FY92 to demonstrate how to produce suitable bricks with the minimum expenditure of mass and energy. Experimental sintering by microwave and inductive heating will attempt to lower power requirements. Separate tests of the sintering behavior of glass and basalt will be followed by experiments combining the two in a more realistic simulation of lunar soil. A benchtop test bed will be completed in FY93 and design work will be initiated for flight hardware.

Support via Research and Technology Objectives and Plans (RTOP) funding for these proposals is expected for FY93. RTOP funds for FY91 for related work have also been received.

### REFERENCE DOCUMENTS

1. McKay, D. S.; Morris, R. V.; and Jurewicz, A. J.: "Reduction of Simulated Lunar Glass by Carbon and Hydrogen and its Implications for Lunar Base Oxygen Production," *Lunar and Planetary Science XXII*, 1991, pp. 881-882.
2. Sullivan, T. A.: Method for Producing Oxygen from Lunar Materials. U. S. patent pending.
3. Sullivan, T. A.: "A Modified Sulfate Process to Lunar Oxygen," *Space 92*, 1992, in press.
4. Allen, C. C.; McKay, D. S.; and Morris, R.V.: "Lunar Oxygen - The Reduction of Glass by Hydrogen," *Space 92*, 1992, in press.
5. Allen, C. C.; Hines, J. A.; McKay, D. S.; and Morris, R.V.: "Sintering of Lunar Glass and Basalt," *Space 92*, 1992, in press.

---

---

**TITLE OF INVESTIGATION:** Human Space Transportation (HST) Project

**PROJECT MANAGER:** Katherine R. Daues/IE3/(713) 283-5302

(Projected)

<b>FUNDING:</b>	<b>FY89</b>	<b>FY90</b>	<b>FY91</b>	<b>FY92</b>	<b>FY93</b>
In-house:	\$0	\$0	\$50k	\$0	\$0
Total funds:	\$0	\$0	\$50k	\$0	\$0

---

---

### OBJECTIVE AND APPROACH

The primary objectives of the HST Project for CY91 were to:

- Identify and resolve fundamental human space transportation mission and system issues.
- Identify technology development and precursor requirements.
- Develop and assess system and mission requirements for lunar/Mars missions, including interfaces with ground operations; Earth-to-orbit launch vehicles; and planet surface systems and nodes. This will be accomplished by conducting trade studies and analyses of major system design issues, developing conceptual designs of human space transfer and excursion vehicles, and developing a data base of parametric data for vehicle subsystems.
- Support the Marshall Space Flight Center (MSFC)/Space Exploration Initiative (SEI) Space Transportation (IA) programs.
- Ensure a Johnson Space Center (JSC) in-house level of expertise to support future human missions to the Moon and to Mars.

The HST Project was planned with the support of several JSC directorates as shown in Table 1.– HST Task Update – 10/91. A number of tasks were identified to provide

requirements definition, analyses and trade studies, conceptual designs, and systems engineering and integration activities for space transportation systems that will take humans to the Moon and to Mars and return them safely to Earth.

### FY91 ACCOMPLISHMENTS

The HST project produced significant findings that can be expected to influence the development of the space exploration program.

- *Human-Interface Requirements Study* – A human system interface requirements task initiated definition of additional research and information required to update the Man-Systems Integration Standards (MSIS) (NASA-STD-3000) in support of the exploration programs. Sections of the MSIS requiring additional inputs were identified. Distribution of a survey questionnaire assisted in identification of research projects currently under way in several key areas covered by the MSIS. A report containing recommendations for the MSIS update was provided.
- *Crew Acceleration Requirements* – This task presents preliminary recommendations for crew acceleration limits during launch and trajectory change operations, braking maneuvers, vehicle operations

- employing artificial gravity, and nominal operations.
- *Crew Radiation Requirements* – This task presents preliminary recommendations for minimizing crew radiation exposure during a Mars mission.
  - *Zero-Gravity Countermeasures* – Preliminary recommendations for microgravity countermeasures requirements for a Mars Transportation System (MTS) were drafted. Operational issues for specified human maintenance goals were identified. Preflight, inflight, and post-flight considerations were specified. Specific examples of countermeasures for various human parameters (e.g., ability to perform work, normal bodily state and functions, normal risk levels) were provided.
  - *Exploration Transportation System Crew Health Maintenance and Emergency Care* – Preliminary recommendations for crew health monitoring and emergency care requirements for an MTS were identified for opposition class and for conjunction class missions. System concepts, operational considerations, health monitoring, and environmental health needs were identified. Assessment of medical care, vehicle design, and operations needs for transfer and excursion vehicles was provided.
  - *MTS Issues Focused Effort* – The major spacecraft design issues associated with a human mission to Mars were identified and analyzed.
  - *Crew Sizing Study* – A computer program was developed to perform Mars Transfer Vehicle (MTV) Life Support System trade studies for variable crew size, mission duration, degree of closure, and hardware selection. Several issues (e.g., storage of hygiene wastewater) were brought to light from the life support subsystem (LSS) trade studies.
  - *MTS Enroute Training Study* – This task developed concepts and requirements for training while enroute to Mars; explored alternative approaches for enroute training; and identified, evaluated, and recommended a preferred approach.
  - *Crew Psychosocial Impact Study* – A psychosocial impact study for an MTV identified parameters that affect crew productivity and performance; presented potential crew responses to the MTV environment; introduced parameters for crew selection, training, and health maintenance; and provided requirements for the MTV internal design.
  - *Environmental Closed Life Support Subsystem (ECLSS) vs Regenerative Life Support Subsystem (RLSS) Trade Study* – This task collected data on physicochemical life support hardware and developed a spreadsheet program to perform LSS trade studies for variable crew size, mission duration, degree of closure, and hardware selection.
  - *Exploration Transport System (ETS) Viewing Requirements Study* – A crew viewing study provided the following: an overview of previous manned spacecraft experience; general viewing requirements from crew constraints, vehicle concerns, extravehicular activity, and natural environments perspectives; and specific vehicle/module and human viewing requirements.
  - *Lunar Excursion Vehicle (LEV) Crew Module Design & Mockup* – An integrated conceptual design for an LEV crew module was developed for a crew of four with short stay time. Design and operational ground rules and assumptions were defined. The conceptual design was rendered in a hypermedia (computer graphics) presentation and a scale model. Drawings for a full-scale mockup were initiated for production next year.

- *MTS Crew Module Internal Architectures* – Illustrations of a variety of crew module internal architectures for an MTS were developed at a conceptual design level.

## PLANNED FUTURE WORK

Activities defining spacecraft system requirements to support crew needs for the exploration program will be continued under a starworks project.

Table 1.– HST Task Update - 10/91

Task	Name	Lead	Status
1.2.1	Human-Interface Requirements	SP3	Final report due 11/25/91
1.2.2	Crew Acceleration Requirements	SD5	Draft due 12/91, final due 3/92
1.2.3	Crew Radiation Requirements	SD4	Final report due 12/91
1.2.4	Zero-Gravity Countermeasures	SD5	Draft by 10/91, final by 12/91
1.2.5	ETS Crew Health Maintenance and Emergency Care	SD2	Draft received 9/20/91; final received 10/16/91
2.1	MTS Issues-Focused Effort	ET2	Three workshops and other meetings held 1/91 to 3/91
2.2	Crew Sizing Study	DA	White paper received on 6/12/91
2.3	MTS Enroute Training Study	DA	Received 9/90 draft
2.7	Crew Psychosocial Impact Study	SD5	Received draft position paper 9/16/91; final by 12/91
2.9	ECLSS vs RLSS Trade Study	EC3	Due date is 11/25/91
2.10	ETS Viewing Requirements Study	SP3	Report due 11/8/91
3.3	LEV Crew Module Design & Mockup	SP3	Hypermedia demo is ready; drawings due 12/91; mockup due 3/92; needs \$45k more
3.1.1	MTS Crew Module Internal Architecture illustrations	IE3	Bell & Trotti support; due 1/2/92

**TITLE OF INVESTIGATION:** Threshold Low-Cost Intermediate Technology Experiment (T-LITE) Body Mass Measurement Device

**PROJECT MANAGERS:** Edgar Castro/ES221/(713) 483-8841  
Kelley Cyr/XP/(713) 283-5466

FUNDING:	FY89	FY90	FY91	(Projected)	
				FY92	FY93
In-House:	0	\$1k	\$10k	\$20k	\$30k
Contractors:	0	0	0	0	0
Grants:	0	0	0	0	0
Total funds:	0	\$1k	\$10k	\$20k	\$30k

## OBJECTIVE AND APPROACH

The T-LITE is an activity sponsored by the threshold group to provide NASA employees with the opportunity to build teamwork and leadership skills by working on a Shuttle flight experiment. The T-LITE concept calls for the extensive use of in-house resources and off-the-shelf components to keep cost down. The experiment selected for the initial T-LITE project was the Body Mass Measurement Device (BMMD) proposed by Tim Pelischek. The BMMD uses the principle of linear acceleration to determine the mass of a crewmember in a microgravity environment. One of the effects of weightlessness is a loss of body mass, and unusual weight loss or gain may be a sign of health problems. The purpose of this device is to provide the crew with a convenient means of weighing themselves while in space on long-duration missions. The target accuracy of the device is repeatability within  $\pm 1$  lb. Since the device will be used primarily to monitor weight trends, the absolute accuracy of the device is not as critical. The device will be designed to fit inside a standard Shuttle middeck locker with a goal of fitting

inside a half-size locker. The BMMD will be flown as a detailed test objective or a detailed supplementary objective and will be designed to meet the requirements associated with those payloads.

The BMMD uses Newton's second law of motion—the acceleration of an object is directly proportional to the force acting on it and inversely proportional to the mass of the object. For a mass  $m$ , force  $F$ , and acceleration  $a$ , this law can be rewritten as  $m = F/a$ . In other words, the mass of an object can be determined by applying a known force to it and measuring the resulting acceleration. In the BMMD, an elastomer tube is used to apply force to a three-sided device resembling a scissor-jack. The force is transferred through a triangulation of load cells to a plate on which the crew person may stand or kneel. The base of the device will be attached to the floor of the Orbiter middeck (fig. 6). An accelerometer attached to the device will measure the acceleration. Data from the instruments will be sent to a data analysis system where the mass will be computed. For the initial flight experiments, the BMMD data will be stored in

the payload general support computer onboard the Orbiter for later analysis. Eventually, the BMMD will include a microprocessor and a digital display. The BMMD will be capable of measuring masses between 95 and 265 lb.

The potential applications for the BMMD include: long-duration Shuttle missions, Spacelab life sciences missions, extended duration Orbiter missions, 90-day Orbiter missions, Space Station Freedom, lunar base missions, and Mars missions. Some other applications for mass measurement include weighing the payload to be carried down from the Space Station Freedom in the Orbiter and weighing samples of lunar or Mars surface material.

## FY91 ACCOMPLISHMENTS

In 1990, the team evaluated the linear acceleration method of estimating mass by conducting tests of various approaches on a precision air-bearing floor. Based on the results of the tests, two design concepts were developed. The design concept that was eventually selected operated in a different way than had previously been tested, so it was decided to build a low-fidelity mockup of the device and test it further on the air-bearing floor. The preliminary results of the mockup testing proved that the new configuration would work and that reasonable results could be expected. There were also a number of lessons learned from the testing that will be incorporated into future designs and test activities.

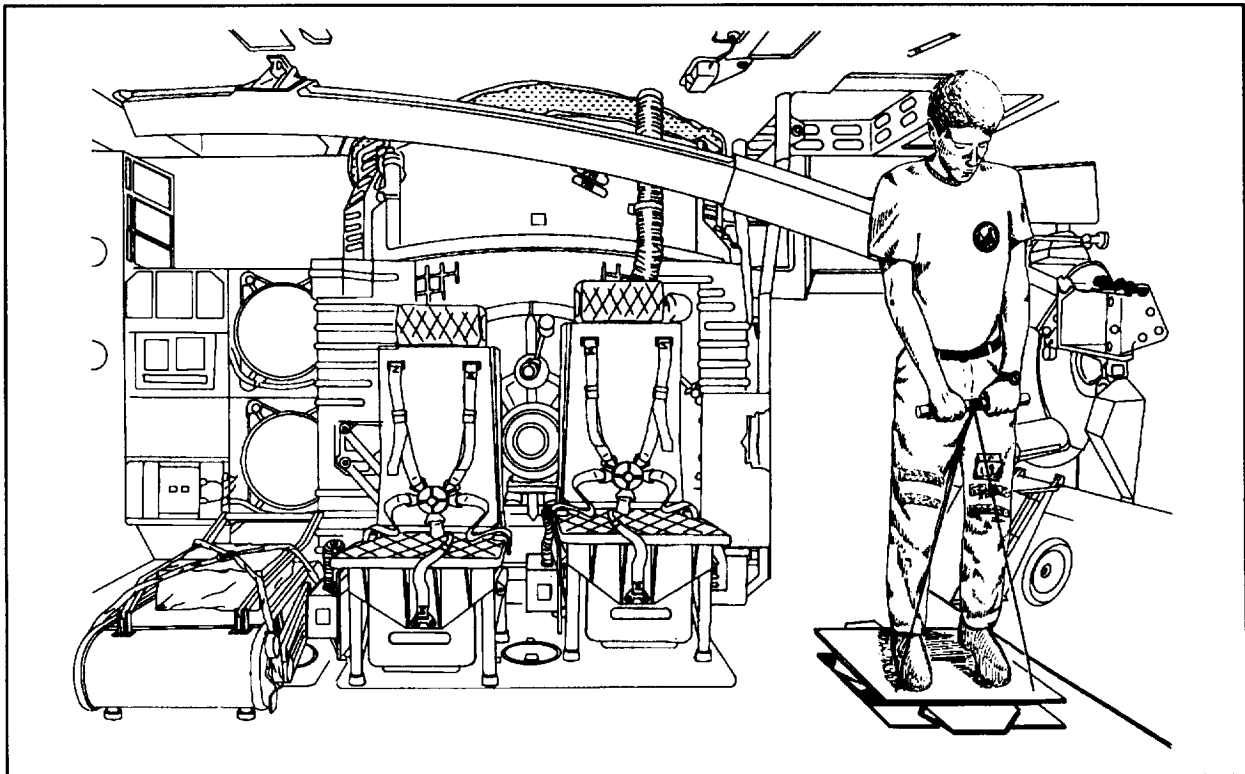

Figure 6.- The BMMD in use on the Orbiter middeck. The BMMD may use the same fittings used to attach the crew seats to the floor during ascent and entry. If additional headroom is necessary, the BMMD could be placed in the seat location directly under the middeck access opening.

While the mockup was being fabricated and tested, design work continued on a prototype which will be used for testing on the zero-gravity aircraft. The prototype was completed and installed in a test bed in Building 13. Also during FY91, the instrumentation and data acquisition systems for the flight hardware were selected and the initial set of sensors was purchased.

### **PLANNED FUTURE WORK**

The activity plan for FY92 will focus on the goal of conducting a zero-gravity test flight on the KC-135. An engineering test bed will be set up on the air-bearing floor facility in Building 13. The test bed will be used to continue testing the prototype with the aim of refining the mechanical and electronic systems and the data analysis software. Prototype testing will be conducted with both dead-weights and human subjects. Meanwhile, detailed design work will proceed on the triggering and shock absorbing mechanisms.

Once the objectives of the prototype test phase are reached, the test bed will be modified to simulate the zero-gravity test. Because of the vibration and air turbulence onboard the KC-135, it will be necessary to "free-fly" the experiment. This will involve using a large counter mass, and the motion of the counter mass will have to be taken into account in the mass calculation. The plan is to develop the necessary modifications on the test bed and simulate the free-flying mode on the air-bearing floor.

The KC-135 testing will consist of two series of two flights each. The first flight series is scheduled for the end of May 1992 (subject to availability of the aircraft). The follow-on flight test is scheduled for the end of December 1992. Assuming that the KC-135 testing is successful, the plan is to conduct an Orbiter test flight in FY93.



---

---

**TITLE OF INVESTIGATION:** High-Temperature Superconductor (HTS) Antenna Investigation

**PROJECT MANAGER:** Phong H. Ngo/EE3/(713) 483-7990

FUNDING	FY89	FY90	FY91	FY92	(Projected)	
					FY93	FY94
In-house:	\$50k	\$50k	\$50k	\$0	\$100k	\$300k
Contractors:	0	0	0	0	0	0
Grants:	60k	60k	60k	50k (?)	0	0
Total funds:	\$110k	\$110k	\$110k	\$50k	\$100k	\$300k

---

---

### OBJECTIVE AND APPROACH

The recent discovery of HTSs has drawn considerable attention towards the search for applications that will enhance the performance of communication systems. With the natural cooling abilities of space, many potential space applications have been identified (ref. 1). One such application is through the use of HTS materials in microwave and millimeter-wave feed networks for large antenna arrays. This will greatly enhance their performance and allow the replacement of the low loss, but bulky, waveguide feed structures with smaller, lighter planar structures. The objective of this investigation is to study and develop a 16-element antenna array which can be integrated into an HTS/advanced communications technology satellite (ACTS) receiver experiment as a joint Johnson Space Center/Lewis Research Center (LeRC) effort.

### FY91 ACCOMPLISHMENTS

- Completed antennae test setup (refer to fig. 7)
- Designed one 12-GHz, all-metal aperture coupled patch (ACP) antenna

- Fabricated two test fixtures for testing of ACP antennae
- Characterized five resonator circuits (three HTSs, two gold) deposited on MgO substrate
- Initiated preliminary design concepts for 1996 HTS/ACTS flight experiment

### PLANNED FUTURE WORK

- Complete fabrication and test of all metal and HTS ACP antennas
- Extend ACP antennas into 16-element array
- Integrate antenna array with receiver for 1996 flight experiment with LeRC

### REFERENCE DOCUMENTS

1. Heinson, O.V.; Bhasin, K. B.; Long, K. J.: Emerging Applications of High Temperature Superconductors for Space Communications. NASA Technical Memorandum 103629.

Figure 7.- HTS antenna.



---

---

**TITLE OF INVESTIGATION:** Orbital Debris Radar Ground Studies

**PROJECT MANAGERS:** G. D. Arndt and P. Fink/EE3/(713) 483-1438 & 483-0973

<b>FUNDING</b>	<b>FY89</b>	<b>FY90</b>	<b>FY91</b>
In-house:	\$40k	\$45k	\$40k
Contractors:	0	0	0
Grants: (University)	50k	0	0
Total funds:	\$90k	\$45k	\$40k

---

---

### **OBJECTIVE AND APPROACH**

There are two primary objectives of this study. The first objective is to define a low-cost ground demonstration radar system capable of detecting and tracking small particles simulating orbital debris. This ground system is a precursor to a possible spaceborne radar for tracking incoming orbital debris. The second objective of this study is to perform a system-level integration study with a microwave radar for ranging and an optical detection system for angle acquisition.

The approach was to first develop and test a Ku-band phased array using microstrip patch antennas as the subarrays. The antennas and array electronics (fig. 8) were completed in FY90. In FY91, a sensitive radar receiver (fig. 9) was designed to interface with the antenna; this receiver is now being constructed and should be available for testing by April 1992.

An integrated Research and Technology Objectives and Plans (RTOP) proposal covering four technical areas (microwave tracking, laser tracking, optical detection, and debris

management) was submitted to Code M for possible funding.

### **FY91 ACCOMPLISHMENTS**

- Completed control software development and digital control boards 2/91
- Design of receiver completed and fabrication underway
- Microwave tracking antenna/optical acquisition system integration study underway
- Discussions with Sandia National Laboratories regarding possible utilization of their receiver technology in this project

### **PLANNED FUTURE WORK**

- Complete receiver; integrate with antenna and test
- Complete microwave/optical system integration study

- Utilize Sandia's expertise in receiver technology
- Get RTOP proposal funded

## REFERENCE DOCUMENTS

Technical paper submitted for World Space Conference to be held in Washington, August 1992.

Figure 8.— Front-end RF electronics for debris tracking antenna.

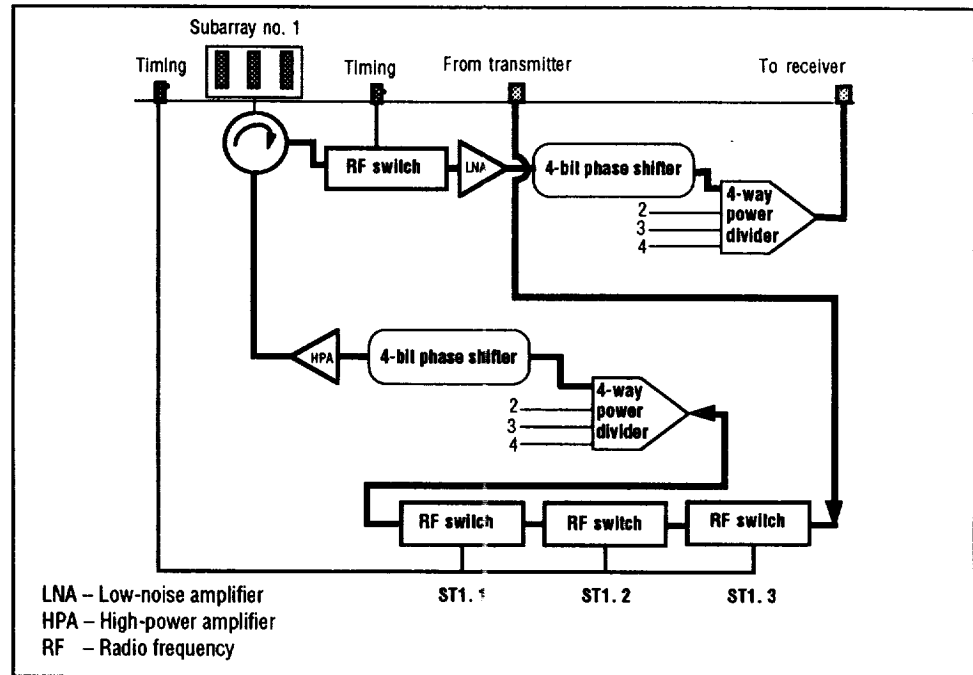
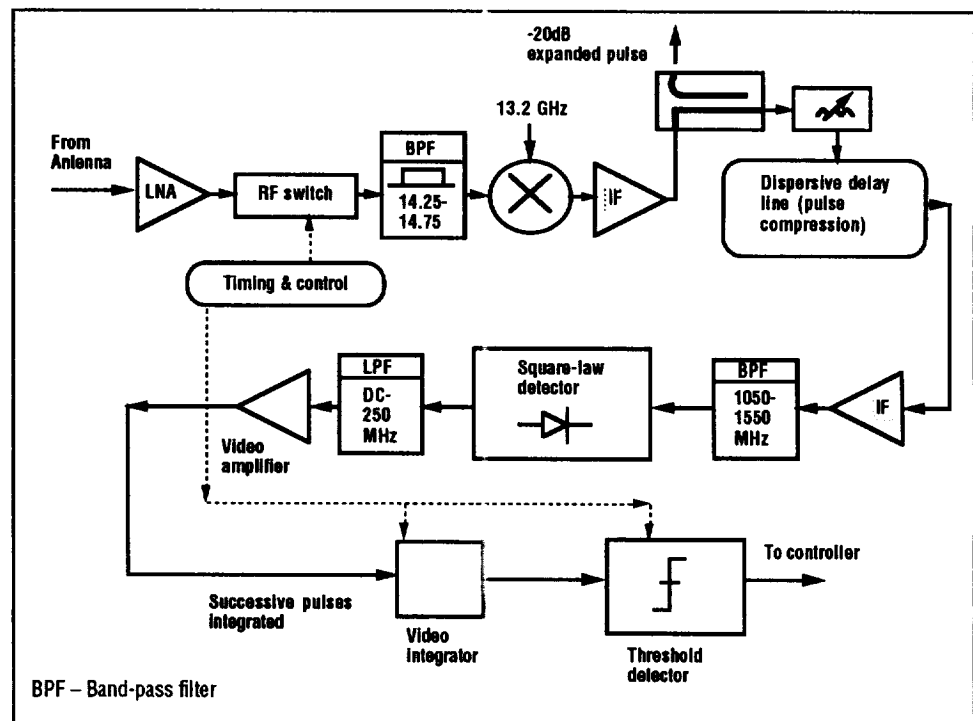

Figure 9.— Debris radar tracking receiver.



---

---

**TITLE OF INVESTIGATION:** Two-Phase Flow Characterization for Fluid Components and Variable Gravity Conditions

**PROJECT MANAGERS:** John Dzenitis/EC7/(FTS) 525-9147  
Katy Miller/EP5/(FTS) 525-4546

**FUNDING:**

JSC Director's Discretionary Fund (for variable gravity testing)

	FY89	FY90	FY91	(Projected) FY92	FY93
In-house:	\$0	\$0	\$5k	\$35k	\$0
Contractors:	0	0	0	0	0
Grants:	0	0	45k	15k	0
Total funds:	\$0	\$0	\$50k	\$50k	\$0

Space Station Fund (in support of the Space Station thermal bus)

	FY89	FY90	FY91	(Projected) FY92	FY93
In-house:	\$0	\$0	\$66k	\$30k	\$0
Contractors:	0	0	0	0	0
Grants:	0	0	54k	70k	0
Total funds:	\$0	\$0	\$120k	\$100k	\$0

---

---

**OBJECTIVE AND APPROACH**

This program was initiated in FY91 to investigate gas-liquid flow regimes and pressure drops in pipe components and variable gravity conditions. This project supports both the Space Station Freedom thermal bus design and the Space Exploration Initiative activities for low-g (e.g., Moon-g, Mars-g) fluid studies.

The JSC Director's Discretionary Fund Program is providing for the variable gravity testing to support the development of thermal control systems for Moon and Mars missions. In addition, both the Propulsion and Power Division, and the Crew and Thermal Systems Division at the NASA Johnson Space Center (JSC) are providing Space Station funding to investigate flow regimes and pressure drops expected in the Station

thermal bus and utility distribution system.

The objectives of this program include

- A study of the two-phase flow phenomena in fluid components (e.g., smooth pipes, bellow lines, quick disconnect fittings) at zero-g conditions
- An expansion of the data base for two-phase flow for zero-g conditions
- Development of a data base for two-phase flow for low-g conditions (e.g., Moon-g, Mars-g)
- Validation of models for two-phase flow analysis
- Providing data and models to support the Space Station Thermal Bus and future two-phase systems design

Zero-g and low-g data will be gathered using the USAF Phillips Laboratory/Foster-Miller experiment package, which is on loan to NASA/JSC for the duration of this program. Four test flight series are scheduled aboard the NASA KC-135 aircraft at Ellington Air Force Base to collect the variable gravity data. In addition, test flights will be conducted to insure that all instrumentation for the experiment package can operate adequately in the KC-135 test environment. Ground testing will be conducted at the Thermochemical Test Area (TTA) at JSC and at Texas A&M University. The package will be modified at the TTA prior to the first flight series in August 1991 and shipment of the equipment to Texas A&M for continuation of the program.

## FY91 ACCOMPLISHMENTS

Modifications to the experiment package completed include

- An added inlet length to test sections

- Fabricated bellow lines and other components
- Installed paddle wheel flowmeter, venturi flowmeters, and rotometers
- Replaced glass condenser section with copper section

Two instrument flights were completed to investigate the differential pressure transducer and the paddle wheel flowmeter operations. Both were found to operate adequately if mounted transverse in the aircraft to decrease their sensitivity to the axial accelerations. Minimal ground testing was conducted at the TTA prior to the first flight series to characterize the two-phase pump and conduct checkout of the smooth pipe and bellows lines. The first flight series using the Phillips Laboratory/Foster-Miller experiment package was conducted the week of August 19, 1991. Figure 10 shows the experiment in its test configuration aboard the KC-135. The testing consisted of 4 flight days, with 2 days each of 10.4 mm inner diameter smooth pipe and bellows lines. Data on flow regime and pressure drops in zero g was obtained. Calibrations and data reduction are in progress at Texas A&M University.

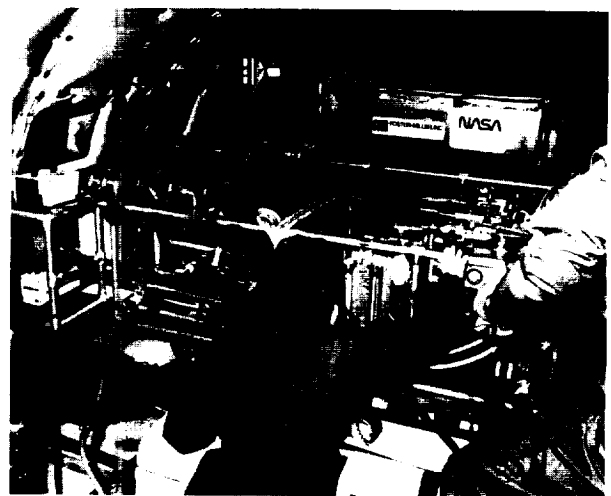

Figure 10 – USAF Phillips Laboratory/Foster-Miller Test Package aboard the KC-135.

## PLANNED FUTURE WORK

Ground testing will be conducted at Texas A&M University prior to the next scheduled flight series in November 1991. The remaining flights are described as follows:

- Series II, November 11-15, 1991, 4 flight days, zero g
- Series III, December 16-20, 1991, 4 flight days, 2 days zero g, 2 days Moon g
- Series IV, January 27-31, 1992, 4 flight days, 1 day Moon g, 3 days Mars g

Final reports and articles can be expected throughout the completion of this project, at the end of FY92.

Future Research and Technology Objectives and Plans proposals will be initiated by the NASA JSC Crew and Thermal Systems

Division relating to the development of two-phase thermal control systems for the Moon and Mars missions.

## REFERENCE DOCUMENTS

The following article has been accepted for publication in January 1992:

Dzenitis, John M.; and Miller, Kathryn M.: Two-Phase Flow Characterization for Fluid Components and Variable Gravity Conditions. Proceedings of the 9th Symposium on Space Nuclear Power Systems, January 12-16, 1992.

Additional articles and the final reports will be available in 1992.

**TITLE OF INVESTIGATION:** Hybrid Regenerative Water Recovery System (HRWRS)

**PROJECT MANAGER:** Eugene H. Winkler/EC3/(713) 483-9255

FUNDING:	FY89	FY90	FY91	(Projected)	
				FY92	FY93
In-house:	\$0	\$0	\$50k	\$300k	\$300k
Contractors:	0	0	0	0	0
Grants:	0	0	0	0	0
Total funds:	\$0	\$0	\$50k	\$300k	\$300k

**OBJECTIVE AND APPROACH**

The major objective of the HRWRS is to demonstrate that waste water can be processed into potable/hygiene quality water for reuse. The system is designed for collecting and processing waste waters from a four-person crew using both physicochemical and biological processes. The waste water is collected from shower, hand wash, laundry, and urinal sources and processed through the use of a 2-stage,

aerobic, trickling filter/biological reactor integrated with two physicochemical processes: reverse osmosis and photocatalytic oxidation. A schematic of the system is shown in figure 11. Inorganic salts are removed to less than 100 ppm and organic carbon-containing compounds are removed to less than 500 ppb. Microbial disinfection is accomplished by the photocatalytic oxidation system. Automation of system operation and data collection will be demonstrated. Data from the HRWRS will be

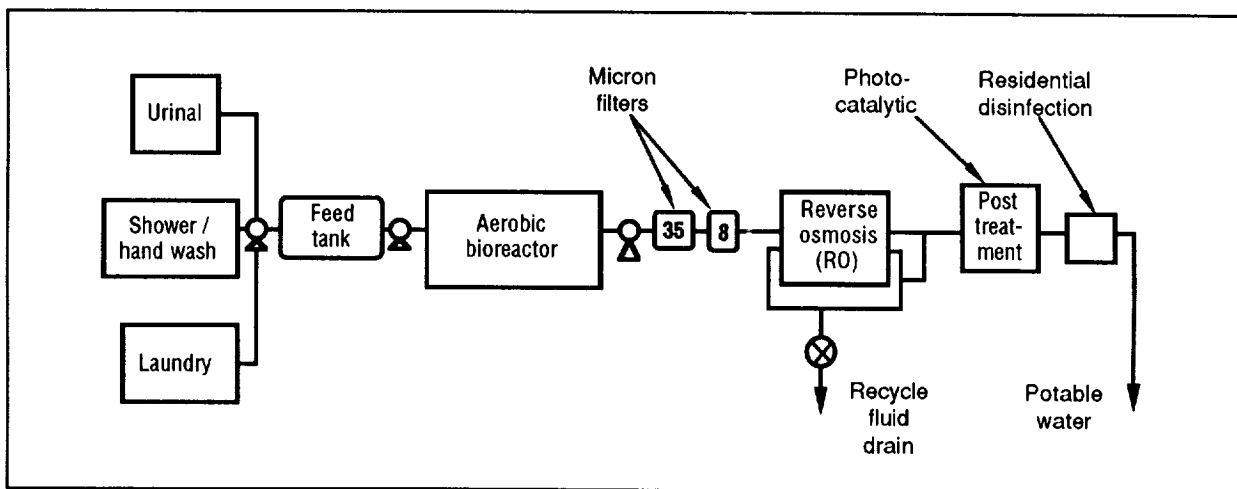

Figure 11.- HRWRS schematic.



used to define requirements for future human-rated regenerative life support system testing (ref. 1).

### **FY91 ACCOMPLISHMENTS**

Major accomplishments during FY91 included the design and construction of the HRWRS and initial component testing. The facility has been outfitted with the four waste water production sources (shower, hand wash, urinal, and laundry), three processing systems (bioreactors, reverse osmosis, and photocatalytic oxidation), and data acquisition and control systems.

### **PLANNED FUTURE WORK**

Anticipated FY92 accomplishments will include continuous testing of the HRWRS for up to 180 days. This evaluation will involve collection, processing, and complete characterization of the waste and product water. Alternate technologies for waste water treatment will be evaluated and trade studies performed. A dedicated data acquisition and control system will be purchased and integrated

with the HRWRS. An alternate post-treatment system with continuous processing capability will be investigated, designed, procured, and integrated with the system.

### **EXPECTED COMPLETION DATE**

The JSC Director's Discretionary Fund (DDF) Program portion of this project is scheduled for completion in October 1993 (i.e., 3 years of DDF support). After this date, continued funding of this project is anticipated through the Research and Technology Objectives and Plans Program.

### **REFERENCE DOCUMENTS**

1. Tri, T. O., et al.: Regenerative Life Support Systems (RLSS) Test Bed Development at NASA Johnson Space Center. Presented at the 21st International Conference on Environmental Systems, Society of Automotive Engineers, 1991.

---

---

**TITLE OF INVESTIGATION:** Programmable Remapper Interface Upgrade

**PROJECT MANAGER:** Timothy E. Fisher/EE6/483-1456

<b>FUNDING:</b>	<b>FY89</b>	<b>FY90</b>	<b>FY91</b>	<b>FY92</b>	<b>FY93</b>
In-house:	\$0	\$0	\$50k	\$0	\$0
Contractors:	0	0	0	0	0
Grants:	0	0	0	0	0
Total Funds:	\$0	\$0	\$50k	\$0	\$0

---

---

### **OBJECTIVE AND APPROACH**

The Programmable Remapper is a very capable digital image warping machine designed by NASA and constructed by Texas Instruments (TI) (ref. 1). Initial development funding did not allow completion of the video interface to required specifications. The objective of this project was to redesign the delivered video interface to allow the Programmable Remapper to interface with other hardware at the Johnson Space Center (JSC) — an optical correlator.

The approach to this effort involved a rewrite by the project engineer of the video specifications to reflect current requirements. The actual design and implementation would be completed by the original contractor that built the Remapper.

### **FY91 ACCOMPLISHMENTS**

A primary goal for this project was to have the specifications completed in the second quarter of FY91 in time for the contract modification with TI to be in place. This schedule would allow TI to make the required modifications for the Programmable Remapper to support an

aggressive summer research program at JSC. However, delays in the contract negotiations between NASA and TI resulted in the delay of contract modifications until May 1991. Due to this slip in schedule, the Remapper stayed at JSC to support the summer research program with its limited interfacing ability. At the end of the summer research program, the Remapper was shipped to TI for the required modifications. The Remapper is currently at TI. Modifications are expected to be completed in November 1991, and the Remapper returned to its research at JSC.

### **PLANNED FUTURE WORK**

No follow-on funding is requested from the JSC Director's Discretionary Fund. However, the Remapper will continue to be an active participant in the Optical Correlator Program and the Human Low-Vision Technology Utilization Program (ref. 2). In addition, an advanced version of the Programmable Remapper has been designed (ref. 3), and we are seeking funding from external sources for development. The existing Remapper is playing an important role in fostering and demonstrating the unique advantages offered by flexible video-rate image warping hardware.

## REFERENCE DOCUMENTS

1. Fisher, T. E.; Juday, R. D.: A programmable video image remapper. *Proc. SPIE*, vol. 938: 1988, pp. 122-128.
2. Loshin, D. S.; Juday, R. D.: The programmable remapper: Clinical applications for patients with field defects. *Optometry and Vision Science*, vol. 66: 1989, pp. 389-395.
3. Fisher, T. E.; Juday, R. D.: An improved architecture for video rate image transformations. *Proc. SPIE*, vol. 1098: 1989, pp. 224-231.

---



---

<b>PROJECT TITLE:</b>	Thermal Analyzer for Planetary Soils (TAPS)		
<b>PROJECT MANAGER:</b>	James L. Gooding, Ph.D./SN21/(713) 483-5126		
<b>TEAM MEMBERS:</b>	Judith H. Allton (LESC) Terry B. Byers (LESC) Keith J. Draper (LESC) Robert P. Dunn (LESC) Frank L. Gibbons (LESC) Howard V. Lauer, Jr. (LESC) Daniel B. Pate (LESC) A. James Kettle (University of Newfoundland, Canada)		
<b>FUNDING:</b>	<b>FY89</b>	<b>FY90</b>	<b>FY91</b>
In-house:	\$45k	\$43k	\$23k
Contractors:	0	2	2
Grants:	0	0	0
Total funds:	\$45k	\$45k	\$25k

---



---

## OBJECTIVE AND APPROACH

Exploration of the solar system requires compact instruments for *in-situ* analysis of water and related substances in planetary geologic materials. Motivations for such analyses include scientific investigation of the nature and histories of planetary surfaces as well as evaluation of the resource potential of planetary materials.

The TAPS project was intended to define the scope, purpose, and design considerations for miniaturized, automated instruments that would perform — through thermoanalytical methods — *in-situ* identification of ices, water-bearing minerals, and related substances in planetary surface soils. The main objective was to define the experiment

functions and performance requirements in sufficient detail that a technical proposal to the NASA Planetary Instrument Definition and Development Program (PIDDP) could be used to obtain support for development of a flight experiment.

The three important functions embodied in TAPS are: acquisition of a solid sample, thermodynamic analysis of the solid sample, and analysis of gases evolved from the sample during heating (refs. 1 and 2). The approach taken in this project was to conceptually design experiment options that would meet the needs of the most likely near-term flight opportunities. Given NASA's exploration plans in FY89, a Mars rover/sample return mission appeared to be the most probable user of TAPS in the late 1990s. Accordingly,

conceptual designs were completed in FY89 for sophisticated versions of TAPS that included a differential scanning calorimeter (DSC) as the thermodynamic analyzer (TA), and either a mass spectrometer or an infrared interferometer as the evolved-gas analyzer (EGA). In addition, a small sample-acquisition device was designed and a functional model was built and successfully tested in the laboratory (ref. 3). By FY90, however, budgetary constraints on NASA planning had displaced Mars rovers in favor of small, low-cost stationary landers. The embodiment of the multiple, small-station approach became the Mars Environmental Survey (MESUR), which is currently carried by NASA as a possible new-start space flight project for FY97.

Work performed in FY90-91 was reoriented toward designs that would serve the needs of MESUR, which had included a generic TA-EGA experiment in its strawman payload. Work in FY90 focused on the determination of TA and EGA sensitivities using laboratory instruments applied to Mars-analogous geologic samples (refs. 4 and 5). In addition, a low-cost, customized laboratory system for testing various TA-EGA sensor combinations

was designed. In view of the highly constrained mass, volume, and electrical power available to MESUR experiment packages, sophisticated multiple-function EGA systems were eliminated in favor of small, single-function water sensors. Water sensor technology was reviewed and exploratory tests were performed with a simple bench-top sensor system.

### FY91 ACCOMPLISHMENTS

The TAPS Mark-1 sensor test bed (fig. 12) was constructed from a combination of commercially available components and custom-built components. Late in FY91, a small increment of funds (\$10k) was received from the Exploration Technologies Program (NASA Headquarters, Code R) to support laboratory testing of the completed system.

The principal hardware design problem was to provide a physical interface between the DSC and the water sensors that would support transfer of purge gas while minimizing heat transfer. Toward that end, a stainless-steel manifold was designed in-house and

Figure 12.— Functional block diagram for TAPS Mark-1 sensor test bed. Six different signals comprise output from sample ( $S_x$ ,  $S_y$ ) and reference ( $R_x$ ,  $R_y$ ) sensors that measure temperature (T), water-vapor concentration (W), and differential calorimetric power (P).

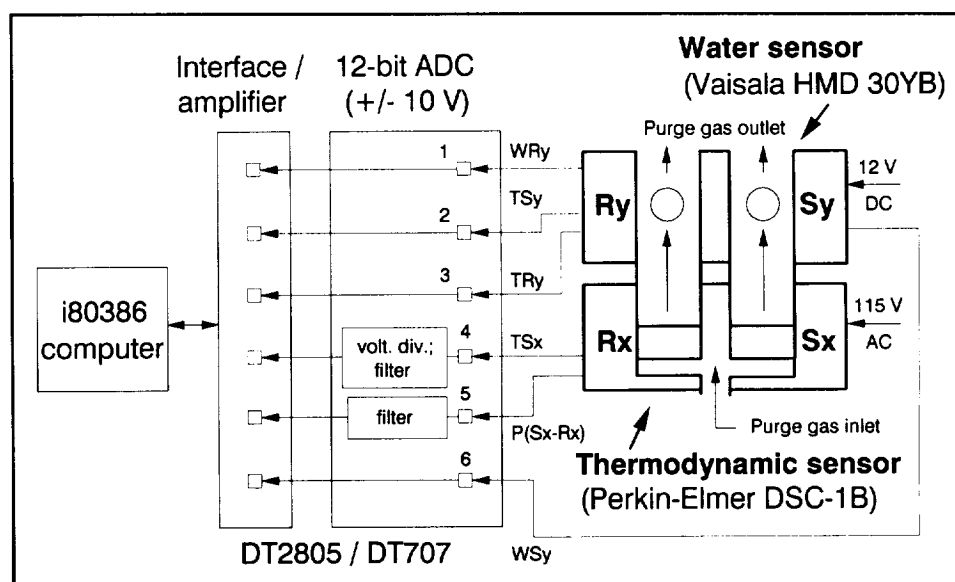

fabricated under contract with a local machine shop. The bisymmetrical manifold features two equivalent tubes that separately direct gas flow from the sample and reference sides of the DSC to their respective water sensors. Comparison of signals from the sample and reference sides defines the magnitude of water release from the sample.

A typical experimental result is shown in figure 13, which depicts the dehydration of synthetic gypsum (calcium sulfate dihydrate) in a chemically inert atmosphere. In figure 13, the water-release signal [WSy] lags behind the differential calorimetric signal [P(Sx-Rx)] as a consequence of the time delay between dehydration of the solid and conductance of the evolved water vapor past the gas sensor; the lag time can be adjusted by changes in the gas purge rate. For the calorimetric and water signals, the integrated peak areas are directly proportional to the amount of gypsum and the amount of evolved water, respectively. Work in progress includes quantitative calibration of the sensors and a parametric study of the principal variables that affect peak position, strength, and resolution. The main variables are heating

rate, purge rate, and composition of the purge gas.

## PLANNED FUTURE WORK

Additional work is needed on sample-acquisition mechanisms. The Mark-1 sample probe, although proven in principle, appears too complex for application to MESUR. Several alternative concepts are in hand but require fabrication as hardware that will permit demonstration tests. In addition, several major hardware revisions are needed to make the sensor assembly smaller, lighter, and compatible with direct loading of samples.

Work performed in FY91 completes the program of research supported by the JSC Director's Discretionary Fund. A formal technical proposal submitted to PIDDP in May 1991 requested funds, beginning in January 1992, to continue TAPS development.

Figure 13.— Representative test data for synthetic gypsum acquired with the TAPS Mark-1 sensor test bed. The various signals correspond to those identified in figure 12.

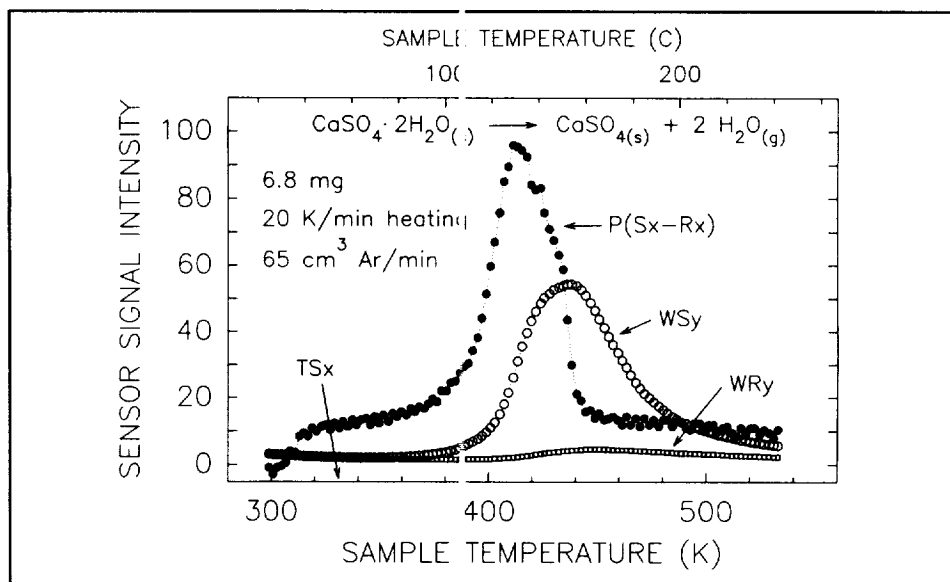

## REFERENCES

1. Gooding, J. L.: Differential scanning calorimetry (DSC) and evolved-gas analysis (EGA) applied to planetary surface exploration. In I. R. Harrison (Ed.), Proc. 18th North American Thermal Analysis Society (NATAS) Conference, vol. 1, 1989, pp. 222-228.
2. Gooding, J. L.: Thermal Analyzer for Planetary Soils (TAPS) experiment: Functions and design options. In *Lunar and Planetary Science XXII*, Lunar and Planetary Institute, Houston, Texas, 1991, pp. 457-458.
3. Allton, J. H.; Lauer, H. V., Jr.; Draper, K. J.; and Gooding, J. L.: Thermal Analyzer for Planetary Soils: Results of Initial Testing of Mark-1 Sample Probe Prototype. NASA Johnson Space Center, Houston, Texas, JSC 24572.
4. Gooding, J. L.; Kettle, A. J.; and Lauer, H. V., Jr.: DSC signatures of water-bearing geologic materials relevant to Mars and comets. In I. R. Harrison (Ed.), Proc. 19th North American Thermal Analysis Society (NATAS) Conference, vol. 1, 1990, pp. 9-15.
5. Gooding, J. L.; Kettle, A. J.; and Lauer, H. V., Jr.: DSC sensitivity to hydrated minerals in planetary samples. In *Lunar and Planetary Science XXII*, Lunar and Planetary Institute, Houston, Texas, 1991, pp. 463-464.

---

---

**TITLE OF INVESTIGATION:** Backscatter Mossbauer Spectrometer (BaMS) for Analysis of Planetary Surface Materials

**PROJECT MANAGER:** Richard V. Morris, Ph.D./SN2/FTS 525-5040

**INITIATION YEAR:** FY89

<b>FUNDING</b>	<b>FY89</b>	<b>FY90</b>	<b>FY91</b>
In-House:	\$18k	\$30k	\$30k
Contractors:	0	0	0
Grants:	12k	0	0
Total funds:	\$30k	\$30k	\$30k

---

---

## OBJECTIVES

Spacecraft missions with landers to the Moon and Mars, asteroids, and other solid solar system objects require instrumentation for analysis of surface materials. Analysis provides characterization of the surface materials and, for sample return missions, a basis for selection of representative samples. Operation of a lunar base required similar instrumentation for *in situ* resource utilization. Iron Mossbauer spectroscopy is specific for the element and sensitive to its oxidation states and chemical environment. The technique provides quantitative information on the mineralogy of iron-bearing phases and on the relative proportions of those phases. On the Moon, for example, it is an ideal probe for the mineral ilmenite, which is a source of O<sub>2</sub> for life support and He<sup>3</sup> for nuclear fusion. Because of this high selectivity to mineralogy, the inherent simplicity of the instrumentation, and no requirements for sample preparation, a BaMS is a highly viable candidate for inclusion on a surface lander. The purpose of this project is

to 1) document that backscatter Mossbauer spectroscopy can provide the necessary mineralogical data (proof-of-concept), and (2) build a brassboard instrument. Technology development areas for brassboard subsystems include miniaturization of the velocity transducer, incorporation of a solid-state detector, and testing of detector arrays (both solid state and proportional counter). This project is the basis for proposals to the Planetary Instrument Definition and Development Program (PIDDP) for full development of a flight instrument. The project is conducted by the Solar System Exploration Division for the Johnson Space Center.

## ACCOMPLISHMENTS IN FY91

For the proof-of-concept phase of the project, a research-grade Mossbauer spectrometer, capable of operation in both the normal transmission mode and in backscatter mode, was obtained during FY89. Analysis of samples pertinent to planetary applications of



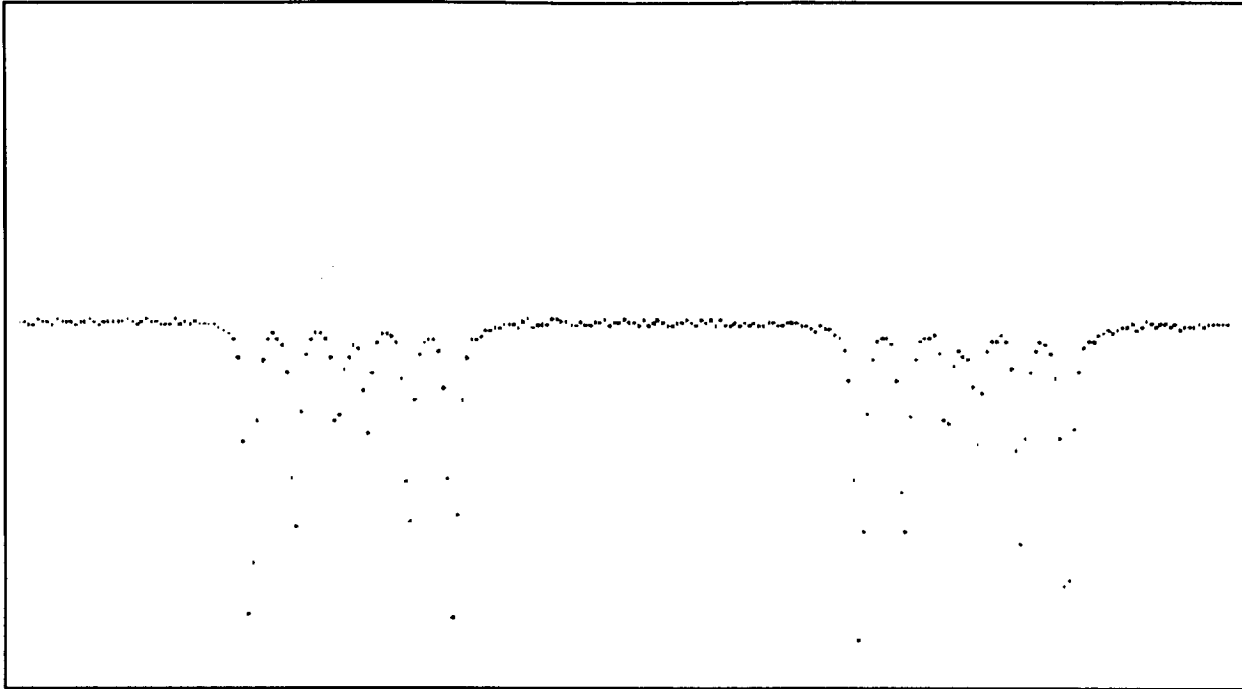

Figure 14.— Mossbauer spectrum of metallic iron foil obtained with the miniature velocity transducer operating in sinusoidal mode. Transducer specifications: size =  $1.5 \times 3.5$  cm, weight = 19 g; power < 1 mW.

Mossbauer spectroscopy is under way. Transmission Mossbauer spectra for a martian meteorite, palagonitic soils (analogues of weathered martian material), and lunar simulants have been obtained. Computer programs have been developed to parameterize the Mossbauer spectra. For the brassboard phase of the project, piezoelectric and miniaturized conventional velocity transducers were built and tested as an alternative to the bulky and heavy velocity transducer present in laboratory systems. The performance of the miniaturized conventional velocity transducer was found to be superior. A Mossbauer spectrum obtained with it is shown in figure 14. Alternative transducer designs are also under investigation. A Mossbauer spectrum was also successfully obtained with a two-detector configuration, which demonstrates the concept of multiple detector arrays for Mossbauer spectroscopy.

## PLANNED FUTURE WORK

A proposal has been submitted to the PIDDP for future funding of this project. Collection of Mossbauer spectra of putative martian surface materials will continue with an expected project completion date of September 30, 1991.

## PUBLICATIONS FROM PROJECT

1. Morris, R. V.; Agresti, D. G.; Shelfer, T. D.; and Wdowiak, T. J.: Mossbauer backscatter spectroscopy: A new approach for mineralogical analysis on planetary surfaces. In *Lunar and Planetary Science XX*, The Lunar and Planetary Institute, Houston, 1989, pp. 723-724.

2. Morris, R. V.; Agresti, D. G.; Lauer, H. V., Jr.; Newcomb, J. A.; Shelfer, T. D.; and Murali, A. V.: Evidence for pigimentary hematite on Mars based on optical, magnetic, and Mossbauer studies of superparamagnetic (nanocrystalline) hematite. *J. Geophys. Res.*, 94, 1989, pp. 2760-2778.
3. Agresti, D. G.; Wills, E. L.; Shelfer, T. D.; Iwanczyk, J. S.; Dorri, N.; and Morris, R. V.: Development of a solid state Mossbauer spectrometer for planetary missions. In *Lunar and Planetary Science XXI*, The Lunar and Planetary Institute, Houston, 1990, pp. 5-6.
4. Morris, R. V.; Gooding, J. L.; Lauer, H. V., Jr.; and Singer, R. B.: Origins of Mars-like spectral and magnetic properties of a Hawaiian palagonitic soil. *J. Geophys. Res.*, 95, 1990, pp. 14427-14434.
5. Agresti, D. G.; Shelfer, T. D.; Pimperl, M. M.; Wills, E. L.; and Morris, R. V.: Mossbauer spectrometer for planetary surfaces, *Bull. Am. Phys. Soc.*, 36, 1991, p. 627.
6. Shelfer, T. D.; Pimperl, M. M.; Agresti, D. G.; Wills, E. L.; and Morris, R. V.: Backscatter Mossbauer spectrometer (BaMS) for planetary applications: Transducer design considerations. In *Lunar and Planetary Science XXII*, The Lunar and Planetary Institute, Houston, 1991, pp. 1229-1230.
7. Agresti D. G.; Shelfer, T. D.; Pimperl, M. M.; Wills, E. L.; and Morris, R. V.: Combined backscatter Mossbauer spectrometer and X-ray fluorescence analyzer (BaMS/XRF) for planetary surface materials. In *Program and Abstracts for Clay Minerals Society 28th Annual Meeting*, 1991.

---



---

**TITLE OF INVESTIGATION:** Comparison of Continuous and Discontinuous Collisional Shields

**PROJECT MANAGER:** Friedrich Hörz/SN2/(713) 483-5042  
(Projected)

<b>FUNDING:</b>	<b>FY89</b>	<b>FY90</b>	<b>FY91</b>	<b>FY92</b>	<b>FY93</b>
In-house	\$0	\$0	\$35k	\$50k	Program- Source
Contractors	0	0	0	0	?
Grants	0	0	0	0	
Total Funds	0	0	\$35k	\$50k	0

---



---

**OBJECTIVE AND APPROACH**

Natural particles and man-made debris combine into a substantial collisional hazard to spacecraft in low Earth orbit, even more so, if future activities in space would cause the man-made particle population to increase (ref. 1). Traditionally, contiguous sheets of material are employed as protective shields that will destroy the hypervelocity impactors by shock-induced vaporization, melting, or fragmentation. The mass contained in such shields or "bumpers" translates into launch mass and has, therefore, not only practical limits, but substantial fiscal and operational consequences. The thrust of past and ongoing bumper developments is, therefore, to devise the most lightweight bumpers possible (ref. 2).

The intent of this work is to verify theoretical expectations that the initialization of a shock wave in the impactor does not require a target that is laterally continuous beyond typical projectile dimensions. Grid-like structures may suffice, provided their mesh-opening ( $M$ ) is smaller than the projectile diameter ( $D_p$ ) to assure contact with the bumper. A series of meshes that have progressively smaller mesh-openings and wire thicknesses seems especially

promising because they would progressively comminute and decelerate the fragments generated by the first, most massive grid (ref. 3).

Suitable impact experiments were conducted using powder propellant and light gas gun ballistic ranges to accelerate spherical soda-lime glass projectiles, some .13 in. or .25 in. in diameter, to velocities between 1 and 6 km/s. They impacted targets of carefully controlled thicknesses that were dimensionally scaled to  $D_p$ , such as  $D_p/T = 2, 5, \text{ and } 10$ . Both continuous and grid targets were exposed for direct comparison. A few experiments with multiple mesh targets were performed as well at 6 km/s.

**RESULTS OF FIRST YEAR INVESTIGATIONS (FY 91)**

As documented in a detailed report (ref. 4), the equivalence of  $T$  for both bumper designs could be demonstrated. The largest secondary crater on witness plates represents the most kinetic fragment ( $F_{max}$ ) and, thus, the most serious remaining threat to a flight system. Neither continuous nor discontinuous bumpers produced a single, outstandingly kinetic fragment — but instead, a fair number

(  $N > 10$  typically) of similar sized, large fragments. Importantly,  $F_{\max}$  does not systematically vary between continuous and discontinuous targets at identical  $T$ . This demonstrates that grid bumpers collisionally fragment the impactor with the efficiency of continuous shields as postulated. The grid bumpers outperform the continuous targets in every category of displaced mass that was measured, such as total target mass displaced or the physically recovered total ejecta and spall products. The uneven mass distribution of grid bumpers, however, leads to localized clustering and clumping of secondary craters, a distinctly unfavorable property. A few exploratory experiments exposing multiple meshes reveal that multiple shocks not only

induce additional, progressive comminution, but that they also result in substantially increased dispersions of the relatively fine-grained debris. Thus, most theoretical predictions of single-grid penetrations could be verified experimentally, and grid-like materials seem suitable for collisional bumpers. Figures 15 and 16 illustrate representative results of the total of 45 impact experiments conducted to date.

### PLANNED FUTURE WORK

Efforts in year two will extend these experiments to multiple, successive grids and to specific detail of grid design, such as round

Figure 15.— Representative grid penetrations at three different impact velocities employing custom-made grids manufactured from welding rods that have identical center-to-center mesh distances ( $M = D_p = .13$  in.), yet two different scaled thicknesses  $D_p/T = 2$  and  $5$ . Note that target damage increases with velocity; also, total displaced target mass decreases with increasing  $D_p/T$  (e.g., compare experiments #803 and #806).

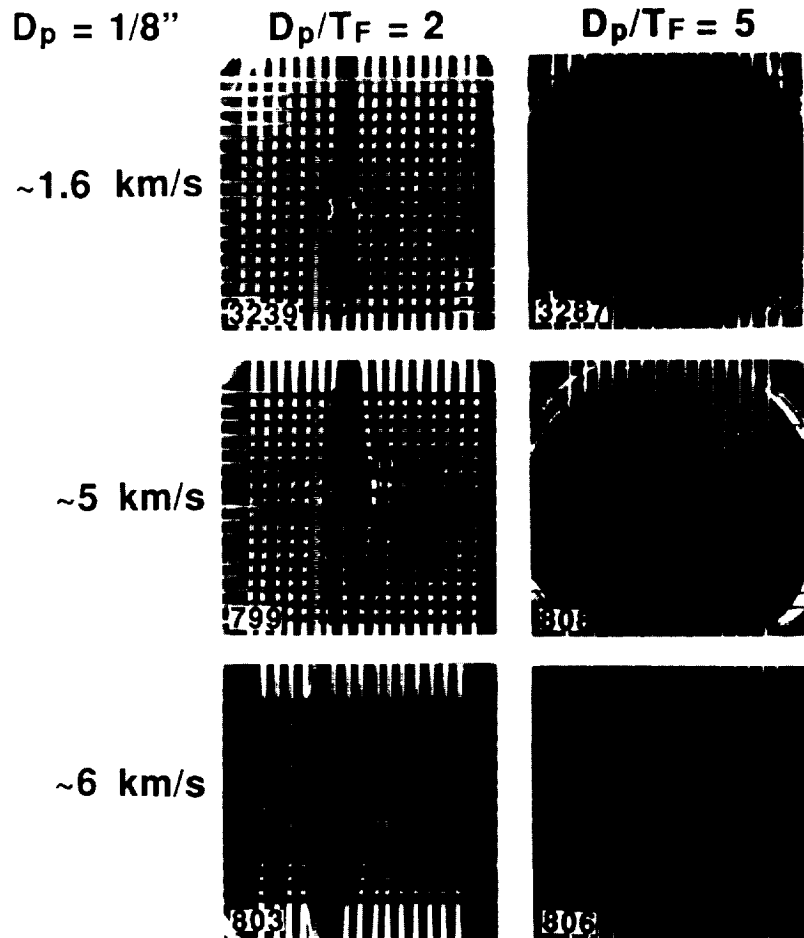
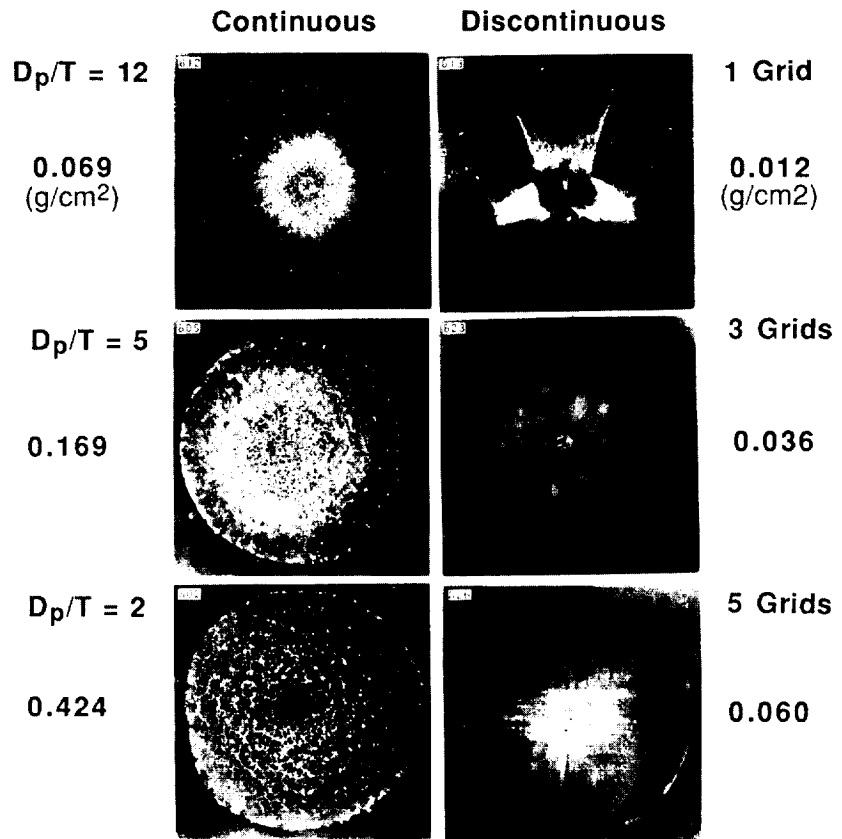

Figure 16.— Rear-witness plates simulating flight systems that are damaged by debris particles generated during the penetration of single membranes and multiple grids (all at 6 km/s, using .13 in. projectiles). Note the degree of damage as a function of absolute areal shield mass (g/cm<sup>2</sup>) and that the grid bumper vastly outperforms the continuous shield at equivalent mass (e.g., #812 versus #826).



profiles and weaves versus regular machined or etched grids of square cross-section. At the end of year two, it is expected that the utility of discontinuous bumpers is demonstrated. This effort must be viewed as basic experimental inquiry, rather than as a development of flight systems. The latter will be a major, collaborative undertaking of many individuals and laboratories.

## REFERENCES

1. Kessler, D. J.: Orbital Debris Environment for Spacecraft in Low Earth Orbit. *J. Spacecraft*, vol. 28, 3, 1991, pp. 347-351.
2. Christiansen, E. L.: Advanced Meteoroid and Debris Shielding Concepts. AIAA/NASA/DOD Orbital Debris Conference, 1990, AIAA 90-136.
3. Hörz, F.: Discontinuous Meteorite Bumper, Disclosure of Invention. MSC-21769-1, NASA JSC, 1990.
4. Hörz, F.: Comparison of Continuous and Discontinuous Bumpers for Collisional Protection of Spacecraft. DDF Progress Report, 1991.

---

---

**TITLE OF INVESTIGATION:** Lymphocyte Activation in Simulated Microgravity and Hypergravity

**PROJECT MANAGER:** Clarence F. Sams, Ph.D./SD4/(713) 483-7160

<b>FUNDING:</b>	<b>FY89</b>	<b>FY90</b>	<b>FY91</b>	<b>FY92</b>
In-house:	\$50k	\$35k	\$30k	\$0
Contractors:	0	0	0	0
Grants:	0	0	0	0
Total funds:	\$50k	\$35k	\$30k	\$0

---

---

## **OBJECTIVE AND APPROACH**

Lymphocytes have been repeatedly examined during space flight and in ground-based experiments and have consistently demonstrated an apparent gravitational influence on *in vitro* activation with mitogenic lectins (ref. 1). While these data have reproducibly demonstrated an effect of gravity on lymphocyte activation, it is impossible to determine the operative mechanisms from these studies. Gravity may affect any of a number of critical events regulating progression through the activation cascade. In addition, *in vitro* activation of lymphocytes has a demonstrated sensitivity to alterations in cell culture environment, such as cell concentration and culture vessel geometry. Changes in these characteristics may accompany culture in non-unit gravity. We hypothesize that gravity influences lymphocyte activation through one or both of the following general mechanisms: 1) alteration of the cell culture environment (e.g., cell-cell or cell-substrate contact) or 2) changes in specific elements of the activation cascade. The objective of this task was to examine these alternatives and determine the

mechanisms responsible for the gravity sensitivity of the activation response.

All experiments in this study were performed in the Biomedical Operations and Research Laboratories of the Johnson Space Center. The studies required significant capability for biochemical and molecular analysis of cells. The laboratory facilities included equipment for tissue culture, biochemical analysis, radioisotope work, fluorescence microscopy, and flow cytometry. During the course of the research, enhancement of specific capabilities was required to support the ongoing research. These included addition of multiparameter analysis hardware to the flow cytometer, support for acquisition of a new fluorescence microscope, and additions to tissue culture and molecular analysis equipment.

## **FY91 ACCOMPLISHMENTS**

Early experiments (FY89 and FY90) focused on the effects of culture environment-induced changes on activation. Previous reports have documented a significant decrease in mitogen

activation of lymphocytes during culture in clinostats. These results have been attributed to a reduction of the apparent gravity on the cells to approximately 1/100 g or less by the clinorotation at appropriate speeds. An alternative explanation is that clinostats evenly disperse the cells and interfere with the cell-cell and cell-surface interactions required for mitogen-driven activation. To test whether simple dispersion was sufficient to inhibit activation, we treated lymphocytes with 2  $\mu\text{g}/\text{ml}$  PHA while either static or maintained in suspension on a hematology rocker. The hematology rocker provided gentle suspension without the microgravity simulation of clinorotation. Suspending the cells caused a 60 to 70 percent decrease in T cells expressing the CD69 activation marker (fig. 17a) compared to the static control. Tritiated thymidine uptake at 48 hours was also decreased by 50 to 60 percent. No decrease in the viability of the suspended sample was observed as determined by propidium iodide staining and

flow cytometry. These results suggest that dispersion of the cells is sufficient to account for the decreased responsiveness observed in clinostats without requiring the contribution of *hypogravity* effects. In addition, these data indicate that early events in the activation sequence are affected by changes in culture environment when surface-active mitogens are used.

Phorbol esters function as direct activators of protein kinase C (PKC) and, in conjunction with appropriate accessory signals, are effective activators of peripheral lymphocytes. These compounds bypass the initial cell surface-mediated signaling events and provide an alternate means for activating the cells, potentially independent of surface contact. Preliminary studies have shown that treatment of lymphocytes with 50 ng/ml phorbol myristate acetate (PMA), either static or suspended, induced the expression of CD69 on approximately 90 percent of the T

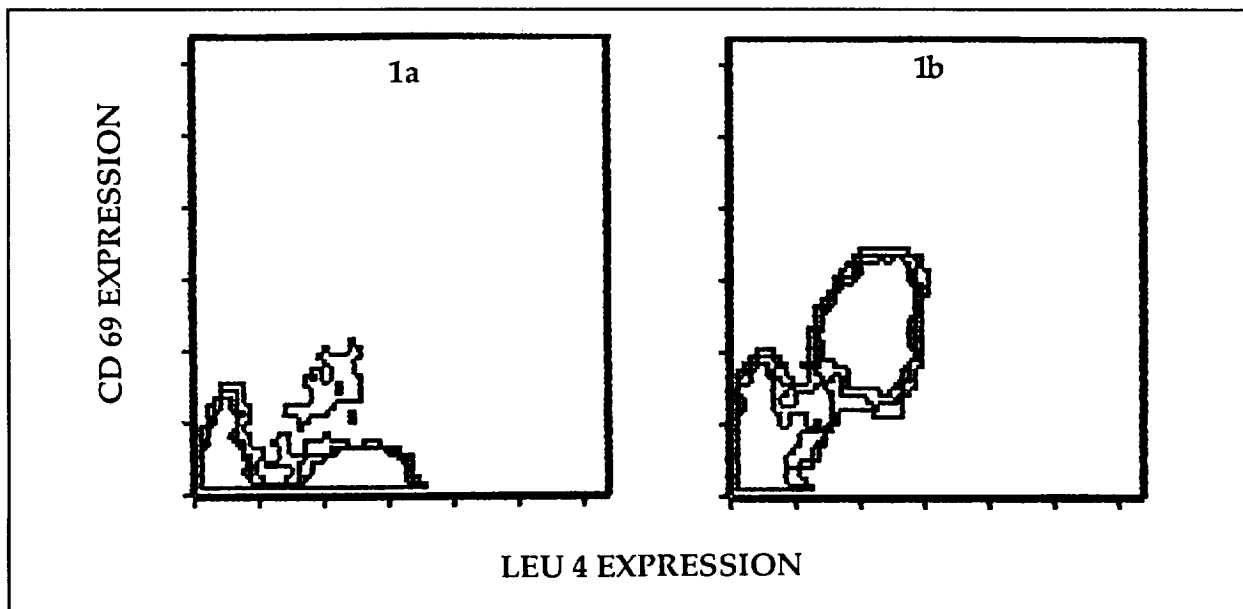

Figure 17.— Activation of suspended lymphocytes. Peripheral lymphocytes were activated with the surface active mitogen, PHA (fig. 17a), or the phorbol ester, PMA (fig. 17b) while in suspension on a hematology rocker. The expression of the CD69 activation marker is along the vertical axis, and the expression of the T-cell marker, leu 4, is along the horizontal axis. The activated T cells are those expressing both the CD69 and leu 4 markers.

cells after 24 hours (fig. 17b). The lack of sensitivity to the degree of cell dispersion observed with PMA indicates that bypassing the receptor-mediated signaling mechanisms allows the initiation of early activation events in the suspended state. These results further support our hypothesis that the early surface-mediated events may be critical determinants in the apparent gravity sensitivity of lymphocyte activation.

From the above results it is apparent that environmental or indirect effects have significant impact on mitogen activation and may account for a significant portion of the observed effects in clinostats or microgravity. These effects can be observed at very early points during the sequence of activation events and are different for surface active mitogens and transmembrane active mitogens. Overall, the preliminary data confirm the validity of examining the activation sequence with different mitogens and culture conditions to determine specific cellular mechanisms which are potentially responsive to direct or indirect effects of altered gravity.

#### PLANNED FUTURE WORK

The studies outlined above provided the basis for a new research proposal entitled

“Mechanisms of Altered Lymphocyte Activation in Simulated Microgravity and Hypergravity,” which was submitted in response to a NASA Research Announcement for Gravitational Biology (NRA-91-OSSA-15). The proposed research will focus on the effects of altered gravity and cell culture environment on the early signal transduction pathways involved in T-cell activation. Specific signaling pathways which are critical to activation include the inositol phosphate pathways, intracellular calcium levels, protein phosphorylation, oncogene expression, and modulation of cytoskeletal structure. These studies will provide critical insight into environmental and cellular factors responsible for the gravity sensitivity of a cell in culture.

#### REFERENCE DOCUMENT

1. Grunder, F. K.; and Cogoli, A.: 1988. *App. Micrograv. Tech.*, vol. 1, pp. 115-122.



**TITLE OF INVESTIGATION:** Evaluation of New Body Composition Techniques in Variable G's

**PROJECT MANAGER:** Steven F. Siconolfi, Ph.D./SD5/(713) 483-7110

FUNDING:	FY89	FY90	FY91	(Projected)	
				FY92	FY93
In-House:	\$40k	\$30k	\$5k	\$0	\$0
Contractors:	0	0	0	0	0
Grants:	0	0	0	0	0
Total funds:	\$40k	\$30k	\$5k	\$0	\$0

**OBJECTIVE AND APPROACH**

The development of new methodologies that can measure changes in body fluids and lean mass (muscle) is the cornerstone for evaluating microgravity-induced changes in body composition with Siri's (ref. 1.) 3-compartment model (water, dry lean mass, and fat mass).

This project evaluated estimates of total body water and new techniques to measure body volumes. Three basic approaches were undertaken to meet this objective.

- Characterize the bioelectrical responses of the body with different skin temperatures, input frequencies, and electrode configurations relative to body positions.
- Examine the relationships between bioelectrical responses to low voltage, multi-frequency electrical inputs and body fluid compartments (total body water, extracellular fluid volume, and plasma/blood volume). Develop new bioelectrical models for the estimation of body fluids.
- Develop a system to measure limb and body volumes utilizing compliance

volumenometry. Expand the system (if possible) to measure limb blood flow.

**ACCOMPLISHMENTS IN FY91**

- Developed a new bioelectrical model for estimating total body water (ref. 2.) The new model has comparable estimation abilities for subjects with larger (>40 l) measures of total body water, but has improved (47 percent reduction of error rate) the assessment for subjects with smaller measures of total body water (fig. 18).
- A measurement system for limb volume has been completed with an average error of less than 0.15 percent (fig. 19).
- A measurement system for detecting the change in limb volume (fig. 20) and blood flow (using occlusion plethysmography) has been completed with an average error of 1 percent (fig. 21).
- A patent application has been filed for the limb compliance volumenometer.

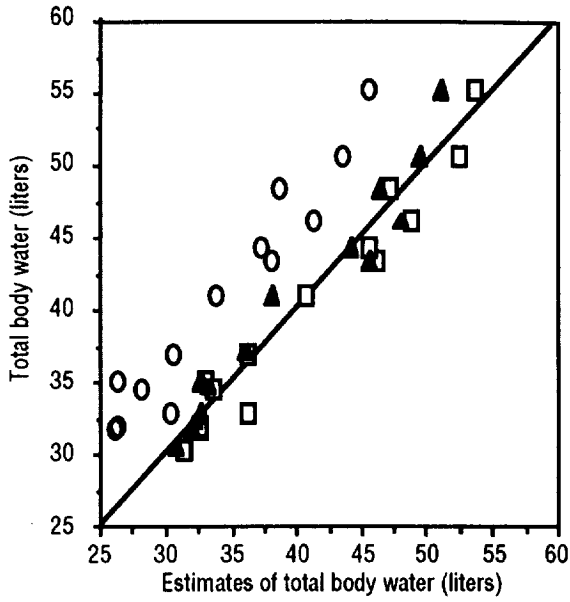

Figure 18.— Comparison of bioelectrical resistance estimates of total body water with true (O-18 labeled water) measures in 14 subjects. Estimates of total body water were made with regression equations from Lukaski, et al. [O] (ref. 3, Kushner & Schoeller [□] (ref. 4), and from the new [▲] 3rd order polynomial model.

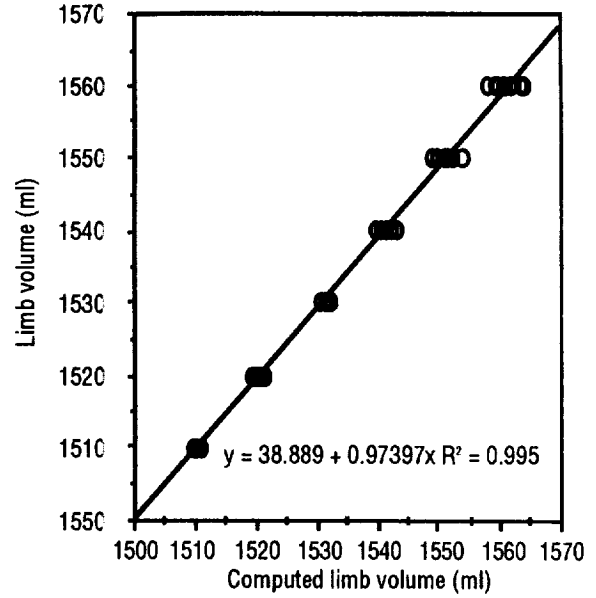

Figure 19.— Comparison of limb volumes (simulated) to computer limb volumes using compliance volumenometry. The mean error rate for these measures was less than 0.15 percent.

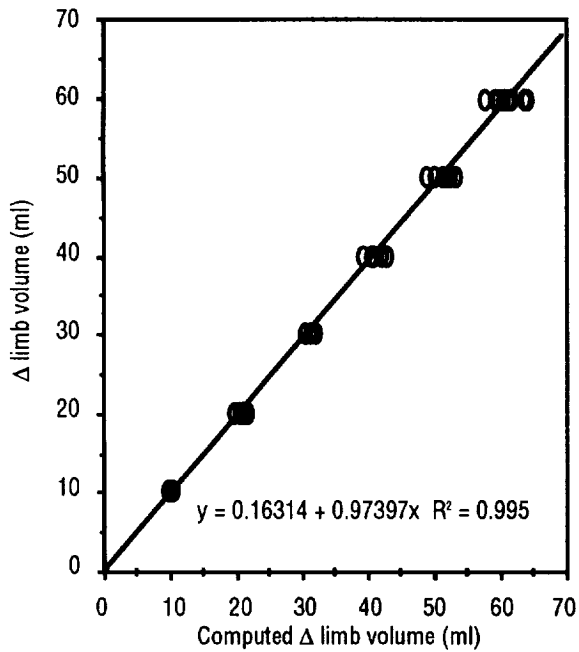

Figure 20.— Comparison of the change in limb volume to the computed change in limb volume using compliance volumenometry. The mean error rate for these measures was less than 1 percent.

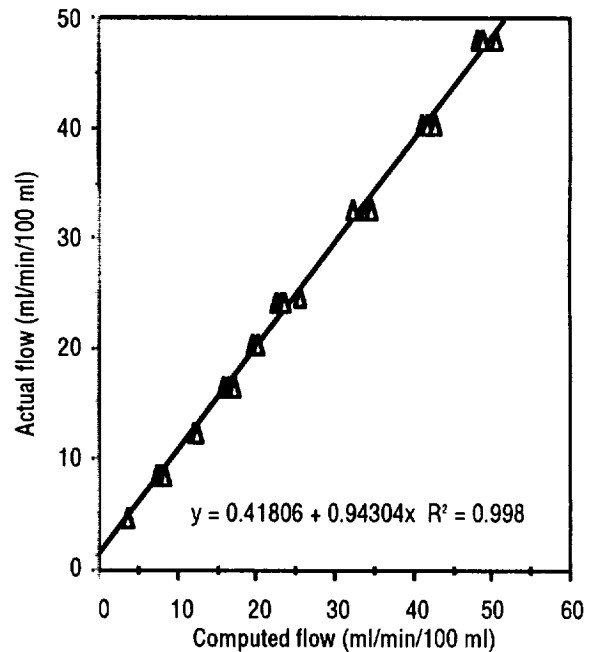

Figure 21.— Comparison of the limb blood flow (simulated) to the computed limb blood flow using compliance volumenometry. The mean error rate for these measures was less than 1 percent.

- Use of gas dilution for total body volume was not effective.
- A pressure volumenometer (whole body plethysmography) for measuring body volume was initially evaluated and shows promise.

#### PLANNED FUTURE WORK

- Completion of data collection for evaluation of blood and extracellular fluid volumes from bioelectrical responses.
- Further evaluation of the pressure volumenometer.

2. Siconolfi, S. F., Kear, K.T.: A New Model for Estimating Total Body Water from Bioelectrical Resistance. Submitted for presentation at the Aerospace Medicine Association Meeting, 1992.
3. Lukaski, H. C., Bolonchuk, W. W., Hall, C. B., Siders, W. A.: Validation of tetrapolar bioelectrical impedance method to assess human body composition. *J. Appl. Physiol.*, vol. 60: 1986, pp. 1327-32.
4. Kushner, R., Schoeller, D.: Estimation of total body water by bioelectrical impedance analysis. *Am. J. Clin. Nutr.*, vol. 44: 1986, pp. 414-24.

#### REFERENCE DOCUMENTS

1. Siri, W.E.: Body Composition from Fluid Spaces and Density: Analysis of Methods. Report 19. Berkeley, CA. University of California Press, 1956.

---

---

**TITLE OF INVESTIGATION:** Plasma Volume and Orthostatic Tolerance

**PROJECT MANAGER:** Suzanne M. Fortney, Ph.D./SD5/FTS 525-7213  
(Projected)

<b>FUNDING:</b>	<b>FY89</b>	<b>FY90</b>	<b>FY91</b>	<b>FY92</b>	<b>FY93</b>
In-house:	\$60k	\$60k	\$60k	\$0k	\$0k
Contractors:	0	0	0	0	0
Total funds:	\$60k	\$60k	\$60k	\$0	\$0

---

---

### **OBJECTIVE AND APPROACH:**

Hyatt and West (ref. 1) have shown that a 4-hour continuous exposure to -30 mmHg lower body negative pressure (LBNP) and the simultaneous ingestion of 1 l of an isotonic saline solution will restore plasma volume (PV) and orthostatic responses (OR) for up to 18 hours following 1 week of simulated space flight (bedrest(BR)). The objective of this project is to develop the optimum protocol (LBNP profile and rehydration solution) which restores PV and OR for at least 24 hrs with a minimum time, commitment, discomfort, and risk. To accomplish this goal, the optimum LBNP pressure, pressure profile, and exposure time must be determined. Once the protocol is established, it can be immediately implemented into ongoing flight studies (DSO 478).

### **ACCOMPLISHMENTS**

#### **1988**

A 13-day BR study was performed by 10 healthy, young men. Each subject underwent a single, 13-day, 6° head-down BR, in which the protocol of Hyatt and West (a 4-hour continuous exposure to -30 mmHg and ingestion of 1 l of isotonic saline) was performed.

Also, each subject underwent a shortened 2-hour treatment. The subjects were randomly assigned to groups A and B. Group A received the 4-hour treatment first and the 2-hour treatment later. Group B received the 2-hour treatment first and the 4-hour treatment later. The objectives of this study were: 1) to verify that the 4-hour treatment will improve PV and OR for at least 24 hours, and 2) to determine whether the 2-hour treatment would be equally effective.

The results of this study were reported in the JSC Director's Discretionary Fund Program 1989 Annual Report. Both 2-hour and 4-hour treatments expanded PV for up to 24 hours after treatment. However, significant improvement in OR was only seen after the 4-hour treatment. Therefore, the project team recommendation was to continue to manifest the 4-hour protocol. To date, four Shuttle crewmembers (two from STS-32 and two from STS-43) have performed this protocol.

#### **1989**

After verifying the effectiveness of the 4-hour LBNP treatment in men, the project team was asked to repeat the study in women. Ten women were recruited to perform an identical BR protocol as that of the 1989 study of male

subjects. However, instead of repeating the 2-hour, continuous -30 mmHg LBNP treatment, the pressure profile of the 2-hour treatment was altered. We hypothesized that changing from a continuous -30 mmHg pressure to a constantly changing pressure profile (sinusoidal pressure profile with pressure changing from 0 to -60 mmHg each minute) would be more effective in 1) stimulating fluid retention, 2) stimulating carotid baroreceptor function, and 3) restoring lower body venous compliance. Therefore, a sinusoidal LBNP treatment might be more effective in restoring PV and improving OR.

Again, we found that both 2-hour and 4-hour LBNP treatments restored PV. However, the effectiveness of even the 4-hour continuous LBNP treatment to restore OR was less consistent in women. The heart rate and stroke volume responses to LBNP of only 4 out of 10 of the women were improved 24 hours after the 4-hour treatment. The 2-hour sinusoidal LBNP treatment was found to be equally effective – with improvement in OR evident in 4 of the 10 subjects. There appeared to be no correlation between menstrual cycle stage at the time of treatment and the effectiveness of treatment.

Our conclusions from this study were equivocal. It appears that the effect of the 4-hour LBNP treatment may be less consistent in women. Womens' body fluid responses are altered by hormones associated with the menstrual cycle. It is possible that these effects cause variations in PV and OR which override the effects of BR or countermeasure treatment.

## 1990

A 6-day BR study evaluated the 2-hour sinusoidal LBNP countermeasure. The purposes of this study are: 1) to determine whether a 2-hour sinusoidal LBNP treatment will restore PV and ORs after 5 days of BR, and 2) to determine whether the 2-hour sinusoidal

treatment is more effective if the saddle of the LBNP device is removed and pressure is applied to the feet during each sinusoidal pressure fluctuation. The hypothesis is that periodically stimulating the lower body musculature may improve countermeasure effectiveness to restore skeletal muscle tone, possibly venous tone, and thus better improve OR after BR.

The protocol for this study involves 12 subjects each undergoing two 6-day hospitalizations. On one day of ambulatory baseline, PR-BR measurements of PV and ORs are obtained during a presyncopal limited LBNP test. During one hospitalization (control BR), no treatment is given. After 5 days of BR, an LBNP test is administered to evaluate OR. During the second BR (treatment BR), the 2-hour sinusoidal LBNP treatment is administered on BR day 4. Twenty-four hours later, the post BR LBNP test is administered to evaluate OR.

To date, three subjects have completed both BRs, and three additional subjects have completed a single BR (two controls and one treatment). Treatments have all been with saddle support. In all subjects who have received the sinusoidal LBNP treatment except one, PV was increased during BR after treatment. The subject who had no improvement had gastrointestinal (GI) problems throughout both BRs, which may have accounted for his lack of response to treatment. Of the three subjects who have completed both BRs, two have had improvement in their post-BR orthostatic tolerance. The third subject had GI problems.

The results from this study, thus far, are promising. It is anticipated that the 2-hour sinusoidal LBNP treatment may prove at least as effective as the 4-hour continuous pressure treatment and may soon be substituted in the ongoing Shuttle countermeasure program (DSO 478).

## PLANNED FUTURE WORK

The sinusoidal LBNP countermeasure study is targeted for completion within the next 6 months. In addition, the effectiveness of the countermeasure may be improved by substituting a rehydration solution which does not contain sodium (sodium in the rehydration solution may decrease aldosterone secretion and retard fluid retention during the 24-hour interval after treatment). Funding for these additional studies has been obtained from the cardiopulmonary Research and Technology Objectives and Plans Program.

## REFERENCE

1. Hyatt, K. H.; and West, D. A.: Reversal of bedrest-induced orthostatic intolerance by lower body negative pressure and saline. *Aviat. Space Environ. Med.* 48: 1977, pp. 120-124.

## PUBLICATIONS FROM THIS PROJECT

Fortney, S. M.: Development of Lower Body Negative Pressure as a Countermeasure for Orthostatic Intolerance. In press. *J. Clinical Pharmacology*.

Melchior, F. M.; and Fortney, S. M.: Measurement of leg compliance using mercury strain gauge and thigh occlusion during bedrest. Submitted to *J. Appl. Physiol.*

Wood, M.; Dussack, L. G.; Fortney, S.: Orthostatic responses during lower body negative pressure with and without saddle support. *Aviat. Space Environ. Med.* 62:472, 1991.

Fortney, S. M.; Troell, M.; Dussack, L.; and Cintron, N. M.: Plasma volume, fluid balance, and endocrine responses to prolonged lower body negative pressure during bedrest. *FASEB J.* 5: A1015, 1991.

Bondar, R. L.; Kassam, M. S.; Stein, F.; Dunphy, P. T.; Fortney, S.; and Charles, J.: The usefulness of transcranial Doppler in predicting loss of orthostatic tolerance during lower body negative pressure. *Aviat. Space Environ. Med.* 62: 469, 1991.

Jones, M.; Dussack, L.; Rehbein, T.; Fortney, S.; Charles, J.; and Bungo, M.: Evaluation of prolonged lower body negative pressure and saline ingestion on restoring orthostatic responses during bedrest. *Aviat. Space Environ. Med.* 61: 470, 1990.

Rehbein, T.; Dussack, L.; Jones, M.; Lanehart, D.; Fortney, S.; Charles, J.; and Bungo, M.: Cardiovascular response to prolonged lower body negative pressure and isotonic saline ingestion. *Aviat. Space Environ. Med.* 61:469, 1990.

Dussack, L.; Rehbein, T.; Steinmann, L.; Fortney, S.; Charles, J.; and Bungo, M.: Effect of 13 days of bedrest on cardiac responses during presyncopal lower body negative pressure. *Aviat. Space Environ. Med.* 61: 490, 1990.

Melchior, F. M.; and Fortney, S. M.: Changes in leg compliance during a 12-day bedrest study. *Aviat. Space Environ. Med.* 496, 1990.

**TITLE OF INVESTIGATION:** Determining Human Energy Utilization During Space Flight Using Doubly Labeled Water

**PROJECT MANAGERS:** Helen W. Lane, Ph.D.  
SD4/Biomedical Operations & Research 483-7188

Everett K. Gibson, Ph.D.  
SN21/Planetary Science 483-6224

Randall J. Gretebeck, Ph.D.  
NRC Postdoctoral Associate  
SD4/Biomedical Operations & Research 483-9945

FUNDING:	FY89	FY90	FY91	(Projected)	
				FY92	FY93
In-house:	\$0	\$50k	\$50k	\$60k	\$0
Contractors:	0	0	0	0	0
Grants:	0	0	0	0	0
Total funds:	\$0	\$50k	\$50k	\$60k	\$0

## OBJECTIVE AND APPROACH

Exposure to microgravity induces physiological and biochemical changes that may interfere with the health and normal functioning of humans in space. For example, by the end of a flight, a crewmember's energy stores may be insufficient for unaided egress in an emergency. The availability of nutrients from food and the energy (calories) required in microgravity may differ from the availability of nutrients and energy that would be required on the ground. Traditional methods for calculating human energy utilization are difficult or impossible to perform in space. This project seeks to 1) use water labeled with the stable isotopes deuterium and oxygen-18 to measure energy utilization noninvasively in humans and to 2) develop this technology to measure the energy used by crewmembers during space flight. In service of this goal, the

first objective was to build and test the analytical systems necessary to purify hydrogen and oxygen from human blood, urine, and saliva samples. From these data, models will be developed to use doubly labeled water as a means of calculating the energy used in performing specific activities in space.

## ACCOMPLISHMENTS

The components of the isotope purification system were obtained in FY90; the system for oxygen analysis was completed and tested in FY90/91. A state-of-the-art, stable-isotope laboratory with the capability of performing the sophisticated techniques involved in doubly labeled water analyses is now in place. Pilot studies to validate the precision and accuracy of the oxygen and hydrogen purification systems included, respectively, splitting samples

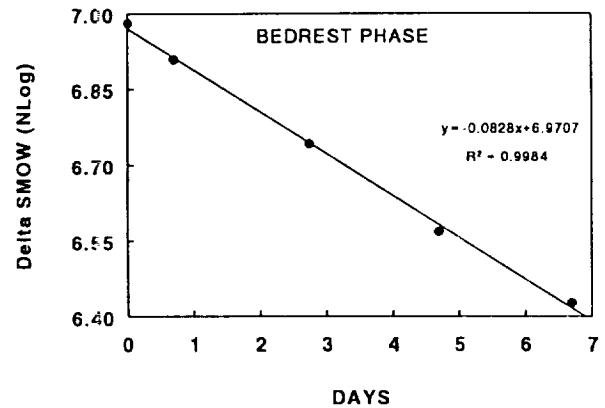
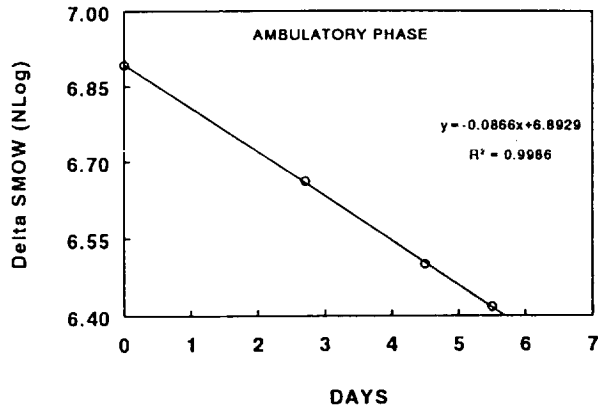

Figure 22.— Deuterium elimination rate, energy/GI men's bed rest study.

and comparing the results with those of an established, independent laboratory and using international water standards. A methodological study of our oxygen analytical method, which uses a novel approach, was presented at the International Conference on Geochronology, Geochemistry, and Isotopic Geochemistry in Canberra, Australia, in 1990; a report is currently in review for publication in *Analytical Chemistry*. Another series of studies is under way to establish baseline isotope concentrations in the Orbiter water. The water produced during flight by the fuel cells, which is used by the crew for drinking and food preparation, has been found to have higher concentrations of deuterium and

oxygen-18 than the normal ground water used to fill the Orbiter tanks before launch.

Another ongoing study, supported by extended duration Orbiter (EDO) funds, is under way to measure energy utilization in adult men during bed rest. Figure 22 shows the deuterium elimination rate in one subject for both the ambulatory and bed rest phase of the study. This project is expected to end in FY92. Another experiment, supported by Research and Technology Objectives and Plans Program funds, involves testing the effects of drinking water that has been enriched with isotopes to simulate the enrichment of Orbiter water. Figure 23 shows the oxygen-18 elimination rate in a subject consuming simulated Orbiter water. Finally, an EDO-supported flight experiment will use doubly labeled water to measure energy utilization in 36 crewmembers during space flight. This study has been manifested on STS-45 and is under consideration for STS-47.

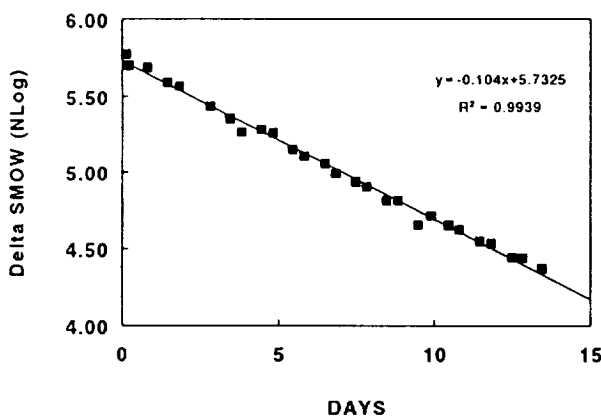

Figure 23.— Oxygen-18 elimination rate, women's study - subject 1.

## PLANNED FUTURE WORK

The current, ground-based studies will be completed in FY92. In other studies, models will be developed to aid prediction of isotopic elimination during the unique circumstances of



space flight. The oxygen purification system will be modified to accommodate microliter sample sizes in order to maximize use of physiological samples collected during flight. Another EDO proposal to continue tracking the enrichment of Orbiter water will be submitted in FY92. The flight study will continue until 36 subjects have been tested.

2. Wong, W. W.; and Klein, P. D.: A review of techniques for the preparation of biological samples for mass-spectrometric measurements of hydrogen-2/hydrogen-1 and oxygen-18/oxygen-16 isotope ratios. *Mass Spectrometry Reviews*, vol. 5, 1986, pp. 313-342.

## REFERENCE DOCUMENTS

1. Schoeller, D. A.; Field, C. R.; and Brown, K. H.: Energy expenditure by doubly labeled water: Validation and clinical application. In: *Synthesis and Applications of Isotopically Labeled Compounds*, Muccino, R. R., ed. Amsterdam: Elsevier Science Publications, 1985.

---

---

**TITLE OF INVESTIGATION:** Search Coil System to Record Eye Movements For Studies of Eye, Head, Hand Coordination

**PROJECT MANAGER:** Jacob J. Bloomberg, Ph.D./SD5/(713) 483-0436

<b>FUNDING</b>	<b>FY91</b>	<b>FY92</b>	<b>FY93</b>
In-house:	\$50k	\$30k	\$15k
Contractors:	0	0	0
Grants (Research and Technology Objectives and Plans):	0	75k	75k
<b>Total Funds:</b>	<b>\$50k</b>	<b>\$105k</b>	<b>\$90k</b>

---

---

## **OBJECTIVE AND APPROACH**

The central nervous system integrates multi-sensory information to determine body spatial orientation relative to the environment. Exposure to microgravity during space flight induces alteration in this internal construct producing perceptual and sensory-motor disturbances during adaptation to zero g and readaptation to a one-g environment. With plans for extended duration missions (specifically, involving development of the proposed Space Station and future missions to Mars), these alterations in perceptual and sensory-motor constructs are of particular importance.

The ability to accurately coordinate eye, head, and hand movements is essential for safe Shuttle operation. Astronauts' vestibular responses are known to change both on achieving orbit and following return to Earth. Little is known, however, about the role vestibular information plays in the coordination of eye, head, and hand movements. Therefore, the first objective of this study is

to investigate the role vestibular information plays in the formulation of goal-directed eye and hand localization of targets.

The second objective of this study is to determine if adaptive alterations in eye-head coordination produce commensurate alterations in the ability to manually locate target positions; and conversely, if adaptive modification in eye-hand coordination transfers to the eye-head system. This investigation will help elucidate the basic mechanisms underlying the spatial programming of coordinated eye, head, and hand movements along with their adaptive properties.

Subjects will be seated on a rotatable chair for presentation of whole-body, passive rotation. Following termination of a transient rotational displacement, in darkness, they will be asked to point and generate eye movements towards the position of a previously seen stationary Earth-fixed target; the errors between the perceived and true target positions will be recorded. These tests will then

be repeated following exposure to stimuli which cause various combinations of visual, vestibular, and proprioceptive conflict. Post-adaptation test results will help determine the adaptive transfer characteristics between the eye-head and eye-hand systems based on observed errors in manual and ocular localization of the stationary target.

Developing a basic scientific understanding of the underlying mechanisms involved in the adaptation process will aid in the identification and testing of countermeasures that will reduce or eliminate the risk associated with these neural adaptive changes. A countermeasure which can readapt one system may actually help readapt all of these sensorimotor systems. Conversely, it may be that each system needs its own readaptation countermeasure.

### **Measurement of Gaze, Head, and Arm Motion**

The angle of gaze (angular eye position with respect to space) and head rotation will be obtained directly using the magnetic field/scleral search coil technique with a 6-ft<sup>3</sup> field coil system (CNC Engineering, Seattle, WA). This system basically works as follows. A rotating magnetic vector is established about the subject using *field coils* driven by an oscillator. The subject wears a contact lens (sclastic annulus) with a very fine copper wire embedded in it. The alternating magnetic field induces a minute current within this *search coil*. The phase of the signal induced in the search coil is compared with the phase of the signal induced in a stationary *reference coil* using special phase-detector amplifiers. The resulting phase difference indicates the angle of the coil (and thus, the angle of the eye) in space. A similar coil may be attached to the head to measure angular head position.

A video-based motion analyzing system (Motion Analysis Corporation, Santa Rosa, CA) will be used to measure and analyze arm movement during manual target localization. This system has the capability of tracking passive reflective or active markers placed on the body and analyzing their interrelationships producing a three-dimensional biomechanical assessment of body movement. In the present experiments, the pointing response will be recorded by placing infrared light emitting diode (LED) markers on the shoulder and index finger. The LED marker trajectories produced by the arm and finger will be recorded with video cameras. The video image from each of the cameras is fed into a video processor where the outline edges of the markers are extracted and passed to the system's host computer for analysis.

The Motion Analysis System will provide, among other things, the angle in the horizontal plane between a zero-degree reference line and the line connecting the finger and shoulder markers. This angle will provide our measure of pointing direction.

### **FY91 ACCOMPLISHMENTS**

- The magnetic field scleral search coil system used to record eye and head movements is operational and integrated with the video-based motion analysis system.
- The Research and Technology Objectives and Plans Program proposal has been reviewed and was selected to be part of the Life Sciences Biomedical Research Program.

## PLANNED FUTURE WORK

These experiments will provide initial investigations of the possible interactions between various sensory-motor systems when one or more of these systems has been altered. In the future, we hope to expand these studies to include similar experiments involving *active* (subject initiated) head motion, as active head rotation and displacement due to locomotion are more natural activities. Also, all of the head motion we will use in the proposed experiments will be in the horizontal plane. We eventually hope to expand these studies to investigate the possible exchange of information between different sensory-motor systems in response to *vertical* or *pitch* motion.

To better appreciate the effects of adaptation to altered sensory stimuli, we also plan to extend existing mathematical models relating

target and head motion with measured eye rotation to account for the observed adaptation effects. This will eventually include modifications to describe the effects of *active* head rotation, the distributed effects of both far and near visual targets, and the possible influence of the otoliths in both translational and *rotational* motion. Such a model could then be used to provide *what if ...?* simulations that will help direct future experimental inquiries.

Future plans include extending the results of this study towards developing in-flight eye-head-hand coordination studies.

**TITLE OF INVESTIGATION:** Solid Phase Enzyme Partitioning for Liquid Waste Recycling

**PROJECT MANAGER:** Glenn Spaulding, M.D./SD4/(713) 483-2357

FUNDING	FY90	FY91	FY92
In-House:	\$0	\$25k	\$0
Total funds:	\$0	\$25k	\$0

**OBJECTIVE AND APPROACH**

The objective of this feasibility study was to immobilize enzymes to a solid phase for the degradation of specific low molecular weight species that are not removed by current water reclamation processes. An example of a class of difficult-to-claim species on Space Station Freedom would be the low molecular alcohols. This study chose propanol as a test species. An enzyme, alcohol dehydrogenase, was covalently coupled to a porous membrane. A solution containing 2-propanol was cycled across the membrane and through a diode array spectrophotometer. Adsorption was monitored at 295 nm for the acetone byproduct and at 208 nm for protein leaching. Alpha-NADP and beta-NADP analogs were utilized to modulate the degradation process through competitive inhibition.

**FY91 ACCOMPLISHMENTS**

The enzyme alcohol dehydrogenase was successfully covalently coupled to a solid-phase partition. Converting 2-propanol to acetone was specific and could be competitively inhibited by mixing alpha- and beta-NADP analogs; the effectiveness increased with the sole addition of the alpha-NADP analog

(fig. 24). Secondary leaching was monitored at 208 nm and minimal leaching was observed. The data indicates that specific contaminated water can be removed from polished water utilizing cost-effective enzymatic reduction techniques.

**PLANNED FUTURE WORK**

The information, results, and technologies have been presented to the Johnson Space Reclamation Group for evaluation and incorporation into current models and polishing strategies

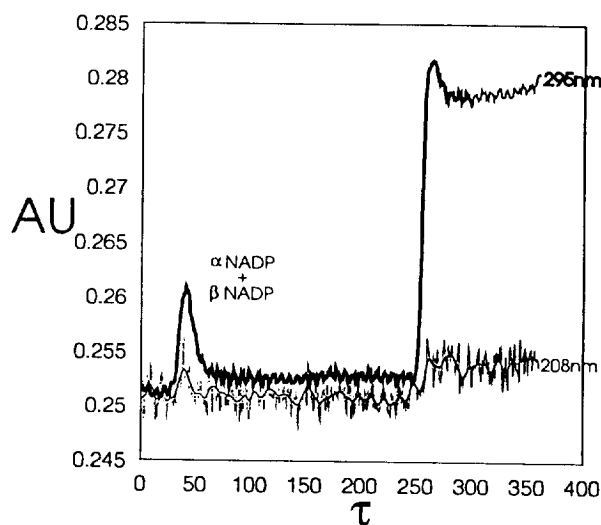

Figure 24.- 2-propanol to acetone.

---

---

**TITLE OF INVESTIGATION:** B Cell Radiosensitivity and Protection by Cytokines

**PROJECT MANAGER:** Peggy Whitson, Ph.D/SD4/(713) 483-7046

<b>FUNDING:</b>	<b>FY90</b>	<b>FY91</b>	<b>FY92</b>
In-house:	\$0	\$35k	\$25
Contractors:	0	0	0
Grants:	0	0	0
Total funds:	\$0	\$35k	\$25

---

---

## OBJECTIVE AND APPROACH

A number of naturally occurring hormones termed cytokines have been shown to be capable of protecting lymphocytes from ionizing radiation under both *in vivo* and *in vitro* conditions. This property is believed to be due to the ability of these agents to reduce the transition time from a radiosensitive quiescent ( $G_0$ ) state to a less radiosensitive activated ( $G_1$ ) state. Mature bone-marrow-derived lymphocytes, or B cells, circulate throughout the vascular system in a quiescent state exhibiting a relatively high radiosensitivity to ionizing radiation. Because B cells are solely responsible for the production of antibodies, and, as such, are indispensable for human survival, their radiosensitivity (particularly during long-duration space flights) could lead to immune suppression which, in turn, could severely limit the mission goals or threaten crewmembers' lives. It was hypothesized that the well-characterized inhibitory effects of sublethal (low dose) radiation on B-cell activation by antigenic or mitogenic stimuli damaged specific radiosensitive sites in the lymphocyte activation cascade. This inherent radiosensitivity of one or more activation events would then be responsible for precluding lymphocyte entry into the cell

cycle and subsequent differentiation into antibody-producing cells. This project is now in the process of identifying the activation event(s) that are radiosensitive and, thus, most likely to be involved in the differential radiosensitivity between quiescent and activated B lymphocytes. It was further hypothesized that pretreatment of B lymphocytes with specific *permissive* cytokines abrogates or significantly reduces B cell radiosensitivity. To perform these studies, purified human peripheral B cells are gamma-irradiated at the University of Texas Medical Branch (UTMB) and analyzed at the Johnson Space Center using both tissue culture and molecular biology techniques and equipment.

## FY91 ACCOMPLISHMENTS

### Effect of Surface Ig Expression on B Cell Radiosensitivity

Riggs and coworkers (ref. 1) have shown that B cells bearing a high-surface immunoglobulin M (sIgM):sIgD ratio were more radiosensitive than B cells bearing a low sIgM:sIgD ratio. Did functionally defined B lymphocytes show different radiosensitivities if they were irradiated *in vitro*? The initial approach to this question

was to irradiate an Epstein-Barr transformed (EBV)-human B cell line (termed CESS) that expressed surface IgG (i.e., sIg<sup>+</sup>). This strategy, although not addressing directly the relative radiosensitivities of sIgM/sIgD-bearing B cells, would enable the program team to develop the technical expertise of isolating subpopulations of specific sIg-bearing cells and to ask a more basic question related to the radiosensitivity of cells expressing a single Ig isotype. Using a *panning* technique, sIg-rich CESS and sIg-poor CESS cell fractions were obtained that contained approximately 80 and 20 percent of IgG-bearing cells, respectively, when measured by direct flow cytometry (FCM) with fluorescently conjugated anti-IgG.

To measure CESS cell radiosensitivity, a soft-agar cloning assay was established as described (ref. 2). Briefly, both nonirradiated CESS test cells and irradiated CESS feeder cells (2000 rad <sup>137</sup>Cs delivered at 80 rad/min at room temperature) were seeded into media containing 0.3 percent agar and aliquoted into six well plates. Each well contained 3150 nonirradiated test cells and 10<sup>5</sup> irradiated CESS feeder cells. The cultures had been incubated for 14 days when colonies of 50 cells or greater were counted. Colony-forming efficiency (CFE) was  $2.4 \pm 0.9$  percent (mean  $\pm$  SD, N=3). More recently, it was discovered that irradiated feeder cells could be replaced by CESS conditioned medium without significantly changing the CFE. The results reported below were obtained from this system. While the results reported here (fig. 25) are preliminary, the data obtained thus far from two separate trials (i.e., 83 and 78 percent sIg<sup>+</sup> vs 27 and 14 percent sIg<sup>+</sup> sIg-poor) suggest that differences in the surface expression of IgG in EBV-transformed B cells do not significantly affect cell radiosensitivity.

While these preliminary studies have focused on a continuously cycling cell line, they do

demonstrate the ability to quantitate lymphocyte subpopulations using fluorescent antibodies and FCM. Bromodeoxyuridine (BrdU)/anti-BrdU has also been used to determine CESS cell cycling, and this technique will continue to be used to determine B cell cycling in response to gamma irradiation and cytokines. Finally, these studies have enabled us to gain experience in using the [<sup>137</sup>Cs] irradiator at UTMB in Galveston and have given the team as well, the opportunity to work closely with Dr. Ullrich, the director of this facility.

## B Cell Activation

Depending upon the particular reagent or reagent combination used, resting B cells can be activated either into G<sub>1</sub> phase or all the way into S phase and beyond (i.e., proliferation as well as differentiation and antibody secretion). To test the ability of various activation agents on B cells, lymphocytes were obtained from a healthy human volunteer and isolated using Ficoll/Hypaque (Pharmacia). The B cells were further purified using Lympho-Kwik (One Lambda, Inc., Los Angeles, CA). Using FCM, the final B cell preparation routinely was found to contain 80 percent CD 20<sup>+</sup> (B cells); 20 percent CD4<sup>+</sup> (T cells); and < 0.1 percent monocytes (Leukogate; Becton-Dickinson, Menlo Park, CA). Purified B cells were then incubated for 70 hours in the presence of anti-IgM, anti-IgM/ cytochalasin B(CB), anti-IgM/TPA (phorbol ester), and *S. aureus* Cowans I (SAC). After incubation for 72 hours, tetrazolium salt (MTT) was added during the final 2 hours of the assay. Results (see fig. 26) demonstrate that MTT conversion was significantly enhanced by each of the test reagents, indicating that each of these reagents was successful in activating B lymphocytes. Moreover, the magnitude of formazan product detected was as expected from those reagents

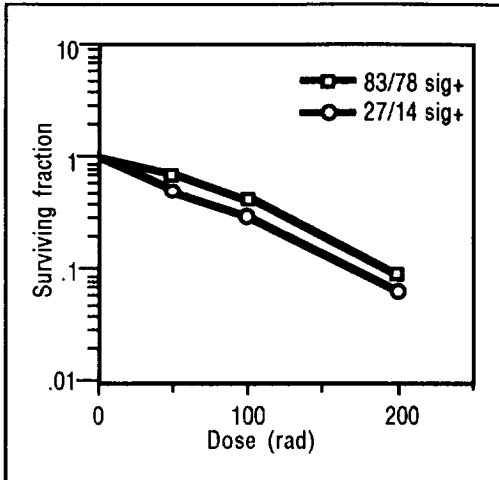

Figure 25.— Effect of sig expression on CESS radiosensitivity.

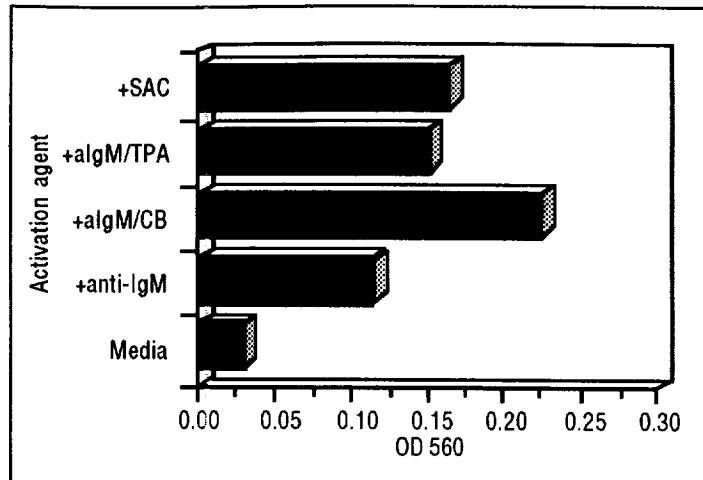

Figure 26.— B cell activating agents.

known to promote B cells to cycle into the S phase (i.e., TPA, CB, and SAC). These preliminary studies have provided an experimental foundation for the initiation of our proposed studies on protein kinase C (PKC) radiosensitivity.

### PLANNED FUTURE WORK

A Research and Technology Objectives and Plans procedure entitled “B cell radiosensitivity and protection by cytokines” was submitted on October 12, 1991, to the NASA Radiation Health Program. Review of this proposal should be completed by December 1991. During the coming year, all efforts will be directed toward identification of radiosensitive events in the B cell activation cascade beginning with PKC. Previous studies have demonstrated that stimulation of B cells through surface immunoglobulin results in the activation of PKC, suggesting that PKC may participate in the initial activation of B cells by antigen. This, together with the finding that PKC mRNA levels are elevated in Syrian hamster embryo cells by as much as 2.3 fold by 25 cGy gamma radiation, indicates that PKC radiosensitivity in B cell

activation may contribute to the differential radiosensitivity between quiescent and activated B lymphocytes. The project team intends to determine whether B cell PKC activity or PKC mRNA levels exhibit radiosensitivity to low-dose gamma radiation. To answer this question, purified B cells will be exposed at room temperature to a predetermined dose/dose-rate of  $^{137}\text{Cs}$  (i.e., a dose/dose-rate sufficient to significantly reduce anti-IgM activation events), then activated 2 hours later with anti-IgM-sepharose. Poly A<sup>+</sup> mRNA will then be isolated and probed using a labeled 1.7-kilobase human PKC beta fragment. Relative mRNA levels between control and irradiated/activated cells will then be determined by densitometric analysis of the resulting Northern blots. In conjunction with the PKC mRNA studies, cellular PKC enzyme levels will be determined by Western blot using polyclonal anti-PKC (Oncogene Science, Manhasset, NY). Later studies on B cell activation events will then be initiated with respect to F-actin levels, and with respect to protein-tyrosine kinase activation — both important events in the antigen-directed activation of human B cells.



## REFERENCES

1. Riggs, J. E.; Lussier, A. M.; Lee, S. K.; Appel, M. C.; and Woodland, R. T.: Differential radiosensitivity among B cell subpopulations. *J. Immunol.*, vol. 141:1988, pp. 1799-1807.
2. Bouck, N.; and DiMayorca, G.: Evaluation of chemical carcinogenicity by *in vitro* neoplastic transformation. *Methods in Enzymology*. (W. B. Jakoby and I. H. Pastan) Academic Press, Inc. New York, 1979, pp. 299-300.

---

---

**TITLE OF INVESTIGATION:** Adaptive Control of a Robot Arm Using an Artificial Neural Net With Stereo Vision Input

**PROJECT MANAGER:** Timothy F. Cleghorn, Ph.D./PT41/(713) 483-8090

<b>FUNDING:</b>	<b>FY90</b>	<b>(projected)</b>	
		<b>FY91</b>	<b>FY92</b>
In-house	\$0	\$16k	\$0
Contractor:	50k	44k	60k
Total funds:	\$50k	\$60k	\$60k

---

---

### **OBJECTIVES AND APPROACH**

As NASA prepares to move into the Space Station era in the late 1990's and beyond, it is becoming clear that some major space activities must be performed by unsupervised robots operating in autonomous modes. There are several types of tasks for which this approach can prove highly effective. Autonomous robots can perform tasks in locations which are not readily accessible to manned vehicles, such as polar or geosynchronous orbits. In addition, the robots can perform hazardous tasks to which extravehicular activity (EVA) astronauts should not be exposed. The robots can also perform highly repetitive tasks, thus freeing astronauts for more productive work. Finally, robots are not subject to the limitations of humans, particularly from the standpoints of endurance and rapid EVA availability.

The overall objectives of this project are to develop, for NASA, the technologies needed to perform autonomous robotics space operations, and to ensure their availability at the Johnson Space Center. In order to demonstrate the potential uses of artificial neural

net technology with respect to robotic space operations, a commercially developed robot demonstration system is being enhanced and will ultimately include capabilities such as collision avoidance and grasping of moving target objects. This system, developed by Dr. Michael Kuperstein, president of Symbus Technologies, Inc. of Brookline, Massachusetts, originally consisted of a MICROBOT robot arm which used stereo camera input to an adaptive neural network to *learn* to grasp a cylindrical target object. Unlike other artificial neural nets, this system does not map out its 3-dimensional environment, but rather it associates the camera images with the robot actuator drive positions, much as a human baby learns eye-to-hand coordination. A graphics simulation has been built, which permits progressively more complex behaviors to be modeled.

### **FY91 ACCOMPLISHMENTS**

At the end of FY91, an enhanced simulation, plus source code, was delivered to the Johnson Space Center. This simulation, which

runs on a Silicon Graphics computer, illustrates a Robotics Research Corp. K-1607 7-DOF arm learning to grasp either a cylinder or a sphere. The accuracy of the grasp has been improved over that of the FY90 version, which also could grasp only a spherical target. Also included in the FY91 version of the program are left and right camera views, as well as the global views of the arm, camera setup, and target.

### PLANNED FUTURE WORK

The work planned for FY92 consists of incorporating a single major enhancement into the simulation. Specifically, the arm will learn to grasp a moving target object. In addition, funding from other sources will be sought (Research and Technology Objectives and Plans Program) for the addition of force

feedback. This will allow obstacle avoidance to be included in the system. The ultimate goal is to have moving targets and obstacles, and to port this system to a real hardware environment.

### REFERENCE DOCUMENTS

1. Kuperstein, M.: Adaptive Visual-Motor Coordination in Multijoint Robots Using Parallel Architecture. Proceedings from IEEE International Conference on Automation & Robotics, Raleigh, NC, 1987, pp. 1595-1602.
2. Kuperstein, M.; and Rubenstein, J.: Implementation of an Adaptive Neural Controller for Sensory-Motor Coordination. *IEEE Control Systems Magazine*, April 1989, pp. 25-30.

---

---

**TITLE OF INVESTIGATION:** Distributed Artificial Intelligence-Based Schedule Assessment for Space Shuttle Flight Software Production

**PROJECT MANAGER:** John F. Muratore/DP/(713) 483-0796

<b>FUNDING:</b>	<b>FY90</b>	<b>FY91</b>	<b>FY92</b>	<b>Total</b>
Funding	\$40k	\$40k	\$0	\$80k
Cost	13k	27k	0	40k
Carryover	\$27k	\$0	\$0	\$0

---

---

## OBJECTIVES

The objective of this project is to develop a tool to assist the Mission Operations Directorate Reconfiguration Management Division (DP) in the coordination of the many schedule details involved in the production of flight software. The development of multiple options for evaluation is required. The goal of this project is the effective application of new technology to the flight software reconfiguration scheduling process. This local workstation system shall have the capability to perform *what-if* options for evaluation using a combination of conventional and artificial intelligence-based tools. The final results will be communicated electronically back to the mainframe-based scheduler. These capabilities shall enhance the flight software production process by providing multiple options for evaluation. Quality improvements are expected in the generation of better scheduling, planning, and resource utilization of the flight software production process, including the integration of multimission planning. The use of a local workstation will allow a faster response to changes and earlier identification

of schedule problems, thus, allowing more time to work resource problems, which will become more critical as the flight rate increases.

## ACCOMPLISHMENTS IN FY90

The prototype system was successfully electronically interfaced with the mainframe scheduling system. Two workstations were updated with hardware/software in order to implement a *full up* integrated system with graphics support. This system is currently being used to conduct schedule evaluations. The use of this system has resulted in a manpower savings of five people that would otherwise be required for flight software production schedule assessments.

## PLANNED FUTURE WORK

This organization is committed to the continued utilization of artificial intelligence-based schedule assessment techniques for space flight software production. The success of this

project has supported the seed requirements for future Research and Technology Objectives and Plans proposals.

#### **EXPECTED COMPLETION DATE**

The current scope of this project has been completed.

---

---

**TITLE OF INVESTIGATION:** Virtual Environments for Training

**PROJECT MANAGER:** Robert T. Savely/PT4/Software Technology Branch  
(713) 483-8105

FUNDING:	FY89	FY90	FY91	(Projected)	
				FY92	FY93
In-house:	\$0	\$0	\$74k	\$67k	\$50k
Contractors:	0	0	0	0	0
Grants:	0	0	0	0	0
Total funds:	\$0	\$0	\$74k	\$67k	\$50k

---

---

## OBJECTIVE AND APPROACH

This investigation is a joint project between the Space Station Training Office (DT) and the Software Technology Branch (PT4).

Training is a major cost element for existing and future NASA operations. Virtual environment technology may provide alternatives to physical simulators (especially for part-task training) and avoid their high initial and maintenance costs. The integration of the Johnson Space Center's (JSC's) intelligent computer-aided training (ICAT) technology with virtual environment technology will permit ICAT systems to address a larger variety of training tasks with the potential for unprecedented realism for the visual, auditory, and tactile senses. In addition to the integration of ICAT technology with virtual environment technology, this project will compare a virtual environment approach to Space Station cupola training with projection dome and pancake window approaches. Ultimately, the project team intends to produce an ICAT application for a suitable Space Shuttle or Space Station training task.

Finally, this project will explore the long-distance networking of virtual environment systems for data visualization and engineering design applications.

As an ancillary to the project, technology requirements to drive virtual environment research and development will be determined.

## FY91 ACCOMPLISHMENTS

- JSC Director's Discretionary Funds were used to procure a VPL Research, Inc., EyePhone/DataGlove System and secure training for two software developers.
- Delivery of the VPL Research System was made in the latter part of September 1991 (fig. 27).
- A simple Space Station Freedom cupola model was developed during the training session attended by the JSC software developers.
- The virtual environment system was integrated with graphics computers and became operational on October 18, 1991.

Figure 27.— Bebe Ly of the Information Systems Directorate's Software Technology Branch demonstrates the VPL research equipment.

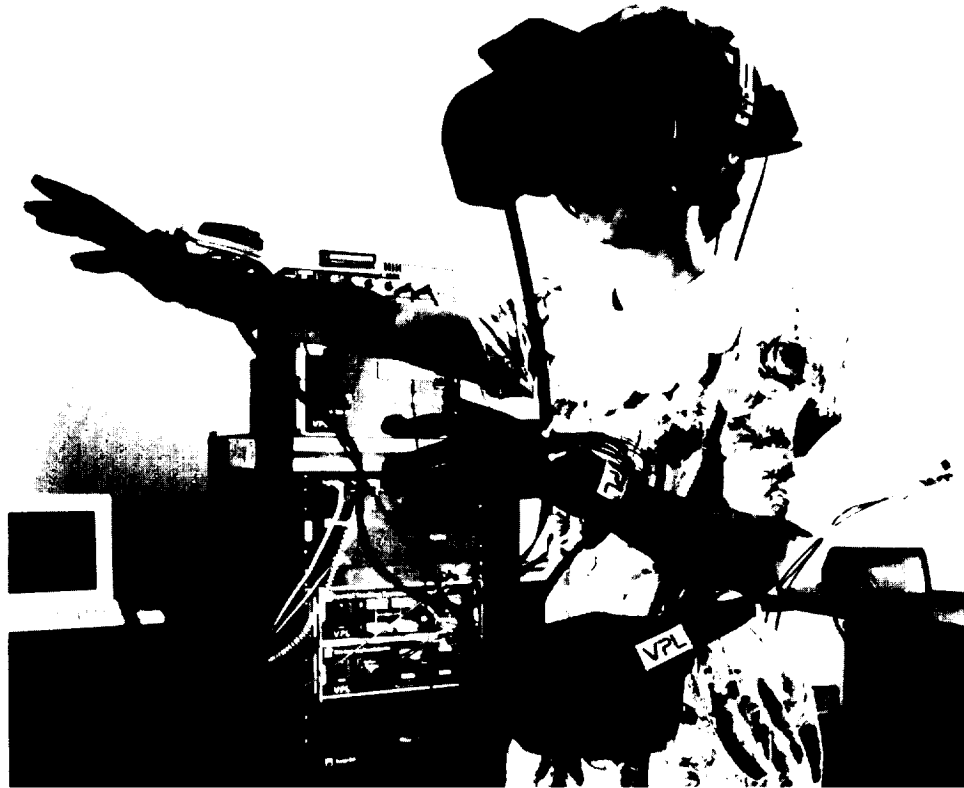

#### PLANNED FUTURE WORK

- Complete comparative study on cupola training with the Space Station Training Office.
- Select, in cooperation with the Space Station Training Office, a suitable candidate for an ICAT application that utilizes the virtual environment technology and begin development of that application.
- Upgrade the virtual environment system to support higher resolution graphics, digitized images, and video.
- Initiate, in cooperation with the Marshall Space Flight Center, a network demonstration of the long-distance sharing of a single virtual environment by two or more individuals; the probable application will be engineering reviews of Space Station Freedom models.
- Work cooperatively with the Robotic Applications Labs (ER42) to utilize JSC graphics development software.
- Integrate digitized images and videos with graphics to provide greater realism and shorten development time.
- Evaluate commercially available systems for tactile and force feedback.
- Identify technology needs to enhance the ability of virtual environment technology to support future training requirements.

---

---

**TITLE OF INVESTIGATION:** Optical Analysis Systems

**PROJECT MANAGER:** John Mulholland/RA/FTS 572-5516

<b>FUNDING:</b>	<b>FY89</b>	<b>FY91</b>	<b>FY92</b>
	\$40k	\$50k	\$65k

---

---

### **OBJECTIVE AND APPROACH**

The objective of this project was to develop self-contained, portable test equipment and procedures for rapid response testing and evaluation of space-related critical components. The specific need for this type of system became apparent during the STS-26 dynatube leak anomaly investigation. There were no *in-place* techniques to nonintrusively determine stresses, strains, torque, cracks, etc., on this component while installed in the vehicle. There are many Space Shuttle and Space Station Freedom systems where limited physical access also prohibits the use of traditional test methods such as ultrasonics and X ray. This project was designed to provide holographic test apparatus capable of accessing and providing quantitative failure analysis on components in restrictive areas.

### **FY91 ACCOMPLISHMENTS**

The final interferometer and software system was completed this year. The software system provides automatic quantitative deformation measurements with accompanying wire-frame displacement plots. A test matrix to determine the applicability of using holographic methods to determine cracks in structures was completed this year. The results revealed that holographic test methods are a very attractive

analysis option, capable of providing a real-time, whole-field view of large structural areas. Figure 28 shows a typical hologram view of a flat structure with four machined cracks heated with a test lamp. The flaws are obvious with the typical bull's-eye stress concentration pattern around the flaw area. Figure 29 is a phase map and wire-frame plot of the previous hologram showing the actual displacement field. An additional test matrix was conducted in support of the hard upper torso shell disbond analysis test project. The preliminary results of this test matrix show holography capable of detecting flaws in composite materials.

### **PLANNED FUTURE WORK**

Vehicle health monitoring and nondestructive evaluation has been determined to be a high-priority Agency need. Holographic test methods have proven to be a very effective nondestructive analysis tool. A second presentation to NASA Headquarters, in early FY92, is scheduled to discuss the possibility of using holographic methods to structurally analyze the new Shuttle turbopumps and to investigate primary reaction control subsystem engine combustion instability. Additionally, a Research and Technology Objectives and Plans proposal is being coordinated with the NASA-Johnson Space Center's (JSC's)



Structures and Mechanics Division to provide structural analysis on the White Sands Test Facility fleet leader vehicles. Working in conjunction with JSC, Texas A&M will be

contracted to provide the computer codes for a project that could lead to a very attractive aging aircraft analysis package.

Figure 28.- Hologram of flat structure showing four evident cracks.



Hologram of Flat Structure Showing Four Evident Cracks

Figure 29.- Phase map/wire-frame plot of cracked structure.

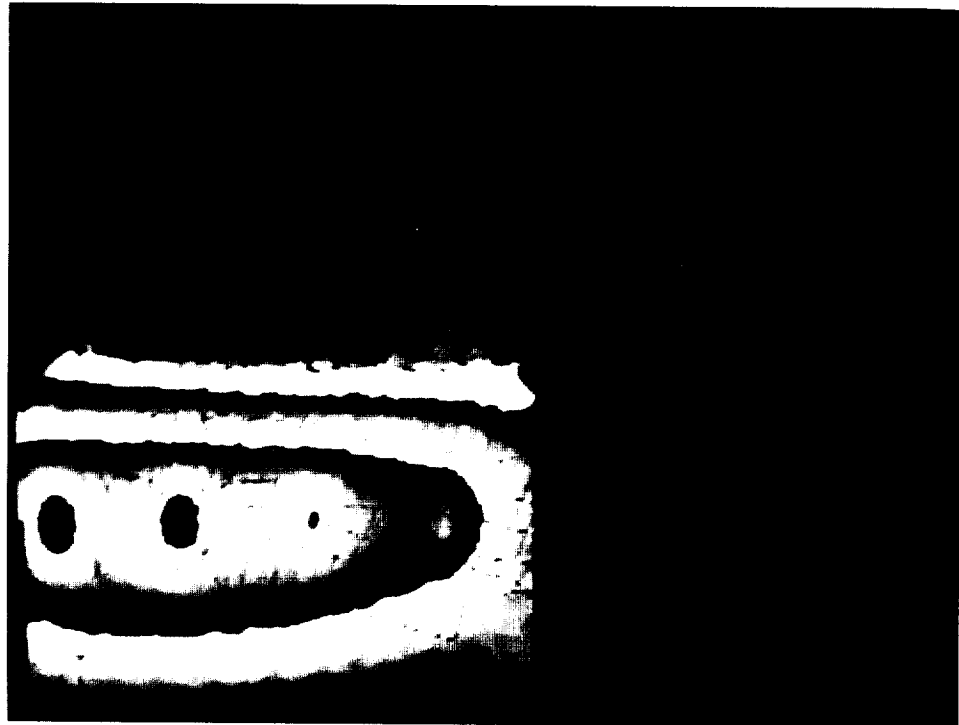

Phase Map/Wire Frame Plot of Cracked Structure

---

---

**TITLE OF INVESTIGATION:** Diluent Gas Studies in High-Pressure Oxygen Systems

**PROJECT MANAGER:** Radel Bunker/RA/FTS 572-5733

<b>FUNDING:</b>	<b>Total Prior Years</b>	<b>(Projected)</b>	
		<b>FY91</b>	<b>FY92</b>
In-house	\$100k	\$15k	
KSC			~\$15k

---

---

## OBJECTIVE AND APPROACH

Life support systems designed for Space Shuttle and Space Station Freedom will use non-metallic materials in high-pressure oxygen systems. When exposed to ignition sources, most nonmetals ignite and burn in oxygen environments (ref. 1). Burning nonmetals in high-pressure oxygen systems could cause catastrophic system failures. Adding small quantities of nontoxic gases to oxygen might prevent burning of nonmetals in the high-pressure oxygen systems. The objective of this project was to determine if a physiologically acceptable diluent gas can be added to oxygen to significantly reduce the ignition or combustion of nonmetals.

To determine the effect of diluents on combustion of nonmetals, downward-flame propagation flammability tests were conducted on test samples using diluent/oxygen mixtures with various diluent concentrations. The test logic was to determine the minimum diluent concentration in a diluent/oxygen mixture required for sample self-extinguishment at 1000, 3000, and 5000 psia.

Helium, nitrogen, argon, and neon were the diluent gases used during testing. Three

nonmetals, which are used extensively in high-pressure oxygen systems, were used in this evaluation: Teflon PTFE, Kelf 81, and Viton.

## FY91 ACCOMPLISHMENTS

Tests were conducted at 1000 psia on Teflon PTFE using neon diluent. The tests were conducted in a cylindrical stainless steel chamber fitted with a copper liner (fig. 30). The results indicated that at this pressure, neon was as effective as nitrogen for preventing flame propagation on Teflon PTFE. Comprehensive results for tests at 1000 and 3000 psia are presented in figures 31, 32, and 33. Tests conducted at 5000 psia on Teflon PTFE and Kel-F 81, using nitrogen diluent, resulted in complete combustion of samples in environments of 19 percent oxygen/81 percent nitrogen.

The data indicates that at pressures of 1000 psia and higher, the most commonly used nonmetals in oxygen systems would burn, even in environments having low oxygen concentrations. Small quantities of diluents were ineffective in preventing flame propagation of nonmetals. Large quantities of diluents, approximately 60 percent and higher,

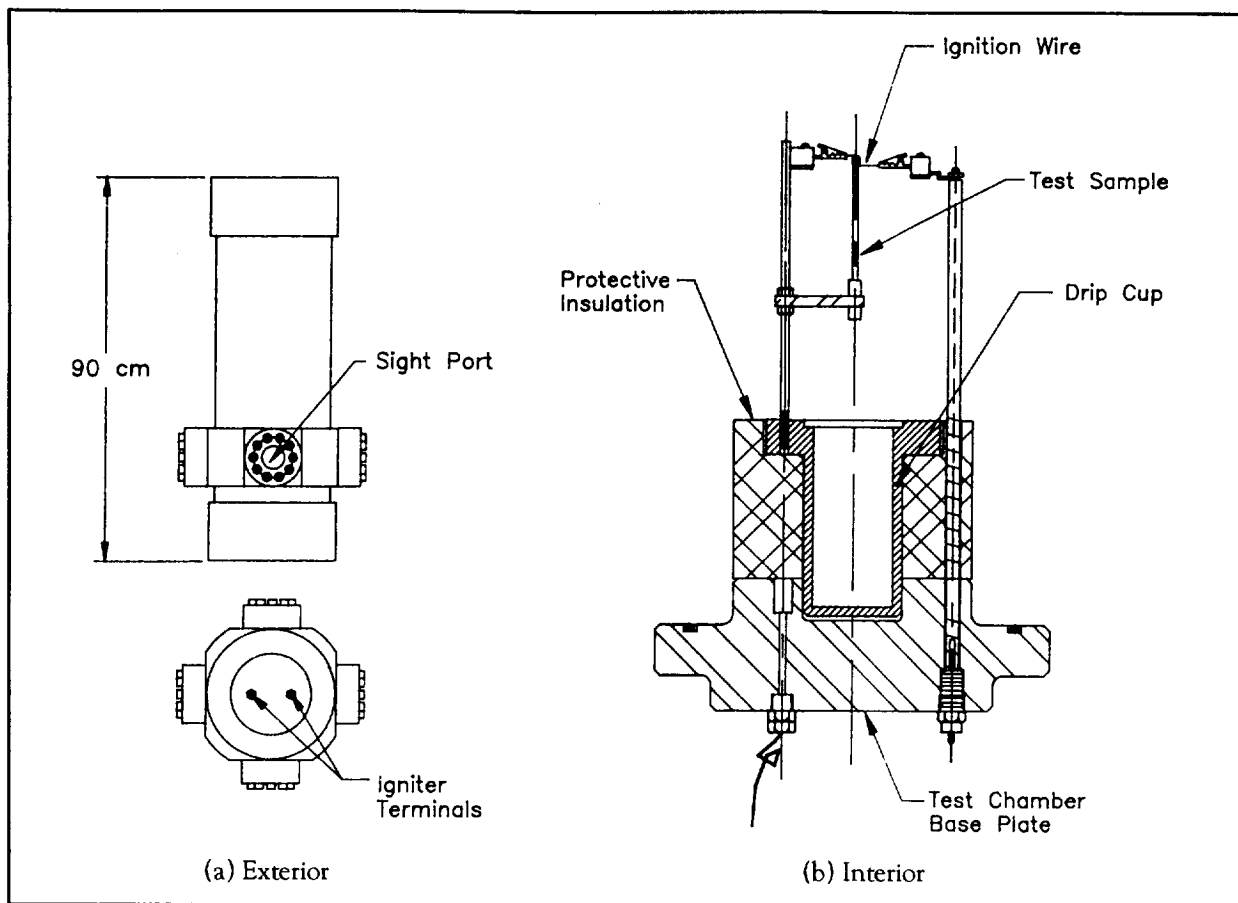

Figure 30.— Schematic of test chamber.

were required to prevent flame propagation. Helium was the most effective diluent for preventing flame propagation, following nitrogen, neon, and argon. The effectiveness of helium could be explained by its thermal conductivity, which could have resulted in reduced heat feedback to the burning material.

The differences between the diluents regarding their effectiveness for preventing flame propagation decreased with increasing pressures. This phenomenon might be explained in part by the pressure effects on thermal conductivity.

Nonmetals considered nonflammable in air at ambient pressures could ignite and burn in air pressure greater than 3000 psia, indicating

that high-pressure air systems require safety precautions and should not be treated as high-pressure nitrogen systems. Based on these results, high-pressure air systems above 3000 psia need to be evaluated and treated as high-pressure oxygen systems from the standpoint of propagation of combustion after ignition. Other material currently used for high-pressure air systems should be evaluated for ignition and combustion propagation. Based on the results from the high-pressure tests, helium should be tested at low pressures to evaluate for possible fire extinguishment applications.

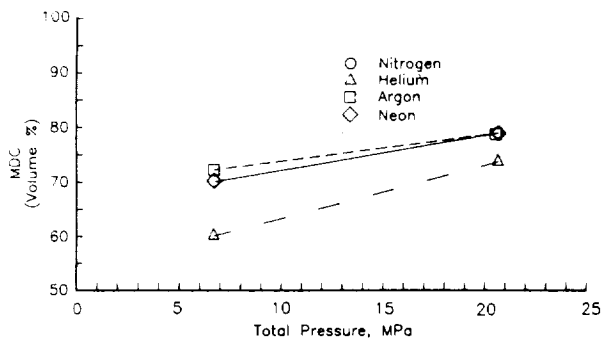

Figure 31.— Minimum diluent concentration (MDC) in diluent/oxygen mixtures required for Teflon PTFE self-extinguishment.

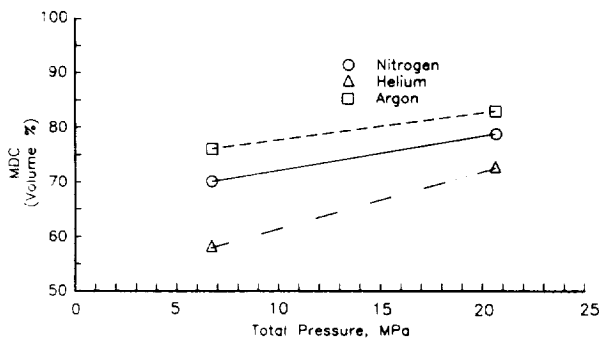

Figure 32.— MDC in diluent/oxygen mixtures required for KEL-F 81 self-extinguishment.

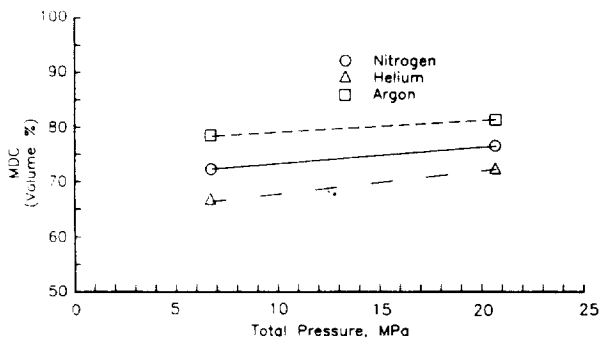

Figure 33.— MDC in diluent/oxygen mixtures required for Viton self-extinguishment.

## PLANNED FUTURE WORK

The results from this program will be summarized and submitted in a paper to a fire science journal. The project was completed in FY91. The John F. Kennedy Space Center is currently defining a test series to look at high-pressure air systems.

## REFERENCE DOCUMENTS

1. Hirsch, D. B.; Bunker, R. L.; Janoff, D.: "Effects of Oxygen Concentration, Diluents, and Pressure on Ignition and Flame Spread Rates of Nonmetals: A Review Paper." *Flammability and Sensitivity of Materials in Oxygen-Enriched Atmospheres*. Stoltzfus, J. M.; and McIlroy, K. eds., vol. 5, ASTM STP 1111, American Society for Testing and Materials, Philadelphia, 1991.

---

---

**TITLE OF INVESTIGATION:** Development of Alloys with Improved Burn-Resistance

**PROJECT MANAGER:** Joel Stoltzfus/RA/FTS 572-5731

<b>FUNDING:</b>	<b>Total prior years</b>	<b>FY92</b>
In-house	\$90k	\$0
Other sources	180k	55k
Total funds	\$270k	\$55k

---

---

## **OBJECTIVE AND APPROACH**

The selection of burn-resistant metal alloys for use in oxygen systems has long been an important issue for designers of ground support and flight systems. Fires in oxygen systems are usually catastrophic and may result in loss of hardware and human life. Recent advances in the testing methodology have led to the ability to rank metals and alloys with respect to their flammability in oxygen. However, the alloys that have the greatest resistance to burning do not always have the best mechanical and physical properties. This has led to the need to develop new alloys with improved burn-resistance and more favorable mechanical and physical properties. The objective of this project is to develop the technology to formulate and test alloys with these advanced properties. This includes the capability of designing, making, forming, and performing flammability tests on the alloys. The flammability test results will be fed back into the design stage to improve the required properties and obtain the desired end product. This iterative loop will be repeated as required.

## **FY91 ACCOMPLISHMENTS**

Equipment for making the alloys and for producing test specimens has been installed and achieved. This includes a vacuum arc melting furnace for making the alloys (fig. 34) and a swaging machine for forming the test specimens (fig. 35). A series of 25 pure metals has been purchased.

Several pure metals, binary alloys, and commercial alloys have been tested. These tests are being conducted to understand the basic combustion properties so that an informed alloy design process may be accomplished. The interaction of alloying elements in commercial alloys also provides significant information to the data base on the ignition and combustion of metals and alloys. The minimum oxygen pressure required to support combustion of a 1/8-in. diameter cylindrical rod of pure metals is listed in table 3.

Commercially available titanium-, nickel-, base, and iron-based alloys have also been tested in the past year. To date, all of the commercially available titanium-based alloys show poor burn resistance. Nickel-based alloys, however, show a great deal of promise.



Figure 34.— Vacuum arc-melting furnace for making new alloys.



Figure 35.— Swaging machine for forming test specimens.

Table 2.— Threshold Pressure for Combustion for Some Elements

Pure element (psi)	Threshold pressure
Tungsten	50
Vanadium	200
Zinc	800
Silicon	4000
Cobalt	>6000

Pure lead, pure tin, and a series of binary lead-tin alloys were tested this year. For a 1/8-in. diameter cylindrical rod, the threshold pressure for combustion of pure lead is ~ 750 psig, and that for pure tin is ~ 200 psig. In the binary alloys it has been observed that the addition of approximately 2 wt percent tin or more to pure lead causes the alloy to burn at ~ 200 psig. Ignition tests also indicate a very strong dependency on the composition of the alloys. A detailed analysis of the tests has been reported in reference 1.

Three nickel-base alloys were successfully prepared at the White Sands Test Facility

(WSTF). The purpose of making these alloys was to determine the maximum amount of aluminum additions that could be made to pure nickel before the nickel-based alloy becomes flammable. The alloys prepared are Ni-20 at percent Al (~10 wt percent Al), Ni-50 at percent Al (~30 wt percent Al), and Ni-80 at percent Al (~65 wt percent Al). These alloys were then tested for chemical composition, both for the purposes of verifying the chemical composition of the alloys attempted, and also to check the homogeneity of the alloys. Efforts are under way to prepare samples from these alloys for the purposes of making test specimens (fig. 36).

#### PLANNED FUTURE WORK

The Materials Processing Facility will be very active in the coming years and will be instrumental in the development of new burn-resistant alloys at WSTF. Efforts to understand the effect of alloying elements on the combustion properties of alloys will continue. This effort will continue to be approached, both from the fundamentals of the theories of alloying and property development, and also from the point of view of experimental

verifications. We will continue to focus on nickel-, iron-, aluminum- and titanium-based alloys. Also, new methods of alloy making and shaping will be examined to produce more exotic alloys. The results of these and all other future tests will be incorporated in a data base which will be accessed by various means, including artificial intelligence software. It is expected that this data and the relevant software will enable us to make appropriate decisions when designing burn-resistant alloys.

### EXPECTED COMPLETION DATE

The JSC Director's Discretionary Fund Program objective of implementing the Materials Processing Facility has been completed in FY91. Flammability testing and new alloy development will continue as supported by supplementary funding sources.

### REFERENCE DOCUMENTS

1. Sircar, S.; Stoltzfus, J. M.; and Gunaji, M. V.: The Relative Ignitability and Flammability of Lead-Tin Binary Alloys. *Flammability and Sensitivity of Materials in Oxygen Enriched Atmospheres*, vol. 5, ASTM STP 1111, J. Stoltzfus and K. McIlroy, eds., American Society for Testing and Materials, Philadelphia, 1991, pp. 260-269.

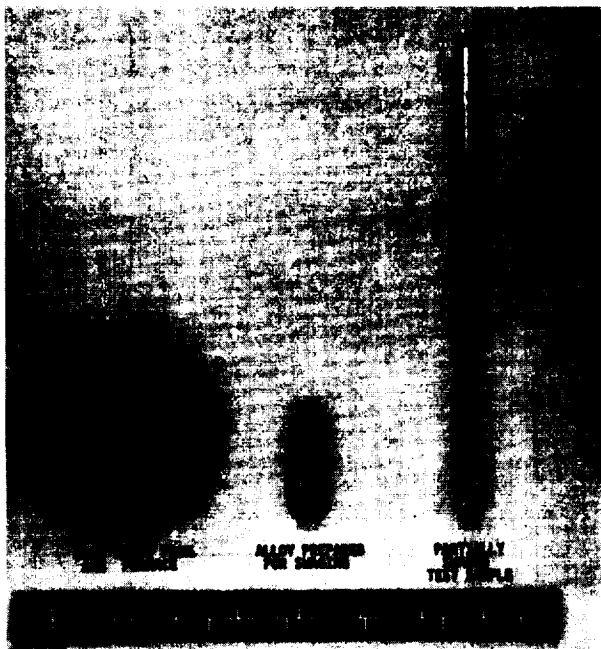

Figure 36.— Example of an alloy that has been cast and partially swaged.

**TITLE OF INVESTIGATION:** Evaluation of Pressurized Vessels Subject to Hypervelocity Particle Impact

**PROJECT MANAGER:** Michelle A. Rucker/RA/FTS 572-5730

FUNDING:	FY89	FY90	FY91	(Projected)	
				FY92	FY93
In-house	\$0	\$0	\$15k	\$80k	\$60k
Contractors:	0	0	0	50k	50k
Grants:	0	0	0	35k	70k
Total funds:	\$0	\$0	\$15k	\$165k	\$180k

**OBJECTIVE AND APPROACH**

The objective of this test program is to document the future modes of various types of pressure vessels following hypervelocity projectile impact (such as that occurring during an orbital debris collision). In particular, whether such vessels fragment or simply burst and relieve pressure will be useful to pressure system designers. Test articles of interest will include thin- and thick-walled vessels of various construction; vessels containing liquid, gas, or two-phase media; and vessels subject to various projectile impact angles. A two-stage, light gas gun will be used to simulate orbital debris impacts on pressurized test vessels; subsequent failures will be monitored using witness plates, high-speed cameras, and computer-enhanced motion analysis.

(MDPWG) meeting. Input from MDPWG members, McDonnell Douglas, and interested Marshall Space Flight Center (MSFC) and Lewis Research Center personnel was incorporated into the final test plan (ref. 1).

- A series of checkout tests, using empty stainless steel vessels, verified that the proposed test system and instrumentation were operating correctly.
- Glenn Ecord/ES5 arranged a meeting between White Sands Test Facility (WSTF) and TRW. TRW has agreed to provide all test articles needed for this program free-of-charge in exchange for access to test data.
- McDonnell Douglas (Huntington Beach) has expressed interest in this program and is actively seeking internal research and development funding for follow-on work.
- Jennifer Horn/ED52 (MSFC) is closely monitoring WSTF's progress and has

**FY91 ACCOMPLISHMENTS**

- The original JSC Director's Discretionary Fund proposal was presented at a Johnson Space Center Meteoroid and Debris Protection Working Group



encouraged Boeing/MSFC to review data for possible applications to Space Station hardware.

## PLANNED FUTURE WORK

The first shipment of TRW vessels is expected to arrive in early FY92. Bare aluminum shells and graphite-epoxy (Gr-Ep), overwrapped aluminum shells will be evaluated during Phase I testing. Multiple test article variations (different liner thicknesses, various coatings, glass-filled Gr-EP, etc.) will be provided by TRW as needed. Based on the results of the first 50 tests (scheduled to be completed by

mid-FY92), Phase II and Phase III test matrices will be developed. Results will be compiled into a data base and reported during monthly MDPWG meetings. A final report will be issued in FY93.

## REFERENCE DOCUMENTS

1. Rucker, M. A.; and Garcia, B.: Evaluation of Pressure Vessels Subject to Hypervelocity Projectile Impact. National Aeronautics and Space Administration, White Sands Test Facility, test plan no. TP-WSTF-668.

---

---

**TITLE OF INVESTIGATION:** Long-Term Material/Fuel Interactions Predicted by Microcalorimetry

**PROJECT MANAGER:** Radel Bunker/RA/FTS 572-5733

FUNDING:	FY91	(Projected)	
		FY92	FY93
In-house:\$30k	\$65k	\$55k	
Contractors:	0	0	0
Grants:	0	0	0
Total funds:	\$30k	\$65k	\$55k

---

---

## OBJECTIVE AND APPROACH

The objective of the proposed study is to determine if microcalorimetry can be used to predict long-term effects of materials on hypergolic fuels such as hydrazine.

Space Shuttle, Space Station Freedom, and future planetary mission vehicles will use hypergolic fuels such as hydrazine (refs. 1 and 2). The White Sands Test Facility (WSTF) has shown, using accelerating rate calorimetry (ARC), that materials do accelerate the decomposition of hydrazine, which can lead to explosions (ref. 3). Currently, a method has not been developed which can predict the long-term effects of materials on the decomposition of hydrazine (refs. 4 and 5). Pursuing this research could lead to a safer design of hypergolic propulsion systems which will be in use for extended periods of time.

The approach is to develop experimental procedures for the use of microcalorimetry to measure the ultra-low rate of heat release

caused by the slow rate of the metal-catalyzed decomposition of hydrazine at, or near, room temperature. Using these procedures, the catalytic effects of a number of metals and alloys on the rate of hydrazine decomposition will be studied. Methods would then be developed to identify and separate short-term effects from those effects important in determining long-term compatibility.

These methods and procedures will be validated by comparison of the microcalorimetric-based inferences to the results of in-house, long-term experiments and the results of other test methods. To further validate our conclusions, we would compare our results to previous long-term work from other sources.

In FY91, three major activities were emphasized. The experimental design and activities in support of the *long-term* experiments, which will be performed over the duration of this project (approximately 3 years), will be initiated. Survey and actual selection of a microcalorimeter, which will meet the needs

of this project, will be made. Development of computer models for the microcalorimetry data analysis to assist in predicting the long-term effects of materials on fuels will be completed.

In FY92, the microcalorimeter selected in FY91 will be procured. Microcalorimetry studies on materials used in the *long-term* experiments will also be initiated and standard methods will be established. Data relationships between microcalorimetry studies and the existing WSTF ARC studies will also be made. In parallel to these activities in FY92, analysis of some of the samples from the long-term experiments will be performed and correlation of this data to the microcalorimetry studies will be made.

In FY93, the major effort will be to analyze and correlate data from the long-term experiments and microcalorimetry studies will be made (refs. 4 and 5). This correlation will be used to verify the validity of computer models written that will extrapolate the data obtained from the microcalorimetry studies to predict the long-term effects of materials on hydrazine.

#### FY91 ACCOMPLISHMENTS

Design of the *long-term* experiments which will be performed over the duration of this project (approximately 3 years) has been initiated. This task involved the selection of material to be tested and of an experimental test system, and the development of a method to measure the pressure of each system accurately. Selection of the microcalorimeter, which will meet the needs of this project, has been made. The computer model that will be used for the analysis of the microcalorimetry data has been completed.

#### PLANNED FUTURE WORK

If the proposed method is successful in predicting, or is able to assist in the prediction of the long-term effects of metals on the decomposition of hydrazine, further evaluations on the effects of nonmetallic materials on the decomposition of hydrazine will be performed. The information from this work and future work will be incorporated into the updated editions of the NASA reference document "Fire, Explosion, Compatibility, and Safety Hazards of Hydrazine" (RD-WSTF-0002).

#### REFERENCE DOCUMENTS

1. Bennet, C. R.; Saw, D. R. B.; and Sutton, D.: "Laboratory Test at Elevated Temperatures for the Prediction of the Rates of Pressure Rise in Hydrazine Tanks at Normal Storage Temperatures," *Journal of Hazardous Materials*, vol. 4 (1980) p. 23.
2. Moran, C. M.; and Bjorklund, R. A.: Test Program to Demonstrate the Stability of Hydrazine in Propellant Tanks. Final Report, JPL Publication 83-37, April 1983.
3. Davis, D. D.; and Wedlich, R. C.: Transition Metal Catalysis of the Heterogeneous Decomposition of Hydrazine: Adiabatic Kinetics by Accelerating Rate Calorimetry. *Thermochimica Acta*, 175, 1991, 175.
4. Schmmidt, E. W.: Hydrazine and its Derivatives, Preparation, Properties and Applications. John Wiley & Sons, NY, 1984.

5. Chang, E. T.; and Gokcen, N. A.: Compatibility of Alloys with Hydrazine Containing Freon. The Aerospace Corporation, El Segundo, CA, report no. SAMSO-TR-76-34, February 1976.

---

---

**TITLE OF INVESTIGATION:** Real-Time Multipurpose Monitor for Assessing the Integrity of Confined Atmospheres

**PROJECT MANAGER:** Harold D. Beeson/RA/FTS 572-5542

FUNDING:	FY90	FY91	(Projected)	
			FY92	FY93
JSC Dir. Disc. Fund	\$40k	\$60k	\$60k	
Other	\$5k			

---

---

## OBJECTIVE AND APPROACH

The objective of this study is to develop and demonstrate a prototype system capable of real-time monitoring of confined atmospheres with artificial intelligence (AI) generated feedback.

The project is divided into three phases that correspond to the 3 years of requested funding. In Phase 1 (FY91), existing detector technology was reviewed, and appropriate gas and vapor data was identified and collected. The fabrication of a bench-scale test and monitoring system began using existing hardware. The end result of Phase 1 was a demonstration of the feasibility of Phase 2.

In Phase 2 (FY92), hardware will be purchased, and fabrication of the bench-scale test and monitoring system will be completed. The design of a configurational test system will be initiated, and the data base and diagnostic software for the next phase of testing will be developed. The software development will include an AI interface capable of automating the data acquisition and analysis process.

Phase 3 (FY93) will complete the study and will require the completion of the AI interface and a checkout of the configurational test system. The monitoring system (hardware and software) will be evaluated using the configurational test system as a mockup environment.

## FY91 ACCOMPLISHMENTS

In FY91, 46 literature references have been accumulated describing on-line monitoring methods or pattern recognition techniques as part of our technical review. These references have been organized into a Keyword data base. The technology review also involved attendance at key scientific meetings and contacts with knowledgeable experts in related fields. The result of information gained was that a mass spectrometric-based detector is the best candidate for this study.

An atmospheric interface for the mass spectrometer has been identified and tested using a temporary test fixture for acquiring signatures on overheated wires with Kapton-based wire insulations. This temporary test fixture, shown in figure 37, was used to develop

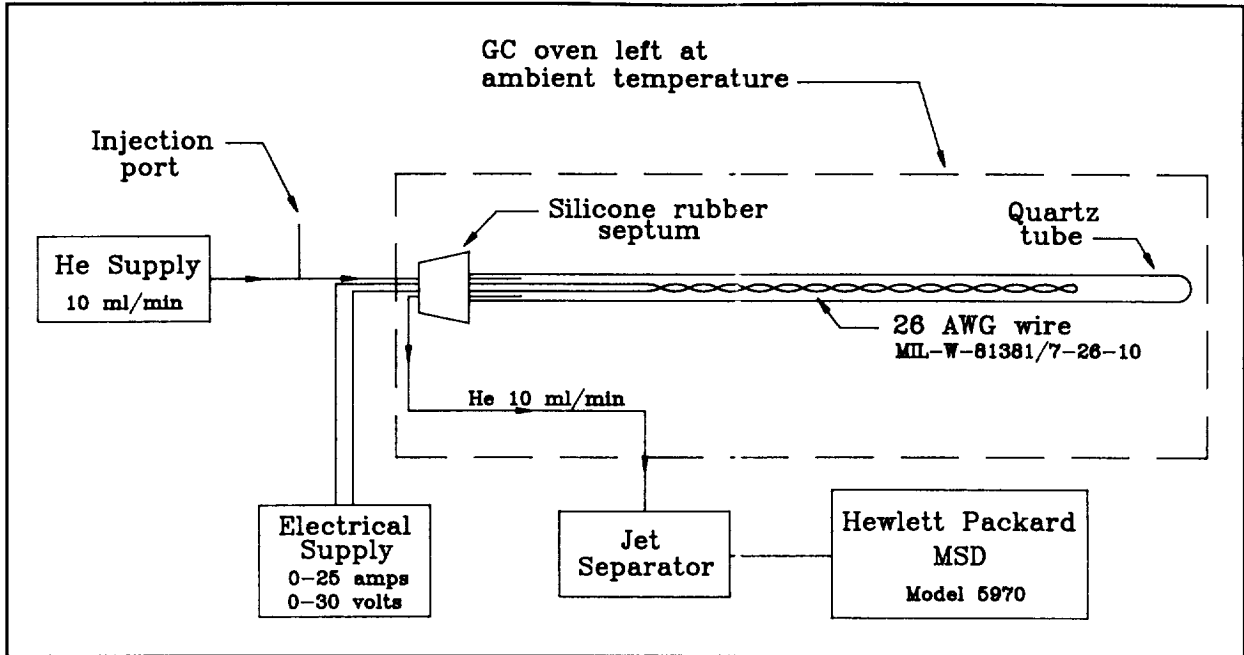

Figure 37.-- Bench-scale apparatus used to verify concept of real-time mass spectral analysis.

design requirements for the bench-scale test fixture. The procedures necessary to construct part of the required *event* data base from off-gas data present at the White Sands Test Facility were established.

Importantly, the feasibility of FY92 tasks was demonstrated. That is, drastically different events show visually discernible mass spectral features. More subtle differences in events (wire at use temperature, overheated, and at thermal runaway) also show different mass spectral features. It was therefore concluded feasible to develop unsupervised pattern recognition algorithms.

## PLANNED FUTURE WORK

In Phase 2 (FY92), the project team will work to identify and purchase all necessary hardware to fabricate the configurational test system and to develop the data base and diagnostic

software. Furthermore, data acquisition and unsupervised pattern recognition techniques will be developed and integrated into the AI interface.

Phase 3 (FY93) is targeted for completion of the AI interface and establishment of a supervised learning system for characterizing unknown classifications of *events*. The configurational test system will undergo checkout, and the entire monitoring system (hardware/software) will be evaluated in the mockup environment.



# REPORT DOCUMENTATION PAGE

*Form Approved*  
OMB No. 0704-0188

Public reporting burden for this collection of information is estimated to average 1 hour per response, including the time for reviewing instructions, searching existing data sources, gathering and maintaining the data needed, and completing and reviewing the collection of information. Send comments regarding this burden estimate or any other aspect of this collection of information, including suggestions for reducing this burden, to Washington Headquarters Services, Directorate for Information Operations and Reports, 1215 Jefferson Davis Highway, Suite 1204, Arlington, VA 22202-4302, and to the Office of Management and Budget, Paperwork Reduction Project (0704-0188), Washington, DC 20503.

1. AGENCY USE ONLY ( <i>Leave blank</i> )	2. REPORT DATE <b>November 29, 1991</b>	3. REPORT TYPE AND DATES COVERED <b>Annual FY91</b>	
4. TITLE AND SUBTITLE <b>JSC Center Director's Discretionary Fund Program 1991 Annual Report</b>		5. FUNDING NUMBERS <b>307-51</b>	
6. AUTHOR(S) <b>Lyle M. Jenkins, Editor</b>			
7. PERFORMING ORGANIZATION NAME(S) AND ADDRESS(ES) <b>New Initiatives Office NASA Johnson Space Center Houston, Texas 77058</b>		8. PERFORMING ORGANIZATION REPORT NUMBER <b>S-664</b>	
9. SPONSORING / MONITORING AGENCY NAME(S) AND ADDRESS(ES) <b>NASA Washington, DC 20546</b>		10. SPONSORING / MONITORING AGENCY REPORT NUMBER <b>TM 104745</b>	
11. SUPPLEMENTARY NOTES			
12a. DISTRIBUTION / AVAILABILITY STATEMENT <b>Unclassified, unlimited</b>		12b. DISTRIBUTION CODE	
13. ABSTRACT ( <i>Maximum 200 words</i> ) <b>The JSC Center Director's Discretionary Fund Program 1991 Annual Report provides a brief status of the projects undertaken during the 1991 fiscal year. For this year, four space exploration initiative related issues were focused on: regenerative life support, human spacecraft design, lunar surface habitat, and <i>in situ</i> resource utilization. In this way, a viable program of life sciences, space sciences, and engineering research has been maintained. For additional information on any single project, the individual investigator should be contacted.</b>			
14. SUBJECT TERMS <b>Space Exploration Initiative, regenerative life support, human spacecraft design, lunar surface habitat, artificial intelligence, <i>in situ</i> resources.</b>		15. NUMBER OF PAGES <b>84</b>	16. PRICE CODE
17. SECURITY CLASSIFICATION OF REPORT <b>Unclassified</b>	18. SECURITY CLASSIFICATION OF THIS PAGE <b>Unclassified</b>	19. SECURITY CLASSIFICATION OF ABSTRACT <b>Unclassified</b>	20. LIMITATION OF ABSTRACT <b>unlimited</b>