

NASA/CR-1998-208968



# A Microsoft Project-Based Planning, Tracking, and Management Tool for the National Transonic Facility's Model Changeover Process

*Daniel M. Vairo*  
*Lockheed Martin Engineering & Sciences Company*  
*Hampton, Virginia*

National Aeronautics and  
Space Administration

Langley Research Center  
Hampton, Virginia 23681-2199

Prepared for Langley Research Center  
under Contract NAS1-96014

---

December 1998

---

Available from:

NASA Center for AeroSpace Information (CASI)  
7121 Standard Drive  
Hanover, MD 21076-1320  
(301) 621-0390

National Technical Information Service (NTIS)  
5285 Port Royal Road  
Springfield, VA 22161-2171  
(703) 605-6000

## **Introduction**

The removal and installation of sting-mounted wind tunnel models in the National Transonic Facility (NTF) is a multi-task process having a large impact on the annual throughput of the facility. Approximately ten model removal and installation cycles occur annually at the NTF with each cycle requiring slightly over five days to complete. The various tasks of the model changeover process were modeled in Microsoft Project as a template to provide a planning, tracking, and management tool. The template can also be used as a tool to evaluate improvements to this process. This user's guide describes the development of the template and provides step-by-step instructions on its use as a planning and tracking tool. A secondary role of this document is to provide an overview of the model changeover process and briefly describe the tasks associated with it.

## **Facility Description**

The NTF is a fan-driven, closed-circuit, continuous-flow, pressurized wind tunnel capable of operating with either nitrogen or air as the test gas. Figure 1 presents an aerial view of the NTF and Figure 2 shows a plan view of the tunnel circuit. The NTF's square test section has a height and width of approximately 8.2 feet and a longitudinal length of 25 feet. The test section's top and bottom walls have six slots each and the combined width of each set of six is 6% of the width of the wall. Figure 3 shows a model of a transport configuration mounted in the test section. The NTF has a Mach number range of 0.1 to 1.2 and a Reynolds number range of  $3 \times 10^6$  to  $120 \times 10^6$  at a Mach number of 1.0 (based on a reference chord of 0.82 feet). The pressure and temperature ranges are 15 to 130 pounds per square inch (psia) and  $-250^\circ$  to  $150^\circ$  Fahrenheit (F) respectively. The operational envelope of the NTF is shown in Figure 4.

## **Microsoft Project Template of the NTF Model Changeover Process**

The model changeover process starts with the completion of the previous test program and the test section conditioned to a safe and comfortable work environment. The model changeover process consists of the Tunnel Inspection and Maintenance work package, the Model and Instrumentation Installation work package, and the Tunnel Close Out work package. It is also assumed that the model buildup process for the next model has been completed on or before the start date of the model changeover process. Figure 5 presents the three work packages, their associated tasks, and the average time to complete each task in hours. A majority of the model changeover tasks can be completed in less than half a work shift with a few tasks requiring a whole shift. Note that both the tunnel inspection and maintenance tasks require upwards of 10 shifts each if resource constraints exist and tasks cannot be performed concurrently. The NTF currently operates on a two-shift basis. The first shift starts at 7:00 AM and ends at 3:30 PM and the second shift starts at 3:15 PM and ends at 11:45 PM. A brief description of each task is included in Appendix I of this document.

A computer model of the NTF's model changeover process was developed using Microsoft Project. Microsoft Project is a project management program with a graphical interface. Microsoft Project allows the project manager to plan and track a project within the boundaries of a given set of resource constraints. This computer model was created in a template format so that it can be utilized as a changeover planning and tracking tool on numerous occasions. The first step in the creation of this template was the entry of the changeover process's three work packages, their associated tasks, and the average time to complete each task into Microsoft Project's Task Name and Duration columns respectively. Project utilizes this information to create Gantt and PERT charts. Figure 6 shows the model changeover tasks and their associated durations as they appear in the planning template. Microsoft Project automatically assigns each task an ID number and these ID numbers are shown in column one of Figure 6. For example, ID number 37 is assigned to the "Perform Instrumentation Checkout" task. Additional information on

entering task information and creating basic Gantt and PERT charts can be obtained from the Microsoft Project manual (Reference 1).

The next step during the creation of the changeover template was the analysis of task dependencies and the sequence of events. If the tasks for a given project are properly linked one to another, Microsoft Project automatically calculates the impact that a given task has on the start and finish dates of one or more other tasks in the same project. This is accomplished by utilizing Project's Link command. The Link command establishes a relationship or dependency between the start and finish dates of one or more tasks. Four types of relationships can be assigned in Project but only the finish-to-start relationship was used throughout the NTF model changeover template. The finish-to-start relationship establishes that task "B" cannot start until task "A" finishes. Microsoft Project assigns task "A" as the predecessor of task "B" and assigns task "B" as the successor of task "A". For example, the "Move Empty Cart to Test Section" task in the changeover template cannot start until the "Install Ramp and Floor Plates" task is finished. Another example is that the "Remove Model Sting From Stub Sting & Secure to Cart" task cannot start until the "Move Empty Cart to Test Section" task is finished. These three tasks are linked in the changeover template and occur serially with the installation of ramp and floor plates occurring first, followed by moving the empty cart to the test section, and lastly by the removal of the model sting from the stub sting and securing it to the cart. Therefore, a delay in the completion of the "Install Ramp and Floor Plates" task adversely impacts the start and finish dates of the other tasks that are dependent upon the installation of the ramp and floor plates.

The predecessor(s) and successor(s) of each task in the NTF model changeover process was determined and these relationships are shown in the Predecessor column of the Task Sheet shown in Figure 7. The Task Sheet is one of the many views a user can define in Microsoft Project (see manual). These relationships were defined in Microsoft Project by entering into the Predecessor column the ID number of the task that is a predecessor for a given task. This entry creates a link between this task and its predecessor. A task can have one or more assigned predecessors. An example of a

simple relationship as defined in the changeover template is shown in Figure 7. The entry of ID number 9 next to the “Disconnect Model Wiring/Tubing” task signifies that task number 9 (“Open JB-16”) must be completed before the “Disconnect Model Wiring/Tubing” task can start. All of the tasks in the model changeover template are linked to one or more other tasks throughout the template. Therefore, a delay in the completion of one tasks adversely impacts the start and finish dates of other tasks that are dependent upon the completion of that task. On a macro basis, this delay may adversely effect the completion of the project (changeover process in this case) if the delayed task(s) is on the critical path of the project. The critical path as defined by Microsoft Project is “the series of tasks that must be completed on schedule for a project to finish on schedule. Each task on the critical path is a critical task.” The critical path of the NTF model changeover process will be discussed in a subsequent section of this document. Additional information on the task link command, establishing task dependencies, and critical path analysis can be obtained from the Microsoft Project manual (Reference 1).

Another analysis was conducted to determine which tasks of the NTF model changeover process were conducted in parallel and which tasks were conducted in a serial sequence. Though a majority of the model changeover tasks occur in a serial sequence, a few of the tasks occur in parallel with other tasks. Figure 6 presents the template and shows the timeline or Gantt chart of an example of a project scheduled to start on Friday the 18th of April. Note that the tasks associated with the “Previous Model Removal” and “Model Installation” subwork packages generally occur in a serial sequence of events with the exception of the opening of JB-16 and the movement of the nearside access housing from the vapor enclosure to the third floor. These tasks are executed in parallel. Another example of parallel scheduled events is the execution of the “Set Up Deck & Data Reduction Verification” task in parallel with the “Tunnel Patchboard Installation” and “Configuration of Tubing Per AIP-29.6” tasks. Given the appropriate resources for a given project, scheduling tasks in parallel tends to compress the overall duration of the project.

As stated earlier in this document, the NTF's model changeover process consists of the following three work packages: Tunnel Inspection and Maintenance, Model and Instrumentation, and Tunnel Close Out. To further assist in the planning and tracking of the NTF model changeover process, the tasks of the "Model and Instrumentation" work package were organized under the following subwork packages: Previous Model Removal, Model Installation, and Instrumentation Installation/Checkout and Final Model Checkout. Figure 6 presents these subwork packages and their associated tasks along with the projected time to complete each major task. The "Previous Model Removal" subwork package requires the least amount of time to complete and starts immediately after access to the test section is allowed. This subwork package takes approximately 0.47 days to complete. The "Model Installation" subwork package starts immediately after the previous model is removed and requires approximately 0.91 days to complete due to the work associated with its "Fit Access Housing Seals" task. Fitting the access housing seals requires approximately 7.5 hours and this task is described in Appendix I. The "Instrumentation Installation/Checkout and Final Model Checkout" subwork package has the largest number of associated tasks and requires approximately 2.89 days to complete. The setup of video cameras, leak check of model orifices, and the readying of the data acquisition system each require approximately eight hours to complete. The overall time to complete the "Model and Instrumentation" work package is approximately 2.89 days since a number of tasks in the subwork packages are scheduled and executed in parallel.

Figure 6 also shows that the time to complete the "Tunnel Inspection and Maintenance" and "Tunnel Close Out" work packages are 5.0 and 0.44 days respectively. Combining the three work packages results in the overall duration of the NTF model changeover process being slightly less than 5.5 days of two shift operations. One interesting observation is that the "Model and Instrumentation" work package is not on the critical path whereas the "Tunnel Inspection and Maintenance" and "Tunnel Close Out" work packages are. The tunnel inspection and maintenance tasks have a net impact of adding 1.67 days beyond the completion of all model, instrumentation and close out tasks. *In theory, the typical NTF model changeover process could be completed in*

*approximately 3.33 days if resources are available to complete all inspection and maintenance tasks in parallel with and during the same time period that the model and instrumentation tasks are executed (approximately 2.89 days).*

## **Procedure for Using Template of NTF Model Changeover Process**

### **A. Forward Fill and Back Fill Modes of Operation**

The use of the NTF model changeover template is relatively simple since all of the standard tasks associated with the changeover process have been pre-entered and linked in the template. The template is configured to automatically calculate and forward fill the start and finish dates of all the changeover tasks based on the entry of the desired start date. The desired start date is entered in the “Start” column next to the “Previous Model Test Completed” task name. For example, Figure 6 presents the start and finish dates of all tasks based on a 4/21/97 start date or in this case the completion date of the previous test program. The forward fill mode is the changeover template’s default.

The template can also be configured to operate in a back fill mode if the changeover process must be completed on a known date. In this mode the template will automatically calculate and back fill the start and finish dates of all the changeover tasks based on the entry of the desired completion date. The desired completion date is entered in the “Finish” column next to the “Tunnel/Model Ready for Test Operations” task name. For example, Figure 8 presents the start and finish dates of all tasks based on a 5/15/97 finish date or in this case the model and tunnel being declared ready for test operations. In this mode, Microsoft Project calculates the latest date a task can start without adversely impacting the overall finish date of the changeover. This is based on the assumption that the tasks are completed within their planned duration. To reconfigure the template to the



back fill mode, the user selects Summary Info under the File menu, selects Project Finish Date in the dialog box and enters the desired Finish Date in the dialog box.

## **B. Revising the Task List and the Information Associated With a Task**

As the NTF model changeover process evolves over time, it may be necessary to add tasks, delete tasks, revise durations, and revise the relationships between tasks. Though adding and deleting tasks is relatively simple, care must be taken to ensure that the predecessor(s) and successor(s) assigned throughout the template continue to reflect the changeover process. The procedure used to add a task is listed below:

- 1) Click on the task in the list that will follow the added task
- 2) Click on Insert Task under the Insert menu to add the task
- 3) Enter the new task's name in the Task Name column
- 4) Press the return key
- 5) Enter the time required to complete the new task in the Duration column
- 6) Press the return key

Confirm that the new task's predecessor(s) are correctly shown in the Predecessor column. If the information is not shown correctly, enter the ID number(s) of the new task's predecessor(s) in the Predecessor column. If the new task is the predecessor of other tasks in the template, confirm that the new task's ID is shown in the Predecessor column of the new task's successors. If the information is not shown correctly, enter the new task's ID number. The procedure used to delete a task is listed below:

- 1) Click on the task to be deleted in the list
- 2) Click on Delete Task under the Edit menu to delete the task
- 3) Confirm that the predecessors listed throughout the template continue to reflect the changeover process

The revision of a task's duration is accomplished by clicking on the task's duration in the Duration column followed by entering the new time required to complete the task. The revision of a task's predecessor(s) is accomplished by clicking on the task's predecessor information in the Predecessor column followed by entering the revised predecessor information. Additional information on adding, deleting, and revising task information can be obtained from the Microsoft Project manual (Reference 1).

### **C. Establishing a Baseline and Tracking the Progress of a Project**

Microsoft Project provides the user with a tool to track the actual progress of a project and compare this progress to a planned baseline schedule. Microsoft Project utilizes the actual progress information of the project's completed tasks to calculate the start and finish dates of the project's future tasks and predict a completion date for the project. The NTF model changeover template has been pre-formatted to automatically present a Gantt chart of the actual progress of the changeover alongside a Gantt chart of the planned baseline schedule of the changeover. The user can utilize this information to determine if the project is tracking on schedule or if it is deviating from the planned schedule and also determine if and when corrective action should be taken. Figure 6 shows the model changeover template with tracking information presented (baseline vs. actual). The following sections will describe how the user can establish the baseline schedule, enter actual progress information, and describe the features of this tracking tool.

A baseline schedule in Microsoft Project is a schedule with start dates, finish dates, and durations that should not be revised without the project manager's approval. The first step in the creation of a baseline schedule is the user modifying the template by either the forward fill mode or the back fill mode as discussed in the above section. Once the user is satisfied that the schedule reflects the start or finish constraints of the changeover, the next step is to convert and "freeze" this schedule as the baseline. The procedure used to convert and freeze a schedule into a baseline schedule is listed below:

- 1) Select Tracking and Save Baseline under the Tools menu
- 2) Select the Save Baseline and Entire Project options in the dialog box
- 3) Click on the OK button to convert and freeze the schedule into a baseline

By default, the baseline schedule and the actual progress schedule coincide at the beginning of the changeover and this is presented in Figure 6.

The features shown in Figure 6 have been pre-formatted. The actual progress schedule is presented as open bars above the shaded bars of the baseline schedule. If the user is using a color monitor or printer the open bars will have a blue outline for non-critical tasks and a red outline with light red shading for critical tasks. The baseline schedule is plotted below the actual schedule and is depicted by solid medium gray bars. Baseline milestones are shown as open medium gray diamonds within a circle. Actual progress milestones are shown as open blue triangles. Summary bars are outlined in black and have inverted triangles that represent start and finish dates. The percentage of completion of each task is presented to the right of the each task bar and is also depicted by the open bar being filled at the same ratio. The fill color is solid blue for non-critical tasks and solid red for critical tasks.

The user has the option of revising the information in the “Start”, “Finish”, “Duration”, and “% Complete” columns to reflect the actual progress of the model changeover process. Figure 9 presents an example of a model changeover that started on Monday the 21st of April and has been revised to reflect the progress as of the 23rd of April. The figure presents a deviation from the planned baseline schedule. Each work package will be discussed in detail in the following sections.

As shown in Figure 9, the “Tunnel Inspection and Maintenance Work Package” is 38% complete as of Wednesday the 23rd of April. The inspection of the tunnel started on time and is 50% complete. The start of tunnel maintenance was delayed one day and is 25% complete. Since the tunnel maintenance task is on the critical path of the changeover process, the one day delay of the start of this task adversely impacts the

completion date of the overall changeover process by one day. The changeover process was originally planned to be completed on the 28th of April but is now projected to be completed on the 29th of April due to the delay.

Figure 9 also shows that the “Model and Instrumentation Work Package” is 60% complete as of Wednesday the 23rd of April. The “Previous Model Removal”, “Model Installation”, and “Instrumentation Installation/Checkout and Final Model Checkout” subwork packages are 100%, 100%, and 35% complete respectively. The first four subtasks of the “Previous Model Removal” subwork package were completed on time and within their planned duration. The movement of the empty cart to the test section started on time but was completed late since it required five hours to complete instead of the planned one hour. This four hour delay causes a domino effect of delaying the start of all its dependent changeover tasks by four hours. This is depicted in Figure 9 as a four hour timeline shift to the right of all tasks that are dependent on the timely movement of the empty cart to the test section. All other tasks of the “Previous Model Removal” subwork package were completed within their planned duration.

The “Securing Model Sting to Stub Sting” subtask of the “Model Installation” subwork package was also completed late since it required 16 hours to complete instead of the planned one hour. This 15 hour delay also delays the start of all its dependent changeover tasks by 15 hours. This is also depicted in Figure 9 as a timeline shift to the right. The magnitude of the shift is 19 hours due to the cumulative effect of this 15 hour delay and the four hour delay discussed above. All other tasks of the “Model Installation” subwork package were completed within their planned duration.

Figure 9 also shows that the start dates of all but four of the subtasks associated with the “Instrumentation Installation/Checkout and Final Model Checkout” subwork package were also affected by the 19 hours of cumulative delays. The start dates of the patchboard installation, configuration of tubing, set up deck, and data acquisition tasks were not effected since they did not depend on the finish dates of the tasks that were completed late. The figure shows that these four tasks were also completed on time. The

connection of the model's wiring and tubing was also completed within its planned duration though it too was effected by the cumulative delays. Also, as of Wednesday the 23rd of April, the video camera task was 50% complete.

#### **D. Total Slack Time**

Total slack time information is also presented in Figure 9. The total slack time as defined by Microsoft Project is, "the amount of time a task can be delayed without delaying the project finish date." For example, the figure shows that as of Wednesday the 23rd of April the "Close JB-16" task can be delayed up to 1.97 days without adversely impacting the overall process finish date. Notice that the total slack times of the tunnel inspection and maintenance tasks have a value of zero. This indicates that any delay associated with these tasks will adversely impact the overall finish date of the changeover process. This was illustrated in an earlier section of this report. Slack time allows a project manager to reallocate shared resources. Resources can be shifted from the task(s) having excess slack time to the task(s) that have little or no slack time.

#### **E. Viewing Graphical Links**

Microsoft Project has the capability to graphically show a link between predecessor and successor tasks. This feature assists the user in viewing the relationships between various tasks throughout the project. A task relationship is indicated as a line originating from the predecessor task and ending at the successor task. The line terminates with an arrow. To minimize introducing clutter to the view of the changeover template, the template was created without the links shown. The user can easily view the template with the links shown by selecting Layout under the Format menu. In the dialog box select the desired link format followed by clicking on the OK button. Figure 10 shows the template with the task relationships graphically depicted. It is important to

note that the previous model removal process starts at the same time the tunnel patchboard and verification process begins for the next model.

#### **F. Viewing PERT Chart Information**

The user can utilize Microsoft Project's PERT chart function to graphically display a project's tasks and the relationship between these tasks as a flow chart or network diagram. The PERT chart view generally shows tasks relationships more clearly than the Gantt chart view. The model changeover template is pre-formatted to show a Gantt chart as its default view. The user can easily convert the changeover template from the Gantt chart format to the PERT chart format by selecting PERT Chart under the View menu. Figure 11 shows selected tasks of the changeover template in a PERT chart format. The critical path shown in this figure does not represent the critical path of the changeover process but represents the critical path of a project having only the tasks shown.

### **Concluding Remarks**

A two-phase project was undertaken to document the model changeover process at the National Transonic Facility and develop a Microsoft Project-based model of this process. The description of the changeover process in this document provides a foundation for future process improvement evaluations and also provides a training tool by presenting an overview for individuals not familiar with NTF operations.

The Microsoft Project-based template of the model changeover process is a new tool for planning, tracking, and managing the numerous activities of the model changeover. The template provides a standardized visual plan of the process and automatically generates a schedule of the changeover activities based on the user's input of a process start or finish date. The schedule can be converted into a baseline schedule

and the user can track the actual progress of the changeover by entering actual start and finish dates for each activity.

The template of the model changeover process can be used to evaluate the current process and the impact of future process improvements on the total duration of a model changeover. A preliminary evaluation during the development of this template showed that the overall duration of the changeover process can be reduced by roughly 40% if all inspection and maintenance tasks are completed during the same time period that the model and instrumentation tasks are executed. The NTF can realize a gain of roughly four additional test weeks annually if this process improvement occurs.

The preliminary evaluation of the changeover process also showed that the previous model removal process and the installation process for the next model could start at the same time and occur in parallel for approximately one half of a day. The NTF can realize a gain of roughly one additional test week annually if the parallel sequencing of these activities is implemented.

The development of a computer-based tool to assist in the management of the NTF's model changeover and the documentation of that process is the first of its kind at NASA Langley Research Center. It is envisioned that this project will be used as a guide during the development of similar tools for the other wind tunnels at NASA Langley Research Center.

## **Appendix I - Overview of the NTF Model Changeover Process Including a Brief Description of Tasks**

This Appendix will provide an overview of the NTF model changeover process including a brief description of the tasks involved in this process. The model changeover process starts with the completion of the previous test program and the test section conditioned to allow access. As discussed in earlier sections of this report, the model changeover process consists of the following three work packages: Tunnel Inspection and Maintenance, Model and Instrumentation, and Tunnel Close Out. These work packages and their associated tasks are shown in Figure 6. Each task is assigned an identification number as shown in the figure.

### **Tunnel Inspection and Maintenance Work Package**

As shown in Figure 6 the NTF tunnel inspection and maintenance tasks require upwards of 10 shifts each if there are resource constraints. The tunnel inspections are a series of post test inspections and examples of items inspected include fan blades, tunnel insulation, inlet guide vanes, screens, structural components, and ancillary systems. The post-test inspection is guided by the NTF's Integrated Operational Procedure (IOP) number 106B. The maintenance process includes both routinely scheduled maintenance and the post-test repair of equipment if required. The maintenance workload varies between test programs and the goal is to accomplish these tasks within 10 shifts or less.

### **Model and Instrumentation Work Package**

#### **A. Model Removal Process**

The model removal process as shown in Figure 6 requires approximately 0.47 days to complete. This process starts with the opening of JB-16 and the disconnection of



the model's instrumentation wiring, pressure tubing, balance cooling lines and purge lines. JB-16 is an instrumentation junction box located in the arc sector of the NTF's model support system. This junction box is utilized as an area to connect the wiring and tubing from the model to the permanent wiring and tubing leading from this junction box to instrumentation external to the test section. Figure 12 illustrates the NTF's model support system. JB-16 is located in the roll drive pod forward of the fixed fairing and is also shown in the rectangular cutaway section in the right-hand portion of Figure 13. The wiring and tubing can be seen entering JB-16 from the sting in the left-hand portion of Figure 14.

The next step in the model removal process is the repositioning of the tunnel access housing, ramp plates, and floor plates to allow the use of the model handling cart. The tunnel access housings are utilized to gain access to the model during a test program when the tunnel is in a cooled state. As illustrated in Figures 15 and 16, these tube-like housings are inserted from both sides of the test section through the test section access doors and form a thermally sealed enclosure around the model. The floors of the access housings cannot accommodate the model handling cart necessitating the removal of one housing. As shown in Figure 17, the access housing closest to the NTF's control room is lifted by an overhead crane and stored in the NTF's mezzanine level. Once the housing is removed the overhead crane is used to reposition the ramp and test section floor plates from the mezzanine level to the test section entry and test section respectively. The repositioning of the ramp is shown in Figure 18 and the installation of the test section floor plates is shown in Figure 19.

The installation of the floor plates is followed by the empty model handling cart being lifted by the overhead crane from the first floor shop area to the entry of the test section on the second floor. The model handling cart is used to transport the model and sting assembly and is supported by air bearings. The empty handling cart is moved into the test section and the model and sting assembly is secured to the cart before the model sting is disconnected from the stub sting. Figure 20 shows the empty cart positioned under the model and sting assembly in the test section. After the model sting is

disconnected from the stub sting, the model cart is used to transport the model and sting out of the test section. Figure 21 shows the model handling cart with the secured model and sting assembly being maneuvered out of the test section. The handling cart, with the model and sting secured, is then lifted by the overhead crane and lowered to the shop area. Figures 22 and 23 show the lift and lowering sequence respectively.

At this point in the model removal process the stub sting is the only item connected to the model support strut. The variation in model stings (i.e. taper, length, bend) at the NTF requires the use of a stub sting to provide a smooth transition from the model sting geometry to the geometry of the model support strut. The model sting is connected to the stub sting and the stub sting is connected to the NTF's model support strut. This arrangement is illustrated in Figure 24 and a disconnected stub sting is shown in Figure 25. If the stub sting requires removal due to a change in model sting geometry between test programs, an overhead winch mounted to a small transportable frame is moved into the test section. The stub sting is secured to the frame before it is disconnected from the model support strut. A stub sting in the process of being removed is shown in Figure 26. After the stub sting is disconnected, the frame is used to transport it out of the test section. The frame, with the stub sting secured, is then lowered to the shop area by the overhead crane.

The last task of the model removal process is the removal of the access housing seals. These seals are used to provide a thermal seal around the model sting when the access housings are in use. The inside contour of the access housing seals are the same as the outside contour of the model sting in their area of contact. Figures 15 and 27 show two different views of the contact area. The removal of the access housing seals is required if there is a change in model sting geometry between test programs.

## **B. Model Installation Process**

The model installation process, as shown in Figure 6, is a reverse process of the model removal process with the exception of connecting the model's instrumentation, closure of JB-16 and the installation of the access housing seals. The connection of the model's instrumentation wiring and tubing along with the closure of JB-16 occurs during the instrumentation installation process. The installation and fitting of the seals occurs at the end of the process and requires more time to install than to remove due to stringent sealing requirements at all interfaces. The installation and fitting of the seals requires approximately 7.5 hours to complete and is the most time-intensive task in the model installation process. The overall time required to complete the model installation process is approximately 0.91 days.

## **C. Instrumentation Installation/Checkout and Final Model Checkout**

As illustrated in Figure 6, the process that involves the installation of instrumentation, checkout of the instrumentation and the final checkout of the model has the largest number of associated tasks and requires approximately 2.89 days to complete. The installation of the patchboard, configuration of the tubing, and the setup and verification of the data acquisition system can start as soon as the previous wind tunnel test program is completed, therefore, there is an overlap of roughly 4 hours during the transition between test programs. All other tasks associated with this process depend on the installation of the model in the test section.

The installation and verification of the patchboard occurs in the NTF's control room. The patchboard is an interface between the tunnel and model instrumentation wiring and the data acquisition system. The patchboard is configured by use of jumpers to connect the instrumentation wiring to the desired data acquisition system channels. These connections are then verified to confirm the transmission of signals. The

installation and verification of the patchboard is guided by standardized procedures at the NTF.

The configuration-of-tubing task is the hookup to reference pressures for the tunnel's Electronically Scanned Pressure (ESP) transducers. This reference information is used during the data reduction and calibration processes. This setup task occurs outside the tunnel at the interface between the tunnel tubing and pressure gauges. This task is also guided by standardized procedures.

The setup deck is a computer file where constant test parameters are stored and accessed during the data acquisition and reduction process. These parameters are a function of the customer's data acquisition and reduction requirements, model geometry, and model/tunnel instrumentation. An example of a customer data acquisition and reduction requirement is the recording rate of data. Model weights and dimensions are model dependent parameters. Examples of model/tunnel instrumentation dependent parameters include ESP configuration, balance information, and Mach number system parameters. The data reduction system along with its setup deck is verified through trial runs at this point and throughout the installation and checkout of model instrumentation.

As shown in Figure 6, a majority of the tasks associated with the installation and checkout of the model's instrumentation, setup of video cameras and the final checkout of the model can only occur after the model is installed in the tunnel. The NTF's cameras are located in fixed viewing ports in the test section's ceiling and sidewalls. These cameras can be remotely tilted and panned to obtain the views desired by the customer. During the camera setup process the recorders are configured to record the desired views based on the test plan. The output of these cameras are also displayed at the test director's console and gives visual cues to the dynamics that the model is experiencing during a test run.

The connection of the model's instrumentation wiring and tubing occurs in JB-16 after the model sting has been connected to the stub sting. This task may include the

connection of wiring from the balance, angle-of-attack (AOA) package, thermocouples, strain gauges, and ESP package. This task may also include the connection of tubing for balance cooling lines, purge lines, and the reference, calibration, and control lines for the ESP package.

After the connections in JB-16 are completed, the task of leak checking the NTF's three ESP systems begins. During this task, the calibration, reference, and control lines for the model's ESP system, the tunnel's wall ESP system, and the tunnel's arc sector ESP system are checked for leakage. These lines originate from an instrumentation rack that resides outside the tunnel shell and are routed either to the model through JB-16, to the wall system, or to the arc sector.

With the completion of the leak check, the tasks associated with the instrumentation checkout can be performed. This process includes functionality checks of the instrumentation packages, patchboard, and the data acquisition system. This process includes checks to determine if the data acquisition system is recording raw inputs and converting these inputs to the proper engineering units. A subset of this process is the checkout of the balance and angle-of-attack (AOA) instrumentation. The sign convention of the normal force is confirmed by hand loading the balance in both the positive and negative directions. If required, a known force can also be applied to the balance as a response check. The sign convention of pitch attitude can also be determined during the hand loading process or the model can be pitched to a positive or negative attitude.

The next step in the instrumentation process is the leak check of the model's pressure measurement orifices. All of the orifices or a random sampling of the orifices will be checked depending on customer requirements. The model orifices are checked in the test section through use of a portable compressor. This compressor generates approximately five psi of negative pressure which in turn is applied to each orifice. This task can take as much as eight hours to complete if the number of orifices approaches four hundred.

Figure 6 shows that the next three tasks involve the installation of a flow blocker in JB-16, the securing of wiring and tubing in JB-16, and the closure of JB-16. The flow blocker is wool material and seals the gap where the wiring and tube bundles from the model penetrate JB-16. A silicon sealing compound is also used as an adhesive to seal this gap. The bundles are next secured in JB-16 by use of tie wraps and one final check of all connections occur. JB-16 is ready for closure at this point and the cover plate is secured and safety wired.

After the closure of JB-16, the pitch angle of the arc sector and the roll angle of the roll drive are recorded with the arc sector pitch pin installed. The pitch pin prevents the rotation of the arc sector during periods when the arc sector is not in use. The angular values are used as a pitch pin alignment check during the installation and removal of the pin during the test phase of operations.

The next task in the process is the installation of a leveling plate on the model. The leveling plate is a machined part and when mounted on the model has an upper surface that is parallel to the model's xy plane. This leveling plate is utilized to verify the model's attitude (roll & pitch angles) and calibrate the data acquisition system to read these known angles. During the "Zero Roll Pot to Model" task, an inclinometer is mounted on the model and the model is rolled until the inclinometer indicates a roll angle of zero. While the model is at a roll angle of zero the roll pot instrument is adjusted to output a value of zero. The roll pot is an instrument that senses the angular orientation of a device and outputs a signal that is proportional to this orientation. The model's pitch angle is calibrated in a similar manner by calibrating the output signals from the onboard angle of attack (AOA) and level (bubble) sensors. After the calibrations have been completed, the data acquisition system is exercised to verify that the polar parameters in the set up deck match the actual model's pitch and roll angles as the model's attitude is varied in the tunnel.

As shown in Figure 6, the next task is the checkout of the Balance Dynamic Display Unit (BDDU) and the Critical Point Analyzer (CPA). These instruments are part

of the NTF's model safety protection system and monitor the static and dynamic loads on the balance. The BDDU monitors the balance loads and provides an audible alarm in the control room when the loads approach predetermined limits. The CPA also monitors loads and is directly wired to the tunnel's Mach number and the pitch control system. The CPA has the capability to automatically reduce the tunnel's dynamic pressure and pitch the model to a zero AOA if the balance loads approach load limitations. A chart that describes the NTF's model safety protection system is shown in Figure 28. Figures 29 and 30 illustrate the BDDU and CPA displays.

With the completion of the BDDU and CPA checkout, the data acquisition system is declared under configuration control. At this milestone no changes to the data acquisition software and model instrumentation are allowed unless a formal procedure is followed. The NTF's procedures provide instructions to accomplish changes and, more importantly, provide historical documentation of these changes.

As shown in Figure 6, the next tasks involve the final checkout of the model. The leveling plate is removed from the model and the holes in the model to accommodate the leveling plate are plugged with a fast-curing bonding compound. Any model surface imperfections are also filled with compound. The cured compound is then sanded to ensure that the model's surface contour requirements have been met.

The Model Tare and Wind-off Tunnel Parameter Control (TPC) Polar Check are the last two tasks associated with the model and instrumentation work package. During a model tare a predetermined polar is used to sweep the model through a series of angles of attack and the balance values (force and moments) are recorded and stored. These values are a function of the model's weight and attitude and are used in the data reduction process during the test program. The Wind-off Tunnel Parameter Control (TPC) Polar Check involves using setup deck polars to sweep the model through a series of upright and inverted angles of attack. The model's actual pitch and roll angles are compared to the set point values in the setup deck.

## **Tunnel Close-out Work Package**

As presented in Figure 6 the tunnel close-out work package requires approximately 0.44 days to complete and involves the completion of pre-run inspections and checklists to ensure that the tunnel is in a safe condition to initiate testing. The tunnel pre-run inspection and close-out is accomplished through Integrated Operating Procedure (IOP) number 106A. As stated in the procedure, its purpose is to inspect the tunnel for cleanliness, find loose or foreign objects that may result in tunnel damage, ensure that no personnel are anywhere within the pressure shell, and ensure the integrity of the pressure shell's access openings. The pre-run checklist is detailed in IOP-107A and is formally reviewed during a meeting that includes the Facility Safety Head, Test Director, Facility Coordinator, and Test Project Engineer. The verification of the Micro B processor is part of the 107A checklist. As presented in the chart in Figure 28, the Micro B model protection microprocessor is part of the NTF's model safety protection system. Dynamic pressure and arc sector limits are input into this microprocessor and any violation of these limits will automatically fail-safe the main drive and the pitch system. The verification process is to ensure the arc sector's fail-safe position. The last checklist to be completed before the tunnel and model is declared operationally ready is the instrumentation pre-test checklist. This checklist is used to confirm that all model and tunnel instrumentation systems are in a ready state.



## References

1. User's Guide Microsoft Project: Business Project Planning System Version 4.0.  
Document Number PJ56960-0295. Microsoft Corporation, 1995.



Figure 1. Aerial View of the National Transonic Facility.

### PRINCIPAL COMPONENTS OF THE NTF CIRCUIT

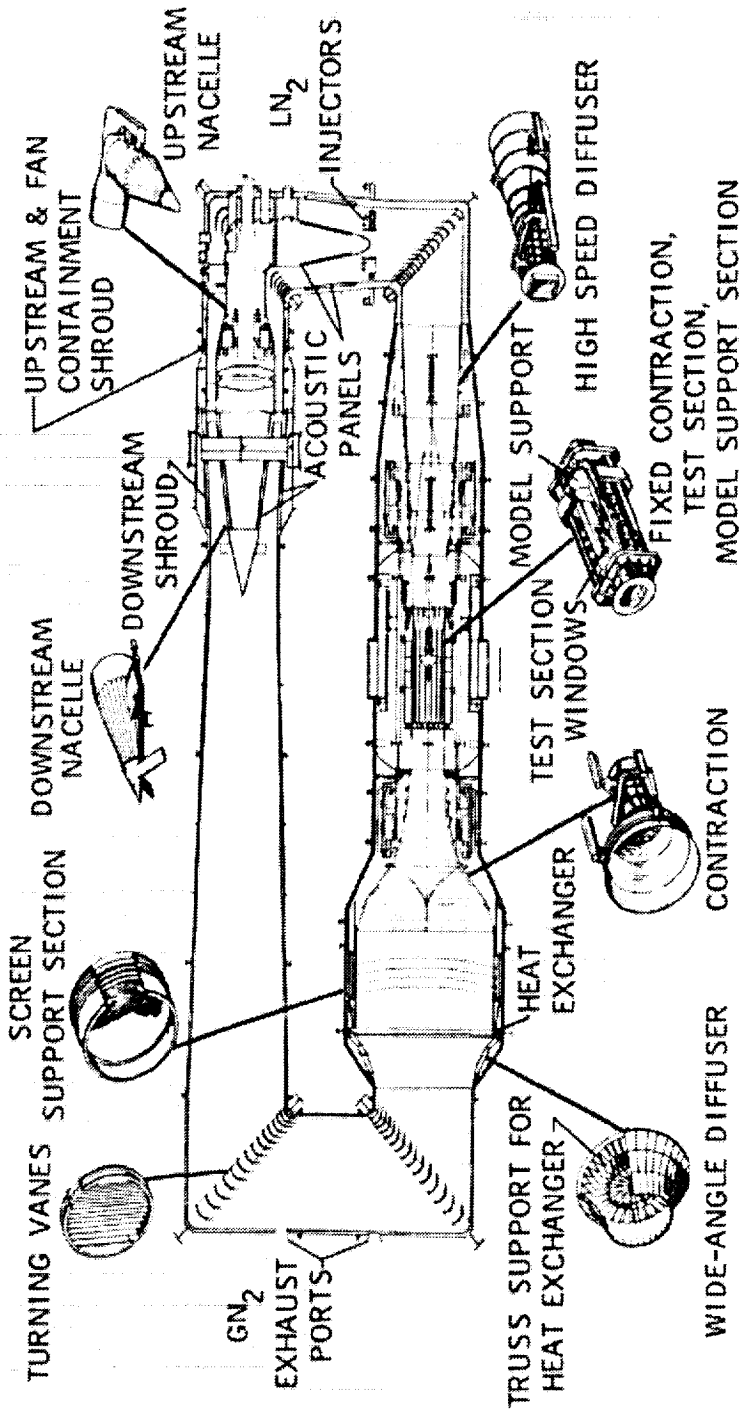

Figure 2. Plan view of NTF tunnel circuit.



Figure 3. Model mounted on sting in test section.

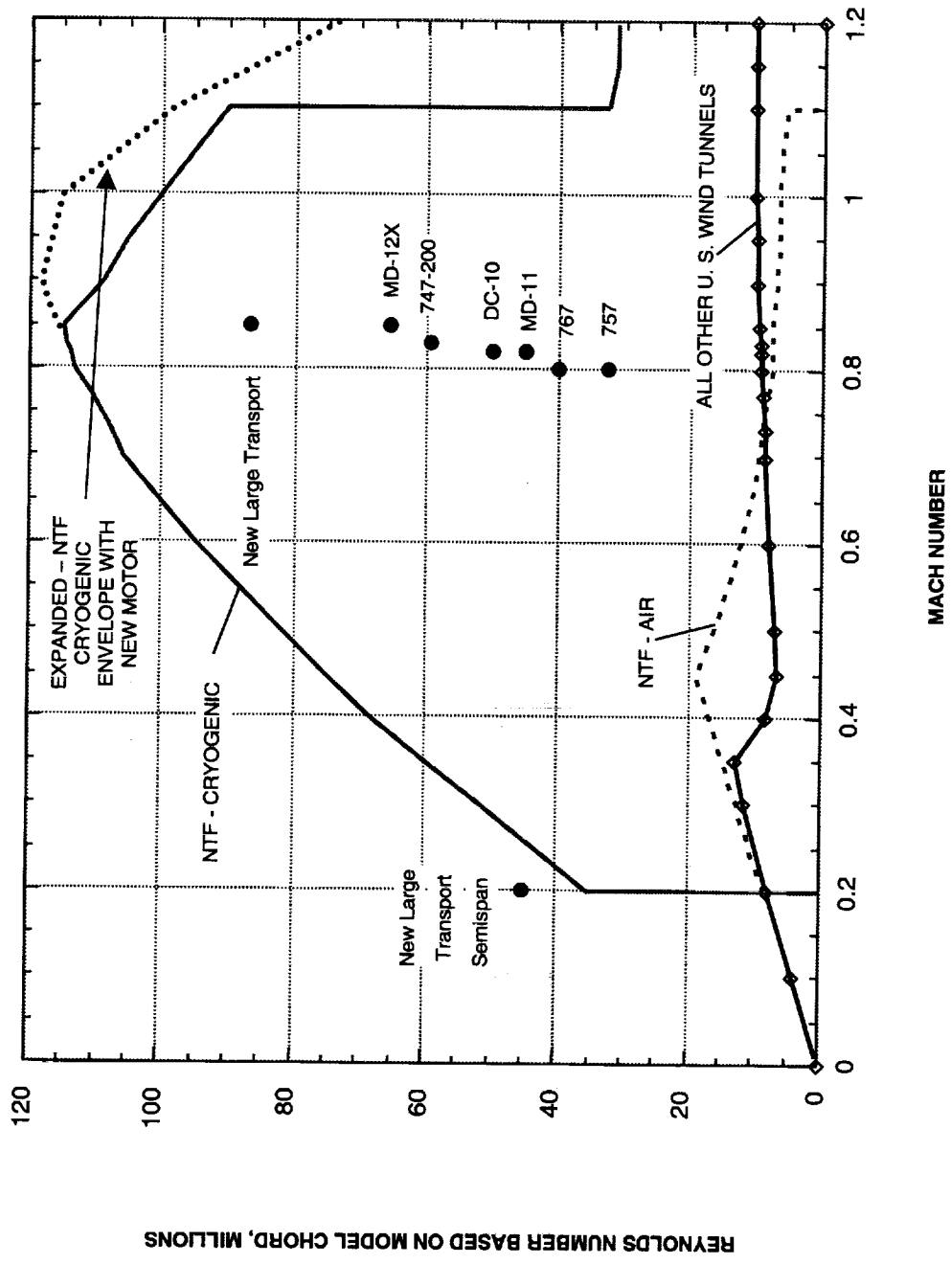

Figure 4. Operational envelope of the NTF.

ID	Task Name	Duration
1	<b>NTF Model Changeover Process</b>	<b>5.44d</b>
2		
3	Previous Model Test Program Completed	0h
4	<b>Tunnel Inspection and Maintenance Work Package</b>	<b>5d</b>
5	Tunnel Inspections	5d
6	Tunnel Maintenance	5d
7	<b>Model and Instrumentation Work Package</b>	<b>2.89d</b>
8	<b>Previous Model Removal</b>	<b>0.47d</b>
9	Open JB-16	1h
10	Disconnect Model Wiring & Tubing	1h
11	Move NS Access Housing From Vapor Enclosure to 3rd Floor	1h
12	Install Ramp & Floor Plates	1h
13	Move Empty Cart to Test Section	1h
14	Remove Model Sting From Stub Sting & Secure to Cart	1h
15	Move Model From Test Section to Shop	1h
16	Remove Stub Sting From Arc Sector & Move to Shop	2h
17	Remove Access Housing Seals	0.5h
18	Previous Model Removed	0h
19	<b>Model Installation</b>	<b>0.91d</b>
20	Move & Mount Stub Sting to Arc Sector	2h
21	Move Model From Shop to Test Section	1h
22	Secure Model Sting to Stub Sting	1h
23	Model Installed	0h
24	Move Empty Cart to Shop	1h
25	Remove Ramp & Floor Plates	1h
26	Move NS Access Housing From 3rd Floor to Vapor Enclosure	1h
27	Fit Access Housing Seals	7.5h
28	Model Installation Complete	0h
29	<b>Instrumentation Installation/Checkout and Final Model Checkout</b>	<b>2.89d</b>
30	Video Camera Setup & Calibration (wing twist & TSP tasks not included)	8h
31	Tunnel Patchboard Installation & Verification	1h
32	Configuration of Tubing per AIP-29.6	2h
33	Set Up Deck & Data Reduction Verification	8h
34	Data Acquisition System Ready to Take Data	0h
35	Connect Model Wiring & Tubing at JB-16	4h
36	Leak Check Control, Cal, Ref, Wall Sys (if required) & Arc Sector Lines	2h
37	Perform Instrumentation Checkout	4h
38	Hand Load Balance & AOA Instrumentation	0.25h
39	Perform Leak & Spot Check of Model Orifices	8h
40	Install Flow Blocker Behind Roll Drive	0.5h
41	Secure JB-16 Wiring & Tubing	1h
42	Close JB-16	1h
43	Install Leveling Plate and Pitch Pin Reading (pitch & roll)	4h
44	Zero Roll Pot to Model	1h
45	Model AOA & Bubble Calibration/Verification	1h
46	Balance Dynamic Display Unit and Critical Point Analyzer Checkout	1h
47	Data Acquisition System Under Configuration Control	0h
48	Remove Leveling Plate & Plug Holes	1h
49	Final Filing and Sanding of Model	4h
50	Model Tare	1h
51	Windoff/TPC Polar Check (upright & inverted)	1h
52	<b>Tunnel Close Out Work Package</b>	<b>0.44d</b>
53	Complete Close Out of Tunnel per IOP-106-A	4h
54	Complete IOP 107-A	1h
55	Micro "B" Arc Sector Verification	2h
56	Complete Instrumentation Pre-test Checklist	0h
57	Tunnel and Model Ready For Test Operations	0h

d =day    h =hours    1d =16 hours = 2 shifts

**Figure 5. Task list with durations.**

ID	Task Name	Start	Finish	Duration	% Complete	Total Slack	Sun Apr 28			
							6	12	6	12
1	<b>NTF Model Changeover Process</b>	Mon 4/21/97	Mon 4/28/97	5.44d	0%	0d				
2										
3	Previous Model Test Program Completed	Mon 4/21/97	Mon 4/21/97	0h	0%	0d				
4	<b>Tunnel Inspection and Maintenance Work Package</b>	Mon 4/21/97	Fri 4/25/97	5d	0%	0d				
5	Tunnel Inspections	Mon 4/21/97	Fri 4/25/97	5d	0%	0d				
6	Tunnel Maintenance	Mon 4/21/97	Fri 4/25/97	5d	0%	0d				
7	<b>Model and Instrumentation Work Package</b>	Mon 4/21/97	Wed 4/23/97	2.89d	0%	2.11d				
8	Previous Model Removal	Mon 4/21/97	Mon 4/21/97	0.47d	0%	2.11d				
9	Open JB-16	Mon 4/21/97	Mon 4/21/97	1h	0%	2.17d				
10	Disconnect Model Wiring & Tubing	Mon 4/21/97	Mon 4/21/97	1h	0%	2.17d				
11	Move NS Access Housing From Vapor Enclosure to 3rd Floor	Mon 4/21/97	Mon 4/21/97	1h	0%	2.11d				
12	Install Ramp & Floor Plates	Mon 4/21/97	Mon 4/21/97	1h	0%	2.11d				
13	Move Empty Cart to Test Section	Mon 4/21/97	Mon 4/21/97	1h	0%	2.11d				
14	Remove Model Sting From Stub Sting & Secure to Cart	Mon 4/21/97	Mon 4/21/97	1h	0%	2.11d				
15	Move Model From Test Section to Shop	Mon 4/21/97	Mon 4/21/97	1h	0%	2.11d				
16	Remove Stub Sting From Arc Sector & Move to Shop	Mon 4/21/97	Mon 4/21/97	2h	0%	2.11d				
17	Remove Access Housing Seals	Mon 4/21/97	Mon 4/21/97	0.5h	0%	2.11d				
18	Previous Model Removed	Mon 4/21/97	Mon 4/21/97	0h	0%	2.11d				
19	<b>Model Installation</b>	Mon 4/21/97	Tue 4/22/97	0.91d	0%	2.11d				
20	Move & Mount Stub Sting to Arc Sector	Mon 4/21/97	Mon 4/21/97	2h	0%	2.11d				
21	Move Model From Shop to Test Section	Mon 4/21/97	Mon 4/21/97	1h	0%	2.11d				
22	Secure Model Sting to Stub Sting	Mon 4/21/97	Mon 4/21/97	1h	0%	2.11d				
23	Model Installed	Mon 4/21/97	Mon 4/21/97	0h	0%	2.11d				
24	Move Empty Cart to Shop	Mon 4/21/97	Mon 4/21/97	1h	0%	3.63d				
25	Remove Ramp & Floor Plates	Mon 4/21/97	Mon 4/21/97	1h	0%	3.63d				
26	Move NS Access Housing From 3rd Floor to Vapor Enclosure	Mon 4/21/97	Mon 4/21/97	1h	0%	3.63d				
27	Fit Access Housing Seals	Mon 4/21/97	Tue 4/22/97	7.5h	0%	3.63d				
28	Model Installation Complete	Tue 4/22/97	Tue 4/22/97	0h	0%	3.63d				
29	<b>Instrumentation Installation/Checkout and Final Model Checkout</b>	Mon 4/21/97	Wed 4/23/97	2.89d	0%	2.11d				
30	Video Camera Setup & Calibration (wing twist & TSP tasks not included)	Mon 4/21/97	Tue 4/22/97	8h	0%	3.78d				
31	Tunnel Patchboard Installation & Verification	Mon 4/21/97	Mon 4/21/97	1h	0%	2.89d				
32	Configuration of Tubing per AIP-29.6	Mon 4/21/97	Mon 4/21/97	2h	0%	2.89d				
33	Set Up Deck & Data Reduction Verification	Mon 4/21/97	Mon 4/21/97	8h	0%	2.58d				
34	Data Acquisition System Ready to Take Data	Mon 4/21/97	Mon 4/21/97	0h	0%	2.58d				
35	Connect Model Wiring & Tubing at JB-16	Mon 4/21/97	Mon 4/21/97	4h	0%	2.11d				
36	Leak Check Control, Cal, Ref, Wall Sys (if required) & Arc Sector Lines	Mon 4/21/97	Tue 4/22/97	2h	0%	2.11d				
37	Perform Instrumentation Checkout	Tue 4/22/97	Tue 4/22/97	4h	0%	2.11d				
38	Hand Load Balance & AOA Instrumentation	Tue 4/22/97	Tue 4/22/97	0.25h	0%	2.11d				
39	Perform Leak & Spot Check of Model Orifices	Tue 4/22/97	Tue 4/22/97	8h	0%	2.11d				
40	Install Flow Blocker Behind Roll Drive	Tue 4/22/97	Tue 4/22/97	0.5h	0%	2.11d				
41	Secure JB-16 Wiring & Tubing	Tue 4/22/97	Tue 4/22/97	1h	0%	2.11d				
42	Close JB-16	Tue 4/22/97	Tue 4/22/97	1h	0%	2.11d				
43	Install Leveling Plate and Pitch Pin Reading (pitch & roll)	Tue 4/22/97	Wed 4/23/97	4h	0%	2.11d				
44	Zero Roll Pot to Model	Wed 4/23/97	Wed 4/23/97	1h	0%	2.11d				
45	Model AOA & Bubble Calibration/Verification	Wed 4/23/97	Wed 4/23/97	1h	0%	2.11d				
46	Balance Dynamic Display Unit and Critical Point Analyzer Checkout	Wed 4/23/97	Wed 4/23/97	1h	0%	2.11d				
47	Data Acquisition System Under Configuration Control	Wed 4/23/97	Wed 4/23/97	0h	0%	2.11d				
48	Remove Leveling Plate & Plug Holes	Wed 4/23/97	Wed 4/23/97	1h	0%	2.11d				
49	Final Filling and Sanding of Model	Wed 4/23/97	Wed 4/23/97	4h	0%	2.11d				
50	Model Tare	Wed 4/23/97	Wed 4/23/97	1h	0%	2.11d				
51	Windo/UTPC Polar Check (upright & inverted)	Wed 4/23/97	Wed 4/23/97	1h	0%	2.11d				
52	<b>Tunnel Close Out Work Package</b>	Fri 4/25/97	Mon 4/28/97	0.44d	0%	0d				
53	Complete Close Out of Tunnel per IOP-106-A	Fri 4/25/97	Mon 4/28/97	4h	0%	0d				
54	Complete IOP 107-A	Mon 4/28/97	Mon 4/28/97	1h	0%	0d				
55	Micro "B" Arc Sector Verification	Mon 4/28/97	Mon 4/28/97	2h	0%	0d				
56	Complete Instrumentation Pre-test Checklist	Mon 4/28/97	Mon 4/28/97	0h	0%	0d				
57	<b>Tunnel and Model Ready For Test Operations</b>	Mon 4/28/97	Mon 4/28/97	0h	0%	0d				

Figure 6. NTF Model CI





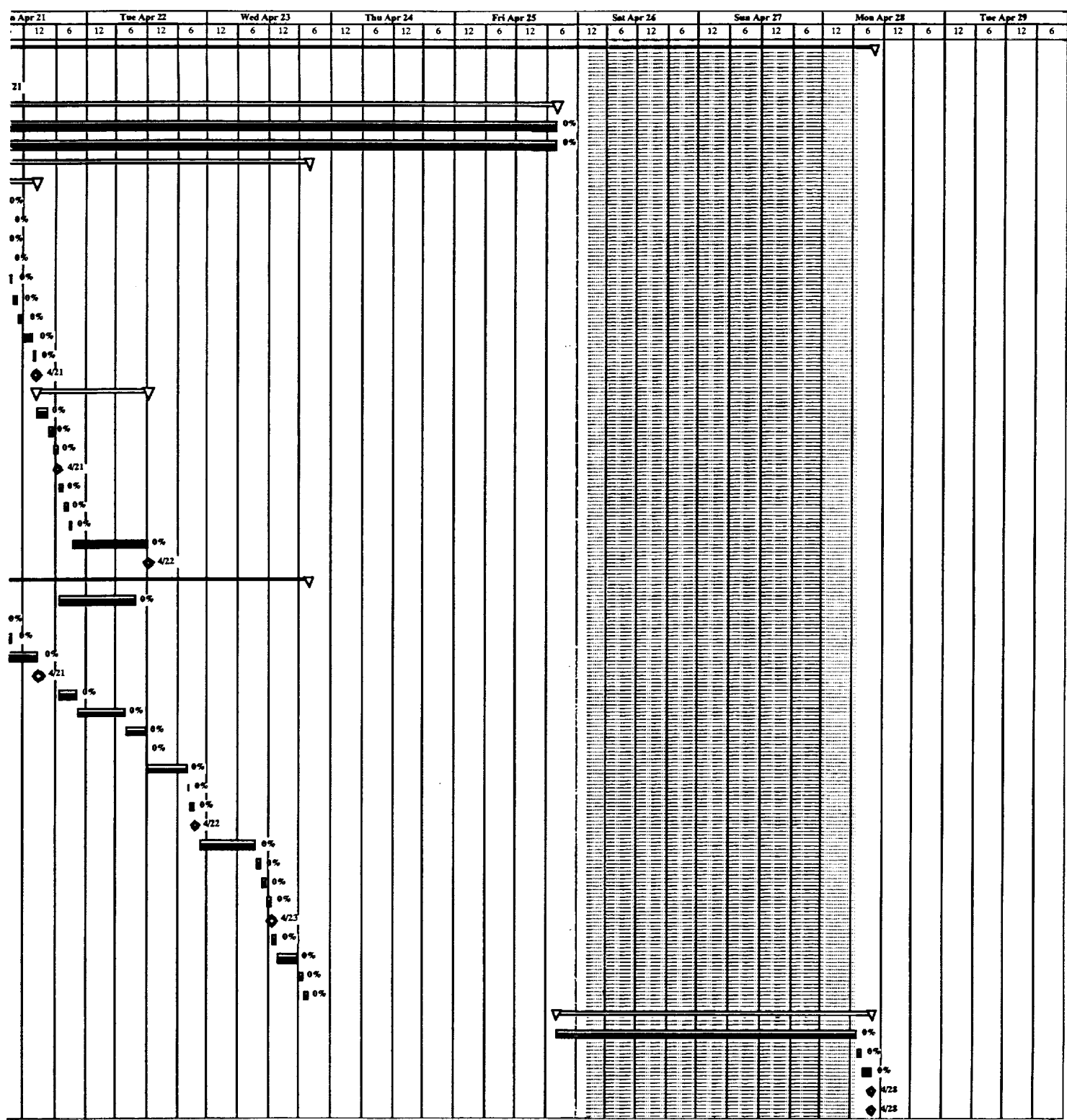

Handover Template.



ID	Task	Start	Finish	Duration	% Complete	Total Slack	Predecessor	Baseline Start	Baseline Finish	Baseline Duration
1	NTF Model Changeover	Mon 4/21/97	Mon 4/28/97	5.44d	0%	0d		Mon 4/21/97	Mon 4/28/97	5.44d
2	Previous Model Test Program	Mon 4/21/97	Mon 4/21/97	0h	0%	0d		Mon 4/21/97	Mon 4/21/97	0h
3	Tunnel Inspection and Maintenance Work	Mon 4/21/97	Mon 4/21/97	0h	0%	0d		Mon 4/21/97	Mon 4/21/97	0h
4	Tunnel	Mon 4/21/97	Mon 4/21/97	0h	0%	0d		Mon 4/21/97	Mon 4/21/97	0h
5	Model and Instrumentation Work	Mon 4/21/97	Mon 4/21/97	0h	0%	0d		Mon 4/21/97	Mon 4/21/97	0h
6	Previous Model	Mon 4/21/97	Mon 4/21/97	0h	0%	0d		Mon 4/21/97	Mon 4/21/97	0h
7	Open JB-16	Mon 4/21/97	Mon 4/21/97	0.47d	0%	2.11d		Mon 4/21/97	Mon 4/21/97	0.47d
8	Disconnect Model Wiring & Secure to 3rd	Mon 4/21/97	Mon 4/21/97	1h	0%	2.17d		Mon 4/21/97	Mon 4/21/97	1h
9	Install Ramp & Floor	Mon 4/21/97	Mon 4/21/97	1h	0%	2.17d		Mon 4/21/97	Mon 4/21/97	1h
10	Remove Model Sling From Stub Sling & Secure to	Mon 4/21/97	Mon 4/21/97	1h	0%	2.11d		Mon 4/21/97	Mon 4/21/97	1h
11	Move NS Access Housing From Arc Sector & Move to	Mon 4/21/97	Mon 4/21/97	1h	0%	2.11d		Mon 4/21/97	Mon 4/21/97	1h
12	Remove Stub Sling From Arc Sector & Move to	Mon 4/21/97	Mon 4/21/97	1h	0%	2.11d		Mon 4/21/97	Mon 4/21/97	1h
13	Remove Access Housing	Mon 4/21/97	Mon 4/21/97	1h	0%	2.11d		Mon 4/21/97	Mon 4/21/97	1h
14	Previous Model	Mon 4/21/97	Mon 4/21/97	0.5h	0%	2.11d		Mon 4/21/97	Mon 4/21/97	0.5h
15	Model Installation	Mon 4/21/97	Mon 4/21/97	0h	0%	2.11d		Mon 4/21/97	Mon 4/21/97	0h
16	Move & Mount Stub Sling to Arc	Mon 4/21/97	Mon 4/21/97	0.81d	0%	2.11d		Mon 4/21/97	Mon 4/21/97	0.81d
17	Move Model From Shop to Test	Mon 4/21/97	Mon 4/21/97	2h	0%	2.11d		Mon 4/21/97	Mon 4/21/97	2h
18	Secure Model Sling to Stub	Mon 4/21/97	Mon 4/21/97	1h	0%	2.11d		Mon 4/21/97	Mon 4/21/97	1h
19	Model	Mon 4/21/97	Mon 4/21/97	1h	0%	2.11d		Mon 4/21/97	Mon 4/21/97	1h
20	Move Empty Cart to	Mon 4/21/97	Mon 4/21/97	0h	0%	2.11d		Mon 4/21/97	Mon 4/21/97	0h
21	Remove Ramp & Floor	Mon 4/21/97	Mon 4/21/97	1h	0%	3.63d		Mon 4/21/97	Mon 4/21/97	1h
22	Move NS Access Housing From 3rd Floor to Vapor	Mon 4/21/97	Mon 4/21/97	1h	0%	3.63d		Mon 4/21/97	Mon 4/21/97	1h
23	Fit Access Housing	Mon 4/21/97	Mon 4/21/97	1h	0%	3.63d		Mon 4/21/97	Mon 4/21/97	1h
24	Model Installation	Mon 4/21/97	Mon 4/21/97	7.5h	0%	3.63d		Mon 4/21/97	Mon 4/21/97	7.5h
25	Instrumentation Installation/Checkout and Final Model	Mon 4/21/97	Mon 4/21/97	0h	0%	3.63d		Mon 4/21/97	Mon 4/21/97	0h
26	Video Camera Setup & Calibration (wing twist & TSP tasks not	Mon 4/21/97	Mon 4/21/97	2.84d	0%	3.63d		Mon 4/21/97	Mon 4/21/97	2.84d
27	Tunnel Patchboard Installation &	Mon 4/21/97	Mon 4/21/97	8h	0%	3.18d		Mon 4/21/97	Mon 4/21/97	8h
28	Configuration of Tubing per AIP.	Mon 4/21/97	Mon 4/21/97	1h	0%	2.88d		Mon 4/21/97	Mon 4/21/97	1h
29	Set Up Deck & Data Reduction	Mon 4/21/97	Mon 4/21/97	2h	0%	2.88d		Mon 4/21/97	Mon 4/21/97	2h
30	Data Acquisition Systems Ready to Take	Mon 4/21/97	Mon 4/21/97	8h	0%	2.58d		Mon 4/21/97	Mon 4/21/97	8h
31	Connect Model Wiring & Tubing at JB	Mon 4/21/97	Mon 4/21/97	0h	0%	2.58d		Mon 4/21/97	Mon 4/21/97	0h
32	Leak Check Control, Cal, Ref, Wall Sys (if required) & Arc Sector	Mon 4/21/97	Mon 4/21/97	4h	0%	2.11d		Mon 4/21/97	Mon 4/21/97	4h
33	Perform Instrumentation	Mon 4/21/97	Mon 4/21/97	2h	0%	2.11d		Mon 4/21/97	Mon 4/21/97	2h
34	Hand Load Balances & AOA	Mon 4/21/97	Mon 4/21/97	4h	0%	2.11d		Mon 4/21/97	Mon 4/21/97	4h
35	Perform Leak & Spot Check of Model	Mon 4/21/97	Mon 4/21/97	0.25h	0%	2.11d		Mon 4/21/97	Mon 4/21/97	0.25h
36	Install Flow Recorder Behind Roll	Mon 4/21/97	Mon 4/21/97	8h	0%	2.11d		Mon 4/21/97	Mon 4/21/97	8h
37	Secure JB-16 Wiring &	Mon 4/21/97	Mon 4/21/97	0.5h	0%	2.11d		Mon 4/21/97	Mon 4/21/97	0.5h
38	Close JB	Mon 4/21/97	Mon 4/21/97	1h	0%	2.11d		Mon 4/21/97	Mon 4/21/97	1h
39	Install Leveling Plate and Pitch Pin Reading (pitch &	Mon 4/21/97	Mon 4/21/97	4h	0%	2.11d		Mon 4/21/97	Mon 4/21/97	4h
40	Zero Roll Pot to	Mon 4/21/97	Mon 4/21/97	1h	0%	2.11d		Mon 4/21/97	Mon 4/21/97	1h
41	Model AOA & Bubble	Mon 4/21/97	Mon 4/21/97	1h	0%	2.11d		Mon 4/21/97	Mon 4/21/97	1h
42	Balance Dynamic Display Unit and Critical Point Analyzer	Mon 4/21/97	Mon 4/21/97	1h	0%	2.11d		Mon 4/21/97	Mon 4/21/97	1h
43	Data Acquisition Systems Under Configuration	Mon 4/21/97	Mon 4/21/97	0h	0%	2.11d		Mon 4/21/97	Mon 4/21/97	0h
44	Remove Leveling Plate & Plug	Mon 4/21/97	Mon 4/21/97	1h	0%	2.11d		Mon 4/21/97	Mon 4/21/97	1h
45	Final Filling and Sanding of	Mon 4/21/97	Mon 4/21/97	4h	0%	2.11d		Mon 4/21/97	Mon 4/21/97	4h
46	Model Tare	Mon 4/21/97	Mon 4/21/97	4h	0%	2.11d		Mon 4/21/97	Mon 4/21/97	4h
47	Windoff/TPC Polar Check (upright) &	Mon 4/21/97	Mon 4/21/97	1h	0%	2.11d		Mon 4/21/97	Mon 4/21/97	1h
48	Complete Close Out of Tunnel per IOP-	Mon 4/21/97	Mon 4/21/97	1h	0%	2.11d		Mon 4/21/97	Mon 4/21/97	1h
49	Complete IOP 107-	Mon 4/21/97	Mon 4/21/97	0.44d	0%	0d		Mon 4/21/97	Mon 4/21/97	0.44d
50	Micro 'B' Arc Sector	Mon 4/21/97	Mon 4/21/97	4h	0%	0d		Mon 4/21/97	Mon 4/21/97	4h
51	Complete Instrumentation Pre-test	Mon 4/21/97	Mon 4/21/97	2h	0%	0d		Mon 4/21/97	Mon 4/21/97	2h
52	Tunnel and Model Ready For Test	Mon 4/21/97	Mon 4/21/97	0h	0%	0d		Mon 4/21/97	Mon 4/21/97	0h

Figure 7. Task predecessors.

□ □ □ □

□ □ □ □

□ □ □ □

□ □ □ □



ID	Task Name	Start	Finish	Duration	% Complete	Total Slack	The M
1	<b>NTF Model Changeover Process</b>	Thu 5/8/97	Thu 5/15/97	5.44d	0%	0d	6
2							
3	Previous Model Test Program Completed	Thu 5/8/97	Thu 5/8/97	0h	0%	0d	
4	<b>Tunnel Inspection and Maintenance Work Package</b>	Thu 5/8/97	Thu 5/15/97	5d	0%	0d	
5	Tunnel Inspections	Thu 5/8/97	Thu 5/15/97	5d	0%	0d	
6	Tunnel Maintenance	Thu 5/8/97	Thu 5/15/97	5d	0%	0d	
7	<b>Model and Instrumentation Work Package</b>	Mon 5/12/97	Thu 5/15/97	2.89d	0%	0d	
8	Previous Model Removal	Mon 5/12/97	Tue 5/13/97	0.47d	0%	0d	
9	Open JB-16	Mon 5/12/97	Mon 5/12/97	1h	0%	0d	
10	Disconnect Model Wiring & Tubing	Mon 5/12/97	Mon 5/12/97	1h	0%	0d	
11	Move NS Access Housing From Vapor Enclosure to 3rd Floor	Mon 5/12/97	Mon 5/12/97	1h	0%	0d	
12	Install Ramp & Floor Plates	Mon 5/12/97	Mon 5/12/97	1h	0%	0d	
13	Move Empty Cart to Test Section	Mon 5/12/97	Mon 5/12/97	1h	0%	0d	
14	Remove Model Sting From Stub Sting & Secure to Cart	Mon 5/12/97	Tue 5/13/97	1h	0%	0d	
15	Move Model From Test Section to Shop	Tue 5/13/97	Tue 5/13/97	1h	0%	0d	
16	Remove Stub Sting From Arc Sector & Move to Shop	Tue 5/13/97	Tue 5/13/97	2h	0%	0d	
17	Remove Access Housing Seals	Tue 5/13/97	Tue 5/13/97	0.5h	0%	0d	
18	Previous Model Removed	Tue 5/13/97	Tue 5/13/97	0h	0%	0d	
19	<b>Model Installation</b>	Tue 5/13/97	Thu 5/15/97	2.42d	0%	0d	
20	Move & Mount Stub Sting to Arc Sector	Tue 5/13/97	Tue 5/13/97	2h	0%	0d	
21	Move Model From Shop to Test Section	Tue 5/13/97	Tue 5/13/97	1h	0%	0d	
22	Secure Model Sting to Stub Sting	Tue 5/13/97	Tue 5/13/97	1h	0%	0d	
23	Model Installed	Tue 5/13/97	Tue 5/13/97	0h	0%	0d	
24	Move Empty Cart to Shop	Wed 5/14/97	Thu 5/15/97	1h	0%	0d	
25	Remove Ramp & Floor Plates	Thu 5/15/97	Thu 5/15/97	1h	0%	0d	
26	Move NS Access Housing From 3rd Floor to Vapor Enclosure	Thu 5/15/97	Thu 5/15/97	1h	0%	0d	
27	Fit Access Housing Seals	Thu 5/15/97	Thu 5/15/97	7.5h	0%	0d	
28	Model Installation Complete	Thu 5/15/97	Thu 5/15/97	0h	0%	0d	
29	<b>Instrumentation Installation/Checkout and Final Model Checkout</b>	Tue 5/13/97	Thu 5/15/97	2.42d	0%	0d	
30	Video Camera Setup & Calibration (wing twist & TSP tasks not included)	Thu 5/15/97	Thu 5/15/97	8h	0%	0d	
31	Tunnel Patchboard Installation & Verification	Tue 5/13/97	Tue 5/13/97	1h	0%	0d	
32	Configuration of Tubing per AIP-29.6	Tue 5/13/97	Tue 5/13/97	2h	0%	0d	
33	Set Up Deck & Data Reduction Verification	Tue 5/13/97	Tue 5/13/97	8h	0%	0d	
34	Data Acquisition System Ready to Take Data	Tue 5/13/97	Tue 5/13/97	0h	0%	0d	
35	Connect Model Wiring & Tubing at JB-16	Tue 5/13/97	Tue 5/13/97	4h	0%	0d	
36	Leak Check Control, Cal, Ref, Wall Sys (if required) & Arc Sector Lines	Tue 5/13/97	Tue 5/13/97	2h	0%	0d	
37	Perform Instrumentation Checkout	Tue 5/13/97	Wed 5/14/97	4h	0%	0d	
38	Hand Load Balance & AOA Instrumentation	Wed 5/14/97	Wed 5/14/97	0.25h	0%	0d	
39	Perform Leak & Spot Check of Model Orifices	Wed 5/14/97	Wed 5/14/97	8h	0%	0d	
40	Install Flow Blocker Behind Roll Drive	Wed 5/14/97	Wed 5/14/97	0.5h	0%	0d	
41	Secure JB-16 Wiring & Tubing	Wed 5/14/97	Wed 5/14/97	1h	0%	0d	
42	Close JB-16	Wed 5/14/97	Wed 5/14/97	1h	0%	0d	
43	Install Leveling Plate and Pitch Pin Reading (pitch & roll)	Wed 5/14/97	Wed 5/14/97	4h	0%	0d	
44	Zero Roll Pot to Model	Wed 5/14/97	Thu 5/15/97	1h	0%	0d	
45	Model AOA & Bubble Calibration/Verification	Thu 5/15/97	Thu 5/15/97	1h	0%	0d	
46	Balance Dynamic Display Unit and Critical Point Analyzer Checkout	Thu 5/15/97	Thu 5/15/97	1h	0%	0d	
47	Data Acquisition System Under Configuration Control	Thu 5/15/97	Thu 5/15/97	0h	0%	0d	
48	Remove Leveling Plate & Plug Holes	Thu 5/15/97	Thu 5/15/97	1h	0%	0d	
49	Final Filling and Sanding of Model	Thu 5/15/97	Thu 5/15/97	4h	0%	0d	
50	Model Tare	Thu 5/15/97	Thu 5/15/97	1h	0%	0d	
51	Window/TPC Polar Check (upright & inverted)	Thu 5/15/97	Thu 5/15/97	1h	0%	0d	
52	<b>Tunnel Close Out Work Package</b>	Thu 5/15/97	Thu 5/15/97	0.44d	0%	0d	
53	Complete Close Out of Tunnel per IOP-106-A	Thu 5/15/97	Thu 5/15/97	4h	0%	0d	
54	Complete IOP 107-A	Thu 5/15/97	Thu 5/15/97	1h	0%	0d	
55	Micro "B" Arc Sector Verification	Thu 5/15/97	Thu 5/15/97	2h	0%	0d	
56	Complete Instrumentation Pre-test Checklist	Thu 5/15/97	Thu 5/15/97	0h	0%	0d	
57	<b>Tunnel and Model Ready For Test Operations</b>	Thu 5/15/97	Thu 5/15/97	0h	0%	0d	

Figure 8. NTF Model C



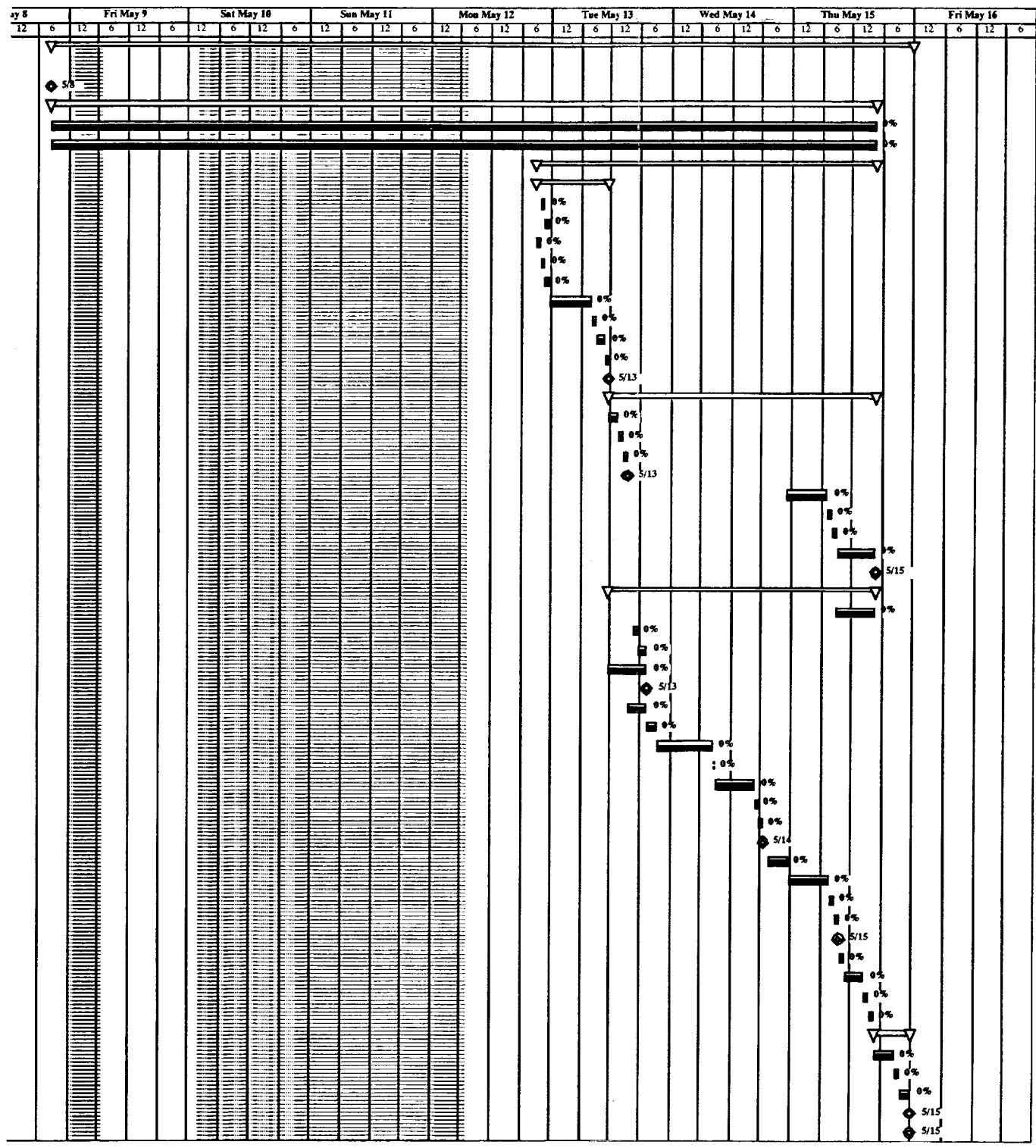

Changeover Template





ID	Task Name	Start	Finish	Duration	% Complete	Total Slack	Mon Apr 21		
							6	12	6
1	<b>NTF Model Changeover Process</b>	Mon 4/21/97	Tue 4/29/97	6.48d	45%	0d			
2									
3	<b>Previous Model Test Program Completed</b>	Mon 4/21/97	Mon 4/21/97	0h	0%	2.3d			
4	<b>Tunnel Inspection and Maintenance Work Package</b>	Mon 4/21/97	Mon 4/28/97	6.85d	38%	0d			
5	Tunnel Inspections	Mon 4/21/97	Fri 4/25/97	5d	50%	1.05d			
6	Tunnel Maintenance	Tue 4/22/97	Mon 4/28/97	5d	25%	0d			
7	<b>Model and Instrumentation Work Package</b>	Mon 4/21/97	Thu 4/24/97	4.08d	60%	1.97d			
8	<b>Previous Model Removal</b>	Mon 4/21/97	Mon 4/21/97	0.72d	100%	0d			
9	Open JB-16	Mon 4/21/97	Mon 4/21/97	1h	100%	0d			
10	Disconnect Model Wiring & Tubing	Mon 4/21/97	Mon 4/21/97	1h	100%	0d			
11	Move NS Access Housing From Vapor Enclosure to 3rd Floor	Mon 4/21/97	Mon 4/21/97	1h	100%	0d			
12	Install Ramp & Floor Plates	Mon 4/21/97	Mon 4/21/97	1h	100%	0d			
13	Move Empty Cart to Test Section	Mon 4/21/97	Mon 4/21/97	5h	100%	0d			
14	Remove Model Sting From Stub Sting & Secure to Cart	Mon 4/21/97	Mon 4/21/97	1h	100%	0d			
15	Move Model From Test Section to Shop	Mon 4/21/97	Mon 4/21/97	1h	100%	0d			
16	Remove Stub Sting From Arc Sector & Move to Shop	Mon 4/21/97	Mon 4/21/97	2h	100%	0d			
17	Remove Access Housing Seals	Mon 4/21/97	Mon 4/21/97	0.5h	100%	0d			
18	Previous Model Removed	Mon 4/21/97	Mon 4/21/97	0h	100%	0d			
19	<b>Model Installation</b>	Mon 4/21/97	Wed 4/23/97	1.84d	100%	0d			
20	Move & Mount Stub Sting to Arc Sector	Mon 4/21/97	Mon 4/21/97	2h	100%	0d			
21	Move Model From Shop to Test Section	Mon 4/21/97	Mon 4/21/97	1h	100%	0d			
22	Secure Model Sting to Stub Sting	Mon 4/21/97	Tue 4/22/97	1d	100%	0d			
23	Model Installed	Tue 4/22/97	Tue 4/22/97	0h	100%	0d			
24	Move Empty Cart to Shop	Tue 4/22/97	Tue 4/22/97	1h	100%	0d			
25	Remove Ramp & Floor Plates	Tue 4/22/97	Tue 4/22/97	1h	100%	0d			
26	Move NS Access Housing From 3rd Floor to Vapor Enclosure	Tue 4/22/97	Wed 4/23/97	1h	100%	0d			
27	Fit Access Housing Seals	Wed 4/23/97	Wed 4/23/97	7.5h	100%	0d			
28	Model Installation Complete	Wed 4/23/97	Wed 4/23/97	0h	100%	0d			
29	<b>Instrumentation Installation/Checkout and Final Model Checkout</b>	Mon 4/21/97	Thu 4/24/97	4.08d	35%	1.97d			
30	Video Camera Setup & Calibration (wing twist & TSP tasks not included)	Tue 4/22/97	Wed 4/23/97	8h	50%	3.64d			
31	Tunnel Patchboard Installation & Verification	Mon 4/21/97	Mon 4/21/97	1h	100%	0d			
32	Configuration of Tubing per AIP-29.6	Mon 4/21/97	Mon 4/21/97	2h	100%	0d			
33	Set Up Deck & Data Reduction Verification	Mon 4/21/97	Mon 4/21/97	8h	100%	0d			
34	Data Acquisition System Ready to Take Data	Mon 4/21/97	Mon 4/21/97	0h	100%	0d			
35	Connect Model Wiring & Tubing at JB-16	Tue 4/22/97	Wed 4/23/97	4h	100%	0d			
36	Leak Check Control, Cal, Ref, Wall Sys (if required) & Arc Sector Lines	Wed 4/23/97	Wed 4/23/97	2h	0%	1.97d			
37	Perform Instrumentation Checkout	Wed 4/23/97	Wed 4/23/97	4h	0%	1.97d			
38	Hand Load Balance & AOA Instrumentation	Wed 4/23/97	Wed 4/23/97	0.25h	0%	1.97d			
39	Perform Leak & Spot Check of Model Orifices	Wed 4/23/97	Wed 4/23/97	8h	0%	1.97d			
40	Install Flow Blocker Behind Roll Drive	Wed 4/23/97	Wed 4/23/97	0.5h	0%	1.97d			
41	Secure JB-16 Wiring & Tubing	Wed 4/23/97	Thu 4/24/97	1h	0%	1.97d			
42	Close JB-16	Thu 4/24/97	Thu 4/24/97	1h	0%	1.97d			
43	Install Leveling Plate and Fitch Pin Reading (pitch & roll)	Thu 4/24/97	Thu 4/24/97	4h	0%	1.97d			
44	Zero Roll Pot to Model	Thu 4/24/97	Thu 4/24/97	1h	0%	1.97d			
45	Model AOA & Bubbie Calibration/Verification	Thu 4/24/97	Thu 4/24/97	1h	0%	1.97d			
46	Balance Dynamic Display Unit and Critical Point Analyzer Checkout	Thu 4/24/97	Thu 4/24/97	1h	0%	1.97d			
47	Data Acquisition System Under Configuration Control	Thu 4/24/97	Thu 4/24/97	0h	0%	1.97d			
48	Remove Leveling Plate & Plug Holes	Thu 4/24/97	Thu 4/24/97	1h	0%	1.97d			
49	Final Filling and Sanding of Model	Thu 4/24/97	Thu 4/24/97	4h	0%	1.97d			
50	Model Tare	Thu 4/24/97	Thu 4/24/97	1h	0%	1.97d			
51	Windoff/TPC Polar Check (upright & inverted)	Thu 4/24/97	Thu 4/24/97	1h	0%	1.97d			
52	<b>Tunnel Close Out Work Package</b>	Mon 4/28/97	Tue 4/29/97	0.44d	0%	0d			
53	Complete Close Out of Tunnel per IOP-106-A	Mon 4/28/97	Tue 4/29/97	4h	0%	0d			
54	Complete IOP 107-A	Tue 4/29/97	Tue 4/29/97	1h	0%	0d			
55	Micro "B" Arc Sector Verification	Tue 4/29/97	Tue 4/29/97	2h	0%	0d			
56	Complete Instrumentation Pre-test Checklist	Tue 4/29/97	Tue 4/29/97	0h	0%	0d			
57	<b>Tunnel and Model Ready For Test Operations</b>	Tue 4/29/97	Tue 4/29/97	0h	0%	0d			

Figure 9. NTF Model C







ID	Task Name	Start	Finish	Mon Apr 21		Tue Apr 22	
				6	12	6	12
1	<u>NTF Model Changeover Process</u>	Mon 4/21/97	Mon 4/28/97				
2							
3	Previous Model Test Program Completed	Mon 4/21/97	Mon 4/21/97				
4	<u>Tunnel Inspection and Maintenance Work Package</u>	Mon 4/21/97	Fri 4/25/97				
5	Tunnel Inspections	Mon 4/21/97	Fri 4/25/97				
6	Tunnel Maintenance	Mon 4/21/97	Fri 4/25/97				
7	<u>Model and Instrumentation Work Package</u>	Mon 4/21/97	Wed 4/23/97				
8	Previous Model Removal	Mon 4/21/97	Mon 4/21/97				
9	Open JB-16	Mon 4/21/97	Mon 4/21/97				
10	Disconnect Model Wiring & Tubing	Mon 4/21/97	Mon 4/21/97				
11	Move NS Access Housing From Vapor Enclosure to 3rd Floor	Mon 4/21/97	Mon 4/21/97				
12	Install Ramp & Floor Plates	Mon 4/21/97	Mon 4/21/97				
13	Move Empty Cart to Test Section	Mon 4/21/97	Mon 4/21/97				
14	Remove Model Sting From Sub Sting & Secure to Cart	Mon 4/21/97	Mon 4/21/97				
15	Move Model From Test Section to Shop	Mon 4/21/97	Mon 4/21/97				
16	Remove Sub Sting From Arc Sector & Move to Shop	Mon 4/21/97	Mon 4/21/97				
17	Remove Access Housing Seals	Mon 4/21/97	Mon 4/21/97				
18	Previous Model Removed	Mon 4/21/97	Mon 4/21/97				
19	Model Installation	Mon 4/21/97	Tue 4/22/97				
20	Move & Mount Sub Sting to Arc Sector	Mon 4/21/97	Mon 4/21/97				
21	Move Model From Shop to Test Section	Mon 4/21/97	Mon 4/21/97				
22	Secure Model Sting to Sub Sting	Mon 4/21/97	Mon 4/21/97				
23	Model Installed	Mon 4/21/97	Mon 4/21/97				
24	Move Empty Cart to Shop	Mon 4/21/97	Mon 4/21/97				
25	Remove Ramp & Floor Plates	Mon 4/21/97	Mon 4/21/97				
26	Move NS Access Housing From 3rd Floor to Vapor Enclosure	Mon 4/21/97	Mon 4/21/97				
27	Fit Access Housing Seals	Mon 4/21/97	Tue 4/22/97				
28	Model Installation Complete	Tue 4/22/97	Tue 4/22/97				
29	Instrumentation Installation/Checkout and Final Model Checkout	Mon 4/21/97	Wed 4/23/97				
30	Video Camera Setup & Calibration (wing twist & TSP tasks not included)	Mon 4/21/97	Tue 4/22/97				
31	Tunnel Patchboard Installation & Verification	Mon 4/21/97	Mon 4/21/97				
32	Configuration of Tubing per AJP-29.6	Mon 4/21/97	Mon 4/21/97				
33	Set Up Deck & Data Reduction Verification	Mon 4/21/97	Mon 4/21/97				
34	Data Acquisition System Ready to Take Data	Mon 4/21/97	Mon 4/21/97				
35	Connect Model Wiring & Tubing at JB-16	Mon 4/21/97	Mon 4/21/97				
36	Leak Check Control, Cal, Ref, Wall Sys (if required) & Arc Sector Lines	Mon 4/21/97	Tue 4/22/97				
37	Perform Instrumentation Checkout	Tue 4/22/97	Tue 4/22/97				
38	Head Load Balance & AOA Instrumentation	Tue 4/22/97	Tue 4/22/97				
39	Perform Leak & Spot Check of Model Orifices	Tue 4/22/97	Tue 4/22/97				
40	Install Flow Blocker Behind Roll Drive	Tue 4/22/97	Tue 4/22/97				
41	Secure JB-16 Wiring & Tubing	Tue 4/22/97	Tue 4/22/97				
42	Close JB-16	Tue 4/22/97	Tue 4/22/97				
43	Install Leveling Plate and Pitch Pin Reading (pitch & roll)	Tue 4/22/97	Wed 4/23/97				
44	Zero Roll Pot to Model	Wed 4/23/97	Wed 4/23/97				
45	Model AOA & Bubble Calibration/Verification	Wed 4/23/97	Wed 4/23/97				
46	Balance Dynamic Display Unit and Critical Point Analyzer Checkout	Wed 4/23/97	Wed 4/23/97				
47	Data Acquisition System Under Configuration Control	Wed 4/23/97	Wed 4/23/97				
48	Remove Leveling Plate & Plug Holes	Wed 4/23/97	Wed 4/23/97				
49	Final Filling and Sanding of Model	Wed 4/23/97	Wed 4/23/97				
50	Model Tare	Wed 4/23/97	Wed 4/23/97				
51	Window/TPC Polar Check (upright & inverted)	Wed 4/23/97	Wed 4/23/97				
52	<u>Tunnel Close Out Work Package</u>	Fri 4/25/97	Mon 4/28/97				
53	Complete Close Out of Tunnel per IOP-106-A	Fri 4/25/97	Mon 4/28/97				
54	Complete IOP 107-A	Mon 4/28/97	Mon 4/28/97				
55	Micro "B" Arc Sector Verification	Mon 4/28/97	Mon 4/28/97				
56	Complete Instrumentation Pre-test Checklist	Mon 4/28/97	Mon 4/28/97				
57	Tunnel and Model Ready For Test Operations	Mon 4/28/97	Mon 4/28/97				

Figure 10. NTF Model C









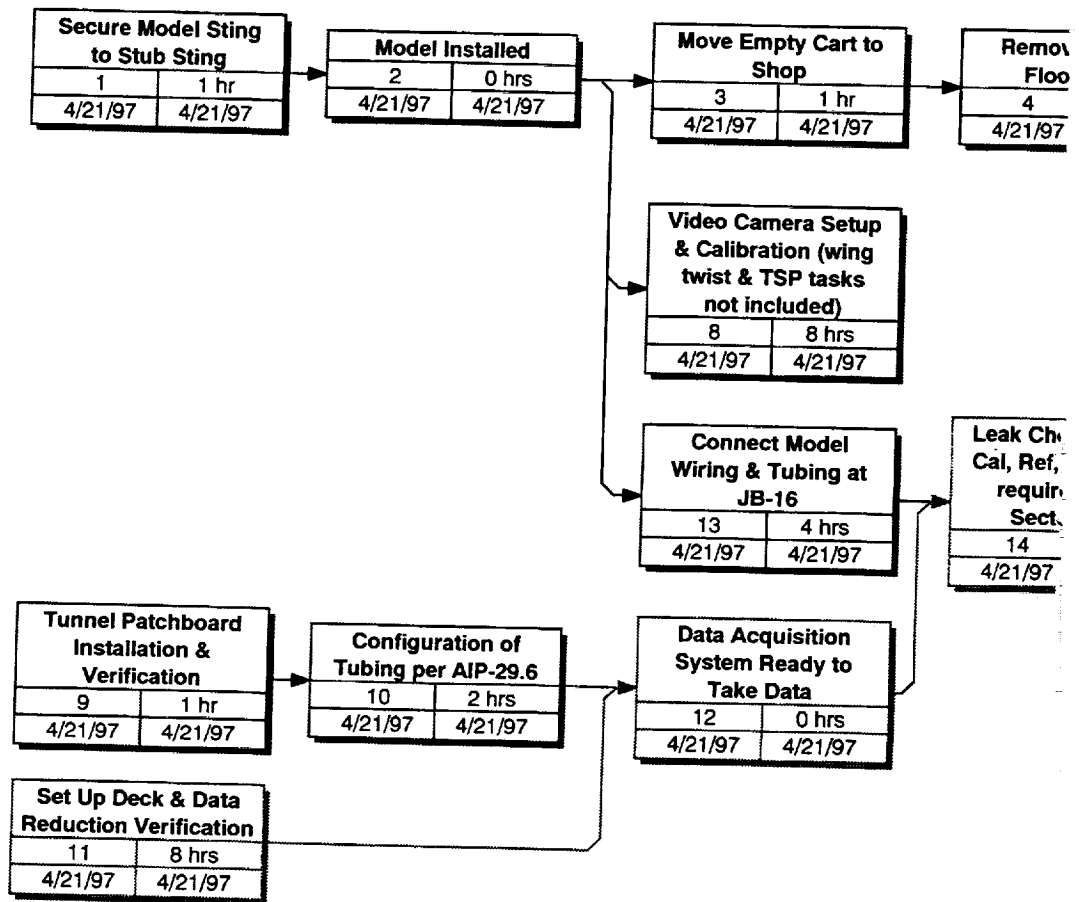
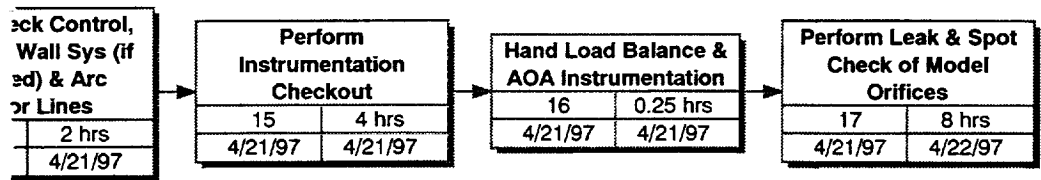
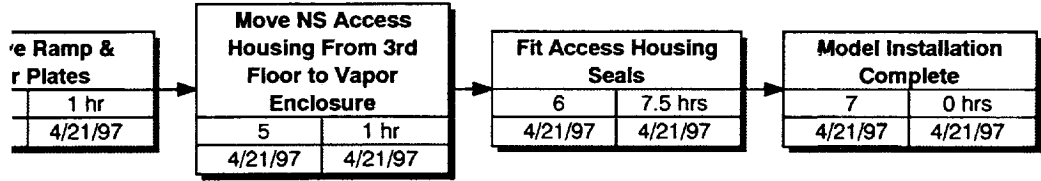

Figure 11. P





ERT Chart.



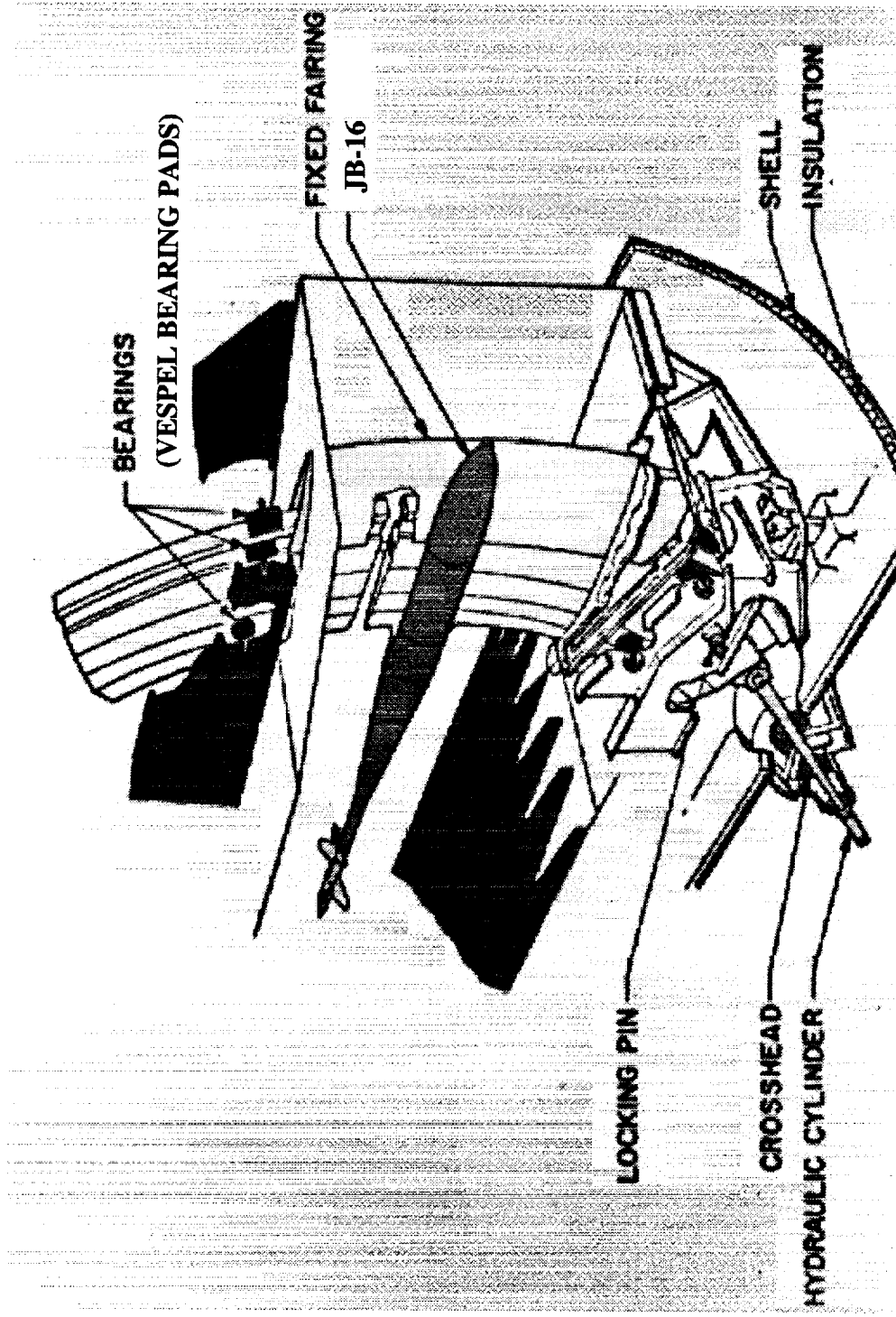

Figure 12. Model Support System.

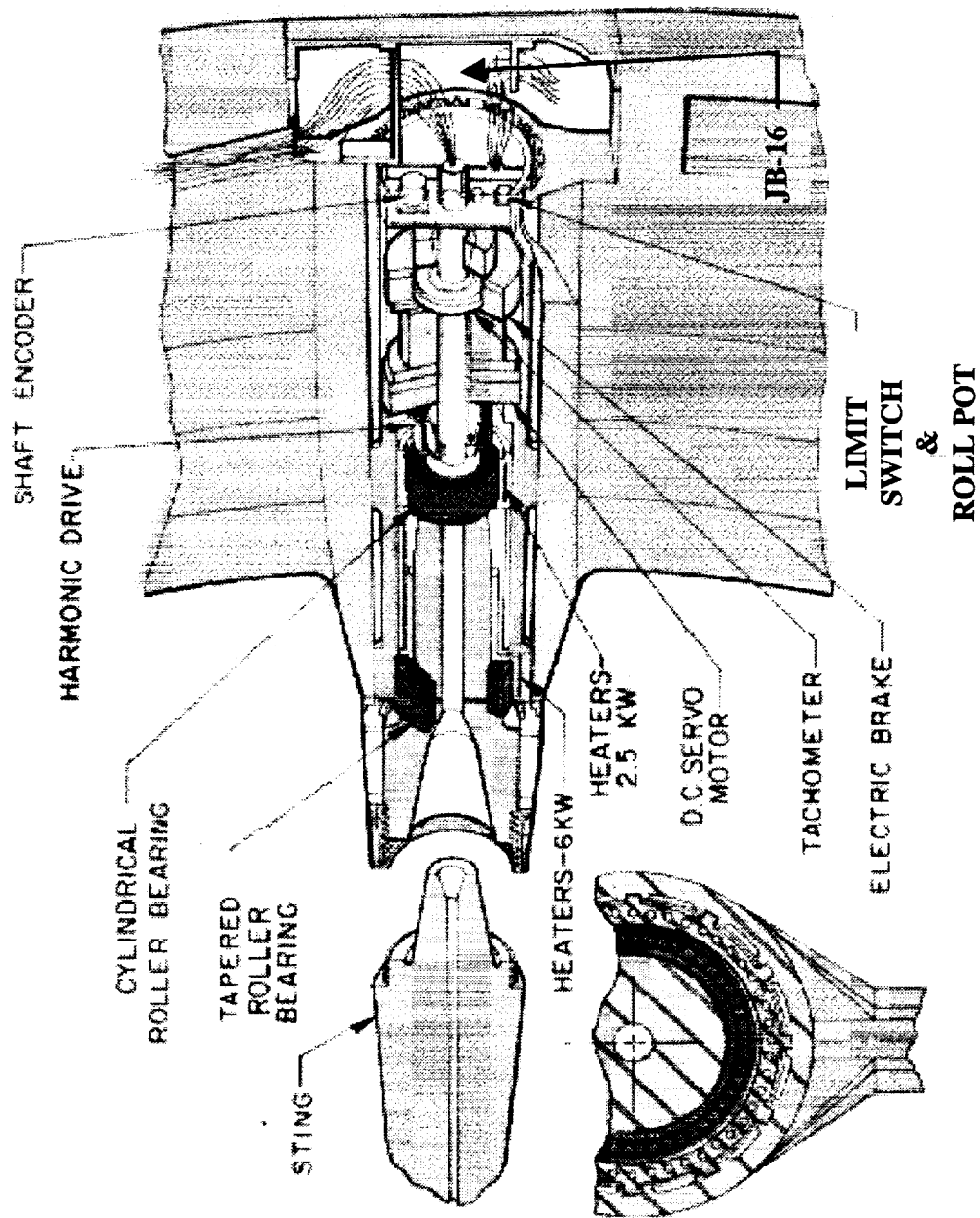

Figure 13. Roll Drive System.

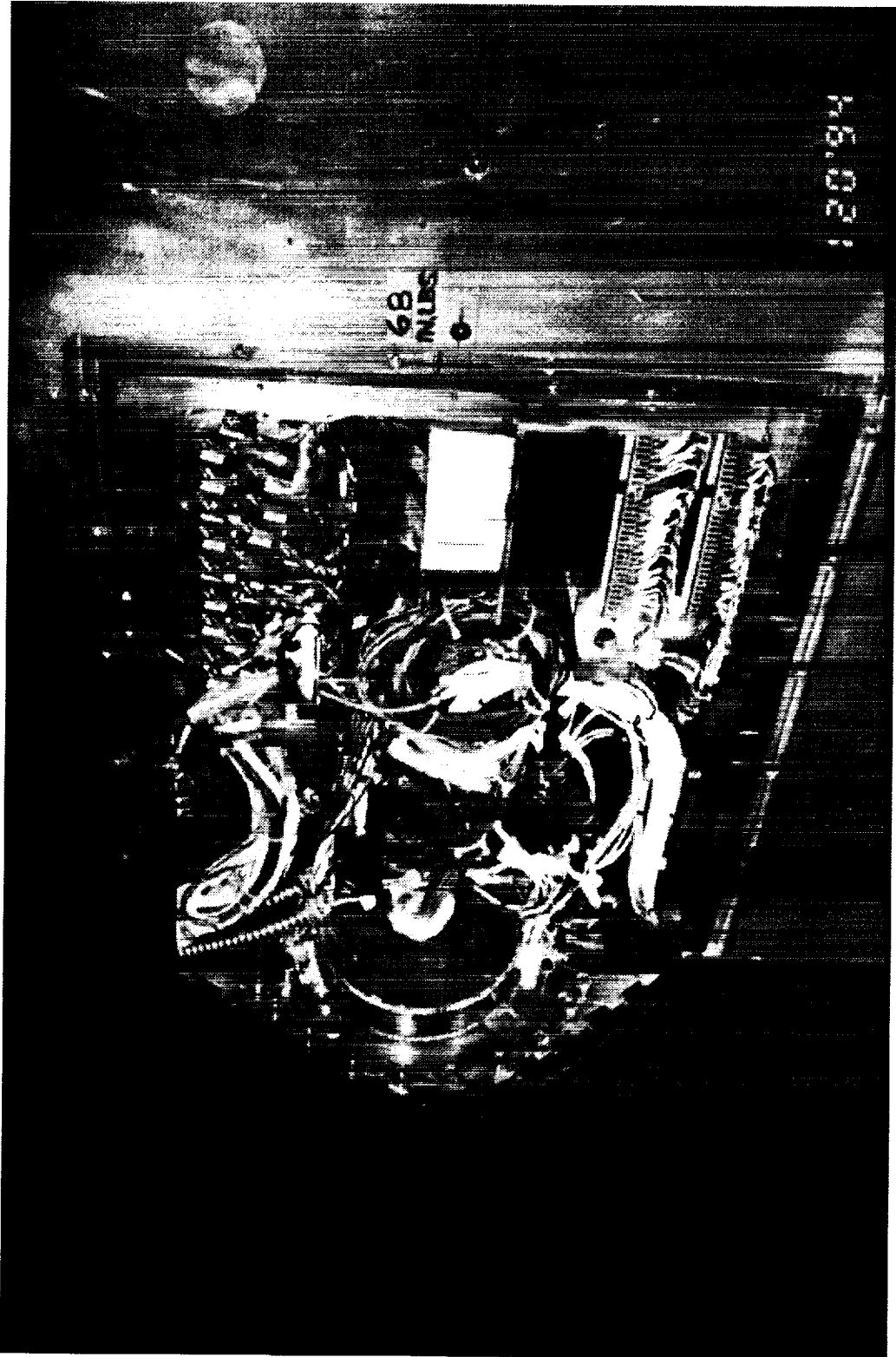

Figure 14. JB-16.

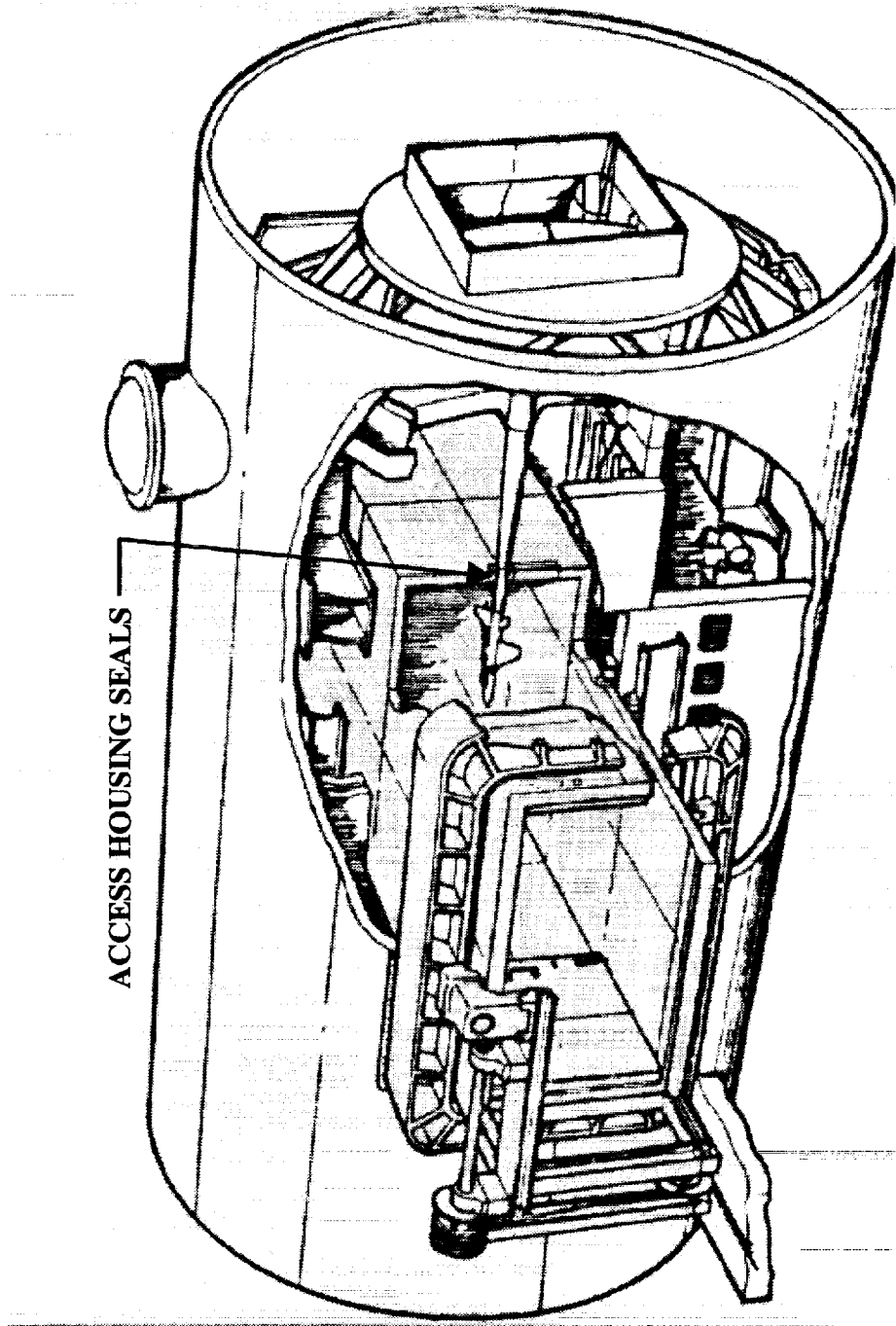

Figure 15. Model Access System.



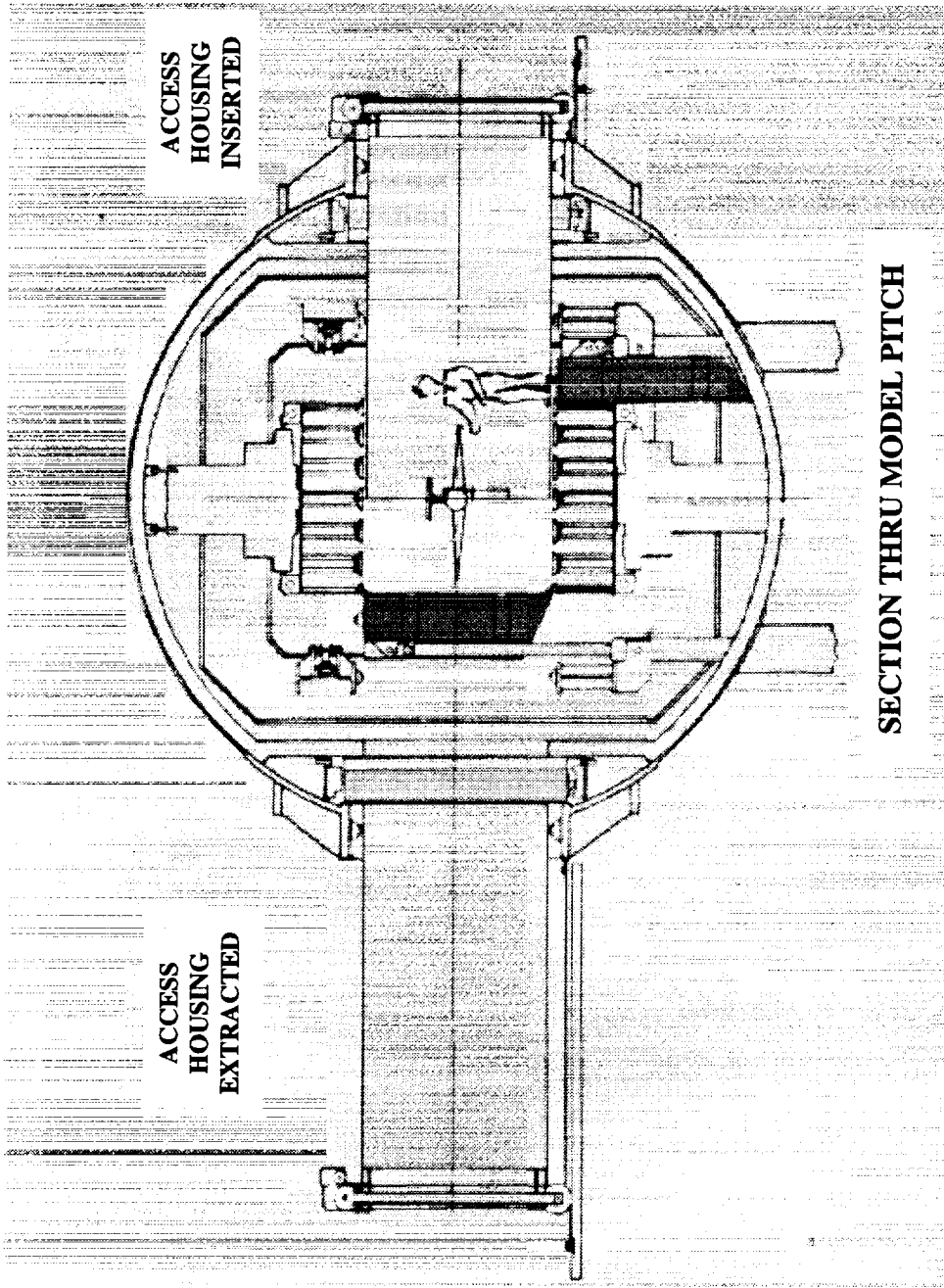
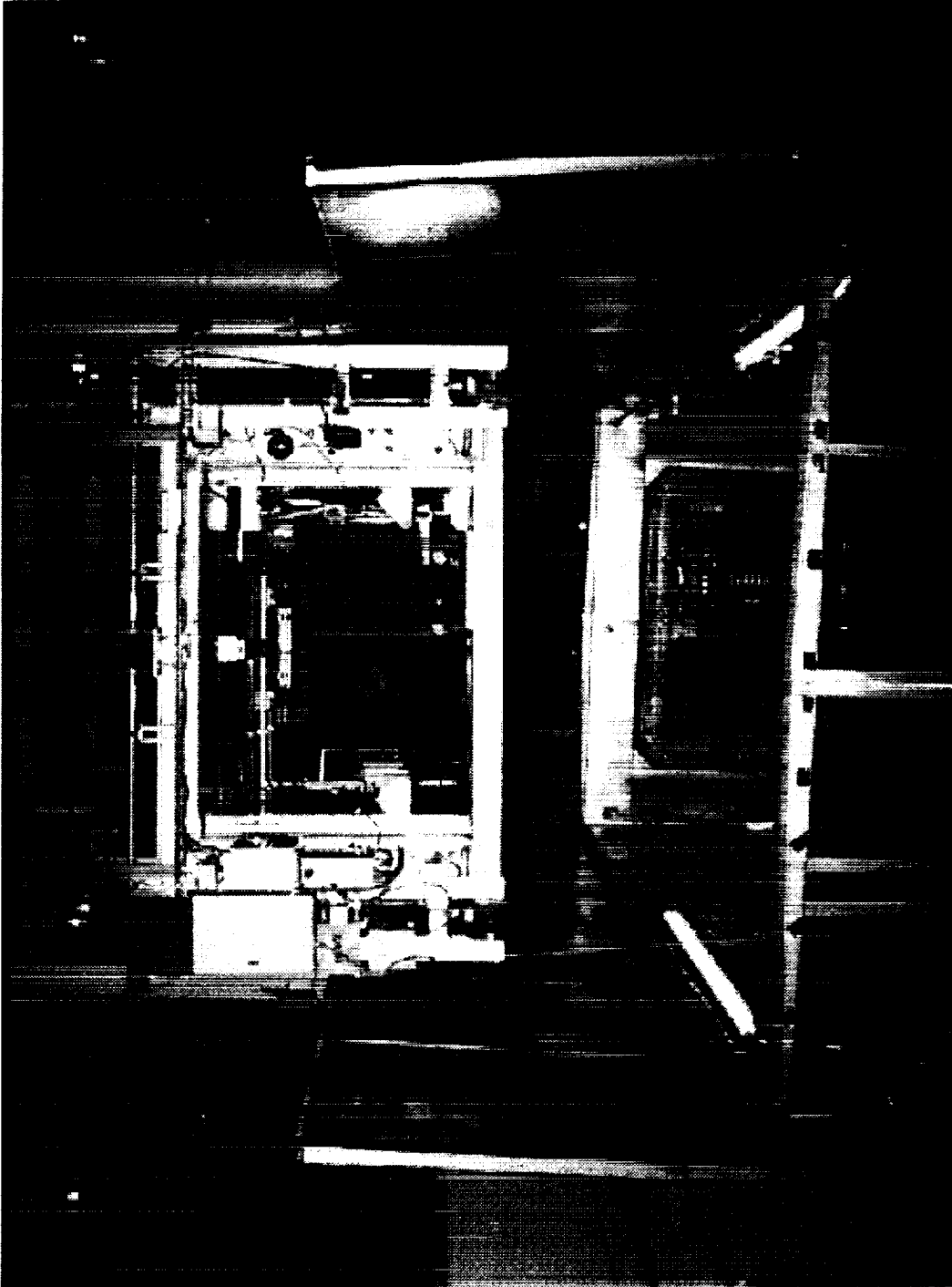

Figure 16. Model Access System.



**Figure 17.** Access Housing closest to the NTF's control room being lifted by overhead crane.

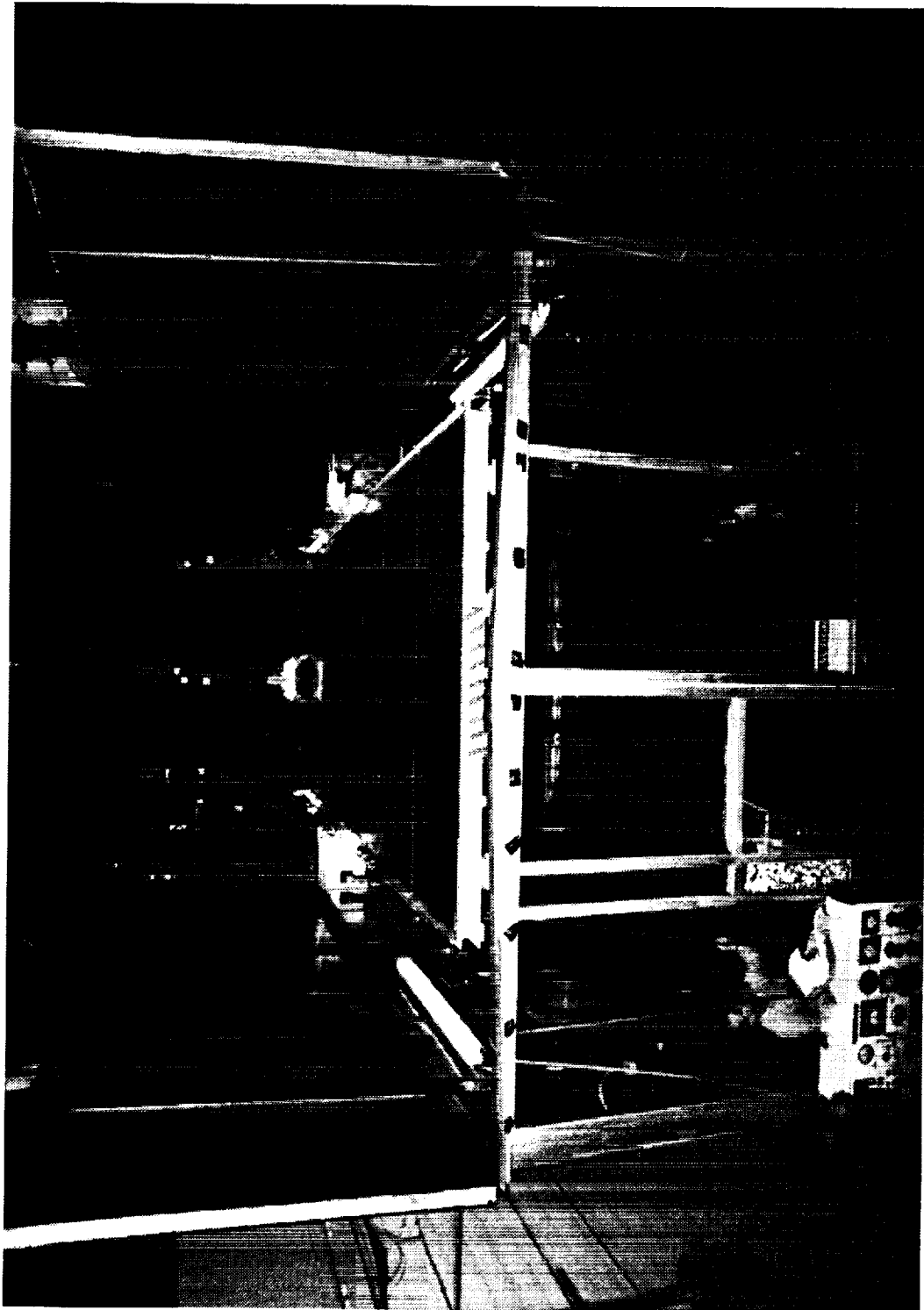
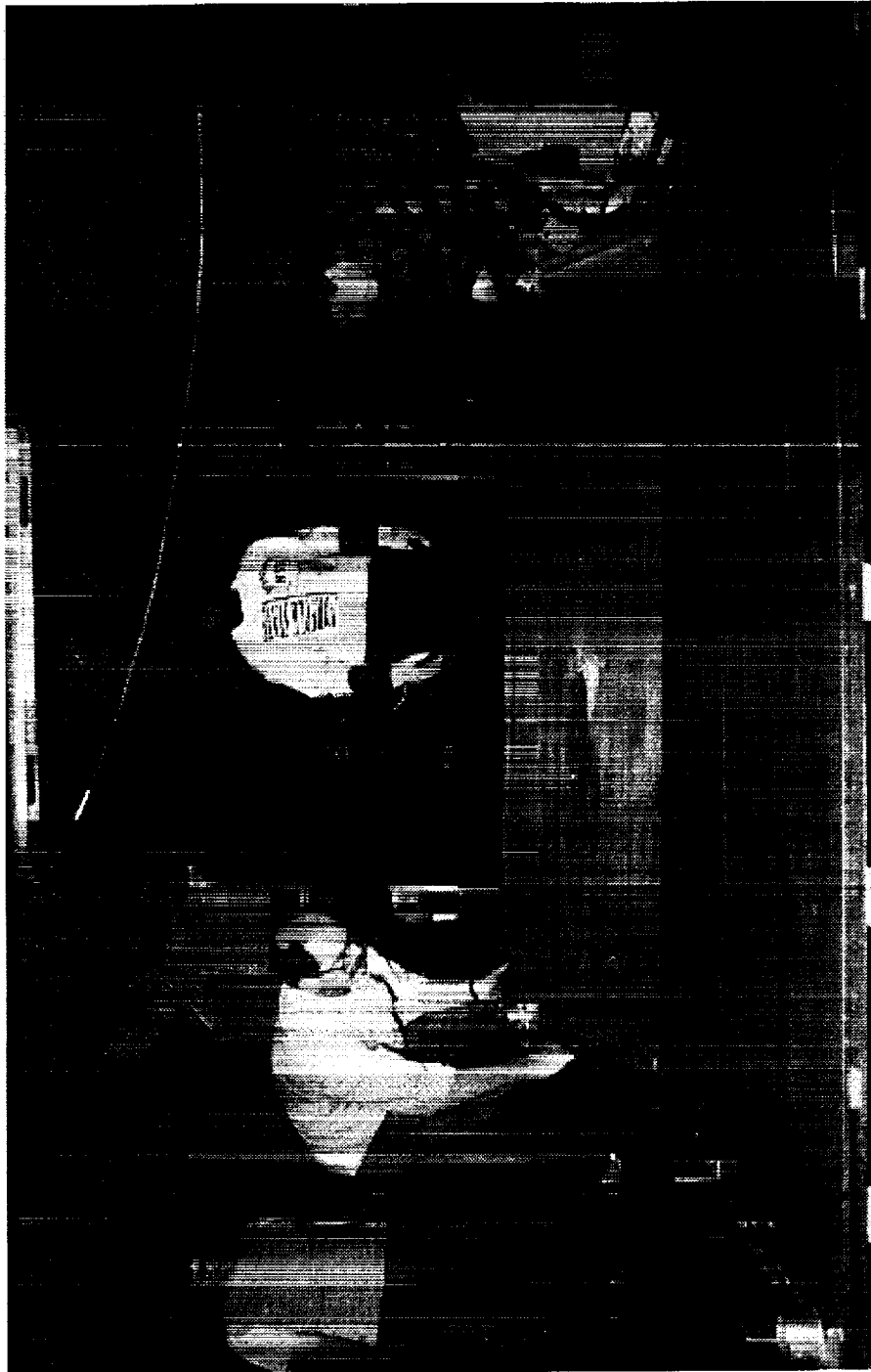
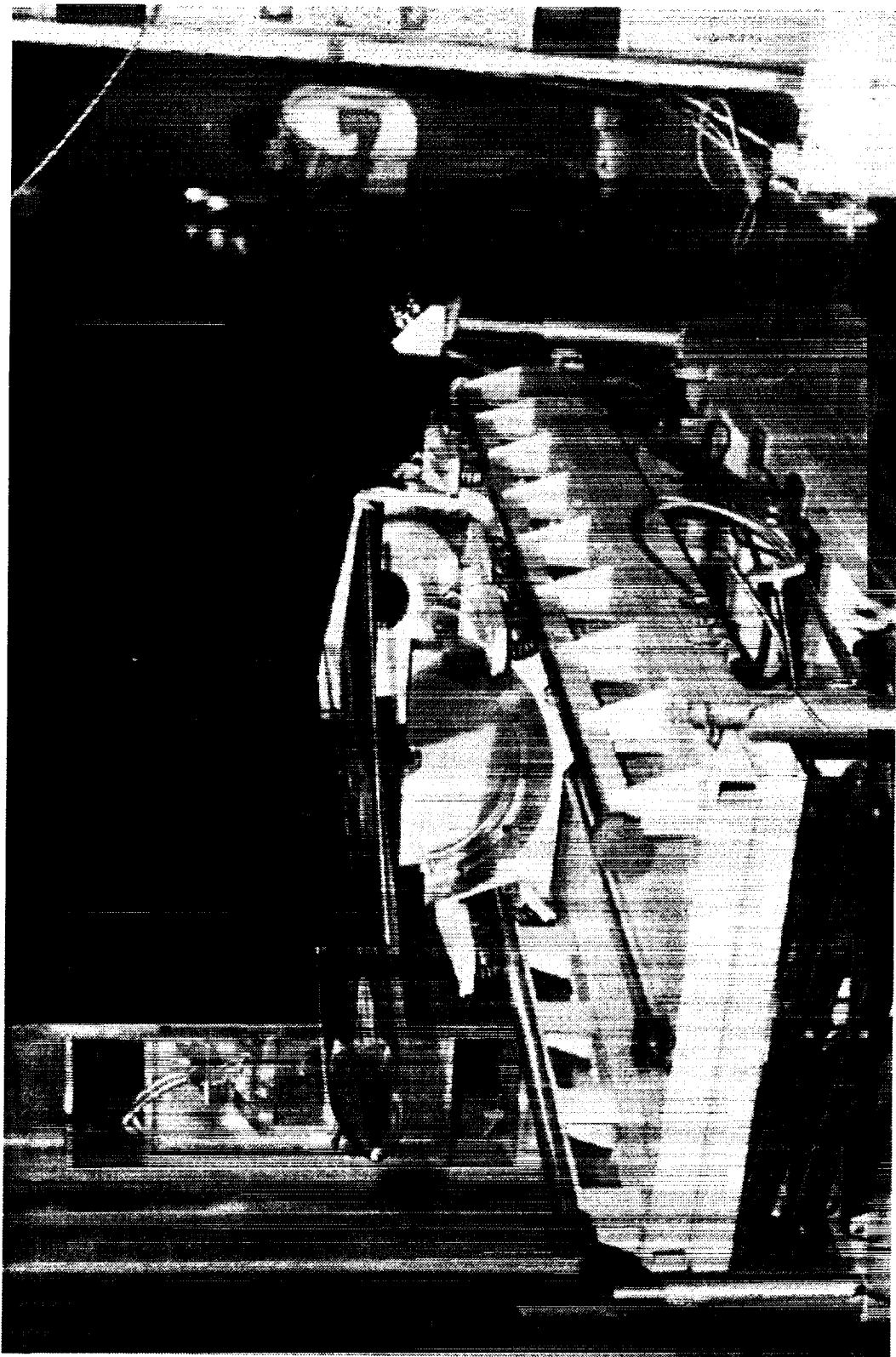

Figure 18. Ramp being lowered into position.



**Figure 19. Installation of test section floor plates.**



**Figure 20. Model Handling Cart in position.**

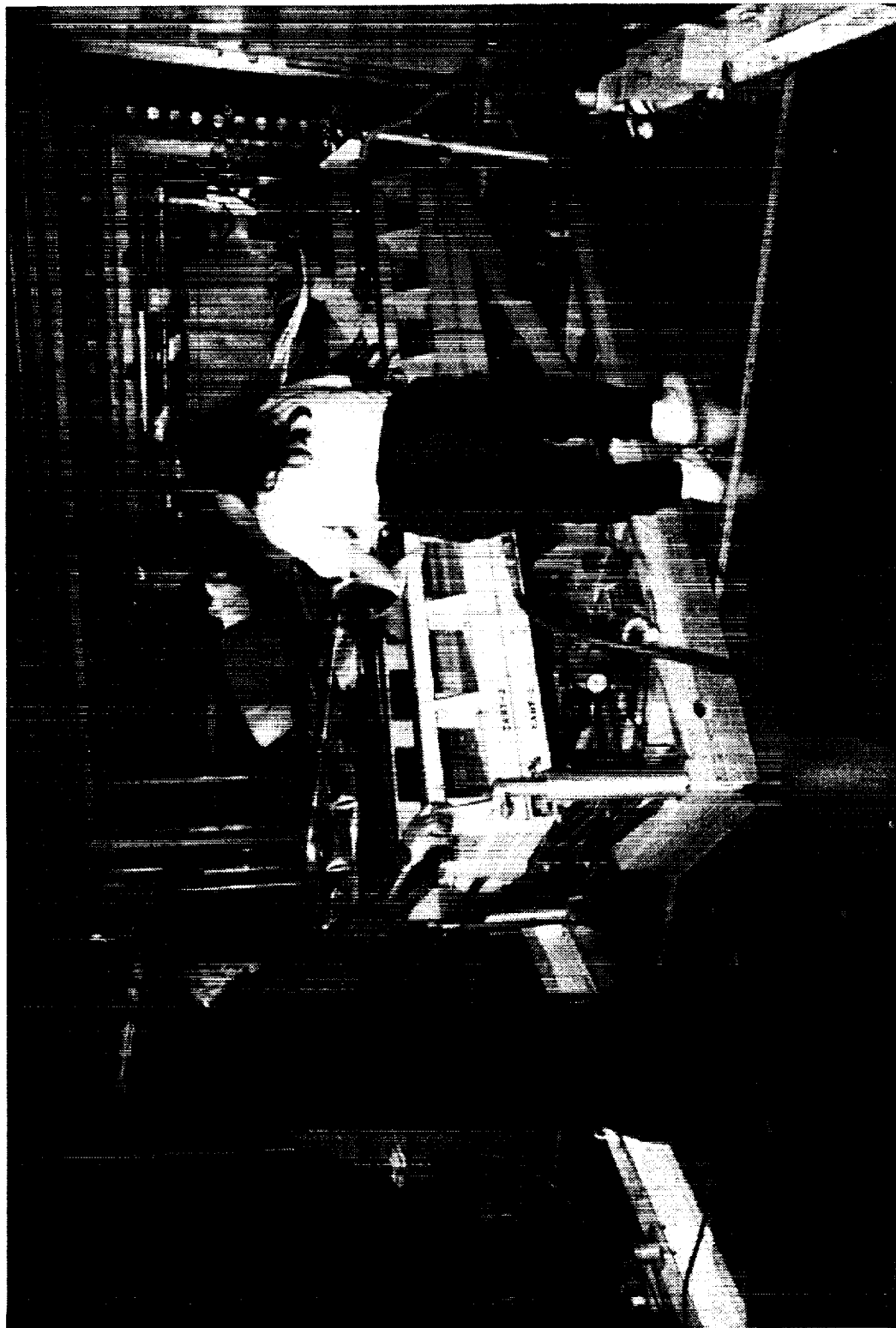
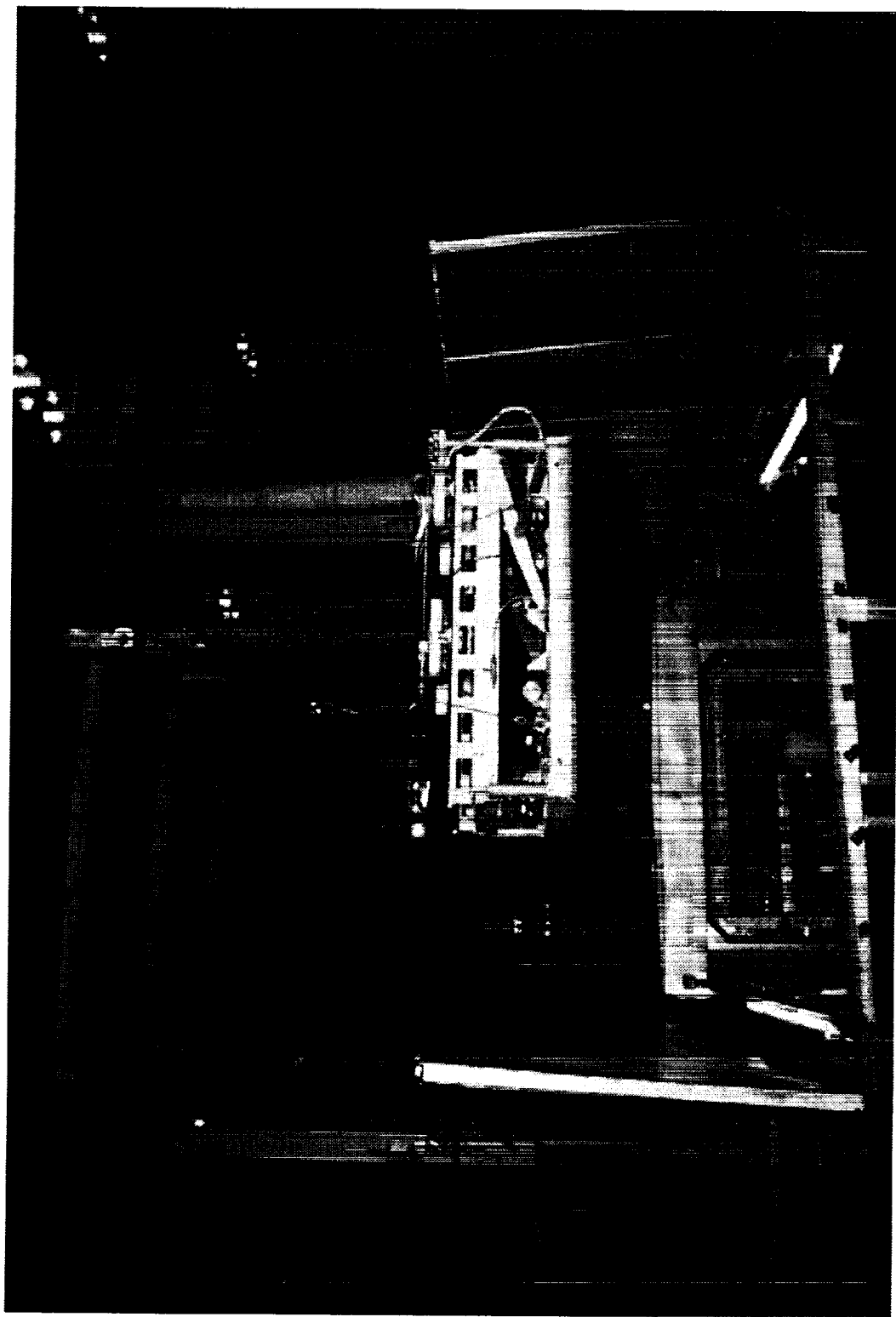

Figure 21. Transporting model and sting on model handling cart.



**Figure 22. Removing model handling cart through greenhouse closest to the NTF's control room.**



**Figure 23. Lowering model handling cart to first floor.**



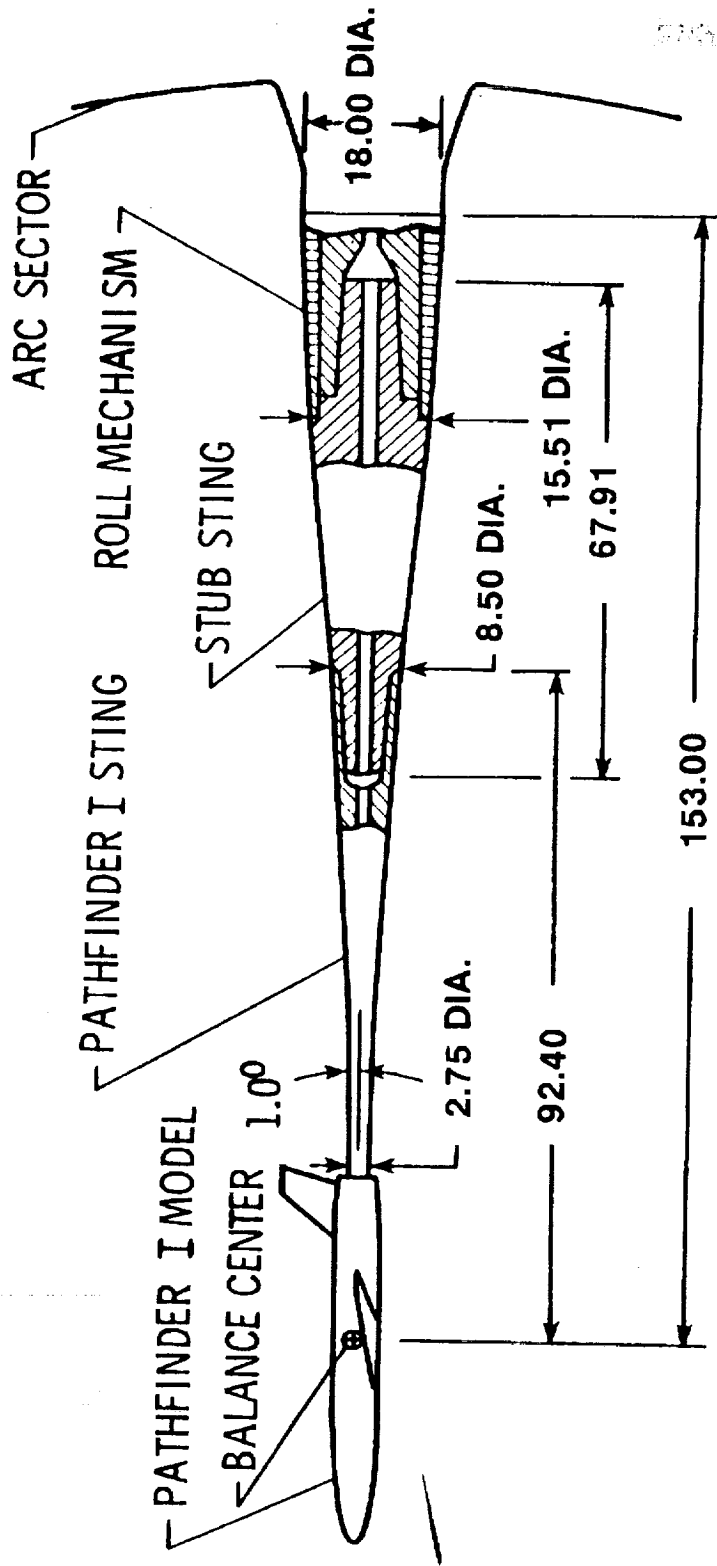

Figure 24. Sting configuration for 3D models. All dimensions are in inches.



Figure 25. Stub sting on model handling cart.

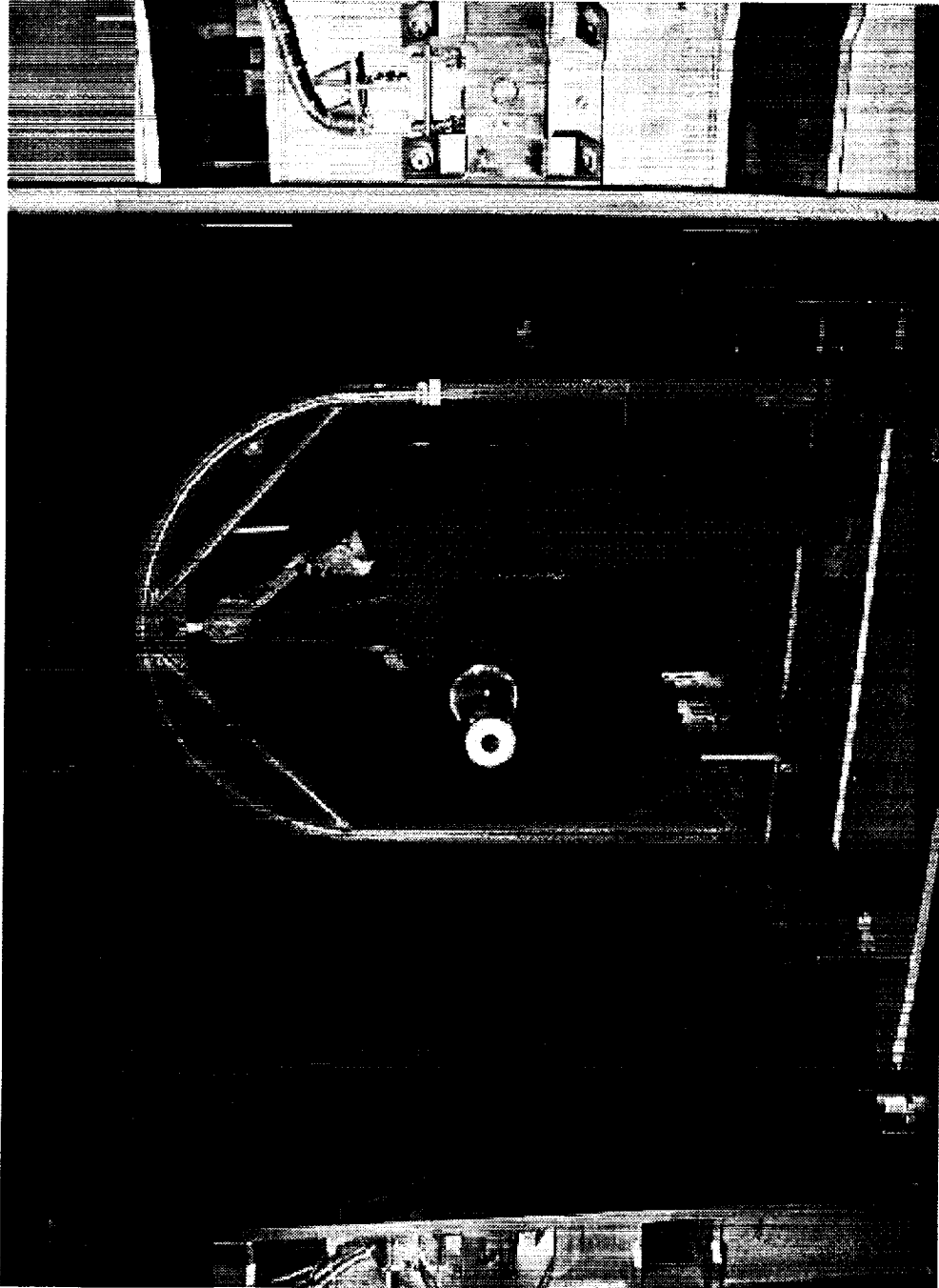
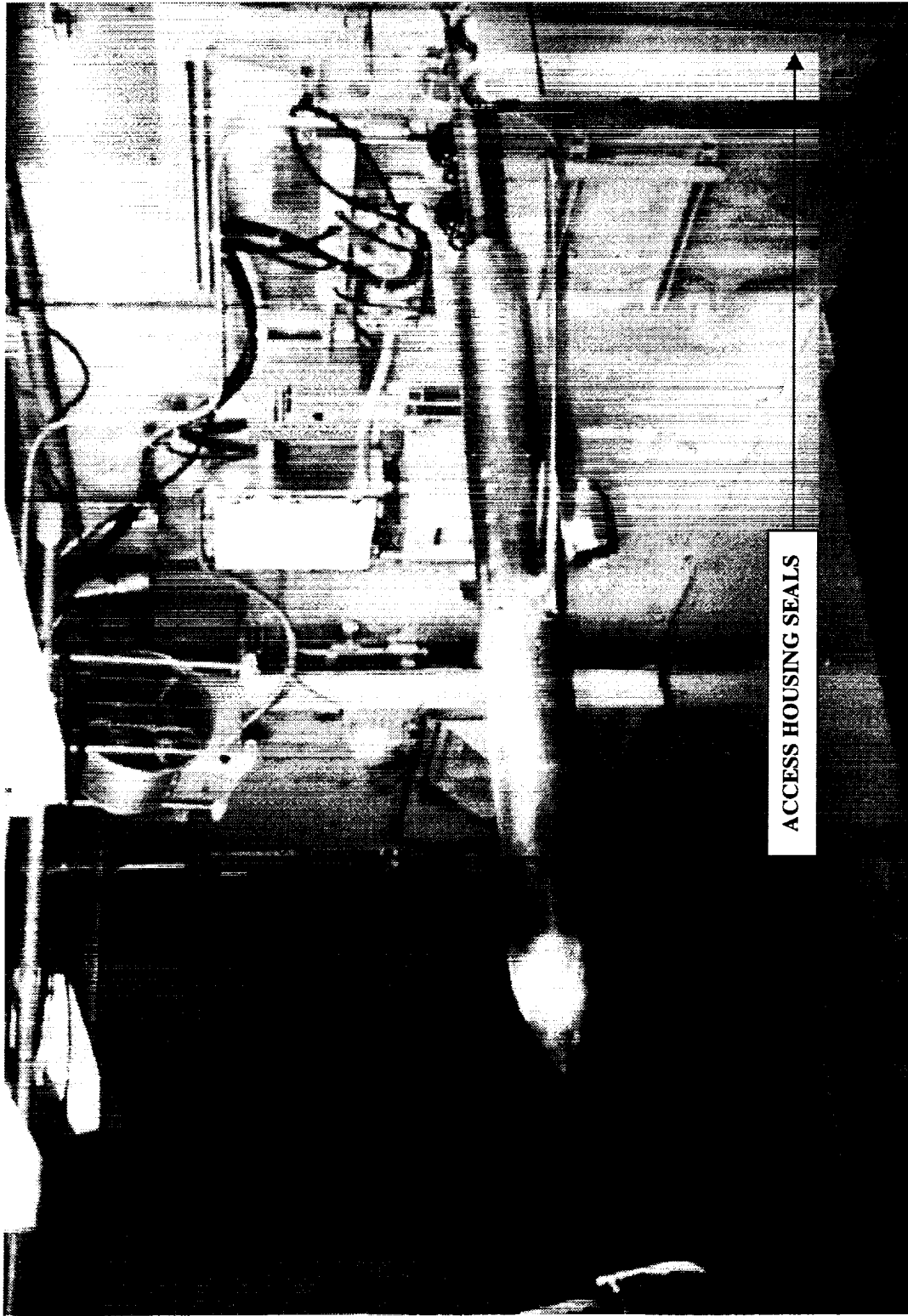

Figure 26. Stub sting being inserted into roll drive.



**Figure 27. Model access with access housings inserted.**

## MODEL SAFETY PROTECTION SYSTEMS

---

- Model Protection Microprocessor (Micro B)
  - Dynamic Pressure Limit Input
  - Arc Sector Range Limits Input
  - Violating any Limit will Automatically Fail-safe the Main Drive and Pitch System
- Balance Dynamic Display Unit (BDDU)
  - Monitors Force Balance Loads
  - Facilitates Control Room Monitoring
  - Provides Output for Additional Analysis
- Critical Point Analyzer (CPA)
  - Extends Force Balance Load Limitations
  - Sets Defined Boundaries for Unusual Set-ups
  - Provides Interlock Output
    - Reduces Dynamic Pressure (Mach Number)
    - Reduces Balance Load (Decrease Angle of Attack to a Predetermined "Pitch to Home" Position)
- Manual interlock input from test director and/or test engineer

Figure 28.

# FORCE BALANCE LOAD MONITORING

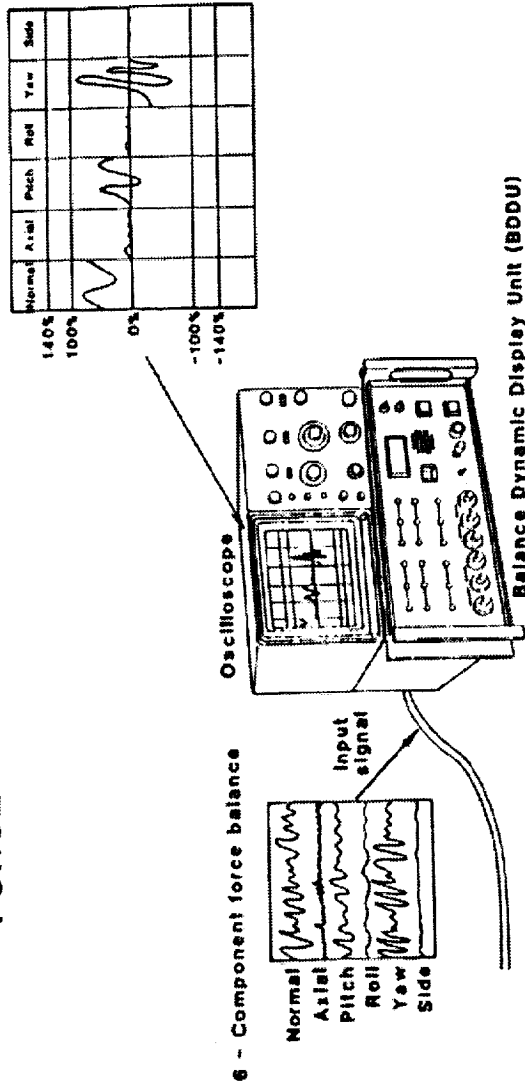

# CRITICAL POINT MONITORING

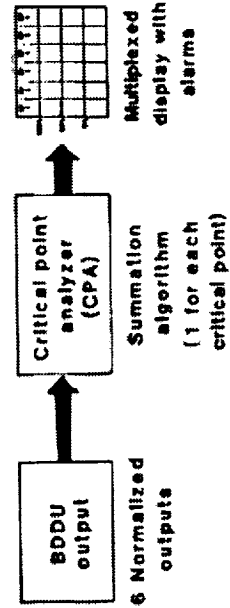

Figure 29.

# TYPICAL DISPLAYS

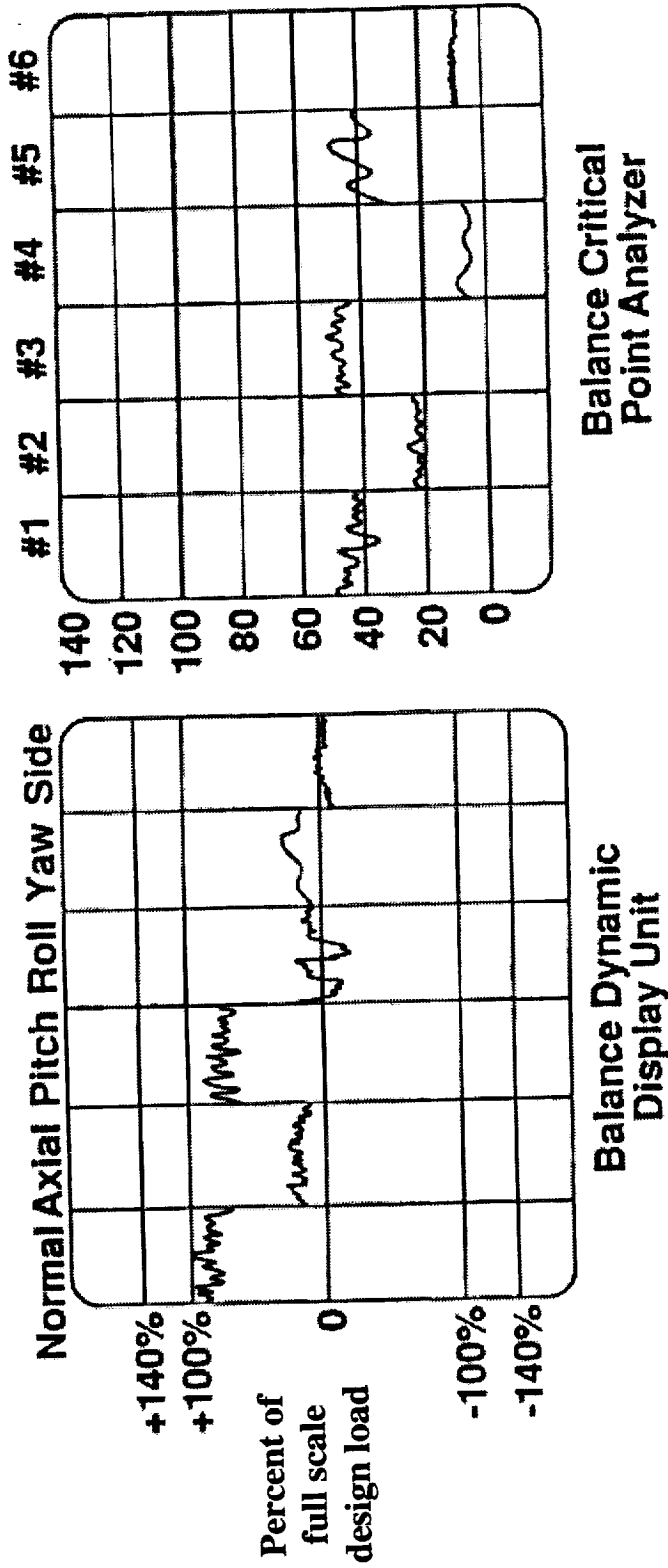

Figure 30.

# REPORT DOCUMENTATION PAGE

Form Approved  
OMB No. 0704-0188

Public reporting burden for this collection of information is estimated to average 1 hour per response, including the time for reviewing instructions, searching existing data sources, gathering and maintaining the data needed, and completing and reviewing the collection of information. Send comments regarding this burden estimate or any other aspect of this collection of information, including suggestions for reducing this burden, to Washington Headquarters Services, Directorate for Information Operations and Reports, 1215 Jefferson Davis Highway, Suite 1204, Arlington, VA 22202-4302, and to the Office of Management and Budget, Paperwork Reduction Project (0704-0188), Washington, DC 20503.

<b>1. AGENCY USE ONLY</b> (Leave blank)		<b>2. REPORT DATE</b> December 1998	<b>3. REPORT TYPE AND DATES COVERED</b> Contractor Report	
<b>4. TITLE AND SUBTITLE</b> A Microsoft Project-Based Planning, Tracking, and Management Tool for the National Transonic Facility's Model Changeover Process			<b>5. FUNDING NUMBERS</b> NAS1-96014 522-31-51-01	
<b>6. AUTHOR(S)</b> Daniel M. Vairo				
<b>7. PERFORMING ORGANIZATION NAME(S) AND ADDRESS(ES)</b> Lockheed Martin Engineering and Sciences Company Langley Program Office Mail Stop 371, NASA Langley Research Center Hampton, VA 23681-2199			<b>8. PERFORMING ORGANIZATION REPORT NUMBER</b>	
<b>9. SPONSORING/MONITORING AGENCY NAME(S) AND ADDRESS(ES)</b> National Aeronautics and Space Administration Langley Research Center Hampton, VA 23681-2199			<b>10. SPONSORING/MONITORING AGENCY REPORT NUMBER</b> NASA/CR-1998-208968	
<b>11. SUPPLEMENTARY NOTES</b> Langley Technical Monitor: Jerome T. Kegelman				
<b>12a. DISTRIBUTION/AVAILABILITY STATEMENT</b> Unclassified-Unlimited Subject Category 09 Availability: NASA CASI (301) 621-0390			<b>12b. DISTRIBUTION CODE</b>	
<b>13. ABSTRACT</b> (Maximum 200 words) The removal and installation of sting-mounted wind tunnel models in the National Transonic Facility (NTF) is a multi-task process having a large impact on the annual throughput of the facility. Approximately ten model removal and installation cycles occur annually at the NTF with each cycle requiring slightly over five days to complete. The various tasks of the model changeover process were modeled in Microsoft Project as a template to provide a planning, tracking, and management tool. The template can also be used as a tool to evaluate improvements to this process. This document describes the development of the template and provides step-by-step instructions on its use and as a planning and tracking tool. A secondary role of this document is to provide an overview of the model changeover process and briefly describe the tasks associated with it.				
<b>14. SUBJECT TERMS</b> National Transonic Facility, project planning, project management, Microsoft Project, wind tunnel model changes			<b>15. NUMBER OF PAGES</b> 58	
			<b>16. PRICE CODE</b> A04	
<b>17. SECURITY CLASSIFICATION OF REPORT</b> Unclassified	<b>18. SECURITY CLASSIFICATION OF THIS PAGE</b> Unclassified	<b>19. SECURITY CLASSIFICATION OF ABSTRACT</b> Unclassified	<b>20. LIMITATION OF ABSTRACT</b> UL	

NSN 7540-01-280-5500

Standard Form 298 (Rev. 2-89)  
Prescribed by ANSI Std. Z-39-18  
298-102