

115126

## Final Report for NASA's Planetary Astronomy Program - Grant NAGW-4016

The photodissociation of acetylene and acetone was investigated as a function of added quenching gas pressures using step-scan time-resolved FTIR emission spectroscopy. The apparatus used in these studies is shown schematically in Figure 1. Only a brief description of the apparatus is given here since it has been described in detail elsewhere.<sup>1</sup> Its main components consist of Bruker IFS88, step-scan FTIR spectrometer coupled to a flow cell equipped with Welsh collection optics. A Lambda Physik LPX 205i ArF excimer laser was used to photodissociate acetylene and acetone at 193.3 nm. It was pulsed at a repetition rate of 50 Hz and at a constant energy rate of 70 mJ pulse<sup>-1</sup>.

Vibrationally excited C<sub>2</sub>H radicals were produced from the photodissociation of acetylene in the unfocussed experiments. The infrared emission from these excited C<sub>2</sub>H radicals was investigated as a function of added argon pressure. A typical 4 cm<sup>-1</sup> time-resolved FTIR emission spectrum of the C<sub>2</sub>H radical at 3 μsec after the laser shot is shown on Figure 2. Argon quenching rate constants for all C<sub>2</sub>H emission bands are of the order of 10<sup>-13</sup> cm<sup>3</sup> molecule<sup>-1</sup>sec<sup>-1</sup>. Quenching of these radicals by acetylene is efficient, with a rate constant in the range of 10<sup>-11</sup> cm<sup>3</sup> molecule<sup>-1</sup>sec<sup>-1</sup>. The relative intensity of the different C<sub>2</sub>H emission bands did not change with the increasing argon or acetylene pressure. However, the overall IR emission intensity decreased, for example, by more than 50% when the argon partial pressure was raised from 0.2 to 2 Torr at fixed precursor pressure of 160mTorr. These observations provide evidence for the formation of a metastable C<sub>2</sub>H<sub>2</sub> species, which are collisionally quenched by argon or acetylene. A mechanism consistent with our observations and corroborated by computer simulations has been proposed.<sup>1</sup>

Experiments using a focussed ArF laser beam to photodissociate acetylene in the presence of argon yielded emission from 0-0 band of the  $B^1\Delta_g$  to  $A^1\Pi_u$  transition of  $C_2$ . Figure 3 shows the emission from this transition at  $3600\text{ cm}^{-1}$ . Modeling of this transition gives a reasonably good fit to the experimental data and it is shown on Figure 4.

In the experiment on photodissociation of acetone at 193 nm, two methyl radicals and a CO molecule are produced. Mohammad et al.,<sup>2</sup> showed evidence that  $CH_3$  radicals produced at this wavelength are highly vibrationally excited. These methyl radicals recombine to produce ethane with large amount of internal energy. Time-resolved FTIR emissions were collected and later modeled, in order to determine rate constants for the recombination of these  $CH_3$  radicals. A typical  $10\text{ cm}^{-1}$  time-resolved FTIR emission spectrum of the acetone photodissociation at different times following photodissociation are shown on Figure 5.

In the process of doing the experimental work we have encountered several problems. These problems were primarily do to failure of the spectrometer with occasional malfunctioning of the other components of apparatus. We will describe some of the difficulties encountered below:

1. ***Reproducibility of experimental data.*** We have not been able to consistently reproduce the experimental data, because the instrument does not maintain its optical alignment. To alleviate this problem we replaced the FTIR's internal HeNe laser used for the internal alignment. The instrument was manually realigned but it still often refuses to go into Align Mode or start a Step Scan experiment. We also discovered that the Acquisition Processor board (AQP) inside the PC was not communicating properly with the IFS88 electronics unit as well as the HeNe laser interference fringe test points LAS A

and LAS B looked wrong. We contacted Bruker's technical support and tried to resolve these problems. The first problem, communication between PC (AQP board) and IFS88, was resolved after removal of the relevant boards from their chassis, thoroughly cleaning all of the connectors, and reassembling the boards. The second problem, namely the wrong LAS A and LAS B interference fringes was due to failure of two op amps on the IFS88 Interferometer Board. The detailed explanation of this problem and its resolution is described in the attached preliminary report<sup>3</sup>. Both op amps were replaced and the spectrometer realigned to maximize the center burst (zero point difference).

2. ***Instrument software failure.*** Bruker's OPTics User Software (OPUS) consists of a set of software packages for data collection and processing of spectra from FT-IR, FT-NIR and FT-Raman spectrometers. It is designed to work well with the instrument in normal or rapid scan mode. The software component controlling the step-scan mode was added later and does not function properly at all times. We have tried all of the releases of the OPUS software and none of the versions of the program, which incorporate the step-scan mode in the proper way as of this time. Software bugs result in numerous freezes of the computer controlling the instrument at various times during the experiment.

3. ***Laser problems.*** Lambda Physik LPX205I excimer laser has not been stable producing reliable power output during the long experiments (i.e., one that were performed at high resolution with many coadditions to improve S/N ratio). The laser head was sent back to Lambda Physik and completely refurbished. Since that was done the laser has now been reliable.

**Future Plans:** As soon as we can confirm the results of our earlier studies, we will prepare papers on them. We are also planning to submit for publication the attached

preprint. Mr. Jacek Wróbel who has worked on this instrument is completing his Ph.D. and his results will be prepared for publication.

#### **References:**

1. M. Green, J.D. Wróbel, and W.M. Jackson, Time-Resolved FTIR emission studies of the photodissociation of C<sub>2</sub>H<sub>2</sub> at 193.3 nm. Presented at 22nd Annual Meeting of National Organization of Black Chemists and Chemical Engineers, Los Angeles, July 1996.
2. F. Mohammad, V.R. Morris, A. Clay Jones, and W.M. Jackson. Internal Excitation of CH<sub>3</sub> Produced in the Photolysis of Acetone at 193 nm and the Collisional Enhancement of the Infrared Emission Intensity in the  $\nu_3$  Spectral Range. *J. Phys. Chem.* **1993**, *97*, 6974-6978.
3. I.A. McLaren and J.D. Wróbel, UCD FTIR Knowledge Base Article #001 on Frequency Dependence of HeNe Laser Photodiode Amplifiers in the Bruker IFS88 FTIR Spectrometer.

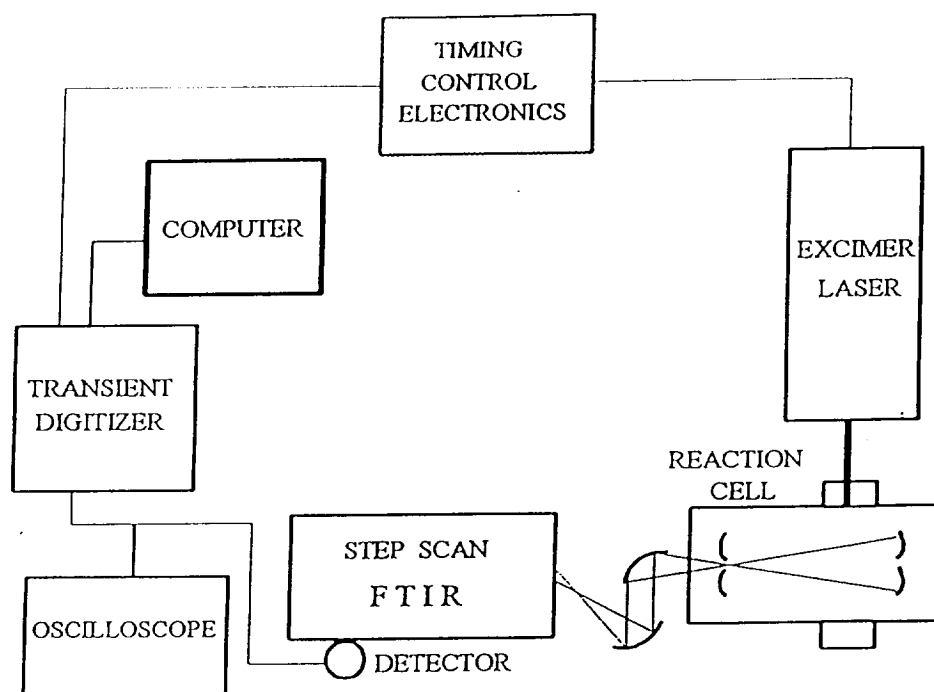

Figure 1. Apparatus used for the time-resolved FTIR emission studies.

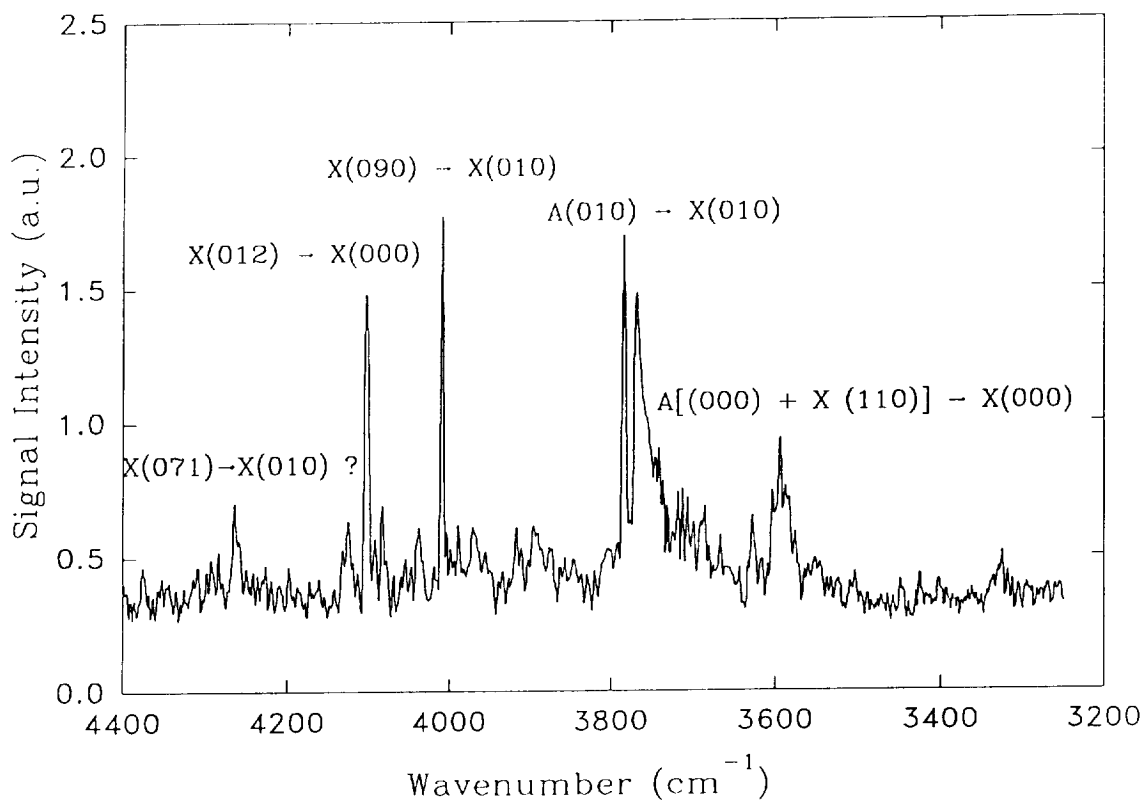

Figure 2. FTIR emission spectrum of C<sub>2</sub>H produced from the photodissociation of acetylene at 193 nm, taken 3 μs after the laser fired. C<sub>2</sub>H<sub>2</sub> pressure 160 mTorr and Ar pressure 572 mTorr.

**Figure 3. IR Emission Intensity as a Function of Wavelength at Different Times Following  
Photodissociation Event**

50 mT of C<sub>2</sub>H<sub>2</sub> and 1 Torr of Ar at 10cm<sup>-1</sup>

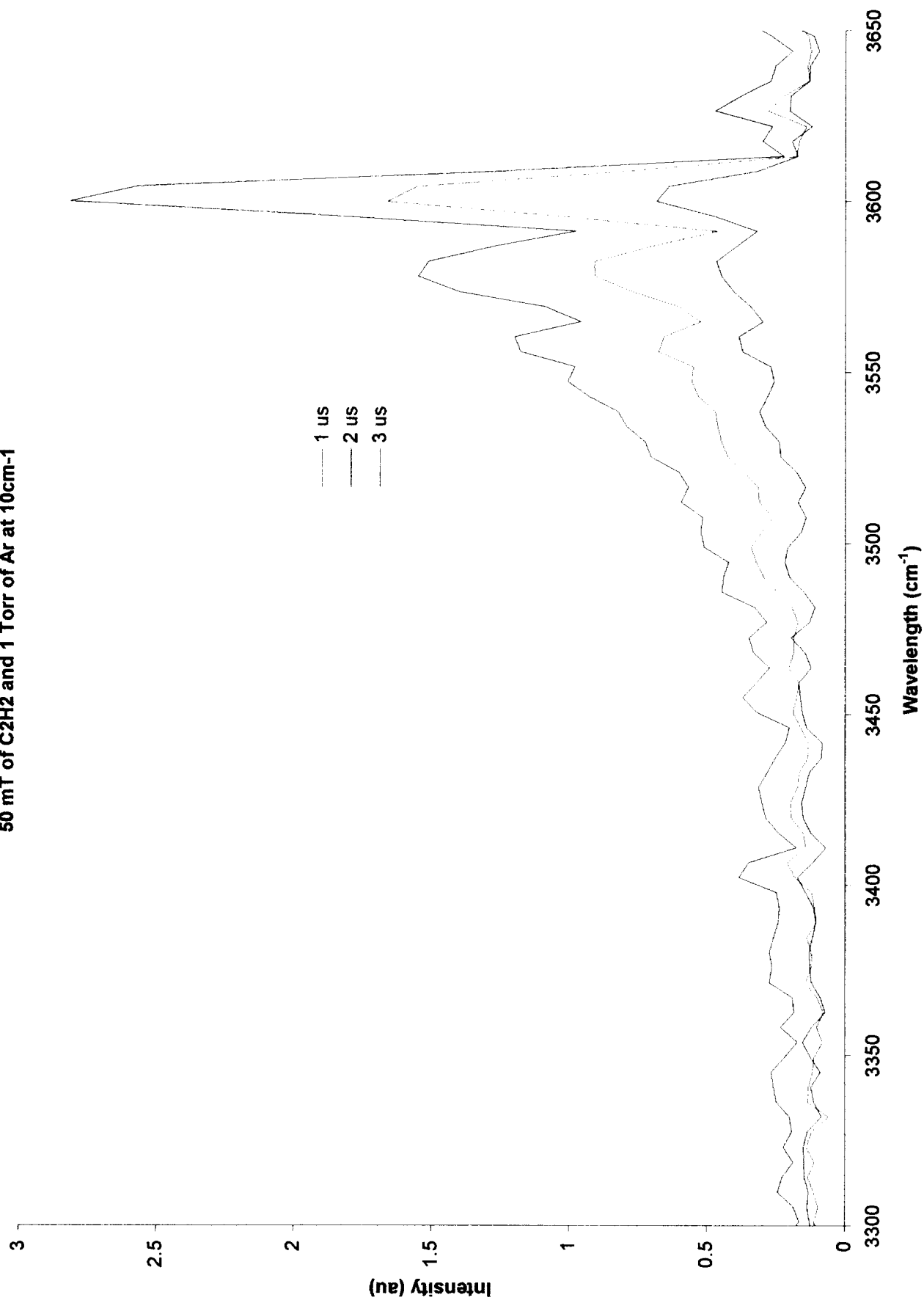
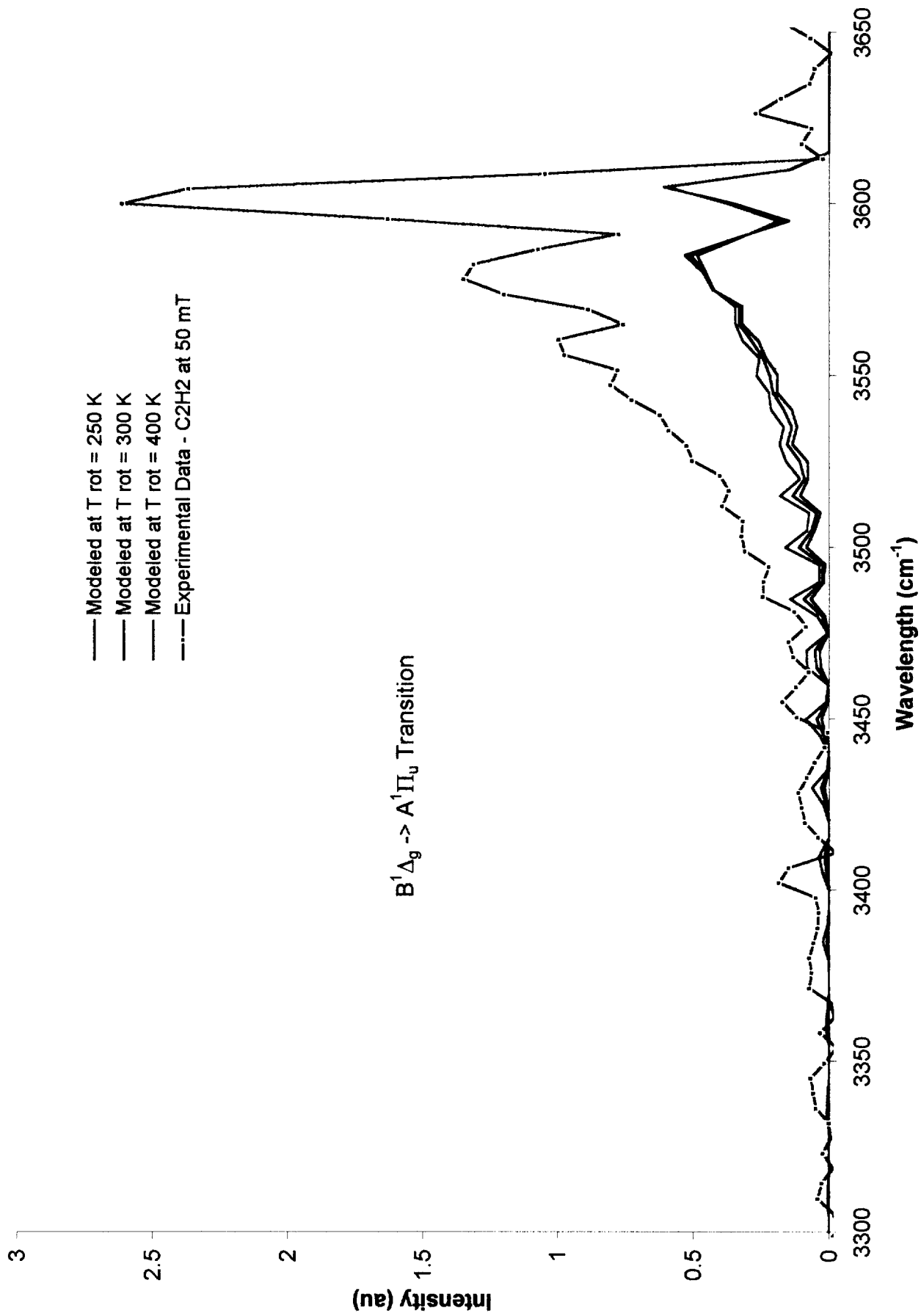

Figure 4. Modeled  $B^1\Delta_g \rightarrow A^1\Pi_u$  Transition

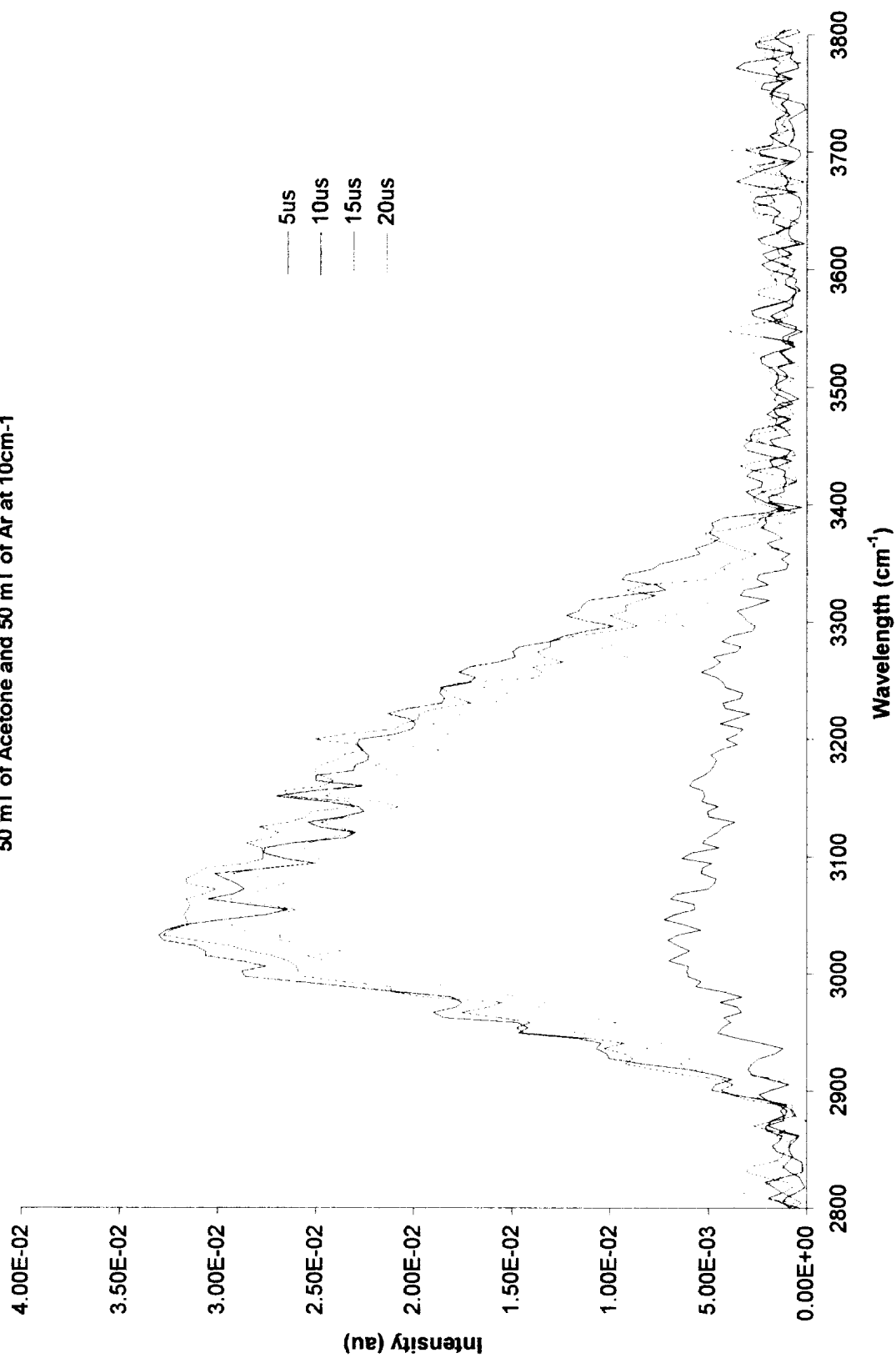



**Figure 5. IR Emission Intensity as a Function of Wavelength at Different Times Following**

**Photodissociation Event**

50 mT of Acetone and 50 mT of Ar at 10cm<sup>-1</sup>



## Frequency Dependence of HeNe Laser Photodiode Amplifiers in the Bruker IFS88 FTIR Spectrometer

### Description of Problem:

OPUS would not auto-align or go into Step-Scan Mode. With the scanner on, the "traffic light" LEDs on the IFS88's CDP (aka "Stop-and-Go") board were flashing red and yellow, with a very small amount of green. When operating correctly, the LEDs should flash green and yellow, with no red. The problem persisted despite repeated attempts (over the period of a week) to align the interferometer.

### Measurements:

Although the maximum signal level at test points "LASA" and "LASB" on the Interferometer Board were appropriate (4 to 5V peak-to-peak with a DC offset of ~1.5V in each case), and the scanner would start scanning when turned on, it was noted that the LASA waveform looked as shown in Fig. 1 (note that this is not a stored scope trace, but an "artist's representation" -- the fringes were in fact spaced much more closely than shown).

For LASA, the sine wave amplitude varied from 200mV p-p to about 4V p-p over the sweep period. The LASB waveform was similar, but without the same degree of amplitude modulation (approx 1V p-p at minimum to 5V p-p at maximum). Steve Burke of Bruker confirmed that the waveform shape (as described via telephone) was in no way normal -- that a difference in sine wave amplitude of ~10% could be expected between the forward and backward portions of the mirror sweep due to different sweep velocities.

Moving the mirror slowly by hand (with the scanner turned off) gave a p-p sinewave amplitude of 4V (LASA) and 5V (LASB), suggesting that the problem was not related to the optical alignment. Moving the scanner quickly by hand gave a decreased amplitude. Ideally, scanner speed should affect only the fringe spacing in time, and not the amplitude. The signals were measured at the outputs of the first stage of the 2-stage amplifiers for each of LASA and LASB, and found to have the correct shape, showing the problem to lie in the second stage amplifier circuits. Inspection of the board layout showed a designed second-stage RC feedback rolloff of 80kHz (200k $\Omega$  / 10pF) for LASA, and 160kHz (100k $\Omega$  / 10pF) for LASB.

The frequency of the interference fringe sinewave is equal to the HeNe laser frequency (in wavenumbers) multiplied by the scanner speed (in cm/sec). Thus at 5cm/sec, the frequency at LASA and LASB would be about 80kHz (= 15798 cm<sup>-1</sup> x 5 cm/s), which is equal to the designed turnover frequency ( $f_T$ ) for the LAS A 2nd stage amplifier circuit. It was clear that in this case, however, the amplifier  $f_T$  was considerably lower even than the designed value.

### Solution:

The operational amplifiers (Burr-Brown type OPA37) in the LASA and LASB second stages were replaced by the only pin-compatible op amps on hand at the time (TL071). Although these low-cost replacements are not particularly low-noise or high-frequency, the improvement was immediate. Swapping the OPA 37s around, it was found that the original LASA stage 2 OPA37 was by far the worst in terms of frequency performance, with an  $f_T$  estimated at 10kHz, followed by the LASB 2nd stage OPA37,

Fig. 1 UC Davis FTIR (Bruker IFS88) HeNe fringes at Laser A test point (one mirror sweep, 11/7/97, artist's representation -- fringe spacing not to scale)

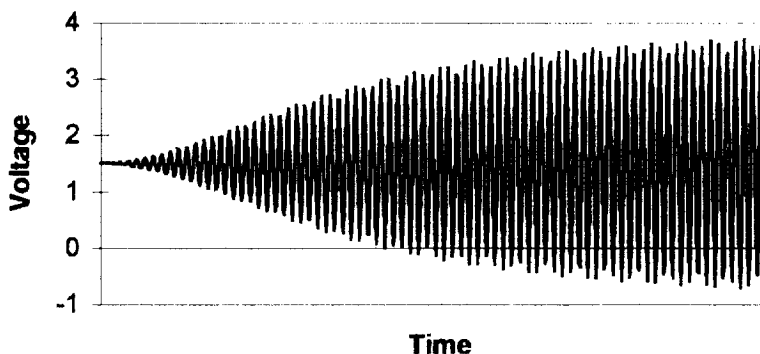

with the two 1st stage OPA37s showing acceptable performance (the 1st stage amplifier circuits had not shown a marked frequency dependence). What is unclear is how the OPA37s reached this situation --- degradation in frequency response is a highly unusual failure mode for op amps, and they cannot have always been bad or the mirror would never have scanned.

Since it was deemed desirable that the LASA and LASB amplifiers should have as wide a bandwidth as possible, the 10pF feedback capacitors in the two 2nd stages were removed from the circuit. The 1st stage was left alone, as frequency compensation was clearly not such a problem there, and the added stability is perhaps more of a factor than in the second stage.

After these changes were made and the IFS88 repowered, the scanner immediately started up, the LASA and LASB signals appeared normal, and the CDP board LEDs flashed green and yellow, with no sign of red. It was possible to align the spectrometer for maximum LASA and LASB signals in a matter of seconds. In addition, the signal from the IR detector was viewed directly on an oscilloscope while OPUS was operating in Align Mode, and the resulting interferogram centerburst maximized.

#### **Future Work:**

In the near future, the TL071 op amps will be replaced by lower noise versions, with wider bandwidth if need be. Cost is not a consideration: the TL071's are less than \$1 and the OPA37's less than \$2.

It has been under consideration for a while in this lab that the LASA and LASB test point signals should be buffered and brought outside the spectrometer housing to allow them to be monitored on a daily basis. It may even be advantageous to digitize the signals and store them with the Time-Resolved Inteferogram file, since they may provide a "figure of merit" of operation of the interferometer. It is certainly the case that if the LASA and LASB signals appear unusual, the spectrometer will not step accurately, which transforms to noise in the resulting spectrum. In extreme cases, the spectrometer will not align or scan at all. Usually, incorrect LASA or LASB signals are due to misalignment of the interferometer; however, in the case described here the fault is in the electronic circuitry.

It may be advantageous to bring the LASA and LASB photodiode signals directly out of the optical bench to a custom amplifier / digitizer unit, with LASA and LASB BNC connectors and potentiometers controlling the gain and offset of the LASA and LASB signals, and the digitized LASA and LASB signals sent to the PC controlling the experiment. (It should be noted that later versions of the Inteferometer Board apparently have gain and offset potentiometers designed in: it is possible that the amplifier frequency response problem noted here is only an issue with the older boards, such as that on the UCD instrument).