

NASA/CP—1999-209199



Proceedings of the Seventh International Space University Alumni Conference

Sheila Bailey, editor
Glenn Research Center, Cleveland, Ohio

Proceedings of a conference
held at Cleveland State University, Cleveland, Ohio
and sponsored by NASA Glenn Research Center
July 23–26, 1998

National Aeronautics and
Space Administration

Glenn Research Center

July 1998

Acknowledgments

I would like to thank Steven Berry, Lance Bush, Doug Messier, and Steven Cheung for their valuable suggestions and databank on the previous Alumni Conference in Houston. I would also like to thank Henry and Lin Chambers, Eri and Emeline Dahlstrom, and Jim Brice for their substantial physical and organizational support. I am also greatly appreciative of the efforts of Bryan Palaszewski, Pat Webb, and Frances Pipak who gracefully accepted the burden of my absence the month before the conference and made things happen. I would also like to thank NASA Lewis Research Center (now Glenn Research Center) and in particular Martin Kress, Deputy Center Director, for the institutional support necessary for this publication.

Available from

NASA Center for Aerospace Information
7121 Standard Drive
Hanover, MD 21076
Price Code: A06

National Technical Information Service
5285 Port Royal Road
Springfield, VA 22100
Price Code: A06

PREFACE

The Seventh Alumni Conference of the International Space University, coordinated by the ISU U.S. Alumni Organization (IUSAO), was held at Cleveland State University in Cleveland, Ohio on Friday, July 24, 1998.

These proceedings are a record of the presentations. I would like to thank Steven Berry, Lance Bush, Doug Messier, and Steven Cheung for their valuable suggestions and databank on the previous Alumni Conference in Houston. I would also like to thank Henry and Lin Chambers, Eri and Emeline Dahlstrom, and Jim Brice for their substantial physical and organizational support. I am also greatly appreciative of the efforts of Bryan Palaszewski, Pat Webb, and Frances Pipak who gracefully accepted the burden of my absence the month before the conference and made things happen. I would also like to thank NASA Lewis Research Center (now Glenn Research Center) and in particular Martin Kress, Deputy Center Director, for the institutional support necessary for this publication.

Sheila Bailey



TABLE OF CONTENTS

REMOTE SENSING EDUCATION AND DEVELOPING COUNTRIES: MULTILATERAL EFFORTS THROUGH THE COMMITTEE ON EARTH OBSERVATION SATELLITES (CEOS) Leslie Bermann Charles, NASA Headquarters.....	1
NASA'S CURRENT EARTH SCIENCE PROGRAM Leslie Bermann Charles, NASA Headquarters.....	9
TOWARD THE DEVELOPMENT OF AN INTEGRATED GLOBAL OBSERVING STRATEGY Leslie Bermann Charles, NASA Headquarters.....	15
LUNARSAT—EUROPES LUNAR INITIATIVE Peter Eckardt and Gernot E. Groemer, ¹ LunarSat Project Team.....	19
LUNARSAT SEARCHING FOR THE SOUTH POLAR COLD TRAPS Gernot E. Groemer, ¹ LunARSat Project Team.....	25
ASTEROID HAZARDS—AN ASSESSMENT OF CURRENT SURVEY AND ALERT STRATEGIES Gernot E. Groemer, Institute of Astronomy at the University of Innsbrook.....	33
ESA EXOBIOLOGY ACTIVITIES Gerhard Kminek, ESA/ESTEC.....	41
A SPACE TESTBED FOR PHOTOVOLTAICS Geoffrey A. Landis, Ohio Aerospace Institute, and Sheila G. Bailey, NASA Glenn.....	49
A TELEDESIC SPACE INFRASTRUCTURE OVERVIEW Mark G. Matossian, Teledesic Corporation.....	53
CONCURRENT DESIGN USED IN THE DESIGN OF SPACE INSTRUMENTS Knut I. Oxnevad, Jet Propulsion Laboratory, California Institute of Technology.....	59
NASA ADVANCED FUELS PROGRAM Bryan Palaszewski, NASA Glenn.....	69
MISSION PREPARATION AND TRAINING EQUIPMENT (MPTE) FOR THE EUROPEAN ROBOTIC ARM (ERA) Marcel Schoonmade, National Aerospace Laboratory NLR.....	77
EXPANDING GLOBAL ACCESS TO CIVILIAN AND COMMERCIAL REMOTE SENSING SYSTEMS AND DATA: IMPLICATIONS AND POLICY ISSUES G.J. Tahu, Stafford Group, J.C. Baker, Space Policy Institute, George Washington University, and K.M. O'Connell, RAND Corporation.....	89

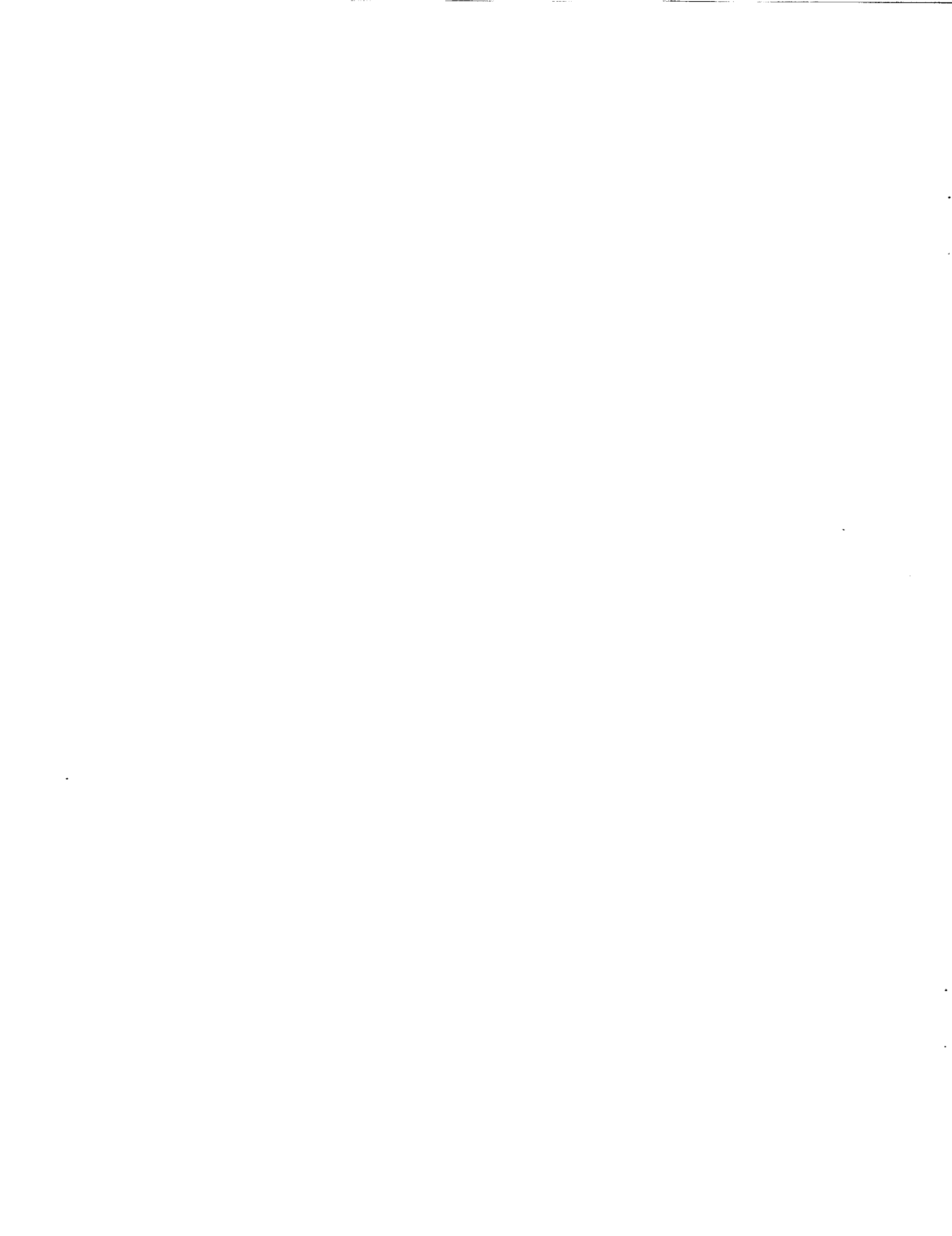

REMOTE SENSING EDUCATION AND DEVELOPING COUNTRIES: MULTILATERAL
EFFORTS THROUGH THE COMMITTEE ON EARTH
OBSERVATION SATELLITES (CEOS)

Leslie Bermann Charles
NASA Headquarters
Washington, DC

ABSTRACT

The Committee on Earth Observation Satellites (CEOS) is an international organization which coordinates space-based Earth observations world wide. Created in 1984, CEOS now comprises 38 national space agencies, regional organizations and international space-related and research groups. The aim of CEOS is to achieve international coordination in the planning of satellite missions for Earth observation and to maximize the utilization of data from these missions world-wide.

With regard to developing countries, the fundamental aim of CEOS is to encourage the creation and maintenance of indigenous capability that is integrated into the local decision-making process, thereby enabling developing countries to obtain the maximum benefit from Earth observation. Obtaining adequate access to remote sensing information is difficult for developing countries and students and teachers alike. High unit data prices, the specialized nature of the technology, difficulty in locating specific data, complexities of copyright provisions, emphasis on "leading edge" technology and research, and the lack of training materials relating to readily understood application are frequently noted obstacles.

CEOS has developed an education CD-ROM which is aimed at increasing the integration of space-based data into school curricula; meeting the heretofore unsatisfied needs of developing countries for information about Earth observation application, data sources and future plans; and raising awareness around the world of the value of Earth observation data from space. The CD-ROM is designed to be used with an Internet web browser, increasing the information available to the use, but it can also be used on a stand-alone machine. It contains suggested lesson plans and additional resources for educators and users in developing countries.

INTRODUCTION

CEOS Overview

CEOS is now recognized as the main international forum for the coordination of Earth observation satellite programs and for interaction of the space agencies with users worldwide. CEOS has three primary objectives:

- To optimize the benefits of spaceborne Earth observations through cooperation of its Members in mission planning and in the development of compatible data products, formats, services, applications, and policies;
- To aid both its Members and the international user community by, inter alia, serving as the focal point for international coordination of space-related Earth observation activities, including those related to global change;
- To exchange policy and technical information to encourage complementarity and compatibility among spaceborne Earth observation systems currently in service or development, and the data received from them; issues of common interest across the spectrum of Earth observation satellite missions will be addressed.

Individual participating agencies of CEOS use their best efforts to implement CEOS recommendations in their respective Earth observation programs.

Participating Agencies

Since its inception, CEOS membership has grown to encompass all the world's civil agencies responsible for Earth observation satellite programs, along with agencies that receive and process data acquired remotely from space. Several international user organizations, such as the World Climate Research Program and the United Nations Environment Program, have Affiliate status. Governmental organizations that are international or national in nature and have significant ground segment activity can apply to participate as Observers.

According to the CEOS Terms of Reference, Members are national or international government organizations responsible for developing and/or operating civil spaceborne Earth observation programs:

Australia	Commonwealth Scientific and Industrial Research Organization (CSIRO)
Brazil	Instituto Nacional de Pesquisas Espaciais (INPE)
Canada	Canadian Space Agency (CSA)
China	Chinese Academy of Space Technology (CAST) National Remote Sensing Center of China (NRSCC)
Europe	European Commission (EC) European Organization for the Exploitation of Meteorological Satellites (EUMETSAT) European Space Agency (ESA)
France	Centre National d'Etudes Spatiales (CNES)
Germany	Deutsches Zentrum für Luft- und Raumfahrt (DLR)
India	Indian Space Research Organization (ISRO)
Italy	Agenzia Spaziale Italiano (ASI)
Japan	Science and Technology Agency (STA) National Space Development Agency of Japan (NASDA)
Russia	Russian Federal Service for Hydrometeorology and Environmental Monitoring (ROSHYDROMET) Russian Space Agency (RSA)
Sweden	Swedish National Space Board (SNSB)
Ukraine	National Space Agency of Ukraine (NSAU)
United Kingdom	British National Space Centre (BNSC)
United States	National Aeronautics and Space Administration (NASA) National Oceanic and Atmospheric Administration (NOAA)

Observers are national or international government organizations with either a significant ground-segment activity or a civil space segment in the early phase of development:

Belgium	Federal Office for Scientific, Technical and Cultural Affairs (OSTC)
Canada	Canada Centre for Remote Sensing (CCRS)
New Zealand	Crown Research Institute (CRI)
Norway	Norwegian Space Centre (NSC)

Affiliates are other satellite coordination groups or international scientific and governmental organizations that complement CEOS activities:

Food and Agriculture Organization (FAO)
Global Climate Observing System (GCOS)
Global Ocean Observing System (GOOS)
Global Terrestrial Observing System (GTOS)
International Council of Scientific Unions (ICSU)
International Geosphere-Biosphere Programme (IGBP)
International Oceanographic Commission (IOC)

International Society of Photogrammetry and Remote Sensing (ISPRS)
United National Economic and Social Commission for Asia and the Pacific (ESCAP)
United Nations Environment Programme (UNEP)
United Nations Office of Outer Space Affairs (UNOOSA)
World Climate Research Programme (WCRP)
World Meteorological Organisation (WMO)

A standing Secretariat is maintained by ESA, NASA/NOAA, and STA/NASDA, and is chaired by the host organization in support of the CEOS Plenary.

Structure

The work of CEOS encompasses all the activities required for proper international coordination of Earth observation programs and maximum utilization of their data. It ranges from the development of detailed technical standards for data product exchange to the establishment of high level international principles on common data policies for different application areas, such as global climate change and environmental monitoring.

At the highest level within CEOS, the Plenary session meets once per year and brings together all Member, Affiliate and Observer agencies. The Plenary provides with a valuable forum to exchange information on relevant national/regional plans and activities, to discuss the impact of relevant developments worldwide, and to review progress on the various projects and activities being undertaken within the CEOS working groups and task forces.

There are currently two standing working groups:

1. The Working Group on Information Systems and Services (WGISS), with the specific goals:
 - to enable Earth observation data and information services to be more accessible and useable to data providers and data users world-wide through international coordination;
 - to enhance the complementarity, interoperability and standardization of Earth observation data and information management and services;
 - to foster easier exchange of Earth observation data and information through networks and other means, to meet the requirements of users and data providers.
2. The Working Group on Calibration and Validation (WGCV) provides a focus for coordination and cooperation in activities related to calibration and validation of Earth observations and addresses:
 - sensor-specific calibration and validation – to document and establish forums for the assessment and recommendation of current techniques and standards for pre- and post-launch characterization and calibration;
 - geophysical validation - to document and establish forums for the assessment and recommendations of techniques for validation of geophysical parameters derived from Earth observation satellite systems.

CEOS places great emphasis upon the communication between the providers of satellite Earth observation data (the space agencies) and users of the data who are represented in CEOS by the Affiliate agencies and which include agencies interested in global environmental research and operational monitoring.

On-line Services

CEOS agencies have sponsored the development of a number of on-line network data and information services to promote awareness and education concerning satellite Earth observation, to facilitate access to information about the data available, and to maximize utilization of that data worldwide.

The heart of the International Directory Network (IDN) consists of 3 coordinating nodes (maintained by NASA, NASDA, and ESA) which provide duplicate databases of directory information on-line for open access. Each

coordinating node has a number of regional cooperating nodes associated with it which provide a path for local users to access or contribute to the IDN. There are now a large number of such cooperating nodes throughout each region.

The CEOS Infosys is an on-line information service, available via the Internet's World Wide Web, which provides comprehensive and up-to-date information on CEOS activities and also provides an initial gateway to the many on-line services offered worldwide by CEOS agencies. The Infosys is maintained on-line by ESA. The URL for Infosys is <http://ceos.esrin.esa.it/infosys>.

Recognizing the need to provide users with access to Earth observation data which is as simple and as comprehensive as possible, CEOS working groups have undertaken a number of experiments on interoperability of on-line user services, such as catalogues and imagery browse systems, with the vision of realizing a system which would enable simple access to data resources held anywhere in the world. Prototype services are already in place.

Data Exchange and Utilization

With a view to promoting maximum utilization of Earth observation data collected worldwide, CEOS agencies have developed principles for the exchange of data in support of the key areas of global change research and operational environment use for public benefit. The mechanisms behind these principles are currently being tested in the context of the International Geosphere-Biosphere Program (IGBP) through a pilot project to exchange high-resolution image data between agencies.

Many other data exchange and utilization initiatives are underway in CEOS, including the standardization of data product calibration and validation procedures; the development of glossaries of technical terms; the development of data format standards, and the improvement of network connectivity.

DEVELOPING COUNTRIES AND REMOTE SENSING

Background

The potential of satellites for making observations which would be helpful to developing countries was recognized from the early days of space exploration. International forums like the United Nations (UN) stimulated discussion of the specific needs of developing countries in relation to space technologies and the concept of equity in relation to access to data acquired by space-borne, Earth observing instruments. In addition, the UN established a standing body, the Committee on the Peaceful Uses of Outer Space (COPUOS), with participation open to all UN members, to enable in-depth examination on these matters. The United Nations Office of Outer Space Affairs (UNOOSA) provides the secretariat for COPUOS, as well as services and facilities to the UN in respect of training and information about peaceful space application. UNOOSA participates in CEOS as an Affiliate.

Consideration of these important issues resulted in the systemization of important principles and Treaties which have greatly contributed to the peaceful development and use of space and to addressing of the needs of developing nations in particular. For example, the 1966 UN Treaty on Outer Space confirmed the notion that the use by humans of space should be in the interests of all humanity and it encouraged international cooperation in space missions. Of particular note are the 1986 UN Principles on Remote Sensing. These principles were designed to explicitly address concerns of developing countries relative to data access, technology transfer, and the encouragement of international cooperation. In 1989, the UN declared the 1990s to be the International Decade for Natural Disaster Reduction. Subsequently, numerous regional and international activities have been directed at improving the operation of natural hazard warning and amelioration programs. Natural disaster warning and mitigation are important, timely issues to most developing nations. Also worthy of note is "Agenda 21: Program of Action for Sustainable Development" adopted at the UN Conference on Environment and Development (UNCED) at Rio de Janeiro in June 1992. UNCED recognized the importance of new technologies such as remote sensing and geographic information systems, for systematically obtaining objective data on the state of the environment.

UNCED concluded that data-collection activities such as satellite-based remote sensing needed to be strengthened, and that these data should be analyzed, archived, and applied to pressing problems of sustainable development.

The number of satellite missions dedicated to Earth observation has increased significantly over the past decade and will further increase over the coming decade and beyond. Data from these missions offer the potential for contributing to the security of human existence on Earth in many ways. There are many examples of the value of space-based Earth observation data to development issues of particular interest to developing countries in the areas of food production, resource management, environment characterization and disaster warning and mitigation. CEOS is committed to assist in raising awareness of the value of remote sensing data and transferring knowledge about applications and benefits to developing countries.

CEOS Developing Country Initiatives

Agencies participating in CEOS are urged to use their influence, both within the framework of CEOS and in their own individual activities, to ensure that efforts are maintained in support of developing countries and are increased wherever possible. In addition, the CEOS Working Groups are advised to pay special attention to developing country initiatives, and coordination of these initiatives among the Affiliates and with aid-to-development organization is encouraged.

CEOS developing countries activities have expanded greatly since 1994. The CEOS Strategy Toward Developing Countries was adopted at the Eighth Plenary in September 1994, and a statement on developing countries in the Future CEOS Strategy was refined at the Ninth Plenary in 1995. In 1997, CEOS launched its Information Locator Service (CILS) for developing countries. CILS is a prototype electronic information service designed primarily to meet the requirements of users of Earth observation and remote sensing data in developing countries. CILS provides network-based means for users in developing countries to access information about satellite Earth observation and enables them to enter, administer and share their data and information. CILS also contains information of special interest to developing countries and provide relevant points of contact. CILS can be accessed at any of the following URLs:

<http://cils.dlr.de>
<http://cils.ceo.org>
<http://cils.unep.org>
<http://cils.eoc.csiro.au>

CEOS issued its first Annual Report on developing countries initiatives at the Eleventh Plenary in 1997. The Report is one initiative to implement the CEOS strategy with respect to developing countries. Primarily a vehicle to exchange views and information among CEOS participating agencies, the Report is expected to promote discussion on the implementation of the CEOS strategy and its relevance to drive practical actions. It will also help in identifying opportunities for new CEOS initiatives with developing countries.

CEOS CD-ROM

CEOS has also created a CD-ROM for use by developing countries and educators. Launched in 1996 and re-released in 1997, this CD-ROM has three primary objectives:

- To help meet unsatisfied needs of developing countries for information about Earth observation applications, data sources, and future plans;
- To help teachers and students around the world in learning about the world through observations from space;
- To strengthen worldwide understanding of the social benefits of Earth observation by satellite and of the efforts of international organizations such CEOS which attempt to make these benefits both widespread and equitably shared.

The main sections of the CD-ROM contain instructional modules, case studies, data sets, and lesson plans.

The CD-ROM is essentially a hands-on primer for users in developing countries and teachers alike, providing history, information and tutorials about the physics of remote sensing, examples of applications of Earth observation data, and links via the World Wide Web to ongoing activities within CEOS participating agencies' programs and data archives.

Modules

Module 1 is an overview introduction to remote sensing and contains a summary of Earth observation trends and missions. Module 2 is a university-level review of the fundamental physics of remote sensing. Module 3 covers the radiative properties of the atmosphere. Module 4 is an introduction to remotely sensed data. This module is comprehensive and deals with principles which can be applied to any remote sensing image enhancement system. The module covers the theoretical basis of remote sensing, instrument operation, and the basic techniques of image processing. Module 5 explains the basic physical principles in remote sensing. It is very comparable to the second module but presented in a more synthesized fashion. The last module, 6, contains an introduction to space oceanography and related space altimetric observing systems.

Case Studies

The CD-ROM contains numerous case studies and examples of applications of Earth observation to various real-life situations and problems. Students and users of the disk may select a case study by location or topic (i.e., meteorology, oceanography and climate, geology, renewable resource and environment, disaster mitigation, non-renewable resources, planning and infrastructure).

Many of the case studies contained on the disk give examples of application of space-based Earth observation data. One relevant example is natural disaster prediction and mitigation. Developing countries are not alone in suffering the consequences of natural disasters. However, the poor communication, housing and transportation infrastructure often means that their populations suffer more severely. Space technologies, as some of the case studies show, can play a uniquely powerful part in avoiding serious loss of life in the face of natural disasters in developing regions.

Case studies on the disk explore how satellite observations can assist both developing and developed countries in managing natural resources so that they meet not only present needs, but those of following generations.

Data Sets

The disk contains data acquired from various international satellite instruments. For each instrument there is a pictorial representation of the data to demonstrate some of the image processing tasks that may be performed on these types of data.

The data used to create the images in the data sets are also available on the CD-ROM. Users who also have access to image processing software can process these data themselves. The data are available in a number of different formats which most commercially available image processing packages can handle.

Remote Sensing for Education

In many ways, teachers and students face similar problems to developing countries in obtaining adequate access to this type of information. High unit data prices, the specialized nature of the technology, difficulty in locating specific data, complexities of copyright provisions, emphasis on "leading edge" technology and research, and paucity of training material relating to readily understood applications are all features which numerous international meetings pursuant to developing country interests have noted as applying to remote sensing. These same issues are

also cited by educators in developed as well as in developing countries, as standing in the way of greater classroom use of the results of international efforts to explore space and the Earth's environments.

The CD-ROM contains suggested lesson plans and activities for use in the classroom. It is hoped that educators around the world will integrate space-based data into their lessons plans. CEOS welcomes comments and feedback on the CD-ROM from teachers who have used it in order to help improve its next version.

Building Awareness

World annual expenditure on civilian meteorological and remote sensing satellites was about \$US 2 billion in 1994, according to Euroconsult. Much of this is budgeted by governments through public interest programs--those which are intended to give basic services to meet current community needs in health and safety; which are designed to protect the rights of future generations for environmental security; and which help to strengthen research capacity which will help to further improve quality of life and prosperity.

Space agencies, individually as well as collectively through organizations such as CEOS, are deeply committed to public outreach and awareness building. The CD-ROM is one CEOS initiative in this regard.

CONCLUSION

CEOS coordinates internationally all civil spaceborne Earth observation missions. Participating agencies represent space programs and research organizations from around the world. While a primary goal of CEOS is to study our planet and how it is changing, CEOS is also committed to working with developing nations and to highlighting the value of space-based data about Earth to their particular issues and needs.

The potential for social and economic benefits offered by space-based Earth observation data arise from its unique capabilities. These include the ability to provide near real-time monitoring of extensive areas of the Earth's surface at relatively low cost, as well as the capability to focus on particular land and sea surface features of interest to provide detailed, localized information. In some applications, satellite data can offer an alternative source for data which could be acquired by terrestrial or airborne surveying, but in a more timely and less expensive manner. In others, the availability of satellite data can provide a unique solution, for example where other techniques would be impractical.

Today, some applications of remote sensing data are rather mature, eg., in obtaining food from the oceans and the land, in mineral and energy resource extraction, and in transportation management. Benefits from these programs manifest themselves on a number of scales. On a global scale, the satellite coverage enables many applications to be directly relevant to international issues such as sustainable development and future food security. On a national scale, Earth observation data provides information which enables better management and utilization of resources and assessment and control the environmental impact of such utilization. On the scale of a single agency or company, applications such as the routing of ships, the laying of pipes under the oceans, logging, etc. offer significant economic and social benefits. In all cases, remotely sensed data can assist developing countries in addressing economic development and related issues of importance to them.

The CD-ROM developed by CEOS is intended to be one of many initiatives to demonstrate the value of Earth observation data to developing countries and educators around the world. By increasing the awareness of Earth observation data and its applications, CEOS hopes to maximize the utilization of remote sensing data and its applications.

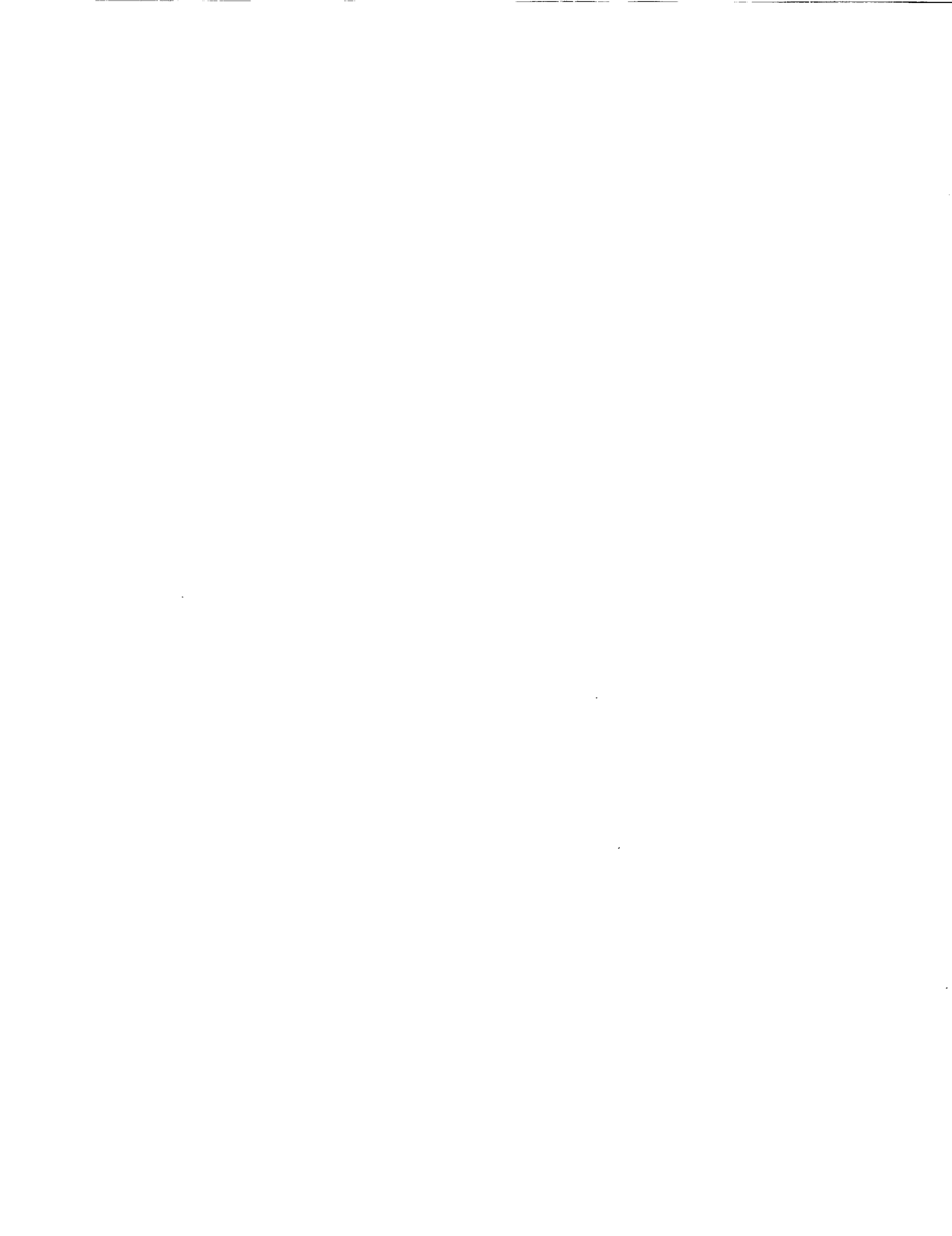

NASA'S CURRENT EARTH SCIENCE PROGRAM

Leslie Bermann Charles
NASA Headquarters
Washington, DC

ABSTRACT

NASA's Earth science program is a scientific endeavor whose goal is to provide long-term understanding of the Earth as an integrated system of land, water, air and life. A highly developed scientific knowledge of the Earth system is necessary to understand how the environment affects humanity, and how humanity may be affecting the environment. The remote sensing technologies used to gather the global environmental data used in such research also have numerous practical applications. Current applications of remote sensing data demonstrate their practical benefits in areas such as the monitoring of crop conditions and yields, natural disasters and forest fires; hazardous waste clean up; and tracking of vector-borne diseases. The long-term availability of environmental data is essential for the continuity of important research and applications efforts. NASA's Earth observation program has undergone many changes in the recent past.

NASA'S EARTH SCIENCE PROGRAM

Since its creation in 1958, the National Aeronautics and Space Administration of the United States (NASA) has been using the unique perspective from space to study the Earth. To build on and augment these long standing activities, NASA initiated a more comprehensive Earth observation program in 1991. Formerly referred to as the Office of Mission to Planet Earth, NASA's Earth Science Enterprise (ESE) seeks to understand the total Earth system and the effects of natural and human-induced changes on the global environment. Primarily a science program, ESE is pioneering the new interdisciplinary field of research called Earth System Science, born of the recognition that the Earth's land surface, oceans, atmosphere, ice sheets and biota are both dynamic and highly interactive. Earth System Science is one of the most complex endeavors of research in all of modern science. It is also an area of research with immense benefits, yielding new knowledge and tools for weather forecasting, agriculture, urban and land use planning, and other areas of economic and environmental importance. In concert with other agencies, international partners and the global research community, NASA is providing the scientific foundation needed for the complex policy choices that lie ahead on the road to sustainable development.

SATELLITE SYSTEMS

The Earth Science Enterprise is comprised of three main components: a flight program which obtains data from a series of Earth observing satellites, airborne and Space Shuttle missions along with calibrating ground-based data; an advanced data and information system; and, a scientific research and analysis program. ESE's progress toward its overall goal can be described in two phases. Phase I of the program is already underway and includes satellites dedicated to the study of specific processes in Earth system science. For example, the joint U.S.-Japanese Tropic Rainfall Measuring Mission (TRMM), launched in 1997, is the first space mission dedicated to observing and understanding tropical rainfall, which comprises more than two-thirds of all rainfall, and how it affects the global climate. By studying rainfall regionally and globally, and the difference in ocean- and land-based storms, TRMM is providing scientists the most

detailed information to date on the processes of these powerful storms, leading to new insights on how they affect global climate patterns. These data are being used by hurricane researchers in their forecast models.

Another example of the important science currently being conducted is the ongoing investigations of atmospheric ozone concentrations. Since the launch of the first Total Ozone Mapping Spectrometer (TOMS) instrument in 1978, NASA has been studying ozone levels. Ozone depletion is one of the most clearly documented cases of human activity inducing global change within the span of two generations. Stratospheric ozone is critical for the maintenance of life on Earth, as it blocks harmful solar radiation from reaching the surface. Data from TOMS and ground-based sensors indicate that, over the past 15 years, the amount of solar ultraviolet radiation reaching the earth's surface has increased and that during the same period the amount of total ozone in the atmosphere has decreased. This is significant because increased exposure to solar radiation has been linked to several forms of skin cancer. To ensure continuity of this important TOMS data set, NASA launched a TOMS instrument in July 1996 and plans to launch a joint TOMS mission with Russia in 2000. These instruments will provide coverage of the entire Earth well into the next century. Continuing and related ozone measurements will be made cooperatively with the Netherlands starting in 2002 as part of the Earth Observing System Chemistry mission.

Phase II begins next year with the launch of the first satellite in the Earth Observing System (EOS) series. EOS will be the first remote sensing satellite system to offer integrated measurements of Earth processes emphasizing calibration. Prior to the EOS era, global changes in the atmosphere, land surface, water and life were studied as isolated events. EOS, however, will examine these parameters as interconnected and interactive forces. Scientists will use these integrated EOS measurements to form models and to build a comprehensive understanding of the Earth as a whole. EOS AM-1 will begin the continuous, long-term, calibrated measurements of global processes to improve understanding of the Earth's surface, clouds, aerosols and radiation balance. Other EOS missions will follow in subsequent years and target other aspects of the Earth system.

EOS DATA SYSTEM AND DATA DISTRIBUTION

The availability of Earth science data to a wide community of users is critical to the success of NASA's Earth science program. Therefore, NASA is committed to facilitating broad access to the Earth science data it generates. The EOS Data and Information System (EOSDIS) is being developed to meet this commitment. An initial version, called Version 0, is in operation now. EOSDIS is an integrated system which provides quick and easy access to data and information for a broad range of users, including scientists, educators, governments, businesses and the general public. Scientists around the world will evaluate environmental data from EOS, and, as a consequence, develop and improve integrated global models of Earth system processes. And, NASA expects that a broader community of users will access the data using EOSDIS to study the societal and economic implications of near-term and long-term changes in the global environment.

EOSDIS processes, stores and distributes critical information to thousands of international scientists and other users. Products are available now from TOPEX/Poseidon, the Upper Atmosphere Research Satellite (UARS), and other operational and historical missions. EOSDIS will also command and control satellites and instruments and will generate products from orbital observations.

Consistent with U.S. law, data from EOSDIS are available to all users without restriction and at not more than the cost of dissemination, without regard to intended use. This means that users may be charged the costs of fulfilling an order, which may include machine use to execute searches, preparation of data for electronic or media delivery and to perform any unique data processing, packaging and media, and dissemination costs (e.g., postage). NASA believes its data policy is a critical element in making data easily available to a wide number and range of users, will encourage global climate change research and will help foster other applications of the data.

APPLICATIONS OF EARTH SCIENCE DATA

In addition to information on the global environment and how it is changing, remote sensing technology provides important information on issues that are important at a regional and local level. How the Earth works and how it is changing are concerns to groups other than scientists. Local and regional governments and the business community are also interested in these issues. The first and probably the most well known application of remote sensing data is in weather forecasting. In 1960, NASA launched the world's first meteorological satellite, providing improved and timely information on weather conditions.

Meteorological information from satellites has revolutionized weather prediction and is now commonplace in weather forecasts today. Remote sensing data on weather have become so integrated into everyday life that many people now expect to see images from weather satellites when they tune in to the news on television. In the coming years, observations from EOS and other satellites should significantly improve our ability to predict both near-term weather and longer-term climatic shifts.

Remote sensing technologies contribute to a wide range of practical environmental questions. Areas where satellite data are increasingly being used are: natural disaster prediction and monitoring; resource management; the identification and extraction of mineral and resource deposits; food security and increasing the availability of food and water; sustainable development and environmental security; civil engineering and urban planning; animal habitat monitoring; and forest inventory and protection. Several examples of applications that have benefited from NASA's remote sensing research are presented below.

Natural Disasters

An important example of a practical application of remotely-sensed data is in the prediction and monitoring of natural disasters. Natural disasters, such as floods, hurricanes and earthquakes, cost the U.S. alone tens of billions of dollars each year. Improved forecasting of severe storms has led to better preparation of the populace before such storms and a mitigation of resulting damage. For example, the U.S.-French ocean-observing TOPEX/Poseidon spacecraft has acquired data on sea surface and wave height which help explain the periodic alteration of the typical atmospheric jet stream pattern around the world called El Nino. The 1997-98 el Nino has been the strongest ever recorded and was responsible for record rainfall in California, heavy flooding in Peru, drought and wildfires in Indonesia, tornadoes in the southeast U.S. and loss of life and property damage worldwide. Eventually, due to the improved scientific understanding and improved forecasting capabilities made possible by such satellite data, El Nino oscillations will be included into long range weather prediction.

It is envisioned that in the future the insurance industry will use environmental information in much the same manner as they use life expectancies and actuarial tables today. Whether the benefits are measured in terms of lives saved or economic loss, the usefulness of space-based remote sensing in natural disasters is no longer in question

Lyme Disease Prevention

NASA's remote sensing technology is even being used by public health officials to reduce public exposure to Lyme disease, currently the most commonly reported vector-borne disease in the U.S. Lyme disease is transmitted by deer ticks to dogs and frequently to people. Although treatable, Lyme disease can lead to disabling health effects and even death if not treated early. Because symptoms of Lyme disease are non-specific, early diagnosis is often difficult. Therefore, the best prevention is an informed populace, avoidance of areas high in deer ticks, and pest control. By identifying areas of highest potential for this disease, cost effective steps can be taken in specific areas to reduce the risk through public notification and tick control measures.

Lyme disease risk depends on the presence of several elements of landscape in the same geographic location at the same time. The use of NASA remotely-sensed data plus geographic information system (GIS) technology allow an inexpensive and accurate means to identify quickly the areas where those elements that contribute to Lyme disease exist. Landsat vegetation cover analysis viewed against data on the percent of dogs that tested positive for Lyme disease within a municipality have validated this technique as an effective tool. Similar techniques have been used to monitor other vector-borne diseases and insect movements, such as desert locusts which can impact crops.

Vineyard Health

The California wine industry is using remote sensing data to mitigate crop losses due to root-lice (phylloxera) infestation. The \$9 billion per year industry estimates that total yearly losses due to phylloxera in the Napa Valley alone is approximately \$350 million. NASA has teamed with Robert Mondavi Winery, the University of California, and California State University to combine data taken from aircraft and satellites to create a computerized database. Digital sensors aboard aircraft are being used to detect and quantify vineyard decline associated with infestation, while data from the Landsat satellite are being used to monitor associated decreases in vineyard acreage across large regions. Combined in the database, these data will help identify fields at risk of future outbreak a year ahead of time. This advance warning will enable the wine industry to manage their vineyards in the most cost-effective manner possible and to generate more accurate financial forecasts. It is anticipated that this technology will be used in other wine-growing regions of the U.S. West Coast and in the broader agricultural community.

NEW APPROACH FOR POST 2002

NASA conducted its first Biennial Review of its Earth observation program last year. This review has proven to be one of the most significant vehicles for evolution of the Earth science program at NASA. Through careful consideration of scientific, technological and mission changes recommended by our scientific, international and business partners, ESE aims to capitalize on advances in science and technology and to identify opportunities for new and expanded collaborations with commercial, international and interagency partners. ESE intends to conduct these reviews every two years.

A major outcome of the Biennial Review was the development of a new paradigm for mission planning in the post-2002 era. The ESE has recently issued a Request for Information (RFI), kicking off implementation of this new paradigm. The RFI can be accessed at URL = <http://www.hq.nasa.gov/office/ese/nra/RFIdodge/index.html>

The goals of this effort are to develop further the scientific measurement strategy initiated in the first series of EOS satellites and to take advantage of today's advanced technologies and launch opportunities. Through this RFI, NASA is seeking to obtain ideas from the science and applications communities for post-2002 mission concepts and then use these ideas to develop a nominal mission profile which will best fit NASA's science and applications objectives, expected technological capabilities and programmatic constraints for the 2003-2010 time frame.

The RFI was posted on the world wide web in May 1998 with responses due by early June. A screening process and mission concept assessments are currently underway to classify responses received according to science or application merit, advances from existing and planned remote sensing measurements, and technical feasibility. A workshop will be held in August 1998, comprised of a panel of experts selected by NASA and one representative from each of the mission concepts developed through the screening and concept assessment phase. The outcomes of the workshop will refine the proposed the nominal flight program developed from the proposals and ideas for improvement of the review process. NASA intends to refresh periodically this nominal mission profile through similar consultations with the Earth system science and applications communities.

In developing its measurement strategy and embracing NASA's overall "faster, better, cheaper" philosophy, the ESE desires to reduce the risk to overall program objectives from any single mission failure by developing smaller, less expensive missions and implementing shorter development cycles from mission definition to launch. Shorter development times will allow more flexible responses to current and evolving scientific priorities and more effective uses of the latest technologies. In accordance with this philosophy, the implementation of each successive future mission in the ESE flight program will be based on a specific Announcement of Opportunity (AO) and competitive selection of instrument payloads and implementation options. It is important, under this new approach, that instrument technology developments be conducted largely before the relevant mission payload selection. A science and applications-based flight mission profile is indispensable to guide these pre-mission technology developments. NASA Research Announcements can be found at:

<http://www.hq.nasa.gov/office/ese/nra/index.html>

AN INTERNATIONAL EFFORT

NASA's Earth science program is part of an international effort to study our Earth and climate change. By its very nature, global environmental questions require the cooperation of all nations. No one country can accomplish the comprehensive research needed alone. And, it is vital that the scientific results be the work of the international research community so that they have credibility as the basis for policy decisions and actions around the world. Since the 1980s, NASA has been working closely with its partners around the world to coordinate satellite observation programs and to work together on a number of satellite missions, aircraft and balloon campaigns, and ground-based activities, as well as data exchanges and scientific research.

NASA's Earth science program has partners in over 45 countries. In the last 3-4 years alone, over 60 agreements have been made ranging from data exchange to cooperative space flight missions. Over roughly a ten-year span, NASA's international partners are investing roughly \$4.0 billion in bilateral activities with ESE and another \$4.7 billion in complementary missions for a total roughly equivalent to the U.S. investment.

In addition to these bilateral efforts, NASA is a member of the multinational Committee on Earth Observation Satellites (CEOS). Comprised of 38 national and international space and scientific organizations, CEOS serves as the focal point for international coordination of space-related Earth observation activities. Through a 'best efforts' approach, CEOS agencies exchange policy and technical information to encourage complementarity and compatibility in mission planning and in the development of compatible data products, formats, services, applications and policies.

NASA intends to continue these and other successful international collaborations. Currently operating missions and those under development will be continued. In addition, discussions with NASA's international partners on cooperation in the program in the post-2002 timeframe will begin this fall.



TOWARD THE DEVELOPMENT OF AN INTEGRATED GLOBAL OBSERVING STRATEGY

Leslie Bermann Charles
NASA Headquarters
Washington, DC

ABSTRACT

In the current environment of stagnant or shrinking budgets for space research and exploration, nations can no longer afford to develop costly systems in a vacuum. Greater coordination of existing and planned systems, both among space agencies and between the space agencies and user communities, will enable the maximization of global investments in all areas of space-related research. In this manner, a group of space agencies has embarked on an initiative to link their activities in Earth observation with complementary observation programs. The goal of this initiative is to develop a comprehensive strategy for enhanced levels of support to scientific, operational and research communities.

The space agencies, through the Committee on Earth Observation Satellites (CEOS), have embraced the concept of an Integrated Global Observing Strategy (IGOS), primarily in fulfillment of their own set of objectives and to derive greater benefit from both operating and planned Earth observing systems. Through working together, CEOS agencies are in a position to plan their Earth observation projects with the minimum of unnecessary overlap and to devise joint strategies for addressing serious gaps in their observation capabilities. Ultimately, an IGOS should be the joint product of all groups involved in the collection and analysis of both space-based and in-situ data. CEOS is actively seeking IGOS -related partnerships with the Global Climate, Global Ocean and Global Terrestrial Observing Systems, their intergovernmental Sponsors, the International Group of Funding Agencies for Global Change Research, and other scientific and user organizations including the International Geosphere-Biosphere Programme and the World Climate Research Programme.

CEOS

The Committee on Earth Observation Satellites (CEOS) is an international organization which coordinates space-based Earth observations world wide. Created in 1984, CEOS now comprises 38 national space agencies, regional organizations and international space-related and research groups. The aim of CEOS is to achieve international coordination in the planning of satellite missions for Earth observation and to maximize the utilization of data from these missions world-wide.

CEOS has embarked on an exciting initiative to link its activities involving coordination of the space component for Earth observation with complementary observation programs. The goal of this initiative is to develop a comprehensive strategy for enhanced levels of support to scientific, operational and research communities. CEOS has embraced the concept of an Integrated Global Observing Strategy (IGOS), primarily in fulfillment of its own set of objectives and to derive greater benefit from both operating and planned observing systems, in support of an increasing range of applications for understanding global processes. Individual agencies, too, are currently facing the most challenging budgetary environments that they have been exposed to for many years. Through working together, CEOS agencies are in a position to plan their Earth observation projects with the minimum of unnecessary overlap and to devise joint strategies for addressing serious gaps in their observation capabilities. A critical part of the CEOS approach is the conduct of a requirements analysis based upon specifications provided by user and applications communities. Through this process user requirements will help drive the planning process for

space missions. Additionally, plans for space-based observation requirements are being integrated with complementary observation strategies, including in-situ measurements.

In 1996, CEOS created the Strategic Implementation Team (SIT). Comprised of CEOS Principals with the authority to commit agency support to initiatives as they unfold, the SIT is CEOS' main forum for developing and discussing the concept of an IGOS and liaising with potential partners. The group was given the responsibility to define, characterize and develop a vision for an IGOS; define responsibilities of the space component of an IGOS; and address, with appropriate partners, the interface between the space component and the in-situ component.

CHARACTERISTICS OF AN IGOS

A key characteristic of an IGOS will be the achievement of outcomes that are beyond the present capabilities of existing observing systems. An IGOS will address the collection of both space-based and in-situ data. It will make possible the creation of improved higher level products by facilitating the integration of multiple data sets from different agencies, national and international organizations. An IGOS can provide an overarching strategy for observations to allow organizations involved in the collection of data to respond to user requirements and to assist user groups requiring information from the systems to specify their requirements in a synergistic, coherent way, thus maximizing the probability that the requirements will be met. In addition, an IGOS should reduce unnecessary duplication of observations and assist in the improved allocation of resources between different types of observation systems. Ultimately, it is hoped that an IGOS will assist in the improved allocation of resources between different types of observation systems and within agencies themselves. Continuity of key observations is another goal. An IGOS will also assist in the transitioning of systems from research to operational status through enhanced international cooperation.

PROTOTYPE PROJECTS

So far, the development of the concept of an IGOS and its benefits has been mainly focused on the integrated development and implementation for a set of six IGOS prototype projects: global ocean data assimilation, upper air measurement, long-term continuity of ozone measurements, ocean biology, global observations of forest cover, and disaster management support. The projects were chosen on the basis of their relevance to global change issues and global requirements and that they would demonstrate some achievable results in a realistic timeframe. Each project is led by a space agency together with a user organization in order to maximize user input in its definition. The projects are underway, each at varying stages of implementation and success. The SIT intends to use lessons learned from these projects and apply them globally to other areas which would be addressed by an IGOS. The lessons from these projects will be instrumental in developing the IGOS strategic plan.

IGOS PARTNERSHIP

From the beginning, an IGOS was envisioned to address the common interests of the major space-based and in-situ systems for global observations of the Earth. Thus, partnership between the data providers and user communities is essential for the success of IGOS. Together, partners will further advance the definition, development and implementation of an IGOS.

The formalization of the concept of partnership in IGOS came in June 1998. CEOS, the Sponsors of the three Global Observing Systems (Global Climate, Global Terrestrial and Global Ocean), the International Group of Funding Agencies for Global Change Research (IGFA), the International Geosphere-Biosphere Programme (IGBP) and the World Climate Research Programme (WCRP) met and agreed to a basic understanding of partnership in working toward an IGOS. The IGOS partners will codify their

understanding through an exchange of letters with an accompanying annex which will include corresponding overall principles, objectives and mechanisms. This initial exchange of letters is expected to occur prior to the Twelfth CEOS Plenary meeting in Bangalore, India, in November 1998.

NEXT STEPS

CEOS is preparing a preliminary draft of the space component of an IGOS strategic plan. The draft will be presented to the CEOS Plenary in November 1998. It is anticipated that in-situ and user components will be added to the strategy and that all pieces will make an integrated whole. Concurrently with the development of the space component of the strategy, CEOS will continue working with the Global Observing Systems and their Sponsors, IGFA and others. Additional partners in the IGOS development process will be actively sought. The IGOS partners have agreed to hold a special workshop on IGOS at the UNISPACE III Conference in Vienna in July 1999.



LUNARSAT—EUROPES LUNAR INITIATIVE

Peter Eckardt and Gernot E. Groemer¹
LunarSat Project Team

Abstract

LunarSat is a micro-spacecraft that will be sent into an orbit around the Moon to perform scientific investigations concerning the lunar environment and its characteristics. LunarSat is designed by young engineers, scientists, and students from around Europe, with support from numerous institutions and space industry. It shall be launched as an auxiliary payload on an Ariane 5 ASAP platform and will have a mass of 100 kg in GTO. LunarSat will orbit the Moon on a highly elliptical polar orbit with its perigee above the lunar south pole area. This orbital strategy yields the possibility to obtain images of the lunar south pole region with a resolution never achieved before.



1. Background

In July 1996, 52 students, young scientists and engineers from 15 different European countries gathered in Alpbach, Austria, for the ESA Summer School "Mission to the Moon". At the end of this 10 day workshop, two groups presented their results to the Director of Science of ESA, Dr. Roger Bonnet, and other high-level representatives of the European space community.

After these presentations, Dr. Bonnet challenged the participants of the Summer School to build a small lunar orbiter. The LunarSat Proposal was the answer of the Alpbach participants to this challenge.

In October 1996, the LunarSat Proposal was presented to the ESA Long-Term Space Policy Committee (LSPC) in Paris. As a result, the ESA Council and the ESA Director General recommended in December 1996 that a co-operation between LunarSat and the EuroMoon initiative should be investigated.

During its December 1996 meeting, the ESA Council approved an initial six months study of EuroMoon. The EuroMoon core team, based at ESA-ESTEC and consisting of representatives of the major European space companies, ESA-ESTEC, ESA-ESOC, and two LunarSat Team members, conducted the EuroMoon Feasibility Study between April and November 1997. Funding for EuroMoon is to be decided by the ESA Council in December 1997. Unfortunately, the EuroMoon-project was shut down in March 1998.

¹ Currently Institute of Astronomy, University of Innsbruck, Technikerstr.25, 6020 Innsbruck, Austria-europe.
E-mail: gernot.e.groemer@uibk.ac.at



2. Aims of the LunarSat Project

It is the goal of the LunarSat Team to design and build the micro-spacecraft LunarSat for a launch to the Moon by the year 2000 with the support of ESA, research institutions, and space companies from around Europe.

This project is to be coordinated with ongoing lunar exploration efforts in other nations and space agencies. The objectives of the LunarSat Project can be divided into three categories:

Scientific Objectives

- Obtain a high resolution map of the lunar south pole region
- Investigate the lunar exosphere, magnetic fields, and / or plasma environment
- Improve the knowledge of the lunar gravity field

Educational Objectives

- Provide students and young graduates with a chance to learn 'on the job'
- Enhance the connections and interactions between ESA, the European space industry, and universities in order to provide an excellent training opportunity for students, young scientists and engineers.

Technological objectives

- Prove the feasibility of designing and building a low-cost lunar micro-orbiter within a 3 year schedule



3. Mission Design

Launch

The main consideration for LunarSat launcher selection is that it must be at low cost. The only European launchers available are the Ariane 4 and 5. To be able to meet the low-cost and the mission objectives, the only possibility is to use an Ariane 5 piggyback launch opportunity.

The Ariane 5 ASAP (Ariane Structure for Auxiliary Payload) allows for the launch and deployment of mini- and micro-satellites on a standard geostationary transfer orbit (GTO) mission dedicated to a 'Main Passenger'. The maximum mass of a single auxiliary payload is 100 kg. The nominal maximum envelope for an ASAP payload is 600 x 600 x 800 mm³. Therefore, the reference design for the LunarSat spacecraft is the launch on an Ariane 5 into GTO.

From there, the LunarSat propulsion system will provide the capability for trans-lunar injection (TLI) and injection into an elliptical lunar polar orbit.

Other launch opportunities like, for example, the Molnija launcher of the Russian Space Agency (RKA) have been considered. Using one of these launchers would require a totally different mission concept. In particular, any other launcher would require / permit a completely

different spacecraft envelope and a much higher spacecraft mass. Given the budget constraints, an Ariane 5 ASAP launch was therefore considered the only viable option.

The launch time for LunarSat is considered to be within a launch window of an Ariane 5 geostationary mission via GTO. Arianespace requires daily common launch windows of at least 45 minutes, thus allowing a second launch attempt. The most stringent constraint of a geostationary satellite mission is the solar aspect constraint for the apogee motor firing. The opening of a launch window is obtained considering a 65° solar aspect angle with respect to a reference apogee motor firing attitude. This leads to a daily 45 minutes launch window around 11:00 pm (Kourou local time).

Strategies for Lunar Transfer

There are several methods of transfer from GTO to a lunar orbit. The exact conditions of the GTO in space and time will determine which of these options will be the most efficient one. Maximum trans-lunar injection (TLI) maneuver efficiency is achieved by a coplanar tangential thrust. In this case, the lunar transfer orbit (LTO) is obtained by a perigee maneuver raising the GTO apogee to the distance of the Moon.

This means that GTO and LTO need to have nearly the same orbital orientation. Due to the rotation of its line of nodes, the orbit of the Moon is inclined between 18° and 29° with respect to the Earth's equatorial plane. Thus, the Moon can only be reached, without any inclination change, when the Moon is positioned at its nodes and the Sun is aligned with the nodal line of the Moon's orbit. This special geometrical situation occurs only twice per year.

It is not desirable to remain in GTO for extended periods, as repeated passage through the Van Allen Belts subjects the spacecraft to high levels of radiation. If up to 60 days are spent in GTO, the line of apsides can only be rotated through 24° . This then sets the opportunity for just two daily launch windows of about 100 minutes each.

Assuming the launch into GTO is near midnight, there are only two seasons per year with this type of launch opportunity. In order to extend these windows, either fuel must be used to rotate the orbit deliberately, or a different approach must be adopted employing solar perturbations in a highly eccentric orbit (weak-stability boundary trajectory).

Strategies for Lunar Orbit

Lunar Orbit - General Considerations

It is the aim of the LunarSat Project to map the surface of the Moon, in particular, the lunar south pole region. In its operational orbit, LunarSat wants to achieve a maximum life time while minimizing fuel requirement. The specific parameters of candidate operational orbits need to be evaluated as a function of the key mission requirements. The lunar orbit parameters (inclination, eccentricity, and altitude) will dictate the type of surface coverage and resolution that can be realized.

Orbital inclination strongly influences the quality of regional surface coverage. Mapping of the entire lunar surface is only reasonable from a polar orbit. A disadvantage of lunar polar orbits is the limited coverage of low-latitude regions where successive orbital tracks are far apart.

Reducing orbital inclination from a 90° (polar) orbit improves the coverage at low latitudes and equatorial regions, but completely eliminates polar coverage. Orbit altitude selection is primarily a function of required instrument resolution, viewing needs, and concerns for orbital stability.

A highly elliptical lunar orbit can provide a high-resolution mapping capability without the stability problems associated with low circular orbits. Such an orbit offers a variety of surface-coverage opportunities through the proper choices of perilune latitude and orbit eccentricity. The drawback is the small region of coverage on the apolune side (maximum distance from the surface).

Delta-V Summary

The D v-requirement for lunar transfer vary slightly with the transfer strategy. The reference D v-requirements for LunarSat are listed in Table 1.

Operation	delta-V (m/s)
GTO-LTO	750
LTO-Mid Course Manoeuvre	300
LTO-LO	450
Total:	1500

Table 1: Delta-v reference requirements

Assuming a mission duration of 180 days in lunar orbit, the reference D v-requirement for the attitude and orbit control system of LunarSat is listed in Table 2.

Operation	delta-V (m/s)
Lunar Orbit Maintenance	150
Attitude Control	100
Total:	250

Table 2: Delta v-requirements for Maintenance



4. System Design - General Aspects

LunarSat is designed by young engineers, scientists, and students located all over Europe. All elements and documents of the basic system design are digitally transferable to all members to obtain comments and ideas. The LunarSat system design has been developed based on an integrated spreadsheet model using commercial off-the-shelf software.

A special format for the LunarSat Integrated Model (LIM) has been developed to make it easier to integrate the individual works of the LunarSat Team members and to work in a very modular fashion. Subsystem developments are conducted using other commercial software tools, e.g. ProEngineer for structure and layout, and other dedicated software codes.



5.Spacecraft Configuration

LunarSat is a box-shaped satellite with a volume of $640 \times 640 \times 800 \text{ mm}^3$. On top of the spacecraft, a high-gain patch antenna is located. Two of the side panels are covered with solar arrays. On a third side panel, the instruments and camera are placed, and on the fourth sider side thermal radiator is located.

The main thruster and the Ariane 5 separation system are located on the bottom side of the spacecraft, with the nozzle placed inside the ASAP separation ring.

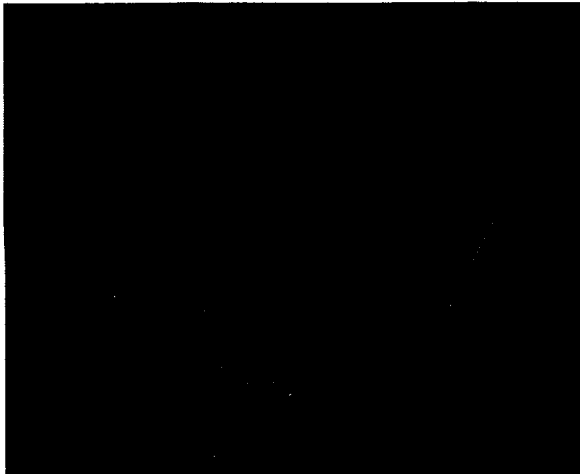

Fig.1: Scetch of the LunarSat Orbiter

5.1 Spacecraft Structure

The ability of the spacecraft to withstand an Ariane V piggyback launch is ensured by dimensioning the structure according to the requirements given in the Ariane 5 ASAP User Manual, and taking

into account a safety factor of 1.5. A Finite Element (FE) model of LunarSat is currently being developed in cooperation with the Chair of Lightweight Construction of the Technische Universität München, using a NASTRAN software package. With the help of the FE model, the dynamics of the LunarSat spacecraft will be examined.

5.2 Propulsion System

The propulsion system must be able to transfer LunarSat from GTO to a lunar polar orbit. The total velocity requirement is about 1500 m/s delivered over 3 principal maneuvers. A Dual Mode system has been selected as the reference propulsion system for LunarSat.

5.3 Power System

LunarSat will be powered by two body-mounted solar panels consisting of Si-cells, both during the transfer phase and in orbit around the Moon. These panels will be mounted on two perpendicular sides of the satellite. These sides will be directed towards the Sun to provide the necessary power with some flexibility of the solar angle in one plane.

The total power requirement of the arrays is estimated at 32 W (EOL). The required total panel area is in the order of 0.49 m^2 . The total mass of the solar array including harness and connectors is approximately 1.7 kg.

5.4 Ground Segment and Operations

Spacecraft operations includes all activities which a team of operators perform to command and control the spacecraft. The LunarSat mission from launch until orbit insertion consists out of seven mission phases:

- Separation from Ariane 5 ASAP
- Acquisition of orientation and position
- Waiting for launch window to open
- Injection into Lunar Transfer Orbit
- Midcourse maneuvers
- Injection into a highly elliptical lunar orbit
- Nominal operations in lunar orbit

LunarSat website:

<http://lunarsat.lrt.mw.tu-muenchen.de>

References

- LunarSat Users Manual (upon request from Author)
- LunarSat Integrated Model (LIM) documentation (limited access on request)

The ground stations are used to communicate with the spacecraft, sending and receiving data to and from the satellite and its instruments. It is necessary to determine several ground station locations, based on spacecraft coverage and data user needs, whereby the accessibility and availability of the ground stations / antennas need to be investigated. Due to the fact that LunarSat is a low budget program, only suitable existing ground stations and their equipment are considered. These include, e.g. the centers in Darmstadt (ESOC), Weilheim, Perth, Villafranca, Kourou, and Vilspa.

Contact Information:

Lunarsat Project Team

Gernot E. Groemer

Institute of Astronomy
at the University of Innsbruck
Technikerstr.25/8
6020 Innsbruck, Austria – europe
Tel.: 0043 – 512 – 507/6041
Fax.: 0043 – 512 – 507/2923

LUNARSAT SEARCHING FOR THE SOUTH POLAR COLD TRAPS

Gernot E. Groemer¹
LunARSat Project Team

Abstract

LunARSat (Lunar Academic Research Satellite) is a micro-spacecraft that will be sent into an orbit around the Moon to perform scientific investigations on the lunar environment and its characteristics. LunARSat is designed by young engineers, scientists, and students from around Europe, with support from numerous institutions and space industry. It shall be launched as an auxiliary payload on an Ariane 5 ASAP platform and will have a mass of 100 kg in GTO. LunARSat will orbit the Moon on a highly elliptical polar orbit with its perigee above the lunar south pole area. This orbital strategy yields the possibility to obtain images of the lunar south pole region with a resolution never achieved before.



1. Mission Background

The history of the LunARSat Project dates back to July 1996 when 52 students, young scientists and engineers from 15 different European countries gathered in Alpbach, Austria, for the ESA Summer School "Mission to the Moon". After this workshop Dr. Roger Bonnet, the Director of Science of ESA, challenged the participants of the Summer School to build a small lunar orbiter. The LunARSat Proposal was the answer of the Alpbach participants to this challenge.

In October 1996, the LunARSat Proposal was presented to the ESA Long-Term Space Policy Committee (LSPC) in Paris. As a result, the ESA Council and the ESA Director General recommended in

December 1996 that a cooperation between LunARSat and the EuroMoon initiative should be investigated. During its December 1996 meeting, the ESA Council approved an initial study of the EuroMoon concept. The EuroMoon core team and two LunARSat Team members, conducted a Feasibility Study starting in April 1997, until March 1998, when the EuroMoon project was stopped.

The Institute of Astronautics of the Technische Universität München, Germany developed into the engineering center of the LunARSat Project. Supported by the local space industry, a team of 20 professors, research assistants, and students have been working on LunARSat since early 1997. The Munich engineering group was also supported by several members of the Alpbach group in different European countries.

¹ Currently Institute of Astronomy, University of Innsbruck, Technikerstr.25, 6020 Innsbruck, Austria-europe.
E-mail: gernot.e.groemer@uibk.ac.at

The LunARSat science efforts are being coordinated by the Swedish Institute for Space Physics in Uppsala which essentially became the LunARSat science center. Surrey University, bringing a significant expertise on small satellite technology, joined these two institutions in autumn 1997.



2. Scientific Background

The Moon provides us with an archaeological playground of an object at an age of 4.5 billion years, which apart from very modest human activity only has been affected by the interaction with the space environment. Comets in our solar system consist of water ice, and the Moon like any other major body in the solar system is continuously bombarded by them. In the sunlit areas the water is vaporized and eroded by the solar wind. In contrast, the lunar south pole area is never reached by sunlight and therefore remains cold enough to preserve ice from earlier comet bombardment in so-called "cold-traps" at a temperature of roughly 40 K².

The Clementine³ and Lunar Prospector⁴ missions showed evidence for lunar ice.

² K. Watson, B.C. Murray, H. Brown, J.Geophys.Res. 66, 3033 (1961); J.R. Arnold, ibid. 84,5659 (1979)

³ S. Nozette, P.Rustan et.al, Science 266, 1835 (1994)

⁴ <http://lunar.arc.nasa.gov/science/results/lunarice/eureka.html>

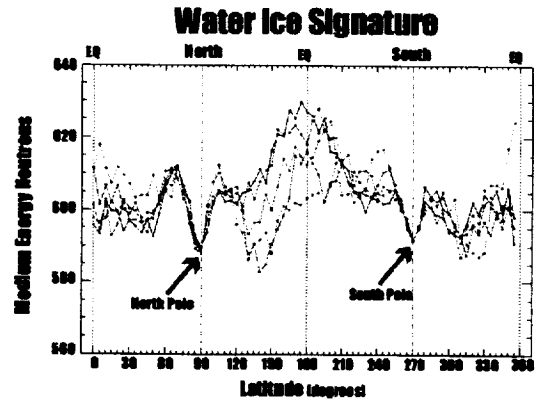
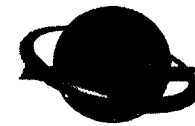

Figure 1: Water signature discovered by the Prospector s/c.



3. Aims of the LunARSat Project

It is the goal of the LunARSat Team to design and build the micro-spacecraft LunARSat for a launch to the Moon by the year 2000 with the support of ESA, research institutions, and space companies from around Europe.

This project is to be coordinated with ongoing lunar exploration efforts in other nations and space agencies. The objectives of the LunARSat Project can be divided into four categories:

Programmatic objectives

- demonstrate Pan-European academic collaboration
- to serve as a precursor mission for future lunar exploration
- to support cooperation in a multinational and multidisciplinary environment
- to enhance the scientific and industrial connectivity between the European Space Agency, european industry and universities

Scientific Objectives

- to verify and study the Lunar South Pole ice resources with high resolution capabilities as well as radar investigations
- to investigate the pristine lunar environment with respect to its plasma- and exosphere

Technical Objectives

- to develop, build and integrate europe's first lunar micro-orbiter
- to gain knowledge in the field of micro-satellite technology
- to promote spin-offs for space related activities

Educational Objectives

- to provide young professionals with hands-on experience in a small space project
- to increase the interest of the growing-up

generation in space science and science in general, by making the project transparent via Internet and multimedia tools

- to effectively make use of network interactions



4. Mission Design

Launch

The main consideration for LunARSat launcher selection is that it must be at low cost. The only European launchers available are the Ariane 4 and 5. To be able to meet the low-cost and the mission objectives, the solution is to use an Ariane 5 piggyback launch opportunity.

The Ariane 5 ASAP (Ariane Structure for Auxiliary Payload) allows for the launch and deployment of mini- and micro-satellites on a standard geostationary transfer orbit (GTO) mission dedicated to a 'Main Passenger'. The maximum mass of a single auxiliary payload is 100 kg. The nominal maximum envelope for an ASAP payload is 600 x 600 x 800 mm³. Therefore, the reference design for the LunARSat spacecraft is the launch on an Ariane 5 into GTO.

From there, the LunARSat propulsion system will provide the capability for trans-lunar injection (TLI) and injection into an elliptical lunar polar orbit.

Other launch opportunities like, for example, the Molnija launcher of the Russian Space Agency (RKA) have been considered. Using one of these launchers would require a totally different mission

concept. In particular, any other launcher would require / permit a completely different spacecraft envelope and a much higher spacecraft mass. Given the budget constraints, an Ariane 5 ASAP launch was therefore considered the only viable option.

The launch time for LunARSat is considered to be within a launch window of an Ariane 5 geostationary mission via GTO. Arianespace requires daily common launch windows of at least 45 minutes, thus allowing a second launch attempt. The most stringent constraint of a geostationary satellite mission is the solar aspect constraint for the apogee motor firing. The opening of a launch window is obtained considering a 65° solar aspect angle with respect to a reference apogee motor firing attitude. This leads to a daily 45 minutes launch window around 11:00 pm (Kourou local time).

Strategies for Lunar Transfer

There are several methods of transfer from GTO to a lunar orbit. The exact conditions of the GTO in space and time will determine which of these options will be the most efficient one. Maximum trans-lunar injection (TLI) maneuver efficiency is achieved by a coplanar tangential thrust. In this case, the lunar transfer orbit (LTO) is obtained by a perigee maneuver raising the GTO apogee to the distance of the Moon.

This means that GTO and LTO need to have nearly the same orbital orientation. Due to the rotation of its line of nodes, the orbit of the Moon is inclined between 18° and 29° with respect to the Earth's equatorial plane. Thus, the Moon can only be reached, without any inclination change, when the Moon is positioned at its nodes and the Sun is aligned with the nodal line of

the Moon's orbit. This special geometrical situation occurs only twice per year.

It is not desirable to remain in GTO for extended periods, as repeated passage through the Van Allen Belts subjects the spacecraft to high levels of radiation. If up to 60 days are spent in GTO, the line of apsides can only be rotated through 24°. This then sets the opportunity for just two daily launch windows of about 100 minutes each.

Assuming the launch into GTO is near midnight, there are only two seasons per year with this type of launch opportunity. In order to extend these windows, either fuel must be used to rotate the orbit deliberately, or a different approach must be adopted employing solar perturbations in a highly eccentric orbit (weak-stability boundary trajectory).

Delta-V Summary

The D v-requirement for lunar transfer vary slightly with the transfer strategy. The reference D v-requirements for LunARSat are listed in Table 1.

Operation	delta-V (m/s)
GTO-LTO	750
LTO-Mid Course Manoeuvre	300
LTO-LO	450
Total:	1500

Table 1: Delta-v reference requirements

Assuming a mission duration of 180 days in lunar orbit, the reference Δv -requirement for the attitude and orbit control system of LunARSat is listed in Table 2.

Operation	Δv (m/s)
Lunar Orbit Maintenance	150
Attitude Control	100
Total:	250

Table 2: *Delta v-requirements for Maintenance*



5. Onboard Experiments

One of LunARSat's objectives is to gain data on the lunar south pole regions as well as do measurements of the magnetospheric environment of the Moon. Clementine did a similar mapping, but this was performed under bad light conditions due to orbital and time constraints. So the real extension of the eternally shadowed areas in the south pole regions remains unknown.

These questions are being investigated by two experiments.

Camera

High resolution, multispectral and stereo imaging of the lunar south pole region and other selected areas as well as monitoring seasonal changes of the illumination in the polar regions is being performed by a multipurpose camera with a spectral range between 400 to 1000 nm

(visible to infrared).

The High Resolution camera consists of a 400mm catadioptric system providing a resolution of 3,5 meters on the poles, and even more detailed sub-meter resolution after having lowered the orbit.

The shadow mapping is done by a 14mm focal length optical system, the total camera weight is as low as 35 g (including optics), giving a field of view of 40 Degrees. This system will be able to overview a large part of the south pole region and therefore be able to perform a unique shadow mapping throughout the entire mission.

Radio Experiment (REX)

The Radio and Plasma Experiment (REX) will contribute to the study of the lunar plasma environment, and possibly also give information regarding the surface and even subsurface materials and structure near the south pole of the Moon. The solar wind hitting our trabant forms a density cavity downstream on the dark side of the Moon. The plasma dynamics and structure and emissions can readily be monitored by REX, both in-situ (passive) and remotely (active). In particular, the extent and structure of the lunar ionosphere can be determined.

LunARSat is planned to be simultaneously operational with the ESA cornerstone Cluster II mission, which aims to investigate the magnetospheric dynamics and space weather effects, where the Moon plasma may be one such effect when the lunar orbit crosses the plasma tail of the Earth.

The baseline REX comprises a Radar Antenna System with six 5 meter long elements spanning three dimensions, which can be operated both in passive sampling

mode and active radar modes, as well as one classical Langmuir probe (LP) ontop a 1 meter long boom for measurements of the local plasma density and electron temperature. The passive mode monitors plasma irregularities, emissions, and electric fields, while the active mode can be used either as a coherent radar versus plasma irregularities and sharp density gradients, or as an “ionospheric” sounder. Together with an Magnetometer and Sodium counter it forms a powerful exospheric package.

The technical characteristics of REX are as follows:

Radar Antenna System

- Electric field in the range 0,01 mV/m – 1 V/m, 0,05 kHz – 5 MHz
- “Magnetospheric” mapping of plasma irregularities and density gradients/structures out to about 1000 km from the spacecraft
- Topside sounding of the lunar “ionosphere”, critical frequency 50-500 kHz
- Radar ground penetration and altimetry of the surface/subsurface of the Moon

Langmuir probe

- Electron density $1-10^6 \text{ cm}^{-3}$
- Electron temperature 0,001/10 eV
- Electron desnity fluctuations $(\Delta n)/n$ 0,1-50%
- Spacecraft potential
- Plasma oscillations 0-100 kHz
- Solar UV integrated ionizing flux
- Dust and micrometeroid impacts of μm sized particles on spacecraft

- Ion flow direction



6. System Design - General Aspects

LunARSat is designed by young engineers, scientists, and students located all over Europe. All elements and documents of the basic system design are digitally transferable to all members to obtain comments and ideas. The LunARSat system design has been developed based on an integrated spreadsheet model using commercial off-the-shelf software.

Subsystem developments are conducted using other commercial software tools, e.g. ProEngineer for structure and layout, and other dedicated software codes.

A special format for the LunARSat Integrated Model (LIM) has been developed to make it easier to integrate the individual works of the LunARSat Team members and to work in a very modular fashion, as most of the team members are spread over several countries. Therefore, LunARSat will be the first “virtually designed s/c” welcoming the next millenium.

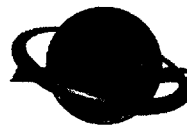

7. Spacecraft Configuration

LunARSat is a box-shaped satellite with a volume of $640 \times 640 \times 800 \text{ mm}^3$. On top of the spacecraft, a high-gain patch antenna

is located. Two of the side panels are covered with solar arrays. On a third side panel, the instruments and camera are placed, and on the fourth side thermal radiator is located.

The main thruster and the Ariane 5 separation system are located on the bottom side of the spacecraft, with the nozzle placed inside the ASAP separation ring.



Fig.2: Sketch of the LunARSat Orbiter

7.1 Spacecraft Structure

The ability of the spacecraft to withstand an Ariane V piggyback launch is ensured by dimensioning the structure according to the requirements given in the Ariane 5 ASAP User Manual, and taking into account a safety factor of 1.5. A Finite Element (FE) model of LunARSat is currently being developed in cooperation with the Chair of Lightweight Construction of the Technische Universität München, using a NASTRAN software package. With the help of the FE model, the dynamics of the LunARSat spacecraft will be examined.

7.2 Propulsion System

The propulsion system must be able to transfer LunARSat from GTO to a lunar polar orbit. The total velocity requirement is about 1500 m/s delivered over 3 principal maneuvers. A Dual Mode system has been selected as the reference propulsion system for LunARSat.

7.3 Power System

LunARSat will be powered by two body-mounted solar panels consisting of Si-cells, both during the transfer phase and in orbit around the Moon. These panels will be mounted on two perpendicular sides of the satellite. These sides will be directed towards the Sun to provide the necessary power with some flexibility of the solar angle in one plane.

The total power requirement of the arrays is estimated at 32 W (EOL). The required total panel area is in the order of 0.49 m². The total mass of the solar array including harness and connectors is approximately 1.7 kg.

7.4 Ground Segment and Operations

Spacecraft operations includes all activities which a team of operators perform to command and control the spacecraft. The LunARSat mission from launch until orbit insertion consists out of seven mission phases:

- Separation from Ariane 5 ASAP
- Acquisition of orientation and position
- Waiting for launch window to open
- Injection into Lunar Transfer Orbit

- Midcourse maneuvers
- Injection into a highly elliptical lunar orbit
- Nominal operations in lunar orbit

The ground stations are used to communicate with the spacecraft, sending and receiving data to and from the satellite and its instruments. It is necessary to determine several ground station locations, based on spacecraft coverage and data user needs, whereby the accessibility and availability of the ground stations / antennas need to be investigated. Due to the fact that LunARSat is a low budget program, only suitable existing ground stations and their equipment are considered. These include, e.g. the centers in Darmstadt (ESOC), Weilheim, Perth, Villafranca, Kourou, and Vilspa.

LunARSat website:

<http://LunARSat.lrt.mw.tu-muenchen.de>

References

- LunARSat Users Manual (limited access upon request)
- K. Watson, B.C. Murray, H. Brown, J.Geophys.Res. 66, 3033 (1961); J.R. Arnold, ibid. 84,5659 (1979)
- S. Nozette, P.Rustan et.al, Science 266, 1835 (1994)
- Mission Homepage of Lunar Prospector: <http://lunar.arc.nasa.gov/science/>

Contact Information:

LunARSat Project Team

Gernot E. Groemer

Institute of Astronomy
at the University of Innsbruck
Technikerstr.25/8
6020 Innsbruck, Austria – europe
Tel.: 0043 – 512 – 507/6041
Fax.: 0043 – 512 – 507/2923

ASTEROID HAZARDS—AN ASSESSMENT OF CURRENT SURVEY AND ALERT STRATEGIES

Gernot E. Groemer¹

Abstract

Asteroids and comets impacts have been widely regarded as phenomena only happening in the early solar system during the so-called “Early bombardement”, billions of years ago. Detailed surveys, theoretical analysis as well as the collision of comets with Jupiter and the sun have shown, that the Earth is subjected to a continuing “celestial rain”. The intention of this article is to give an up-to-date overview on major observational campaigns as well as the standard procedures if a new asteroid/comet is discovered.

1. Introduction

Near Earth Objects (NEO) have been discovered to impose a potential hazard to the Earth. An impact by an object or comet larger than 1km in diameter, occurring every 100 000 years, could cause a serious threat to human civilization. Although the consequences of such an event are immense, there exist two reasons, why this topic has failed to enter the arena of natural hazard policy unlike common disasters such as floods, earthquakes and others.

First, the threat is a relatively new one: two decades ago only a very limited number of Planetologists began to understand that a significant amount of earth’s trajectory crossing objects the solar system exist. Further, it is difficult – from a standpoint of disaster management organizations (like the Federal Emergency Management Agency (FEMA))- to deal with threats that have never happened since the beginning of human records.

Secondly, due to the extremely unusual appearance of the disaster (extremely high consequences as opposed to extremely little probability) as well as a wide gap between the knowledge of the scientific community and the natural hazards community and the general public. This includes the different perceptions of how to handle the statistics involved in collision warnings.

Therefore – despite events with wide media coverage such as the collision of comet Shoemaker-Levy 9 with Jupiter 1993, the discovery of the Yucatan impact

¹ Institute for Astronomy at the University of Innsbruck. Technikerstr.25/8-6020 Innsbruck, Austria. E-mail: gernot.e.groemer@uibk.ac.at

crater(s)², two movies and several close approaches of NEO's - in times of budget-cutting it doesn't surprise that several observational campaigns have been downsized or even shut down.

All present observation campaigns for small planetary bodies together provide a discovery rate of several thousands objects per year, about 0.1% of these are Near Earth Asteroids.

Figure 1 gives an impression, how often impactors of a given size collide with our planet. It is widely believed, that a bolide having the size of more than 1 km can cause effects such as worldwide earthquakes, tsunamis and volcanic eruptions, acid rains over weeks or months, worldwide fires and nuclear winter effects. These activities destroy the food chain and cutting down the maximum weight of animals to be sustained by crops to 25 kg living weight.

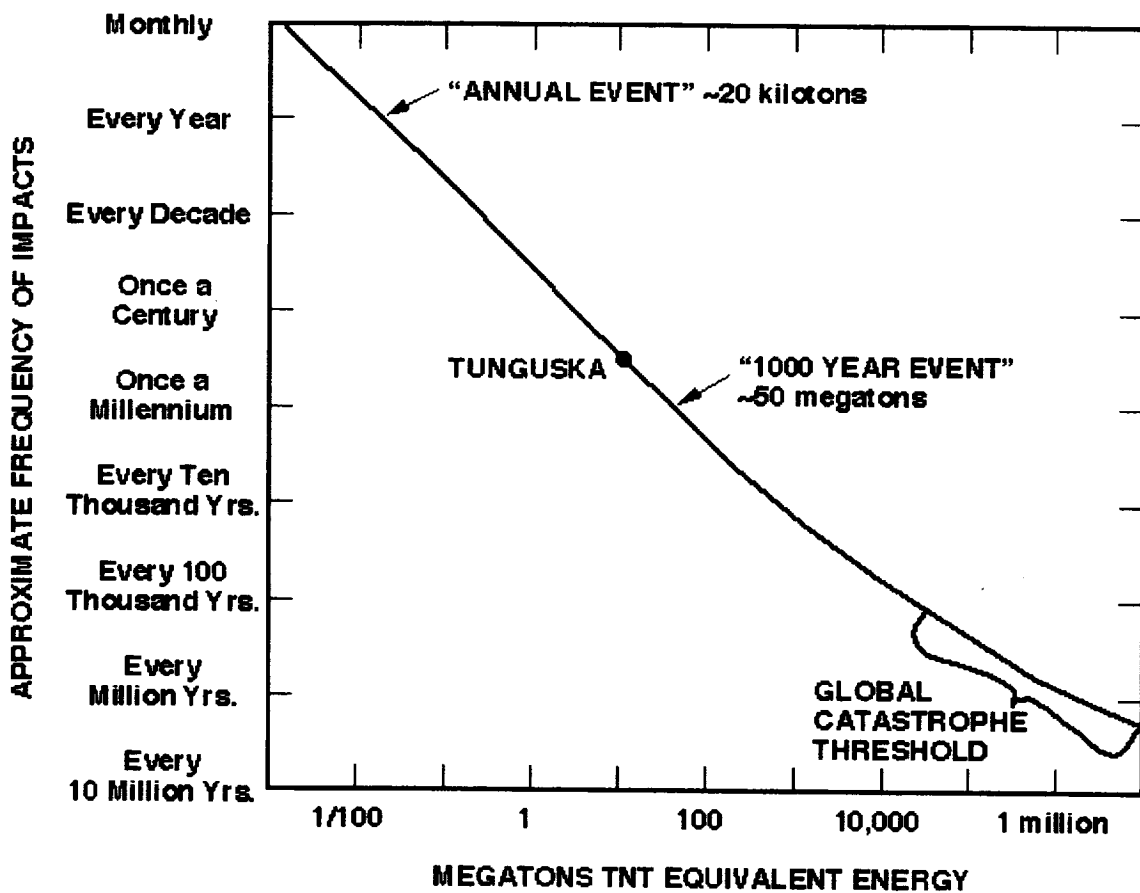

Figure 1: Impact Probabilities (taken from Spaceguard Survey Report)

² This impact is widely regarded to be the "smoking-gun"-evidence of the catastrophic collision that wiped out 80% of the living species at the end of the cretaceous period, including the dinosaurs. (Alvarez, 1992)

2. Current campaigns

At the moment, there are only three major and several smaller systematic efforts to search for NEO's underway. However, it is interesting to note, that all these surveys are being done in the northern hemisphere, leaving the southern skies "terrae incognitae" (unknown regions).

2.1 Planet-Crossing Asteroid Survey (PCAS)³

The PCAS survey for Earth-crossing and other planet-crossing asteroids was initiated by E.F. Helin and E.M. Shoemaker in 1973 and is now directed by Helin. It is the longest running dedicated search program for the discovery of near-Earth asteroids and is carried out with the 0.46-m Schmidt telescope at Palomar Observatory in California. Early in the survey, about 1000 square degrees of sky were photographed each month. In the last ten years, the use of fast film has allowed shorter exposures leading to greater sky coverage.

This fact, in combination with a custom-made stereomicroscope, has resulted in a five-fold increase in the discovery rate over the early years of the program. Using the stereo pair method, up to 4000 independent square degrees of sky can be photographed per month. This program has been particularly successful in getting out early alerts on new discoveries so physical observations can be obtained during the discovery apparition. There has also been an organized international aspect to this program, called the International Near-Earth Asteroid Survey (INAS), which attempts to expand the sky coverage and the discovery and recovery of NEAs (Near Earth Asteroids) around the world.

2.2 The Palomar Asteroid and Comet Survey (PACS)

A second survey with the Palomar 0.46-m Schmidt was begun by E.M. and C.S. Shoemaker in 1982 and has continued with the collaboration of H.E. Holt and D.H. Levy. About 3000 square degrees of sky are photographed each month. Both the PACS and PCAS programs center their sky coverage at opposition and along the ecliptic and attempt to cover as much sky as possible in every 7-night observing run at the telescope. The two programs combined produce about 6000 independent square degrees of sky coverage per month.

³ PCAS and PACS description is partly taken from the Spaceguard Survey which can be found at: http://ccf.arc.nasa.gov/sst/spaceguard/sg_4.html

2.3 The Anglo-Australian Near-Earth Asteroid Survey (AANEAS) (shut down in 1996)

This initiative operated from 1990-1996 under the guidance of D.I. Steel, R.H. McNaught and K.S. Russell, becoming one of the most prolific programs of its type in the world⁴. Apart from leading to the discovery of 38 Near Earth Asteroids, 9 comets, 63 supernovae, several other astronomical phenomena, and the delivery of a substantial proportion of all NEA astrometry obtained worldwide.

The Anglo-Australian Near-Earth Asteroid Survey operated from early 1990 through to the end of 1996. It was based on the Anglo-Australian Observatory (AAO) telescope site near Coonabarabran but made also use of telescopes operated as part of Siding Spring Observatory, which is co-located in the Warrumbungle Mountains 25 kilometers west of Coonabarabran. The limiting magnitude was 22nd with a coverage rate of 2500 square degrees per month.

2.4 OCA-DLR Asteroid Survey (O.D.A.S.)⁵

O.D.A.S. is a dedicated french-german program to search for asteroids and comets, with special emphasis on NEO's within the framework of the EUNEASO project, in cooperation and support of global efforts in NEO-research. It has been initiated by the WGNEO (Working group on Near Earth Objects) of the IAU (International Astronomical Union), and the Spaceguard Foundation. The survey is operated at the 90cm Schmidt-telescope of the OCA at Calern, north of Nice, in southern France, as a joint venture between the OCA - Observatoire de la Côte d'Azur, Nice, France and the DLR⁶ -Institute of Planetary Exploration, Berlin-Adlershof, Germany. The current system uses a 2k CCD camera in combination with an automated asteroid detection software package. O.D.A.S. began observations in October 1996 and observes for about 15 nights each month using the weeks of first and last quarter of the Moon.

2.5 Space-Based Operations

Since the launch of the first Global Positioning System Satellite, the Global Verification and Location System (GVLS) has been in operations. This system provides visible sensors capability to detect nuclear detonations and meteoritic impacts. However, these instruments only report signals that meet a specific, rather narrow set of threshold

⁴ The final report of the campaign can be found at <http://www1.tpgi.com.au/users/tps-seti/spacegd4.html>

⁵ <http://pentium.pe.ba.dlr.de/odas/odas.htm>

⁶ DLR is the German aerospace establishment. (Deutsche Gesellschaft fuer Luft- und Raumfahrt)

criteria. Because the majority of meteoroidal impacts will not meet those criteria, the satellite will discard them⁷.

However, there still remains a potential political hazard due to misinterpreted impact. It happened in the past and it will happen again, that Defense organizations are being mis-alerted, which poses a significant additional threat to crises.

2.6 Other

A recent addition to these programs is the Xinglong⁸ initiative from China and another survey that is being undertaken by French astronomers.

By the end of 1998, the Klet Observatory, Czech Republic/Europe will undertake a major effort with a 1.02 m telescope. Up to now they already discovered around 350 NEO's⁹. Ondrejov NEO Photometric Survey is another Czech initiative, mainly focused on the follow-up observations¹⁰.

Another effort is being carried out by the NEAT-program¹¹ as well as another US Air Force telescope. The Air Force Research Laboratory (AFRL) operating location on Maui has a two-fold mission. First, it conducts the research and development mission on the Maui Space Surveillance System (MSSS) at the Maui Space Surveillance Complex (MSSC). Second, it oversees operation of the Maui High Performance Computing Center (MHPCC) which is located in the Maui Research and Technology Park in the town of Kihei. AFRL's research and development mission on Maui was formally called AMOS; the use of the term AMOS has been widespread throughout the technical community for over thirty years and is still used today at many technical conferences.¹²

⁷ E. Tagliaferri, R. Spalding, C. Jackobs, S.P. Worden, A. Erlich: Detection of Meteoroid Impacts by Optical Sensors in Earth Orbit, in: T. Gehrels (Editor): "Hazards due to Comets and Asteroids", Univ. of Arizona Press, 1994.

⁸ <http://vega.bac.pku.edu.cn/~zj/scap/scap.html>

⁹ <http://www.ipex.cz/klet/metr.html>

¹⁰ <http://sunkl.asu.cas.cz/~ppravec/>

¹¹ <http://huev.jpl.nasa.gov/~spravdo/neat.html>, NEAT is an autonomous celestial observatory located at the USAF/Ground-based Electro-Optical Deep Space Surveillance (GEODSS) site on Haleakala, Maui, Hawaii. NEAT is a cooperative effort between the National Aeronautics and Space Administration/Jet Propulsion Laboratory and the United States Air Force.

¹² The Maui Space Surveillance Complex (MSSC) is a multi-faceted observatory owned by Air Force Space Command. Day-to-day operations of the site are conducted by the 18th Space Surveillance Squadron Detachment 3, the host organization. The MSSC is situated in the mid-Pacific at the ten-thousand-foot summit of Haleakala and is unsurpassed as an electro-optical site for tracking man-made objects in space, and for conducting experiments which expand the frontiers of our nation's space surveillance program. Due to this high elevation, dry climate, and freedom from light pollution, the site offers virtually year-round observation of satellites, missiles, man-made orbital debris, and astronomical objects. This national resource is a primary asset of the Space Surveillance Network. Its telescopes fall into two distinct groups: the Maui Space Surveillance System (MSSS) and the Ground-Based Electro-Optical Deep Space Surveillance (GEODSS) telescopes.

The Catalina Sky Survey¹³ (formerly: the Bigelow Sky Survey) at the Lunar and Planetary Lab, University of Arizona uses the Steward Observatory Catalina Station 42 cm Schmidt camera with a CCD. The instrumentation is currently being adjusted and calibrated, and detection software written. With the addition of appropriate computer capacity, it will routinely begin the survey by the fall of 1998.

In April 1998, the Japanese government announced the building of a dedicated 1m class telescope for NEO-surveys. Amateur astronomers, mainly in Europe and Japan, significantly contribute to worldwide observation efforts.

3. Data collection and processing

3.1 Search Techniques

The vast majority of NEO's has been found on photographic plates. The reason for this is the type of telescope used (Schmidt-wide angle telescopes), which have a long tradition of high-resolution photoplates. Secondly, there are numerous findings on historic plates, like on the Palomar Observatory Sky Survey (POSS). As the first systematic searches began, there were no large field-of-view CCD chips commercially available, typical Chip sizes were 320 x 512 (RCA-chip), which have proved to be too small for efficient surveys. In the early 90ies, Hardware like the Tektronix 2048 x 2048 CCD made the use of such electronic devices possible.

Combining current databases with theoretical models, we can make a rough estimate of the number densities of asteroids and comets with potentially hazardous properties. Three asteroids (1915 Quetzalcoatl, 1981 Midas and 2201 Oljato) have orbits, which are definitely Earth intersecting during our century. 12 asteroids have trajectories that are planet intersecting during the same period: 1 with Mercury, 1 with Venus, the 3 with Earth and 7 with Mars. According to a model population by E. Bowell¹⁴, there are 20 asteroids having MOIDs (Minimal Orbit intersection distance) of less than 0,05 astronomical units from the Earth during the 20th century¹⁵, and 9 or 10 of those are currently protected by orbital resonances with our planet.

3.2 Central Data Acquisition

¹³ <http://www.lpl.arizona.edu/bss/>

¹⁴ E. Bowell, K. Muinonen: Earth Crossing Asteroids and Comets: Groundbased Search Strategies in: T. Gehrels (Editor): "Hazards due to Comets and Asteroids", Univ. of Arizona Press, 1994.

¹⁵ This simulation was created in 1994 for simulation purposes to make rough order of magnitude calculations of NEO detection probabilities within the Spaceguard Survey.

The object positions as soon as acquired are usually e-mailed to the Minor Planet Center (MPC), located at the Harvard-Smithsonian Center for Astrophysics. The staff can examine whether the object is already known, in the sense, that an orbit determination is already available for it. Identification is straightforward in the case of numbered minor planets and other multiple-opposition minor planets. A comparison is also made with orbits of other newly discovered objects including non-apsidal orbit trajectories¹⁶. If there is no immediately recognized match, the object is given a preliminary number (YEAR + 2 Letters, e.g. 1998 CF), and a draft orbit determination is done. Though not recommended, an orbit determination can be done within one single observation night in case of close/fast approaches/trajectories¹⁷.

As soon, as the orbital parameters are known, the International Astronomical Union (IAU) releases the Circular-Telegrams to facilitate follow-up observations¹⁸. Thus, at the moment of discovery every asteroid and comet is a potentially hazardous NEO.

The principal follow-up observatories are the Oak Ridge Observatory in Massachusetts (1,5 m mirror + CCD), the University of Victoria and Dominion Astrophysical Observatory (1,8 m telescope + CCD, Schmidt telescope) and finally, the Mt. John University Observatory (0,6m Refraction Telescope). Those institutions can make the follow-up observations even for less brighter objects. NEO's with a magnitude of 16 are easily observed by amateur astronomers, mainly in central Europe (Italy, Great Britain and Austria) and Japan.

4. The 1997 XF11 incident

The impact hazard made unprecedented inroads in public consciousness worldwide during the last half of the second week of March 1998. The first apparently "official" prediction of a significant probability of impact during our lifetimes by a dangerous asteroid gained headlines, often banner headlines, around the globe.

1997 XF11 was discovered on December 6, 1997, by Jim Scotti, observer with the Spacewatch program in Arizona. It was the brightest NEO discovered by in more than a year. Follow-up observations by Japanese amateur astronomers permitted calculation of an approximate orbit for the asteroid with a MOID (minimum orbital intersection distance with Earth) of close to zero, making it the 108th known PHA (potentially hazardous asteroid: those asteroids for which MOID <0,05 Astronomical Units, or 7,5 million km; the MOID parameter and PHA's were defined by Ted Bowell, of Lowell Observatory, and adopted by Brian Marsden, who directs the International Astronomical

¹⁶ A.Carusi et.al.: Near Earth Objects: Present Search Programs; in: T. Gehrels (Editor): "Hazards due to Comets and Asteroids", Univ. of Arizona Press, 1994.

¹⁷ Sometimes, NEO's can change their relative brightness within hours making it difficult for follow-up observations.

¹⁸ The orbital parameters also appear in the Circulars of the Minor Planet Center, but those appear only on a monthly base.

Union Minor Planet Center (MPC) in Cambridge, Massachusetts. That classification placed XF11 higher on observers' priority lists, but the orbit was too poorly known to predict a close approach to Earth, as later analysis has shown.

Rough calculations indicated at the time, the object would come close to our planet. Based on this information, the MPC released a urgent IAU circular plus – to handle the expected media questions - a press release. The next day, the worldwide media announced another doomsday threat. Higher sophisticated analysis showed that there were errors in the initial orbital calculations. Certainly, there has been done a significant damage to the credibility of science in general and planetology in specific.

This incident was an example (not the only one) of too hastily released scientific information. Unfortunately, the media are not judging astronomical information the same way as the scientific community does. Therefore it might be useful, to implement standard procedures to confirm or discard a PHA classification by independent orbital calculations. This includes the willingness to share new data with exterior specialists as well as guidelines for communicating with the public media.

5. Conclusion

The impact hazard by Near-Earth Objects is strikingly different from most natural hazards in two ways: (a) the potential consequences of a major impact exceed any other known natural or man-made catastrophe (including nuclear wars) and (b) the probability of such an event is extremely low. Moreover, there is no single international procedure commonly agreed on, to deal with an event that never has taken place from the very beginning of human records. Asking the question of how much it is worth to save human civilization or even the entire species might be a first approach.

Literature and Web-references

- AANEAS Final report: <http://www1.tpgi.com.au/users/tps-seti/spacegd4.html>
- Alvarez, L.W., W.Alvarez, F.Azaro: Extraterrestrial cause of the Cretaceous-Tertiary extinction. *Science* **208** 1095-1108, 1992.
- Beijing Observatory (China), Xinglong Initiative: <http://vega.bac.pku.edu.cn/~zj/scap/scap.html>
- E. Bowell, K. Muinonen: Earth Crossing Asteroids and Comets: Groundbased Search Strategies in: T. Gehrels (Editor): "Hazards due to Comets and Asteroids", Univ. of Arizona Press, 1994.
- A.Carusi et.al.: Near Earth Objects: Present Search Programms; in: T. Gehrels (Editor): "Hazards due to Comets and Asteroids", Univ. of Arizona Press, 1994.
- Catalina Sky Survey: <http://www.lpl.arizona.edu/bss/>
- C.R. Chapman: The Asteroid/Comet Impact Hazard. (Currently as draft for the the Workshop on Prediction in the Earth Sciences; available on the net under <http://k2.space.swri.edu/clark/ncar.html>), April 1998
- Spaceguard Survey <http://ccf.arc.nasa.gov/sst/spaceguard/spaceguard.html>
- E. Tagliaferri, R. Spalding, C. Jackobs, S.P. Worden, A. Erlich: Detection of Meteoroid Impacts by Optical Sensors in Earth Orbit, in: T. Gehrels (Editor): "Hazards due to Comets and Asteroids", Univ. of Arizona Press, 1994.
- Klet Observatory (Czech Republic) NEO-project homepage: <http://www.ipex.cz/klet/metr.html>
- NEAT program homepage: <http://huev.jpl.nasa.gov/~spravdo/neat.html>
- Ondrejov NEO Project <http://sunkl.asu.cas.cz/~ppravec/>
- ODAS NEO Initiative: <http://pentium.pe.ba.dlr.de/odas/odas.htm>

ESA EXOBIOLOGY ACTIVITIES

Gerhard Kminek
ESA/ESTEC
Noordwijk, The Netherlands

Abstract

The *Microgravity and Manned Spaceflight Directorate* of the *European Space Agency* (ESA) has initiated two studies, one in 1996 and one in 1997, in order to assess the interest and the capabilities for a European effort in exobiology research. Both science teams were composed of senior scientists in the fields of microbiology, geology, cosmochemistry and related disciplines. The first report focused on reviewing the places in our solar system where life or pre-biotic evolution might have occurred sometime in the past or at present. The second report focused on an exobiology package for a Mars lander. The scientific objectives to achieve were to identify and characterize the oxidants, to find morphological and chemical signatures of extinct life, and to determine the chirality of organic compounds if present. In order to minimize ambiguities, an assembly of instruments was proposed to carry out the in-situ investigation. Forward contamination and sterilization issues shall be addressed from the very first stage of the program (Phase A). The whole exobiology system, including the sample acquisition, preparation and handling system has a mass of about 26 kg.

The science team report is the baseline for a nine month phase A study with industry and universities that will start mid- to third quarter 1998. In addition, exobiology will be a major cornerstone of the next microgravity program of ESA.

Introduction

The *European Space Agency* (ESA) has carried out studies and experiments related to exobiology in Low Earth Orbit (LEO) in the past. The *Exobiology and Radiation Assembly* (ERA) was part of the *European Retrievable Carrier* (EURECA) which was operational in 1992/93. ERA experiments were designed to study the impact of the LEO environment on cellular (e.g. spores), sub-cellular (e.g. membranes) and molecular (e.g. amino acids) systems that have been exposed to radiation and/or vacuum.

As a continuation of these experiments, ESA will put a *Space Exposure Biology Assembly* (SEBA) for a period of at least three years on the *International Space Station* (ISS), starting in 2002. SEBA is composed of two parts:

1. EXPOSE, which is a multiple sample container for radiation/vacuum exposure of small samples, including dark (protected from UV) reference samples. EXPOSE will be part of an EXPRESS pallet on the ISS truss.

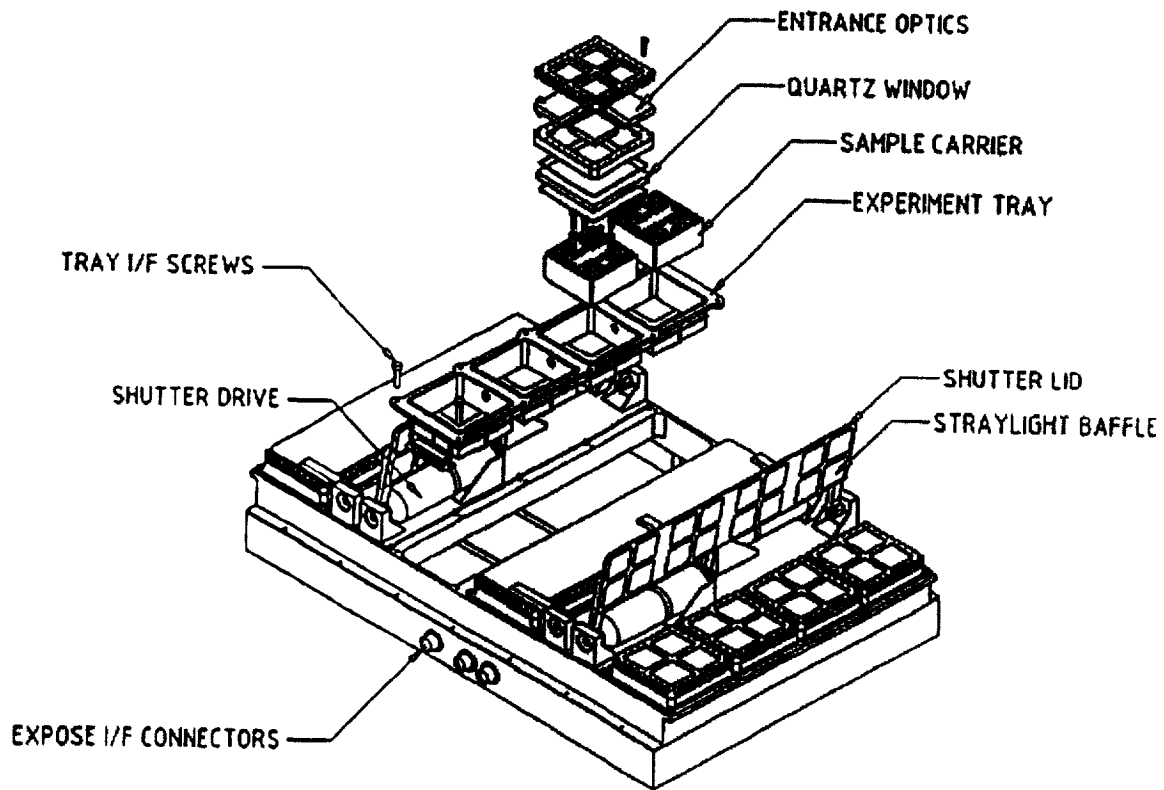

Fig. 1: Expose exploded view (Contract Report SEBA-KT-RP-007, ESA).

2. MATROSHKA, which is a commercially available RANDO® phantom that is used in radiation therapy, consisting of natural bones that are embedded in tissue-equivalent plastic to simulate human tissue and organs. Information on the biological impact of ionizing radiation on dedicated tissue and organ equivalents during EVA's is the main goal of the experiment. MATROSHKA will most likely be put on the exterior of one of the Russian ISS modules.

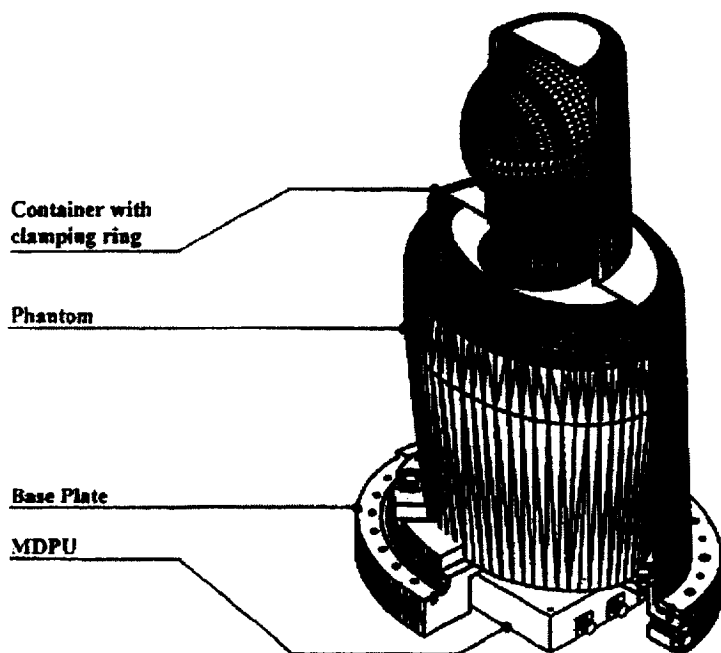

Fig. 2: Matrososhka configuration. MDPU is the Matrososhka Data Processing Unit (Contract Report SEBA-KT-RP-007, ESA).

After the announcement of possible biogenic activity in the Martian meteorite ALH 84001 in the summer of 1996 (D.S. McKay et al.; 1996), more attention has been given to the possibility of pre-biotic and biotic evolution outside the Earth. Whether the crucial step from pre-biotic chemical evolution to biochemistry really happened somewhere else in our solar system is of secondary importance in this respect.

In response to that, the *Microgravity and Manned Spaceflight Directorate* (MGS) of ESA initiated a science team study with the title: *'The Search for Life in the Solar System'*. The members of the science team were senior scientists in the disciplines of geochemistry, physics, biochemistry, cosmochemistry, molecular biology and some other related disciplines. The main objective of this study has been to identify environments within the solar system with appropriate conditions for pre-biotic evolution or the occurrence of biochemistry.

The recommendation of the report issued at the end of the study was that Mars had the most likely appropriate conditions in the past. Further, it will be frequently visited by robotic spacecraft in the near future. Therefore, Mars represents a reasonable target for further studies related to exobiology.

Following the advice from the science team, ESA initiated a second study with a different group of senior scientists to focus on environments, bio-signatures and instrumentation that would be required for an exobiology package that goes to Mars. The second science team finished their work and issued a report in June 1998 entitled: *'The Search for Life on Mars'*. Some of the results of this second report will be presented in this paper.

The science team split up in three groups according to their background and interest with different objectives.

TEAM	OBJECTIVE
Team 1	To define those sub-surface and near surface environments of Mars where evidence of past life might best be sought and to establish a shortlist of preferred landing sites for a future exobiology mission.
Team 2	To study specifically the chemical analysis aspect of an exobiology multi-user facility.
Team 3	To define a set of imaging and spectroscopic systems which will allow a search for evidence of extinct microbial life at all scales.

Fig. 3: Task teams.

The individual teams came up with the following conclusions:

Team 1: The major goal was to define environments with exobiological potential and, related to that, a set of landing sites. The presence of water and energy, either chemical or photosynthetic, in any period of time is the only requirement that was set forth for a specific location. Taking terrestrial analogies of environments where life can flourish, several potential environments have been identified:

- Lacustrine environments: these are areas where standing bodies of water existed for prolonged period of time. Remote sensing signatures for this kind of environment are channels entering craters, erosion features like terraces and a higher mineral concentration on the floor originating from evaporitic deposits.
- Sebkha's: these are areas where water was occasionally present but was dry most of the time. In Sebkha's, the evaporitic deposits are exposed to weathering effects during periods of dryness. Layering of deposits reflect the dry/wet cycle. Elevated mineral concentration, associated with these areas, provide a good remote sensing signature.

A special form of deposit related sometimes to Sebkha's is duricrust. Duricrust forms very hard layers of cement when mineral loaded water evaporates. Biological activity is usually found in these environments and the preservation of extinct life is known to be good. Nevertheless, because of its inherent hardness it is difficult to extract samples.

- Thermal spring deposits: related to volcanic activity and ground water. Biological activity is usually high but the preservation of bio-signatures is somewhat difficult. Racemization processes, e.g. for amino acids, is accelerated by the presence of water and higher temperatures so that only racemic mixtures are present at the end, which degrade to other compounds (e.g. amines, hydrocarbons and kerogen) (J.L.Bada, G.D.McDonald; 1995, A. Kanavaroti, R. Mancinelli; 1990).
- Permafrost: although viable biological life has been identified in permafrost layer on Earth (e.g. D.A. Gilichinsky et al.; 1993), limited accessibility of the Martian permafrost will restrict the search in these areas.

Although the team pointed out several landing areas, the consensus was to wait for the *Mars Global Surveyor* (MGS) data before selecting primary landing sites.

Team 2: In order to search for chemical indicators of life, a thorough characterization of the environment has to be carried out beforehand to avoid ambiguous conclusions. Chemical, mineralogical and petrologic investigations are therefore part of the exobiology package. At the same time, minerals can be used as a bio-signature as well because certain life-forms produce minerals during their metabolic process. These mineral usually have a different crystallography, morphology and/or isotope fractionation. Isotope fractionation of different elements is a major bio-marker on its own. Carbon fractionation (C^{13}/C^{12}) in favor of C^{12} is well established for photosynthetic processes and stable over geological timescales (M. Schidlowsky; 1988). Other fractionation processes include hydrogen/deuterium fractionation in methanogenic processes as well as nitrogen (N^{15}/N^{14}) and sulfur (S^{34}/S^{32}) fractionation. However, identifying sulfur fractionation is kind of tricky because it is very difficult to get rid of the sulfur as soon as it is injected in a GCMS system.

Although the non-biogenic fractionation processes on Mars are not well understood (B.M. Jakosky, J.H. Jones; 1997), the relative direction of the shift due to biological processes may give enough information to distinguish between inorganic and organic origin of the fractionation process.

Another useful bio-marker is molecular analysis. There are different kinds of organic and inorganic molecules that can be taken as indicators for biogenic processes. Related to that are different means to identify them. The most important inorganic molecules are water and oxidants such as hydrogen peroxide. The organic molecules can be classified in three groups:

- Volatile light organics like methane,
- Medium molecular weight organics like hydrocarbons and amino acids,
- Macromolecular components like kerogen and oligo's.

After identifying organic molecules, determination of their chirality can set limits for terrestrial contamination and distinguish between non-biogenic and biogenic origin.

In order to be able to identify all these bio-markers, a set of scientific instruments has been proposed by the team:

INSTRUMENT	PERFORMANCE	ANALYSIS
Alpha-Proton-X-Ray spectrometer (APXS)	1 wt %	Elemental analysis
Moessbauer Spectrometer	1 % of total Fe 1-50 % of bulk (G. Klingelhofer et al.; 1995)	Iron bearing mineral analysis, oxidation state, elemental analysis
RAMAN Spectrometer	Spectral range: 200-3500 wn Spectral resolution: 8 wn Spatial resolution: ~ 1 µm	Molecular analysis of organics and minerals
IR Spectrometer	Spectral range: 0.8-10 µm Spectral resolution: >100 (λ/Δλ) Spatial resolution: 200 µm	Molecular analysis of organics and minerals
Pyrolytic Gas Chromatograph & Mass Spectrometer	TBD	Analysis of inorganic/organic compounds, isotopic ratio and chirality determination.

Fig. 4: Payload for analytical analysis.

The APXS and the Moessbauer spectrometers provide an absolute abundance of elements and identify the mineralogical composition of iron-bearing minerals, as well as the oxidation state of the sample. Optical methods for sample selection, which will enhance the capabilities of mineral identification, will be discussed later. The complementary RAMAN- and the IR spectrometers are able to identify certain minerals and organic molecules (e.g. clays, hydrates, carbonates, C-H bonds of organic molecules, etc.). The wavelength of the IR spectrometer and the laser for the RAMAN has been chosen to cover compounds of relevance to exobiology. The PYR-GCMS unit is used for multiple measurements: for volatile compounds, the GC separates the different species according to their chemical reactivity and molecular weight and inject the particle beam for detailed mass analysis into the MS. The pyrolyser can be used to release non-volatile products to the GCMS unit. It can also be used for stepped combustion processes to differentiate between organics and carbonates in samples. Not included in the list is a dedicated instrument to measure the chirality of organic compounds. New developments in pharmacological instrumentation could help to find a small but capable instrument for that purpose (e.g. K. Bodenhofer et al.; 1987).

Team 3: Identification of macroscopic and microscopic bio-markers and characterization of the environment with optical methods requires a set of instruments with different resolution.

Apart from the identification of different mineralogies and sample selection, bio-markers of interest are: biofilm layers (biolamenaes) in the range of hundreds of microns to several millimeter, individual biofilms in the range of less than 100 microns, and microfossils in the range of 5 microns or less. In order to find and focus on the individual markers, a set of instruments was proposed:

INSTRUMENT	PERFORMANCE	EXOBIOLICAL OBJECTIVES	OTHER OBJECTIVES
Stereo Panoramic Camera	1000x1000 px 0.3 mrad/px 14 filters	Study rock types/gross bio-features	Landing site survey
Low Resolution Microscope	0.1 mm/px 5 filters	Examine samples prior to high res. and chemical studies	Examine samples prior to high res. and chemical studies
Optical Microscope	Res.: < 3 micron DoF: < 20 micron	Fossil identification	Mineral studies
Atomic Force Microscope (AFM)	Res.: 1nm FoV: 1x1 micron to 50x50 micron	High res. structural analysis	High res. structural analysis

Fig. 5: Payload for imaging.

The main concern for optical investigation of samples is the sample preparation. Cutting and polishing is usually required in order to get reasonable surfaces for microscopic investigations.

Implementation

With the whole instrument assembly, identification of all major bio-markers is possible. Most of the instruments complement each other in order to reduce ambiguities in interpreting the results.

System	Mass (kg)
Sub-surface drill system	6.5
Sample handling/distribution	4.0
Sample sectioning	0.3
Sample grinding	0.4
Low res. Microscope	0.2
Optical microscope	0.3
Atomic Force Microscope (AFM)	1.5
Microscopy transfer stage	1.0
APXS	0.5
Moessbauer spectrometer	0.5
RAMAN spectrometer	1.5
IR spectrometer	1.0
PYR-GCMS unit	5.5
Oxidant detector	0.4
(Laser ablation ICP mass spectrometer)	2.5
total	26.1

Fig. 6: Preliminary payload mass breakdown.

Sample preparation is crucial, in both the chemical and observational methods. Sample grinding (PYR-GCMS unit, chirality-unit), cutting and polishing (optical methods, APXS and Moessbauer spectrometers) will be required. Using small machinery that is rigid and stable enough to deliver the precision needed, as well as the material selected for that purpose, have to be evaluated. In earth-bound labs, diamond saws are used for cutting petrologic samples. The requirement to determine carbon at the ppm level may conflict with using diamond saws (the same is true for using carbide drill bits).

The consensus was to go for a drill system consisting of several drill stems adding up to an effective drill length of approximately 1.5 meters. Although it is not clear how deep the oxidants penetrate the Martian subsurface, measurements of the oxidant concentration can at least solve this problem.

The whole drill system with the instrument package shall be mounted on a lander. A rover-based system cannot give the required stability and space to accommodate all the instruments and mechanical systems. In this case, mobility of the system must be sacrificed for practicality.

Contamination

Forward contamination and sterilization must be considered from the very beginning of the program. Article IX of the *Outer Space Treaty* of 1967 states that one has to 'avoid harmful contamination' of outer space. NPG 8020.12 of the *NASA Planetary Protection Document* sets the requirements for all NASA robotic extraterrestrial spacecraft and NPG 5340.1 defines the basic procedure for assessing spacecraft contamination. Because the exobiology package is likely to fly on a NASA mission to Mars, all these regulations (and others) must be followed. In the USA, the regulations are implemented by NASA. They are accepted by COSPAR (*Committee on Space Research*) of the *International Council of Scientific Unions*. Reviews and periodic revisions are the result of newly obtained knowledge about planetary exploration and terrestrial ecosystems (J. Rummel*, private communication; SSB Biological Contamination of Mars, 1992).

Although the general believe of the *Space Science Board* (SSB) of the *National Research Council* (NRC) is that no terrestrial organism can survive on the surface of Mars today (SSB Mars Sample Return; 1997), forward contamination of carbon bearing compounds and microorganisms has to be minimized in order to achieve the required sensitivity for the scientific instruments. The first step is to select the SSB category of the mission without impacting the planet and the mission. Next is the twofold issue of carbon contamination and sterilization. Carbon contamination can be avoided by using materials that are carbon-free and/or have appropriate encapsulation. Sterilization is partly a design criteria and partly dependent on the bioload assessment. All spacecraft parts have to be accessible after integration for the appropriate sterilization procedure and a bioload assessment has to be done after that. More capable analytical techniques are available today that can detect single microorganisms (e.g. PCR (Polymerase Chain Reaction)). Including non-cultivable microorganism in the bioload assessment is of crucial importance since only a small fraction of all microorganisms is cultivable. The detection limit of the analytical instruments and the category of the mission profile determines the level of contamination. Naturally, there is the impact on the cost related to spacecraft design considerations and changes in order to comply with sterilization procedures.

Because the exobiology package is only part of a bigger system, considerations of other contaminants or common protocols are required

Conclusions

The science team report is the baseline for a nine month phase A study with industry and universities that will start mid- to third quarter 1998. In addition, ESA will propose a new microgravity program (following EMIR-2 and the MFC) that will include elements of the exobiology package. Discussions with ESA Member States started already (as of July 1998) and are assumed to last until mid 1999. If approved, the five-year program will start in 2000.

Acknowledgements

This work has been initiated, supported and directed by Dr. Paul Clancy, Manned Spaceflight and Microgravity Directorate, European Space Agency.

Members of the science team

Chairman: André Brack, Centre de Biophysique Moleculaire, CNRS, Orléans, France.
Beda Hofmann, Naturhistorisches Museum, Bern, Switzerland.
Gerda Horneck, Institute of Aerospace Medicine, DLR, Porz-Wahn, Germany.
Gero Kurat, Naturhistorisches Museum, Wien, Austria.
James Maxwell, Chemistry Dept. Bristol University, Bristol, England.
Gian G. Ori, Dipartimento di Scienze, Universita d'Annunzio, Pescara, Italy.
Colin Pillinger, Planetary Sciences Research Institute, Open University, Milton Keynes, England.
François Raulin, LISA, CNRS, Universités de Paris 7 et 12, Créteil, France.
Nicolas Thomas, MPI für Aeronomie, Lindau, Germany.
Frances Westall, Planetary Sciences Branch, NASA-Johnson Space Centre, Houston, USA.

Secretary: Brian Fitton, ESC, Noordwijk, Holland.

* J. Rummel, NASA-HQ, Planetary Protection Officer NASA.

References

- BADA, J.L., MCDONALD, G.D.: 'Amino Acid Racemization on Mars: Implications for the Preservation of Biomolecules from an Extinct Martian Biota', *Icarus* 114, 1995.
- BODENHOEFER, K. et al.: 'Chiral Discrimination using piezoelectric and optical gas sensors'; *Nature*, 387, 1997.
- GILICHINSKY, D.A. et al.: 'Cryoprotective Properties of Water in the Earth Cryolithosphere and its Role in Exobiology', *Origins of Life and Evolution of the Biosphere*, 23, 1993.
- JAKOSKY, B.M., JONES, J.H.: 'The History of Martian Volatiles', *Review of Geophysics*, 35,1 February 1997.
- KANAVAROTI, A., MANCINELLI, R.: 'Could Organic Matter Have Been Preserved on Mars for 3.5 Billion Years', *Icarus* 84, 1990.
- KLINGELHOEFER, G. et al.: 'Moessbauer spectroscopy in space', *Hyperfine Interact.*, 95, 1995.
- MCKAY, D.S. et al.: 'Search for Past Life on Mars: Possible Relic Biogenic Activity in Martian Meteorite ALH84001', *Science*, Vol. 273, 16 Aug. 1996.
- SCHIDLOWSKY, M.: 'A 3,800-million-year isotopic record of life from carbon in sedimentary rocks', *Nature*, Vol. 333, 26 May 1988.
- SSB 'Mars Sample Return, Issues and Recommendations', Task Group on Issues in Sample Return, Space Studies Board, Commission on Physical Sciences, Mathematics, and Applications, National research Council; National Academic Press, Washington D.C. 1997.
- SSB 'Biological Contamination of Mars, Issues and Recommendations', Task Group on Planetary Protection, Space Studies Board, Commission on Physical Sciences, Mathematics, and Applications, National research Council; National Academic Press, Washington D.C. 1992

A SPACE TESTBED FOR PHOTOVOLTAICS

Geoffrey A. Landis
Ohio Aerospace Institute
Brook Park, Ohio

and

Sheila G. Bailey
NASA Glenn Research Center
Cleveland, Ohio

Abstract

The Ohio Aerospace Institute and the NASA Lewis Research Center are designing and building a solar-cell calibration facility, the Photovoltaic Engineering Testbed (PET) to fly on the International Space Station to test advanced solar cell types in the space environment.

A wide variety of advanced solar cell types have become available in the last decade. Some of these solar cells offer more than twice the power per unit area of the silicon cells used for the space station power system. They also offer the possibilities of lower cost, lighter weight, and longer lifetime. The purpose of the PET facility is to reduce the cost of validating new technologies and bringing them to spaceflight readiness. The facility will be used for three primary functions: calibration, measurement, and qualification. It is scheduled to be launched in June of 2002.

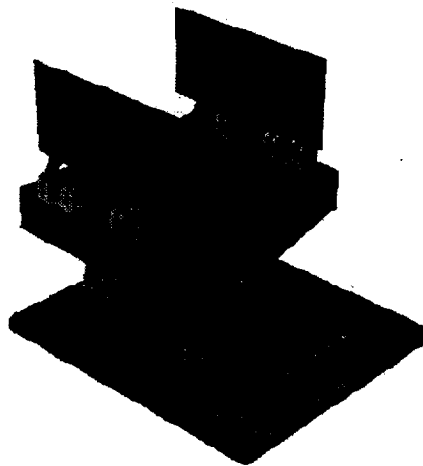

Figure 1: Conceptual Configuration of the Solar Cell Test Facility

This flight facility will fly improved solar cells in the space environment, which is a necessary precursor to predicting the performance, thus allowing an engineering baseline for the use of the cells in flight. The facility will be used for three primary functions: calibration, measurement, and qualification.

Calibration is used to create a space-measured reference cell which can be used to calibrate the performance of cells on the ground, allowing ground measurements to be

referenced to an actual space-flown standard of the same type.

Measurement consists of measurements of the performance of cells in space, in particular measuring values of parameters which are sensitive to the space solar spectrum or environment, such as the temperature coefficient.

Qualification consists of verifying that the performance of an interconnected solar-cell coupon does not degrade over time in the space environment.

Space solar cells cannot be measured accurately using the sunlight at the Earth's surface, since absorption in the atmosphere means that the terrestrial solar spectrum is ultraviolet and parts of the infrared spectrum. Currently, measurements of solar cell efficiency are made using artificial light, or "simulated AM0" sunlight. The most commonly used AM0 simulation standard is the X-25 xenon-arc solar simulator. However, while the spectrum of a simulator roughly approximates that of space sunlight, the actual shape of the spectrum is different. The xenon arc has a number of distinct bright emission lines, which show up as spikes in the spectrum. It also has a somewhat different shape from the actual solar spectrum.

Use of this simulated AM0 sunlight for solar cell measurement requires a calibrated primary reference standard identical in type to the cell measured. NASA Lewis currently produces standard cells by use of an airplane which makes measurement to an Air Mass of approximately 0.25 (that is, above 75% of the Earth's atmosphere). This is done at an altitude of 15,000 meters. An alternate method is to use a balloon flight. However, even a high-altitude balloon does not reach true air mass zero. An actual space-flown standard is required to calibrate the airplane- and balloon-flown standards.

For conventional cell types, such as the Si solar cells being flown on Space Station, the calibration of the standards is well known, due to a long history of space flight use. For new solar cell types, however, there is no flight history. The highest efficiency of the new cell types increase their conversion efficiency by use of two, or even three, active layers, each one sensitive to a different spectral range of light. This makes the performance of the new solar cell types extremely sensitive to the spectrum, and means that they cannot be accurately measured in simulated sunlight, without a space-calibrated cell for reference in each of the spectral ranges of interest.

Since solar cells on-orbit typically operate at temperatures between 45 and 100°C, characteristic of sun-facing surfaces in Earth orbit, the standard measurement at 25°C requires a temperature coefficient measurement to predict performance in space. However, temperature coefficients are sensitive to the exact spectrum of light used. A feature of this in-space measurement facility will be the measurement of the effect of temperature on cell performance under space conditions. True temperature coefficients are nearly impossible to measure with simulated sunlight, since the variation of current of a solar cell with temperature is extremely sensitive to the detailed shape of the spectrum. Emission lines in the xenon-simulated solar spectrum result in Isc temperature coefficients that can be incorrect by a factor of five; and in some cases can even have the incorrect sign. This is particularly true for high-efficiency tandem solar cells, since the light absorption of two or more active layers are both dependent on both spectrum and temperature. The proposed facility will allow accurate prediction of the performance of the cells under actual in-space operating conditions.

Finally, the qualification function of the testbed will be used to verify that the performance of an interconnected coupon does not degrade in the space environment, which is the final critical step leading to flight qualification and acceptance of a new technology. By doing flight exposure on the space station testbed, the qualified samples can be returned for examination after the test. This will give us the ability to diagnose failure mechanisms (if any), allowing a technology to be fine-tuned as required to pass

performance specifications.

The project addresses the key barrier to the adoption of new technology: reduction of risk. Workshops at the tenth and eleventh Space Photovoltaic Research and Technology Conference, attended by 40 representative of universities, government contractors and DOD, DOE, and NASA addressed the barriers to adoption of new technology for solar arrays. They concluded "that a National effort to insure regular flight opportunities [to test new solar cell technology] should be made," and that "space flight tests will be needed in the future as far as can be imagined, because of the inadequacy of simulating the complex combined environment of space." Before a manufacturing project is initiated to bring a new cell technology to commercialization, the "cell must have passed space qualification, flight demonstrations, reliability and good performance at end of life" [that is, after space exposure]. To be considered by mission planners, the technology must be demonstrated to "be as risk-free as presently used cells." This requires space calibration and measurement of the cell.

By performing calibration, measurement, and qualification, advanced technologies with considerably higher performance will be transitioned into engineering readiness for flight.

The calibration facility will be configured to fit the space-station as a self-contained payload with standardized interface to the station. By using this standardized flight interface, we allow maximum flexibility in scheduling, and minimize the difficulty of interfacing and possible conflicts with the station operations. The facility will be designed to be reusable with minimum refurbishment.

Engineering

The facility is comprised of four subsystems:

- (1) exchangeable mounting plates for samples
- (2) mounting substrate (including tracking subsystem)
- (3) electronics and control subsystem
- (4) attachment and interconnection hardware

Samples are mounted on 40 cm square sample-holder plates. The plates will be made from aluminum/composite honeycomb sheet. The facility is configured to allow four of these sample-holders to be used simultaneously. The sample-holder plates are removed to return samples to Earth. The number of solar cells which can be calibrated per sample holder plate will depend on the size of the cell. For standard 4 cm square test cells, 40 cells can be accommodated on each plate.

The mounting substrate is the unit on which the sample holders are mounted. This is permanently attached external attach point. The substrate incorporates a low slew-rate tracking system to zero the beta angle so that the local sun angle is normal to the surface.

The facility will consist of a mounting surface configured to accept removable sample pallets, each of which contains solar cell samples to be measured, a thermocouple to measure temperature, and a cooling module to maintain the standard test temperature of 25°C and to provide a range of temperatures for thermal effects testing. An Eppley absolute cavity radiometer monitors the incident flux for reference purposes. Fine tracking of solar position will be done using an off the shelf sun-tracking gimbal. The facility will test a solar cell in a period of under one minute. The data is logged in electronic form on an on-board memory, which can be downloaded to the data system as convenient.



A TELEDESIC SPACE INFRASTRUCTURE OVERVIEW

Mark G. Matossian
Teledesic Corporation
Kirkland, Washington

Abstract

The Teledesic Network uses a constellation of 288 interlinked low-Earth orbit satellites to provide global access to a broad range of voice, data and video communication capabilities. Through its global partnerships, the Network provides switched digital connections between users of the Network and, via gateways, to users on other networks. A variety of terminals accommodate "on-demand" channel rates from 16 Kbps up to 2.048 Mbps ("E1"), and for special applications up to 1.24416 Gbps ("OC-24"). This allows a flexible, efficient match between system resources and the requirements of users' diverse applications.

The constellation provides 24 hour seamless coverage to +/-72 degrees latitude at near-circular orbits inclined at approximately 84.7 degrees and 1375 km. The 24 spacecraft in each of the unphased 12 orbital planes have ascending nodes separated by approximately 15 degrees. The Teledesic spacecraft are specifically designed to take advantage of the economies that result from high volume production and launch. All spacecraft are identical and use technologies and components that allow a high degree of

automation for both production and test. To minimize launch cost and the deployment interval, the spacecraft are designed to be stacked so that multiple spacecraft can be launched on a single vehicle. Individual spacecraft, the constellation as a whole, and the constellation control centers are designed to operate with a high degree of autonomy.

1.0 Introduction

The Teledesic constellation design supports the network requirements for quality, capacity and integrity. To provide high-quality, high-speed wireless channels at the intended peak user density levels requires substantial bandwidth. The only feasible frequency band internationally allocated to Fixed Satellite Service that meets Teledesic's requirements is the Ka band. High rain attenuation, terrain blocking, and other terrestrial systems in this band make it difficult for earth terminals to communicate reliably with a satellite at a low elevation angle. The Teledesic constellation uses a high elevation mask angle of 40 degrees to mitigate these problems. A low orbit altitude is used to meet the requirements for low end-to-end delay and reliable communication links that use low power and small

antennas. The combination of low altitude and high elevation mask angle results in a small coverage area per satellite and a large number of satellites for global coverage. A high degree of coverage redundancy and the use of on-orbit spares support the network reliability requirements.

Through a broad, cooperative effort, Teledesic will bring affordable access to fiber-like telecommunications services to all parts of the world that would not be economical to serve through terrestrial means.

Today, advanced telecommunications infrastructure is limited to the developed urban areas of the world. This leaves most of the world's population without access to even basic communications services. Even those areas with basic voice service get access through 100-year-old technology – analog, copper networks – that for the overwhelming part will never be upgraded to support digital, broadband services.

Teledesic is building a global, broadband "Internet-in-the-Sky." Using a constellation of several hundred low-Earth-orbit satellites, Teledesic will create the world's first network to provide affordable, worldwide, "fiber-like" access to telecommunications services such as broadband Internet access, videoconferencing, high-quality voice and other digital data needs. On Day One of service, Teledesic will enable broadband telecommunications access for businesses, schools and individuals everywhere on the planet.

Teledesic was founded in 1990 and is headquartered in Kirkland, Washington, a suburb of Seattle. Teledesic represents the vision of its chairman, telecommunications pioneer Craig McCaw, and is backed by Microsoft Chairman Bill Gates and The Boeing Company. Boeing, the world's largest aerospace company, will lead the international industrial team to manufacture and launch the satellite constellation, which will be in service in 2002.

Teledesic has received support from the developed and developing world alike, resulting in both international and domestic satellite service designations for the frequencies necessary to accommodate the Teledesic Network. In March 1997, the U.S. Federal Communications Commission licensed Teledesic to build, launch, and operate the Teledesic Network.

2.0 The Teledesic Network

Teledesic does not intend to market services directly to end-users. Rather, it will provide an open network for the delivery of such services by others. The Teledesic Network will enable service providers in host countries to extend their networks, both in terms of geographic scope and in the kinds of services they can offer. Ground-based gateways will enable service providers to offer seamless links to other wireline and wireless networks, such as the Internet.

The Teledesic Network will consist of 288 operational satellites divided into 12 planes, each with 24 satellites. To make efficient use of the radio spectrum, frequencies are allocated dynamically and reused many times

within each satellite footprint. Within any circular area of 100 km radius, the Teledesic Network can support over 500 megabits per second (Mbps) of data to and from user terminals. The Teledesic Network supports bandwidth-on-demand, allowing a user to request and release capacity as needed. This enables users to pay only for the capacity they actually use, and for the Network to support a much higher number of users.

Teledesic will operate in a portion of the high-frequency Ka-band (28.6 - 29.1 GHz uplink and 18.8 - 19.3 GHz downlink). The Teledesic Network's low orbit eliminates the long signal delay experienced in communications through traditional geostationary satellites and enables the use of small, low-power terminals and antennas, about the size of direct broadcast satellite (DBS) dishes.

The Teledesic Network is designed to support millions of simultaneous users. Most users will have two-way connections that provide up to 64 Mbps on the downlink and up to 2 Mbps on the uplink. Broadband terminals will offer 64 Mbps of two-way capacity. This represents access speeds up to 2,000 times faster than today's standard analog modems. For example, transmitting a set of X-rays may take four hours over one of today's standard modems. The same images can be sent over the Teledesic Network in seven seconds.

Design, production and deployment of the Teledesic Network will cost \$9 billion. End-user rates will be set by service providers, but Teledesic expects rates to be comparable to those

of future urban wireline services for broadband access.

3.0 Seamless Compatibility with Terrestrial Networks

Without knowing for certain all the applications and data protocols a broadband network will be called upon to accommodate in the 21st Century, it is reasonable to assume that those applications will be developed in the advanced urban areas of the developed world – where fiber-optics sets the standard. Satellite systems offer the capability to provide location-insensitive, switched, broadband access, extending the reach of networks and applications to anywhere on Earth. But to ensure seamless compatibility with those networks, a satellite system should be designed with the same essential characteristics as fiber networks – broadband channels, low error rates and low delays.

Satellite systems are of two general types: geostationary-Earth-orbit (GEO) and non-geostationary, primarily low-Earth-orbit (LEO). Geostationary satellites orbit at an altitude of 36,000 kilometers (km) above the Equator – the only orbit that allows the satellite to maintain a fixed position in relation to Earth. At this height, communications through a GEO entail a minimum round-trip transmission latency – end-to-end delay – of at least one-half second. This means that GEOs over provide fiber-like delays.

This GEO latency is the source of the annoying delay in many intercontinental phone calls, impeding

understanding and distorting the personal nuances of speech. What can be an inconvenience on voice transmissions, however, can be untenable for real-time applications such as videoconferencing as well as many standard data protocols – even for the protocols underlying the Internet.

One of the fundamental principles of the Internet is the notion of all applications moving onto a common network platform – an open network based on common standards and protocols. The idea of stand-alone, proprietary networks, or application-specific networks, is fast disappearing. All applications will move over the same networks, using the same protocols. In these packet-switched networks – where voice, video, and data are all just packets of digitized bits – it is not practical to separate out applications that can tolerate delay from those that cannot. As a result, the network should be designed for the most demanding application. The Teledesic Network is designed to provide end-to-end Quality-of-Service that enables global enterprise networking, meeting the demands of the Internet of the future.

4.0 Distributed vs. Centralized Architecture

Just as networks on the ground have evolved from centralized systems built around a single mainframe computer to distributed networks of interconnected PCs, space-based satellite

networks are evolving from centralized networks relying on a single geostationary satellite to distributed networks of interconnected low-Earth-orbit satellites. In geostationary systems, any single satellite loss or failure is catastrophic to the system. To reduce this contingency to acceptable levels, reliability must be engineered far along toward the point of diminishing returns where further gains in reliability are achieved only at a very high cost.

With a distributed network, like the Teledesic Network, reliability can be built into the network rather than the individual unit, reducing the complexity and cost of the individual satellites and enabling more streamlined, automated manufacturing processes and associated design enhancements. In its distributed architecture, dynamic routing, and robust scalability, the Teledesic Network emulates the most famous distributed network, the Internet, while adding the benefits of real-time capability and location-insensitive access.

5.0 Low-Earth-Orbit Satellite Systems

The evolution from geostationary to low-Earth-orbit (LEO) satellites has resulted in a number of proposed global satellite systems, which can be grouped into three distinct types. These LEO systems can best be distinguished by reference to their terrestrial counterparts: paging, cellular, and fiber.

The Big LEOs, for example, provide premium-priced, narrowband mobile voice service, whereas Teledesic provides primarily fixed, broadband connections at costs comparable to urban wireline service. Just as cellular and fiber are generally not considered to be competitive, the only thing Teledesic really has in common with the Big LEOs is the use of low-Earth-orbit satellites.

6.0 Elevation Angle

The Teledesic Network is designed so that from anywhere on Earth, a Teledesic satellite can always be viewed nearly directly overhead. This

angle. Teledesic's 40° elevation angle is essential to meeting the company's goals for high quality-of-service, with availability comparable to terrestrial networks. It also reduces the user terminal size and cost and improves the ease of coordinating the use of radio frequencies with other systems and services.

7.0 The Market for Teledesic

The convergence of computing and communications is causing all things one associates with a high standard of living – from education and health care to economic development and public services – to become dependent on an ever-increasing flow of information. In

<i>Example</i>	Orbcomm, Vita	Iridium, Globalstar, ICO	Teledesic
<i>Terrestrial Counterpart</i>	Paging	Cellular	Fiber
<i>Frequency</i>	<1 GHz	1-3 GHz	20/30 GHz

is ensured by having an elevation angle of 40 degrees or higher at all times in all locations.

Teledesic's 40° elevation angle enables users to place terminals on most offices, schools, and homes with an unobstructed view of the sky in all directions. A lower elevation angle dramatically increases the likelihood of obstruction by surrounding buildings, trees, or terrain, preventing service. In many areas, a low elevation angle can make any service impractical or simply impossible.

Additionally, signals at high frequencies can also be blocked by rain, especially when sent at a lower elevation

highly urbanized areas, this demand for information is being satisfied by the high-bandwidth and high-quality connections of fiber optics. Increasingly, institutions and individuals are utilizing broadband connections for Internet access, computer networking, aggregation and trunking of voice lines, and telecommuting. But step out of the cities, and these fiber-like telecommunications services become prohibitively expensive or are simply unavailable at any price.

The Teledesic Network will seamlessly extend the existing terrestrial, fiber-based infrastructure to provide

advanced information services anywhere on Earth. Customers will range from the information workers unwilling to be confined in increasingly congested cities, to countries backhauling aggregated voice lines from remote cellular sites, to multinational corporations connecting branch offices throughout the world into their existing global enterprise networks. Whenever and wherever institutions and individuals want access to the fiber-like telecommunications services currently available only in the most highly developed urban areas, the Teledesic Network can provide seamless connectivity.

And because Teledesic satellites move in relation to the Earth, Teledesic provides the same quality and capacity of service to all parts of the globe. In this sense, Teledesic's Internet-in-the-Sky is an inherently egalitarian technology. On Day One of service, Teledesic will help transform the economics of telecommunications to enable universal access to the Internet and the information age.

CONCURRENT DESIGN USED IN THE DESIGN OF SPACE INSTRUMENTS

Knut I. Oxnevad
Jet Propulsion Laboratory
California Institute of Technology
Pasadena, California

ABSTRACT

At the Project Design Center at the Jet Propulsion Laboratory, a concurrent design environment is under development for supporting development and analyses of space instruments in the early, conceptual design phases. This environment is being utilized by a Team I, a multidisciplinary group of experts. Team I is providing study and proposal support. To provide the required support, the Team I concurrent design environment features effectively interconnected high-end optics, CAD, and thermal design and analysis tools. Innovative approaches for linking tools, and for transferring files between applications have been implemented. These approaches together with effective sharing of geometry between the optics, CAD, and thermal tools are already showing significant timesavings.

Keywords: Concurrent Engineering, Graphical Programming, Multidisciplinary Teams, Conceptual Design, Space Instruments, Total Systems Approach, Systems Engineering, Concurrent Design.

1. INTRODUCTION

At the Jet Propulsion Laboratory (JPL), large resources are put into efforts aiming at improving and changing the organization to effectively deal with developing smaller missions in the hundred million, rather than in the billion dollar range. A large number of these missions are won based on competitive proposals in response to Announcement of Opportunities (AO's) from NASA headquarters. Writing and developing proposals is, therefore, becoming increasingly important for JPL.

To support the high number of proposals, this year about 50, a proposal support infrastructure has been developed. The Project Design Center (PDC) which has been developed over some 3 years forms the core of this support. The initial aim^{1,2} of the PDC was to support various projects and proposals with early conceptual mission design analysis capabilities. These conceptual mission designs are developed in a couple of weeks by a multidisciplinary team of specialists that work concurrently, in the same room, together with their customers on a set of computers (stations) and tools that are linked. The team, called Team X, utilizes Macintosh computers, Excel spreadsheets, and publish and subscribe for linking these spreadsheets together. This provides a very powerful environment for conceptual mission design studies.

In late 1996, it was decided that there was also a need for a team that could provide early conceptual design analysis support for instrument development and instrument proposal work. This led to the development and implementation of Team I. Team I builds on the same general principles as Team X, but different customer requirements led to a different implementation. Typically, an instrument proposal requires a higher degree of detail in both the optical, radiometric, and thermal analyses. Team I is, therefore, utilizing what is considered high end tools, rather than spreadsheets for their development and analysis work.

The initial version of Team I was set up to primarily support optical instrument work. The Team I set of tools, consequently, includes tools such as Code V, ZeMax, TracePro, Mechanical Desk Top (MDT), and

RadCAD/SINDA.³ Most of the Team I tools are running on PC NT platforms. The plan is to modify the Team I composition and tool set to also support other types of instruments.

Integrating these high end tools in a user friendly way, and making the passing of data between them effective and happen in near real time required the Team I development group, headed by the author, to employ some innovative approaches⁴. The development of executives, utilizing a graphical programming language, represents one such approach. This language makes code generation as well as code modification relatively easy. The latter is especially important in an environment requiring rapid adaptation to new customer needs.

Team I includes experts from the areas of optical analysis and design, mechanical and CAD design, thermal analysis, costing, radiometry, and electronics analysis and design. Each of these experts man a computer with the appropriate tools. During the development phase these experts worked very closely with the development group. These experts are also playing an active role together with Team I customers in the continuous development and improvements taking place as more operational experience is being gained.

This paper starts with a description of the Team I environment and ends with a discussion about some of the approaches utilized in the Team I environment that are showing great potential for time savings. The Team I environment is described in section 2, its stations in section 2.1 and its process in section 2.2. Team I unique approaches for saving time are discussed in section 3. Some of these approaches are the computerizing of preliminary calculations, section 3.1; the automating of data transfers between tools, section 3.2; and the sharing of common geometry between applications, section 3.3. A glossary is provided in section 6.

2. THE TEAM I ENVIRONMENT

2.1 The Stations

In its current configuration, Team I includes a mechanical/CAD station, an optics station, a radiometry station, a thermal station, a cost station, a system station, a documentation station, and an electronics station.

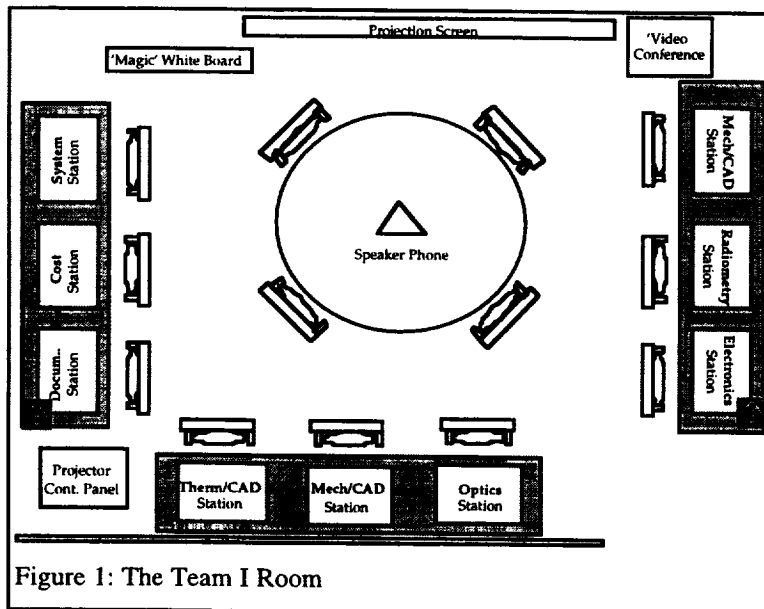

Figure 1: The Team I Room

Figure 1: The Team I Room, on this page.

The current Team I configuration is primarily set up to support the design and analysis of optical instruments. However, the Team I environment was made to be flexible and be able to change with changing customer needs. Changes may effect both the station and tools mix. The electronics and documentation stations are still under development, and they will, therefore, not be discussed any further. The visualization station, also called the orbital analysis station, is for now incorporated into the system station and will briefly be discussed under that station. To improve group interactions, any station's display can be shown on the large projection screen in front of the Team I room, shown in

At the **optics station**, an optical designer and analyst uses variables such as number of wavelengths, aperture diameter, F#, field of view (degrees), temperature, mirror/lens surface types, and type of mirror material for designing the right optics configuration. The tools Code V and ZeMax are used for this part of the design and

analysis work. The geometric representation of the surfaces of the selected optics configuration, together with the geometric representation of the resulting rays, are provided as an IGES file. Additionally, the optics configurations itself can be ported to TracePro (ACIS based), also on the optics station, and turned into ACIS based solids and provided as SAT files. These SAT files can be exchanged between any ACIS based programs. Mechanical Desktop (MDT) is one such program. Cost and mass estimates of the developed optics configuration can also be provided. The ACIS engine is developed by Spatial Technology.

At the **radiometry station**, variables such as required temperature, quantum efficiency, dark current level and readout noise of the detectors, #bits/pixel, aperture diameter, F#, spectral resolution, target scene reflectivity, altitude, number of bands, and observed wavelengths are used for ensuring that minimum signal to noise (S/N) ratios are achieved, and for calculating noise equivalent temperature (NEAT) curves. The tools used for these calculations was developed by the radiometry analyst in Excel spreadsheets.

The mechanical designer sits at the **mechanical/CAD station**. His/her job is to design support structures (holders for lenses, mirrors, and detectors) and enclosures around the optics configuration provided as output from the optics station. The geometry of these set ups is provided in IGES and SAT formats. MDT, which is also built on the ACIS engine is currently being used as the Team I CAD tool. The station also provides preliminary mass, volume, and area estimates of the developed instrument design. The mechanical/CAD work can be time-consuming, and it is, therefore, mostly done before or after a concurrent session. More about this in section 2.2, The Process.

At the **thermal station**, a combination of RadCAD and SINDA tools are used. RadCAD uses the geometry developed on the mechanical/CAD station together with orbital parameters, for calculating orbital heating rates, and for producing radiation interchange factors. SINDA, a thermal analysis program, utilizes these results for calculating detector and optics temperatures for the given orbital environments. This information is then used for discussions about radiator placing, and about whether active or passive cooling is required.

The **cost station** is manned by a cost expert that will perform either grassroots costing (costing by analogy) or parametric costing. The parametric cost models take into account factors such as mass, type of technology, development time, and complexity of instrument part. Output from the cost station is fed into the system station.

At the **system station**, the high level mission parameters (inputs) are defined at the beginning of the session. The main output variables are also sent to and displayed on this station. Some of the high level mission parameters are type of mission; type of orbit; the classical orbital parameters, semi major axis, orbital inclination (calculated for Sun synchronous orbits), right ascension of ascending node, argument of periapsis, true anomaly, and observation time and date; orbital time (calculated), orbital velocity calculated (rad/s, and km/s); orbiting body (Earth, Mars, etc.); surface temperature, reflectivity of orbiting body; wavelengths to be observed at; and number of bands. The main output variables are instrument mass and cost, and the power required by the instrument. Preliminary estimations of instrument data rates and communication downlink data rates will also be calculated and displayed on the system station. The system station was put in place primarily to ensure that all applications would be using the same high level system parameters at all points in the design cycle. This is achieved by the system station making these high level parameters available to the various Team I applications in a format that they can read. In the same way, data from the various applications are extracted from their output files and displayed on the system station. This work is under development. LabVIEW has been used for developing file data extraction routines, file building routines, and routines for exchanging data between the team I applications and the system station. Collectively these routines or programs are called executives. The Team I satellite orbital analysis and display software (SOAP) is also located on the system station, so is the electronic white board used in some Team I sessions.

2.2 The Process

The Team I process is under development, and the process that is being described here is what the Team I development group is working towards. The process, which is shown in Figure 2: The Design Process, starts with Team I sending a potential customer a list of input parameters required by the team prior to a Team I session. The list can be accessed and filled in from the Team I Home-Page. About a week after the list has been sent to the customer, Team I and the customer meet to discuss the input list and plan the Team I sessions. At this meeting, the customer will also be briefed on the workings of Team I. Based on the input from this meeting, the Team I members and developers will prepare the session. These preparations will vary in volume and complexity depending on the type of support the customer requires, complexity of instrument, and inheritance from other instruments.

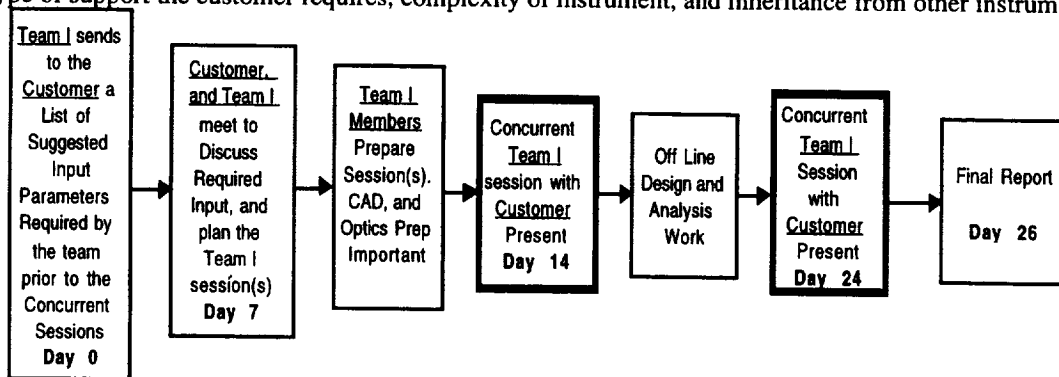

Figure 2: The Design Process

The radiometry expert may have to modify his models to make them work with the specified number of bands, the spectrum being analyzed, and the number of detectors required. The optics expert will have to do preliminary design and analysis on an optics (lenses, or mirrors) configuration that meets customer requirements on orbital altitude, ground resolution (instantaneous field of view: IFOV), swath width, and aperture size. This work easily takes a week. The optics expert will use Code V or ZeMax for this work. At the mechanical/CAD station, a preliminary model of the instrument will be put together. This will be used for visualizing the design and helping the Team I members better understand issues, such as orientation towards the sun, direction of the orbital velocity vector, and direction to the orbiting object. On the system station, the main input parameters will be set up, and calculations of variables such as inclination, orbital time, and orbital velocity will be performed. Possible modifications to the system front page will also be performed to meet special requests from the customer. The orbital parameters from the system station will be used for setting up SOAP for visualizing and analyzing the selected orbit. The thermal expert will also utilize these parameters for setting up RadCAD.

The aim of all of these preparations, is to have the tools prepared to a point where, it becomes possible to perform changes and trades, in a concurrent fashion.

On about day 14, the customer and the Team I members meet to conduct a concurrent design session. The main flows and interactions between the Team I stations are illustrated in Figure 3: Interconnected, High-End Analysis, and Design Tools. These sessions are lead by the Team I leader.

Encircled numbers (1...5) show the main steps in the design process. These are discussed below. Dotted lines indicate that electronic transfer of data between applications on the shown stations is under development or under consideration for development. Complete lines indicate that electronic data currently can be transferred and used by applications on the station at the end of the arrow. Connections being regarded as important, especially from a timesavings perspective, are marked with thick complete lines. These connections are discussed in more detail in section 3.3, Sharing Common Geometry.

The Team I session would start (1) with the Team, together, furnishing the high level mission parameters for the system station. At this point the system station display would be shown on the large projection screen. Ref. Figure 1: The Team I Room. Having the team do this together, helps getting it on the same page from the very beginning of the session. The system station serves both as a placeholder, as well as a point of distribution for these common high level parameters. Preliminary calculations of orbital time, velocity, inclination are also performed. Next, for visualizing the mission, the six orbital parameters are fed automatically through a routine into a SOAP .orb file. This file is then automatically opened and displayed on the system station and on the large projection screen. As the dotted arrows in the figure above indicate, there also are plans for electronically transferring high level parameters to other applications. After the high level mission parameters are established, typically work starts in parallel, and interactively, on the optics station, and on the radiometry station (2). Aperture diameter, detector placing, and focal length, are defined on the radiometry station, and utilized by the optics station, using Code V, or ZeMax, for setting up, and analyzing initial, and prepared optics configurations. After some back and forth between these stations, a recommended optics configuration should emerge. The geometric representation of this configuration is transferred to TracePro and turned into ACIS solids. These are saved in a SAT file format. In parallel, the same geometry plus the resulting rays are saved as an IGES file. The two files are read into MDT (3), on the mechanical/CAD station. Next, the geometries in these two files are aligned, ensuring that the surfaces from the IGES file, exactly match the corresponding surfaces of the TracePro developed solids lenses, mirrors, and detectors. This process also perfectly aligns the rays. At the mech/CAD station, support structure, an enclosure, radiators, and electronics are added. Some of these parts may have

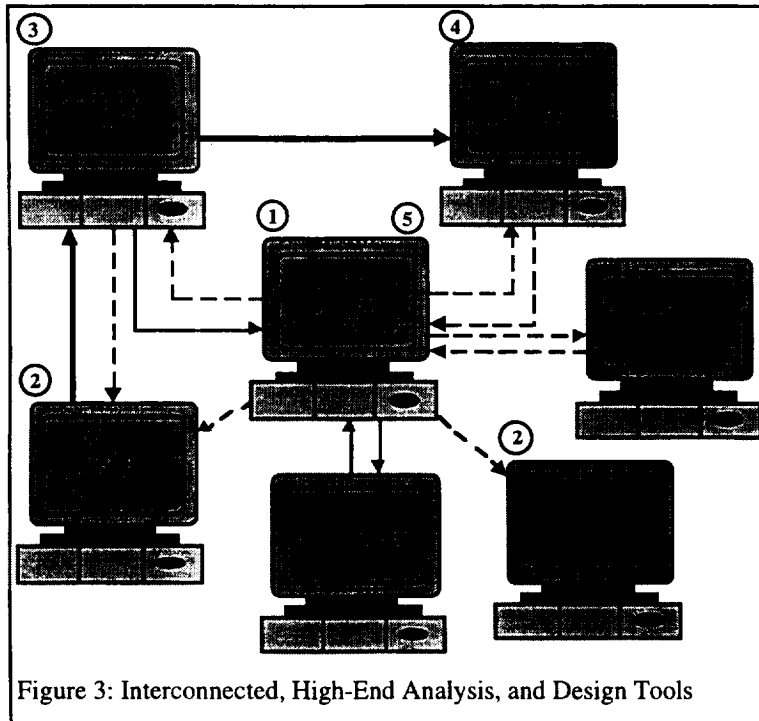

Figure 3: Interconnected, High-End Analysis, and Design Tools

been prepared before the session or during the time the time of the optics analysis. As part of the Team I development effort, we are looking into effective ways of parameterizing key dimensions of the support structures, making it possible to modify and use them for a variety of mirror and lens shapes, and sizes. The final CAD drawing will in most cases be finished after the concurrent session. However, after an initial geometry, including lenses, and support structures has been developed, it will be used directly by RadCAD (4) for calculating orbital heating rates and for producing radiation conductors. For this purpose, a very detailed geometric representation of the instrument is not required. Prior to getting the geometry from the mech/CAD station, preliminary orbital heating rates can, therefore, be calculated based on the simple geometry of a box dimensioned as the final instrument and the orbital parameters provided from the system station. From the RadCAD analysis, a file containing form factors and radiation conductors is imported to SINDA for calculating detector and optics temperatures. The MDT developed solids geometry (lenses, support structures, and detectors) may be saved as a SAT file, and transferred back to TracePro for stray light analyses.

After all these analyses have been performed, and there is agreement that the resulting design meets the set design criteria, mass and cost will be calculated and displayed on the system station (5) together with other main output variables such as data rate and power. Datarate calculations will initially be performed on the system station. Mass will be calculated in two ways, one based on volume and densities as defined in MDT and Code V (lenses and mirrors), and one based on mass relationships derived from expert knowledge from the Team I members. For mass

estimates provided by MDT, a routine has been developed for automatically extracting this information from the MDT mass file, and displaying it on the system station. The instrument costing process is still under development.

Most likely, issues will arise during this first session that may require more detailed analysis that should be done off line. A likely scenario is, therefore, that after the first concurrent session the team and the customer take a break for about 10 days. This should give the customer time to consider the initial results, and the team members time to do required off-line design and analysis work. Any changes coming from the customer should be conveyed to the team members in good time for them to prepare for the second concurrent session at day 24.

The design and analysis process for this session will be similar to that of the first session, with the exception that a report has to be generated at the end of it. Currently, this report is generated jointly by the Team I members during the session. The final report will be delivered to the customer a couple of days later. If no design has been reached that satisfies the customer requirements or if the instrument is too complex for just two concurrent sessions, the report will be postponed to the last concurrent session between the customer and Team I.

3. REDUCING DEVELOPMENT AND ANALYSIS TIME

3.1 Computerizing Preliminary Calculations

After having gone through some concurrent sessions, utilizing parts of the Team I process, it seems that time can be saved by reducing the number of reoccurring manual calculations done on pieces of paper at the beginning of these sessions. Typically, these calculations range from orbital time, to estimates of aperture diameter. It was assumed that time could be saved by making these calculations and their results electronically available.

The Team I development group, therefore, is looking into using G-code developed by National Instruments, for developing small programs, above called executives, that will perform these calculations. These programs or virtual instruments (VI) will be linked directly to the high level parameters on the system station, also developed in G-code. This will make it possible to perform effective and numerous trade-off analyses based on those parameters. Both input and output variable values from those trade-off analyses will be stored in a file for later retrieval and analysis. This file is set up on the system station and termed the history file. The calculations to be performed in this way are primarily mission related and high level calculations, not performed on any of the other stations. So far, VI's for calculating orbital time, velocity, inclination of Sun synchronous orbits, aperture diameter, F#, have been implemented in the Team I environment. More VI's will be added. The benefit of using G-code is that it is simple to learn, easy to develop in, and easy to modify. These features enables rapid development and modifications of VI's to make them fit any new customer's demands. Additionally, these features make it possible to involve the system experts in the model (VI) development process.^{5,6} The approach and methodology utilized in this work was developed and demonstrated in earlier research by the author.⁷

3.2 Automating the Transfer of Data between Applications

Very early in the Team I development effort it was recognized that to have high-end tools with unique file formats work together in a near real-time fashion, there was a need for developing effective ways of transferring data between them. Without this capability, too much time would be spent on duplicating manual data entries, and manually searching through and possibly modifying input and output files.

The Team I development group solved this problem by developing routines, (VI's) in G-code, for extracting information from, as well as for inserting code and values into any file type by the press of a button. For example, a routine has been built for automatically extracting mass data from a summary mass file from MDT, transferring it to, and displaying it on the system station. An associated routine transfers this mass data from a system station file into assigned cells in the parametric cost model spreadsheet. Another routine has been developed for inserting orbital elements and other variables from the system station into a unique SOAP formatted orb. file. Through the push of a

button on the system station, SOAP opens up this file and displays visually the orbit of the instrument, its ground track, and any other parameters defined from the system station. The latter routine shows how G-code can be used for opening applications and files, a capability that will be useful for performing semi-automatic trade studies, with people in the loop, across a number of tools. These types of trade studies will be looked into in later phases of the Team I development effort.

3.3 Sharing Common Geometry

The largest time savings seem to come as a result of the optics, the CAD, and the thermal tools being able to utilize the same geometric data. These time savings can be attributed to progress made by the developers of these tools, and the mix and the utilization these tools in the Team I environment. In many ways, the requirements of Team I forced an effective integration of the optics, CAD, and thermal tools.

According to mechanical designers who have been designing support structures, fasteners, etc. for space instruments for a number of years, the Team I approach, typically, saves them 7-10 days worth of work. Up to recently, they had to manually translate the dimensions and positions (x, y, z) of lenses, mirrors, and detectors from, for example, a Code V output file, into a 2D CAD drawing. Often, such output files would be provided as print outs. In the Team I environment, these steps are eliminated, and the geometry of the optics configuration (dimensions and positions) is transferred automatically without any human intervention, except for opening, and saving files, from the optics tools to the CAD tools. The details of how this is done is discussed in section 2.2, The Process.

On the thermal side, the situation was similar. Dimensions and positions (x,y,z) of surfaces had to manually be read from a CAD drawing and then typed into, for example, TRASYS or NEVADA formatted ASCII files. This procedure required that the analyst knew how to set up these fileformats, and that he/she also knew which commands to use for inserting dimension and position values. By using RadCAD instead, CAD geometry from MDT is utilized directly in the RadCAD environment. RadCAD, which works within MDT, provides a visual representation of the geometry, and surfaces to be analyzed, and provides the analyst with a graphical user interface. These features, according to thermal experts, may reduce the time for calculating, radiation interchange factors and orbital heat inputs by a factor of 5.

4. CONCLUSIONS

The Team I development is very much at its early stages. However, both team members and customers are starting to see the benefits of utilizing this concurrent and multidisciplinary design and analysis environment. Much good work has been done in interconnecting and making the Team I tools effectively work together. There is still much work to do in this area, especially in transferring high level system parameters to the various applications. More work is also needed in developing high level preliminary analyses capabilities. Later, as more operational experience is gained, the Team I concept will be expanded to include design and analysis capabilities for non optical space instruments and in-situ instruments. From this perspective, the Team I environment can be seen as a laboratory for developing effective early conceptual design environments for demanding types of space instruments.

5. ACKNOWLEDGMENTS

During the Team I development effort, the author has benefited from discussions with numerous people at JPL, especially, listed alphabetically, Apostolis Deslis, Edward C. Hagerott, Randall C. Hein, Pantazis Mouroulis, David D. Norris, Stanley W. Petrick, James F. Schmidling, George Siebes, Jeffrey L. Smith, Harold R. Sobel, and Fred Vescelus.

The research described in this paper was carried out by the Jet Propulsion Laboratory, California Institute of Technology, under a contract with the National Aeronautics and Space Administration. Reference herein to any specific commercial product, process, or service by trade name, trademark, manufacturer, or otherwise, does not constitute or imply its endorsement by the United States Government or the Jet Propulsion Laboratory, California Institute of Technology.

6. GLOSSARY

Aperture diameter: The diameter of the opening through which light passes to reach the optics and the detectors in an optical or photographic instrument

Argument of Periapsis: Angle from the ascending node to periapsis measured in the direction of a satellite's motion.

E#: Defined as the focal length of the instrument (f) divided by the aperture diameter (D).

Field of View (FOV): Angular extent of field which can be observed by a spacecraft or an instrument.

Focal Length: The distance from a lens or a mirror to the point on the optical axis where parallel rays of light converge (the Focal Point).

IGES: Initial Graphics Exchange Specification is a standard file format for exchange of CAD data. IGES 1.0 was accepted as an American National Standards Institute (ANSI) standard in 1981.

Noise Equivalent Temperature (NEAT): Defined as the minimum ΔT within a scene element required to produce a change in the electrical signal level numerically equal to the root mean square (RMS) of the electrical system noise. Used as a figure of merit for Infrared (IR) systems.

Orbital Inclination: The angle between the angular momentum vector, perpendicular to the orbital plane of a satellite, and the spin axis of the body being orbited.

Radiometry: A specialist field dealing with issues related to the measurement of the intensity or force of different types of radiation.

Right Ascension of Ascending Node: Angle from the Vernal Equinox to the ascending node. Ascending node is defined as the point where a satellite passes through the equatorial plane from south to north. Right ascension is defined as a right-handed rotation about the pole.

Semi Major Axis: Half the distance between the apoapsis and periapsis points of an elliptical orbit

Spectral resolution: Number of bands that a given spectral range can be divided into

True Anomaly: The angle from the eccentricity vector to the position vector of the satellite. The angle is measured in the direction of the satellite motion.

REFERENCES

1. Casani, K. Thomas, N., *FST - Faster, Better, Cheaper*, SPIE-94, Conference.
2. Project Design Center, Jet Propulsion Laboratory (JPL), Brochure JPL 400-533, July 1994.

-
- 3 Oxnevad, K. I., "A Concurrent Design Approach for Designing Space Telescopes and Instruments", Paper 3356-131, 9, Proceedings from the Space Telescopes and Instruments V Section of the SPIE Astronomical Telescopes & Instrumentation Conference, Kona, Hawaii, March 20-28, 1998
 4. Oxnevad, K. I., *A Total Systems Analysis Method, for The Conceptual Design of Spacecraft: An Application to Remote Sensing Imager Systems*, Old Dominion University, Ph.D. Dissertation, pp. 13-22, May 1996.
 5. Wise, R.M., "LabVIEW our Choice for Cardiothoracic Research", Instrumentation Newsletter, Technical News from National Instruments, Vol. 7, p. A-5, Autumn 1995.
 6. Clarkson, M., "Tools on the Fly: Virtual Instruments Take Off", Desktop Engineering, pp. 20-28, September/October 1995.
 7. Oxnevad, K. I., pp. 1-96.



NASA ADVANCED FUELS PROGRAM

Bryan Palaszewski
NASA Glenn Research Center
Cleveland, Ohio

ABSTRACT

NASA with the USAF Research Laboratory and its industry partners, has been conducting planning and research into advanced fuels. This work is sponsored under the NASA Advanced Space Transportation Program (ASTP). The current research focus is on Alternative Hydrocarbon fuels, Monopropellants, and Solid Cryogenics for storing atoms of Hydrogen, Boron, Carbon, and Aluminum.

Alternative hydrocarbons that are under consideration are bicyclopropylidene, spiro pentane, and tripropargyl amine. These three fuels have been identified as initial candidates to increase the specific impulse of hydrocarbon fueled rockets by 10-15 seconds over O₂/RP-1. Formulation of these propellants is proceeding this year, and rocket engine testing is planned for the near future.

Monopropellant investigations are focused on dinitramine based fuels, and potential collaborations with the US Navy. The dinitramine fuel work is being conducted under an Small Business Innovation research (SBIR) contract with the team of Orbital Technologies Corp. (Madison, WI) and SRI (Menlo Park, CA). This work may lead to a high density, high specific impulse monopropellants that can simplify the operations for launch vehicles and spacecraft.

Solid Cryogenics are being considered to store atoms of Hydrogen, Boron, Carbon, and Aluminum. Stored atom propellants are potentially the highest specific impulse chemical rockets that may be practical. These fuels are composed of atoms, stored in solid cryogenic particles, suspended in a cryogenic liquid or gel. The fuel would be fed to a rocket engine as a slurry or gelled cryogenic liquid with the suspended particles with the trapped atoms. Testing is planned to demonstrate the formation of the particles, and then characterize the slurry flows.

Rocket propellant and propulsion technology improvements can be used to reduce the development time and operational costs of new space vehicle programs. Advanced propellant technologies can make the space vehicles safer, more operable, and better performing. Five technology areas are described: Monopropellants, Alternative Hydrocarbons, Gelled Hydrogen, Metallized Gelled Propellants, and High Energy Density Materials. The benefits of these propellants for future vehicles are outlined using mission study results and the technologies are briefly discussed.

INTRODUCTION

Space exploration and utilization require vehicles that are operable, safe, and reliable. Technologies for improving rocket performance are also desirable. As space missions become more ambitious, the needs for reducing cost and increasing the capability of rocket systems will increase. Propellant technologies have the power to make space flight more affordable and deliver higher performance.

Throughout the world, a new set of space related activities is being formulated. Many nations are taking advantage of the powerful view of Earth from orbit and beyond. New space activities in the USA are planned which include small expendable boosters, larger reusable launch vehicles, high speed aircraft, and new small spacecraft for many commercial and civilian space operations.¹ These new space planning activities have identified the need for new lower cost ways of gaining access to space, and much effort is being expended on this difficult issue. The cost of space access is particularly vexing, as many people and much infrastructure is usually associated with large orbital aerospace and rocket vehicles. One option to reduce space access costs is propellant technologies. Advances made over the last 60 years in propellants have shown that propellants can be made safer, less costly, and/or more energetic.²⁻⁴ Investing in propellant technologies can provide benefits across the board to all major international programs and the NASA Enterprises.^{1,5,6,7}

With the recent advent of reusable launch vehicles (RLVs),⁷⁻¹² the investigation of combined cycle and combination propulsion,^{13,14,15} and the development of small boosters for low cost spacecraft,^{5,6,16,17} the interest in advanced propellants has risen. With RLVs, the need is for propellants that improve the vehicle mass fraction, as the goal of single stage to orbit makes unceasing demands on the performance of lightweight materials, cryogenic systems, and, of course, rocket propulsion. Combined and combination propulsion, using both air-breathing and rocket propulsion, are another set of options for single stage and two stage to orbit vehicles. These vehicles will also stress the limits of many technologies, and high density, high energy hydrocarbons and hydrogen will be needed. Advanced cooling techniques with endothermic fuels is also attractive for many applications. Small boosters are also in vogue. The use of small boosters for space access has become more attractive, especially for entrepreneurs attempting to use space for profitable gain, and universities who wish to use space flight, satellite construction, and satellite operation as learning tools.

High speed aircraft, with fleet foot, perhaps approaching orbital velocities, are also in the plans for commercial gain, national power projection, observation, and space access.^{7,8,13,14,15} These aircraft require cooling technologies for their airframes as well as for their internal systems, passengers, and payloads. Typically, the fuel is used as a heat absorber, but hypersonic flight requires cooling capacities that exceed that of traditional fuels. Endothermic fuels have the capacity to thermally break up and split into components. This breakup of the fuel absorbs heat and increases the fuel cooling capacity.

Many studies have shown the powerful leverage gained with high performance upper stages.^{18,19,20} High specific impulse propellants with high density can reduce the size of launch vehicles, thereby permitting the performance of the same mission with a smaller launch vehicle and reducing the cost of space access. Improving these upper stages has led to the use of O₂/H₂ propellants, but the low density of H₂ has hampered the ability of upper stages to be packaged in a small volume. The search for higher propellant and stage density has led in several directions. Additives to H₂ or the use of alternative hydrocarbons may allow the upper stage to deliver the same payload performance while occupying a smaller volume, and reduce the overall launch vehicle mass and cost.

Spacecraft propulsion technology improvements are critically important in reducing space vehicle costs.²¹⁻²⁴ Reducing the mass and size of the spacecraft, as well as its upper stages, can reduce the size of the launch vehicle needed. As the propulsion system is often the largest and most massive component of a spacecraft, there is a powerful leverage to be gained with higher density, higher performance propellants. Size reductions can often allow the integration of functions that further reduce overall vehicle costs, such as the combining of apogee propulsion for orbit circularization, and the use of the same propellants and engines for on-orbit maneuvering and orbit maintenance.

The future also beckons with new propellants born of the computer and the propellant designer.^{25,26} Many dream of harnessing the most powerful chemical bonds between individual atoms of hydrogen, boron, carbon, and aluminum. The atoms, once created, are arrested within a cryogenic solid, and released as they enter the rocket engine. Though these propellants are currently difficult to fabricate in large quantities, there is hope that the power of molecular manipulation from microtechnology, and

ultimately nanotechnology, will make these new, and in some cases not yet known, propellants a shining reality.

One of the five major areas of propellant technologies will be discussed in the paper. The influence of these technologies on vehicle design, some of the current research interests, and the status of the technologies will be addressed. A short overview of the importance of density and specific impulse is also provided to illustrate the main issues in the development of propellant technologies.

DENSITY AND SPECIFIC IMPULSE

Liquid rocket propellants are often the largest volume aboard a rocket vehicle. Their large volume must be contained by very large, bulky, heavy tanks that keep the liquids at the right pressure and temperature until they are used in a rocket engine. An increase in the density, or mass per volume, can reduce the mass of the tanks, structure, and other parts of the rocket that are dependent upon the volume of the propellants. Higher density propellants are therefore an excellent way to improve the performance of rocket vehicles, because they will reduce the mass of the tanks and the associated components. Reducing the mass of the rocket will also lead to reducing the weight of fuel needed to move the rocket, so there is a powerful cascade effect that occurs when reducing the mass of rockets and the amount of fuel.

Reducing the weight of a rocket is also made possible by using a higher energy fuel, because less fuel is needed. This energy is related to the exhaust velocity or specific impulse of the rocket engine, essentially a miles-per-gallon analogy for rockets. The higher the energy of the fuel, the higher the specific impulse. Adding energy to the fuel by changing its chemistry, gelling the fuel, or gelling and adding particles of metal or other higher energy compounds, can increase the specific impulse.

Several ways of increasing the density of the propellants have been used in the past. One way of increasing propellant density is to create a special chemical mixture with high density, such as a high density salt that is soluble in water. Another way is to use very high density chemical fuels existing in nature: aluminum, boron, or other metals. A third way is to add small metal particles, or frozen liquid particles, and suspend them in the fuel or oxidizer. A gelling agent is used to thicken the fuel and allow the suspension of the solid particles. The gelling agent may be frozen liquid particles, solid particles, or long-chained liquid polymers. Gelling the fuel, without adding metal particles, can also increase the density and change the energy of the fuel. The gelling agent can add energy and increase the density by itself, but the energy and density increases are much larger if metal additives are also used.

With these ideas of increased density and specific impulse in mind, the five technologies are described and their applications and effect on future missions is discussed.

THE TECHNOLOGIES

Five major areas have been identified for fruitful research. The five areas are Monopropellants, Alternative Hydrocarbons, Gelled Hydrogen, Metallized Gelled Propellants, and High Energy Density Propellants. During the development of the NASA Advanced Space Transportation Plan, these technologies were identified as the most likely to have high leverage for new NASA vehicles for each of the Enterprises.¹ This work is continuing under other programs, recently realigned under the Three Pillars of NASA: Global Civil Aviation, Revolutionary Technology Leaps, and Access to Space.

MONOPROPELLANTS

Current spacecraft and satellite users and manufacturers are looking for more environmentally benign, safer propellants.²⁷⁻³² Environmental, safety, and cost concerns with hydrazine (N₂H₄) and its derivatives have led to the development of monopropellants with a high water content and high energy additives. Monopropellants, based on hydroxyl ammonium nitrate (HAN), have a density that is up to 1,400 kg/m³, about 40% higher than hydrazine.³² The potential specific impulse of these monopropellants

is in the range of 210 to 270 seconds. Though the first versions of the fuels may have comparable or lower specific impulse than hydrazine, the cost associated with launch processing and the ground crew's safety are significantly reduced with the new monopropellants. Safer propellants can reduce costs by eliminating the need for the self-contained atmospheric protective ensemble (SCAPE) suits³³ that are needed for toxic propellants. Also, extensive and prohibitive propellant safety precautions, and isolation of the space vehicle from parallel activities during propellant loading operations can be minimized or eliminated.^{27,31,32} If these fuels are used on future satellites, the operating costs will be lowered, in some cases dramatically. Monopropellant testing of HAN-based fuels has begun to show promise and will soon be adopted for on-board propulsion systems on communications satellites and LEO satellites and constellations.^{21,31,32}

The formulation of HAN-based propellants is variable, based on the specific mission application, and the advances in technology that may occur as the propellant and the propulsion systems are being developed.³² A current version of the HAN-based propellant is composed of 50 to 61 % HAN, 20 to 40% water, a fuel and a number of additives to stabilize the mixture for long term storage.³² A formulation based on the U.S. Army Liquid Propellant Gun testing using Di Ethyl Hydroxyl Ammonium Nitrate (DEHAN) has been considered: 60.7% HAN, 20% water, and 19.3% DEHAN. The civil space versions of the HAN- based monopropellant will limit the use of DEHAN, and do not use Tri-Ethyl Ammonium Nitrate (TEAN), as the TEAN has been found to be incompatible with, or limits the lifetime of, some propulsion system igniter materials. Fuels that have low or no carbon content will minimize the potential for damaging any potential catalyst igniter materials, and are preferred to minimize the molecular weight of the exhaust.

Technologies for igniting the monopropellants are important. Current monopropellants use a catalytic ignition system, but some of the high energy additives can foul the catalyst, making it less effective. Laser and combustion wave ignition are potential alternatives. Materials compatibility of the monopropellants with the tank materials is also very critical for long term space missions. Polymeric liners or chemical passivation of metallic fuel tanks may be required to alleviate this problem. The high water content of the monopropellant will create a highly oxidizing environment in the rocket chamber and nozzle. High temperature coatings will be required to minimize the chemical attack of the exhaust on the rocket engine walls.

Advanced monopropellants are potentially simpler to handle than traditional bipropellants, and have a density comparable to solid rocket motors. Figure 1 shows the benefits of monopropellants for Liquid Rocket Boosters (LRB) for the Space Shuttle. The monopropellant shown here is Tri-Ethylene Glycol Dinitrate / Ammonium Perchlorate / Aluminum. (or TEGDN /AP /Al).³⁴ It can reduce the overall gross liftoff weight (GLOW) of the Shuttle, and reduce the booster length, making them more compact. The GLOW of the Space Shuttle is reduced by 9.3 percent when using a TEGDN/AP/Al monopropellant LRB. The booster length for this option is 37.8 meters. By allowing the booster length to grow to 43.3 meters, the payload is increased from 22,527 kg to 31,979 kg, and the resulting booster is still considerably shorter than the 45.4-meter long SRB, as shown in Figure 1. These options for increasing payload and reducing booster length give the designer more options that can lead to further reductions in vehicle mass and increases in payload performance.

Other monopropellants using gelled fuels can also improve performance and increase safety.³⁴ Gelled hydrogen peroxide (H₂O₂) and liquid TEGDN/AN/Al have the potential for very high density, excellent performance, and safety. Metal particles could be added to the gelled H₂O₂, further increasing its density.

REFERENCES

- 1) "NASA Strategic Plan," NASA Headquarters, Washington, DC, February 1996. See also - <http://www.canaryon.com/internet/ciencia/nasa/table.htm>

- 2) Huzel, D. and Huang, D., *Modern Engineering for Design of Liquid Rocket Propellant Engines*, AIAA Progress in Astronautics Series, Vol. 147, Washington, DC, 1992.
- 3) Wells, W., "Metallized Liquid Propellants," *Space /Aeronautics*, Vol. 45, June 1966, pp. 76-82.
- 4) Sanger, E., *Raketenflugtechnik*, Berlin: R. Oldenberg, 1933, pp. 53.
- 5) Naumann, W., "Small Launchers in the Future: A Global Overview of the Features and Prospects," *Acta Astronautica*, Vol. 37, pp. 471-486, Pergamon Press, 1995.
- 6) Fleeter, R., McLoughlin, F., and Wanagas, J., "Earth to Orbit Transportation Optimized for Small Low-Cost Satellites," AAS 91-646, International Space Year in the Pacific Basin, 1991 Conference, Univelt Publishing, 1992, pp 377-392.
- 7) Takahashi, S., Mizobata, K., and Sawada, K., "Conceptual Design of a Two-Stage Air-Breathing Reusable Launch Vehicle," *Journal of Spacecraft and Rockets*, Vol. 34, Number 5, September-October 1997, pp. 628-635.
- 8) Godell, M., and Elrod, W., "Suborbital Launch Trajectories for Satellite Delivery," *Journal of Spacecraft and Rockets*, Vol. 32, Number 3, May-June 1995, pp. 411-416.
- 9) Boltz, F., "Payload Capability of a Kerosene-Fueled Mini Shuttle," *Journal of Spacecraft and Rockets*, Vol. 34, Number 5, September-October 1997, pp. 685-687.
- 10) Goracke, B.D., Levack, D., and Johnson, G., "Tripropellant Engine Option Comparison for Single Stage to Orbit," *Journal of Spacecraft and Rockets*, Vol. 34, Number 5, September-October 1997, pp. 636-641.
- 11) Lepsch, R. And Stanley, D., "Dual Fuel Propulsion in Single Stage Advanced Manned launch System Vehicle," *Journal of Spacecraft and Rockets*, Vol. 32, No. 3, May-June 1995, pp. 417-425.
- 12) Shirasu, H., South, J., and Martin, J., "Analysis of Concepts for Single Stage to Orbit," *Journal of Spacecraft and Rockets*, Vol. 33, No. 4, 1996, pp. 597-598.
- 13) Ganji, A.; Khadem, M; Khandani, Sm H., "Aerothermodynamic Analysis Of Combined-Cycle Propulsion Systems," *Journal Of Propulsion And Power*, Vol. 9, No. 1, Jan.-Feb. 1993, pp. 153-155.
- 14) Schmidt, D., and Lovell, T., "Mission Performance and Design Sensitivities of Air Breathing Hypersonic launch Vehicles," *Journal of Spacecraft and Rockets*, Vol. 34, No. 2, March-April 1997, pp. 158-164.
- 15) Ardema, M., Bowles, J., and Whittaker, T., "Near Optimal Propulsion System Operation for an Air Breathing Launch Vehicle," *Journal of Spacecraft and Rockets*, Vol. 32, No. 6, Nov.-Dec. 1995, pp. 951-956.
- 16) Hurden, D., "Liquid Propellant Sounding Rockets for Upper Atmosphere Research," *Journal of the British Interplanetary Society*, Vol. 19, Part 2, April 1963, pp. 25-31.
- 17) Garrett, H., and Rustan, P., "Clementine Engineering Experiments Program," *Journal of Spacecraft and Rockets*, Vol. 32, Number 6, November-December 1995, pp. 1045-1048
- 18) Holsten, H., "Development Of The Ariane 5 Upper Stage," *Acta Astronautica*, Vol. 29, No. 2, Feb. 1993, p. 117-12.

- 19) Martin, J., and Stewart, J., "Delta Improvement Study - Hydrogen Upper Stage," *Journal Of Propulsion And Power*, Vol. 11, No. 6, Nov.-Dec. 1995, pp. 1288-1290.
- 20) Doyle, S., Editor, "History Of Liquid Rocket Engine Development In The United States 1955-1980," AAS Rocket Propulsion History Colloquia. Vol. 1., Univelt, Inc. San Diego, CA, *AAS History Series*, Vol. 13, 1992, 174 pp.
- 21) Brown, Charles D., *Spacecraft Propulsion*, American Institute of Aeronautics and Astronautics, Inc., Washington, DC, 1996.
- 22) Pisacane, Vincent L. "Spacecraft propulsion, flight mechanics, and launch systems," in *Fundamentals Of Space Systems*, New York, Oxford University Press, 1994, pp. 173-243.
- 23) Rosenberg, Sanders D; Schoenman, Leonard, "New Generation Of High-Performance Engines For Space Propulsion," *Journal of Propulsion and Power*, Vol. 10, no. 1, Jan.-Feb. 1994, pp. 40-46.
- 24) Sackheim, Robert L; Zafran, Sidney; Wolf, Robert S., "Space Propulsion Systems," in *Space Mission Analysis And Design*, 2nd Edition, Torrance, CA/Dordrecht, Netherlands, Microcosm, Inc. /Kluwer Academic Publishers, 1995, pp. 637-664
- 25) Collins, G., et al., "Triggered Energy Releases in Solid Hydrogen Hosts Containing Unpaired Atoms," *Physical Review Letters*, Vol. 65, Number 4, pp. 444-447, July 23, 1990.
- 26) Lee, Timothy J., and Rice, Julia E., "Theoretical Characterization Of Tetrahedral N4," *Journal of Chemical Physics*, Vol. 94, Jan. 15, 1991, pp. 1215-1221.
- 27) Mueller, Kurt F; Czielsa, Manfred, J., "Monopropellant Aqueous Hydroxyl Ammonium Nitrate/Fuel," USA Patent No. 5,223,057, Filed March 28, 1969 , Dated June 29,1993.
- 28) Birk, A., McQuaid, M., and Bliesener, G., "Combustion Of HAN-Based Liquid Propellant Sprays at 28 to 38 MPa," *Combustion Science and Technology*, Vol. 106, No. 1-3, May 1995, pp. 1-17.
- 29) Kounalakis, M.E. and Faeth, G.M., "Combustion of HAN-Based Liquid Monopropellants Near the Thermodynamic Critical Point," *Combustion and Flame*, Vol. 74, Nov. 1988, pp. 179-192.
- 30) Messina, Neale A., Ingram, Larry S., Tarczynski, Marek, and Knapton, John D., "Ignition Mechanisms In Monopropellants," *Propellants, Explosives, Pyrotechnics*, Vol. 16, April 1991, pp. 88-93.
- 31) Wilson, Ben F., "Liquid Rockets," in *Tactical Missile Propulsion*, American Institute of Aeronautics and Astronautics, Inc. Reston, VA, Progress in Astronautics and Aeronautics. Vol. 170, 1996, pp. 33-55.
- 32) Jankovsky, R., "HAN-based Monopropellant Assessment for Spacecraft," AIAA Paper 96-2863, NASA-TM-107287, July 1996.
- 33) Lasley, M. L., "Physical, Anthropometrical, and Body Composition Characteristics of Workers at Kennedy Space Center," NASA-TM-83102, NAS10-10285, September 1, 1985.
- 34) Nieder, E., Harrod, C., Rodgers, F., Rapp, D., and Palaszewski, B., "Metallized Gelled Monopropellants," NASA TM 105418, April 1992.

**Liquid rocket booster (LRB) analysis
for a 50/30/20-wt% TEGDN/AP/Al monopropellant**

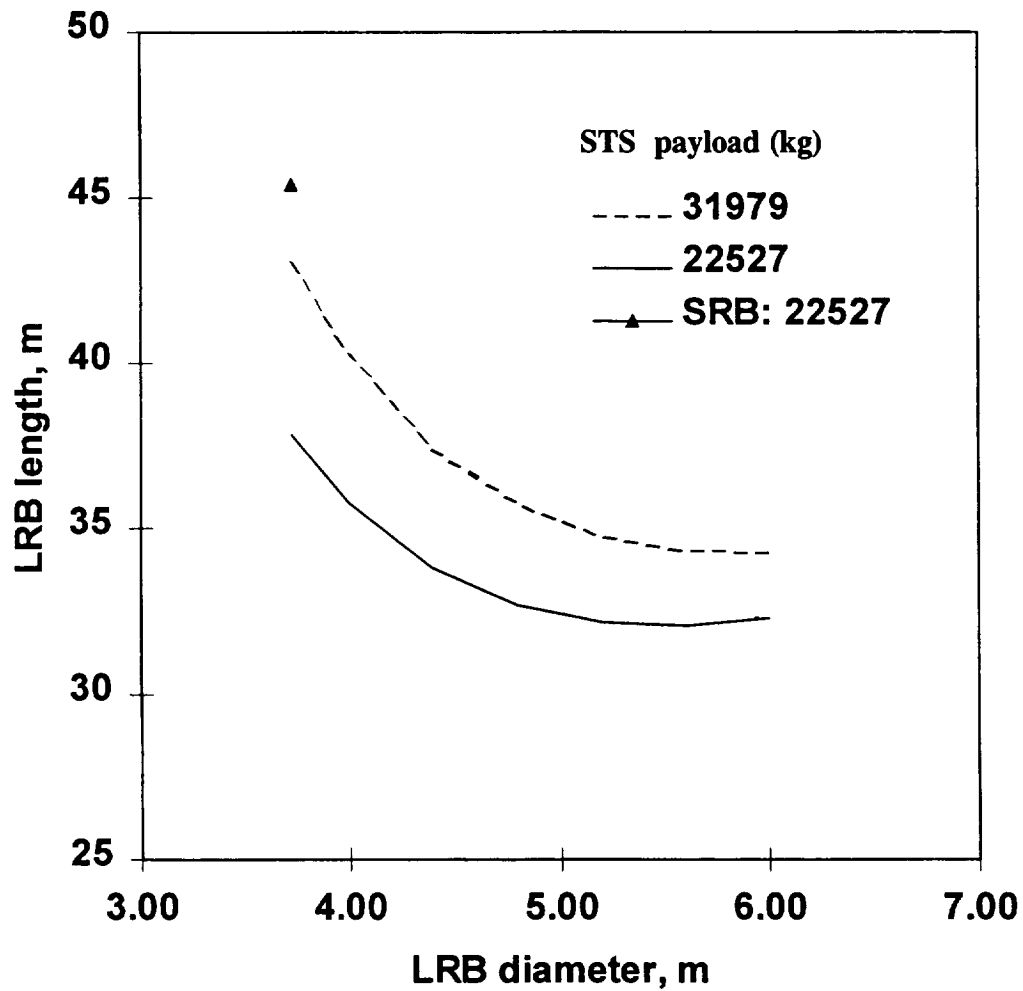

Figure 1. Monopropellant Liquid Rocket Booster length and diameter



MISSION PREPARATION AND TRAINING EQUIPMENT (MPTE) FOR THE
EUROPEAN ROBOTIC ARM (ERA)

Marcel Schoonmade
National Aerospace Laboratory NLR
The Netherlands

Content

- **MPTE project overview**
- **ERA introduction**
- **MPTE functions**
- **ISS/ERA pictures**
- **MPTE figures**
- **Current status and planning**

Project Overview

- **Goals:**
 - Prepare missions
 - Train cosmonauts and ground operators
 - Support missions (on-line & post evaluation)
- **By National Aerospace Laboratory (NLR) of the Netherlands (MPTE prime)**
- **Subcontractor Spacebel/Trasys of Belgium**
- **For Fokker Space (ERA prime), under ESA funding**
- **Cooperation/for RSC-Energia & Gagarin Cosmonaut Training Centre (GCTC), Russia**

Project Overview (cont'd)

- **Users:**
 - GCTC for training
 - Mission Control Centre (MCC) for preparation, control, evaluation of missions [incl. training]
 - ESTEC for support and flight software maintenance
- **Fokker contributes ERA Simulation Facility (incl. Fault injection and Path Planning) and Flight Software Maintenance Facility for NLR integration/adaptation**
- **Maximum (re)use of COTS software and hardware (e.g. Robcad, CGS, ESF, SGI, HP, Sun)**

ERA

- **Robot to help/relief cosmonauts (less/easier EVA)**
- **Tasks: assemble, exchange, inspect, move cosmonauts**
- **Relocatable (“leap frog”) manipulator arm; symetric, 7 DOF**
- **Launch to Russian Segment (RS) of ISS early 21st century**
- **ESA contribution under barter agreement**
- **MPTE is a facility used for ERA**

MPTE functions

- **Mission preparation**
 - on basis of Control Development Methodology (CDM), using
 - basic actions to build standard tasks, to build missions
 - validation:
 - path planning, simulation/visualization and checking (automated & procedural)
- **Training support for IVA & EVA cosmonauts and operators in real-time**
- **Online mission support: monitoring, analyzing ERA performance etc.**
- **Mission evaluation: replaying, analyzing ERA characteristics, trends, degradation etc.**
- **Facility management (configuration control, data exchange)**
- **Flight- and ground operational software maintenance**

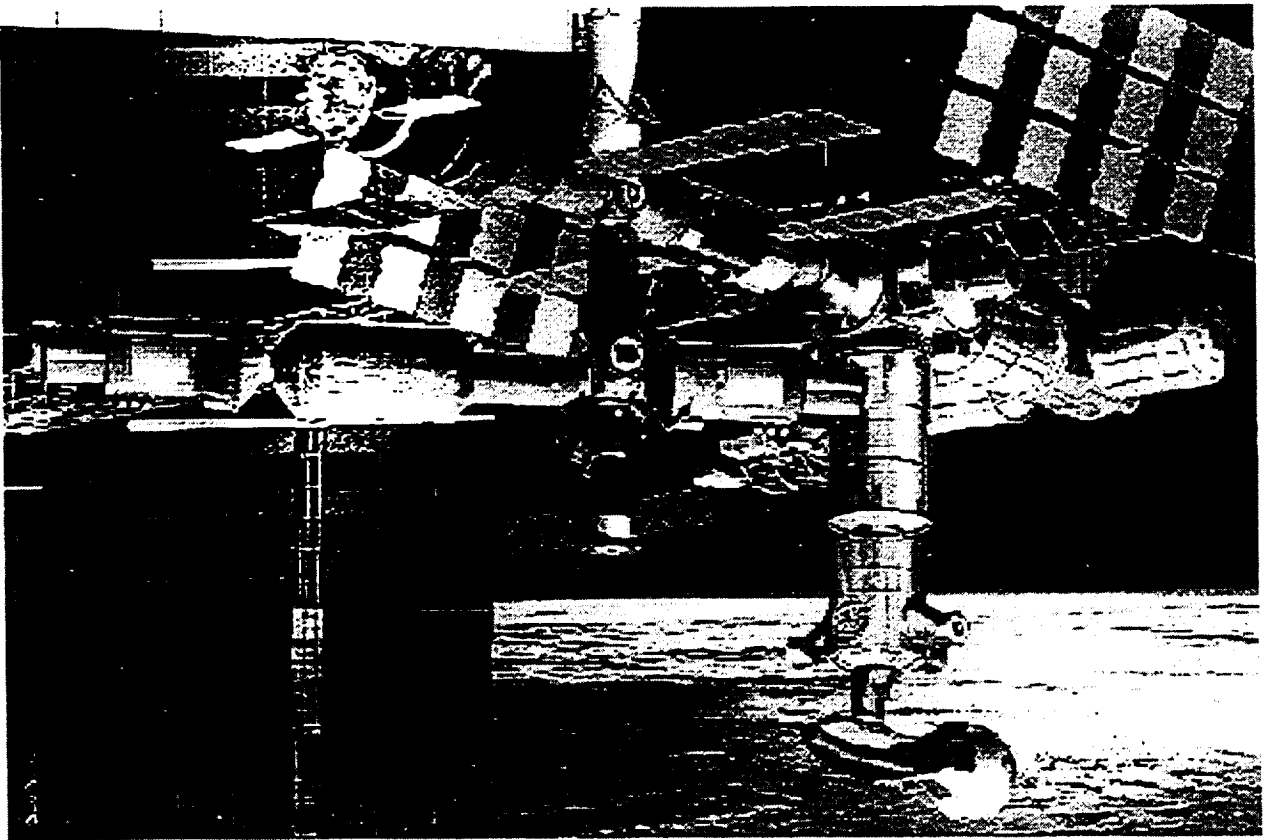
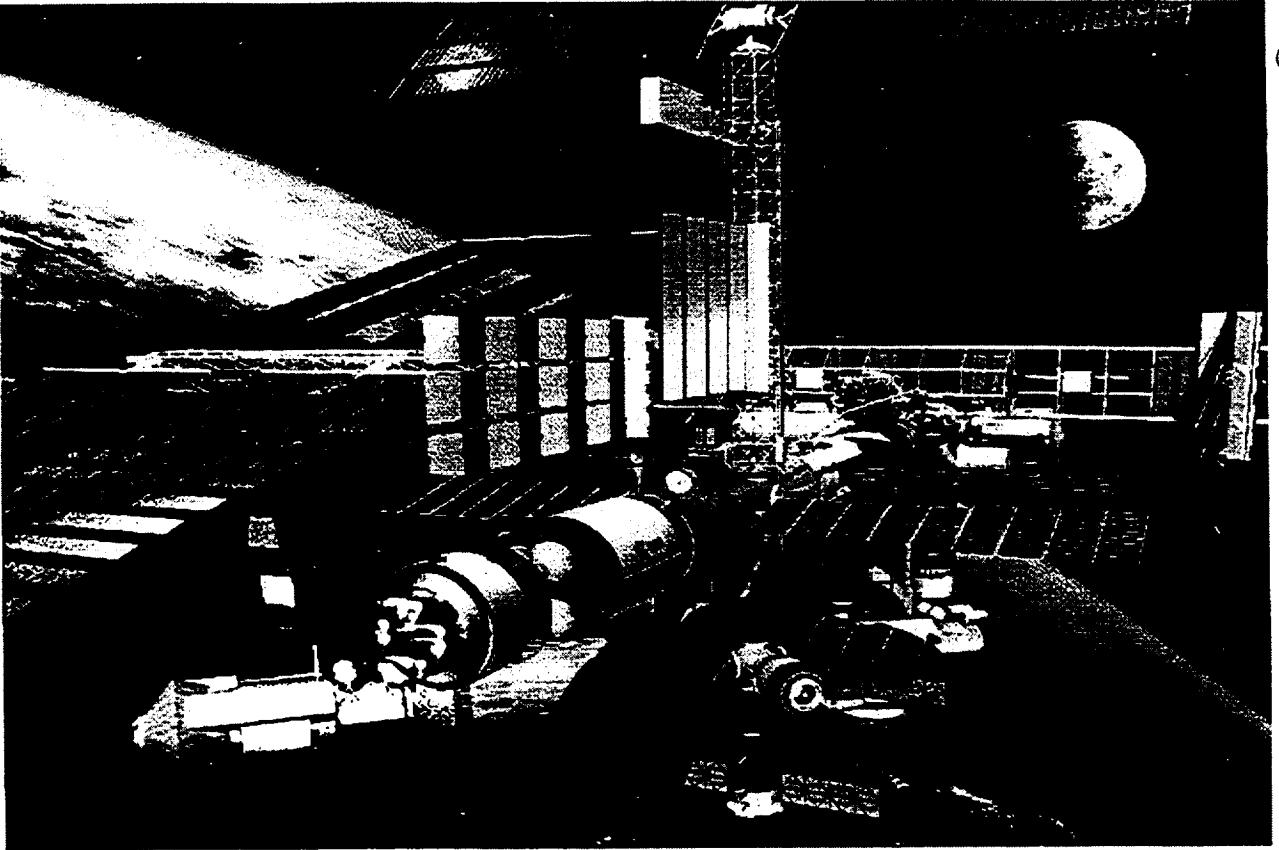

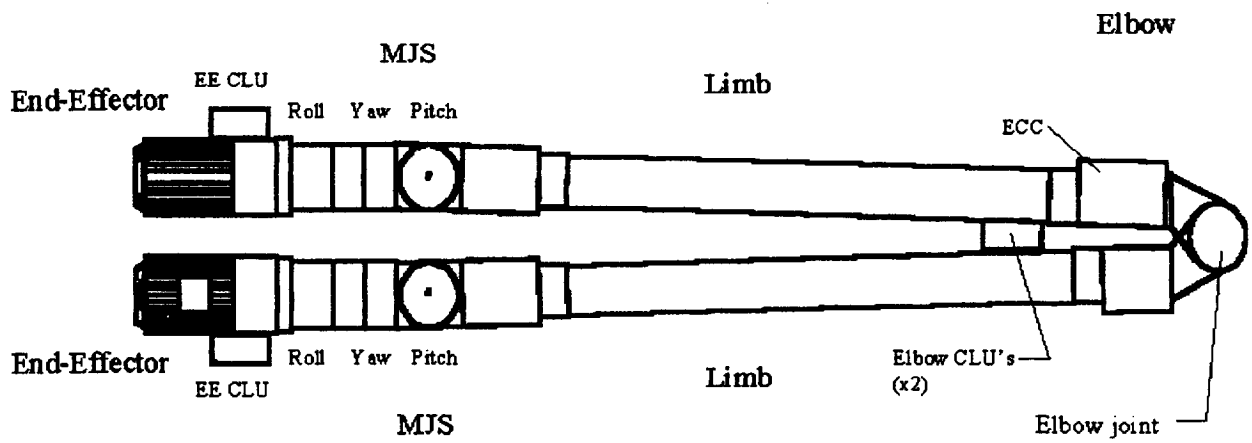
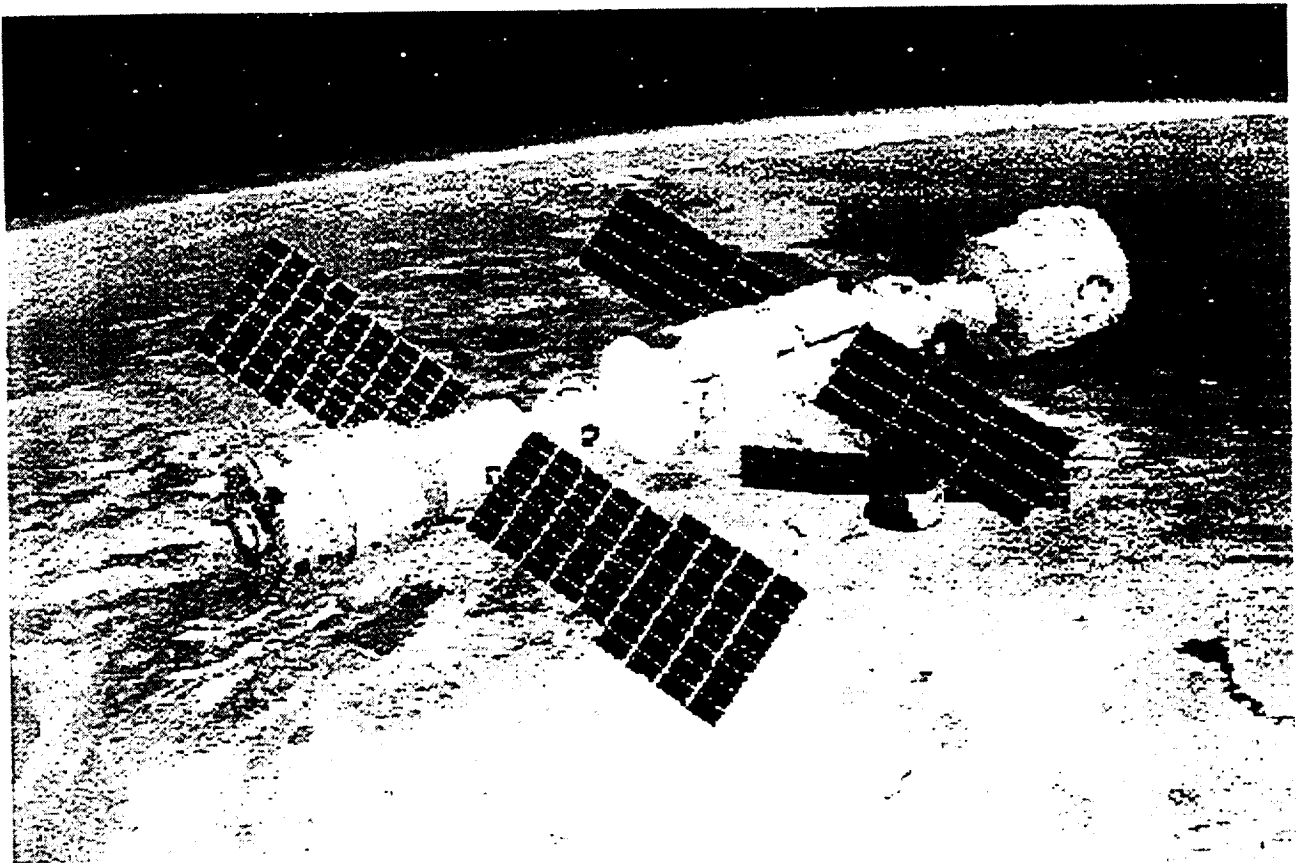

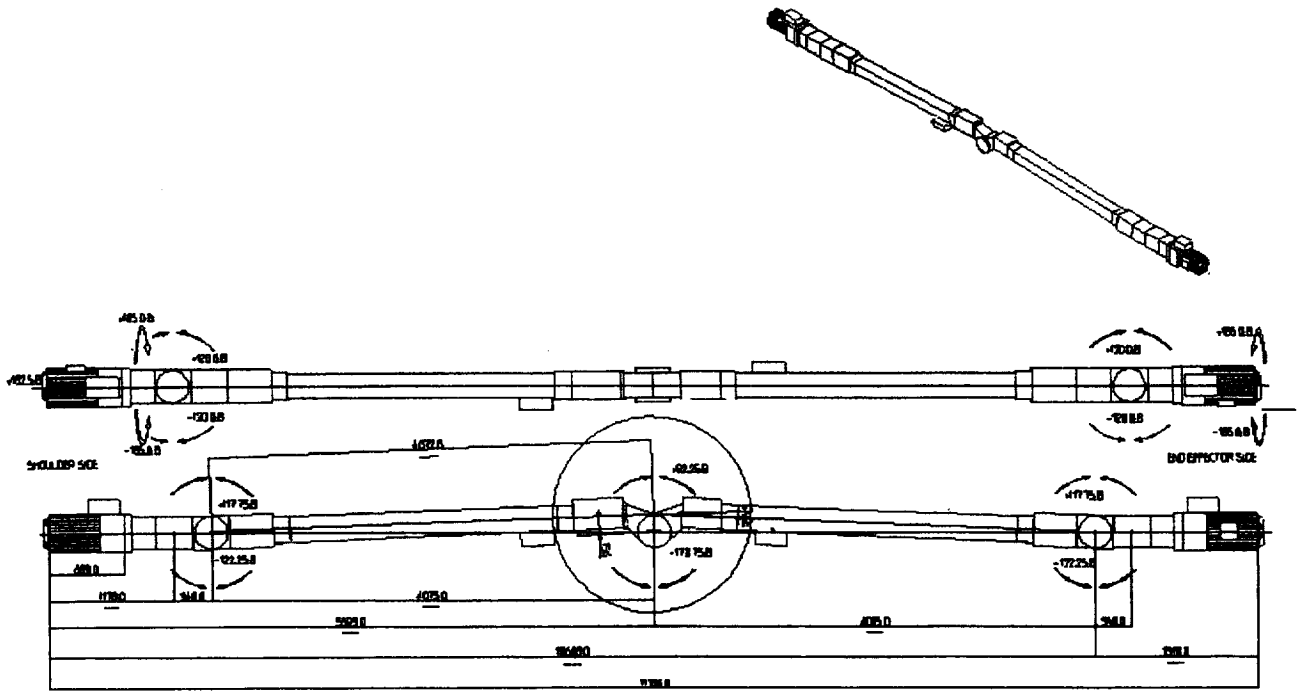

ALL JOINTS ARE IN ZERO DEGREE POSITION
 LIMIT SWITCHES - DEGREE NOM + 85 DEG
 ALL JOINTS

FREEDOM OF ROTATION ARE NOMINAL AND
 ACC. ARROWS, EXCL. 15 DEG END STOP
 FOR WRIST AND 7 DEG FOR DO STOP ELBOW

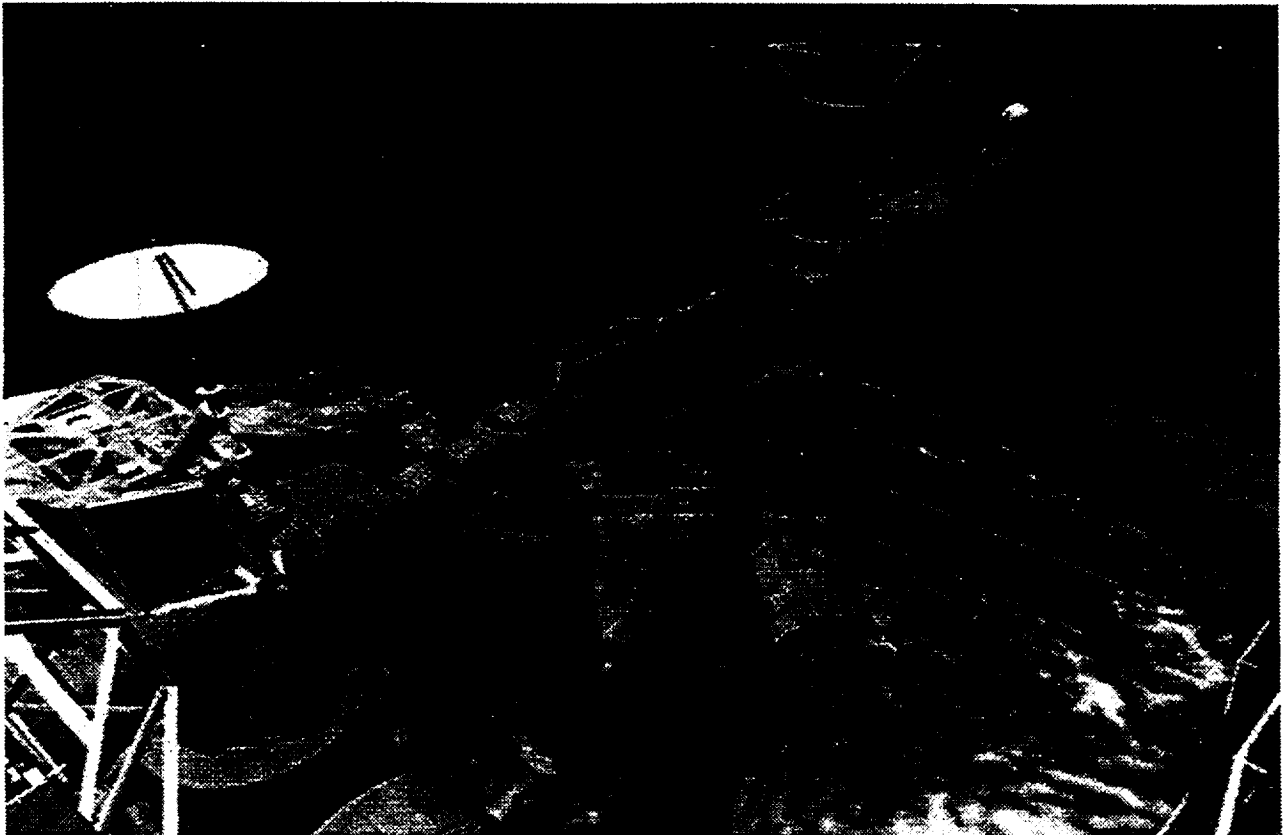

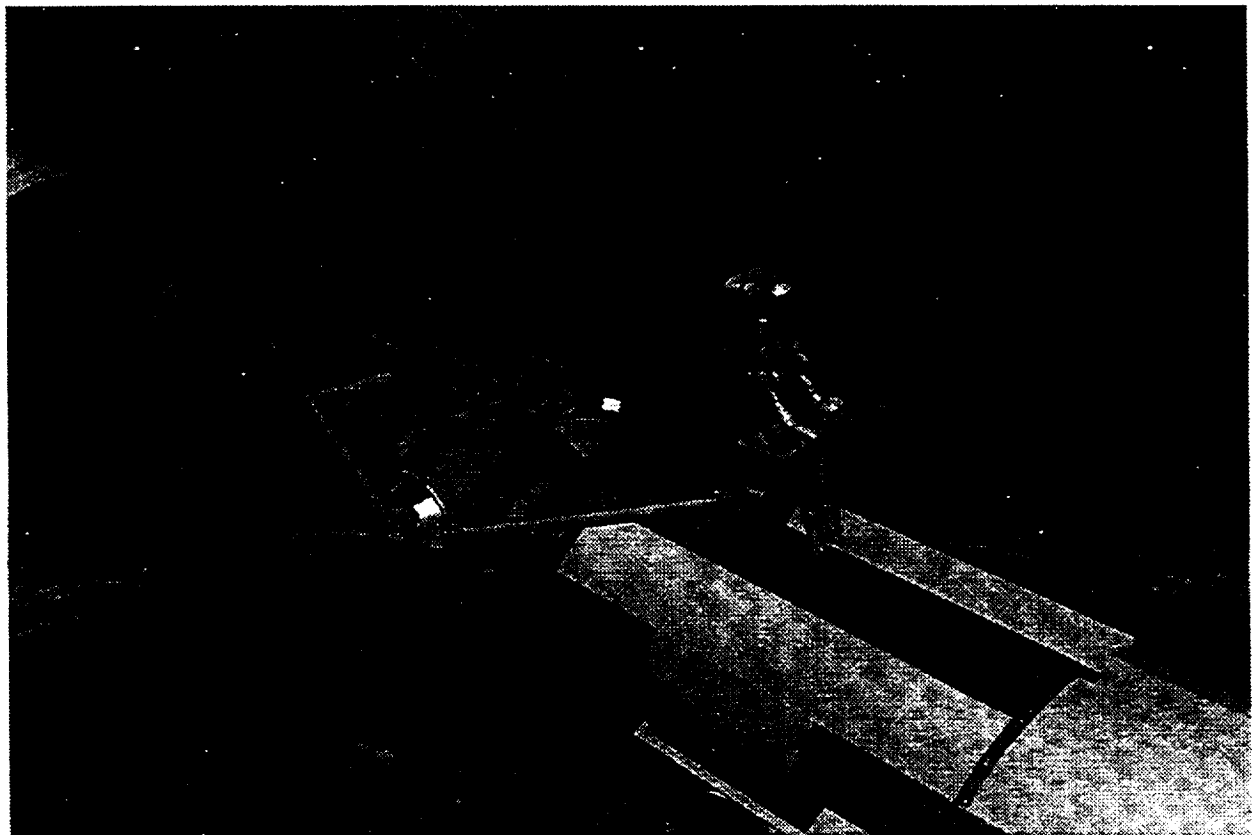
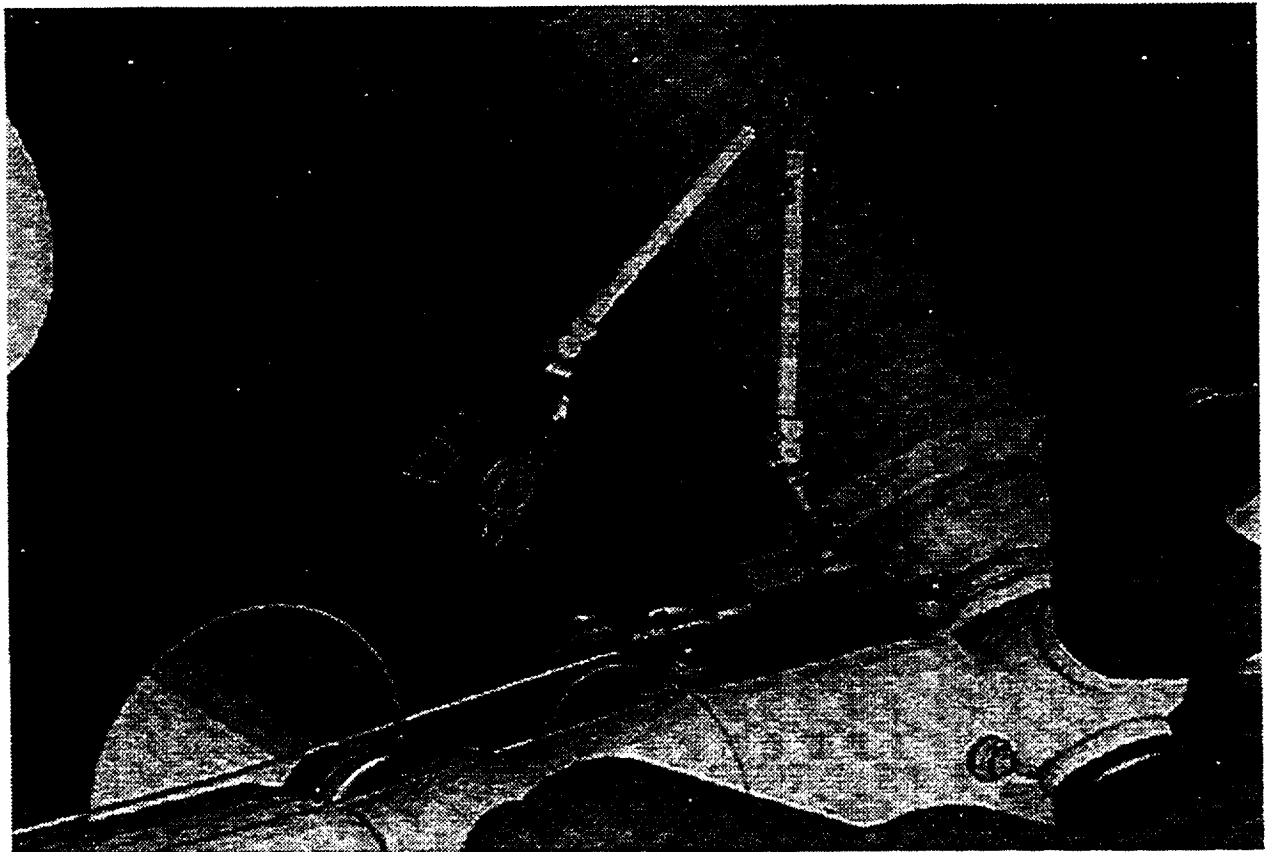

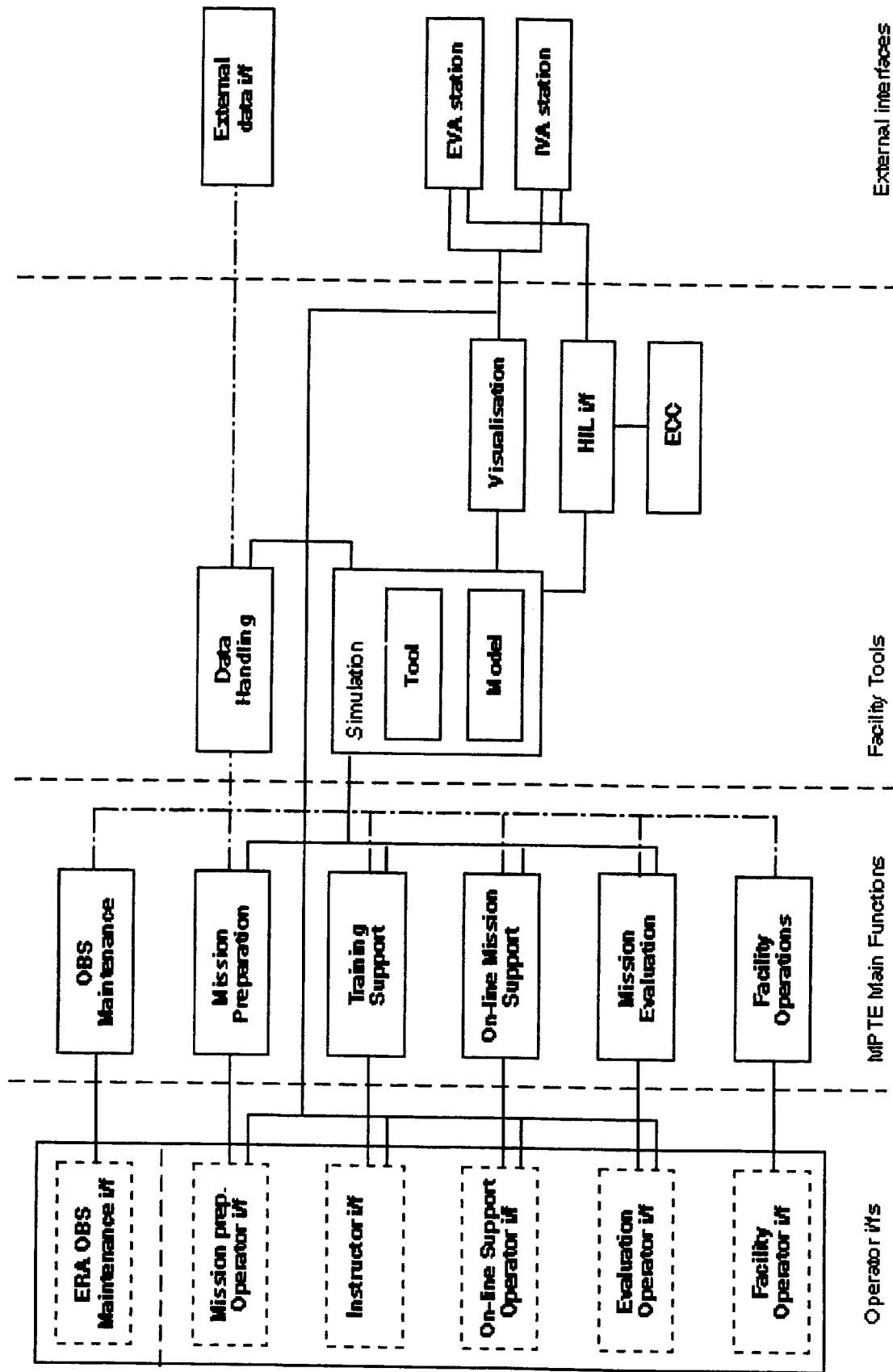

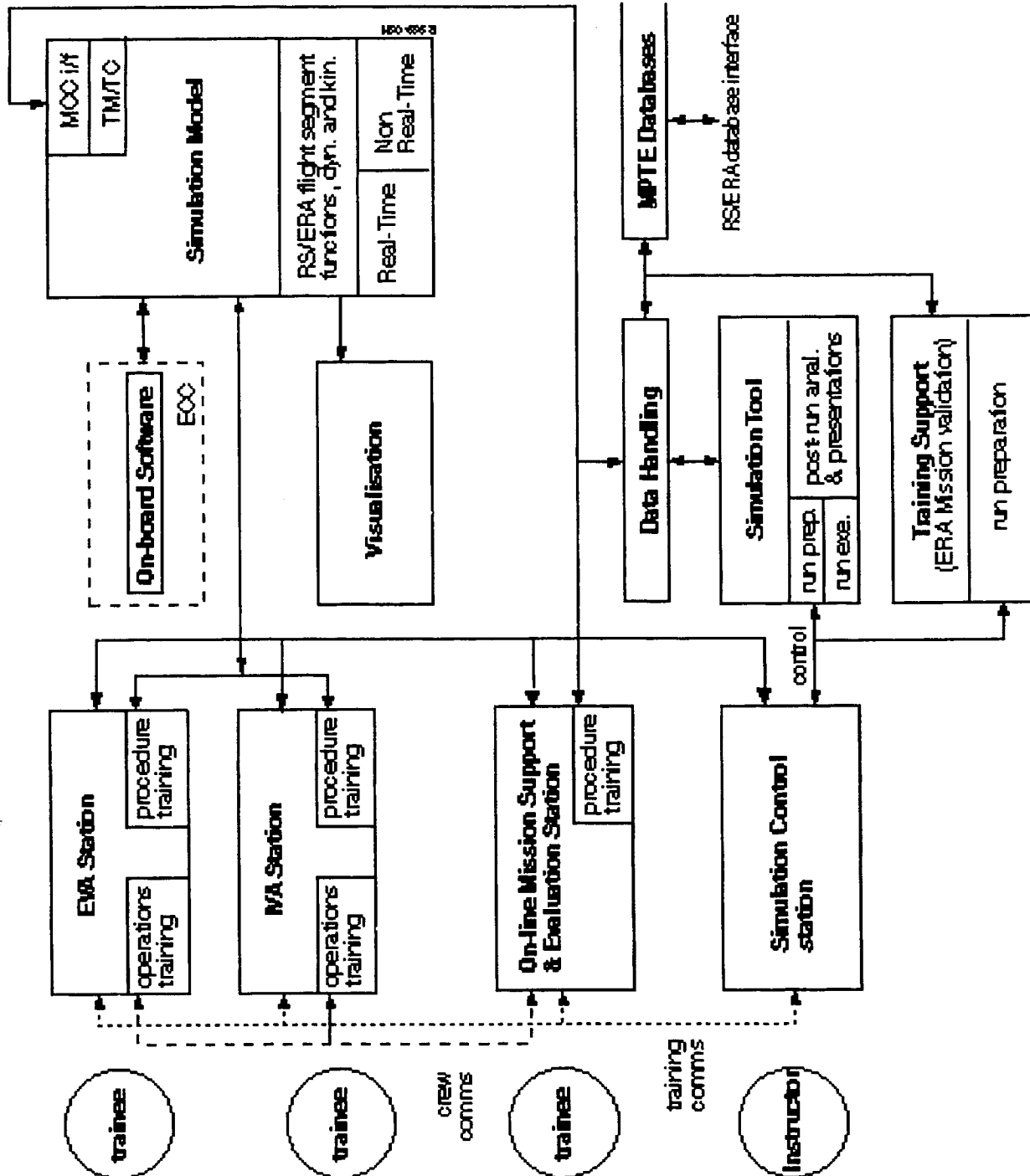

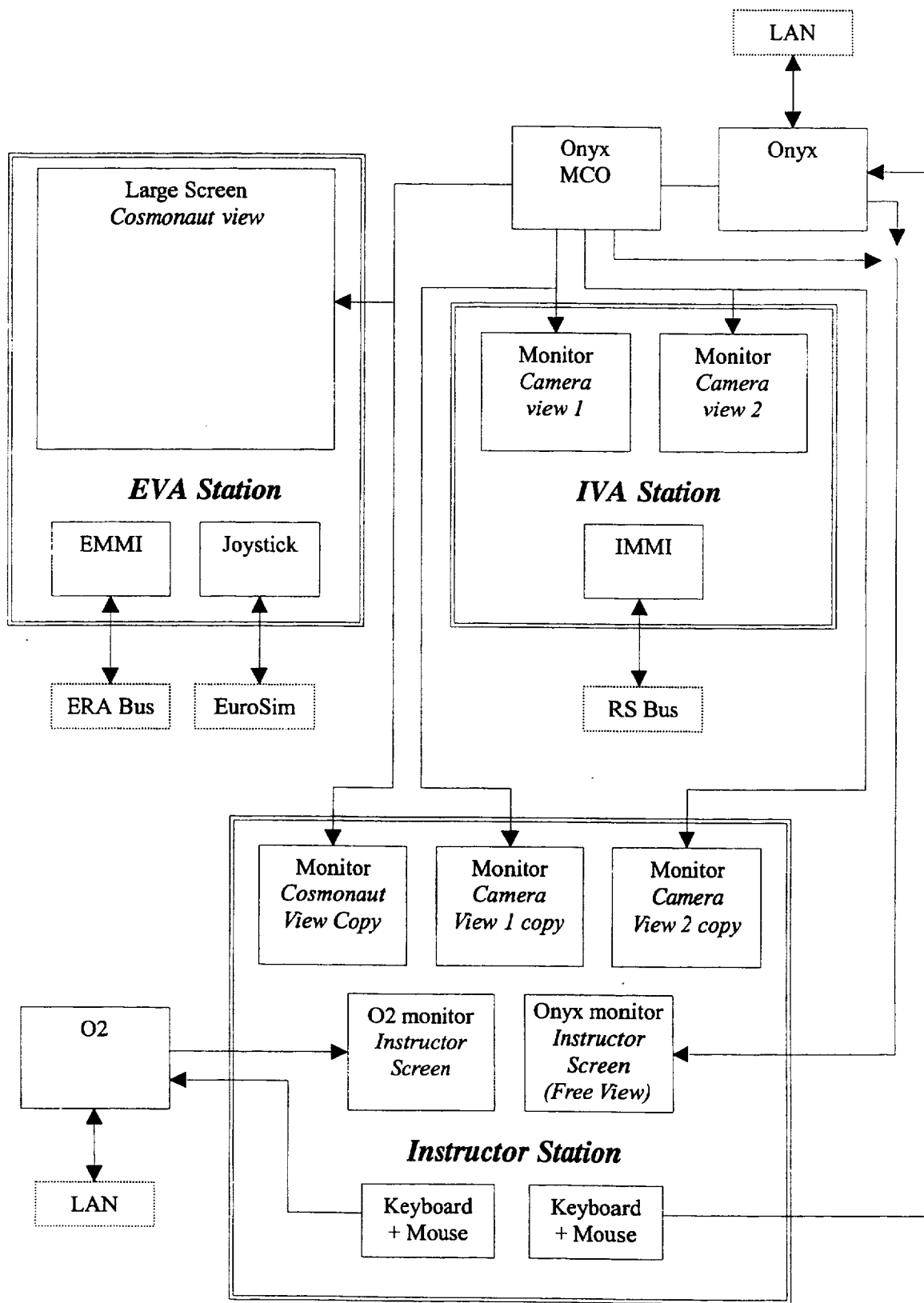

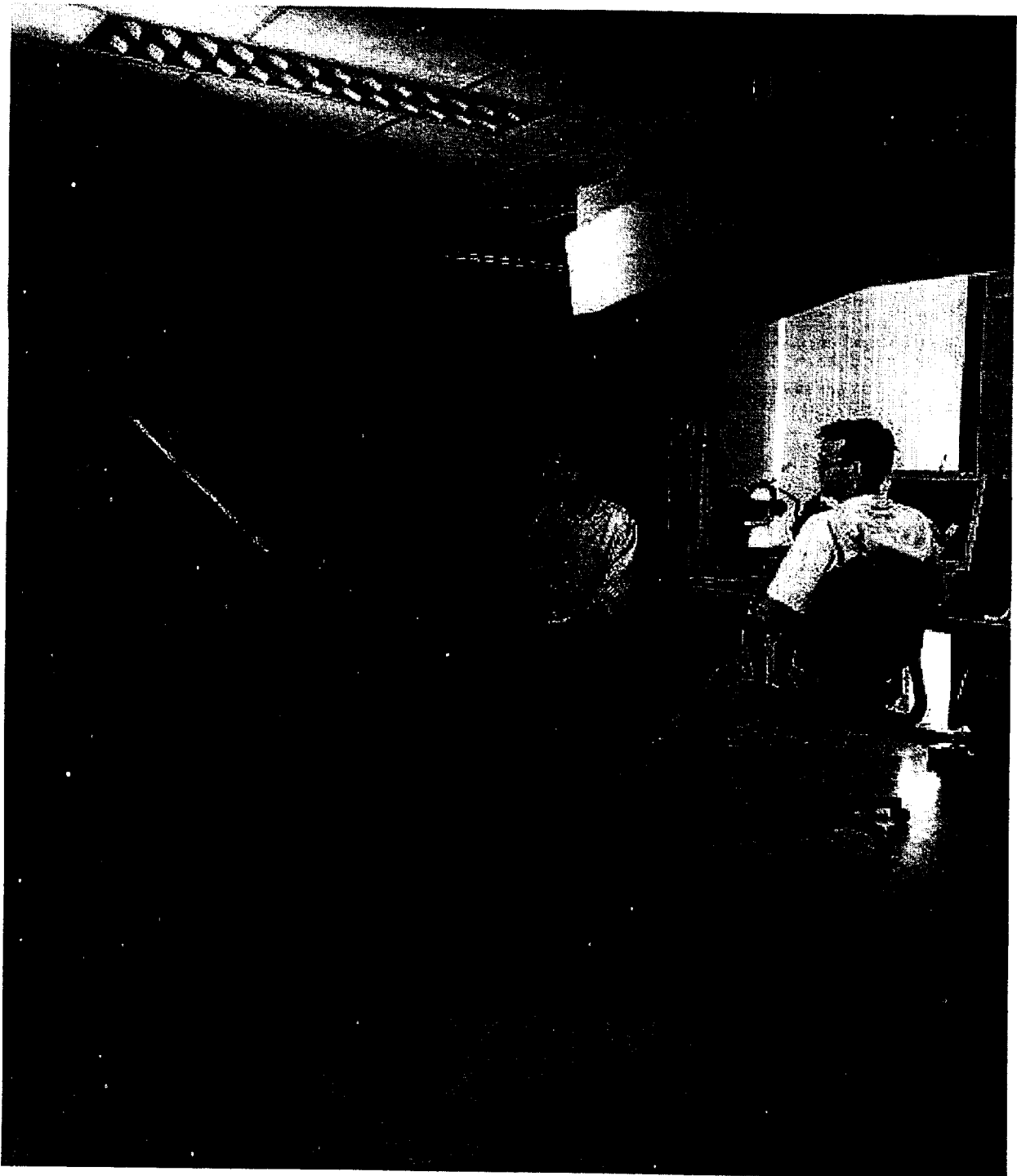

Status and Planning

- **System Requirements & Architectural Design finalized**
- **Hardware & software platforms, tools, packages procured in parallel**
- **Detailed design (and prototype coding) started June '98**
- **Initial "Pre-Flight" delivery mid '99**
- **Final delivery end '99**

EXPANDING GLOBAL ACCESS TO CIVILIAN AND COMMERCIAL REMOTE
SENSING SYSTEMS AND DATA: IMPLICATIONS AND POLICY ISSUES

G.J. Tahu
Stafford Group
Arlington, Virginia

J.C. Baker
Space Policy Institute
George Washington University
Washington, DC

K.M. O'Connell
RAND Corporation
Washington, DC

Abstract

Current and planned developments in the field of civilian and commercial¹ satellite imagery promise a major expansion in international accessibility to remote sensing data and technologies. This paper addresses the implications of the expanding global access to land remote sensing data and their derived products. While atmospheric, meteorological, and oceanographic data is also widely available at cost or free of charge, it is land remote sensing—specifically the unique systems with high-resolution and frequent revisit times—that are of primary concern for international and regional security issues. Military and intelligence satellites are not addressed in this discussion of expansion due to their inherently controlled access, unless such systems also provide commercially available imagery or products (as is the case with some Russian systems).

Introduction

Space-based imaging systems have a variety of civil and commercial applications, and Earth observation is increasingly recognized as a valuable decision-making and analysis tool for industries and governments alike. Remote sensing data and their derived products have become critical elements in weather forecasting, management of natural resources, mapping of terrain and public infrastructure, and monitoring of the global ecology. In addition to enabling applications that were previously impossible or impractical by other means, satellite-derived geospatial information products promise both time and cost savings over older or more conventional methods.¹ Several space-faring powers—including the United States,

Russia, Canada, Europe, Japan, and India—have developed substantial remote sensing capabilities to take advantage of these applications, and many emerging space-capable nations rank remote sensing as a top priority next to telecommunications as important for national economic development

Technological advances are increasingly making commercial remote sensing services a viable and lucrative business. Whereas remote sensing once depended on mainframe computers and highly trained experts, now these capabilities are available in desktop computers at relatively affordable cost. The development of advanced software and data processing techniques, as well as the advent of CD-ROM and the Internet, now allow companies to process and distribute data with relative ease. Several commercial ventures are developing privately-funded Earth observation systems to provide data and products for the growing market of remote sensing data users, with several systems expected to go into orbit within the year and more slated towards the turn of the century. Assuming these systems develop as planned, any state, organization, or individual will have relatively easy access to high-resolution geospatial information products. The growing accessibility to high-resolution^{*} satellite imagery data is also spurred by several other recent developments, including the declassification of American and Russian spy satellite imagery archives, technological advances in imaging satellites and geographical information systems (GIS), and the emergence of higher-resolution civil remote sensing systems manufactured and operated by the United States, Russia, France, and India that are already supplying imagery data to the international market.

The rapid expansion in global accessibility to remote sensing technologies and data has broad international security implications. At the same time, these new remote sensing technologies offer an important capability that can be used for socio-economic development and to support both peace negotiations and humanitarian operations. Difficult policy issues exist regarding how much national and multinational control should be exerted over commercial remote sensing operations in peacetime or during crises and armed conflicts.

*Copyright © 1997 by George J. Tahu, John C. Baker, and Kevin M. O'Connell. This paper represents the views of its authors, not necessarily those of their employers or sponsoring organizations.

¹ The term "civil" will be used to refer to non-military systems developed or operated by state governments, while "commercial" will generally refer to privately-funded and operated remote sensing systems.

But given that much of today's remote sensing technology also has a heritage of supporting military reconnaissance and defense planning, and given the importance that space-based information products proved during the 1991 Gulf Conflict, it is important to consider the security impacts that expanding access to Earth imaging technology will bring.ⁱⁱ The capabilities of current and future commercially available imaging systems can also be used for military applications as well as for civil and scientific ones.

Development of Land Remote Sensing

Satellite-based land remote sensing originated as the product of multi-billion dollar intelligence systems built and operated by the U.S. and Soviet superpowers. In the early 1960s, the U.S. experience with the TIROS meteorological satellites and the classified Corona spy-satellites demonstrated the value and feasibility of using satellite observations of the Earth for both scientific and applied purposes.ⁱⁱⁱ However, the relatively high cost and technical complexity of such early satellite systems required government-supported programs to develop and operate them. Early remote sensing platforms provided opportunities for scientific experimentation in both satellite technology and applications. The infancy of the technology and the focus on science meant that applications beyond narrow operational requirements were developed gradually over time.

Landsat

Based on its experience with weather satellites, lunar probes, and the Nimbus remote sensing research satellite, the U.S. National Aeronautics and Space Administration (NASA) began to develop a satellite that would routinely provide multispectral imagery of the Earth to detect natural resources; the resulting Earth Resources Technology Satellite (ERTS), retroactively renamed Landsat, paved the way for development of civil land remote sensing. The next generation spacecraft, Landsat 4, was dedicated to civil land remote sensing use. "These programs developed the know-how for applying satellite remote sensing data to support decision-making and analysis. Wide dissemination of early imagery helped build a cadre of data users, experienced in analyzing and applying remotely sensed data."^{iv}

SPOT

In 1978, the French space agency Centre Nationale d'Etudes Spatiales (CNES) began planning the *Satellite Pour Observation de la Terre* (SPOT) remote sensing satellite system. French planners envisioned SPOT as a government-developed, commercially-operated system, with the intent to capture a percentage of the nascent remote sensing market. "This commercial stance led SPOT planners to design the system around operational, rather than scientific, considerations, resulting in higher resolution and faster revisit time. SPOT Image², the system's marketing arm, helped develop the overall data market by aggressive salesmanship and by demonstrating useful applications, thus setting the stage for future innovation."^v Since the launch of SPOT-1 in 1986, SPOT Image has offered 10 meter resolution panchromatic imagery with wide field of view—a feature that has been one of its main selling points.

Setbacks

Not all developments in the remote sensing field have facilitated the use of satellite imagery data. For example, several of the planned remote sensing satellites have suffered from major breakdowns. The failure of Landsat 6 to reach orbit in October 1993 created a gap in the U.S. remote sensing program that should be finally closed in 1999 providing that Landsat 7 is successfully placed into orbit. More recently there has been a spate of spacecraft failures and losses. These include the launch failure of Russia's SPIN-2 (1996), and the in-orbit failures of France's SPOT-3 (1996), Japan's ADEOS (1997), NASA's Lewis satellite (1997) which was being used to test a new hyperspectral imager, and most recently, EarthWatch's EarlyBird 1 (1997).

Along with such occasional technical failures to key observation satellites, the growth of the remote sensing market continues to be constrained by the relatively high cost of acquiring timely imagery data and, in some cases, the complexity of using data retrieval and tasking systems.

² SPOT Image purchased the rights to sell SPOT imagery from the French government and CNES.

The New Environment

In spite of programmatic and operational setbacks, programs such as Landsat and SPOT helped form the foundation upon which the necessary technology, infrastructure, and experience could be developed to enable applications for remote sensing data and the development of a commercial market for satellite data and derived products. At the same time, external factors independent of remote sensing helped generate an environment more conducive to a commercial market.

The end of the Cold War both reduced international fears of allowing wider access to national remote sensing systems and opened up the possibility for world access to imagery from the former Soviet Union. Russia inherited the substantial Soviet capabilities in remote sensing; in the late 1980s, Soyuzkarta and SovInform Sputnik were established to market data from a variety of film-return systems. Over the past several years, multiple marketing and distribution arrangements have been made between Russian satellite operators and Western distributors (such as Aerial Images' SPIN-2 project), resulting in unprecedented access to Russian imagery.^{vi} In addition, Russia has begun to offer declassified imagery from military satellite systems. The United States made a similar move with its declassification of CORONA satellite imagery in 1995. This resulted in some 800,000 photographs that were taken between 1960 to 1972 being released.^{vii}

National Civil Remote Sensing Systems

The early 1990s also saw the emergence of several civil remote sensing systems launched by some of the newest space powers. The European Community's two European Remote Sensing (ERS) satellites, launched in 1991 and 1995, provide synthetic aperture radar (SAR) imagery which is distributed through Eurimage and Space Imaging. The Japanese Earth Resources Satellite (JERS-1), launched in 1992, also provides SAR imagery marketed by Japan's Remote Sensing Technology Center (RESTEC) and Space Imaging. Japan's 1995 Advanced Earth Observation System (ADEOS) briefly provided panchromatic imagery until its recent failure. Canada also fielded a SAR system in 1995 with its Radarsat satellite.

In the late 1980s and early 1990s, India inaugurated one of the most competitive systems to come on line with its Indian Remote Sensing (IRS) satellite series. India's long-term strategy is to build a national remote sensing capability for socio-economic development and ecological monitoring.^{viii} Antrix Corporation, the marketing arm for the Indian Space Research Organization (ISRO), and its U.S. distributor Space Imaging offer imagery and data products from the IRS-1A, IRS-1B, IRS-P2, IRS-1C and IRS-1D satellites.

Table 1: Existing Systems

Current Civilian & Commercial Remote Sensing Systems					
Country	Satellite	Sen.	Res.	Time	Avail.
USA	Landsat	MS	30 m	2-3 weeks	1972
USA	TIROS	MS	1 km	1-2 weeks	1960
France	SPOT	PC	10 m	2-3 weeks	1986
		MS	20 m		
Russia	Resurs-O	PC	1 m	Near real-time	1988
		PC	2 m		
		MS	4 m		
Russia	Resurs-F/Kosmos ³ KFA-3000 ⁴ DD-5 ⁵ KVR-1000 KFA-1000 MK-4 TK-350 KATE-200			2 weeks to 6 mos.	1991
		PC	2 m		
		PC	2 m		
		PC	2-3 m		
		PC	5-8 m		
		MS	5-8 m		
		PC	10 m		
Russia	Mir/Priroda & Salyut 6,7 MKF-6MA KAP-350 KFA-1000 MK-4			2 weeks to 6 mos.	1991
		MS	25 m		
		Topo	30-40 m		
		PC	2-3 m		
		MS	5-8 m		
Russia	Almaz-1	SAR	15 m	Archive	Archive
EU	ERS-1 & 2	SAR	30 m		1991
India	IRS series	PC	5.8 m		1991
		MS	23.5 m		
Japan		SAR		2-3 weeks	
Japan		PC		Archive	
Canada		SAR	⁶		1995

³ Russia launched the final Resurs-F2 #10

capsule landed on October 26, 1995. spacecraft designated "flown by Russia.

Current Russian government restrictions prevent meters. The KFA-3000 is reportedly capable of .75 2 meters for distribution.

DD-5 (which stands for digital data) is a generic DD-5 system provides 2 meter resolution images camera characteristics are withheld, so data are georeferenced form and sold

Increasingly, any state, organization, or individual can purchase high-resolution commercial imagery through private/commercial distributors and national/civil satellite organizations. In addition, France, Canada, Israel, Japan, and India are expected to be operating high-resolution remote sensing systems with both high-resolution (1-5 meters) and rapid revisit time (1-2 days) over the next decade.^{ix}

Emerging Commercial Systems

A variety of privately-funded remote sensing satellites are expected to be launched within the year. Several more commercial satellites are expected to launch in the next five years, with still more system designs in the development and proposal stages. Three U.S. companies are leading the high-resolution commercial imagery market and are expected to be the first to launch commercial satellite systems.

Space Imaging, the main distributor of Landsat and IRS imagery, is scheduled to launch its own IKONOS 1 in 1998 and IKONOS 2 about six months later. The satellites will provide 1 meter panchromatic and 4 meter resolution imagery along with a merged multi-color scene. The company also has an agreement with Antrix Corp. Ltd. of India for exclusive distribution rights of IRS data outside of India.

EarthWatch, Inc.'s launch plans for future EarlyBird and QuickBird satellites are somewhat uncertain following the on-orbit failure of EarlyBird 1 after its launch in December 1997. EarlyBird was to have offered 3 meter panchromatic and 15 meter multispectral imagery. Despite its initial setback, EarthWatch plans to proceed with launching QuickBird in 1999, which will offer 0.82 meter panchromatic and 3.28 meter multispectral imagery. EarthWatch seeks to become a leading provider of geographic data products including high-resolution satellite imagery, image maps, digital terrain models, and digital maps.

Orbital Sciences' subsidiary, Orbital Imaging Corporation (Orbimage), is currently operating two satellites: the atmospheric satellite

⁶ Radarsat's synthetic aperture radar operates in a variety of modes, producing imagery scenes ranging from 100 to approximately 8 meters in resolution.

Orbview-1 (Microlab) and the ocean color satellite Orbview-2 (SeaStar). Orbview-3, a third satellite expected to launch in 1999, will provide 1 to 2 meter panchromatic and 4 meter multispectral imagery for commercial sale. In addition, the subsequent Orbview-4 will include a U.S. government funded hyperspectral sensor providing 8 meter resolution imagery which Orbimage also expects to market.

A handful of other commercial systems—including Landsat 7, the agricultural satellites Resource-21, the China/Brazil Earth Resources Satellite (CBERS), Japan's Advanced Land Observation Satellite (ALOS), the joint Israel Aircraft Industry and Core Software Technologies' EROS series, and France's new SPOT-5 and next generation 3S satellites—promise to round out the selection of commercially available remote sensing imagery.

Table 2: Future Systems

Future Remote Sensing Systems					
Country	Satellite	Sen.	Res.	Time	Avail.
USA	Landsat 7	PC	15 m	5-7 days	1999
		MS	30 m		
USA	EarthWatch "QuickBird"	PC	.82 m	2-3 days	1998
		MS	3.28 m		
USA	Space Imaging "IKONOS 1 & 2"	PC	1 m	3-5 days	1998/99
		MS	4 m		
USA	ORBIMAGE "Orbview-3"	PC	1 m	0-3 days or Real time	1999
		PC	2 m		
		MS	4 m		
		HS	8 m		
USA	Resource 21	MS	10 m	<24 hours	1999
USA	RDL "Radar 1"	SAR	1 m	N/A	late 2001
Canada	Radarsat 2	SAR	3 m	2-7 days	2001
France	SPOT-5	PC	5 m	N/A	2002
		MS	20 m		
France	Spot Image 3S	PC	2.5 m	N/A	2003
Brazil/China	CBERS	MS	19 m	N/A	N/A
Japan	ALOS	PC	2.5 m	N/A	2000
Israel/US	West Indian Space* EROS 1 & 2	PC	1.5 m	N/A	1999

* West Indian Space, a joint venture by Israel Aircraft Industries and the U.S. company Core Software Technology, will launch and operate a constellation of high resolution imaging satellites based on the Israeli Ofeq-3 design.

The commercial market for space-based imagery is small but growing. Developments in communications, computing, and geographic information systems are creating increased prospects for the use of space-based imagery in applications ranging from urban planning and

⁷ French government and industry officials announced plans to use a technique to achieve 2.5 meter resolution imagery by blending two 5-meter resolution SPOT 5 images during processing.

resource management to tourism and gaming. At the same time, as high-resolution imagery becomes commercially available, almost anyone willing to pay will have access to imagery good enough to identify several security-related items and activities at speeds and resolutions that were previously unavailable.^x

Table 3: Minimum resolution necessary for analysis of selected items of military interest.⁸

(Resolutions in bold type would be available from commercial systems due to be launched in the next five years.)

Target	Detection [†]	General ID [†]	Precise ID [†]	Description [§]
Terrain	90+	30-90	4.5	1.5
Urban Areas	60	30	3-5	1
Ports	30	15	6	3
Rail yards	15-30	15	6	1.5
Roads	10-20	5	1	0.6
Bridges	6	4.5	1.5	1
Airfields	6	4.5	3	0.3
Nuclear reactor	5	2.5	1	0.5
Aircraft	4.5	1.5	1	0.15
Radar/radio sites	3	1-1.5	0.3	0.15
Missile sites	3	1.5	0.6	0.3
Supply depots	1.5-3	0.6	0.3	0.03
Artillery	1	0.6	0.15	0.05

* Location of a class of units, object or activity of military interest

† Determination of general target type

‡ Discrimination within target type of known types

§ Size/dimension, configuration/layout, construction, count, etc.

What Is Driving the Growing Global Accessibility?

Access to land remote sensing has steadily expanded over the past 25 years since the launch of Landsat. A confluence of factors have contributed to the accelerating growth in global accessibility to remote sensing capabilities and products. They include: (1) the internationalization of remote sensing capabilities; (2) the commercialization of satellite remote sensing programs, particularly in the United States; and (3) the multinationalization of remote sensing enterprises.

Internationalization of Remote Sensing Capabilities

⁸ Table adapted from Dunn & Robertson, subsequently developed from Ann Florini, "The Opening Skies: Third-Party Imaging Satellites and U.S. Security," *International Security*, Vol. 13, No. 2 (Fall 1988), p. 98.

The superpowers initially were the only countries that possessed the technical expertise and financial resources required to develop and operate their own observation satellites. Building upon substantial investments in military and civilian space programs during the Cold War years, the American and Soviet remote sensing programs were bolstered by the already existing technical expertise, organizational structures, and industrial infrastructures. The spread of remote sensing satellites was strongly discouraged at the time by both the substantial financial costs and major technical and operational hurdles that other countries faced in acquiring imaging satellite systems. Thus, until the mid-1980s other countries had no alternative to relying on aerial photography, depending on the superpowers as the sole source for satellite imagery data, or simply going without Earth observation data.

As noted in Table 2, the number of countries possessing their own civilian observation satellite for land remote sensing has steadily increased over time as several countries acquired the necessary technical knowledge and manufacturing capabilities, as well as decided to undertake the substantial expenditures required for acquiring a remote sensing system.^{xi} They had multiple reasons for seeking an indigenous remote sensing capability: the goal of gaining greater autonomy from foreign sources of remote sensing data, a requirement for national resource management, an interest in scientific research and developing their national technical base, a desire for greater international prestige, and an economic interest in exploiting new opportunities in the commercial space market.

The diffusion of remote sensing technology has also been accelerated by the proactive effort of the leading providers of satellite imagery to expand both the domestic and international user communities for their particular imagery data. The remote sensing capabilities and expertise of more than a dozen countries have been stimulated by the creation of a global network of ground receiving stations along with various international training activities associated with the Landsat, SPOT, ERS, and Radarsat programs. Such outreach efforts have accelerated the spread of expertise in image processing and data analysis for a broad range of scientific projects and practical applications. Thus, several countries have acquired the essential ground

infrastructure for satellite remote sensing, along with expertise in handling and analyzing imagery data, without having to possess their own civilian observation satellites. Some prominent examples include Australia, Norway, Singapore, South Africa, and the United Kingdom.

Commercialization of Remote Sensing Programs

Over the past 25 years only national governments have had the financial resources and technical capabilities necessary for developing, launching and operating various types of Earth observation satellites. Commercial firms, which were largely confined to a supporting role in national remote sensing programs, mainly focused on performing manufacturing functions or providing data archiving and marketing services. However, a new trend is emerging whereby several commercial firms are now poised to create their own remote sensing systems including imaging satellites, the needed ground infrastructure, and sophisticated data distribution networks.

A major catalyst for the commercialization of remote sensing has been the perception that a robust market exists for higher resolution imagery data and associated products as an embedded element of the information revolution.^{xii} The steady growth in computing power and data transmission systems, such as the Internet, along with the advent of more user-friendly software for image processing and analysis, has diminished many of the barriers that once limited the use of remote sensing data to large government organizations and corporations.

The development of CD-ROM disks for data storage and multimedia presentations have made remote sensing data more accessible to a wider customer base and made it possible to distribute land remote sensing data with considerable ease. Internet and database software has enabled imagery providers to use net-based marketing to support searchable archives and transfer large data files quickly and efficiently by electronic means, thereby vastly improving the timeliness of data delivery.^{xiii} Virtually all remote sensing satellite operators have a World Wide Web site devoted to marketing and, in many cases, distributing commercially available imagery. In addition, many operators have entered into licensing arrangements with multiple companies which provide Internet distribution of imagery

(such as SPIN-2's TerraServer) as well as value-added products.

One of the most significant enablers of the commercial remote sensing data market is the innovation of geographic information system (GIS) software. GIS allows users of spatial data to integrate layers of information and to manipulate them with relative ease. The rapid growth of valued-added firms with expertise in GIS has convinced some industry observers that the satellite remote sensing field is on the verge of a take-off stage. Proponents of this perspective hold that modern remote sensing satellites, which can rapidly generate large amounts of digital data over most areas of the world, are very responsive to the data requirements of advanced information systems.

Commercialization began taking on greater importance in the mid-1980s given limits on government spending and the perception that a nascent market exists for remote sensing data driven mostly by applications in urban planning, mineral exploration, and agricultural monitoring. An effort by the Reagan administration to privatize Landsat, which had originated as an experimental program with a strong scientific focus, did not succeed even though one result was to create the Earth Observation Satellite Company (EOSAT) with a mandate to operate the Landsat system and to market the resulting imagery data.^{xiv} In comparison, the French SPOT system was developed with commercial applications in mind and operated on a commercial marketing basis. SPOT eventually gained the prominent share in the growing market for land remote sensing data. Other national observation satellite systems, including the Canadian Radarsat, are placing more emphasis on developing a commercial market for their various radar data products and applications.

The commercialization trend was greatly accelerated by the Clinton administration's 1994 policy decision to loosen the long-standing restrictions on American commercial firms on developing their own remote sensing systems and selling imagery data to foreign customers. The end of the Cold War created a combination of imperatives and opportunities for reassessing U.S. policy on commercial satellite imagery. Declining defense spending prompted the concern of some in government and business that American industrial expertise in manufacturing imaging satellite systems would steadily erode unless Cold War restrictions on

commercial enterprises were relaxed. At the same time, several U.S. firms were eager to create commercial remote sensing enterprises that could take advantage of the projected market for higher resolution satellite imagery data. Furthermore, proponents of loosening government restrictions argued that other countries, such as Russia and France, would sell higher resolution satellite imagery around the world even if U.S. guidelines prohibited American firms from engaging in similar activities.

Thus, the post-Cold War era galvanized domestic pressures for changing U.S. policy to assist American firms in being highly competitive in the projected international marketplace for higher resolution imagery data, value-added services, and remote sensing technologies. The resulting policy change took the form of Presidential Decision Directive 23 (PDD-23), which President Clinton approved in March 1994. It sets forth the licensing requirements for U.S. firms interested in developing and operating private remote sensing systems. It also stipulates the government conditions that these firms must accept to receive approval for undertaking foreign sales of imagery data, sensitive technologies, or even complete turn-key observation satellite systems.

The new U.S. policy resulted from a protracted debate that involved striking a balance between the desire of many within the Clinton administration and the Congress to promote U.S. remote sensing exports while at the same time addressing legitimate concerns over the security implications of making these dual use technologies and data products available on a global basis.^{xv} While PDD-23 strikes an uneasy balance between somewhat competing security and trade objectives, the new policy does eliminate earlier impediments that were inhibiting American firms from vigorously pursuing commercial observation satellite systems. As noted in Table 2, the result is that several U.S. firms are proceeding with plans to launch observation satellites capable of producing higher resolution imagery data, as well as sophisticated networks for image processing and data distribution. Most of these firms are interested in developing new markets and applications for their imagery data. Hence, this evolution in U.S. commercial remote sensing policy will reinforce the trend toward global accessibility to Earth observation data.

Multinationalization of Remote Sensing Enterprises

Compared with Landsat and SPOT, which originated as national programs, the new remote sensing programs possess an increasingly multinational character at least in some aspects of their diverse operations. In recent years there has been a growing number of multinational relationships in manufacturing and marketing the new civilian and commercial observation satellites. These relationships run the gamut in terms of combinations of government and commercial organizations. The following are representative of the growing trend toward multinationalization:

Joint ventures and international contracts

- Chinese-Brazilian Earth Resources Satellite (CBERS)
- Israel Aircraft Industries (IAI) and Core Software Technologies (U.S.) to develop the Earth Resources Observation System (EROS)
- U.S. Air Force contract to France's Matra CAP Systems to build a mobile receiving and processing station for SPOT and other types of civilian imagery

Equity investors and strategic alliances

- EarthWatch (U.S. commercial firm) with equity investments from Hitachi, Ltd. (Japan), Nuova Telespazio (Italy), and MacDonald, Dettwiler and Associates (Canada)
- Space Imaging (U.S. commercial firm) with equity investments from Mitsubishi Corp. (Japan), Van Der Horst Ltd. (Singapore), and Space Imaging Europe (Greece).

Data distribution relationships

- Russian civilian remote sensing providers contract with Western imagery data distributors such as Jebco Information Services (England), Core Software (U.S.) and Satellitbild (Sweden) to help market their imagery data.
- Space Imaging contracts with foreign governments to market their imagery data (e.g., India's IRS series, Canada's Radarsat, and Japan's JERS)

These examples highlight the diverse nature of multinational relationships in the remote sensing area. They not only include government-

to-government and commercial joint ventures, but also business relationships between governments and foreign commercial firms. They are being driven by two basic features of the new environment for remote sensing operations: limited resources and a desire for global distribution networks. The substantial capital and operating costs associated with acquiring and operating modern remote sensing systems creates an imperative to seek collaborators and equity investors. Both government organizations and commercial enterprises are increasingly receptive to having international partners in today's tight budgetary environment. The second factor involves the desire for global data distribution networks. This has encouraged some government remote sensing providers, such as Russia, Canada, and India, to establish foreign commercial relationships with the hope of bolstering their imagery data sales abroad. In addition, the new commercial remote sensing enterprises are giving priority in their business plans to developing strategic alliances with foreign firms. Their plans call for these foreign affiliates to play major roles in key operations ranging from sensor tasking and data reception to distributing and archiving their imagery data.^{xvi} This multinationalization trend is likely to continue to grow, particularly for commercial remote sensing enterprises, over the next few years.

Implications

The nature of remote sensing from space has changed considerably over the past 25 years. This changed remote sensing environment is likely to pose new challenges for national governments and international organizations in encouraging the productive and cooperative use of Earth observation data. Three key issues that policy makers and analysts must consider are:

1. the dual-use aspects of higher resolution satellite imagery,
2. the uncertain remote sensing market, and
3. the need to renovate existing international institutions for governing remote sensing activities.

The Dual-Use Problem

The dual-use potential of Earth observation data is significantly increasing as new civilian and commercial observation satellites begin to acquire characteristics that were once associated

only with imaging satellites used for military and intelligence collection purposes.^{xvii} However, growing global access to remote sensing data and technologies also could be used to encourage regional conflict resolution and support peace negotiations.

The Gulf War in 1991 highlighted the growing importance of satellite systems, including civilian observation satellites. During the crisis and the subsequent conflict Iraq was denied access to Landsat and SPOT imagery while the Coalition countries used these same imagery sources to update military maps and support mission planning. The experience of the Gulf War was not lost on other nations and several countries are now seeking to acquire their own observation satellite systems. Furthermore, intelligence services and military organizations worldwide are expected to become major customers for the imagery data products from many of the new commercial remote sensing enterprises.

Compared with what was available during the Gulf War, the new generation of commercial and civilian satellites will offer imagery data of potentially greater military utility. The new remote sensing systems will not only provide imagery data of higher spatial resolution (i.e., 1 to 5 meters compared with Landsat's 30 meter and SPOT's 10 meter resolution), but also offer major improvements in revisit times, geo-location accuracy, and in some cases, the ability to produce stereo imaging. In addition, radar imaging and hyperspectral sensors will be available as civilian and commercial remote sensing systems.

Nonetheless, despite their improvements, commercial and civilian observation satellite systems have some important limitations compared with dedicated military satellites for supporting military planners. Combat operations often place a premium on obtaining assured and timely access to imagery data while civilian remote sensing operations usually forego such demanding and expensive capabilities. Thus, even though the new commercial imagery data can probably be used to support military mapping, force monitoring, and even targeting of another country's military facilities in peacetime, making timely use of such data in a wartime situation would be a much more problematical task when depending only on commercial or civilian sources of imagery data.

Besides their potential military utility, the new remote sensing technologies and imagery data offer an important capability that can be used to support peace negotiations and efforts to improve regional stability. Commercial satellite imagery and improved image processing systems played an important role in helping the negotiators in the Dayton peace negotiations to resolve complicated territorial issues, which needed to be settled before the peace agreement regarding Bosnia could be realized.^{xviii} In addition, improved civilian and commercial observation satellites can potentially offer new means to promote regional stability. For example, more timely and higher resolution imagery data could be used in potential flashpoint regions, such as the Spratly Islands in the South China Sea or disputes in South Asia. Improved remote sensing capabilities offer regional governments and even non-government organizations a new means for helping to mitigate regional disputes through increased transparency. They also provide a basis for developing confidence-building measures based on data that will be available to all parties involved in the dispute.

The dual-use character of the new civilian and commercial imagery data has already raised difficult questions regarding whether some form of multilateral constraints should be placed on the new remote sensing operations. For example, concerns over the impact on higher resolution imagery (i.e., 1 to 2 meters resolution) on Israel's security situation led the U.S. government to agree that American commercial firms would not collect and distribute higher resolution imagery of Israeli territory.^{xix} The idea of such "blackout" zones, however, conflicts with the fundamental principle of "open skies" that has been an international norm for Earth observation activities. Thus, the trend toward increasingly higher resolution imagery data collected from space-based sensors is also posing some new challenges for policy makers.

Uncertainty of the Commercial Market

One feature around which global access to remote sensing data hinges is the extent to which a viable commercial market develops. While there is considerable discussion about emerging capabilities—stimulated mostly by the companies involved—there is a recognition on the part of all concerned that the commercial market for high-resolution commercial imagery from space is a

market that must be created, sustained, and grown. Market growth and expansion must take place relatively quickly, however, due to the significant costs associated with building and flying satellites and related activities. Yet in considering the commercial market, it is important to clarify one's terms and understanding of this market quite precisely, and avoid the understandable hype that surrounds a new industry.

First of all, it is important to distinguish between the market for data and the market for value-added information. While the market for data—raw images—is likely confined to the scientific and perhaps security communities, it is the market for information based on those images that has the greatest potential and the greatest number of potential applications. Revenue forecasts for this processed data range as high as \$20 billion (although the analytical basis for these forecasts is uncertain).

Second, as application development proceeds, what can and cannot be done with the planned commercial data must be weighed. Notions of stopping crime on the streets or human rights violations in progress, while admirable and well intended, are inconsistent with the quality and the accessibility to the information by potential users. Moreover, within the security domain, while 1 meter satellite information is of potentially important use to a military entity, its value is limited, and certainly bound by other features of military decision-making, technology, and organization.

The extent to which the commercial market expands also depends on some key assumptions. While the emerging group of commercial providers is pursuing diverse strategies in terms of their costs, distribution systems, and the market segments to pursue, they are making assumptions about displacing the airborne photography market, parallel applications development, and market growth that may be too optimistic or even incorrect.^{xx} Other issues related to financing, insurance, marketing, and space-specific concerns like orbital slots and spares also create uncertainty about the expansion potential and rate of this market.

Most importantly, however, is the role that governments will continue to play in affecting the commercial market. Remote sensing is still an

arena dominated by governments, which have reasons other than economic incentives and constraints that drive their involvement in the market. Despite the U.S. market expectations that led to the 1994 decision to allow industry to sell remote sensing data and technology, for example, the full policy and regulatory regime to allow development of this market has not yet been developed. Concerns about the extent to which market considerations will intersect with national and international security considerations are yet to be determined, representing a de facto barrier to foreign investment and commitments to commercial sales.

New Challenges for the International Community

The emerging environment for remote sensing features some important departures from the international experience in remote sensing from space that has been associated with the Landsat and SPOT programs. None of these changes is more dramatic than the rapid growth in global accessibility to Earth observation technologies and data. As discussed in this paper, some key trends include:

- Growing numbers of land remote sensing systems with varied sensor capabilities,
- Transition from purely national programs to multinational and commercial remote sensing enterprises, and
- Expanding range of applications and users for remote sensing data.

National policy makers and international specialists face greater complexity and more uncertainties in trying to manage the emerging remote sensing environment. This new situation raises an important question: are the national policies and international institutions that were developed for the time of Landsat and SPOT still adequate for the task of encouraging international coordination and do they require renovation or even reconsideration? The changing context for remote sensing suggests that policy makers will confront new challenges associated with greatly expanded remote sensing capabilities, complex data distribution networks, and new types of users. This situation portends new opportunities for international cooperation, particularly in

environmental monitoring and disaster warning and humanitarian relief operations. On the other hand, the dual-use nature of the new commercial and civilian imagery data raises difficult questions regarding whether and how national governments and international institutions should consider setting limits on the use of civilian and commercial remote sensing operations.⁹ These questions are particularly pertinent in situations, such as regional crises or military conflicts, where the higher resolution imagery data could play either a positive or negative role depending on when and how the data become available to the regional adversaries.

Whether we are prepared or not, a rapid change in the nature of the civilian and commercial remote sensing is currently underway. The new observation satellite systems that are beginning to become available over the next few years promise to pose important policy issues for both national governments and international organizations. The challenge is for policy makers and analysts to recognize and seize the opportunities for international collaboration while adopting policies and practices that hedge against the potentially harmful uses of the new remote sensing systems.

⁹ The primary international institutions associated with land remote sensing are the Committee on Earth Observation Satellites (CEOS) and the Earth Observation International Coordination Working Group (EO-ICWG).

References and Bibliography

- ⁱ Khuen, C., "Commercial Applications for High Resolution Geospatial Imagery," *Photogrammetric Engineering & Remote Sensing* (PE&RS), August 1997, p. 933.
- ⁱⁱ "Improvements in Commercial Satellite Imagery," *Strategic Comments*, Vol. 2, No. 10, International Institute for Strategic Studies, December 1996.
- ⁱⁱⁱ Ray A. Williamson, "The Landsat Legacy: Remote Sensing Policy and the Development of Commercial Remote Sensing," *Photogrammetric Engineering & Remote Sensing*, July 1997, p. 877-885.
- ^{iv} *Ibid*, p. 878.
- ^v *Ibid*, p. 880.
- ^{vi} George J. Tahu, "Commercial Activities in Russian Remote Sensing," ANSER Center for International Aerospace Cooperation, 1997.
- ^{vii} Robert A. McDonald, "CORONA: Success for Space Reconnaissance, A Look Into the Cold War, and a Revolution for Intelligence," PE&RS (June 1995), pp.689-720; and Dwayne A. Day, John M. Logsdon, and Brian Latell, eds. *Eye in the Sky: The Story of the CORONA Spy Satellites*, (Washington, D.C.: Smithsonian Institution Press, 1998).
- ^{viii} Waheguru Pal Singh Sidhu, *Enhancing Indo-US Strategic Cooperation*, (London: International Institute for Strategic Studies, 1997), pp. 60-68.
- ^{ix} Dunn, L. and Robertson, M., *Satellite Imagery Proliferation and the Arms Control Intelligence Process*, Science Applications International Corporation, 1997, p. 1.
- ^x *Ibid*, p. 6.
- ^{xi} U.S. Congress, Office of Technology Assessment, *The Future of Remote Sensing from Space: Civilian Satellite Systems and Applications*, OTA-ISC-558, Washington, D.C.: US Government Printing Office, July 1993.
- ^{xii} Trudy E. Bell, "Remote Sensing," *IEEE Spectrum*, March 1995, 24-31.
- ^{xiii} Williamson, p. 883.
- ^{xiv} *Ibid*, p. 878.
- ^{xv} John C. Baker, *Trading Away Security?: The Clinton Administration's 1994 Decision on Imaging Satellite Exports*, Pew Case Studies in International Affairs, Washington, D.C.: Institute for the Study of Diplomacy, Georgetown University, 1997.
- ^{xvi} *Strategic Comments*, 1996.
- ^{xvii} Vipin Gupta, "New Satellite Images for Sale," *International Security*, 20, Summer 1995, 94-125.
- ^{xviii} Joseph Anselmo, "Satellite Data Plays a Key Role in Bosnia Peace Treaty," *Aviation Week and Space Technology*, (December 11, 1995), p.29.
- ^{xix} Warren Ferster, "U.S. to Restrict Satellite Images of Israel," *SpaceNews*, (August 5 to 11, 1996), p. 3.
- ^{xx} C. Bryan Gabbard, Kevin M. O'Connell, George S. Park, and Peter J.E. Stan, *Emerging Markets of the Information Age: A Case Study in Remote Sensing Data and Technology*, (Santa Monica, CA: RAND Corp., 1996).

REPORT DOCUMENTATION PAGE			Form Approved OMB No. 0704-0188	
Public reporting burden for this collection of information is estimated to average 1 hour per response, including the time for reviewing instructions, searching existing data sources, gathering and maintaining the data needed, and completing and reviewing the collection of information. Send comments regarding this burden estimate or any other aspect of this collection of information, including suggestions for reducing this burden, to Washington Headquarters Services, Directorate for Information Operations and Reports, 1215 Jefferson Davis Highway, Suite 1204, Arlington, VA 22202-4302, and to the Office of Management and Budget, Paperwork Reduction Project (0704-0188), Washington, DC 20503.				
1. AGENCY USE ONLY (Leave blank)		2. REPORT DATE July 1998	3. REPORT TYPE AND DATES COVERED Conference Publication	
4. TITLE AND SUBTITLE Proceedings of the Seventh International Space University Alumni Conference			5. FUNDING NUMBERS WU-022-00-00-00	
6. AUTHOR(S) Sheila Bailey, editor				
7. PERFORMING ORGANIZATION NAME(S) AND ADDRESS(ES) National Aeronautics and Space Administration John H. Glenn Research Center at Lewis Field Cleveland, Ohio 44135-3191			8. PERFORMING ORGANIZATION REPORT NUMBER E-11768	
9. SPONSORING/MONITORING AGENCY NAME(S) AND ADDRESS(ES) National Aeronautics and Space Administration Washington, DC 20546-0001			10. SPONSORING/MONITORING AGENCY REPORT NUMBER NASA CP-1999-209199	
11. SUPPLEMENTARY NOTES Responsible person, Sheila Bailey, NASA Glenn Research Center, organization code 5410, (216) 433-2228.				
12a. DISTRIBUTION/AVAILABILITY STATEMENT Unclassified - Unlimited Subject Category: 99 Distribution: Standard This publication is available from the NASA Center for AeroSpace Information, (301) 621-0390.			12b. DISTRIBUTION CODE	
13. ABSTRACT (Maximum 200 words) The Seventh Alumni Conference of the International Space University, coordinated by the ISU U.S. Alumni Organization (IUSAO), was held at Cleveland State University in Cleveland, Ohio on Friday, July 24, 1998. These proceedings are a record of the presentations.				
14. SUBJECT TERMS Solar cells; Satellite; Photovoltaics; Solar arrays			15. NUMBER OF PAGES 106	
			16. PRICE CODE A06	
17. SECURITY CLASSIFICATION OF REPORT Unclassified	18. SECURITY CLASSIFICATION OF THIS PAGE Unclassified	19. SECURITY CLASSIFICATION OF ABSTRACT Unclassified	20. LIMITATION OF ABSTRACT	

