

# Modular Low-Heater-Power Cathode/Electron Gun Assembly for Microwave and Millimeter Wave Traveling Wave Tubes

A low-cost, low-mass, electrically efficient, modular cathode/electron gun assembly has been developed by FDE Inc. of Beaverton, Oregon, under a Small Business Innovation Research (SBIR) contract with the NASA Glenn Research Center at Lewis Field. This new assembly offers significant improvements in the design and manufacture of microwave and millimeter wave traveling-wave tubes (TWT's) used for radar and communications. It incorporates a novel, low-heater-power, reduced size and mass, high-performance barium-dispenser type thermionic cathode (ref. 1) and provides for easy integration of the cathode into a large variety of conventional TWT circuits. Among the applications are TWT's for Earth-orbiting communication satellites and for deep space communications, where future missions will require smaller spacecraft, higher data transfer rates (higher frequencies and radiofrequency output power), and greater electrical efficiency. A particularly important TWT application is in the microwave power module (a hybrid microwave/millimeter wave amplifier consisting of a low-noise solid-state driver, a small TWT, and an electronic power conditioner integrated into a single compact package), where electrical efficiency and thermal loading are critical factors and lower cost is needed for successful commercialization.

The design and fabrication are based on practices used in producing cathode ray tubes (CRT's), which is one of the most competitive and efficient manufacturing operations in the world today. The approach used in the design and manufacture of thermionic cathodes and electron guns for CRT's has been optimized for fully automated production, standardization of parts, and minimization of costs. It is applicable to the production of similar components for microwave tubes, with the additional benefits of low mass and significantly lower cathode heater power (less than half that of dispenser cathodes presently used in TWT's).

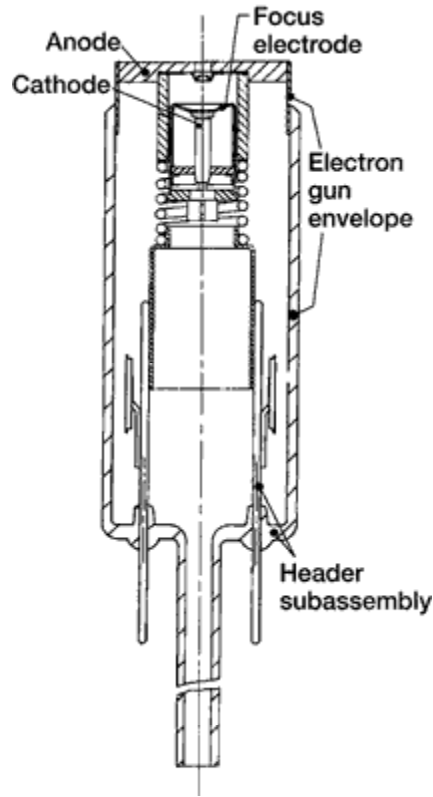

*Modular cathode/electron gun assembly.*

The modular cathode/electron gun assembly consists of four subassemblies—the cathode, the focus electrode, the header (including the electrical feedthroughs), and the gun envelope (including the anode)—a diagram of which is shown in the figure. The modular construction offers a number of significant advantages, including flexibility of design, interchangeability of parts, and a drop-in final assembly procedure for quick and accurate alignment. The gun can accommodate cathodes ranging in size from 0.050 to 0.250-in. in diameter and is applicable to TWT's over a broad range of sizes and operating parameters, requiring the substitution of only a few parts: that is, the cathode, focus electrode, and anode. The die-pressed cathode pellets can be made with either flat or concave (Pierce gun design) emitting surfaces. The gun can be either gridded (pulse operation) or ungridded (continuous operation). Important factors contributing to low cost are the greater use of CRT materials and parts, the standardization of processes (welding and mechanical capture), and tooling amenable to automated production. Examples are the use of simple shapes, drawn or stamped metal parts, and parts joined by welding or mechanical capture.

Feasibility was successfully demonstrated in the retrofit and testing of a commercial Ka-band (22-GHz) TWT. The modular cathode/electron gun assembly was computer modeled to replicate the performance of the original electron gun and fabricated largely from existing CRT parts. Significant test results included demonstration of low heater power (1.5-W, 1010 °C brightness temperature for a 0.085-in.-diameter cathode), mechanical ruggedness (100g shock and vibration tests in accordance with military specifications

(MIL specs)), and a very fast warmup. The results of these tests indicate that the low-cost CRT manufacturing approach can be used without sacrificing performance and reliability.

## References

1. Wintucky, E.G.: Novel Low-Cost, Low-Power Miniature Thermionic Cathode Developed for Microwave/Millimeter Wave Tube and Cathode Ray Tube Applications. NASA/TM—1999-208815, 1999, pp. 82–83.

**Glenn contact:** Edwin G. Wintucky, (216) 433–3510, [Edwin.G.Wintucky@grc.nasa.gov](mailto:Edwin.G.Wintucky@grc.nasa.gov)

**FDE Inc. (now e beam, inc.) contact:** Bernard K. Vancil, (503) 628–0703, [bernie@ebeaminc.com](mailto:bernie@ebeaminc.com)

**Author:** Edwin G. Wintucky

**Headquarters program office:** OSS (ATMS)

**Programs/Projects:** Space Communications