

Performance Analysis of Direct-Sequence Code-Division Multiple-Access Communications with Asymmetric Quadrature Phase-Shift-Keying Modulation

C.-W. Wang¹ and W. Stark¹

This article considers a quaternary direct-sequence code-division multiple-access (DS-CDMA) communication system with asymmetric quadrature phase-shift-keying (AQPSK) modulation for unequal error protection (UEP) capability. Both time synchronous and asynchronous cases are investigated. An expression for the probability distribution of the multiple-access interference is derived. The exact bit-error performance and the approximate performance using a Gaussian approximation and random signature sequences are evaluated by extending the techniques used for uniform quadrature phase-shift-keying (QPSK) and binary phase-shift-keying (BPSK) DS-CDMA systems. Finally, a general system model with unequal user power and the near-far problem is considered and analyzed. The results show that, for a system with UEP capability, the less protected data bits are more sensitive to the near-far effect that occurs in a multiple-access environment than are the more protected bits.

I. Introduction

In the design of a wireless communication system, feedback between the transmitter and receiver regarding the channel condition is useful for adapting the radio transmission rate to match the channel conditions [1,3–5,19]. When the channel condition is good, the data rate is increased, while when the channel condition is bad, the data rate is decreased. However, in some cases the transmitter does not know the condition of the channel and still desires to match the data rate to the channel. In this case, modulation and demodulation techniques are needed that allow more data to be transmitted when the channel is good and less when the channel is bad, without the transmitter knowing in advance the condition of the channel.

¹ University of Michigan, Department of Electrical Engineering and Computer Science (EECS), Ann Arbor, Michigan.

The research described in this publication was carried out by the Jet Propulsion Laboratory, California Institute of Technology, under a contract with the National Aeronautics and Space Administration.

Consider for example the transmission of an image. Suppose that there are two modes of operation at the receiver with respect to high and low signal-to-noise ratios (SNRs). The two modes have different demodulation and decoding strategies according to two different rates and image qualities. In the high SNR mode, the receiver can demodulate and decode the data at high rate (or full rate) and recover the image with its high quality. In the low SNR mode, the protection available with coding and modulation is not adequate to protect all the data. However, it may be possible to decode only a subset of the bits that have higher error protection. In this case, the receiver demodulates and decodes the data at a lower rate, and recovers the image with lower quality as compared to the high-quality image.

In a wireless network, the channel condition can vary for several reasons. One reason is just the change in the distance between the transmitter and the receiver. Another reason is that the multiple-access interference produces time-varying channel conditions.

The key idea in designing such a system is to introduce modulation and coding schemes that provide different error protection to different classes of data. The earlier work on multicasting [6,11–16] and unequal error protection (UEP) [8,18,20] examined such a system in the case of a mobile network downlink. This idea is essential when different portions of the source do not contribute evenly to the overall quality of the decoded information. The UEP technique is a simple and efficient method to satisfy such a requirement. The basic idea is to use a constellation with non-uniformly spaced signal points in the modulation scheme. The non-uniform nature of such a constellation results in different distances between sets of signals and provides different levels of reliability against noise and interference and, hence, unequal error protection on different bits of a symbol. An asymmetric quadrature phase-shift-keying (AQPSK) constellation can be regarded as the simplest modulation scheme to provide the system with UEP capability.

In [9], a quaternary direct-sequence code-division multiple-access (DS-CDMA) system is analyzed and an expression for the SNR is determined. However, the exact bit-error rate (BER) performance is not derived. In [7] and [17], the case of binary DS-CDMA with random signature sequences is investigated for binary phase-shift-keying (BPSK). Also, the Gaussian approximation to the interference is used to approximate the performance. In this article, we derive the exact BER for a quaternary DS-CDMA system and also derive the approximate BER using a Gaussian approximation to the interference for AQPSK. We consider a direct-sequence spread-spectrum modulation technique with asymmetric QPSK modulation that allows higher data rate transmission if the channel is good and a lower transmission rate when the channel condition is poor. We analyze the performance of a quaternary DS-CDMA communication using AQPSK modulation over an additive white Gaussian noise (AWGN) channel, with a correlation receiver that is coherent to the desired user. We look at both the cases of specific and random signature sequences being used in the system.

This article is organized as follows. In Section II, the system model is introduced. In Section III, we derive the exact BER performance of the system. This also includes the derivation of the probability density function (pdf) of the multiple-access interference (MAI). A numerical example is given to illustrate the performance using a specific set of signature sequences. In Section IV, the random signature-sequence case is considered. The Gaussian approximation is used to model the MAI, and the approximate BER performance is obtained. In Section V, we generalize the signal model and examine the near-far effect on the system performance.

II. System Model

In this section, we describe the mathematical model of an asymmetric QPSK modulation system and characterize the receiver output. We consider an extension of the model described in [9] for asynchronous quaternary DS-CDMA. The model is shown in Fig. 1. The difference from [9] is that we consider

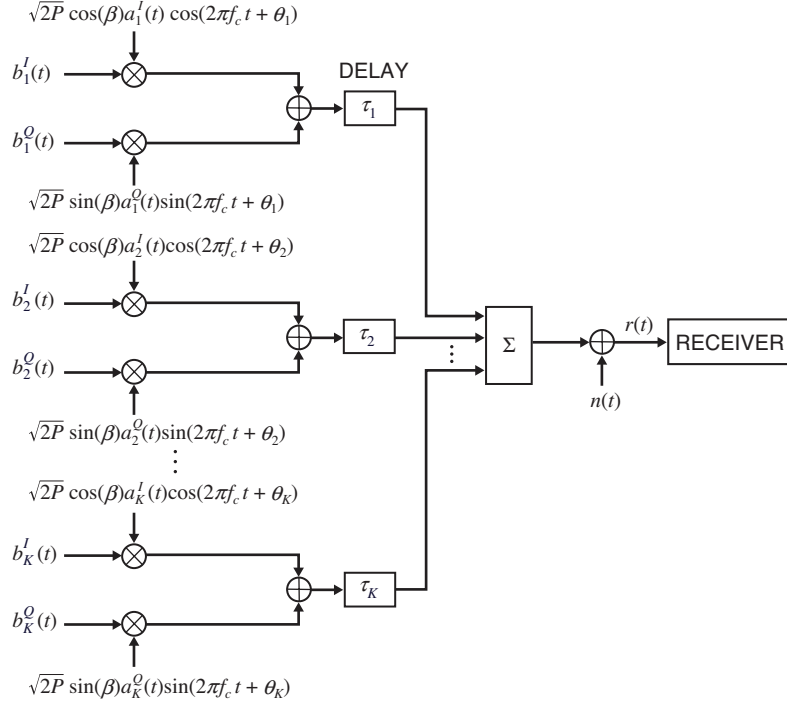

Fig. 1. A quaternary DS-CDMA communication system model.

asymmetric QPSK so that the in-phase (I)-channel and quadrature-phase (Q)-channel bits have unequal energy. Suppose there are K users in the system. The quaternary signal of the k th user is given by

$$s_k(t) = s_k^I(t) + s_k^Q(t)$$

where

$$s_k^I(t) = \sqrt{2P} \cdot \cos \beta \cdot a_k^I(t) b_k^I(t) \cos(2\pi f_c t + \theta_k)$$

$$s_k^Q(t) = \sqrt{2P} \cdot \sin \beta \cdot a_k^Q(t) b_k^Q(t) \sin(2\pi f_c t + \theta_k)$$

In the above expressions, P is the transmitted power, β is the angle of the signal points in the asymmetrical constellation, $a_k^I(t)$ and $a_k^Q(t)$ are the spreading signals of the I and Q channels, $b_k^I(t)$ and $b_k^Q(t)$ are the user information being transmitted in the I and Q channels, and θ_k is the initial phase of the k th user and is assumed to be uniformly distributed over the interval $[0, 2\pi]$. The modulation constellation is shown in Fig. 2. In this scheme, we choose $0 < \beta < \pi/4$.

The information being transmitted by user k is represented by

$$b_k^I(t) = \sum_{j=-\infty}^{\infty} b_{k,j}^I \cdot p_T(t - jT)$$

$$b_k^Q(t) = \sum_{j=-\infty}^{\infty} b_{k,j}^Q \cdot p_T(t - jT)$$

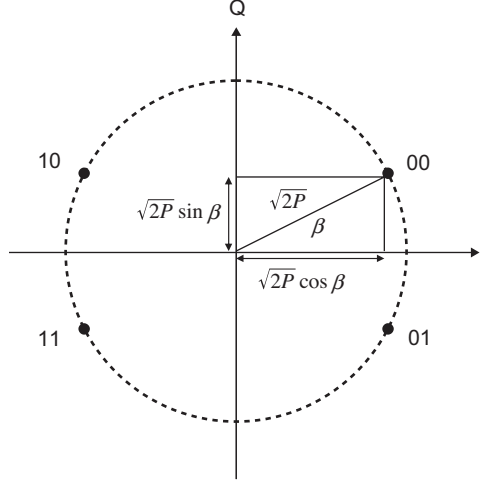

Fig. 2. Asymmetric QPSK constellation.

where $b_{k,j}^I, b_{k,j}^Q \in \{\pm 1\}$, T is the symbol duration, and

$$p_T(t) = \begin{cases} 1, & 0 \leq t \leq T \\ 0, & \text{otherwise} \end{cases}$$

The spreading signals are expressed as

$$a_k^I(t) = \sum_{j=-\infty}^{\infty} a_{k,j}^I \cdot \psi(t - jT_c)$$

$$a_k^Q(t) = \sum_{j=-\infty}^{\infty} a_{k,j}^Q \cdot \psi(t - jT_c)$$

where $a_{k,j}^I, a_{k,j}^Q \in \{\pm 1\}$ are the signature sequences for the I and Q channels, T_c is the chip duration such that $T = NT_c$, and $\psi(t)$ is the chip waveform which is nonzero for $0 \leq t \leq T_c$. In general, we can choose any pulse shape as the chip waveform. However, to simplify the analysis, in the following we will assume that the rectangular pulse is used as the chip waveform, i.e., $\psi(t) = p_{T_c}(t)$.

The receiver is assumed to consist of a simple correlator matched to the desired signal. We examine both the time synchronous and asynchronous cases. Even though the asynchronous case is the more realistic case of the two, the synchronous case is more easily analyzed than the asynchronous case. When considering channel coding using linear block codes, it is very difficult to analyze the asynchronous case due to the dependency of bit errors within one block.

A. Asynchronous System

We first consider the asynchronous case. The received signal is given by

$$\begin{aligned}
r(t) &= \sum_{k=1}^K s_k(t - \tau_k) + n(t) \\
&= \sum_{k=1}^K \sqrt{2P} \cos \beta \cdot a_k^I(t - \tau_k) b_k^I(t - \tau_k) \cos(2\pi f_c(t - \tau_k) + \theta_k) \\
&\quad + \sum_{k=1}^K \sqrt{2P} \sin \beta \cdot a_k^Q(t - \tau_k) b_k^Q(t - \tau_k) \sin(2\pi f_c(t - \tau_k) + \theta_k) + n(t) \\
&= \sum_{k=1}^K \sqrt{2P} \cos \beta \cdot a_k^I(t - \tau_k) b_k^I(t - \tau_k) \cos(2\pi f_c t + \phi_k) \\
&\quad + \sum_{k=1}^K \sqrt{2P} \sin \beta \cdot a_k^Q(t - \tau_k) b_k^Q(t - \tau_k) \sin(2\pi f_c t + \phi_k) + n(t)
\end{aligned}$$

where $n(t)$ is an additive white Gaussian noise with zero mean and two-sided power spectral density $N_0/2$. The time delay of the k th signal is represented by τ_k and $\phi_k = \theta_k - 2\pi f_c \tau_k \pmod{2\pi}$.

The analysis here basically follows the methods in [9] and [2]. Consider the output of the correlation receiver for the first user. The output of the I-channel correlator for the data bit $b_{1,0}^I$ can be decomposed into terms corresponding to the desired signal, the interference, and noise as follows:

$$\begin{aligned}
Z_1^I &= \int_0^T r(t) a_1^I(t) \cos(2\pi f_c t) dt \\
&= \int_0^T \sqrt{2P} \cos \beta \cdot a_1^I(t) b_1^I(t) \cos(2\pi f_c t) a_1^I(t) \cos(2\pi f_c t) dt \\
&\quad + \int_0^T \sqrt{2P} \sin \beta \cdot a_1^Q(t) b_1^Q(t) \sin(2\pi f_c t) a_1^I(t) \cos(2\pi f_c t) dt \\
&\quad + \sum_{k=2}^K \int_0^T \sqrt{2P} \cos \beta \cdot a_k^I(t - \tau_k) b_k^I(t - \tau_k) \cos(2\pi f_c t + \phi_k) a_1^I(t) \cos(2\pi f_c t) dt \\
&\quad + \sum_{k=2}^K \int_0^T \sqrt{2P} \sin \beta \cdot a_k^Q(t - \tau_k) b_k^Q(t - \tau_k) \sin(2\pi f_c t + \phi_k) a_1^I(t) \cos(2\pi f_c t) dt \\
&\quad + \int_0^T n(t) a_1^I(t) \cos(2\pi f_c t) dt
\end{aligned}$$

In the above expression, the component due to the desired signal is

$$\begin{aligned}
A &= \int_0^T \sqrt{2P} \cos \beta \cdot b_1^I(t) (a_1^I(t))^2 \cos^2(2\pi f_c t) dt \\
&= \sqrt{2P} \cos \beta \cdot b_{1,0}^I \int_0^T \frac{1}{2} [1 + \cos(4\pi f_c t)] dt \\
&= T \sqrt{P/2} \cos \beta \cdot b_{1,0}^I
\end{aligned}$$

where the double frequency term is negligible since we assume $f_c \gg (T_c)^{-1}$. Because of the assumption of coherent reception, the component of the I-channel correlator output due to the Q-channel signal is

$$\begin{aligned}
B &= \int_0^T \sqrt{2P} \sin \beta \cdot a_1^Q(t) b_1^Q(t) \sin(2\pi f_c t) a_1^I(t) \cos(2\pi f_c t) dt \\
&= \sqrt{2P} \sin \beta \cdot b_{1,0}^Q \int_0^T a_1^Q(t) a_1^I(t) \sin(2\pi f_c t) \cos(2\pi f_c t) dt \\
&= 0
\end{aligned}$$

The interference component of the I-channel correlator output is given by

$$\begin{aligned}
C_k &= \int_0^T \sqrt{2P} \cos \beta \cdot a_k^I(t - \tau_k) b_k^I(t - \tau_k) \cos(2\pi f_c t + \phi_k) a_1^I(t) \cos(2\pi f_c t) dt \\
&= \sqrt{2P} \cos \beta \int_0^T b_k^I(t - \tau_k) a_k^I(t - \tau_k) a_1^I(t) \cos(2\pi f_c t + \phi_k) \cos(2\pi f_c t) dt \\
&= \sqrt{2P} \cos \beta \int_0^T b_k^I(t - \tau_k) a_k^I(t - \tau_k) a_1^I(t) \frac{1}{2} [\cos(\phi_k) + \cos(4\pi f_c t + \phi_k)] dt \\
&= \sqrt{P/2} \cos \beta \cdot \cos(\phi_k) \int_0^T b_k^I(t - \tau_k) a_k^I(t - \tau_k) a_1^I(t) dt \\
&= \sqrt{P/2} \cos \beta \cdot \cos(\phi_k) [b_{k,-1}^I R_{k,1}^{II}(\tau_k) + b_{k,0}^I \widehat{R}_{k,1}^{II}(\tau_k)] \tag{1}
\end{aligned}$$

where the time cross-correlations $R_{k,i}^{II}(\tau)$ and $\widehat{R}_{k,i}^{II}(\tau)$ are defined as [9]²

² Note that the “hat” notation on the cross-correlation functions is used to denote the correlation over the complementary (with respect to the symbol duration) portion of the integration interval.

$$R_{k,i}^{II}(\tau) = \int_0^\tau a_k^I(t-\tau)a_i^I(t)dt \quad (2)$$

$$\widehat{R}_{k,i}^{II}(\tau) = \int_\tau^T a_k^I(t-\tau)a_i^I(t)dt \quad (3)$$

Letting

$$I_{k,i}^{II}(\underline{b}_k^I, \tau, \phi) = T^{-1} \left[b_{k,-1}^I R_{k,1}^{II}(\tau_k) + b_{k,0}^I \widehat{R}_{k,1}^I(\tau_k) \right] \cos \phi \quad (4)$$

then Eq. (1) can be written as

$$C_k = T\sqrt{P/2} \cos \beta \cdot I_{k,1}^{II}(\underline{b}_k^I, \tau_k, \phi_k)$$

The total I-channel interference is then

$$\sum_{k=2}^K C_k = T\sqrt{P/2} \cos \beta \sum_{k=2}^K I_{k,1}^{II}(\underline{b}_k^I, \tau_k, \phi_k)$$

where $\underline{b}^I = (b_{2,-1}^I, b_{2,0}^I, \dots, b_{K,-1}^I, b_{K,0}^I)$. Similarly, the component of the I-channel correlator output due to a Q-channel interferer is

$$\begin{aligned} D_k &= \int_0^T \sqrt{2P} \sin \beta \cdot a_k^Q(t-\tau_k)b_k^Q(t-\tau_k) \sin(2\pi f_c t + \phi_k) a_1^I(t) \cos(2\pi f_c t) dt \\ &= \sqrt{2P} \sin \beta \int_0^T b_k^Q(t-\tau_k) a_k^Q(t-\tau_k) a_1^I(t) \sin(2\pi f_c t + \phi_k) \cos(2\pi f_c t) dt \\ &= \sqrt{2P} \sin \beta \int_0^T b_k^Q(t-\tau_k) a_k^Q(t-\tau_k) a_1^I(t) \frac{1}{2} \left[\sin(\phi_k) + \sin(4\pi f_c t + \phi_k) \right] dt \\ &= \sqrt{P/2} \sin \beta \cdot \sin(\phi_k) \int_0^T b_k^Q(t-\tau_k) a_k^Q(t-\tau_k) a_1^I(t) dt \\ &= \sqrt{P/2} \sin \beta \cdot \sin(\phi_k) \left[b_{k,-1}^Q R_{k,1}^{QI}(\tau_k) + b_{k,0}^Q \widehat{R}_{k,1}^{QI}(\tau_k) \right] \end{aligned} \quad (5)$$

where, analogously to Eqs. (2) through (4), we define

$$R_{k,i}^{QI}(\tau) = \int_0^\tau a_k^Q(t-\tau)a_i^I(t)dt$$

$$\widehat{R}_{k,i}^{QI}(\tau) = \int_\tau^T a_k^Q(t-\tau)a_i^I(t)dt$$

and

$$I_{k,i}^{QI}(\underline{b}_k^Q, \tau, \phi) = T^{-1} \left[b_{k,-1}^Q R_{k,1}^{QI}(\tau_k) + b_{k,0}^Q \widehat{R}_{k,1}^{QI}(\tau_k) \right] \sin \phi$$

Then Eq. (5) can be written as

$$D_k = T\sqrt{P/2} \sin \beta \cdot I_{k,1}^{QI}(\underline{b}_k^Q, \tau_k, \phi_k)$$

and hence the total Q-channel interference is

$$\sum_{k=2}^K D_k = T\sqrt{P/2} \sin \beta \sum_{k=2}^K I_{k,1}^{QI}(\underline{b}_k^Q, \tau_k, \phi_k)$$

where $\underline{b}^Q = (b_{2,-1}^Q, b_{2,0}^Q, \dots, b_{K,-1}^Q, b_{K,0}^Q)$. The noise component of the I-channel correlator output is

$$n_1^I = \int_0^T n(t) a_1^I(t) \cos(2\pi f_c t) dt$$

Note that n_1^I is Gaussian with zero mean and variance $N_0 T/4$. In summary, we have

$$\begin{aligned} Z_1^I &= T\sqrt{\frac{P}{2}} \cos \beta \cdot b_{1,0}^I + \sum_{k=2}^K T\sqrt{\frac{P}{2}} \cos \beta \cdot I_{k,1}^{II}(\underline{b}_k^I, \tau_k, \phi_k) + \sum_{k=2}^K T\sqrt{\frac{P}{2}} \sin \beta \cdot I_{k,1}^{QI}(\underline{b}_k^Q, \tau_k, \phi_k) + n_1^I \\ &= T\sqrt{\frac{P}{2}} \left\{ b_{1,0}^I \cos \beta + \cos \beta \sum_{k=2}^K I_{k,1}^{II}(\underline{b}_k^I, \tau_k, \phi_k) + \sin \beta \sum_{k=2}^K I_{k,1}^{QI}(\underline{b}_k^Q, \tau_k, \phi_k) \right\} + n_1^I \\ &= T\sqrt{\frac{P}{2}} [\cos \beta (b_{1,0}^I + I_I)] \end{aligned}$$

where

$$I_I = \sum_{k=2}^K I_{k,1}^{II}(\underline{b}_k^I, \tau_k, \phi_k) + \tan \beta \cdot I_{k,1}^{QI}(\underline{b}_k^Q, \tau_k, \phi_k)$$

Similarly, for the Q-channel correlator output we have

$$\begin{aligned} Z_1^Q &= T\sqrt{P/2} \left\{ b_{1,0}^Q \sin \beta + \cos \beta \sum_{k=2}^K I_{k,1}^{IQ}(\underline{b}_k^I, \tau_k, \phi_k) + \sin \beta \sum_{k=2}^K I_{k,1}^{QQ}(\underline{b}_k^Q, \tau_k, \phi_k) \right\} + n_1^Q \\ &= T\sqrt{P/2} [\sin \beta (b_{1,0}^Q + I_Q)] \end{aligned}$$

where

$$I_Q = \sum_{k=2}^K I_{k,1}^{QQ} \left(\underline{b}_k^I, \tau_k, \phi_k \right) + \cot \beta I_{k,1}^{IQ} \left(\underline{b}_k^Q, \tau_k, \phi_k \right)$$

$$I_{k,i}^{IQ} \left(\underline{b}_k^I, \tau, \phi \right) = T^{-1} \left[b_{k,-1}^I R_{k,1}^{IQ}(\tau_k) + b_{k,0}^I \widehat{R}_{k,1}^{IQ}(\tau_k) \right] \sin(-\phi)$$

$$I_{k,i}^{QQ} \left(\underline{b}_k^Q, \tau, \phi \right) = T^{-1} \left[b_{k,-1}^Q R_{k,1}^{QQ}(\tau_k) + b_{k,0}^Q \widehat{R}_{k,1}^{QQ}(\tau_k) \right] \cos \phi$$

and

$$R_{k,i}^{IQ}(\tau) = \int_0^\tau a_k^I(t-\tau) a_i^Q(t) dt$$

$$\widehat{R}_{k,i}^{IQ}(\tau) = \int_\tau^T a_k^I(t-\tau) a_i^Q(t) dt$$

$$R_{k,i}^{QQ}(\tau) = \int_0^\tau a_k^Q(t-\tau) a_i^Q(t) dt$$

$$\widehat{R}_{k,i}^{QQ}(\tau) = \int_\tau^T a_k^Q(t-\tau) a_i^Q(t) dt$$

Also, n_1^Q is Gaussian with zero mean and variance $N_0 T/4$.

B. Synchronous System

For the synchronous case wherein $\tau_k = 0$ for all $k = 1, 2, \dots, K$, the received signal is given by

$$r(t) = \sum_{k=1}^K s_k(t) + n(t)$$

With arguments similar to those in the previous section, we have the correlation receiver outputs

$$Z_1^I = n_1^I + T\sqrt{P/2} \cos \beta \left[b_{1,0}^I + \sum_{k=2}^K I_{k,1}^I(\mathbf{b}_k, \theta_k) \right]$$

$$Z_1^Q = n_1^Q + T\sqrt{P/2} \sin \beta \left[b_{1,0}^Q + \sum_{k=2}^K I_{k,1}^Q(\mathbf{b}_k, \theta_k) \right]$$

where n_1^I and n_1^Q are Gaussian with zero mean and variance $N_0 T/4$, $\mathbf{b}_k = (b_{k,0}^I, b_{k,0}^Q)$, and

$$I_{k,1}^I(\mathbf{b}_k, \theta_k) = I_{k,1}^{II}(b_{k,0}^I, \theta_k) + \tan \beta \cdot I_{k,1}^{QI}(b_{k,0}^Q, \theta_k)$$

$$I_{k,1}^Q(\mathbf{b}_k, \theta_k) = I_{k,1}^{IQ}(b_{k,0}^I, \theta_k) + \cot \beta \cdot I_{k,1}^{QQ}(b_{k,0}^Q, \theta_k)$$

with

$$I_{k,1}^{II}(b_{k,0}^I, \theta_k) = T^{-1} \cdot b_{k,0}^I \cdot R_{k,1}^{II}(0) \cdot \cos(\theta_k)$$

$$I_{k,1}^{QI}(b_{k,0}^Q, \theta_k) = T^{-1} \cdot b_{k,0}^Q \cdot R_{k,1}^{QI}(0) \cdot \sin(\theta_k)$$

$$I_{k,1}^{IQ}(b_{k,0}^I, \theta_k) = T^{-1} \cdot b_{k,0}^I \cdot R_{k,1}^{IQ}(0) \cdot \sin(-\theta_k)$$

$$I_{k,1}^{QQ}(b_{k,0}^Q, \theta_k) = T^{-1} \cdot b_{k,0}^Q \cdot R_{k,1}^{QQ}(0) \cdot \cos(\theta_k)$$

Since there is no delay between users, we have

$$R_{k,1}^{II}(0) = \int_0^T a_k^I(t) a_1^I(t) dt = \sum_{j=0}^{N-1} a_{k,j}^I a_{1,j}^I \int_0^{T_c} \psi^2(t) dt$$

$$R_{k,1}^{QI}(0) = \int_0^T a_k^Q(t) a_1^I(t) dt = \sum_{j=0}^{N-1} a_{k,j}^Q a_{1,j}^I \int_0^{T_c} \psi^2(t) dt$$

$$R_{k,1}^{IQ}(0) = \int_0^T a_k^I(t) a_1^Q(t) dt = \sum_{j=0}^{N-1} a_{k,j}^I a_{1,j}^Q \int_0^{T_c} \psi^2(t) dt$$

$$R_{k,1}^{QQ}(0) = \int_0^T a_k^Q(t) a_1^Q(t) dt = \sum_{j=0}^{N-1} a_{k,j}^Q a_{1,j}^Q \int_0^{T_c} \psi^2(t) dt$$

Furthermore, since we use a rectangular chip waveform, that is, $\psi(t) = p_{T_c}(t)$, then $\int_0^{T_c} \psi^2(t) dt = T_c$, and we can further simplify the above expressions as

$$R_{k,1}^{II}(0) = T_c \sum_{j=0}^{N-1} a_{k,j}^I a_{1,j}^I$$

$$R_{k,1}^{QI}(0) = T_c \sum_{j=0}^{N-1} a_{k,j}^Q a_{1,j}^I$$

$$R_{k,1}^{IQ}(0) = T_c \sum_{j=0}^{N-1} a_{k,j}^I a_{1,j}^Q$$

$$R_{k,1}^{QQ}(0) = T_c \sum_{j=0}^{N-1} a_{k,j}^Q a_{1,j}^Q$$

III. Exact Performance Analysis

Our goal is to analyze the bit-error rate (BER) of such a system. In order to find the exact BER, we need to find the probability distribution of the interference. In this section, we derive the pdf of the interference for both synchronous and asynchronous cases.

A. Average Probability of Error

The average probability of bit error is given by

$$P_e = \frac{1}{2} (P_e^I + P_e^Q)$$

where P_e^I and P_e^Q are the average probabilities of bit error of the I and Q channels, respectively, and are evaluated as follows:

$$\begin{aligned} P_e^I &= \frac{1}{2} \left\{ \Pr(Z_1^I \leq 0 | b_{1,0}^I = +1) + \Pr(Z_1^I > 0 | b_{1,0}^I = -1) \right\} \\ &= \frac{1}{2} \left\{ \Pr\left(T\sqrt{P/2} \cos\beta(1 + I_I) + n_1^I \leq 0\right) + \Pr\left(T\sqrt{P/2} \cos\beta(-1 + I_I) + n_1^I > 0\right) \right\} \\ &= \frac{1}{2} \left\{ \Pr\left(\frac{n_1^I}{T\sqrt{P/2} \cos\beta} \leq -1 - I_I\right) + \Pr\left(\frac{n_1^I}{T\sqrt{P/2} \cos\beta} > 1 - I_I\right) \right\} \\ &= \frac{1}{2} \left\{ \Pr(n_I + I_I \leq -1) + \Pr(n_I + I_I > 1) \right\} \\ &= \frac{1}{2} \left\{ 1 - \Pr(-1 < n_I + I_I \leq 1) \right\} \end{aligned}$$

where $n_I = n_1^I / (T\sqrt{P/2} \cos\beta)$ is Gaussian with zero mean and variance $(2E_b^I/N_0)^{-1}$, $E_b^I = PT \cos^2\beta = E_s \cos^2\beta$, and $E_s = PT$. Similarly, we have

$$P_e^Q = \frac{1}{2} \left\{ 1 - \Pr(-1 < n_Q + I_Q \leq 1) \right\}$$

where $n_Q = n_1^Q / (T\sqrt{P/2} \sin\beta)$ is Gaussian with zero mean and variance $(2E_b^Q/N_0)^{-1}$, and $E_b^Q = PT \sin^2\beta = E_s \sin^2\beta$.

In order to evaluate P_e^I and P_e^Q , we use the characteristic function method in [2] to compute these probabilities. In order to compute P_e , we need to know the probability distribution of the sum of the noise and interference. We first obtain the characteristic functions of the random variables, and then derive P_e^I and P_e^Q from the characteristic functions.

Let $\Phi_{n_I}(v)$, $\Phi_{I_I}(v)$, and $\Phi_I(v)$ be the characteristic functions of n_I , I_I , and $I = n_I + I_I$. Note that they are even functions ($\Phi(v) = \Phi(-v)$), and $\Phi_I(v) = \Phi_{n_I}(v)\Phi_{I_I}(v)$ by the independence of n_I and I_I . The probability needed to compute P_e^I is obtained as

$$\begin{aligned}
\Pr(-1 < n_I + I_I \leq 1) &= \int_{-1}^1 f_I(x) dx \\
&= 2 \int_0^1 f_I(x) dx \\
&= 2 \int_0^1 \left(\frac{1}{2\pi} \int_{-\infty}^{\infty} \Phi_I(v) e^{-jvx} dv \right) dx \\
&= \frac{2}{\pi} \int_0^1 \left(\int_0^{\infty} \Phi_I(v) \cos(vx) dv \right) dx \\
&= \frac{2}{\pi} \int_0^{\infty} \Phi_I(v) \left(\int_0^1 \cos(vx) dx \right) dv \\
&= \frac{2}{\pi} \int_0^{\infty} \Phi_I(v) v^{-1} \sin(v) dv
\end{aligned}$$

The characteristic function of the interference in the I-channel, $\Phi_I(v)$, can be written as

$$\Phi_I(v) = \Phi_{n_I}(v)\Phi_{I_I}(v) = \Phi_{n_I}(v) - \Phi_{n_I}(v) + \Phi_{n_I}(v)\Phi_{I_I}(v) = \Phi_{n_I}(v) - \Phi_{n_I}(v)[1 - \Phi_{I_I}(v)]$$

thus,

$$\Pr(-1 < n_I + I_I \leq 1) = \frac{2}{\pi} \int_0^{\infty} \Phi_{n_I}(v) v^{-1} \sin(v) dv - \frac{2}{\pi} \int_0^{\infty} v^{-1} \sin(v) \Phi_{n_I}(v) [1 - \Phi_{I_I}(v)] dv$$

where

$$\Phi_{n_I}(v) = \exp\left(-\frac{N_0}{4E_b^I} v^2\right)$$

The average probability of error of the I-channel is then given by

$$\begin{aligned}
P_e^I &= \frac{1}{2} - \frac{1}{2} \Pr(-1 < n_I + I_I \leq 1) \\
&= \frac{1}{2} - \frac{1}{\pi} \int_0^{\infty} v^{-1} \sin(v) \Phi_{n_I}(v) dv + \frac{1}{\pi} \int_0^{\infty} v^{-1} \sin(v) \Phi_{n_I}(v) [1 - \Phi_{I_I}(v)] dv \\
&= Q\left(\sqrt{\frac{2E_b^I}{N_0}}\right) + \frac{1}{\pi} \int_0^{\infty} v^{-1} \sin(v) \Phi_{n_I}(v) [1 - \Phi_{I_I}(v)] dv
\end{aligned}$$

where

$$Q(x) = \frac{1}{\sqrt{2\pi}} \int_x^\infty e^{-t^2/2} dt, \quad x \geq 0$$

Similarly, let $\Phi_{n_Q}(v)$, $\Phi_{I_Q}(v)$, and $\Phi_Q(v)$ be the characteristic functions of n_Q and I_Q . Then we have

$$\Pr(-1 < n_Q + I_Q \leq 1) = \frac{2}{\pi} \int_0^\infty v^{-1} \sin(v) \Phi_{n_Q}(v) dv - \frac{2}{\pi} \int_0^\infty v^{-1} \sin(v) \Phi_{n_Q}(v) [1 - \Phi_{I_Q}(v)] dv$$

and

$$\begin{aligned} P_e^Q &= \frac{1}{2} - \frac{1}{\pi} \int_0^\infty v^{-1} \sin(v) \Phi_{n_Q}(v) dv + \frac{1}{\pi} \int_0^\infty v^{-1} \sin(v) \Phi_{n_Q}(v) [1 - \Phi_{I_Q}(v)] dv \\ &= Q\left(\sqrt{\frac{2E_b^Q}{N_0}}\right) + \frac{1}{\pi} \int_0^\infty v^{-1} \sin(v) \Phi_{n_Q}(v) [1 - \Phi_{I_Q}(v)] dv \end{aligned}$$

Therefore, the average probability of error is given by

$$\begin{aligned} P_e &= \frac{1}{2} \left\{ Q\left(\sqrt{\frac{2E_b^I}{N_0}}\right) + Q\left(\sqrt{\frac{2E_b^Q}{N_0}}\right) \right\} \\ &\quad + \frac{1}{2\pi} \int_0^\infty v^{-1} \sin(v) \{ \Phi_{n_I}(v) [1 - \Phi_{I_I}(v)] + \Phi_{n_Q}(v) [1 - \Phi_{I_Q}(v)] \} dv \end{aligned}$$

Note that by representing the error probability in this way it is clear what the contribution to error probability is from noise and interference. When there is no MAI, i.e., the single user case, the MAI term in the above expression is zero, and the probability of error is the same as in the case of an AWGN channel. In general, the MAI term in the above expression does not have a closed-form solution and needs to be evaluated numerically. However, in order to evaluate it numerically, we need to find expressions for $\Phi_{I_I}(v)$ and $\Phi_{I_Q}(v)$.

B. Asynchronous Case

Here we begin to derive the characteristic function of the interference in the asynchronous case. The I-channel interference is given by

$$I_I = \sum_{k=2}^K I_{k,1}^I(\underline{b}_k^I, \tau_k, \phi_k) + \tan \beta \cdot I_{k,1}^Q(\underline{b}_k^Q, \tau_k, \phi_k)$$

where

$$I_{k,1}^{II}(\underline{b}_k^I, \tau_k, \phi_k) = \frac{\cos(\phi_k)}{T} \left[b_{k,-1}^I R_{k,1}^{II}(\tau_k) + b_{k,0}^I \widehat{R}_{k,1}^{II}(\tau_k) \right]$$

$$I_{k,1}^{QI}(\underline{b}_k^Q, \tau_k, \phi_k) = \frac{\sin(\phi_k)}{T} \left[b_{k,-1}^Q R_{k,1}^{QI}(\tau_k) + b_{k,0}^Q \widehat{R}_{k,1}^{QI}(\tau_k) \right]$$

Now consider $lT_c \leq \tau_k \leq (l+1)T_c$. In this case, we have

$$R_{k,1}^{II}(\tau_k) = C_{k,1}^{II}(l-N) \widehat{R}_\psi(\tau_k - lT_c) + C_{k,1}^{II}(l+1-N) R_\psi(\tau_k - lT_c) \quad (6)$$

$$\widehat{R}_{k,1}^{II}(\tau_k) = C_{k,1}^{II}(l) \widehat{R}_\psi(\tau_k - lT_c) + C_{k,1}^{II}(l+1) R_\psi(\tau_k - lT_c) \quad (7)$$

where $\widehat{R}_\psi(\tau)$ and $R_\psi(\tau)$ are the autocorrelation functions of the chip waveform defined as

$$\widehat{R}_\psi(\tau) = \int_\tau^{T_c} \psi(t) \psi(t - \tau) dt$$

$$R_\psi(\tau) = \int_0^\tau \psi(t) \psi(t + T_c - \tau) dt$$

Similarly,

$$R_{k,1}^{QI}(\tau_k) = C_{k,1}^{QI}(l-N) \widehat{R}_\psi(\tau_k - lT_c) + C_{k,1}^{QI}(l+1-N) R_\psi(\tau_k - lT_c)$$

$$\widehat{R}_{k,1}^{QI}(\tau_k) = C_{k,1}^{QI}(l) \widehat{R}_\psi(\tau_k - lT_c) + C_{k,1}^{QI}(l+1) R_\psi(\tau_k - lT_c)$$

In the above expressions, $C_{k,i}^{II}(l)$ and $C_{k,i}^{QI}(l)$ are the aperiodic cross-correlation functions defined as

$$C_{k,i}^{II}(l) = \begin{cases} \sum_{j=0}^{N-1-l} a_{k,j}^I a_{i,j+l}^I, & 0 \leq l \leq N-1 \\ \sum_{j=0}^{N-1+l} a_{k,j-l}^I a_{i,j}^I, & 1-N \leq l < 0 \\ 0, & |l| \geq N \end{cases} \quad (8)$$

$$C_{k,i}^{IQ}(l) = \begin{cases} \sum_{j=0}^{N-1-l} a_{k,j}^I a_{i,j+l}^Q, & 0 \leq l \leq N-1 \\ \sum_{j=0}^{N-1+l} a_{k,j-l}^I a_{i,j}^Q, & 1-N \leq l < 0 \\ 0, & |l| \geq N \end{cases} \quad (9)$$

Here $\{a_{k,j}^I\}$ and $\{a_{k,j}^Q\}$ are the spreading sequences of the I and Q channels of the k th user. The characteristic function of I_I is given by

$$\begin{aligned}
\Phi_{I_I}(v) &= E\{\exp(jvI_I)\} \\
&= E\left\{\exp\left[jv\left(\sum_{k=2}^K I_{k,1}^{II}(\underline{b}_k^I, \tau_k, \phi_k) + \tan\beta \cdot I_{k,1}^{QI}(\underline{b}_k^Q, \tau_k, \phi_k)\right)\right]\right\} \\
&= \prod_{k=2}^K E\left\{\exp\left[jv\left(I_{k,1}^{II}(\underline{b}_k^I, \tau_k, \phi_k) + \tan\beta \cdot I_{k,1}^{QI}(\underline{b}_k^Q, \tau_k, \phi_k)\right)\right]\right\} \\
&= \prod_{k=2}^K \left\{ \frac{1}{2\pi} \frac{1}{T} \left(\frac{1}{4}\right) \left(\frac{1}{4}\right) \sum_{\underline{b}_k^I} \sum_{\underline{b}_k^Q} \int_0^{2\pi} \int_0^T \exp\left[jv\left(I_{k,1}^{II}(\underline{b}_k^I, \tau, \phi) + \tan\beta \cdot I_{k,1}^{QI}(\underline{b}_k^Q, \tau, \phi)\right)\right] d\tau d\phi \right\} \\
&= \prod_{k=2}^K \left\{ \frac{1}{32\pi T} \sum_{\underline{b}_k^I} \sum_{\underline{b}_k^Q} \int_0^{2\pi} \sum_{l=0}^{N-1} \int_{lT_c}^{(l+1)T_c} \exp\left[jv \frac{\cos\phi}{T} \left[b_{k,-1}^I(C_{k,1}^{II}(l-N)\widehat{R}_\psi(\tau-lT_c) \right. \right. \right. \\
&\quad \left. \left. \left. + C_{k,-1}^{II}(l+1-N)R_\psi(\tau-lT_c)\right) \right. \right. \\
&\quad \left. \left. \left. + b_{k,0}^I \left(C_{k,1}^{II}(l)\widehat{R}_\psi(\tau-lT_c) + C_{k,1}^{II}(l+1)R_\psi(\tau-lT_c)\right)\right] \right. \right. \\
&\quad \left. \left. \left. + jv \tan\beta \frac{\sin\phi}{T} \left[b_{k,-1}^Q \left(C_{k,1}^{QI}(l-N)\widehat{R}_\psi(\tau-lT_c) + C_{k,-1}^{QI}(l+1-N)R_\psi(\tau-lT_c)\right) \right. \right. \right. \\
&\quad \left. \left. \left. + b_{k,0}^Q \left(C_{k,1}^{QI}(l)\widehat{R}_\psi(\tau-lT_c) + C_{k,1}^{QI}(l+1)R_\psi(\tau-lT_c)\right)\right] \right] d\tau d\phi \right\} \tag{10}
\end{aligned}$$

With further simplification (see Appendix A), we obtain

$$\Phi_{I_I}(v) = \prod_{k=2}^K \left\{ \frac{1}{8N} \sum_{l=0}^{N-1} \left(\sum_{i=1}^8 f(v; l, g_i(l), h_i(l), \alpha_i) \right) \right\}$$

where

$$\begin{aligned}
f(v; l, g(l), h(l), \alpha) &\triangleq \frac{1}{2\pi T_c} \int_0^{2\pi} \int_0^{T_c} \cos\left\{\frac{v}{T} \left[(\cos\phi \cdot g(l) + \alpha \sin\phi \cdot h(l))\widehat{R}_\psi(\tau) \right. \right. \\
&\quad \left. \left. + (\cos\phi \cdot g(l+1) + \alpha \sin\phi \cdot h(l+1))R_\psi(\tau)\right]\right\} d\tau d\phi
\end{aligned}$$

and

$$\begin{aligned}
g_1(l) &= \theta_{k,1}^{II}, & h_1(l) &= \theta_{k,1}^{QI}, & \alpha_1 &= \tan \beta \\
g_2(l) &= \theta_{k,1}^{II}, & h_2(l) &= \widehat{\theta}_{k,1}^{QI}, & \alpha_2 &= -\tan \beta \\
g_3(l) &= \theta_{k,1}^{II}, & h_3(l) &= \widehat{\theta}_{k,1}^{QI}, & \alpha_3 &= \tan \beta \\
g_4(l) &= \theta_{k,1}^{II}, & h_4(l) &= \theta_{k,1}^{QI}, & \alpha_4 &= -\tan \beta \\
g_5(l) &= \widehat{\theta}_{k,1}^{II}, & h_5(l) &= \theta_{k,1}^{QI}, & \alpha_5 &= -\tan \beta \\
g_6(l) &= \widehat{\theta}_{k,1}^{II}, & h_6(l) &= \widehat{\theta}_{k,1}^{QI}, & \alpha_6 &= \tan \beta \\
g_7(l) &= \widehat{\theta}_{k,1}^{II}, & h_7(l) &= \widehat{\theta}_{k,1}^{QI}, & \alpha_7 &= -\tan \beta \\
g_8(l) &= \widehat{\theta}_{k,1}^{II}, & h_8(l) &= \theta_{k,1}^{QI}, & \alpha_8 &= \tan \beta
\end{aligned}$$

If we consider a rectangular chip waveform, we can further simplify the function $f(v; l, g(l), h(l), \alpha)$ as (see Appendix A)

$$\begin{aligned}
f(v; l, g(l), h(l), \alpha) &= \frac{1}{2\pi} \int_0^{2\pi} \text{sinc} \left\{ \frac{v}{2\pi N} \left(\cos \phi (g(l+1) - g(l)) + \alpha \sin \phi (h(l+1) - h(l)) \right) \right\} \\
&\quad \cdot \cos \left\{ \frac{v}{2N} \left(\cos \phi (g(l+1) + g(l)) + \alpha \sin \phi (h(l+1) + h(l)) \right) \right\} d\phi
\end{aligned}$$

This expression is simple to evaluate numerically, which allows us to compute the characteristic function and the average error probability. From the above expression, we see that the characteristic function of the interference does not depend on the signal energy or SNR. The advantage is that we need to compute the characteristic function of the interference only once, and it can be applied to different SNR values to compute the probability of error.

C. Synchronous Case

For the synchronous case, the derivation is similar to the asynchronous case. The expressions for the bit-error probability for the I and Q channels are the same as for the asynchronous case. The only difference is in the expressions for the characteristic functions of the interference. These are given by

$$\begin{aligned}
\Phi_{I_I}(v) &= \prod_{k=2}^K \left\{ \frac{1}{4\pi} \int_0^{2\pi} \cos \left(\frac{v}{T} [\cos \phi \cdot R_{k,1}^{II}(0) + \tan \beta \cdot \sin \phi \cdot R_{k,1}^{QI}(0)] \right) \right. \\
&\quad \left. + \cos \left(\frac{v}{T} [\cos \phi \cdot R_{k,1}^{II}(0) - \tan \beta \cdot \sin \phi \cdot R_{k,1}^{QI}(0)] \right) d\phi \right\} \\
\Phi_{I_Q}(v) &= \prod_{k=2}^K \left\{ \frac{1}{4\pi} \int_0^{2\pi} \cos \left(\frac{v}{T} [\cos \phi \cdot R_{k,1}^{QQ}(0) + \cot \beta \cdot \sin \phi \cdot R_{k,1}^{IQ}(0)] \right) \right. \\
&\quad \left. + \cos \left(\frac{v}{T} [\cos \phi \cdot R_{k,1}^{QQ}(0) - \cot \beta \cdot \sin \phi \cdot R_{k,1}^{IQ}(0)] \right) d\phi \right\}
\end{aligned}$$

D. Numerical Examples

Here we present a numerical example for the asynchronous case. In [2], the average error probability for a direct-sequence spread-spectrum multiple-access (DS-SSMA) system with symmetric QPSK modulation is investigated. The performance is evaluated using auto-optimal, least side-lobe energy (AO/LSE) sequences [10] as the spreading codes for the users in the system. For the quaternary system, the spreading factor is chosen to be $N = 127$, and there are 9 pairs of codes listed. In each pair of codes, the I- and Q-channel sequences are the reverse of each other. The AO/LSE codes for $N = 127$ are listed in Table 1.

Each row represents a pair of codes. The generator polynomial coefficients are denoted by H and H^{-1} in octal. The initial values in the shift registers are denoted by $\underline{\alpha}_0$ and $\underline{\alpha}_0^{-1}$. The in-phase interference characteristic function from the second user to the first user using the above spreading codes with $\beta = \pi/4$ is shown in Fig. 3. Since in the symmetric constellation the I- and Q-channel signals have the same power, the resulting characteristic functions of the I- and Q-channel interference are the same. Therefore, we show only the characteristic function of the I channel. For $\beta = \pi/8$, even though we use mutually reversed spreading codes for in-phase and quadrature-phase components, the characteristic functions are different. This is due to the unequal power of the I- and Q-channel signals in the asymmetric constellation and the cross-correlation nature of the spreading codes. The characteristic functions of the interference from the second user to the first user when $\beta = \pi/8$ are shown in Fig. 4. The average probability of error when the number of users varies from 1 to 9 is shown in Fig. 5. The performance is worse than the symmetric case as shown in [2]. This is because the performance is dominated by the Q-channel performance, which is bad due to the low transmitted power.

IV. Approximate Performance Analysis

As seen in the previous section, the expressions for the interference are very complicated, and the evaluation for the exact performance is computationally tedious. Also, as in the numerical example, the results are for a specific set of signature sequences. One way to solve this problem is to use a Gaussian approximation to model the interference and to use random signature sequences in the analysis. Then a simple approximate expression for the BER can be obtained involving only the signal-to-interference-plus-noise ratio (SINR) and the Q function. In this section, we approximate the interference as a Gaussian random variable and assume random signature sequences. We find the variance of the interference and examine the approximate system performance.

Table 1. AO/LSE codes ($N = 127$).

H	$\underline{\alpha}_0$	H^{-1}	$\underline{\alpha}_0^{-1}$	\hat{M}	\hat{L}	S
211	0010000	221	1001101	17	6	2183
217	0000101	361	1111111	15	12	2015
235	0001100	271	1000101	17	10	2283
247	0010111	345	0110001	17	8	2255
277	1110001	375	0101010	19	4	2295
357	1110010	367	0110101	17	4	2563
323	1110111	313	1000111	17	4	2203
203	1101101	301	0010010	17	4	2087
325	0000101	253	1101100	19	6	2483

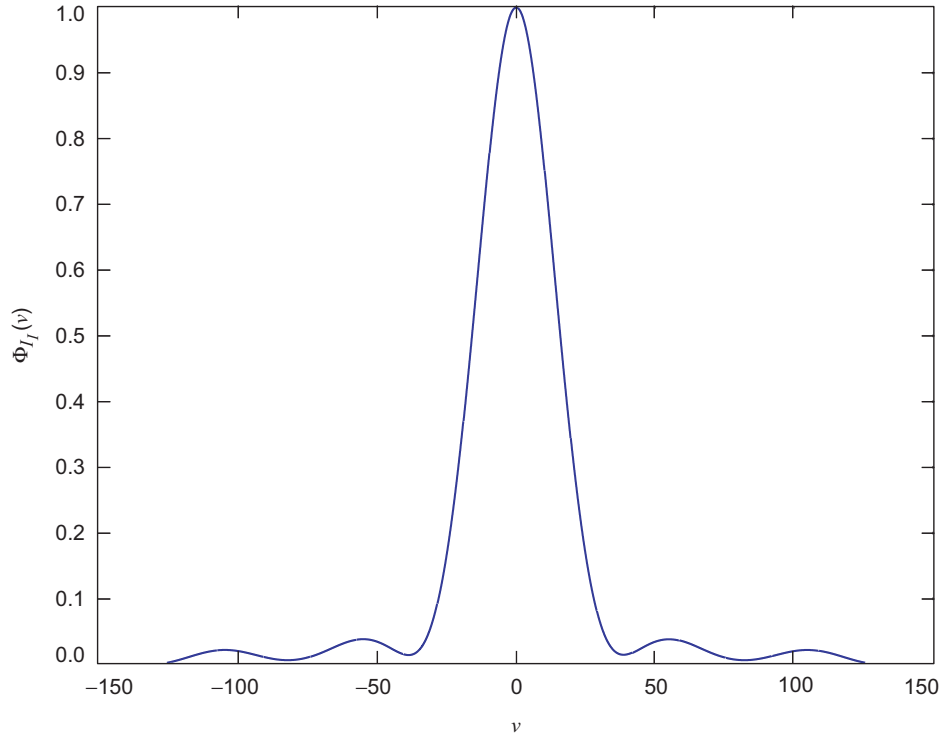

Fig. 3. In-phase interference characteristic function ($N = 127, \beta = \pi/4$).

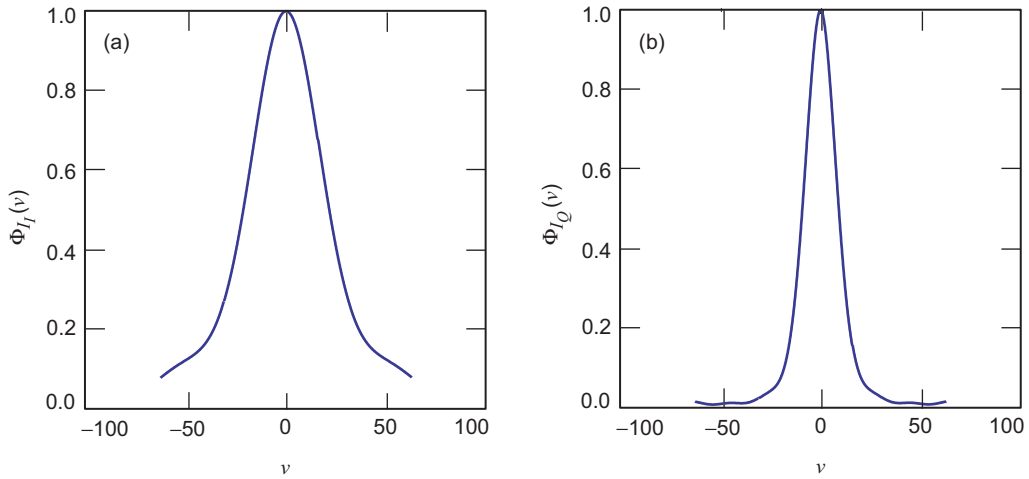

Fig. 4. Interference characteristic functions ($N = 127, \beta = \pi/8$): (a) in-phase and (b) quadrature.

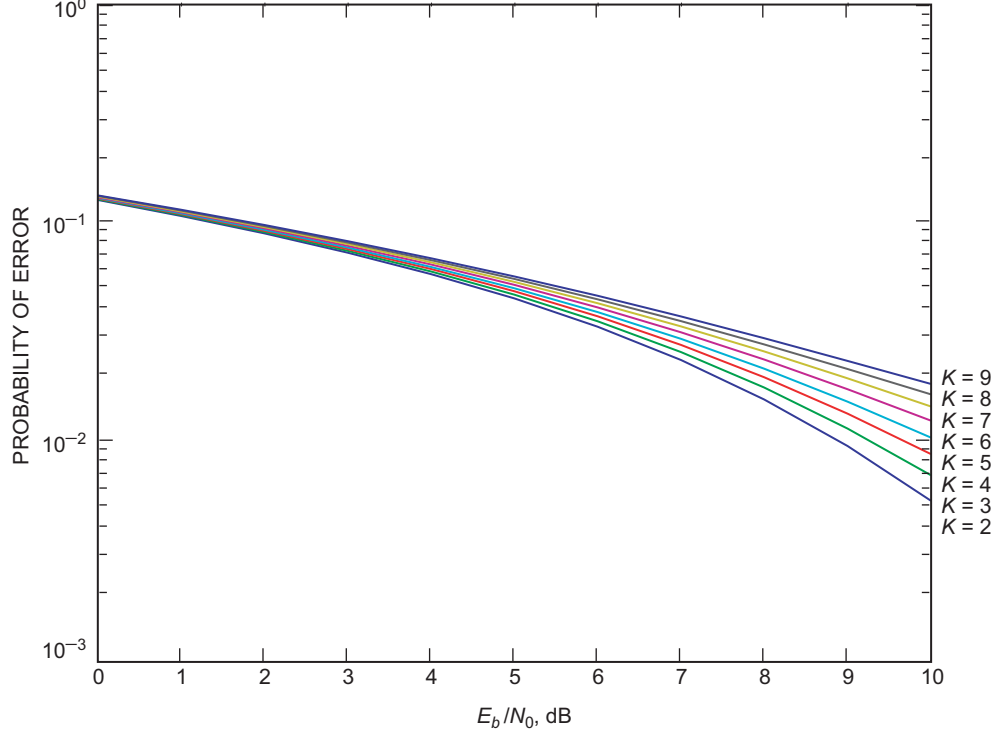

Fig. 5. Probability of error for asymmetric QPSK DS-SSMA ($N = 127$, $\beta = \pi/8$).

A. Asynchronous Case

In order to find the approximate BER performance, we approximate the interference as a Gaussian random variable and find its variance. We first find the conditional variance of the interference, and then average over the random variables to find the variance. Therefore, we can obtain an expression for the SINR, and thus the approximate BER.

The decision statistics at the output of the correlation receiver for user 1 are

$$Z_1^I = n_1^I + T\sqrt{P/2} \cdot \cos \beta \cdot b_{1,0}^I + \sqrt{P/2} \sum_{k=2}^K \cos \beta \cdot W_k^{II} \cdot \cos(\phi_k) + \sin \beta \cdot W_k^{QI} \cdot \sin(\phi_k)$$

$$Z_1^Q = n_1^Q + T\sqrt{P/2} \cdot \cos \beta \cdot b_{1,0}^Q + \sqrt{P/2} \sum_{k=2}^K \sin \beta \cdot W_k^{QQ} \cdot \cos(\phi_k) - \cos \beta \cdot W_k^{IQ} \cdot \sin(\phi_k)$$

where

$$W_k^{II} = b_{k,-1}^I \cdot R_{k,1}^{II}(\tau_k) + b_{k,0}^I \cdot \widehat{R}_{k,1}^{II}(\tau_k)$$

$$W_k^{QI} = b_{k,-1}^Q \cdot R_{k,1}^{QI}(\tau_k) + b_{k,0}^Q \cdot \widehat{R}_{k,1}^{QI}(\tau_k)$$

$$W_k^{QQ} = b_{k,-1}^Q \cdot R_{k,1}^{QQ}(\tau_k) + b_{k,0}^Q \cdot \widehat{R}_{k,1}^{QQ}(\tau_k)$$

$$W_k^{IQ} = b_{k,-1}^I \cdot R_{k,1}^{IQ}(\tau_k) + b_{k,0}^I \cdot \widehat{R}_{k,1}^{IQ}(\tau_k)$$

To find the variance of the multiple access interference (MAI) of Z_1^I and Z_1^Q , we start by writing Z_1^I in the form

$$Z_1^I = n_1^I + T\sqrt{P/2} \cdot b_{1,0}^I \cdot \cos \beta + W$$

where

$$W = \sqrt{P/2} \cdot \cos \beta \sum_{k=2}^K W_k^{II} \cdot \cos(\phi_k) + \sqrt{P/2} \cdot \sin \beta \sum_{k=2}^K W_k^{QI} \cdot \sin(\phi_k) = W^I + W^Q$$

with

$$W^I = \sqrt{P/2} \cdot \cos \beta \sum_{k=2}^K W_k^{II} \cdot \cos(\phi_k)$$

$$W^Q = \sqrt{P/2} \cdot \sin \beta \sum_{k=2}^K W_k^{QI} \cdot \sin(\phi_k)$$

The variances of W^I and W^Q are given by (see Appendix B)

$$\text{Var}[W^I] = \frac{(K-1)NPT_c^2 \cos^2 \beta}{6}$$

$$\text{Var}[W^Q] = \frac{(K-1)NPT_c^2 \sin^2 \beta}{6}$$

Hence, the variance of the MAI in Z_1^I is given by

$$\text{Var}[W] = \text{Var}[W^I] + \text{Var}[W^Q] = \frac{(K-1)NPT_c^2}{6}$$

The SINR of Z_1^I is then

$$\begin{aligned} \text{SINR}_I &= \frac{T^2 P/2 \cdot \cos^2 \beta}{\frac{N_0 T}{4} + \frac{(K-1)NPT_c^2}{6}} \\ &= \frac{6E_s \cdot \cos^2 \beta}{3N_0 + 2E_s \frac{(K-1)}{N}} \\ &= \frac{12E_b \cdot \cos^2 \beta}{3N_0 + 4E_b \frac{(K-1)}{N}} \end{aligned}$$

where $E_s = NPT_c$ is the symbol energy, and $E_b = (1/2)E_s$ is the average bit energy. Similarly, for the Q channel, the SINR of Z_1^Q is given by

$$\text{SINR}_Q = \frac{6E_s \cdot \sin^2 \beta}{3N_0 + 2E_s \frac{(K-1)}{N}} = \frac{12E_b \cdot \sin^2 \beta}{3N_0 + 4E_b \frac{(K-1)}{N}}$$

Then, the approximate BER can be expressed as

$$P_{e,GA}^I = Q \left(\sqrt{\frac{12E_b \cdot \cos^2 \beta}{3N_0 + 4E_b \frac{(K-1)}{N}}} \right)$$

$$P_{e,GA}^Q = Q \left(\sqrt{\frac{12E_b \cdot \sin^2 \beta}{3N_0 + 4E_b \frac{(K-1)}{N}}} \right)$$

B. Synchronous Case

The analysis for the synchronous case is similar to that for the asynchronous case presented in the previous subsection. We can rewrite the decision statistic as

$$Z_1^I = n_1^I + T\sqrt{P/2} \cdot \cos \beta \cdot b_{1,0}^I + W$$

where

$$W = \sum_{k=2}^K W_k^I$$

and

$$W_k^I = \sqrt{P/2} \left(\cos \beta \cdot b_{k,0}^I \cdot R_{k,1}^{II}(0) \cdot \cos(\theta_k) + \sin \beta \cdot b_{k,0}^Q \cdot R_{k,1}^{QI}(0) \cdot \sin(\theta_k) \right)$$

We want to find the variance of the MAI W_k^I . Note that $R_{k,1}^{II}(0)$ and $R_{k,1}^{QI}(0)$ are both functions of $\{a_{1,j}^I\}$. Thus, the variance of W_k^I conditioned on $\{a_{1,j}^I\}$ and θ_k is

$$\begin{aligned}
\text{Var}[W_k^I | \{a_{1,j}^I\}, \theta_k] &= \text{Var}\left[\sqrt{P/2} \cdot \cos \beta \cdot b_{k,0}^I \cdot R_{k,1}^{II}(0) \cdot \cos \theta_k \mid \{a_{1,j}^I\}, \theta_k\right] \\
&\quad + \text{Var}\left[\sqrt{P/2} \cdot \sin \beta \cdot b_{k,0}^Q \cdot R_{k,1}^{QI}(0) \cdot \sin \theta_k \mid \{a_{1,j}^I\}, \theta_k\right] \\
&= \frac{P}{2} \left(\cos^2 \beta \cdot \cos^2 \theta_k \cdot \text{Var}\left[b_{k,0}^I \cdot R_{k,1}^{II}(0) \mid \{a_{1,j}^I\}\right] \right. \\
&\quad \left. + \sin^2 \beta \cdot \sin^2 \theta_k \cdot \text{Var}\left[b_{k,0}^Q \cdot R_{k,1}^{QI}(0) \mid \{a_{1,j}^I\}\right] \right)
\end{aligned}$$

Because we assume random signature sequences, given $\{a_{1,j}^I\}$, $R_{k,1}^{II}(0)$ and $R_{k,1}^{QI}(0)$ are independent identically distributed (i.i.d.) with pdf

$$p_R(rT_c) = \binom{N}{\frac{r+N}{2}} 2^{-N}$$

for $r = -N, -N+2, \dots, N-2, N$. Since $b_{k,0}^I$ and $R_{k,1}^{II}$ have zero mean and are independent, we have

$$\begin{aligned}
\text{Var}[b_{k,0}^I \cdot R_{k,1}^{II}(0) | \{a_{1,j}^I\}] &= E\left[(b_{k,0}^I \cdot R_{k,1}^{II}(0))^2 \mid \{a_{1,j}^I\}\right] \\
&= E\left[(b_{k,0}^I)^2\right] E\left[(R_{k,1}^{II}(0))^2 \mid \{a_{1,j}^I\}\right] \\
&= 1 \cdot NT_c^2 \\
&= NT_c^2
\end{aligned}$$

Note that even though $R_{k,1}^{II}(0)$ depends on $\{a_{1,j}^I\}$, the mean and variance do not depend on the particular realization of $\{a_{1,j}^I\}$. This is different from the asynchronous case. However, this property helps reduce the complexity of the analysis. Similarly, we have $\text{Var}[b_{k,0}^Q \cdot R_{k,1}^{QI}(0) | \{a_{1,j}^I\}] = NT_c^2$. Therefore, the conditional variance of W_k^I is

$$\text{Var}[W_k^I | \theta_k, \{a_{1,j}^I\}] = \frac{NPT_c^2}{2} (\cos^2 \beta \cdot \cos^2 \theta_k + \sin^2 \beta \cdot \sin^2 \theta_k)$$

Let $\Theta = (\theta_1, \dots, \theta_K)$. The conditional variance of W is then given by

$$\begin{aligned}
\text{Var}[W | \Theta, \{a_{1,j}^I\}] &= \sum_{k=2}^K \text{Var}[W_k^I | \theta_k, \{a_{1,j}^I\}] \\
&= (K-1) \frac{NPT_c^2}{2} (\cos^2 \beta \cdot \cos^2 \theta_k + \sin^2 \beta \cdot \sin^2 \theta_k)
\end{aligned}$$

Note that the above expression now depends only on θ_k . By averaging over θ_k , the variance of W is

$$\begin{aligned}
\text{Var}[W] &= \sum_{k=2}^K E_{\theta_k} [\text{Var}[W_k^I | \theta_k]] \\
&= (K-1)E_{\theta_k} \left[\frac{NPT_c^2}{2} (\cos^2 \beta \cdot \cos^2 \theta_k + \sin^2 \beta \cdot \sin^2 \theta_k) \right] \\
&= \frac{(K-1)NPT_c^2}{2} (\cos^2 \beta \cdot E_{\theta_k}[\cos^2 \theta_k] + \sin^2 \beta \cdot E_{\theta_k}[\sin^2 \theta_k]) \\
&= \frac{(K-1)NPT_c^2}{2} \left(\cos^2 \beta \cdot \frac{1}{2} + \sin^2 \beta \cdot \frac{1}{2} \right) \\
&= \frac{(K-1)NPT_c^2}{4}
\end{aligned}$$

Therefore, the SINR is

$$\begin{aligned}
\text{SINR}_I &= \frac{T^2 P/2 \cdot \cos^2 \beta}{N_0 T/4 + (K-1)NPT_c^2/4} \\
&= \frac{2NT_c E_s \cos^2 \beta}{N_0 NT_c + (K-1)T_c E_s} \\
&= \frac{2E_s \cos^2 \beta}{N_0 + \frac{(K-1)}{N} E_s} \\
&= \frac{4E_b \cos^2 \beta}{N_0 + \frac{2(K-1)}{N} E_b}
\end{aligned}$$

By approximating the MAI as Gaussian with variance $(K-1)NP/4$, the approximate I-channel average probability of bit error is

$$P_{e,GA}^I = Q\left(\sqrt{\text{SINR}_I}\right) = Q\left(\sqrt{\frac{4E_b \cos^2 \beta}{N_0 + \frac{2(K-1)}{N} E_b}}\right)$$

Similarly, it can be shown that, for the Q channel, the approximate average probability of bit error is

$$P_{e,GA}^Q = Q \left(\sqrt{\frac{4E_b \sin^2 \beta}{N_0 + \frac{2(K-1)}{N} E_b}} \right)$$

V. A Generalized Model and the Near-Far Problem

In this section, we consider a general model for the AQPSK DS-CDMA system. The main difference from the model in the previous sections is that the users can have different transmission power. This causes what is referred to as “the near-far problem.” We are interested in the near-far effect on system performance.

A. Analysis

In the general model, the in-phase and quadrature components are given by

$$s_k^I(t) = A_k \cos \beta \cdot a_k^I(t) b_k^I(t) \cos(2\pi f_c t + \theta_k)$$

$$s_k^Q(t) = A_k \sin \beta \cdot a_k^Q(t) b_k^Q(t) \sin(2\pi f_c t + \theta_k)$$

where A_1, A_2, \dots, A_K can be different. Without loss of generality, let user 1 be the desired user. The correlation receiver output of the in-phase and quadrature-phase channels are

$$Z_1^I = \frac{1}{2} A_1 T \left\{ b_{1,0}^I \cos \beta + \cos \beta \sum_{k=2}^K \frac{A_k}{A_1} I_{k,1}^I(\underline{b}_k^I, \tau_k, \phi_k) + \sin \beta \sum_{k=2}^K \frac{A_k}{A_1} I_{k,1}^{QI}(\underline{b}_k^Q, \tau_k, \phi_k) \right\} + n_1^I$$

$$Z_1^Q = \frac{1}{2} A_1 T \left\{ b_{1,0}^Q \sin \beta + \cos \beta \sum_{k=2}^K \frac{A_k}{A_1} I_{k,1}^{IQ}(\underline{b}_k^I, \tau_k, \phi_k) + \sin \beta \sum_{k=2}^K \frac{A_k}{A_1} I_{k,1}^Q(\underline{b}_k^Q, \tau_k, \phi_k) \right\} + n_1^Q$$

The average probability of error is given by

$$P_e = \frac{1}{2} (P_e^I + P_e^Q)$$

with

$$P_e^I = \frac{1}{2} \left\{ 1 - P \left(-1 < \frac{2n_1^I}{A_1 T \cos \beta} + I_1^I \leq 1 \right) \right\}$$

$$P_e^Q = \frac{1}{2} \left\{ 1 - P \left(-1 < \frac{2n_1^Q}{A_1 T \sin \beta} + I_1^Q \leq 1 \right) \right\}$$

where

$$I_1^I = \sum_{k=2}^K \frac{A_k}{A_1} \left[I_{k,1}^{II}(\underline{b}_k^I, \tau_k, \phi_k) + \tan \beta I_{k,1}^{QI}(\underline{b}_k^Q, \tau_k, \phi_k) \right]$$

$$I_1^Q = \sum_{k=2}^K \frac{A_k}{A_1} \left[I_{k,1}^{QQ}(\underline{b}_k^Q, \tau_k, \phi_k) + \cot \beta I_{k,1}^{IQ}(\underline{b}_k^I, \tau_k, \phi_k) \right]$$

The characteristic function of I_1^I is

$$\Phi_{I_1^I}(v) = \prod_{k=2}^K \Phi_{I_{k,1}^I}(v)$$

where

$$\Phi_{I_{k,1}^I}(v) = \frac{1}{8N} \sum_{l=0}^{N-1} \sum_{i=1}^8 f \left(v; l, g_{k,i}^I(l), h_{k,i}^I(l), \alpha_i^I, \frac{A_k}{A_1} \right)$$

and

$$f(v; l, g(l), h(l), \alpha, \gamma) = \frac{1}{2\pi} \int_0^{2\pi} \text{sinc} \left\{ \gamma \frac{v}{2\pi N} (\cos \phi (g(l+1) - g(l)) + \alpha \sin \phi (h(l+1) - h(l))) \right\} \\ \cdot \cos \left\{ \gamma \frac{v}{2N} (\cos \phi (g(l+1) + g(l)) + \alpha \sin \phi (h(l+1) + h(l))) \right\} d\phi$$

with

$$g_{k,1}^I(l) = \theta_{k,1}^{II}, \quad h_{k,1}^I(l) = \theta_{k,1}^{QI}, \quad \alpha_1^I = \tan \theta$$

$$g_{k,2}^I(l) = \theta_{k,1}^{II}, \quad h_{k,2}^I(l) = \widehat{\theta}_{k,1}^{QI}, \quad \alpha_2^I = -\tan \theta$$

$$g_{k,3}^I(l) = \theta_{k,1}^{II}, \quad h_{k,3}^I(l) = \widehat{\theta}_{k,1}^{QI}, \quad \alpha_3^I = \tan \theta$$

$$g_{k,4}^I(l) = \theta_{k,1}^{II}, \quad h_{k,4}^I(l) = \theta_{k,1}^{QI}, \quad \alpha_4^I = -\tan \theta$$

$$g_{k,5}^I(l) = \widehat{\theta}_{k,1}^{II}, \quad h_{k,5}^I(l) = \theta_{k,1}^{QI}, \quad \alpha_5^I = -\tan \theta$$

$$g_{k,6}^I(l) = \widehat{\theta}_{k,1}^{II}, \quad h_{k,6}^I(l) = \widehat{\theta}_{k,1}^{QI}, \quad \alpha_6^I = \tan \theta$$

$$g_{k,7}^I(l) = \widehat{\theta}_{k,1}^{II}, \quad h_{k,7}^I(l) = \widehat{\theta}_{k,1}^{QI}, \quad \alpha_7^I = -\tan \theta$$

$$g_{k,8}^I(l) = \widehat{\theta}_{k,1}^{II}, \quad h_{k,8}^I(l) = \theta_{k,1}^{QI}, \quad \alpha_8^I = \tan \theta$$

Similarly, we have

$$\Phi_{I_1^Q}(v) = \prod_{k=2}^K \Phi_{I_{k,1}^Q}(v)$$

where

$$\Phi_{I_{k,1}^Q}(v) = \frac{1}{8N} \sum_{l=0}^{N-1} \sum_{i=1}^8 f\left(v; l, g_{k,i}^Q(l), h_{k,i}^Q(l), \alpha_i^Q, \frac{A_k}{A_1}\right)$$

and

$$g_{k,1}^Q(l) = \theta_{k,1}^{QQ}, \quad h_{k,1}^Q(l) = \theta_{k,1}^{IQ}, \quad \alpha_1^Q = -\cot \theta$$

$$g_{k,2}^Q(l) = \theta_{k,1}^{QQ}, \quad h_{k,2}^Q(l) = \hat{\theta}_{k,1}^{IQ}, \quad \alpha_2^Q = \cot \theta$$

$$g_{k,3}^Q(l) = \theta_{k,1}^{QQ}, \quad h_{k,3}^Q(l) = \hat{\theta}_{k,1}^{IQ}, \quad \alpha_3^Q = -\cot \theta$$

$$g_{k,4}^Q(l) = \theta_{k,1}^{QQ}, \quad h_{k,4}^Q(l) = \theta_{k,1}^{IQ}, \quad \alpha_4^Q = \cot \theta$$

$$g_{k,5}^Q(l) = \hat{\theta}_{k,1}^{QQ}, \quad h_{k,5}^Q(l) = \theta_{k,1}^{IQ}, \quad \alpha_5^Q = \cot \theta$$

$$g_{k,6}^Q(l) = \hat{\theta}_{k,1}^{QQ}, \quad h_{k,6}^Q(l) = \hat{\theta}_{k,1}^{IQ}, \quad \alpha_6^Q = -\cot \theta$$

$$g_{k,7}^Q(l) = \hat{\theta}_{k,1}^{QQ}, \quad h_{k,7}^Q(l) = \hat{\theta}_{k,1}^{IQ}, \quad \alpha_7^Q = \cot \theta$$

$$g_{k,8}^Q(l) = \hat{\theta}_{k,1}^{QQ}, \quad h_{k,8}^Q(l) = \theta_{k,1}^{IQ}, \quad \alpha_8^Q = -\cot \theta$$

B. Numerical Examples

Here we show some numerical examples. To see the near–far effect on the error probability, we consider the cases where there are five users in the system and the desired user’s power is four times the power of the interferers, while the interferers have the same power—that is, $P_1 = 4P_2 = 4P_3 = 4P_4 = 4P_5$. Here the total interference power is the same as P_1 . We compare it with the case when there are two users having the same power, i.e., $P_1 = P_2$. In this case also, the total interference power is P_1 .

Figure 6 shows the average probability of error for both the I and Q channels with $\beta = \pi/8$ and $N = 127$. Due to the unequal error protection for the I and Q channels by the modulation scheme, we can see that the I channel has much lower error probability than that of the Q channel.

Figures 7 and 8 show the average error probability for the I and Q channels for the two cases when $\theta = \pi/8$ and $N = 127$. As can be seen, in the case with the near–far effect, the performance is better as SNR increases. This is because even though the total interference power is the same, the effect of each

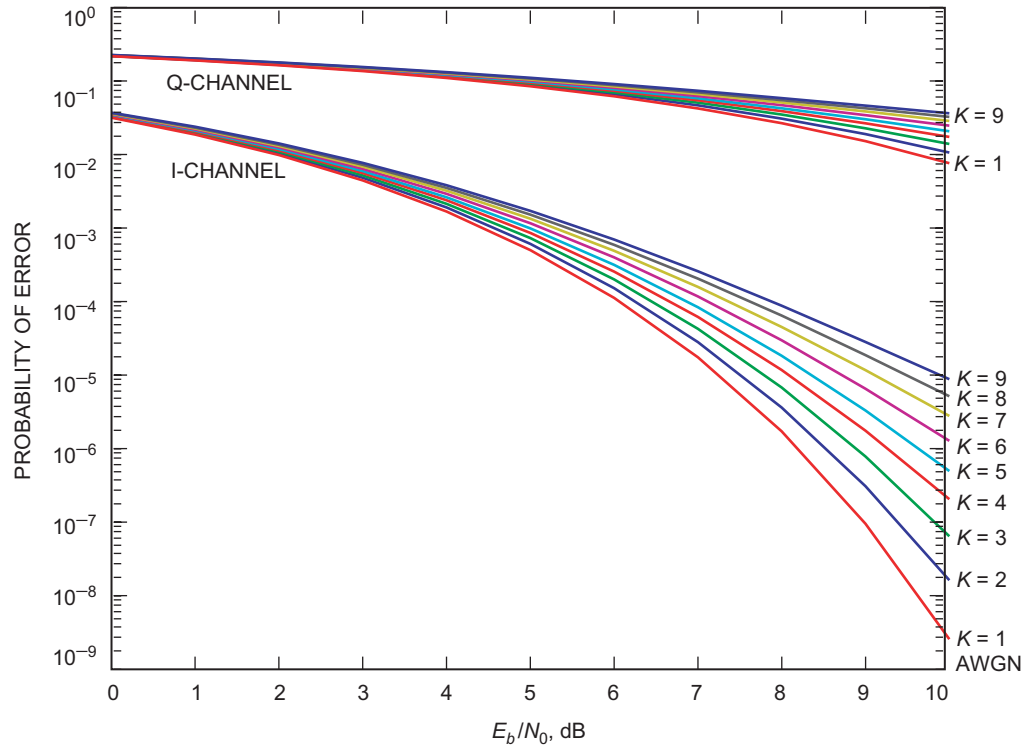

Fig. 6. Probability of error for asymmetric QPSK DS-CDMA ($N = 127$, $\beta = \pi/8$).

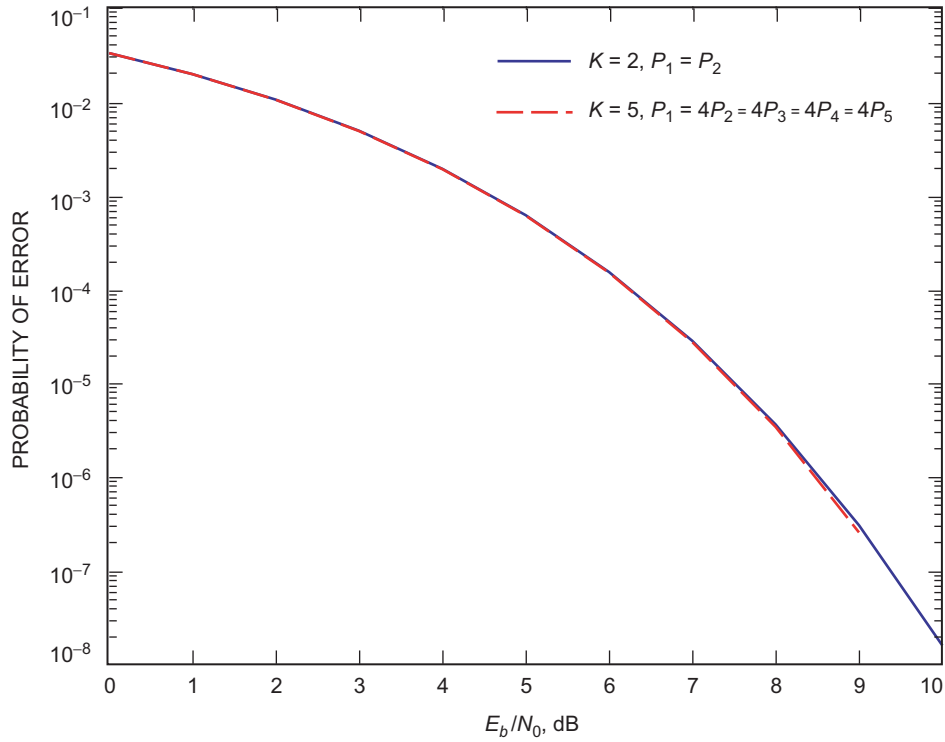

Fig. 7. Probability of error for asymmetric QPSK DS-CDMA I-channel ($N = 127$, $\beta = \pi/8$).

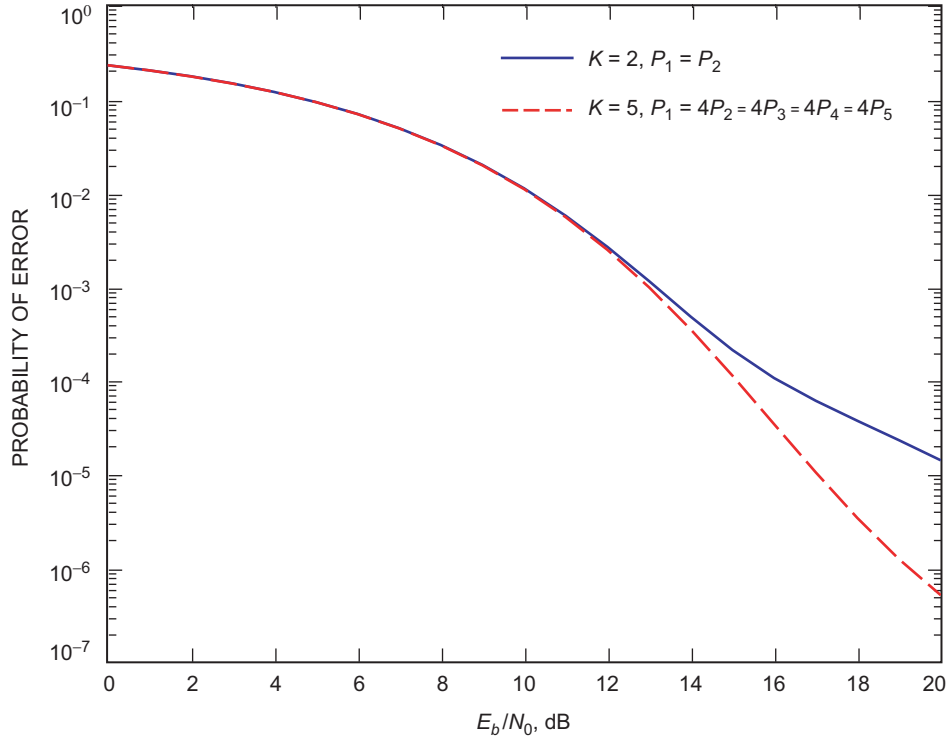

Fig. 8. Probability of error for asymmetric QPSK DS-CDMA Q-channel
($N = 127$, $\beta = \pi/8$).

interferer on the desired user is not the same due to the different correlation relations of the spreading codes. In this case, the interference effect is not four times that of any one interferer since it is unlikely that all interferers' spreading codes have simultaneously large correlation with the desired user.

VI. Conclusions

In this article, the exact and an approximate BER performance were derived for a quaternary asymmetric QPSK DS-CDMA system. The variance and pdf of the MAI were analyzed. The results showed that the AQPSK scheme can provide a significant difference in the amount of error protection for different bits of a symbol. Therefore, it is advantageous to use AQPSK when designing a UEP system for its simplicity and efficiency. We also examined the near-far problem by generalizing the system model to the case where users have different transmit power. The results showed that the Q-channel (less power) is more sensitive to the near-far effect than the I-channel is in a multiple-access environment.

References

- [1] S. M. Alamouti and S. Kallel, "Adaptive Trellis-Coded Multiple-Phase-Shift Keying for Rayleigh Fading Channels," *IEEE Trans. Commun.*, vol. 42, no. 6, pp. 2305–2314, June 1994.
- [2] E. A. Geraniotis and M. B. Pursley, "Error Probability for Direct-Sequence Spread-Spectrum Multiple-Access Communications—Part II: Approximations," *IEEE Trans. Commun.*, vol. 30, no. 5, pp. 985–995, May 1982.

- [3] A. Goldsmith, "Adaptive Modulation and Coding for Fading Channels," *Proceedings of the 1999 IEEE Information Theory and Communications Workshop*, pp. 24–26, June 1999.
- [4] A. J. Goldsmith and S. Chua, "Adaptive Coded Modulation for Fading Channels," *IEEE Trans. Commun.*, vol. 46, no. 5, pp. 595–602, May 1998.
- [5] J. F. Hayes, *Adaptive Feedback Communications*, IEEE Trans. Commun., vol. COM-16, no. 1, pp. 29–34, February 1968.
- [6] M. M. Khairy and E. Geraniotis, "Asymmetric Modulation and Multistage Coding for Multicasting with Multi-Level Reception over Fading Channels," *Proc. 1999 IEEE Military Commun. Conf.*, vol. 1, pp. 92–96, November 1999.
- [7] J. S. Lehnert and M. B. Pursley, "Error Probabilities for Binary Direct-Sequence Spread-Spectrum Communications with Random Signature Sequences," *IEEE Trans. Commun.*, vol. 35, no. 1, pp. 87–98, January 1987.
- [8] J. H. Park and C. W. Lee, "Asymmetric 8-PSK Modulation with Embedded BPSK," *IEEE Electronic Letters*, vol. 30, no. 17, pp. 1376–1378, August 1994.
- [9] M. B. Pursley, "Spread-Spectrum Multiple-Access Communications," *Multi-user Communication Systems*, G. Longo, ed., New York: Springer-Verlag, pp. 139–199, 1981.
- [10] M. B. Pursley and H. F. A. Roefs, "Numerical Evaluation of Correlation Parameters for Optimal Phases of Binary Shift-Register Sequences," *IEEE Trans. Commun.*, vol. 27, no. 10, pp. 1597–1604, October 1979.
- [11] M. B. Pursley and J. M. Shea, "Phase-Shift-Key Modulation for Multimedia Multicast Transmission in Mobile Wireless Networks," *Proc. 1996 IEEE Military Commun. Conf.*, vol. 1, pp. 210–214, October 1996.
- [12] M. B. Pursley and J. M. Shea, "Convolutionally Encoded Phase-Shift-Key Modulation for Multimedia Multicast Transmission in Mobile Wireless Networks," *Proc. 1997 IEEE Military Commun. Conf.*, vol. 2, pp. 978–982, November 1997.
- [13] M. B. Pursley and J. M. Shea, "Multicast Transmission with Nonuniform Phase-Shift-Key Modulation and Convolutional Coding over Rayleigh Fading Channels," *Proc. 1999 IEEE Military Commun. Conf.*, vol. 1, pp. 306–310, November 1999.
- [14] M. B. Pursley and J. M. Shea, "Multimedia Multicast Wireless Communications with Phase-Shift-Key Modulation and Convolutional Coding," *IEEE J. Select. Areas Commun.*, vol. 17, no. 11, pp. 1999–2010, November 1999.
- [15] M. B. Pursley and J. M. Shea, "Nonuniform Phase-Shift-Key Modulation for Multimedia Multicast Transmission in Mobile Wireless Networks," *IEEE J. Select. Areas Commun.*, vol. 17, no. 5, pp. 774–783, May 1999.
- [16] M. B. Pursley and J. M. Shea, "Adaptive Nonuniform Phase-Shift-Key Modulation for Multimedia Traffic in Wireless Networks," *IEEE J. Select. Areas Commun.*, vol. 18, no. 8, pp. 1394–1407, August 2000.
- [17] R. K. Morrow, Jr., and J. S. Lehnert, "Bit-to-Bit Error Dependence in Slotted DS/CDMA Packet Systems with Random Signature Sequences," *IEEE Trans. Commun.*, vol. 37, no. 10, pp. 1052–1061, October 1989.
- [18] M. Sajadieh, F. R. Kschischang, and A. Leon-Garcia, "Modulation-Assisted Unequal Error Protection over the Fading Channel," *IEEE Trans. Veh. Technol.*, vol. 47, no. 3, pp. 900–908, August 1998.

- [19] S. Vishwanath and A. Goldsmith, "Adaptive Turbo-Coded Modulation for Flat-Fading Channels," *IEEE Trans. Commun.*, vol. 51, no. 6, pp. 964–972, June 2003.
- [20] L. F. Wei, "Coded Modulation with Unequal Error Protection," *IEEE Trans. Commun.*, vol. 41, no. 10, pp. 1439–1449, October 1993.

Appendix A

Characteristic Function of I_I

To further simplify Eq. (10), we have

$$\Phi_{I_I}(v) = \prod_{k=2}^K \left\{ \frac{1}{32\pi T} \sum_{l=0}^{N-1} \int_0^{2\pi} \int_0^T \sum_{\underline{b}_k^I} \sum_{\underline{b}_k^Q} \exp \left[jv \frac{1}{T} (\Delta) \right] d\tau d\phi \right\}$$

where

$$\begin{aligned} \Delta = & \left[\cos \phi (b_{k,-1}^I C_{k,1}^{II}(l-N) + b_{k,0}^I C_{k,1}^{II}(l)) \right. \\ & \left. + \tan \beta \cdot \sin \phi (b_{k,-1}^Q C_{k,1}^{QI}(l-N) + b_{k,0}^Q C_{k,1}^{QI}(l)) \right] \cdot \widehat{R}_\psi(\tau) \\ & + \left[\cos \phi (b_{k,-1}^I C_{k,1}^{II}(l+1-N) + b_{k,0}^I C_{k,1}^{II}(l+1)) \right. \\ & \left. + \tan \beta \cdot \sin \phi (b_{k,-1}^Q C_{k,1}^{QI}(l+1-N) + b_{k,0}^Q C_{k,1}^{QI}(l+1)) \right] \cdot R_\psi(\tau) \end{aligned}$$

To evaluate the summations over \underline{b}_k^I and \underline{b}_k^Q , we note that there are 16 cases for $(\underline{b}_k^I, \underline{b}_k^Q) = (b_{k,-1}^I, b_{k,0}^I, b_{k,-1}^Q, b_{k,0}^Q)$ as in Table A-1.

Introducing the periodic cross-correlation functions

$$\theta_{k,i}^{II}(l) = C_{k,i}^{II}(l) + C_{k,i}^{II}(l-N)$$

$$\widehat{\theta}_{k,i}^{II}(l) = C_{k,i}^{II}(l) - C_{k,i}^{II}(l-N)$$

$$\theta_{k,i}^{QI}(l) = C_{k,i}^{QI}(l) + C_{k,i}^{QI}(l-N)$$

$$\widehat{\theta}_{k,i}^{QI}(l) = C_{k,i}^{QI}(l) - C_{k,i}^{QI}(l-N)$$

we evaluate Δ for the above 16 cases with the following results.

Table A-1. Sixteen cases for $(\underline{b}_k^I, \underline{b}_k^Q)$.

Case	$b_{k,-1}^I$	$b_{k,0}^I$	$b_{k,-1}^Q$	$b_{k,0}^Q$
1	1	1	1	1
2	1	1	1	-1
3	1	1	-1	1
4	1	1	-1	-1
5	1	-1	1	1
6	1	-1	1	-1
7	1	-1	-1	1
8	1	-1	-1	-1
9	-1	1	1	1
10	-1	1	1	-1
11	-1	1	-1	1
12	-1	1	-1	-1
13	-1	-1	1	1
14	-1	-1	1	-1
15	-1	-1	-1	1
16	-1	-1	-1	-1

Case 1:

$$\begin{aligned} \Delta_1 = & \left[\cos \phi \cdot \theta_{k,1}^{II}(l) + \tan \beta \cdot \sin \phi \cdot \theta_{k,1}^{QI}(l) \right] \widehat{R}_\psi(\tau) \\ & + \left[\cos \phi \cdot \theta_{k,1}^{II}(l+1) + \tan \beta \cdot \sin \phi \cdot \theta_{k,1}^{QI}(l+1) \right] R_\psi(\tau) \end{aligned}$$

Case 2:

$$\begin{aligned} \Delta_2 = & \left[\cos \phi \cdot \theta_{k,1}^{II}(l) - \tan \beta \cdot \sin \phi \cdot \widehat{\theta}_{k,1}^{QI}(l) \right] \widehat{R}_\psi(\tau) \\ & + \left[\cos \phi \cdot \theta_{k,1}^{II}(l+1) - \tan \beta \cdot \sin \phi \cdot \widehat{\theta}_{k,1}^{QI}(l+1) \right] R_\psi(\tau) \end{aligned}$$

Case 3:

$$\begin{aligned} \Delta_3 = & \left[\cos \phi \cdot \theta_{k,1}^{II}(l) + \tan \beta \cdot \sin \phi \cdot \widehat{\theta}_{k,1}^{QI}(l) \right] \widehat{R}_\psi(\tau) \\ & + \left[\cos \phi \cdot \theta_{k,1}^{II}(l+1) + \tan \beta \cdot \sin \phi \cdot \widehat{\theta}_{k,1}^{QI}(l+1) \right] R_\psi(\tau) \end{aligned}$$

Case 4:

$$\begin{aligned}\Delta_4 &= \left[\cos \phi \cdot \theta_{k,1}^{II}(l) - \tan \beta \cdot \sin \phi \cdot \theta_{k,1}^{QI}(l) \right] \widehat{R}_\psi(\tau) \\ &\quad + \left[\cos \phi \cdot \theta_{k,1}^{II}(l+1) - \tan \beta \cdot \sin \phi \cdot \theta_{k,1}^{QI}(l+1) \right] R_\psi(\tau)\end{aligned}$$

Case 5:

$$\begin{aligned}\Delta_5 &= - \left(\left[\cos \phi \cdot \widehat{\theta}_{k,1}^{II}(l) - \tan \beta \cdot \sin \phi \cdot \theta_{k,1}^{QI}(l) \right] \widehat{R}_\psi(\tau) \right. \\ &\quad \left. + \left[\cos \phi \cdot \widehat{\theta}_{k,1}^{II}(l+1) - \tan \beta \cdot \sin \phi \cdot \theta_{k,1}^{QI}(l+1) \right] R_\psi(\tau) \right)\end{aligned}$$

Case 6:

$$\begin{aligned}\Delta_6 &= - \left(\left[\cos \phi \cdot \widehat{\theta}_{k,1}^{II}(l) + \tan \beta \cdot \sin \phi \cdot \widehat{\theta}_{k,1}^{QI}(l) \right] \widehat{R}_\psi(\tau) \right. \\ &\quad \left. + \left[\cos \phi \cdot \widehat{\theta}_{k,1}^{II}(l+1) + \tan \beta \cdot \sin \phi \cdot \widehat{\theta}_{k,1}^{QI}(l+1) \right] R_\psi(\tau) \right)\end{aligned}$$

Case 7:

$$\begin{aligned}\Delta_7 &= - \left(\left[\cos \phi \cdot \widehat{\theta}_{k,1}^{II}(l) - \tan \beta \cdot \sin \phi \cdot \widehat{\theta}_{k,1}^{QI}(l) \right] \widehat{R}_\psi(\tau) \right. \\ &\quad \left. + \left[\cos \phi \cdot \widehat{\theta}_{k,1}^{II}(l+1) - \tan \beta \cdot \sin \phi \cdot \widehat{\theta}_{k,1}^{QI}(l+1) \right] R_\psi(\tau) \right)\end{aligned}$$

Case 8:

$$\begin{aligned}\Delta_8 &= - \left(\left[\cos \phi \cdot \widehat{\theta}_{k,1}^{II}(l) + \tan \beta \cdot \sin \phi \cdot \theta_{k,1}^{QI}(l) \right] \widehat{R}_\psi(\tau) \right. \\ &\quad \left. + \left[\cos \phi \cdot \widehat{\theta}_{k,1}^{II}(l+1) + \tan \beta \cdot \sin \phi \cdot \theta_{k,1}^{QI}(l+1) \right] R_\psi(\tau) \right)\end{aligned}$$

The latter 8 cases are simply the negative of the first 8 and thus we have 8 pairs of cases. For case 1 and case 16, we have

$$\exp\left(jv\frac{1}{T}\Delta_1\right) + \exp\left(jv\frac{1}{T}\Delta_{16}\right) = e^{jv(\Delta_1/T)} + e^{-jv(\Delta_1/T)} = 2\cos\left(\frac{v}{T}\Delta_1\right)$$

with similar results for the other pairs of cases. Therefore, we have

$$\Phi_{I_l}(v) = \prod_{k=2}^K \left\{ \frac{1}{8N} \sum_{l=0}^{N-1} \left(\sum_{i=1}^8 \frac{1}{2\pi T_c} \int_0^{2\pi} \int_0^{T_c} \cos\left(\frac{v}{T}\Delta_i\right) \right) \right\}$$

If we further define

$$f(v; l, g(l), h(l), \alpha) \triangleq \frac{1}{2\pi T_c} \int_0^{2\pi} \int_0^{T_c} \cos \left\{ \frac{v}{T} \left[(\cos \phi \cdot g(l) + \alpha \sin \phi \cdot h(l)) \widehat{R}_\psi(\tau) \right. \right. \\ \left. \left. + (\cos \phi \cdot g(l+1) + \alpha \sin \phi \cdot h(l+1)) R_\psi(\tau) \right] \right\} d\tau d\phi$$

then the characteristic function can be written as

$$\Phi_{I_I}(v) = \prod_{k=2}^K \left\{ \frac{1}{8N} \sum_{l=0}^{N-1} \left(\sum_{i=1}^8 f(v; l, g_i(l), h_i(l), \alpha_i) \right) \right\}$$

where

$$g_1(l) = \theta_{k,1}^{II}, h_1(l) = \theta_{k,1}^{QI}, \alpha_1 = \tan \beta$$

$$g_2(l) = \theta_{k,1}^{II}, h_2(l) = \widehat{\theta}_{k,1}^{QI}, \alpha_2 = -\tan \beta$$

$$g_3(l) = \theta_{k,1}^{II}, h_3(l) = \widehat{\theta}_{k,1}^{QI}, \alpha_3 = \tan \beta$$

$$g_4(l) = \theta_{k,1}^{II}, h_4(l) = \theta_{k,1}^{QI}, \alpha_4 = -\tan \beta$$

$$g_5(l) = \widehat{\theta}_{k,1}^{II}, h_5(l) = \theta_{k,1}^{QI}, \alpha_5 = -\tan \beta$$

$$g_6(l) = \widehat{\theta}_{k,1}^{II}, h_6(l) = \widehat{\theta}_{k,1}^{QI}, \alpha_6 = \tan \beta$$

$$g_7(l) = \widehat{\theta}_{k,1}^{II}, h_7(l) = \widehat{\theta}_{k,1}^{QI}, \alpha_7 = -\tan \beta$$

$$g_8(l) = \widehat{\theta}_{k,1}^{II}, h_8(l) = \theta_{k,1}^{QI}, \alpha_8 = \tan \beta$$

As can be seen, in order to evaluate the characteristic function, we need to evaluate $f(v; l, g(l), h(l), \alpha)$, which involves the computation of double integrals that can be complicated. We can further simplify this by integrating over τ when considering the chip waveform $\psi(t)$ to be the rectangular pulse. In this case, $\widehat{R}_\psi(\tau) = T_c - \tau$ and $R_\psi(\tau) = \tau$. Now the integrand can be written as

$$\begin{aligned}
E &= \cos \left\{ \frac{v}{T} \left[(\cos \phi \cdot g(l) + \alpha \sin \phi \cdot h(l)) \widehat{R}_\psi(\tau) + (\cos \phi \cdot g(l+1) + \alpha \sin \phi \cdot h(l+1)) R_\psi(\tau) \right] \right\} \\
&= \cos \left\{ \frac{v}{T} \left[(\cos \phi \cdot g(l) + \alpha \sin \phi \cdot h(l))(T_c - \tau) + (\cos \phi \cdot g(l+1) + \alpha \sin \phi \cdot h(l+1))\tau \right] \right\} \\
&= \cos \left\{ \frac{v}{T} \left[\cos \phi \left((g(l+1) - g(l))\tau + g(l)T_c \right) + \alpha \sin \phi \left((h(l+1) - h(l))\tau + h(l)T_c \right) \right] \right\} \\
&= \cos \left\{ \frac{v}{T} \left[\left(\cos \phi (g(l+1) - g(l)) + \alpha \sin \phi (h(l+1) - h(l)) \right) \tau + \left(\cos \phi g(l) + \alpha \sin \phi h(l) \right) T_c \right] \right\} \\
&= \cos (F\tau + G)
\end{aligned}$$

where

$$F = \frac{v}{T} (\cos \phi (g(l+1) - g(l)) + \alpha \sin \phi (h(l+1) - h(l)))$$

and

$$G = \frac{v}{T} (\cos \phi g(l) + \alpha \sin \phi h(l)) T_c$$

Next, we integrate E over τ to obtain

$$\begin{aligned}
\frac{1}{T_c} \int_0^{T_c} \cos (F\tau + G) d\tau &= \frac{1}{FT_c} \sin (F\tau + G) \Big|_0^{T_c} \\
&= \frac{1}{FT_c} \left\{ \sin (FT_c + G) - \sin (G) \right\} \\
&= \frac{1}{FT_c} \left\{ 2 \sin \left(\frac{1}{2} FT_c \right) \cos \left(\frac{1}{2} FT_c + G \right) \right\} \\
&= \text{sinc} \left(\frac{1}{2\pi} FT_c \right) \cos \left(\frac{1}{2} FT_c + G \right)
\end{aligned}$$

where

$$\text{sinc}(x) = \frac{\sin(\pi x)}{\pi x}$$

$$\begin{aligned}
\frac{1}{2\pi} FT_c &= \frac{1}{2\pi} \frac{v}{T} \left(\cos \phi (g(l+1) - g(l)) + \alpha \sin \phi (h(l+1) - h(l)) \right) T_c \\
&= \frac{v}{2\pi N} \left(\cos \phi (g(l+1) - g(l)) + \alpha \sin \phi (h(l+1) - h(l)) \right)
\end{aligned}$$

and

$$\begin{aligned}
\frac{1}{2}FT_c + G &= \frac{v}{2N} \left(\cos \phi(g(l+1) - g(l)) + \alpha \sin \phi(h(l+1) - h(l)) \right) \\
&\quad + \frac{v}{T} \left(\cos \phi h_1(l) + \alpha \sin \phi h_2(l) \right) T_c \\
&= \frac{v}{2N} \left(\cos \phi(g(l+1) + g(l)) + \alpha \sin \phi(h(l+1) + h(l)) \right)
\end{aligned}$$

Therefore, we have

$$\begin{aligned}
f(v; l, g(l), h(l), \alpha) &= \frac{1}{2\pi} \int_0^{2\pi} \text{sinc} \left\{ \frac{v}{2\pi N} \left(\cos \phi(g(l+1) - g(l)) + \alpha \sin \phi(h(l+1) - h(l)) \right) \right\} \\
&\quad \cdot \cos \left\{ \frac{v}{2N} \left(\cos \phi(g(l+1) + g(l)) + \alpha \sin \phi(h(l+1) + h(l)) \right) \right\} d\phi
\end{aligned}$$

Appendix B

Variance of the Interference

The derivation here follows the work in [7]. According to Eqs. (6) and (7), we can expand Eq. (11) as

$$\begin{aligned}
W_k^{II} &= [b_{k,-1}^I \cdot C_{k,1}^{II}(\gamma_k - N) + b_{k,0}^I \cdot C_{k,1}^{II}(\gamma_k)] \widehat{R}_\psi(S_k) \\
&\quad + [b_{k,-1}^I \cdot C_{k,1}^{II}(\gamma_k + 1 - N) + b_{k,0}^I \cdot C_{k,1}^{II}(\gamma_k + 1)] R_\psi(S_k)
\end{aligned} \tag{B-1}$$

where $S_k = \tau_k - \gamma_k T_c$ and $\gamma_k = \lfloor \tau_k / T_c \rfloor$. If we use Eq. (8) to expand Eq. (B-1), we obtain

$$\begin{aligned}
W_k^{II} &= \left[\sum_{j=0}^{\gamma_k-1} b_{k,-1}^I a_{k,j-\gamma_k+N}^I a_{1,j}^I + \sum_{j=\gamma_k}^{N-1} b_{k,0}^I a_{k,j-\gamma_k}^I a_{1,j}^I \right] \widehat{R}_\psi(S_k) \\
&\quad + \left[\sum_{j=0}^{\gamma_k} b_{k,-1}^I a_{k,j-\gamma_k-1+N}^I a_{1,j}^I + \sum_{j=\gamma_k+1}^{N-1} b_{k,0}^I a_{k,j-\gamma_k-1}^I a_{1,j}^I \right] R_\psi(S_k)
\end{aligned} \tag{B-2}$$

which can be further expanded to obtain

$$\begin{aligned}
W_k^{II} = & \left[\sum_{j=0}^{\gamma_k-1} b_{k,-1}^I a_{k,j-\gamma_k+N}^I a_{1,j}^I + \sum_{j=\gamma_k}^{N-2} b_{k,0}^I a_{k,j-\gamma_k}^I a_{1,j}^I + b_{k,0}^I a_{k,N-\gamma_k-1}^I a_{1,N-1}^I \right] \widehat{R}_\psi(S_k) \\
& + \left[b_{k,-1}^I a_{k,N-\gamma_k-1}^I a_{1,0}^I + \sum_{j=0}^{\gamma_k-1} b_{k,-1}^I a_{k,j-\gamma_k+N}^I a_{1,j+1}^I + \sum_{j=\gamma_k}^{N-2} b_{k,0}^I a_{k,j-\gamma_k}^I a_{1,j+1}^I \right] R_\psi(S_k) \quad (\text{B-3})
\end{aligned}$$

Finally, the terms in Eq. (B-3) can be rearranged to obtain

$$\begin{aligned}
W_k^{II} = & b_{k,-1}^I \sum_{j=0}^{\gamma_k-1} a_{k,j-\gamma_k+N}^I \left(a_{1,j}^I \widehat{R}_\psi(S_k) + a_{1,j+1}^I R_\psi(S_k) \right) \\
& + b_{k,0}^I \sum_{j=\gamma_k}^{N-2} a_{k,j-\gamma_k}^I \left(a_{1,j}^I \widehat{R}_\psi(S_k) + a_{1,j+1}^I R_\psi(S_k) \right) \\
& + b_{k,0}^I a_{k,N-\gamma_k-1}^I a_{1,N-1}^I \widehat{R}_\psi(S_k) + b_{k,-1}^I a_{k,N-\gamma_k-1}^I a_{1,0}^I R_\psi(S_k) \quad (\text{B-4})
\end{aligned}$$

In order to reduce the complexity of evaluating Eq. (B-4), we consider it conditioned on the signature sequence of the first user $\{a_{1,j}^I\}$ and the random variable γ_k , which is uniformly distributed on the set $\{0, \dots, N-1\}$. We condition on $\gamma_k = \hat{\gamma}_k$ and $\{a_{1,j}^I\} = \{\hat{a}_{1,j}^I\}$, and define a set of $N+1$ random variables Ω_j , $0 \leq j \leq N$, by

$$\Omega_j = \begin{cases} b_{k,-1}^I a_{k,j-\hat{\gamma}_k+N}^I \hat{a}_{1,j}^I, & j = 0, \dots, \hat{\gamma}_k - 1 \\ b_{k,0}^I a_{k,j-\hat{\gamma}_k}^I \hat{a}_{1,j}^I, & j = \hat{\gamma}_k, \dots, N-2 \\ b_{k,0}^I a_{k,N-\hat{\gamma}_k-1}^I \hat{a}_{1,N-1}^I, & j = N-1 \\ b_{k,-1}^I a_{k,N-\hat{\gamma}_k-1}^I \hat{a}_{1,0}^I, & j = N \end{cases}$$

Then Eq. (B-4) can be simplified to

$$W_k^{II} = \sum_{j=0}^{N-2} \Omega_j \left[\widehat{R}_\psi(S_k) + \hat{a}_{1,j}^I \hat{a}_{1,j+1}^I R_\psi(S_k) \right] + \Omega_{N-1} \widehat{R}_\psi(S_k) + \Omega_N R_\psi(S_k) \quad (\text{B-5})$$

where the random variables Ω_j , $0 \leq j \leq N$, are mutually independent and satisfy $\Pr(\Omega_j = +1) = \Pr(\Omega_j = -1) = 1/2$. If we further define $f(s) = \widehat{R}_\psi(s) + R_\psi(s)$, $g(s) = \widehat{R}_\psi(s) - R_\psi(s)$, the set Γ_1 to be the set of all nonnegative integers i less than $N-1$ such that $\hat{a}_{1,i}^I \hat{a}_{1,i+1}^I = 1$ and the set Γ_2 to be the set of all nonnegative integers i less than $N-1$ such that $\hat{a}_{1,i}^I \hat{a}_{1,i+1}^I = -1$, then Eq. (B-5) can be written as

$$W_k^{II} = \sum_{j \in \Gamma_1} \Omega_j f(S_k) + \sum_{j \in \Gamma_2} \Omega_j g(S_k) + \Omega_{N-1} \widehat{R}_\psi(S_k) + \Omega_N R_\psi(S_k)$$

If we let $X_k^{II} = \sum_{j \in \Gamma_1} \Omega_j$, $Y_k^{II} = \sum_{j \in \Gamma_2} \Omega_j$, $\Pi_k^{II} = \Omega_{N-1}$, and $\Lambda_k^{II} = \Omega_N$, then we have

$$W_k^{II} = \Pi_k^{II} \widehat{R}_\psi(S_k) + \Lambda_k^{II} R_\psi(S_k) + X_k^{II} f(S_k) + Y_k^{II} g(S_k)$$

Similarly, W_k^{QI} can be written as

$$W_k^{QI} = \Pi_k^{QI} \widehat{R}_\psi(S_k) + \Lambda_k^{QI} R_\psi(S_k) + X_k^{QI} f(S_k) + Y_k^{QI} g(S_k)$$

with Π_k^{QI} , Λ_k^{QI} , X_k^{QI} , and Y_k^{QI} defined in a similar way.

At this point, in order to simplify the notation, we ignore the superscript of W_k , Π_k , Λ_k , X_k , and Y_k . The random variables Π_k and Λ_k are uniform on $\{-1, 1\}$, and X_k and Y_k have pdfs

$$p_{X_k}(i) = \binom{L}{\frac{i+L}{2}} 2^{-L}, \quad i \in \{-L, -L+2, \dots, L-2, L\}$$

$$p_{Y_k}(i) = \binom{M}{\frac{i+M}{2}} 2^{-M}, \quad i \in \{-M, -M+2, \dots, M-2, M\}$$

where $L = (N-1+U)/2$, $M = (N-1-U)/2$. The random variable U is defined as

$$U = \sum_{j=0}^{N-2} a_{1,j} \cdot a_{1,j+1}$$

where $\{a_{1,j}\}$ is the signature sequence of user 1. By assuming random signature sequences, the pdf of U is given by

$$p_U(i) = \binom{N-1}{\frac{i+N-1}{2}} 2^{-N+1}, \quad i \in \{-N+2, -N+3, \dots, N-3, N-1\}$$

If $\psi(t)$ is a rectangular pulse, we have

$$W_k = \Pi_k S_k + \Lambda_k (T_c - S_k) + X_k T_c + Y_k (T_c - 2S_k)$$

Let $\mathbf{S} = (S_1, \dots, S_K)$ and $\Phi = (\phi_1, \dots, \phi_K)$. Then the conditional variance of W^I is given by

$$\begin{aligned} \text{Var}[W | \mathbf{S}, \Phi, M] &= E \left[\left(\sqrt{P/2} \cdot \cos \beta \sum_{k=2}^K W_k \cdot \cos \phi_k \right)^2 \mid \mathbf{S}, \Phi, M \right] \\ &= \frac{P}{2} \cos^2 \beta \sum_{k=2}^K E[W_k^2 | S_k, M] \cdot E[\cos^2 \phi_k | \phi_k] \\ &= \frac{P}{2} \cos^2 \beta \sum_{k=2}^K \frac{1}{2} [1 + \cos(2\phi_k)] \cdot \text{Var}[W_k | S_k, M] \end{aligned} \quad (\text{B-6})$$

The conditional variance of W_k can be computed as

$$\text{Var}[W_k | S_k, M] = E[\Pi_k^2 S_k^2 | S_k] + E[\Lambda_k^2 (T_c - S_k)^2 | S_k] + E[X_k^2 T_c^2 | M] + E[Y_k^2 (T_c - 2S_k)^2 | S_k, M] \quad (\text{B-7})$$

The random variables Π_k and Λ_k have variances equal to 1. Then we have

$$E[\Pi_k^2 S_k^2 | S_k] = S_k^2 \quad (\text{B-8})$$

$$E[\Lambda_k^2 (T_c - S_k)^2 | S_k] = (T_c - S_k)^2 \quad (\text{B-9})$$

$$E[X_k^2 T_c^2 | M] = T_c^2 (N - M - 1) \quad (\text{B-10})$$

$$E[Y_k^2 (T_c - 2S_k)^2 | S_k, M] = M(T_c - 2S_k)^2 \quad (\text{B-11})$$

Substituting Eqs. (B-8) through (B-11) in Eq. (B-7) gives

$$\text{Var}[W_k | S_k, M] = 2(2M + 1)(S_k^2 - T_c S_k) + NT_c^2$$

and thus from Eq. (B-6),

$$\begin{aligned} \text{Var}[W | \mathbf{S}, \Phi, M] &= \frac{P}{2} \cos^2 \beta \sum_{k=2}^K \frac{1}{2} [1 + \cos(2\phi_k)] [2(2M + 1)(S_k^2 - T_c S_k) + NT_c^2] \\ &= \frac{P}{2} \cos^2 \beta \sum_{k=2}^K [1 + \cos(2\phi_k)] \left[(2M + 1)(S_k^2 - T_c S_k) + \frac{NT_c^2}{2} \right] \end{aligned}$$

By averaging over ϕ_k ,

$$\begin{aligned} \text{Var}[W | \mathbf{S}, M] &= \frac{P}{2} \cos^2 \beta \sum_{k=2}^K \left[(2M + 1)(S_k^2 - T_c S_k) + \frac{NT_c^2}{2} \right] \\ &= \frac{P}{2} \cos^2 \beta \left[\sum_{k=2}^K (2M + 1)(S_k^2 - T_c S_k) \right] + \frac{(K - 1)NPT_c^2}{4} \cos^2 \beta \end{aligned}$$

By averaging over S_k , since $E[S_k^2 - T_c S_k] = -T_c^2/6$, we have

$$\text{Var}[W | M] = \frac{(K - 1)NPT_c^2}{4} \cos^2 \beta - \frac{PT_c^2}{12} \cos^2 \beta \sum_{k=2}^K (2M + 1)$$

For random signature sequences, $E[M] = (N - 1)/2$; thus, we have

$$\begin{aligned}\text{Var}[W] &= \frac{(K - 1)NPT_c^2}{4} \cos^2 \beta - \frac{PT_c^2}{12} \cos^2 \beta \sum_{k=2}^K \left(2\frac{N - 1}{2} + 1 \right) \\ &= \frac{(K - 1)NPT_c^2 \cos^2 \beta}{6}\end{aligned}$$

Therefore, the variance of W^I is given by

$$\text{Var}[W^I] = \frac{(K - 1)NPT_c^2 \cos^2 \beta}{6}$$

Similarly, it can be shown that

$$\text{Var}[W^Q] = \frac{(K - 1)NPT_c^2 \sin^2 \beta}{6}$$