

BRUSH SEALS FOR IMPROVED STEAM TURBINE PERFORMANCE

Norman Turnquist and Ray Chupp
GE Global Research
Niskayuna, New York

Fred Baily, Mark Burnett, and Flor Rivas
GE Energy
Schenectady, New York

Aaron Bowsher and Peter Crudgington
Cross Manufacturing
Devizes, United Kingdom

Brush Seals for Improved Steam Turbine Performance

*NASA Seals Workshop
November 08-09, 2005*

Norman Turnquist, Ray Chupp – GE Global Research, Niskayuna, NY
Fred Baily, Mark Burnett, Flor Rivas – GE Energy, Schenectady, NY
Aaron Bowsher, Peter Crudgington – Cross Manufacturing, Devizes, UK

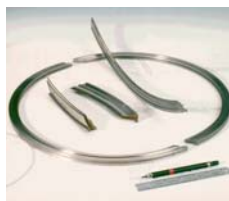

Copyright General Electric Company. NASA has been granted permission to publish and disseminate this work as a part of the NASA Seal/Secondary Air System Workshop proceedings. All other rights retained by the copyright owner.

GE Energy has retrofitted brush seals into more than 19 operating steam turbines. Brush seals offer superior leakage control compared to labyrinth seals, owing to their compliant nature and ability to maintain very tight clearances to the rotating shaft. Seal designs have been established for steam turbines ranging in size from 12 MW to over 1200 MW, including fossil, nuclear, combined-cycle and industrial applications.

Steam turbines present unique design challenges that must be addressed to ensure that the potential performance benefits of brush seals are realized. Brush seals can have important effects on the overall turbine system that must be taken into account to assure reliable operation. Subscale rig tests are instrumental to understanding seal behavior under simulated steam-turbine operating conditions, prior to installing brush seals in the field. This presentation discusses the technical challenges of designing brush seals for steam turbines; subscale testing; performance benefits of brush seals; overall system effects; and field applications.

Brush Seals for Improved Steam Turbine Performance

- **Steam Turbine Applications**
- **Performance Benefits**
- **Seal Design Parameters**
- **System Considerations**
- **Laboratory Testing**
- **Field Experience**
- **Summary**

Copyright General Electric Company. NASA has been granted permission to publish and disseminate this work as a part of the NASA Seal/Secondary Air System Workshop proceedings. All other rights retained by the copyright owner.

Outline of presentation

Brush Seal Locations – Shaft Seals

Allowable number of brush seals determined by Rotordynamic evaluation.

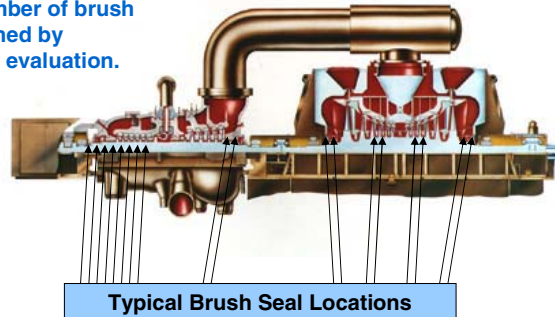

Brush Seals at LP rotor ends reduce Steam Seal System needs; seals at HP/IP rotor ends reduce supply leakage.

Brush Seals at selected HP and LP interstage locations further improve heat rate.

Copyright General Electric Company. NASA has been granted permission to publish and disseminate this work as a part of the NASA Seal/Secondary Air System Workshop proceedings. All other rights retained by the copyright owner.

Brush seals applied to maximize performance benefit.

-Typically interstage locations of High Pressure Section

-Low Pressure section interstage as well

-Also end packings to prevent end leakage (some steam leakage from HP end seals is used to seal LP ends, so LP ends must be sealed as well)

-Total permissible number of seals per rotor is evaluated from standpoint of rotordynamics

Performance Benefits

Typical Sources of Steam Turbine Stage Efficiency Loss

Sealing accounts for nearly 1/3 of total turbine stage efficiency loss.

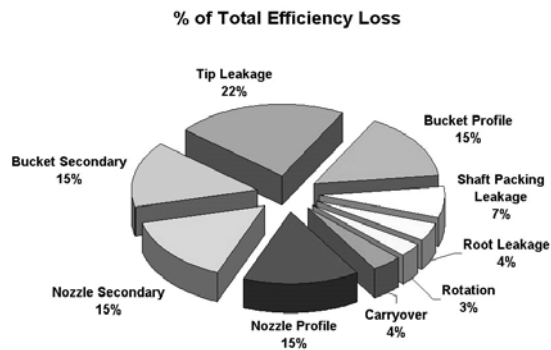

Copyright General Electric Company. NASA has been granted permission to publish and disseminate this work as a part of the NASA Seal/Secondary Air System Workshop proceedings. All other rights retained by the copyright owner.

Sealing accounts for roughly 1/3 of total stage efficiency loss in a steam turbine.

Pressure Drop Capability

- **Decreased Backing Plate Clearance**
 - Improves ΔP Capability
 - But Increases Risk of Rotor Rubs
- **Increased Backing Plate Clearance**
 - Bristles Deform at Inner Diameter
 - Leads to Increased Steam Leakage

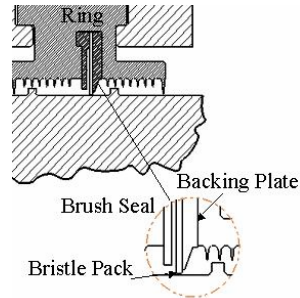

Pressure drop capability of Brush Seals exceeds 2.7 MPa (400 psid); 4.1 MPa (>600 psid for seals in series).

Copyright General Electric Company. NASA has been granted permission to publish and disseminate this work as a part of the NASA Seal/Secondary Air System Workshop proceedings. All other rights retained by the copyright owner.

Typical pressure drop across interstage seal is 100-400 psid.

End packing seals typically up to 600 psid.

Can be up to 2000 psid at inlet end of ST; GE is developing compliant seals to handle this.

Seals Test Rigs at Cross Manufacturing

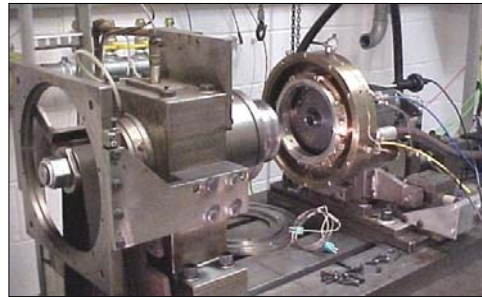
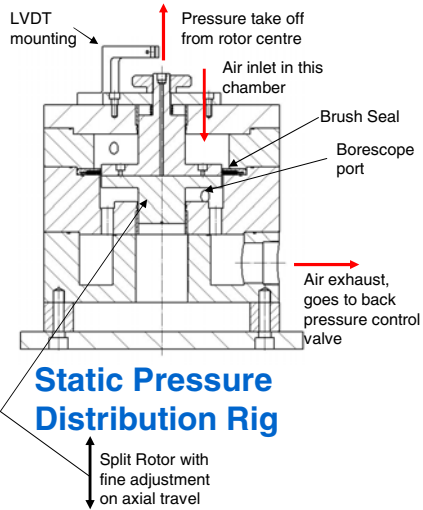

Ambient Dynamic Rig

Ambient dynamic rig capability:

Maximum Pressure = 1.8 MPa (260 psia)

Maximum speed = 20,000 rev/min

Maximum surface speed = 136 m/s (444 ft/s)

Axial displacement capability

Radial displacement capability

Copyright General Electric Company. NASA has been granted permission to publish and disseminate this work as a part of the NASA Seal/Secondary Air System Workshop proceedings. All other rights retained by the copyright owner.

Subscale testing has been conducted jointly between GE and Cross Mfg. in the UK.

Cross' two subscale rigs are used to perform screening tests on new seal designs, evaluating leakage behavior, wear, and robustness.

Seals Test Rig at GE Global Research

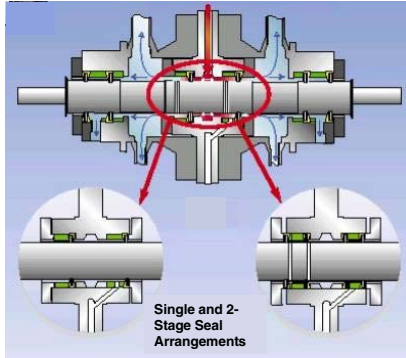

Test for:

- Leakage
- Durability / pressure capability
- Seal / rotor wear
- Seal hysteresis
- Rotor dynamics

Rig Capabilities:

- Steam at up to 8.3 MPa (1200 psi); 400 °C (750°F)
- Air at up to 3.1 MPa (450 psi), 540°C (1000°F)
- Rotor surface speeds up to 245 m/s (800 ft/s)
- CrMoV rotor on tilting-pad bearings
- Stepped rotor allows wear/hysteresis testing

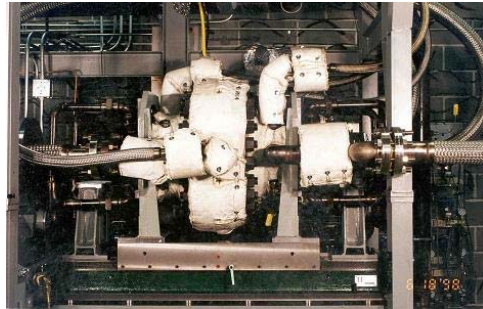

Copyright General Electric Company. NASA has been granted permission to publish and disseminate this work as a part of the NASA Seal/Secondary Air System Workshop proceedings. All other rights retained by the copyright owner.

GE GRC Rig capable of testing in 1200 psi, 750 F Steam
or 450 psi, 1000 F Air

Capable of 800 ft/s surface speed (36000 RPM).

5.1” shaft supported on tilting pad journal bearings; can be run above 1st and 2nd critical speeds to evaluate rotordynamics.

Rig is used for leakage and wear testing of ST, GT, and AE brush and labyrinth seals.

Seal Leakage Performance

Brush Seal Effective Clearance generally less than 1/3 that of Labyrinth Seals

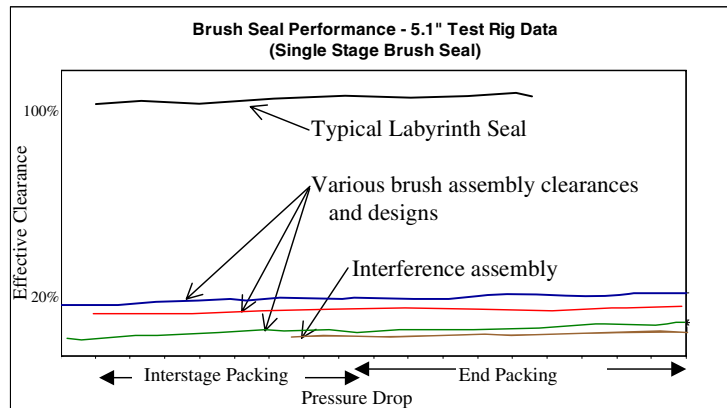

Copyright General Electric Company. NASA has been granted permission to publish and disseminate this work as a part of the NASA Seal/Secondary Air System Workshop proceedings. All other rights retained by the copyright owner.

Various brush seal arrangements tested over pressure ranges typical of steam turbine interstage seals.

Even with assembly clearance, brush seal leakage is typically $<1/3$ that of a conventional labyrinth seal.

Rotor Dynamic Response

Seal design, clearance, and location influence Rotor Dynamics.

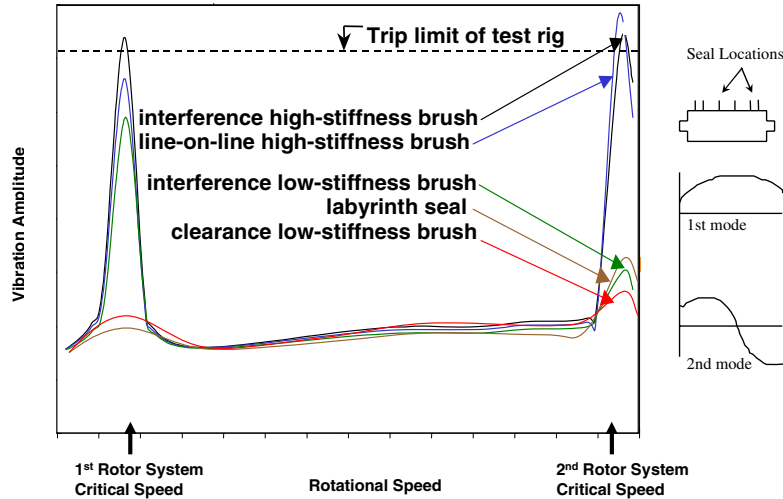

Copyright General Electric Company. NASA has been granted permission to publish and disseminate this work as a part of the NASA Seal/Secondary Air System Workshop proceedings. All other rights retained by the copyright owner.

Steam Turbine solid, flexible shaft is sensitive to rub-induced heating and possibility of resultant rotor ‘bow’, which results in rotor vibrations.

Seals concentrated near rotor midspan affect rotor during startup (passing through critical speed). Seals near rotor ends tend to affect rotor at speeds just below 2nd critical speed. (ST’s typically run between the 1st and 2nd critical speeds.

Impact on rotordynamic response is reduced with increasing assembly clearance.

Brush seals assembled with clearance; blowdown results in minimal contact of bristles to rotor, but significant performance improvement.

Rotordynamics & Turbine Operation

- **Contacting Seals at Midspan**
 - **Influence Behavior Below 1st Bending Critical Speed**
 - **Start-Up Affected**
- **Contacting Seals at Rotor Ends**
 - **Influence Behavior Below 2nd Critical Speed**
 - **Stability at Running Speed Affected**
- **Design Methodology Developed**
 - **Relates Several Rotordynamic System Parameters**
 - **Determines Acceptable Number of Seals to Apply**

**Turbine Can Be Started and Operated Normally with
NO SPECIAL CONSIDERATIONS**

Copyright General Electric Company. NASA has been granted permission to publish and disseminate this work as a part of the NASA Seal/Secondary Air System Workshop proceedings. All other rights retained by the copyright owner.

Rotordynamics is a very important consideration in how many seals are applied, at which locations, and with what level of assembly clearance/interference.

GE has developed a tool to assess rotordynamic impact; validated through lab testing and field experience.

Brush seals are applied in GE steam turbines with no added constraints on turbine operability.

Bristle / Rotor Wear

- Brush Seals Contact the Rotor during machine transients
- Optimum bristle material is temperature-dependent, and is determined via sliding and rotational wear testing
 - Haynes® 25 for $T > 260^{\circ}\text{C}$ (500°F)
 - Hastelloy® C-276 for $T < 260^{\circ}\text{C}$ (500°F)
- No rotor coating required

® - Haynes International

Typical Brush Seal and Rotor Surface
after Wear Testing on GRC Rig



Copyright General Electric Company. NASA has been granted permission to publish and disseminate this work as a part of the NASA Seal/Secondary Air System Workshop proceedings. All other rights retained by the copyright owner.

Haynes 25 is standard bristle material for ST applications $>500^{\circ}\text{F}$

Hastelloy C276 is standard bristle material for ST applications $<500^{\circ}\text{F}$

Temperatures typically range from 500-1050 F in high pressure turbine section, $<500^{\circ}\text{F}$ in low pressure section.

Used on uncoated CrMoV rotor.

Bristle Stability

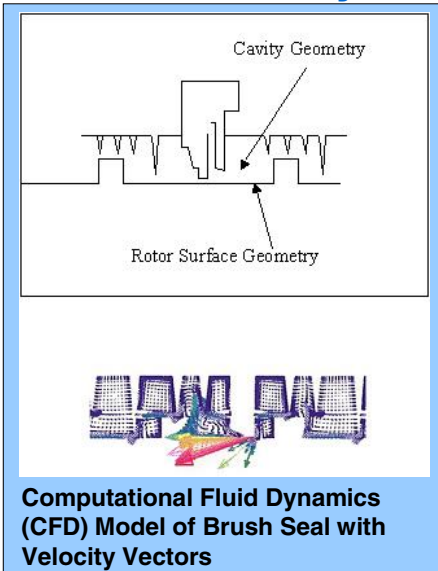

Computational Fluid Dynamics (CFD) Model of Brush Seal with Velocity Vectors

Copyright General Electric Company. NASA has been granted permission to publish and disseminate this work as a part of the NASA Seal/Secondary Air System Workshop proceedings. All other rights retained by the copyright owner.

- **Bristle Stability affected by:**
 - Inlet swirl
 - Steam density
 - Seal pressure drop
 - Cavity / rotor geometry
 - Seal (bristle) stiffness
- **Bristle instability can lead to high cycle fatigue of bristles and/or abnormal bristle pack wear**
- **Bristle stiffness must be carefully selected to balance stability concerns with frictional heating, wear issues**

Bristle aerodynamic stability is an important design consideration.

Steam Turbine Test Vehicle

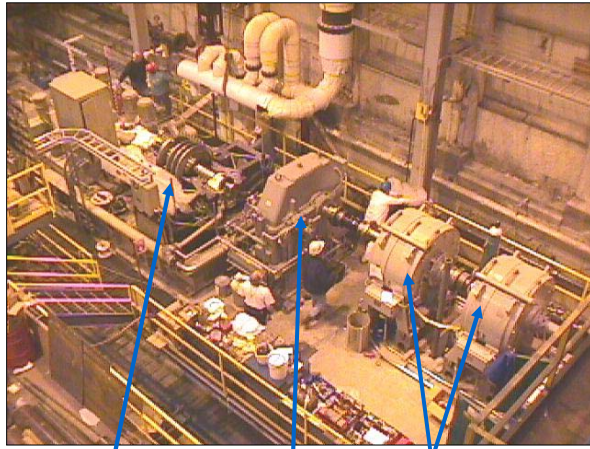

Turbine

Gearbox

Water Brakes

- 3.5 MW Boiler Feed-Pump Turbine
- Steam path modified to mimic thermodynamic design of a utility steam turbine
- Interstage and Bucket Tip Brush Seals tested
- 1% Efficiency improvement measured for brush seals

Copyright General Electric Company. NASA has been granted permission to publish and disseminate this work as a part of the NASA Seal/Secondary Air System Workshop proceedings. All other rights retained by the copyright owner.

Fully Instrumented Test Vehicle Allows for Pressures, Temperatures to be Measured at Discrete Radial Positions at each stage.

Velocity profiles at specified locations measured.

Back to back performance testing with brush seals in a STEAM ENVIRONMENT validates predictive methods.

Field Experience

- 85 MW HP Section
- 250 MW Opposed Flow High Pressure/Intermediate Pressure Section
- 700 MW HP Sections
- 900 MW HP Sections
- 1000 MW Nuclear Turbine
- Brush Seals applied at Hp End Packings, Interstage, and Bucket Tips

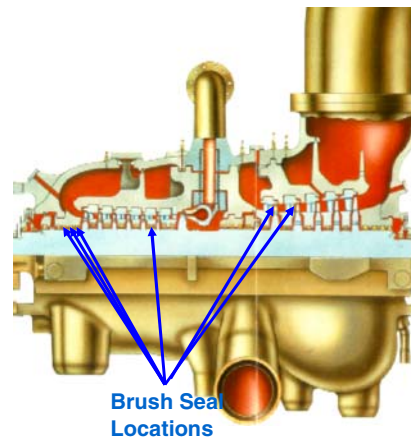

250 MW HP/IP Section

Copyright General Electric Company. NASA has been granted permission to publish and disseminate this work as a part of the NASA Seal/Secondary Air System Workshop proceedings. All other rights retained by the copyright owner.

Approx. 20 machines in the field with approximately 200 brush seals.

Fleet leader has eight years of service.

Inspection Results - HP Shaft Seals

Seals inspected after 17 months of service.
Seals found in excellent condition and returned to service.



Polished rotor surface at brush seal locations.

Copyright General Electric Company. NASA has been granted permission to publish and disseminate this work as a part of the NASA Seal/Secondary Air System Workshop proceedings. All other rights retained by the copyright owner.

End packing seals (3 brushes shown).

Polishing of rotor surface.

Minimal brush wear observed.

Inspection Results - HP Shaft Seals

**250 MW End Packing
– After 17 months**



**700 MW Stage 6 –
After 3 years**

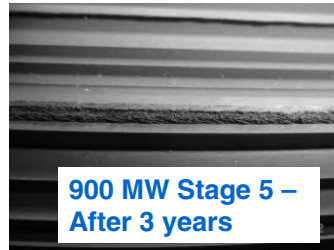

**900 MW Stage 5 –
After 3 years**

Shaft seal durability established.

Copyright General Electric Company. NASA has been granted permission to publish and disseminate this work as a part of the NASA Seal/Secondary Air System Workshop proceedings. All other rights retained by the copyright owner.

Note the polished rotor. Not only in this view, but throughout the circumference, the bristles survived. Bristle density is good and clearance (no wear) maintained. These were reinstalled after the outage.

Inspection Results - HP Shaft Seals

*85 MW Steam Turbine interstage
shaft seals after 8 years of service*



Long term shaft seal durability established.

Copyright General Electric Company. NASA has been granted permission to publish and disseminate this work as a part of the NASA Seal/Secondary Air System Workshop proceedings. All other rights retained by the copyright owner.

Most recent inspection results.

85 MW power generation turbine; 8 interstage seals in high pressure steam interstage locations.

8 years of service; approximately 30 startups.

Polished rotor at all seal locations.

Polished bristle tips around seal circumference at all seal locations.

Seals performing as intended after 8 years of service.

Bucket Tip Seals / Integral Cover Buckets

- **250 MW unit - Seal installed adjacent to integral cover buckets of second IP stage**
- **Overall seal integrity is good after 17 months; seal returned to service**
- **Some stray bristles at seal segment ends; segment end design improved**
- **New bucket cover designs eliminate radial inflow/outflow, allowing wider use of brush seals**

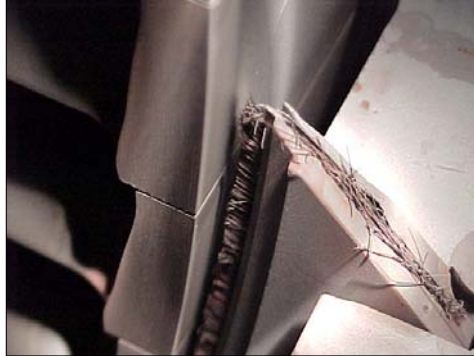

Copyright General Electric Company. NASA has been granted permission to publish and disseminate this work as a part of the NASA Seal/Secondary Air System Workshop proceedings. All other rights retained by the copyright owner.

Tip seal in this unit looked very good. This end segment is slightly gnarled at the end, but along the circumference, the bristles survived. Note that over bucket tips, gaps between cover sections or radial steps at the junction of adjacent cover sections are important design considerations.

Further work underway to improve robustness of bucket tip brush seals.

Brush Seal Quality



- Consistent bristle angle control of a production class GE Steam Brush Seal.

- Bristle angle control is essential to achieving the expected seal performance (Leakage, Wear, etc.).

- Consistent bristle density (packing) of a production class GE Steam Brush Seal.

- Pack consistency is essential for the seal to operate at the design pressure drop.

- Bristle tips are free, not fused or hooked together.

- Having the bristle tips free ensures consistent seal stiffness and seal behaviour.

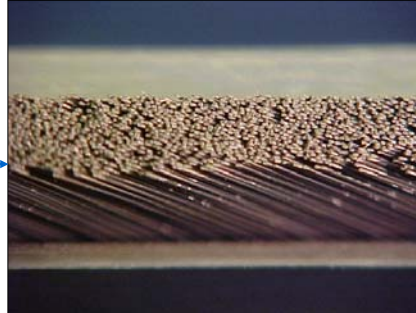

Copyright General Electric Company. NASA has been granted permission to publish and disseminate this work as a part of the NASA Seal/Secondary Air System Workshop proceedings. All other rights retained by the copyright owner.

Brush seal quality is crucial to achieving intended seal stiffness and leakage performance, and for ensuring that the seals do not adversely affect turbine operation (rotor heating, rotordynamics, rotor thrust, leakage, etc.).

Patents

- Flower, R.F.J., "Brush Seals", US Patent No. 5090710
- Flower, R.F.J., "Sealing Device", US Patent No. 5474305
- Turnquist, N.A., et. al. "Combined Labyrinth and Brush Seals for Rotary Machines," US Patent No. 6045134
- Turnquist, N.A., et. al., "Steam Turbine Having Brush Seal Assembly," US Patent No. 6053699
- Turnquist, N.A., et. al., "Combined Labyrinth and Brush Seals for Rotary Machines," US Patent No. 6105967
- Bagepalli, B.S., et. al., "Brush Seals and Combined Labyrinth and Brush Seals for Rotary Machines," US Patent No. 6131910
- Turnquist, N.A., et. al., "Method for Overhauling a Steam Turbine to Increase Its Power," US Patent No. 6260269
- Turnquist, N.A., et. al., "Arrangement and Method for Radially Positioning a Turbine Brush Seal," US Patent No. 6308958
- Crudgington, P.F., "Cavity Brush Seal", US Patent No. 6772482
- Crudgington, P.F., and Bowsher, A., "Brush Seal Element", US Patent No. 6799766

Copyright General Electric Company. NASA has been granted permission to publish and disseminate this work as a part of the NASA Seal/Secondary Air System Workshop proceedings. All other rights retained by the copyright owner.

Cross (the seal vendor), and GE (the turbine OEM) have several patents on brush seals and their application to steam turbines.

Summary

Brush Seals are an effective means of improving steam turbine efficiency.

- **Brush seals provide significant performance benefit in Overall Heat Rate due to reduced leakage rates for utility steam turbines (actual benefit is application-specific).**
- **Brush seal design characteristics are well understood.**
- **Consideration of the turbine as a system is important for the full performance benefit of brush seals to be realized.**
- **Analytical predictions and extensive lab testing have been verified with field experience.**
- **Brush seal quality is essential to maximizing performance benefit.**
- **Joint development between seal vendor and turbine manufacturer has led to several patents.**

Copyright General Electric Company. NASA has been granted permission to publish and disseminate this work as a part of the NASA Seal/Secondary Air System Workshop proceedings. All other rights retained by the copyright owner.

Conclusions