

Gossamer Technology to Deorbit LEO Non-Propulsion Fitted Satellite

C. Dupuy* and O. Le Couls**

Abstract

Since 2004, CNES has decided to apply the end of life Code of Conduct rules to debris mitigation. Originally drawn up by the main European space agencies, it contains basic rules to be applied in space in order to limit the increase of orbital debris. In low Earth orbit, the rule is to limit in-orbit lifetime to 25 years after the end of the operational mission, or else to transfer to a graveyard orbit above 2000 km. In order to follow these instructions, a task force was set up in 2005 to find the best way to implement them on MICROSCOPE and CNES microsatellite family (MYRIADE). This 200-kg spacecraft should be launched in 2014 on a 790-km high circular orbit. Without targeted action, its natural re-entry would occur in 67 years.

Two strategies to reduce this time period were compared: propulsive maneuvers at the end of the mission or the deployment of large surfaces to increase significantly the ballistic coefficient. At the end of the trade off, it was recommended:

- For the non-propulsive system fitted satellites, to use passive aerobraking by deployment of added surface,
- For satellites having propulsive subsystem in baseline for mission purposes, to keep sufficient propellant and implement specific maneuvers.

The poster gives an overview of the process that led to the development of a deployable aerobraking wing using a lightweight aluminized Kapton membrane and an inflatable aluminum laminate boom.

- The main requirements
- The trade off among various aerobraking solutions
- The development plan

This technology presents a very attractive potential and it could be a first step in using of inflatable technology on spaces vehicles, before to deal with others more exigent applications.



MICROSCOPE, orbital configuration

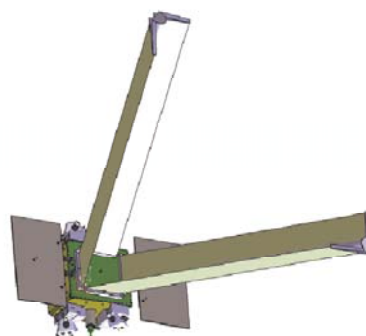

MICROSCOPE, deorbit configuration

Figure 1

* Centre National d'Etudes Spatiales, Toulouse France

** EADS Astrium, Saint Médard en Jalles, France

The MICROSCOPE Spacecraft

MICROSCOPE is based on CNES' MYRIADE micro-satellite product line which started in 1998. Its scientific objective is to test the Equivalence Principle with an accuracy of 10⁻¹⁵, about three orders of magnitude better than the accuracy of the present on ground experiments. The space mission exploits the Earth as the gravitational source, the very quiet in orbit environment and the possibility of a very long free fall motion for the integration of the measurement.

The T-SAGE instrument is composed of two differential electrostatic accelerometers (see Figure 2). Each one includes two cylindrical and concentric test masses. The attitude, as well as the atmospheric and thermal drag of the satellite, are actively controlled in such a way that the satellite follows the two test masses in their pure gravitational motion. The test-mass motions, within the highly stable silica instrument frame, are also servo-controlled using very accurate capacitive position sensing and electrostatic actuators. The relative position of the two masses is thus maintained motionless and the fine measurement of the control force leads to the test of the Equivalence Principle with the expected 10⁻¹⁵ accuracy. The mission is obviously extremely sensitive to microperturbations such as structural micro-cracking and fluid motions. It was apparent very early in the design that no liquid propulsion system could be envisaged. The satellite drag compensation and attitude control involves a specific propulsion system. For the first time, FEEP thrusters have been chosen but due to technical problems a cold gas solution is now being investigated. The satellite will be on a sun-synchronous polar orbit at 790-km altitude with an ascending node at 6 h or 18 h. This leads to a nominal orbit where natural re-entry would take place in 67 years (see Figure 3). At 200 kg, MICROSCOPE is heavier than common MYRIADE satellites. Its general architecture also presents several particularities:

- the payload is in the middle of the spacecraft,
- the body is wider (870 x 790 section instead of 600 x 600),
- the solar array is based on two symmetrical single-panel wings instead of the standard MYRIADE two-panel wing solar array.



Figure 2: T-SAGE instrument

De-Orbiting MICROSCOPE: Options and Constraints

The dominant factor of orbit erosion is the atmospheric drag, which depends linearly on the surface to mass ratio (S/m) of a given spacecraft. The deceleration due to drag can be written as:

$\gamma = \frac{1}{2} \rho S/m C_d V^2$, where:

- ρ is the local atmospheric density,
- C_d is the coefficient of drag, in practice between 2 and 3, assumed to be equal to 2.6 in the rest of this study,
- V is the orbital velocity.

The surface S is the cross section perpendicular to the velocity vector (see figure 5). After the end of its operational life, the attitude of the satellite will not be controlled. Since for most of the decay phase (above 650 km) there is no obvious natural self-pointing, we consider that all altitudes would be equally

likely. The **average apparent surface** of MICROSCOPE is evaluated at 2.7 m^2 . With a mass of 200 kg, this leads to :

$$S/m = 0.0135 \text{ m}^2/\text{kg}.$$

With the DTM94 atmospheric model, using the Codior software, which is a semi-analytical tool for long term extrapolations developed by SERGA for CNES for sun-synchronous or low orbits, we find that MICROSCOPE's natural re-entry would occur 67 years after decommissioning (see Figure 3), which is assumed to take place on January 1 2017.

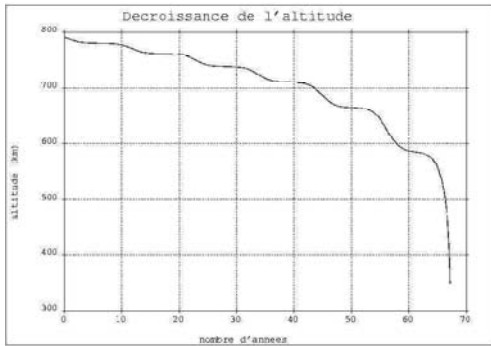

Figure 3: MICROSCOPE's orbital decay without special maneuver

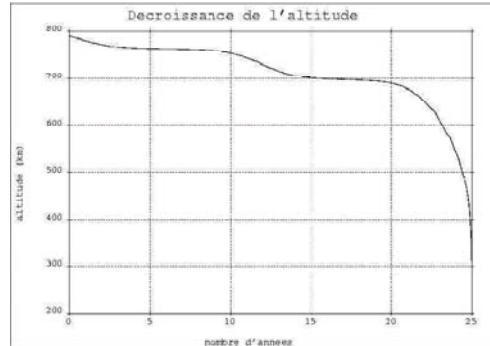

Figure 4: MICROSCOPE's orbital decay with 6-m^2 drag area

Since MICROSCOPE is below 800 km, the Code of Conduct option to transfer it to a graveyard orbit higher than 2000 km at the end of its life does not seem feasible within the mass and volume allowed for the spacecraft. We will therefore focus our efforts on ensuring that re-entry will occur in less than 25 years after the mission's end. Considering its relatively small mass, uncontrolled re-entry is acceptable. Two main strategies were identified:

- "Drag raise": increase of natural orbit erosion so that orbital decay from the original orbit will take less than 25 years,
- "Propulsion": maneuver to go down to an orbit where life-time is less than 25 years.

The only option that has been studied in detail for "drag raise" increase, is to deploy surfaces around the spacecraft to raise natural aerodynamic drag. Other concepts could have been involved (deployment of tethers to use magnetic forces for braking), but they were quickly dismissed as impractical for a small satellite. Figure 4 shows that the required 25 years re-entry would occur if the S/m is set to $0.03 \text{ m}^2/\text{kg}$, which calls for a mean drag area of 6 m^2 . This result corresponds to a beginning of de-orbiting at the start of 2017. This means an addition of 3.3 m^2 of drag surface to the operational configuration of MICROSCOPE.

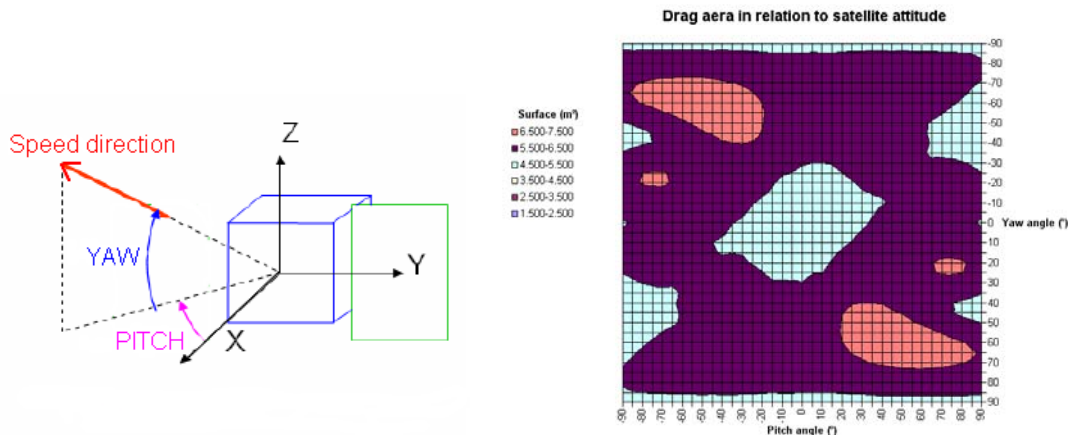
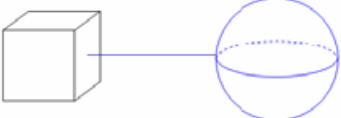
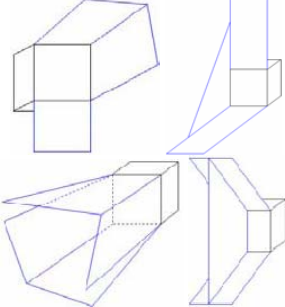
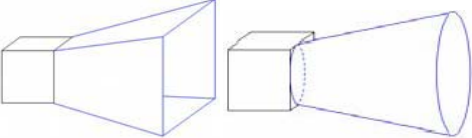

Figure 5: Drag area calculation

Drag Raise: Review of Concepts

To begin with, a target shape for the deployed surfaces was selected. The ideal system would create additional drag homogeneously over all possible attitudes of the spacecraft. In theory, one may try to approach the shape of a sphere.

 <p style="text-align: center;">Sphere Diameter ≥ 2.7 m</p>	<ul style="list-style-type: none"> ☹ Volume > 10 000 liters ☹ Deployed total area > 23 m² ☹ Mass budget > 30 kg ☹ Yoke necessary to link with satellite
 <p style="text-align: center;">Dihedral</p>	<ul style="list-style-type: none"> ☺ easier to accommodate and complement the surface provided by satellite & solar array panels ☺ Mass < 15 kg ☺ Dihedron could be done with serial of flat panel arrangement or with boom associated with deployed membrane film.
 <p style="text-align: center;">Cone</p>	<ul style="list-style-type: none"> ☺ Same advantages than dihedron arrangement ☹ Difficult to provide a perfect cone shape without discontinuities ☹ Not necessary for uncontrolled re-entry

→The dihedral shape was finally chosen!

To build the wings, two families of technologies were quickly identified. The first is based on low weight flat panels. Because of the restrictions on volume in packed configuration, only 2 wings of 3 panels (0,5 m² each) can be accommodated. This only leads to a total mean drag area of 4 m², 2. m² short of the 6. m² target.

Based on sandwich panels with carbon fiber sheets, the total mass of this package including holding and deployment devices has been evaluated at 6 kg. Even though de-orbiting with this system would take around 40 years without margin from the nominal orbit, we disregarded it for the more innovative second solution family.

The second family of technologies is based on unfolded Aluminum / Kapton membranes with deployable structures. Figure 6 describes various concepts that were assessed for deployment.

Technological trade off

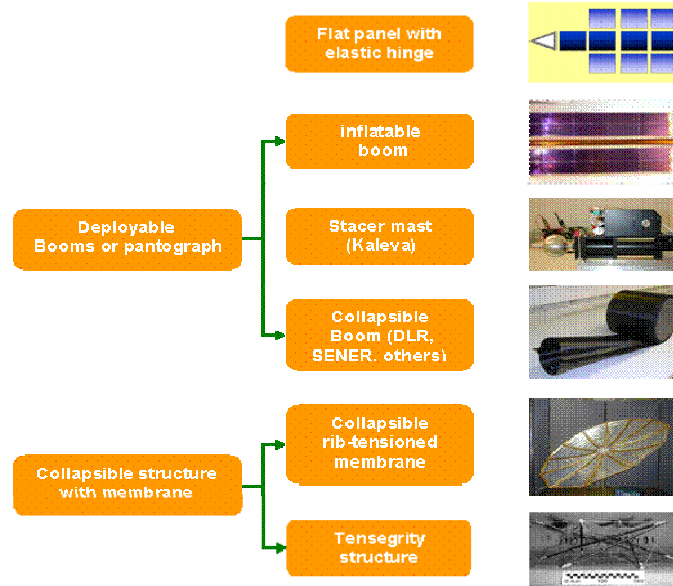

Figure 6: Technological trade off

- **Tensegrity** structures, made from cables and struts to which a state of pre-stress is imposed that imparts tension to all cables. This solution was assessed to be complicated for this type of application, and not easily accessible.
- **Deployable masts** based on multi-coil Stacer tube, such as those used on Demeter. Here, the fact that the mast rotates through deployment is unfavorable.
- **Doubly curved membrane stiffened** by thin-walled collapsible ribs such as the Collapsible Rib Tensioned Surface (CRTS) reflector developed by ESA. Here the packaging and the demonstration that micro-cracking would not happen during the mission, seemed difficult.
- **Bi-stable masts** such as those originally developed by DLR for solar sails, made of two laminated flexible -shaped sheets bonded at the edges to form a tubular shape. The main disadvantage is in their significant mass for a limited (compared to solar sail) area such as in this application,
- **Inflatable mast** made of aluminum laminate. This is the solution that was finally selected because of its light weight and its efficient packaging especially in term of volume. It is presented in more detail. The total mass of two inflatable wings offering 3.7 m² of drag area is 12 kg.

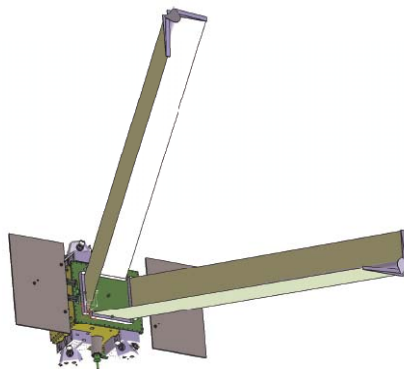

Figure 7: wings with inflatable mast

De-Orbiting Wing Technology

The de-orbiting configuration is shown in Figure 7. Two 5-m-long wings made of aluminized Kapton membrane (100 g/m² density) have been deployed by a central inflatable mast. The actual total mean drag surface becomes 6.7 m².

The total provisional mass, with margin, of a two-wing package is 12 kg (5 kg per wing and 2 kg for the inflation system), including thermal control. The materials have been selected for their endurance to ultraviolet exposition, and to atomic oxygen aggression. They can also cope with high temperatures which are expected when the membrane is in full sun.

IDEAS General Architecture

The IDEAS system is composed of several sub-systems (see Figure 8), each of them ensuring one or several specific functions.

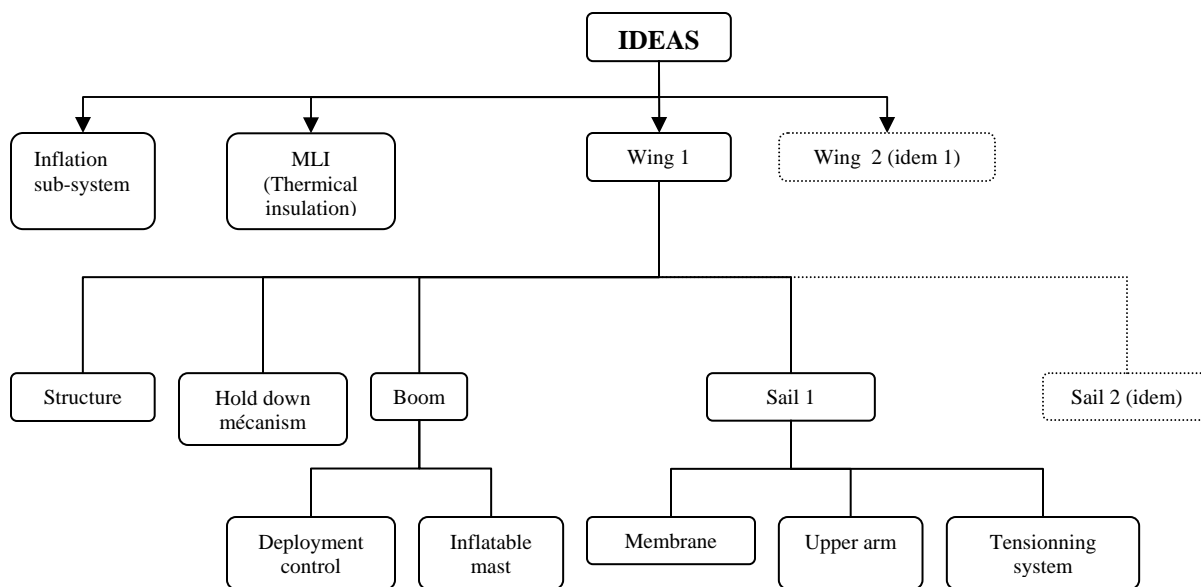

Figure 8: Product tree

The hold down sub-system function is to maintain IDEAS in folded configuration and to ensure the unlocking before deployment. The inflation sub-system function is to ensure the boom deployment and rigidization. It is also ensuring the venting of the boom in folded configuration during launcher phase, and in deployed configuration after rigidization. The MLI (Multi Layer Insulation) sub-system function is to ensure the thermal protection of IDEAS system from the external environment, in stowed configuration. The wing's function is to ensure the deployment of the aerobraking surfaces for IDEAS operating life. The two wings have the same definition and are composed of one boom and two membranes. The boom is ensuring the deployment and the rigidization to maintain the wing in deployed configuration (with inflation sub-system), and the two membranes are ensuring the aerobraking function.

The inflated boom of the selected technological solution has to be rigidized after deployment to ensure a correct mechanical behavior of the deployed surface without maintaining pressure. Several solutions have been analysed:

- solvent evaporation
- Sub-Tg
- thermal polymerisation
- photochemical polymerization
- metallic laminate yielding

The criteria considered are power need, long in-orbit storage consequences (premature rigidization risk) and feasibility complexity. The retained solution is the metallic laminate yielding.

Presentation of the Laminate Technology

The principle of folding, deployment and rigidization of the IDEAS boom is described in the following illustration.

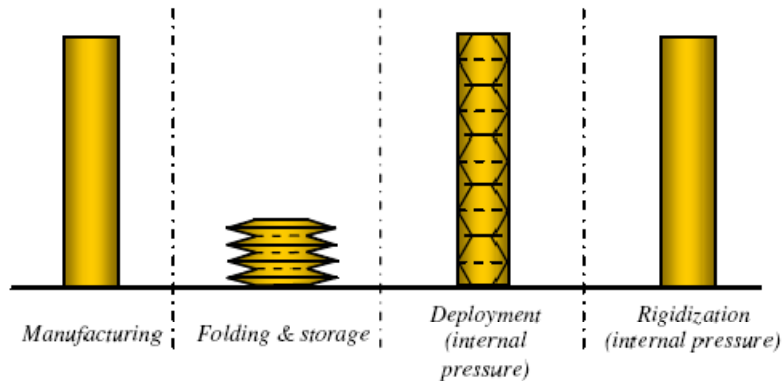

Figure 9: Boom folding, deployment and rigidization concept

The rigidization process chosen, “metallic laminate yielding”, consists of applying to the boom material a sufficient deformation - applied by internal pressure – to suppress geometrical defect created by yielding of the material during folding. Once the defects are suppressed, the mechanical behavior of the boom is ensured by its own stiffness. The boom material used to ensure this function is polyimide/aluminum/polyimide laminate.

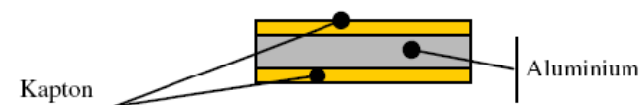

Figure 10: Laminate definition

The aluminum layer ensures the mechanical behavior after rigidization. The Kapton internal layer ensures the protection of the aluminum layer from internal mechanical “aggressions” and the tightness during boom inflation. The kapton external layer ensures the protection of the aluminum layer from external mechanical “aggressions” and has a thermal protection function. The main advantages of this solution are the good material stability during storage phases and the use of the same source of energy as for the deployment (no electrical power is necessary to rigidize).

Laminate aluminum boom technology is useful to in orbit low-stress-loaded structures. For the IDEAS wings at altitude up to 320 km, aerodynamics pressure is estimated below $0.42 \text{ E}^{-3} \text{ Pa}$. This is negligible face to dynamics load due to uncontrolled effect. Spin speed could reach $10 \text{ }^\circ/\text{s}$.

A test campaign has been performed, and demonstrates the good behavior of 1-meter long boom, after deployment and rigidization (2). For a 4,6-meter long boom with 160-mm diameter, the maximum flexure load is 6 Nm and maximum compression load 60 N.



Figure 11: 3-meter wing breadboard

Conclusion

The choice of the passive aerobraking to respect the IADC code of conduct, is validated, for the Myriade microsatellite family without propulsion system. The development of this equipment is linked to the MICROSCOPE project. The deorbiting progress with deployable aerobraking appendage is under CNES patent (3).

In 2007, inflatable aluminum laminate boom and deployable membrane have been tested in microgravity environment during a 0g flight test campaign. A 3-meter wing breadboard has been manufactured and tested on ground by Astrium Space Transportation.

Technological solution for deployment and rigidization are chosen and validations are well advanced. Currently the project is ending of the preliminary design phase and the PDR review is scheduled for the beginning of 2011. The achievement of the de-orbiting sub-system development is foreseen end of 2013, with the delivery of the flight model for MICROSCOPE satellite.

IDEAS project is, more than the development of a product dedicated to MICROSCOPE, the development of a concept and its associated technology that can have other potential others space applications.

References

1. 2007Aluminum laminate technology for micro-satellite Deorbiting aerobrake system“ – O. LE COULS, D. LACOUR (EADS Astrium), C. DUPUY (CNES) – 3rd European Workshop on Inflatable Space Structures, ESTEC, October 12th 2006
2. The innovative deorbiting aerobrake system “IDEAS”: The gossamer technology for Micro-satellite deorbiting – 10th European Conference on Spacecraft Structures, Materials & Mechanical Testing, Berlin 10-13 September
3. Satellite airbrake device Patent n° WO2007096428