

## HIGH-PRECISION TEMPERATURE CONTROL OF A CRYSTAL GROWTH FURNACE AT 1500°C

Ch. Stenzel<sup>1</sup>, A. Hess<sup>2</sup>, A. Cröll<sup>2</sup>, D. Bräuer<sup>3</sup>, H. Sauermann<sup>3</sup>

<sup>1</sup>Astrium GmbH, D-88090 Immenstaad

<sup>2</sup>Kristallographie, Institut für Geowissenschaften, Universität Freiburg, D- 79104 Freiburg

<sup>3</sup>Institut für Automatisierungstechnik, TU Bergakademie Freiberg, D- 09596 Freiberg

Keywords: Temperature control, Crystal growth, High-temperature furnace

### Abstract

For crystal growth of semiconductor materials a short-term temperature stability of 0.1°C at 1500°C is one of the essential parameters to be addressed for achieving high-quality crystals.

Hence, for temperature monitoring and control with high precision in a floating zone furnace two sets of thermo-sensors, type B thermocouples and optical fibre thermometers, have been implemented and successfully operated in the furnace for more than 2000 h. The optical fibre thermometers consist of an optical system made of sapphire (two fibres plus a prism in between for deflection) and transmit the infra-red radiation of the heater to the outside of the hot core of the furnace for pyrometric temperature measurement.

A dedicated control algorithm has been set up which controlled the power settings to the individual heaters. Both sensor types showed no degradation after this period and yielded a short-term stability at 1200°C of 0.05°C (optical fibre thermometers), respectively 0.08°C (thermocouples).

## Introduction

For float zone crystal growth experiments onboard the International Space Station (ISS) the implementation of a dedicated heater insert for the Materials Science Laboratory (MSL) is envisaged - the Float Zone Furnace with Magnetic Field (FMF) [1]. One of the essential parameters to control inhomogeneities in the crystal growth of semiconductor materials is the short-term temperature stability (in the range of several minutes) of the furnace [2]. To set up a high-precision temperature control system requires an appropriate combination of fast actuators (heaters) and sensors as well as the implementation of a sophisticated temperature control system. This furnace is especially designed to provide enhanced short-term temperature stability in addition to the ability of adjusting the temperature gradient at the solid-liquid interface over a wide range. The specification on the short-term stability of the furnace was set to  $\Delta T < 0.05^\circ\text{C}$ . In a laboratory model of this furnace the above mentioned features have been addressed in the design and the performance has been verified in an experimental test programme.

In the following sections of this paper the detailed design of the respective subsystems of the FMF furnace to achieve a short-temperature stability - the heating system, the thermometry and the control system - will be introduced, the results of the performance tests reported, and a summary given.

## Heating system

In order to provide a zone profile at  $1500^\circ\text{C}$  with a variable gradient at the solid/liquid interface, the FMF is laid out as a furnace with 7 individually controlled heating zones. In the area of the central zone the melt zone is established. Figure 1 shows a conceptual sketch of the FMF.

The single heaters consist of encapsulated graphite heaters where a meandered graphite layer ( $50\ \mu\text{m}$  thick) is deposited onto a pBN substrate. The heating layer is covered by a second pBN CVD layer to protect it against mechanical, electrical, and chemical injuries. The resulting thickness of wall of less than 2 mm provides a rather low thermal mass enabling fast heating rates and temperature changes. Due to the excellent material compatibility between the different materials and similar values for thermal expansion this type of heater can bear up a power density of more than  $30\ \text{W}/\text{cm}^2$  leading to a compact design for high-temperature applications and also to long operation times of more than 2000 h. Figure 2 shows a photograph of the central heater of the FMF.

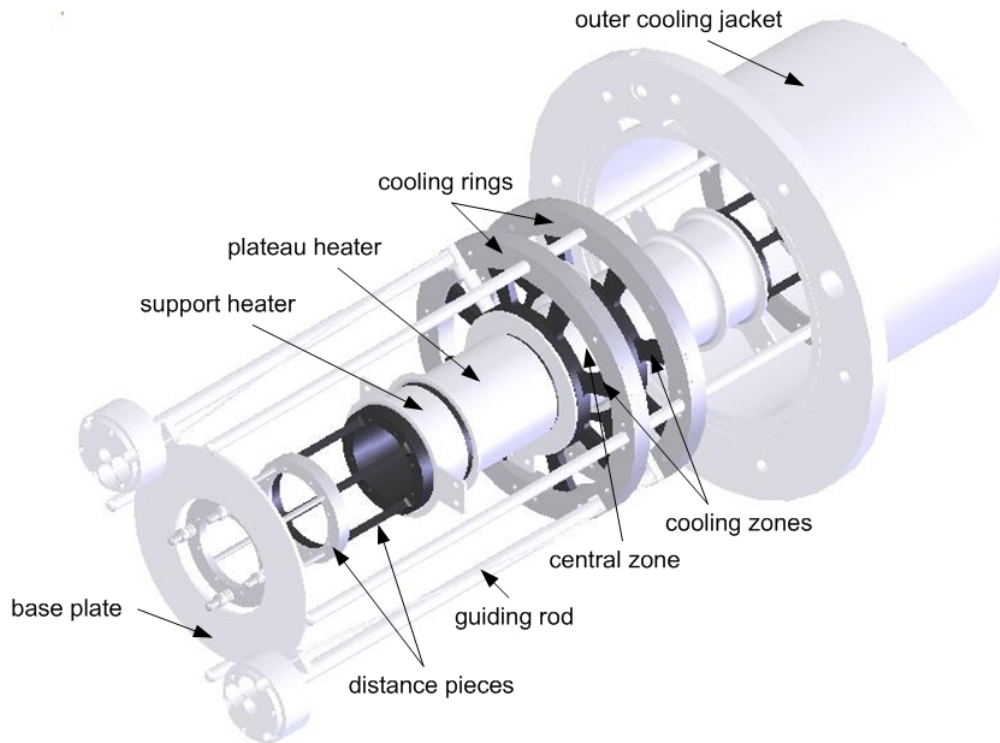

Figure 1. Conceptual sketch of the FMF exhibiting the inner structure of the furnace: The furnace provides a symmetrical thermal profile with seven individual heating zones. Six zones are placed symmetrically at both sides of the central heater (on each side a cooling zone, a support, and a plateau heater is placed).

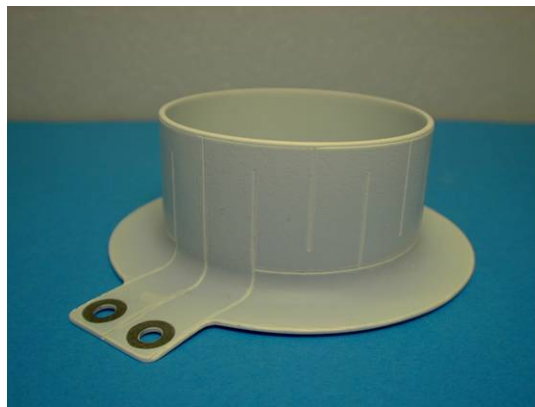

Figure 2. Encapsulated graphite heater for the central zone of the FMF: The thermal load of 1000 W provides a maximum temperature of 1500°C in this area

To improve the radial homogeneity of the temperature profile in the FMF tubular thermal diffusors for each zone consisting of a graphite tube have been employed; thereby the heaters are placed directly around the diffusors tubes.

## Thermometry

For temperature measurement and control each zone is equipped with two thermocouples. Additionally, one optical sensor is employed in the three inner zones of the furnace. The temperature control system of the furnace could thereby use signals of both sensor types as input.

### Thermocouples

The application of sheathed thermocouples represents the standard technique for temperature measurement and control in furnaces. The achieved stability amounts to about 0.1 K [3]. For temperature above 1200°C only type C (W-Re) or type B (Pt-Rh) thermocouples can be applied. Because of the better drift behaviour type B thermocouples with the following specifications have been selected:

- Type B (Pt-PtRh)
- Insulation material: MgO
- Sheath Pt ( $\varnothing$ : 1,0 mm)
- Protection tube Ta ( $\varnothing$ : 1,6 x 0,1 mm)

The thermocouples were implemented into axial borings in the diffusors. In order to prevent a degradation of the Pt sheath due to a reaction with the graphite diffusor they were inserted into protection tubes of Ta. The compatibility of this protection tube with a graphite environment has been tested in advance for several hours at 1600°C in vacuum ( $1 \times 10^{-5}$  mbar). No drifts or degradation have been observed.

### Optical Sensors

According to Planck's law higher temperature resolution can be obtained by utilising optical fibre thermometry with sapphire fibres at elevated temperatures [4, 5]. These sensors consist of an optical waveguide to transmit the IR radiation emitted from a small spot of the object to be measured out of the hot region to a photo detector which converts the radiation signal into a temperature reading following Planck's law. For application in high-temperature facilities these waveguide are made of sapphire. Using straight fibres in a 4-zone laboratory furnace a short-term stability of 0.015°C has been achieved [6].

Due to constructional boundary conditions of the MSL facility the sensors may not be routed in a straight line within the furnace, one 90° bend of the sensors has to be included. For the FMF optical sensors this is realised by the Optical Deflection System (ODS) which is built up by straight sapphire waveguides. The path of rays is being deflected by a sapphire prism which is embedded in a support structure out of ceramic. To enhance transmission by focussing a sapphire lens is implemented behind the prism. Similarly to the thermocouple design the sapphire fibres are integrated into protection tubes out of alumina. The distance to the heater surface amounts to 2 mm. The final transmission for the ODS was measured to amount to 40%. Three out of 7 heating zones of the FMF have been equipped with an ODS as illustrated in Fig. 3.

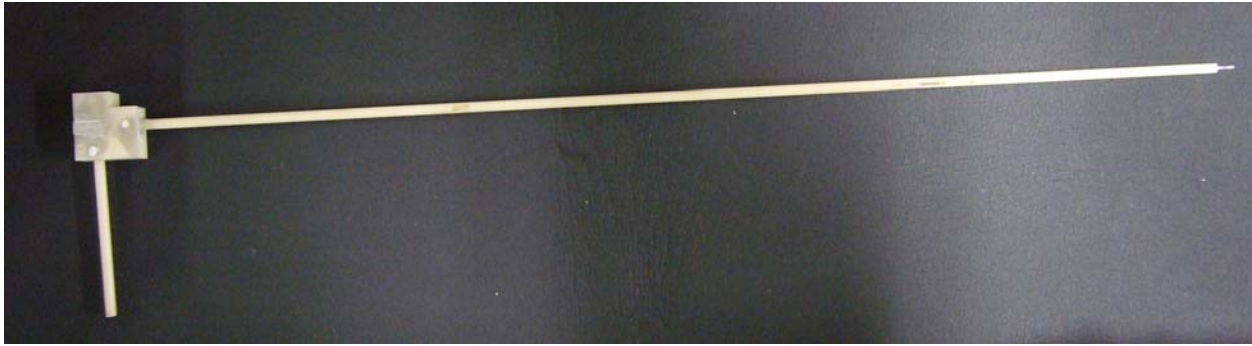

Figure 3. Example of an ODS sensor: The short arm is directed to the hot side, the long arm is routing the IR signal out of the hot core; at its end a conventional quartz fibre leads the signal to a Si photo diode located outside the furnace.

### **Temperature Control Algorithm**

The developed high-precision temperature control system is based on a holistic view of the furnace, reflecting sensors, heaters, software, and control algorithm. Since the individual zones are not adiabatically separated from each other, an initial temperature difference between the zones causes thermal fluxes which affect the temperatures of the zones again. Hence, there exists a strong thermal coupling between zones and the furnace is to be regarded as a multiple-input multiple-output (MIMO) plant. In order to develop an optimised feedback controller the thermal properties of each zone as well as the couplings have to be known exactly. In a first step a theoretical furnace model based on conduction and radiation between the zones is established, and then the unknown parameters are experimentally determined by process identification. This means measuring the dynamic temperature changes as response to well-defined power signals (Pseudo Random Binary Signal). These semi-empirical data represent the input for the parameter estimation algorithm which finds optimised model parameters. The obtained model is basis for feedback controller synthesis [7]. The final controller consists of a separate, standard PID (Proportional-Integral-Differential)-algorithm for each zone with pre-filter, pilot control, decoupling and anti-reset-wind-up. This structure and the V-canonical plant are depicted in Fig. 4. A V-canonical structure means that the loop interactions are regarded as feedback couplings, hence modifying the input signal.

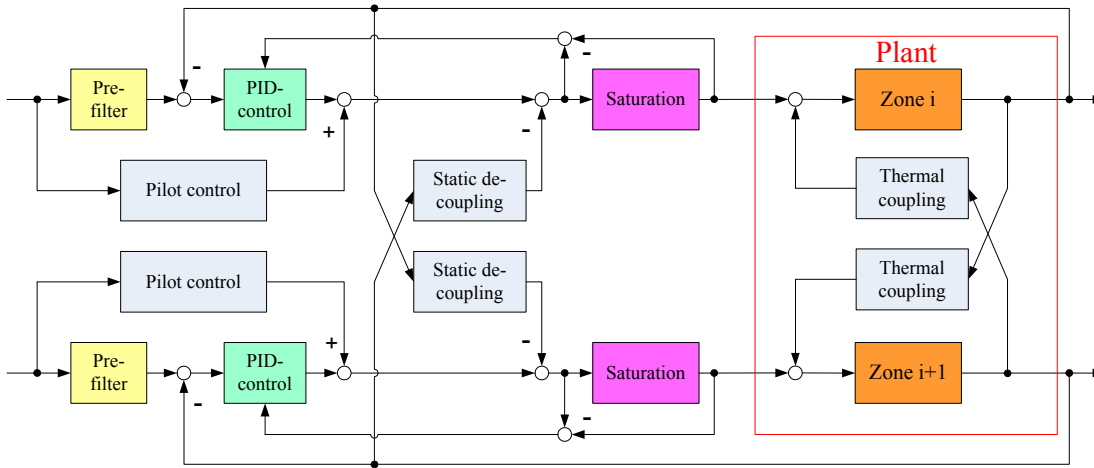

Figure 4. Structure of the feedback controller and the V-canonical MIMO plant as example for two zones: Thereby the power setting to zone I depend on the temperature of this zone and of its neighbouring zones via the thermal coupling which have to be experimentally determined.

### Tests

At 1200°C the short-term stability has been investigated for both type of sensors control (thermocouples or ODS). The central heaters were set to 1200°C and the cooling zone to 1100°C to establish a temperature gradient of 50 K/cm. The test was performed over a time period of 18 h (ODS) and 20 h (TC). In the central zone temperature fluctuations of  $\Delta T = 0.05^\circ\text{C}$  could be achieved for control with the ODS sensors, and  $\Delta T = 0.051^\circ\text{C}$  for control with thermocouples as shown in Fig. 5. In the cooling zones even better values of  $\Delta T = 0.026^\circ\text{C}$  (ODS) and  $\Delta T = 0.05^\circ\text{C}$  (TC) could be obtained.

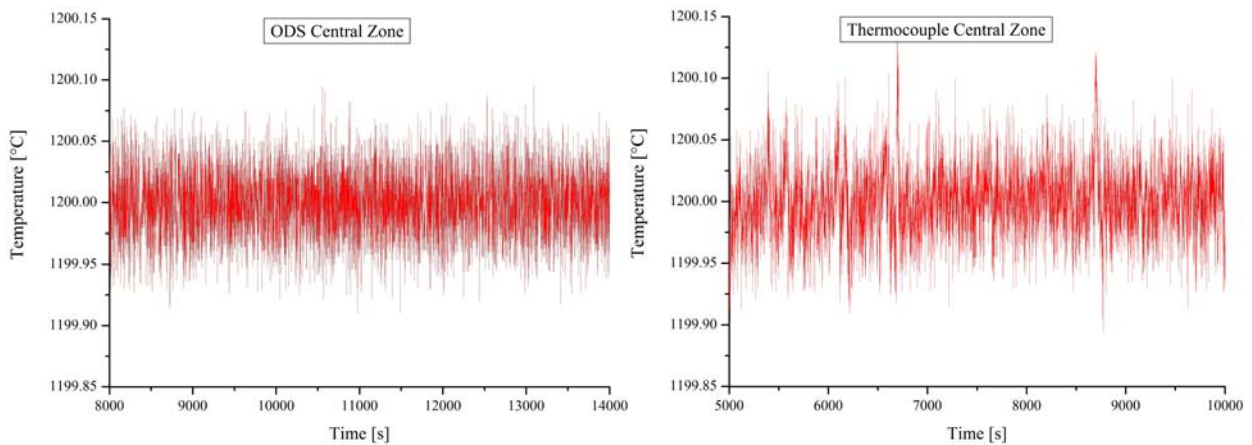

Figure 5: Measured short-term temperature stability for control with ODS sensors (left) and with thermocouples (right)

## Conclusion

Temperature control within a multi-zone furnace for semiconductor crystal growth has been realised with thermocouples and optical sensors as input signals for the control algorithm. With both systems a superior short-term stability of less than  $\Delta T < 0.05^\circ\text{C}$  could be achieved in a multi-zone high-temperature furnace. No significant performance difference between the two types of sensors could be detected in the investigated temperature range. However, for environments with strong EMC perturbations the optical sensors reveal some advantage.

## References

- [1] Hess, A., Cröll, A., Stenzel, C., Bräuer, D., Sauermann, H., Uhlig, V., *Floating Zone Furnace with Rotating Magnetic Field*. Poster Presentation DGKK 2010
- [2] Müller, G., *Convection and Inhomogeneities in Crystal Growth from the Melt*, in: *Crystal Growth, Properties and Applications*, Vol. 3, III-V Semiconductors, Springer-Verlag, Berlin, Heidelberg, New York, 1980
- [3] Sauermann, H., Schneider, K., Janda, O., Gröll, L., Bretthauer, G., Linn, H., *Das Gradient-Freeze Verfahren und seine regelungstechnische Umsetzung*. 39. IWK der TU Ilmenau, 1994, p. 809-817
- [4] Schietinger, C.: *Temperature measurements using optical fibers*, in: *Thermal Measurements in Electronics Coolings*, ed. K. Azar CRC Press, 1997, Boca Raton
- [5] Dils, R. R., *J. Appl. Phys.*, **54**, 1983, p. 1198
- [6] H. Sauermann, Ch. Stenzel, S. Keesmann, B. Bonduelle, *Cryst. Res. Technol.* **36**, 2001, p. 1329-1343
- [7] Hermann, K., Rehkopf, A., Sauermann, H., *Betrachtungen zur Identifikation einer Gradient-Freeze-Anlage zur Einkristallzüchtung*, *Automatisierungstechnik*, Vol. 54 2006, p. 566-573