

NASA/TM-2013-218004



Acoustic Performance of a Real-Time Three-Dimensional Sound-Reproduction System

Kenneth J. Faller II
California State University, Fullerton, California

Stephen A. Rizzi
Langley Research Center, Hampton, Virginia

Aric R. Aumann
Analytical Services and Materials, Inc., Hampton, Virginia

June 2013

NASA STI Program . . . in Profile

Since its founding, NASA has been dedicated to the advancement of aeronautics and space science. The NASA scientific and technical information (STI) program plays a key part in helping NASA maintain this important role.

The NASA STI program operates under the auspices of the Agency Chief Information Officer. It collects, organizes, provides for archiving, and disseminates NASA's STI. The NASA STI program provides access to the NASA Aeronautics and Space Database and its public interface, the NASA Technical Report Server, thus providing one of the largest collections of aeronautical and space science STI in the world. Results are published in both non-NASA channels and by NASA in the NASA STI Report Series, which includes the following report types:

- **TECHNICAL PUBLICATION.** Reports of completed research or a major significant phase of research that present the results of NASA Programs and include extensive data or theoretical analysis. Includes compilations of significant scientific and technical data and information deemed to be of continuing reference value. NASA counterpart of peer-reviewed formal professional papers, but having less stringent limitations on manuscript length and extent of graphic presentations.
- **TECHNICAL MEMORANDUM.** Scientific and technical findings that are preliminary or of specialized interest, e.g., quick release reports, working papers, and bibliographies that contain minimal annotation. Does not contain extensive analysis.
- **CONTRACTOR REPORT.** Scientific and technical findings by NASA-sponsored contractors and grantees.

- **CONFERENCE PUBLICATION.** Collected papers from scientific and technical conferences, symposia, seminars, or other meetings sponsored or co-sponsored by NASA.
- **SPECIAL PUBLICATION.** Scientific, technical, or historical information from NASA programs, projects, and missions, often concerned with subjects having substantial public interest.
- **TECHNICAL TRANSLATION.** English-language translations of foreign scientific and technical material pertinent to NASA's mission.

Specialized services also include organizing and publishing research results, distributing specialized research announcements and feeds, providing information desk and personal search support, and enabling data exchange services.

For more information about the NASA STI program, see the following:

- Access the NASA STI program home page at <http://www.sti.nasa.gov>
- E-mail your question to help@sti.nasa.gov
- Fax your question to the NASA STI Information Desk at 443-757-5803
- Phone the NASA STI Information Desk at 443-757-5802
- Write to:
STI Information Desk
NASA Center for AeroSpace Information
7115 Standard Drive
Hanover, MD 21076-1320

NASA/TM-2013-218004



Acoustic Performance of a Real-Time Three-Dimensional Sound-Reproduction System

Kenneth J. Faller II
California State University, Fullerton, California

Stephen A. Rizzi
Langley Research Center, Hampton, Virginia

Aric R. Aumann
Analytical Services and Materials, Inc., Hampton, Virginia

National Aeronautics and
Space Administration

Langley Research Center
Hampton, Virginia 23681-2199

June 2013

Acknowledgments

The authors wish to acknowledge Noah Schiller, Randolph H. Cabell and Jacob Klos of the NASA Langley Research Center for their assistance with the equalization filter development, and William L. Chapin of AuSIM, Inc. for the Vectsonic system development support.

This research was supported by an appointment to the NASA Postdoctoral Program at the NASA Langley Research Center, administered by Oak Ridge Associated Universities (ORAU) through a contract with NASA. Funding was provided by the Subsonic Rotary Wing project of the NASA Fundamental Aeronautics Program.

Trade names and trademarks are used in this report for identification only. Their usage does not constitute an official endorsement, either expressed or implied, by the National Aeronautics and Space Administration.

Available from:

NASA Center for AeroSpace Information
7115 Standard Drive
Hanover, MD 21076-1320
443-757-5802

Abstract

The Exterior Effects Room (EER) is a 39-seat auditorium at the NASA Langley Research Center and was built to support psychoacoustic studies of aircraft community noise. The EER has a real-time simulation environment which includes a three-dimensional sound-reproduction system. This system requires real-time application of equalization filters to compensate for spectral coloration of the sound reproduction due to installation and room effects. This paper describes the efforts taken to develop the equalization filters for use in the real-time sound-reproduction system and the subsequent analysis of the system's acoustic performance. The acoustic performance of the compensated and uncompensated sound-reproduction system is assessed for its crossover performance, its performance under stationary and dynamic conditions, the maximum spatialized sound pressure level it can produce from a single virtual source, and for the spatial uniformity of a generated sound field. Additionally, application examples are given to illustrate the compensated sound-reproduction system performance using recorded aircraft flyovers.

Contents

1	Introduction	3
2	VBAP Implementation in the EER	6
3	Equalization Filters	8
3.1	Ideal Equalization Filters	9
3.2	Wiener Equalization Filters	9
3.3	IIR Equalization Filters	10
4	Time-Delay and Gain Compensation	12
4.1	Time-Delay Compensation	12
4.2	Relative Gain Compensation	13
5	Acoustic Performance	14
5.1	Crossover Performance	14
5.2	Stationary Performance	15
5.3	Dynamic Performance	16
5.4	Maximum Spatialized SPL	17
5.5	Spatial Uniformity	18
6	Application Examples	19
7	Concluding Remarks	20
8	Appendix - Installed Speaker Locations	21
9	References	22

1 Introduction

The primary function of the Exterior Effects Room (EER) is to conduct psychoacoustic studies of aircraft community noise [1–6]. A secondary function of the EER is as a general meeting space (e.g., presentations). The EER sound-reproduction system was originally only capable of reproducing monaural playback of pre-recorded aircraft flyovers. In order to achieve a more realistic simulation environment using both synthetic and recorded flyovers, a real-time three-dimensional (3D) sound-reproduction system was recently installed. The new 31-channel sound-reproduction system consists of twenty-seven full-range Klein & Hummel (K&H) O300 satellite loudspeakers and four K&H O900 subwoofer loudspeakers. The loudspeakers provide a combined uncompensated frequency range from 16 Hz to 20 kHz. The subwoofers are embedded in the walls at the corners of the room and the satellites are positioned in the half and corner spaces of the room. The satellite loudspeakers located in the lower half of the room are baffled to protect the audio equipment and personnel, see Figure 1. Speaker designations are also indicated in Figure 1. Three speakers (0.5, 1.5, and 2.5) are located on the room left/right center line, with speakers 0.5 and 1.5 at the front of the room and speaker 2.5 in the rear. The remaining speakers are located in nominally symmetric locations. Speakers 4L/R, 5L/R, and 6L/R are located in the ceiling. Subwoofers 15L/R and 16L/R are embedded in the front and rear walls, respectively.

The room dimensions are shown in the floor plan in Figure 2. Installed speaker locations relative to the center microphone location, at the x-y origin in Figure 2, are provided in the appendix. The center microphone location was at a height of 52-in (1.32m) above the lowest floor level at the front of the room.

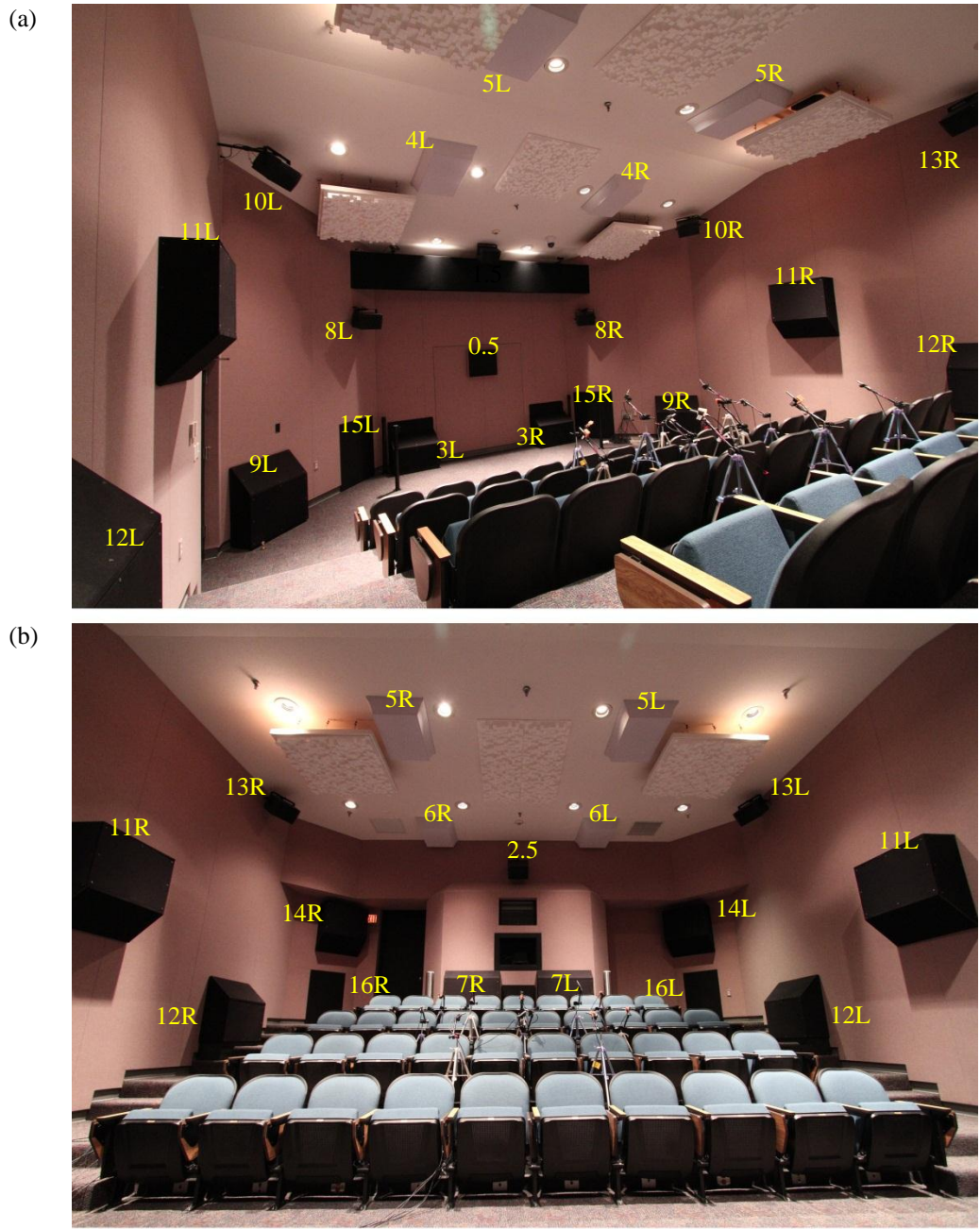

Figure 1: Front (a) and rear (b) views of the EER showing the mounted satellite and subwoofer speaker locations.

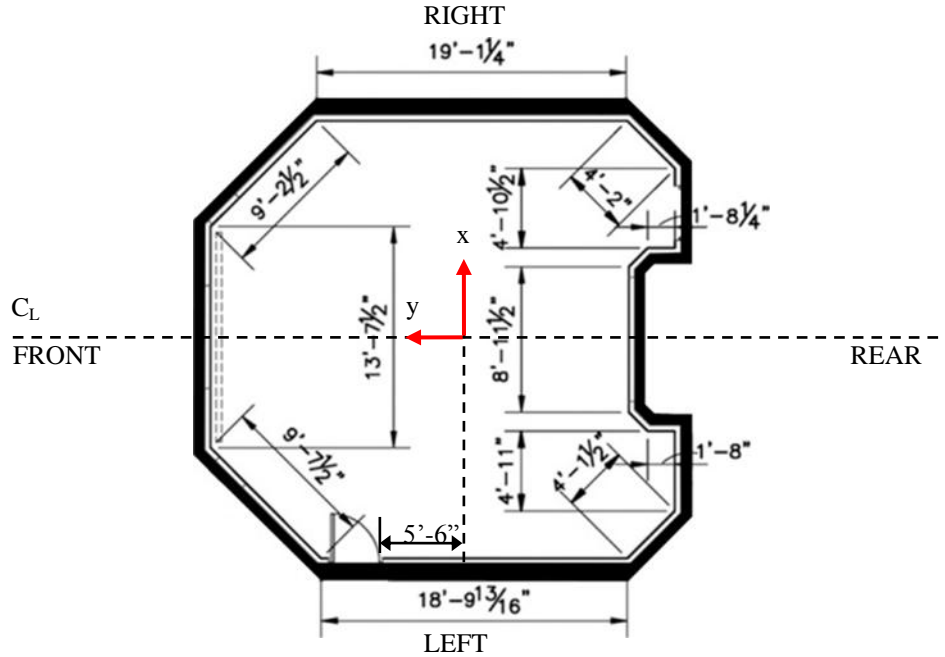

Figure 2: Floor plan of the EER outline (dimensions in feet - inches).

The sound-reproduction system also includes a real-time Digital Signal Processing (DSP) engine which can produce 3D spatial audio in the EER using an implementation of Vector-Base Amplitude Panning (VBAP) [7, 8]. VBAP is an extension of the familiar 2D stereo panning technique, which uses a pair of loudspeakers to pan a virtual source (Figure 3a). With VBAP, the virtual source can be panned in three dimensions. For VBAP, a triangular panning area is formed by a loudspeaker triplet and a virtual source is panned within this area by manipulating the gains of the loudspeakers (Figure 3b). If more than three loudspeakers are available, then a set of non-overlapping triangles are formed between the loudspeakers and a virtual source can be panned within this triangle set (see Figure 3c). The VBAP implementation used in the EER is discussed in Section 2.

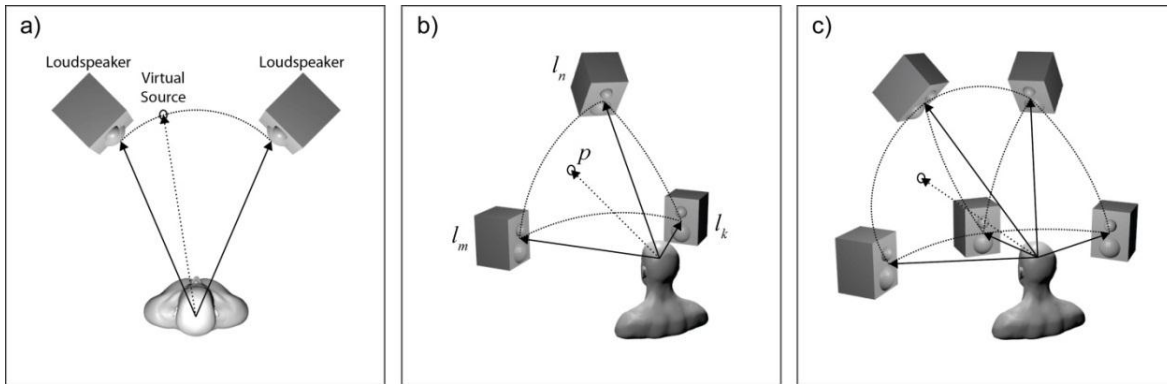

Figure 3: Stereo and VBAP loudspeaker arrangements for, a) a stereo pair, b) a single triplet and, c) multiple triplets (3D head, shoulder, and chest model by [9]).

The arrangement of the loudspeakers in the EER is non-spherical and the EER itself is non-anechoic. Hence, loudspeaker-specific equalization is necessary to compensate for the spectral colorization, time delay, and gain resulting from these non-ideal acoustic conditions. In addition, crossover filters are needed to split the audio signal(s) into lower and higher frequency bands which are subsequently routed to the respective subwoofer and satellite loudspeakers. The DSP required of the real-time system thus

involves both dynamic VBAP gain application for moving virtual sources, and fixed filter, time delay and gain processing for equalization, as depicted in Figure 4. The DSP for VBAP is performed using the AuSIM3D[®] Vectsonic[™] option for the AuSIM3D[®] Engine [10], which also performs the remaining DSP for equalization.

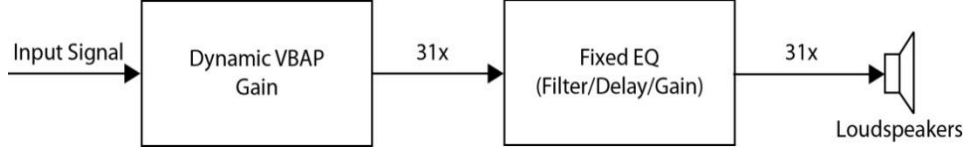

Figure 4: Real-time digital signal processing path for the EER sound-reproduction system. Dynamic gain and fixed equalization are performed for all 31 channels at all times.

The remainder of the paper describes the VBAP implementation used in the EER, the design and implementation of fixed equalization for the EER sound-reproduction system, including equalization (color compensation and crossover) filters, full-path time delay compensation, and relative gain compensation between loudspeakers. The acoustic performance is then demonstrated under various uncompensated and compensated conditions.

2 VBAP Implementation in the EER

The gain factors used to position a virtual source p within a speaker triangle set (l_n, l_m, l_k) are determined by the geometrical relationship of the listener to the speaker set and virtual source [7, 8], see Figure 3b. Given the loudspeaker direction vectors,

$$\begin{aligned} l_n &= [l_{n1} \ l_{n2} \ l_{n3}]^T \\ l_m &= [l_{m1} \ l_{m2} \ l_{m3}]^T \\ l_k &= [l_{k1} \ l_{k2} \ l_{k3}]^T \\ \mathbf{L}_{nmk} &= [l_n \ l_m \ l_k]^T \end{aligned} \quad (1)$$

and the panning direction vector

$$\mathbf{p} = [p_n \ p_m \ p_k]^T = g_n l_n + g_m l_m + g_k l_k \quad (2)$$

the gain factors are obtained as

$$\mathbf{g} = [g_n \ g_m \ g_k]^T = \mathbf{p}^T \mathbf{L}_{nmk}^{-1} \quad (3)$$

For the EER system, the gain factors are pre-computed for a large but finite number of virtual sources at regularly spaced grid points within the triangle and intermediate locations are estimated during runtime using interpolation. Two separate VBAP triangle sets are used in the EER: one for the satellite loudspeakers and one for the subwoofer loudspeakers. Both sets are shown in Figure 5.

During the installation of the 3D sound reproduction system, it was decided to utilize existing penetrations in the ceiling for mounting loudspeakers 4 L/R, 5L/R and 6 L/R. As a consequence, the triangle sets defined by these loudspeakers were not unique. Specifically, for the quadrilateral defined by loudspeakers 4 L/R and 5 L/R, triangle sets 4L-4R-5R and 4L-5L-5R are equally as valid as triangle sets 4L-4R-5L and 4R-5L-5R (see Figure 5a). Similarly, for the quadrilateral defined by loudspeakers 5L/R and 6 L/R, triangle sets 5L-5R-6R and 5L-6L-6R are equally as valid as triangle sets 5L-5R-6L and 5R-6L-6R. Selection of one triangle set over the other leads to sudden and perceivable level changes in the sound reproduction as a virtual source was panned across these sets [11]. To resolve this issue, virtual loudspeakers were positioned between loudspeakers 4 L/R and 5 L/R, and between loudspeakers 5 L/R and 6 L/R, as shown in Figure 5a. A virtual loudspeaker is a means of specifying a loudspeaker direction vector for a point at which there is no physical loudspeaker, see equation (1). The gain attributed to the

virtual loudspeaker is then apportioned equally amongst the neighboring physical loudspeakers. For example, a virtual source located in the triangle defined by loudspeakers 4 L/R and the virtual loudspeaker between loudspeakers 4L/R and 5 L/R would produce the following physical loudspeaker gains:

$$\begin{aligned}
 g_{4L} &= g_{4L}^V + \frac{1}{4} g_{Virtual}^V \\
 g_{4R} &= g_{4R}^V + \frac{1}{4} g_{Virtual}^V \\
 g_{5L} &= 0 + \frac{1}{4} g_{Virtual}^V \\
 g_{5R} &= 0 + \frac{1}{4} g_{Virtual}^V
 \end{aligned} \tag{4}$$

where the superscript V denotes the VBAP gain obtained for the triangle defined by loudspeakers 4 L/R and the virtual loudspeaker. The use of virtual loudspeakers on the ceiling was found to eliminate the perceived level changes for virtual sources panned between loudspeakers 4 L/R, 5 L/R, and 6 L/R.

A virtual loudspeaker was also used to conditionally replace a physical loudspeaker. The EER contains a 3D visual system that requires a projection screen which, when lowered, obstructs loudspeaker 0.5 directly in front of the EER. Equalization could not adequately overcome the resulting coloration, causing an audible high frequency attenuation as a source was panned through the corresponding triangles. Improved sound reproduction was achieved by replacing loudspeaker 0.5 with a virtual loudspeaker consisting of loudspeakers 1.5-3L-3R-8L-8R, as shown in Figure 5b/c. The appropriate triangle set, i.e. with or without the virtual loudspeaker, is loaded at runtime depending on the position of the screen.

A third application of virtual loudspeakers was implemented for the subwoofers. As will be discussed in section 3.2, the subwoofers were low-pass filtered so that their output would not be localized. The 3D localization achieved with the EER sound reproduction system is thus attributable to the satellite loudspeakers alone. The option of simply sending $\frac{1}{4}$ of the full low-pass filtered signal to each of the four subwoofers was not possible due to the DSP system architecture. All loudspeakers, satellites and subwoofers, were processed using the same DSP, inclusive of VBAP. Since the subwoofers lie on the plane defined by 15L-15R-16L-16R, it is necessary to place virtual speakers above and below that plane for the VBAP algorithm to reproduce any sound off-plane, which is most commonly the case. The triangle sets shown in Figure 5d are used for this purpose. In this manner, all four subwoofers are active, albeit with different gains, at all times.

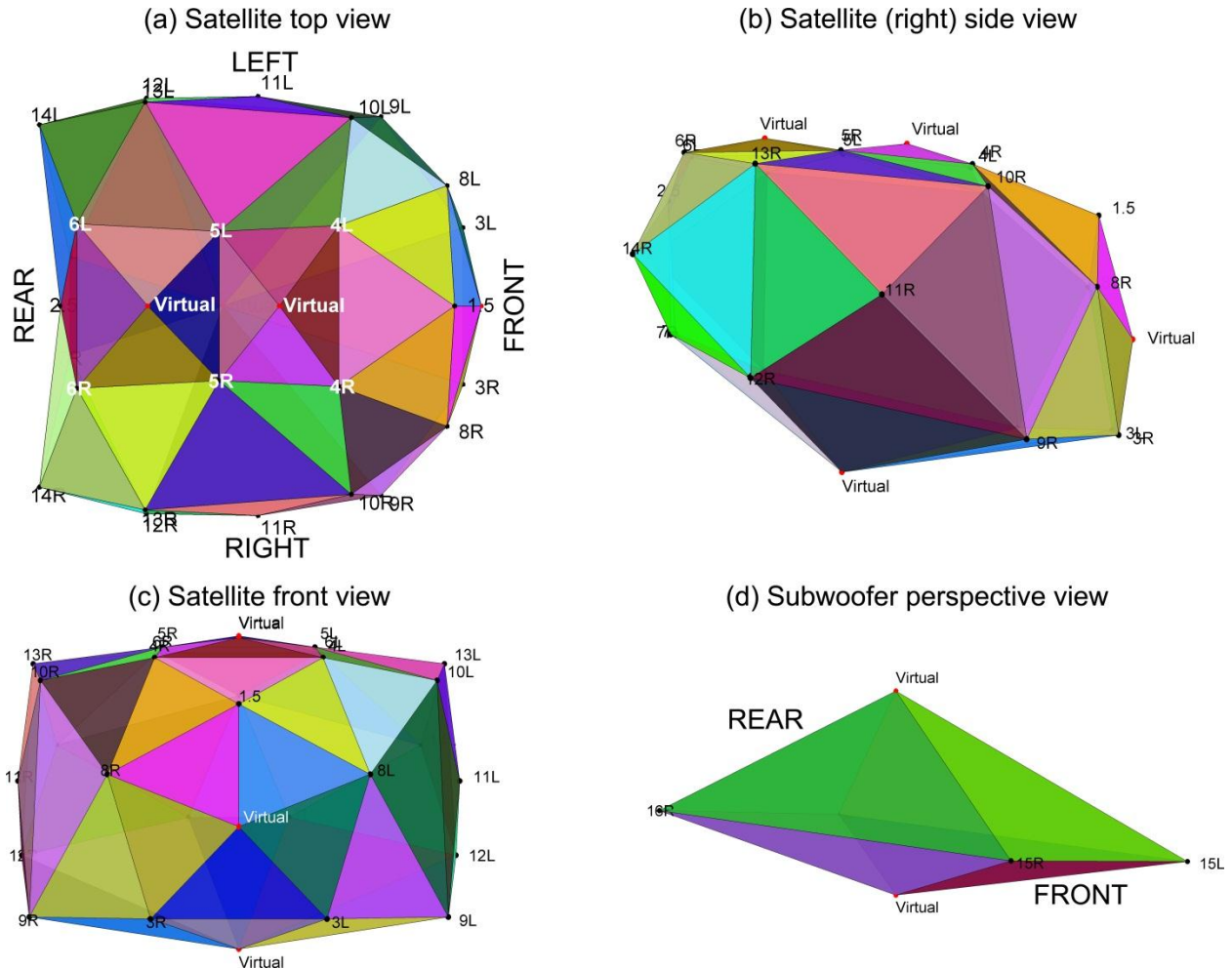

Figure 5: VBAP triangle sets for the satellite (a-c) and subwoofer (d) speakers in the EER.

3 Equalization Filters

Each channel of the EER sound reproduction system, being unique in its installation, must be individually equalized. The basic concept behind this equalization is shown in block diagram form in Figure 6. The digital equalization filter ($H(z)$) is used to compensate the input signal ($x(n)$) such that the error ($e(n)$) between the microphone response(s) ($\hat{d}(n)$) and the desired response ($d(n)$) is either eliminated or minimized.

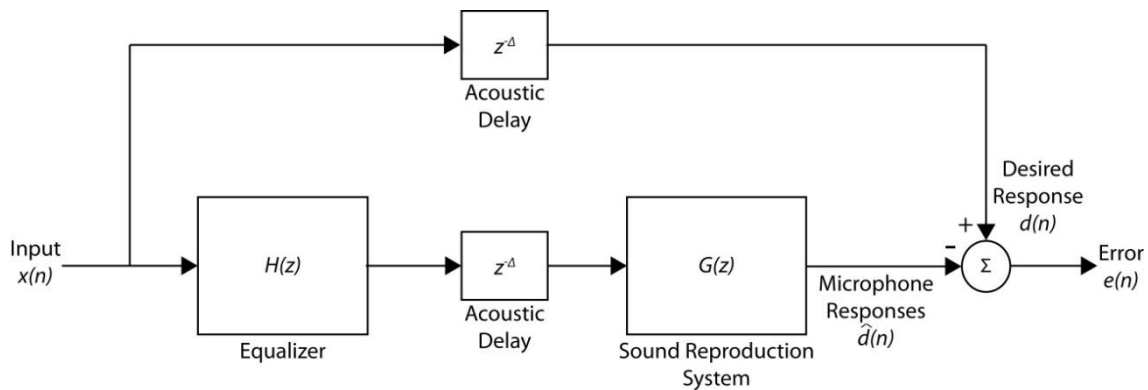

Figure 6: Equalization problem of the sound reproduction system.

The microphone response(s) ($\hat{d}(n)$) can be measured at a single microphone location or at multiple microphone locations. When equalizing at a single microphone location, it has been shown that degradation of the response can occur at other positions. Improvement can be achieved by using the sum of square of the modeling error ($e(n)$) at multiple microphone locations [12] as the cost function. Two microphone configurations were considered in this effort; a set of twelve microphones randomly positioned within the seating area of the EER, or a two microphone subset located in the center of the room. The microphone arrangement is visible in Figure 1.

3.1 Ideal Equalization Filters

Ideal equalizers can be obtained from the exact inverse of the frequency responses of the digital filter representation of the sound-reproduction system response ($G(z)$). Theoretically, zero error can be achieved with an ideal equalizer and model of the delay (z^{-d}) introduced in the acoustic path. However, it is known that ideal equalizers only work in offline simulations. Even for a simple point-to-point reproduction path, response measurement accuracy limitations and minor non-stationarity of the path make ideal equalization impossible [13]. In fact these ideal EQs were found to produce audible artifacts, specifically a “ringing” artifact, when employed in the EER.

3.2 Wiener Equalization Filters

Elliot and Nelson [14] posed the equalization problem as one of linear optimum filtering or Wiener filtering. This approach minimizes the error between the microphone(s) and desired response instead of attempting to set the error to zero. It assumes the Wiener equalization filter and the sound-reproduction system can be represented by digital Linear Time Invariant (LTI) filters which allows for the specification of the filter by its impulse response. The resulting Wiener finite impulse response (FIR) filter avoids sensitivity to frequency bin spacing which occurs with a frequency domain approach. One drawback to this approach is that it requires solution of a Toeplitz system of linear equations. Standard methods for solving this type of problem, such as Gauss-Jordan elimination, usually requires $O(N^3)$ operations [15]. This can result in lengthy calculation times and, for large matrices, may require considerable memory resources. However, the LTI assumption implies that the sound-reproduction system is time invariant and, therefore, equalization filters are precomputed once and then used in the real-time system. Furthermore, the complexity of solving a Toeplitz system of linear equations can be reduced significantly to a general requirement of $O(N^2)$ operations using Levinson-Durbin recursion [15].

Figure 7 illustrates the approach used to solve the equalization problem with a Wiener FIR equalization filter [12]. This solution is similar to the general equalization approach from Section 3.1 except that the ideal equalizer ($H(z)$) is replaced with a Wiener FIR equalization filter ($H_w(z)$) and a desired filter ($K(z)$) is introduced. The desired filter is a digital filter used to specify the desired frequency response of the equalization filter. In this manner, crossover filters can be incorporated into the equalization filters. It is suggested to specify the desired filter as an 8th-order Linkwitz-Riley (L-R) crossover filter because interactions at the crossover points are minimal [16]. The corner frequencies of the desired filter for the subwoofers were set to 17 Hz and 80 Hz. These corner frequencies were selected because 17 Hz is the lower limit of the 20 Hz 1/3-octave band and 80 Hz minimizes the localization contribution from the subwoofers [17]. The corner frequencies for the satellite loudspeakers were set to 80 Hz and 17.23 kHz (44.1 kHz sampling rate/2.56) which is the remainder of the pass-band of interest. The upper corner frequency covers most, but not all, of the 16 kHz 1/3-octave band.

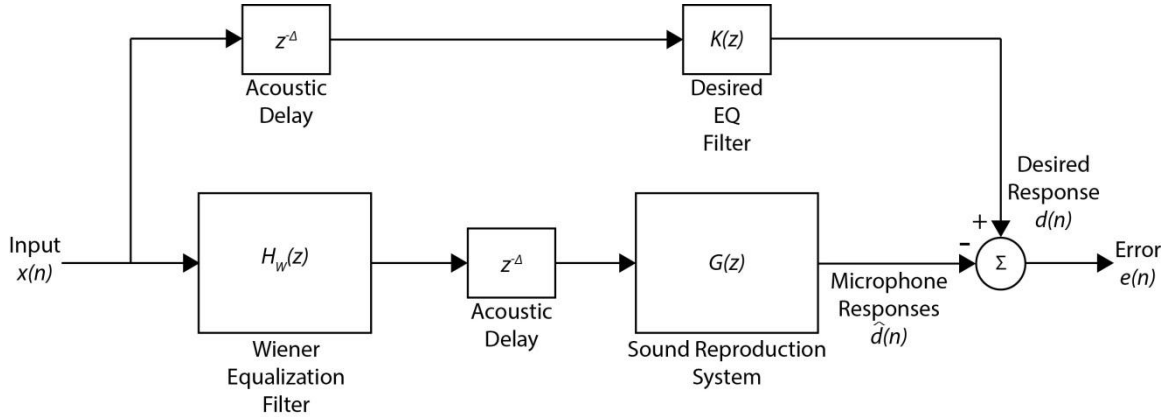

Figure 7: Equalization of the sound reproduction system using a Wiener FIR equalization filter.

In previous work [18], Wiener FIR equalization filters were generated and evaluated in the EER. It was shown that good spectral compensation was achieved within the pass-bands and that no audible artifacts were produced. Additionally, measurements of the full-path time delay (as described in Section 4.1) revealed that delay compensation was achieved to within 0.1 ms across all channels of the EER sound-reproduction system. However, the resulting Wiener FIR equalization filters required 32k and 8k taps for the subwoofer and satellite loudspeakers, respectively. The long filter lengths prevented their use in the real-time sound reproduction system, which requires all output channels to be processed simultaneously (see Figure 4). In order to obtain equalization filters that can be used in a real-time system, the resulting Wiener FIR equalization filters were approximated by reduced-order IIR filters, as next discussed.

3.3 IIR Equalization Filters

Reduced order IIR surrogates of the Wiener FIR equalization filters, amenable to real-time implementation, were generated using the damped Gauss-Newton method for iterative search [19]. Given a complex frequency response, this method estimates a stable IIR filter of specified order that approximates the associated Wiener FIR equalization filter. Here, the order refers to the numerator and denominator polynomials of the Z-domain transfer function representation of the IIR filter. The complex frequency response used to estimate the IIR filter was formed from the magnitude response of the target Wiener FIR equalization filter and a minimum-phase response. The minimum-phase representation was used in lieu of the phase response of the target Wiener FIR equalization filter because it was convenient to sum the time delays associated with the filter and the acoustic path, and to process that with a single delay line in the AuSIM3D[®] DSP engine. The minimum-phase response was estimated using the complex-cepstrum algorithm [20]. A reconstructed minimum-phase filter is achieved by appropriately windowing its cepstrum.

While it may be obvious, the reduced-order IIR filters should have the same pass-bands for the subwoofers and satellites as the Wiener FIR equalization filters upon which they are based. However, initial testing indicated that the IIR filter frequency response of the satellite loudspeakers near the 80 Hz crossover point was not adequately compensated when those filters were based upon the full bandwidth of the Wiener FIR equalization filter (80 Hz – 17.23 kHz). Improved agreement between the desired frequency response and the IIR response was achieved by splitting the single IIR into two IIR equalization filters for each satellite loudspeaker response. These equalization filters had pass-bands of 80 Hz - 500 Hz, and 500 Hz – 17.23 kHz, as shown in Figure 8. The DSP system used is not currently programmed to permit specification of multiple filters for a single loudspeaker. Therefore, the resulting IIR equalization filter pairs for each satellite loudspeaker were summed together into a single IIR

equalization filter. To minimize round-off error, these filters were realized as a cascade of Second-Order Sections (SOSs) or “bi-quads” [21].

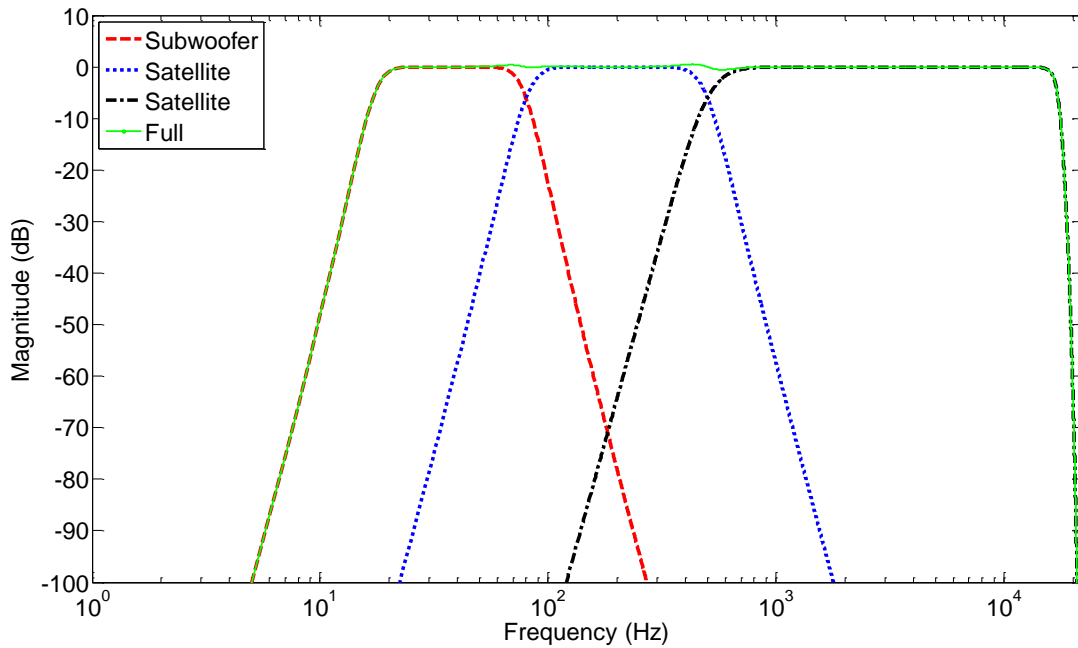

Figure 8: Crossover filter for subwoofers (dashed line), satellite speakers (dotted and dash-dot lines), and the desired response across the full frequency range (solid line).

Undesirable audible behavior (e.g., high frequency ringing) was occasionally observed when implementing the IIR equalization filters with the Intel Integrated Performance Primitives (IPP[®]) DSP libraries [22] employed by the real-time AuSIM3D[®] Engine. To identify any DSP processing issues, the IIR equalization filters were first evaluated offline with the same Intel IPP[®] DSP library functions used in the real-time engine. Accordingly, adjustments were made to the filter parameters (e.g., filter order) until the filtered signal was free of audible artifacts.

Figure 9 show the magnitude responses of a Wiener FIR equalization filter (solid) and the corresponding IIR surrogate equalization filter (dashed) for satellite loudspeaker 1.5 (top) and subwoofer loudspeaker 15L (bottom). The FIR filters shown were obtained using the responses from two centrally located microphones. As can be seen, the pass-bands for both the FIR and IIR equalization filters match closely. The magnitude responses for the other loudspeakers compare equally well.

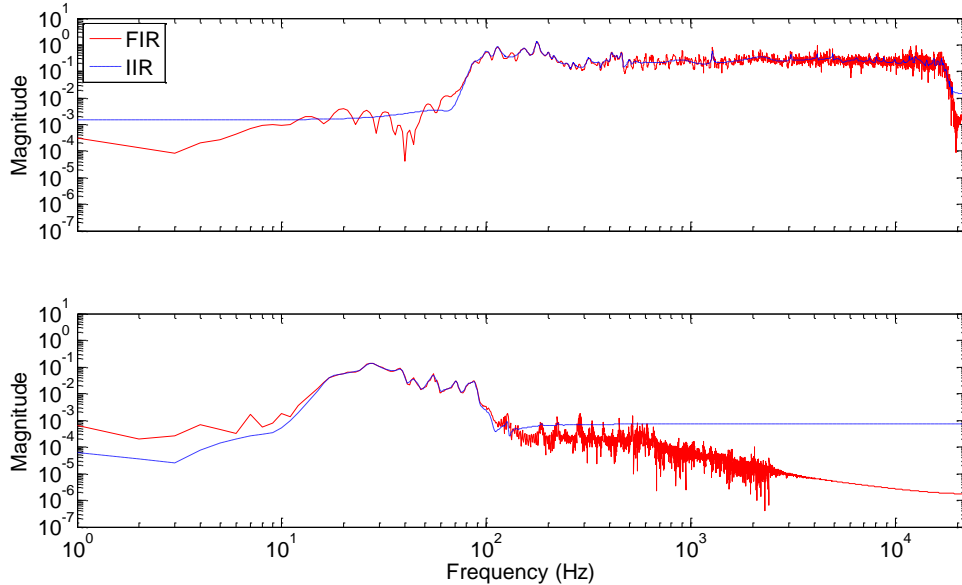

Figure 9: Magnitude response of the Wiener FIR equalization filter (solid) and the IIR equalization filter (dashed) for satellite loudspeaker 1.5 (top) and subwoofer loudspeaker 15L (bottom).

Replacement of the Wiener FIR equalization filters with surrogate IIR equalization filters, reduced the filter order to about 25 SOSs for the subwoofers and 50 SOSs for the satellite loudspeakers. In this form, all 31 IIR equalization filters could be processed simultaneously on the DSP engine.

4 Time-Delay and Gain Compensation

The two remaining parts of the fixed equalization are time-delay and gain compensation. Like the filters, these are determined for each individual loudspeaker.

4.1 Time-Delay Compensation

The delays used for time delay compensation were estimated from the uncompensated loudspeaker impulse responses measured at the central microphone location using a peak detection algorithm [23]. Figure 10 shows the detected peaks (dots) using the peak detection algorithm for the uncompensated and compensated impulse responses for a satellite loudspeaker (solid) and a subwoofer loudspeaker (dashed). As can be seen, the peak detection algorithm accurately determines the first peak in the impulse responses. As shown in the bottom plot of Figure 10, the delays can be used to apply time-delay compensation such that the onsets of the impulse responses align more closely. Figure 11 shows the uncompensated (top) and compensated (bottom) time delays for the satellite (0.5 to 14R) and subwoofer (15L to 16R) loudspeakers. The longest time delay of 15.69 ms is associated with the farthest loudspeaker (subwoofer 15R), while the shortest delay of 8.8 ms is associated with the closest loudspeaker (satellite 7R). These are consistent with the installed ranges indicated in the appendix. As can be seen, there is a maximum difference of about 6.89 ms, or about 2.4 m at standard sea level conditions, between the smallest and largest time delays before time-delay compensation. After compensation, the delay difference is reduced to 0.091 ms or about 3 cm.

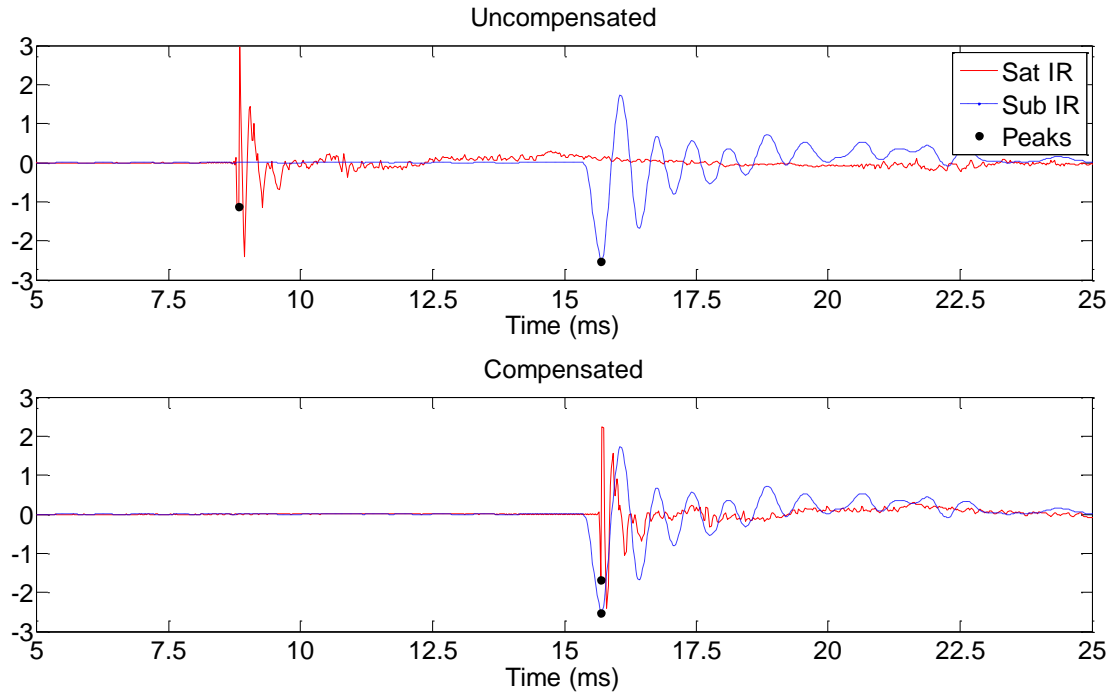

Figure 10: Uncompensated and compensated impulse responses for a satellite loudspeaker (solid), a subwoofer loudspeaker (dashed), and the corresponding detected peaks (dots).

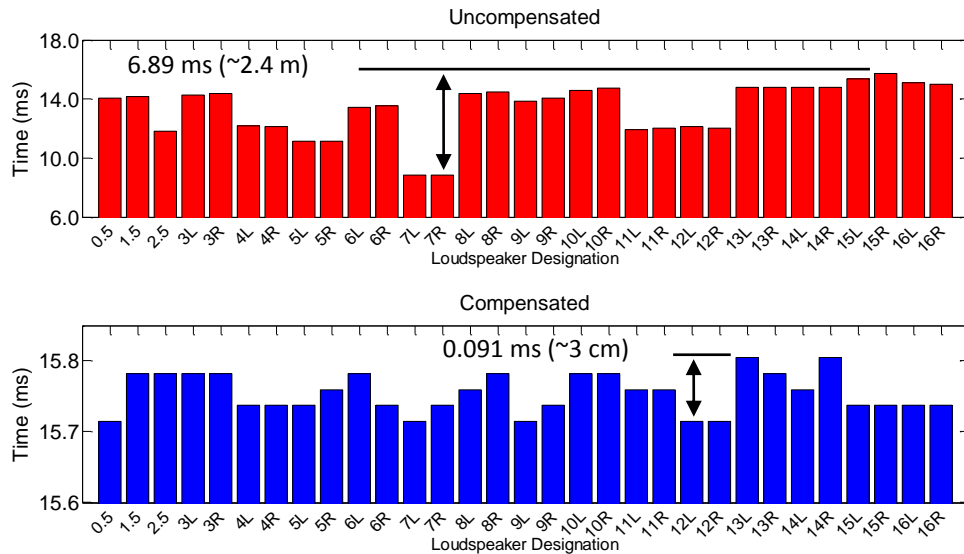

Figure 11: Uncompensated and compensated time delay for the satellite (0.5 to 14R) and subwoofer (15L to 16R) loudspeakers.

4.2 Relative Gain Compensation

The mean sound pressure level (SPL) for each loudspeaker, as measured at the two co-located center microphones, varied due to differences in range and installation effects. The mean level was estimated by calculating the average of the 1/3-octave band levels within the pass-band of the cross-over filter, i.e. after equalization filter compensation. Sufficient headroom in the signal path allowed for an increase in the individual loudspeaker gains such that the mean level of each loudspeaker was set to match the highest mean level. Figure 12 shows the mean levels for the loudspeakers before (top) and after (bottom) gain compensation. The difference between the minimum and maximum uncompensated mean levels for the

satellites (0.5 to 14R) was about 1.5 dB and for the subwoofers (15L to 16R) was about 0.2 dB. After compensation, this was reduced to about 0.05 dB for the satellites and about 0.09 dB for the subwoofers.

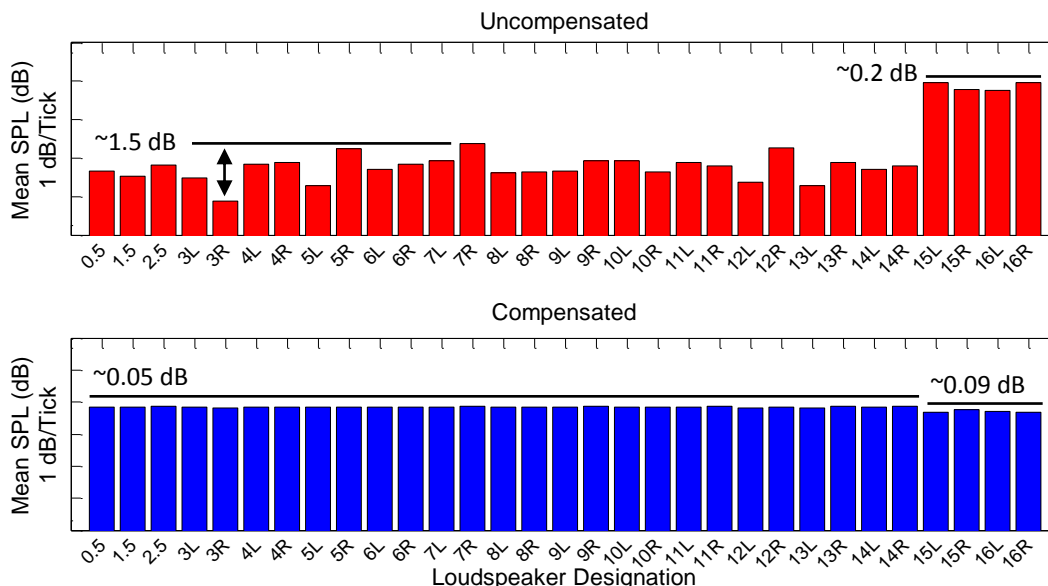

Figure 12: Uncompensated (top) and compensated (bottom) levels of the satellite (0.5 to 14R) and subwoofer (15L to 16R) loudspeakers.

5 Acoustic Performance

Tests of the EER sound-reproduction system were conducted to assess its acoustic performance. Assessments were made based on results of crossover performance, stationary and dynamic VBAP performance, maximum level, and spatial uniformity tests.

5.1 Crossover Performance

To test the crossover performance, a satellite and subwoofer loudspeaker pair was excited with pink noise compensated with the corresponding IIR equalization filters. The sound-reproduction system's capability of positioning a virtual source was not considered in this test. Hence, VBAP was disabled in this evaluation. The resulting responses within the 20 Hz – 12.5 kHz 1/3-octave bands are shown in Figure 13 for a single satellite loudspeaker 8R, a single subwoofer 15R), and the combined active pair. For each 1/3-octave band, the levels shown are the average obtained from two centrally located microphones. The plot reveals that no significant increase or decrease in level is observed at the crossover frequencies (80 Hz and 500 Hz) when both loudspeakers are active. Furthermore, the minimum-to-maximum level difference of the combined active pair is about 5.5 dB which is consistent with the individual loudspeaker compensation results reported in [11]. By conducting this test on other loudspeaker pairs, it was found that the crossover performance was comparable. The results of this test serve as a benchmark against which the subsequent stationary and dynamic results are compared.

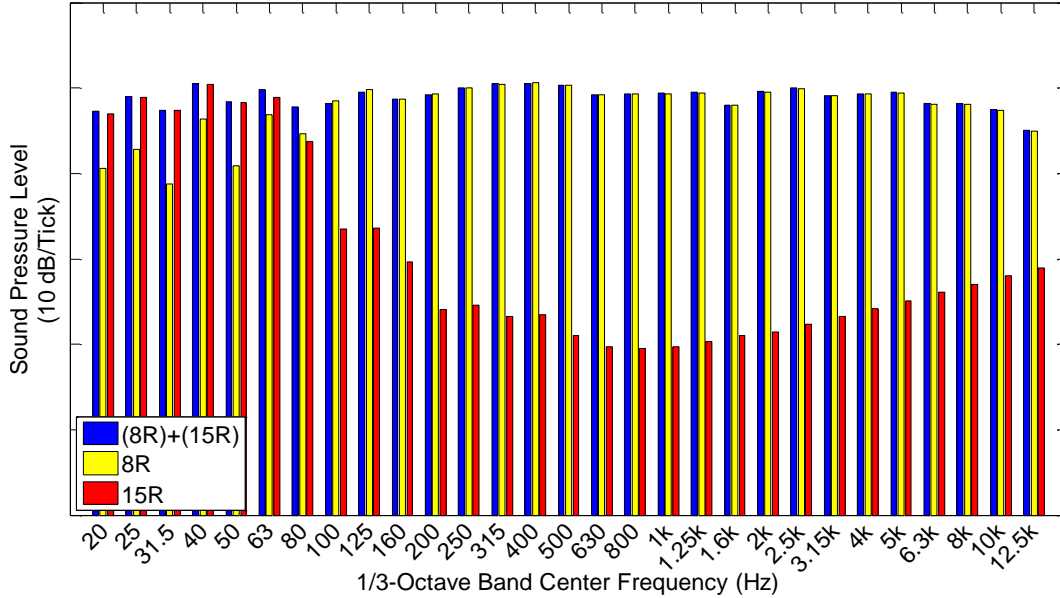

Figure 13: Typical results from the crossover performance test.

5.2 Stationary Performance

The stationary performance of the sound-reproduction system is defined here as the system’s ability to reproduce the desired magnitude response of a virtual source within a loudspeaker triplet. Hence, VBAP was enabled in this evaluation. For the test described here, three loudspeakers were used to create a virtual source within the loudspeaker triplet using equal gains for the loudspeakers. This was performed by sending the same signal to all loudspeakers, but with individual equalization filters and time delays applied. The individual compensated loudspeaker responses for satellite loudspeakers 0.5, 3L, and 3R and the compensated virtual source response are shown in Figure 14. For each 1/3-octave band, the levels shown are the average obtained from two centrally located microphones. A measure of the flatness of the recorded spectra is the minimum-to-maximum level difference, i.e. the difference between the minimum and maximum 1/3-octave band levels over the frequency range. The average level difference for the three individual satellite loudspeakers is 4.1 dB, while the level difference for the virtual source is about 6.3 dB. The increased level difference of the latter indicates that the compensation of the individual loudspeakers is better than the compensation of their combined output.

Ideally, the loudspeaker triplet should increase the sound pressure level to three times (9.5 dB) that of the individual loudspeakers. Over the frequency range shown, the average 1/3-octave band increase was 7.7 dB, with a minimum increase of 6.0 dB in the 12.5 kHz band, and a maximum increase of 9.1 dB in the 400 Hz band. The reduction is caused by differences between compensated responses of the individual loudspeakers. These may be in the form of differences in the magnitude and/or phase response between speakers, the latter giving rise to destructive interference. Note that similar behavior was observed in the responses measured at the individual microphones. Therefore, this behavior was not a result of averaging the two centrally located microphone responses. The narrowband responses of each loudspeaker forming the triplet, and their combined response are shown in Figure 15. Magnitude differences between speakers are seen over the entire frequency range. Although a minimum phase representation was selected in the IIR filter design, destructive interference is also likely to contribute, particularly at high frequencies where shorter wavelengths are more affected by phase differences. Results from other loudspeaker triplets are comparable. Improvement upon the combined response of the loudspeaker triplet is an area of interest in further investigations.

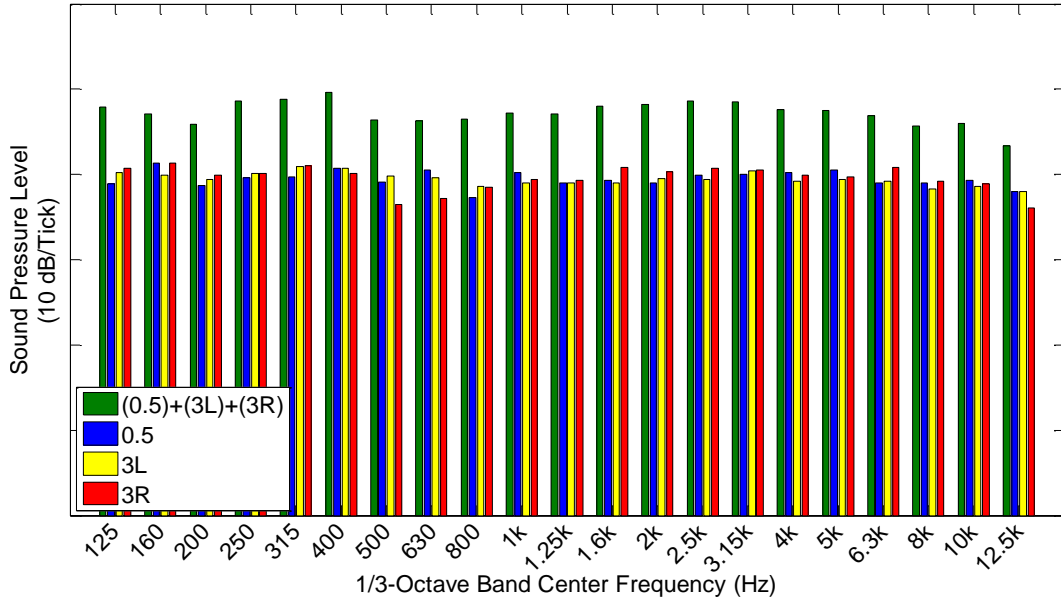

Figure 14: Typical stationary performance test results (broadband).

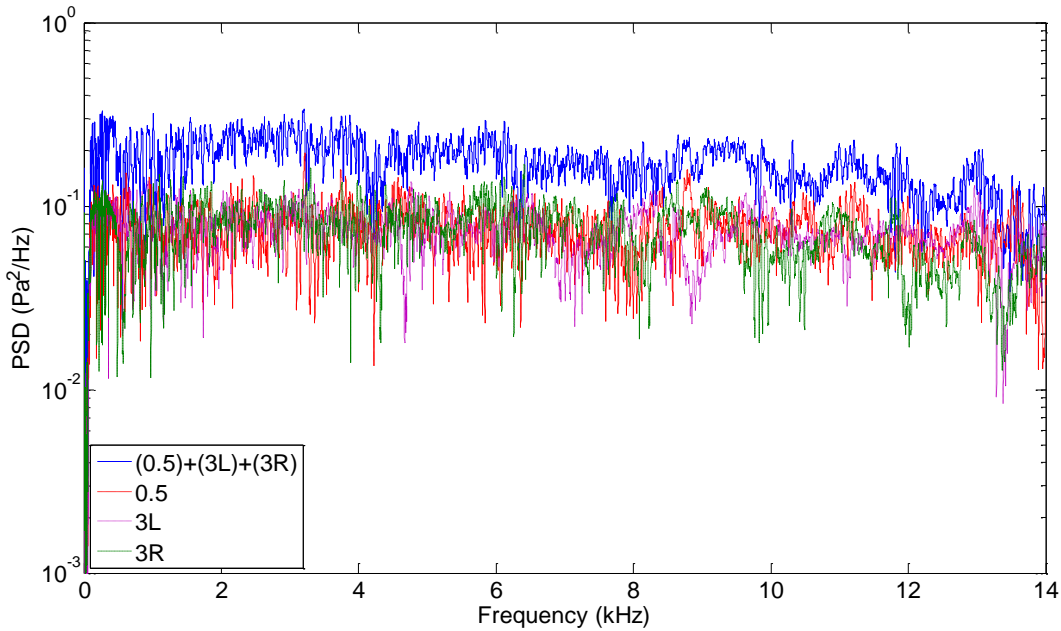

Figure 15: Typical stationary performance test results (narrowband).

5.3 Dynamic Performance

Considering that the location of virtual sources will generally be moving during an aircraft flyover simulation, it is of interest to analyze the dynamic performance of the real-time sound reproduction system, that is, the performance through the full DSP path indicated in Figure 4. For this evaluation, a virtual source was rotated 360° azimuthally around the EER, at three elevations, over a five-minute period. Figure 16 shows the uncompensated (left) and compensated (right) microphone responses of an orbiting source at elevations of 10°. Response measurement at elevation angles of 40° and 70° (not shown) were comparable. The levels shown are the average obtained from two centrally located microphones. For any given elevation and azimuth angle, the sound pressure level (relative to the mean) as a function of frequency is a measure of the flatness of the response. Analysis of the uncompensated

response indicates minimum-to-maximum level differences of about 25 dB (from +15 dB to -10 dB relative to the mean). This is largely attributable to the elevated subwoofer responses relative to the satellite responses. If the action of dynamically changing the virtual source position degrades the compensated performance, then the compensated response should have greater minimum-to-maximum level differences than the stationary case considered in the previous section. This is shown not to be the case as most level differences are about 6 dB (± 3 dB relative to the mean), which is comparable to the stationary case (6.3 dB). A slight trend toward increasing difference with increasing elevation angle was noted when comparing the respective compensated responses (not shown), although this effect is considered minor.

It is further interesting to note that the spectral shape of the compensated response at any particular elevation and azimuth angle bears resemblance to the stationary case. At lower frequencies, the response is, on average, higher than the mean and at higher frequencies the response is, on average, lower than the mean.

This test thus verifies that the compensated performance is not degraded by the action of dynamically changing the virtual source position.

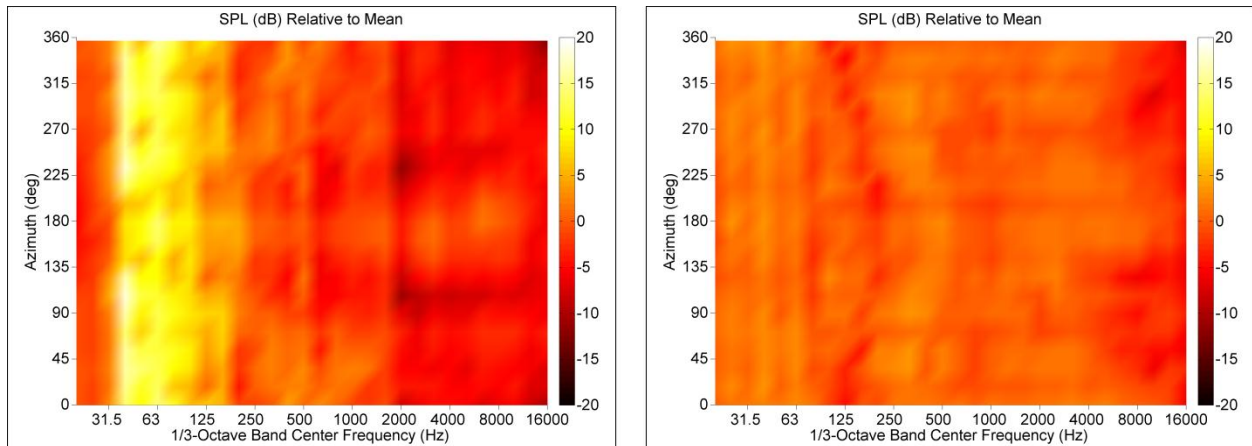

Figure 16: Uncompensated (left) and compensated (right) responses for an orbiting source at an elevation of 10° .

5.4 Maximum Spatialized SPL

The purpose of this test was to determine the maximum SPL the sound-reproduction system can produce from a single virtual source. The acoustic energy of the virtual source analyzed in this test was equivalent to a single satellite loudspeaker and a single subwoofer loudspeaker. The system was driven by band-limited (16 Hz – 10 kHz) pink noise and the responses were measured at the two centrally located microphones. The average uncompensated and compensated responses are shown in Figure 17. The maximum overall SPL was about 96.4 dB (or about 89.0 dBA) for the uncompensated response and about 80.4 dB (or about 79.2 dBA) for the compensated response. These results reflect the typical maximum overall SPL found at other virtual source locations. The reduction in compensated SPL can be attributed to several factors including reduction in subwoofer power when the equalization filters are applied, and power limitations of the satellite loudspeakers. Higher overall SPL can be achieved by reducing the frequency range of the excitation signal.

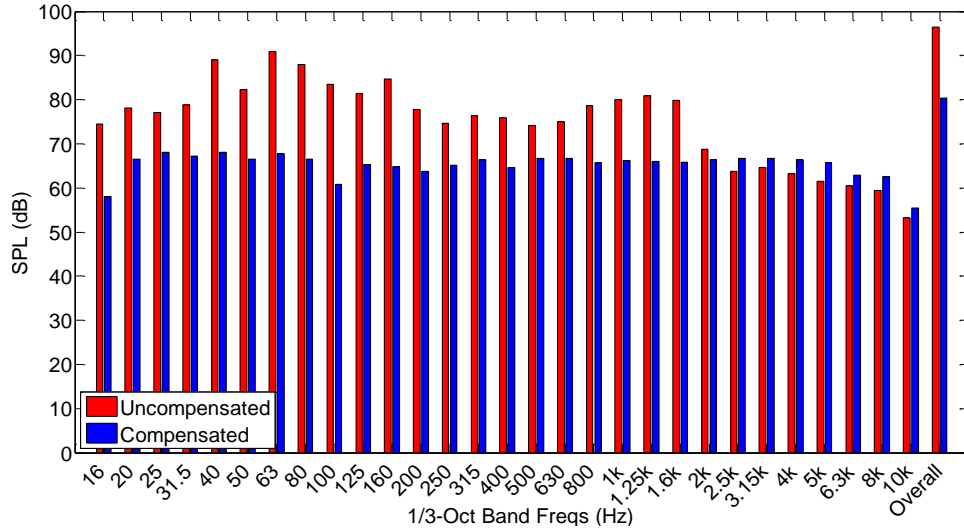

Figure 17: Uncompensated and compensated SPLs for a single virtual source.

5.5 Spatial Uniformity

A legacy mode of operation of the EER is for reproduction over only the ceiling loudspeakers. The test conducted here determined the spatial uniformity of the levels generated when all the ceiling loudspeakers (4L/R, 5L/R and 6L/R) are simultaneously active in a non-spatialized (non-VBAP) mode. The ceiling loudspeakers were driven by band-limited (16 Hz – 10 kHz) pink noise and the responses were measured at the seat locations indicated in Figure 18. One set of compensated responses was obtained for each IIR equalization configuration (i.e., one response set each for the two-microphone (top) or twelve-microphone (bottom) configurations (Figure 19)). The goal was to achieve an overall SPL variance within 1 dB at the seat locations. The actual variance achieved was within about 2 dB for the two-microphone equalization and within about 3 dB for the twelve-microphone equalization. The minimum-to-maximum 1/3-octave band level difference was about 16.5 dB for both equalizations, with a maximum variance within a single 1/3-octave band of about 11 dB for the two-microphone equalization and about 12.3 dB for the twelve-microphone equalization, both at the 160 Hz band.

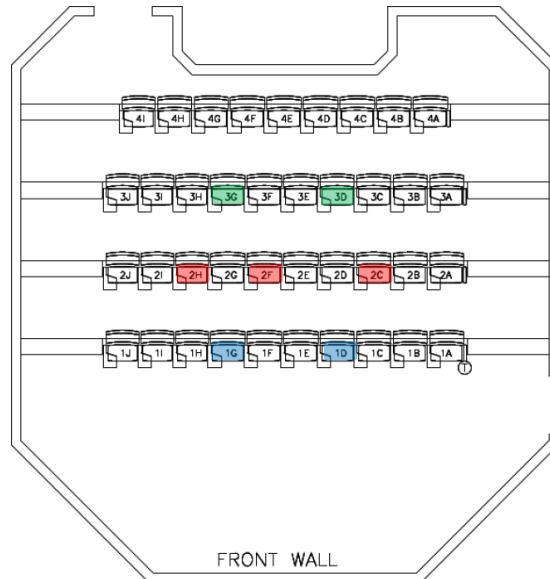

Figure 18: Aerial view of the EER with highlighted microphone locations.

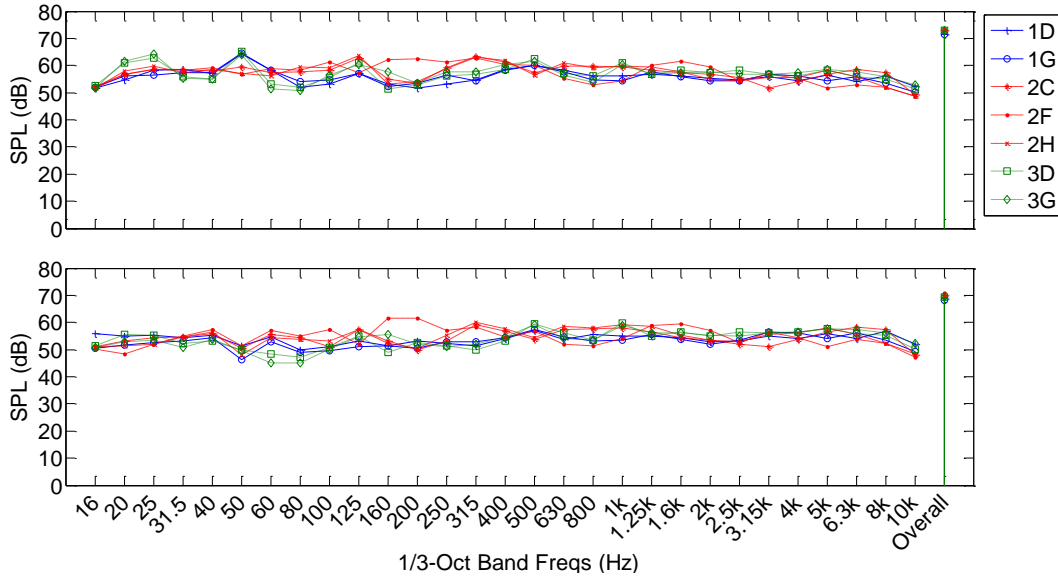

Figure 19: Compensated SPLs at various seat locations in the EER for a 2 microphone configuration (top) and a 12 microphone configuration (bottom).

6 Application Examples

As indicated in the introduction, the primary function of the EER is for conducting psychoacoustic studies of aircraft community noise through simulation of flyover events using recorded [24] or synthesized [25–27] aircraft noise. Two examples using flight test recordings are presented for straight and level flyovers. In both cases, the reproduced flyover noise was measured at two centrally located microphones.

In the first, a flyover of a Boeing 767 was simulated using a known trajectory and matching sideline recording made from a flight test at Wallops Island [28]. The flight test was conducted at very low altitude (400 feet above ground level (AGL)), so the recording was scaled to a level more representative of that encountered in the community. The top plot of Figure 20 shows the A-weighted SPL time history of recorded and reproduced flyover noise. Absolute gain calibration was performed by matching the A-weighted sound exposure level (SEL_A). Good agreement is seen above the EER noise floor of about 42 dBA.

In the second example, a flyover of a Mi-8 helicopter was simulated using a known trajectory and matching overhead recording made from a flight test at Eglin Air Force Base [29]. The recording was again scaled due to the low altitude (145 feet AGL) at which the test was conducted. The bottom plot of Figure 20 shows the C-weighted SPL time history of the recorded and reproduced flyover. C-weighting was used here to better represent the low frequency content of helicopter noise, and absolute gain calibration was performed by matching the C-weighted sound exposure level (SEL_C). Excellent agreement is seen above the EER noise floor of about 55 dBC.

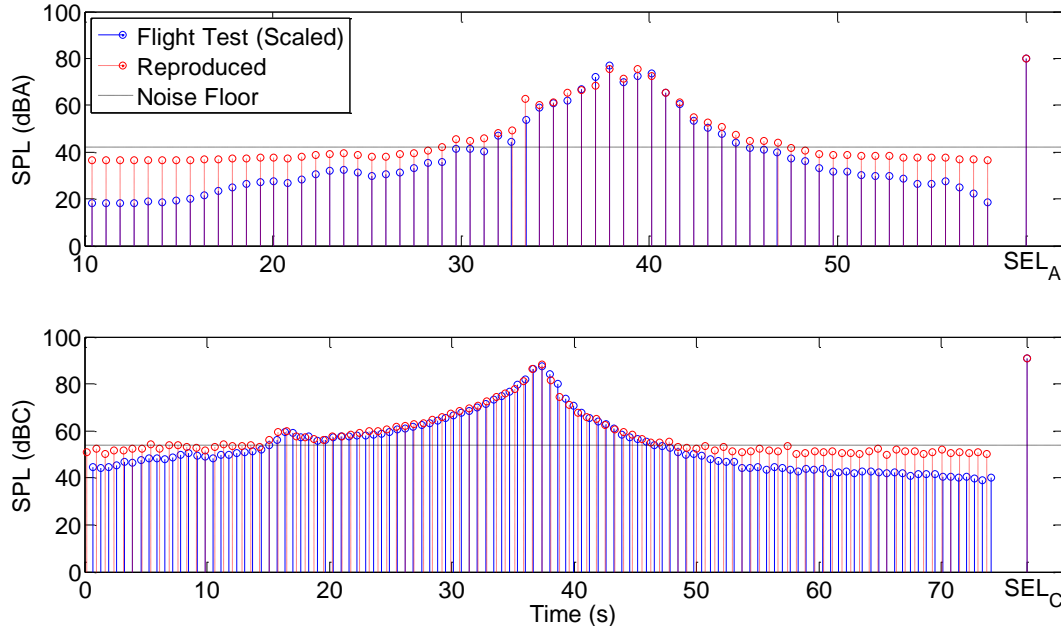

Figure 20: Comparison of the SPL time histories for the recorded and reproduced Boeing 767 (top, A-weighted) and Mi-8 helicopter (bottom, C-weighted) flyovers.

7 Concluding Remarks

The acoustic performance of the real-time three-dimensional sound-reproduction system employed in the NASA Langley Research Center Exterior Effects Room was evaluated. A method to generate lower order IIR equalization filters, as surrogates for the higher order Wiener FIR equalization filters, was developed and implemented. The achieved order reduction permitted operation of the IIR equalization filters in the real-time sound-reproduction system. The IIR equalization filters compensated for spectral colorization, relative gain, and full-path time delay. The performance of the compensated real-time system was demonstrated for stationary and dynamic source positions. Excellent comparisons of simulated flyovers with recordings demonstrated the unique capabilities of the Exterior Effects Room for conducting psychoacoustic tests of aircraft flyover noise.

Tests were also conducted to evaluate the system performance in other modes of operation. These included assessments of the maximum SPL and spatial uniformity. The maximum SPL for the compensated system was found to be flatter across 1/3-octave bands than the uncompensated response. However, the maximum level was reduced to accomplish this. In the overhead loudspeaker mode, the spatial uniformity across a typical seating area was found to be somewhat better when using the two-microphone equalization than when using the twelve-microphone equalization.

An area for improvement is in the approach taken for loudspeaker equalization. It was found that differences between the compensated responses within a loudspeaker triplet reduced the maximum possible level of a virtual source. A possible strategy to address that is to develop virtual source specific equalization, rather than the current approach employing equalization specific to individual loudspeakers. As with the VBAP gains, such equalizations could be pre-computed for a large but finite number of virtual sources at regularly spaced grid points. The filters could be dynamically changed during runtime to reflect the current virtual source position, however a strategy to select the nearest equalization would need to be employed to avoid the possibility of generating unstable IIR filters through interpolation. Changes to the current DSP architecture would be required to implement this approach. In addition, the effect of alternative phase representations used in the generation of the IIR equalization filters can be explored.

8 Appendix - Installed Speaker Locations

Speaker	x Location (m)*	y Location (m)*	z Location (m)*	Range (m)*
0.5	0.0135	4.8165	0.4886	4.8412
1.5	0.0050	4.1948	2.5288	4.8981
2.5	-0.0268	-2.9825	2.8451	4.1220
3L	-1.4782	4.5659	-1.0747	4.9181
3R	1.5034	4.5729	-1.0335	4.9234
4L	-1.4916	2.1578	3.3120	4.2250
4R	1.5068	2.1796	3.3205	4.2482
5L	-1.4986	-0.0118	3.5797	3.8807
5R	1.4853	-0.0393	3.5560	3.8539
6L	-1.5146	-2.6515	3.5236	4.6626
6R	1.4968	-2.6460	3.5248	4.6547
7L	-0.8095	-2.8625	0.5492	3.0250
7R	0.7874	-2.8578	0.5419	3.0134
8L	-2.2088	4.2239	1.3174	4.9453
8R	2.2504	4.2599	1.2846	4.9861
9L	-3.5835	2.9424	-1.0297	4.7497
9R	3.5776	3.0662	-1.0462	4.8265
10L	-3.4537	2.2867	2.8726	5.0407
10R	3.4401	2.3888	2.8828	5.0844
11L	-3.8790	0.6535	1.2083	4.1151
11R	3.8958	0.7291	1.1987	4.1407
12L	-3.8974	-1.4630	-0.0795	4.1637
12R	3.8767	-1.3999	-0.0549	4.1221
13L	-3.7039	-1.4203	3.2160	5.1067
13R	3.6912	-1.4383	3.2053	5.0958
14L	-3.3342	-3.3782	1.8645	5.0996
14R	3.3339	-3.3407	1.8803	5.0804
15L	-2.5341	4.4176	-0.8461	5.1626
15R	2.4189	4.6150	-0.8515	5.2796
16L	-3.6358	-3.5071	0.4623	5.0727
16R	3.6451	-3.4606	0.4500	5.0463

* Dimensions are relative to the center microphone location (see Figure 2).

9 References

- [1] K. P. Shepherd, “The Subjective Evaluation of Noise from Light Aircraft,” *NASA CR-2773*, 1976.
- [2] D. A. McCurdy and C. A. Powell, “Effects of Duration and Other Noise Characteristics on the Annoyance Caused by Aircraft-Flyover Noise,” *NASA TP-1386*, 1979.
- [3] D. A. McCurdy, “Effects of Sound Level Fluctuations on Annoyance Caused by Aircraft-Flyover Noise,” *NASA TP-1576*, 1979.
- [4] D. A. McCurdy and C. A. Powell, “Annoyance Caused by Propeller Airplane Flyover Noise,” *NASA TP-2356*, 1984.
- [5] D. A. McCurdy, “Annoyance Caused by Advanced Turboprop Aircraft Flyover Noise, Single-Rotating-Propeller Configuration,” *NASA TP-2782*, 1988.
- [6] J. D. Leatherwood and B. M. Sullivan, “A Laboratory Study of Subjective Annoyance Response to Sonic Booms and Aircraft Flyovers,” *NASA TM-109113*, 1994.
- [7] V. Pulkki, “Virtual Sound Source Positioning Using Vector Base Amplitude Panning,” *Journal of the Audio Engineering Society (JAES)*, vol. 45, no. 6, pp. 456–466, 1997.
- [8] V. Pulkki, “Spatial Sound Generation and Perception by Amplitude Panning Techniques,” *Helsinki University of Technology, Helsinki, Finland, Tech. Rep*, 2001.
- [9] J. Busby et al., “3D Model and Tutorial Shop: Free 3D Head Scan Model,” *Ten24*, 2010. [Online]. Available: <http://www.ten24.info/index.php/shop/3d-head-scans/free-3d-head-scan-model-52/>. [Accessed: 10-Dec-2012].
- [10] AuSIM Inc., “Corporate Website,” 2012. [Online]. Available: <http://www.ausim3d.com/>. [Accessed: 10-Dec-2012].
- [11] K. J. Faller II et al., “Acoustic Performance of an Installed Real-Time Three-Dimensional Audio System,” in *Proceedings of Meetings on Acoustics (POMA)*, 2011, vol. 11.
- [12] S. J. Elliott et al., “Practical Implementation of Low-Frequency Equalization Using Adaptive Digital Filters,” *Journal of the Audio Engineering Society (JAES)*, vol. 42, no. 12, pp. 988–998, 1994.
- [13] M. Karjalainen and T. Paatero, “Equalization of Loudspeaker and Room Responses Using Kautz Filters: Direct Least Squares Design,” *EURASIP Journal on Advances in Signal Processing*, vol. 2007, pp. 1–14, 2007.
- [14] S. J. Elliott and P. A. Nelson, “Multiple-Point Equalization in a Room Using Adaptive Digital Filters,” *Journal of the Audio Engineering Society (JAES)*, vol. 37, no. 11, pp. 899–907, 1989.
- [15] B. Musicus, “Levinson and Fast Choleski Algorithms for Toeplitz and Almost Toeplitz Matrices,” *MIT RLE Technical Report*, no. 538, 1988.
- [16] S. H. Linkwitz, “Active Crossover Networks for Noncoincident Drivers,” *Journal of the Audio Engineering Society (JAES)*, vol. 24, no. 1, pp. 2–8, 1976.

- [17] E. Winer, *The Audio Expert: Everything You Need to Know About Audio*. Waltham, MA: Focal Press, 2012, p. 696.
- [18] K. J. Faller II et al., “Acoustic Calibration of the Exterior Effects Room at the NASA Langley Research Center,” in *Proceedings of Meetings on Acoustics (POMA)*, 2010, vol. 9.
- [19] J. E. Dennis and R. B. Schnabel, *Numerical Methods for Unconstrained Optimization and Nonlinear Equations*. Englewood Cliffs, NJ: Prentice-Hall, 1983, p. 394.
- [20] A. V. Oppenheim and R. W. Schaffer, *Digital Signal Processing*. Englewood Cliffs, NJ: Prentice-Hall, 1975, p. 585.
- [21] J. Proakis and D. Manolakis, “Quantization of Filter Coefficients,” in *Digital Signal Processing: Principles, Algorithms and Applications*, 3rd ed., Upper Saddle River, NJ: Prentice-Hall, 2005, pp. 569–582.
- [22] Intel Inc., “Intel Integrated Performance Primitives (IPP®),” 2012. [Online]. Available: <http://software.intel.com/en-us/articles/intel-ipp/>. [Accessed: 10-Dec-2012].
- [23] X. Fiss and A. Kwasinski, “Automatic Real-Time Electric Guitar Audio Transcription,” in *IEEE International Conference on Acoustics, Speech and Signal Processing (ICASSP)*, 2011, pp. 373–376.
- [24] S. A. Rizzi and B. M. Sullivan, “A Three-Dimensional Virtual Simulator for Aircraft Flyover Presentation,” *International Conference on Auditory Display (ICAD), Boston, MA*, pp. 87–90, 2003.
- [25] M. Arntzen et al., “A Framework for Simulation of Aircraft Flyover Noise Through a Non-Standard Atmosphere,” *18th AIAA/CEAS Aeroacoustics Conference, Colorado Springs, CO*, 2012.
- [26] S. A. Rizzi, B. M. Sullivan, and A. R. Aumann, “Recent Developments in Aircraft Flyover Noise Simulation at NASA Langley Research Center,” *NATO/AVT TG 158 Specialists’ Meeting on Environmental Noise Issues Associated with Gas Turbine Powered Military Vehicles*, pp. 17–1 to 17–14, 2008.
- [27] S. A. Rizzi and B. M. Sullivan, “Synthesis of Virtual Environments for Aircraft Community Noise Impact Studies,” *11th AIAA/CEAS Aeroacoustics Conference, AIAA 2005-2983, Monterey, CA*, 2005.
- [28] G. Fleming et al., “Engine Installation Effects of Four Civil Transport Airplanes: Wallops Flight Facility Study,” *NASA TM-2003-212433*.
- [29] M. E. Watts, D. A. Conner, and C. D. Smith, “Joint Eglin Acoustics Week III Data Report,” *NASA/TM-2010-216206*.

REPORT DOCUMENTATION PAGE

*Form Approved
OMB No. 0704-0188*

The public reporting burden for this collection of information is estimated to average 1 hour per response, including the time for reviewing instructions, searching existing data sources, gathering and maintaining the data needed, and completing and reviewing the collection of information. Send comments regarding this burden estimate or any other aspect of this collection of information, including suggestions for reducing this burden, to Department of Defense, Washington Headquarters Services, Directorate for Information Operations and Reports (0704-0188), 1215 Jefferson Davis Highway, Suite 1204, Arlington, VA 22202-4302. Respondents should be aware that notwithstanding any other provision of law, no person shall be subject to any penalty for failing to comply with a collection of information if it does not display a currently valid OMB control number.
PLEASE DO NOT RETURN YOUR FORM TO THE ABOVE ADDRESS.

1. REPORT DATE (DD-MM-YYYY) 01-06-2013		2. REPORT TYPE Technical Memorandum		3. DATES COVERED (From - To)	
4. TITLE AND SUBTITLE Acoustic Performance of a Real-Time Three-Dimensional Sound-Reproduction System				5a. CONTRACT NUMBER	
				5b. GRANT NUMBER	
				5c. PROGRAM ELEMENT NUMBER	
6. AUTHOR(S) Faller, Kenneth J., II; Rizzi, Stephen A.; Aumann, Aric R.				5d. PROJECT NUMBER	
				5e. TASK NUMBER	
				5f. WORK UNIT NUMBER 877868.02.07.07.04.02.01	
7. PERFORMING ORGANIZATION NAME(S) AND ADDRESS(ES) NASA Langley Research Center Hampton, VA 23681-2199				8. PERFORMING ORGANIZATION REPORT NUMBER L-20271	
9. SPONSORING/MONITORING AGENCY NAME(S) AND ADDRESS(ES) National Aeronautics and Space Administration Washington, DC 20546-0001				10. SPONSOR/MONITOR'S ACRONYM(S) NASA	
				11. SPONSOR/MONITOR'S REPORT NUMBER(S) NASA/TM-2013-218004	
12. DISTRIBUTION/AVAILABILITY STATEMENT Unclassified - Unlimited Subject Category 71 Availability: NASA CASI (443) 757-5802					
13. SUPPLEMENTARY NOTES					
14. ABSTRACT The Exterior Effects Room (EER) is a 39-seat auditorium at the NASA Langley Research Center and was built to support psychoacoustic studies of aircraft community noise. The EER has a real-time simulation environment which includes a three-dimensional sound-reproduction system. This system requires real-time application of equalization filters to compensate for spectral coloration of the sound reproduction due to installation and room effects. This paper describes the efforts taken to develop the equalization filters for use in the real-time sound-reproduction system and the subsequent analysis of the system's acoustic performance. The acoustic performance of the compensated and uncompensated sound-reproduction system is assessed for its crossover performance, its performance under stationary and dynamic conditions, the maximum spatialized sound pressure level it can produce from a single virtual source, and for the spatial uniformity of a generated sound field. Additionally, application examples are given to illustrate the compensated sound-reproduction system performance using recorded aircraft flyovers.					
15. SUBJECT TERMS Acoustic performance; Digital equalization filters; Real-time sound reproduction system; Three-dimensional sound simulation; Vector-base amplitude panning (VBAP)					
16. SECURITY CLASSIFICATION OF:			17. LIMITATION OF ABSTRACT	18. NUMBER OF PAGES	19a. NAME OF RESPONSIBLE PERSON
a. REPORT	b. ABSTRACT	c. THIS PAGE			STI Help Desk (email: help@sti.nasa.gov)
U	U	U	UU	28	19b. TELEPHONE NUMBER (Include area code) (443) 757-5802