

# IMPACT FOAM TESTING FOR MULTI-MISSION EARTH ENTRY VEHICLE APPLICATIONS

Louis Glaab, \*Parul Agrawal, \*\*James Hawbaker

*NASA-Langley Research Center  
e-mail: Louis.J.Glaab@nasa.gov*

*\*NASA-Ames Research Center/ERC, Incorporated*

*\*\* Southern Research Institute*

## ABSTRACT

Multi-Mission Earth Entry Vehicles (MMEEVs) are blunt-body vehicles designed with the purpose of transporting payloads from outer space to the surface of the Earth. To achieve high-reliability and minimum weight, MMEEVs avoid use of limited-reliability systems, such as parachutes and retro-rockets, instead using built-in impact attenuators to absorb energy remaining at impact to meet landing loads requirements. In the current effort, two different Rohacell foams were tested to determine their thermal conductivity in support of MMEEV design applications. These applications include thermal insulation during atmospheric entry, impact attenuation, and post-impact thermal insulation. Results indicate that for these closed-cell foams, the effect of impact is limited on thermal conductivity due to the venting of the virgin material gas and subsequent ambient air replacement. In addition, thermal conductivity results indicate a variation with temperature and are higher than manufacturer's specifications.

## 1. SYMBOLS

EDL	Entry, Descent, and Landing
FE	Finite Element
ksi	Thousands of pounds per square inch
PMI	polymethacrylimide
MSR	Mars Sample Return
MMEEV	Multi-Mission Earth Entry Vehicle
M-SAPE	Multi-Mission System Analysis for Planetary Entry, Descent, and Landing tool
%/s	Rate of strain in percent per second
PMI	Polymethacrylimide type of foam
RCS	Reaction Control System

$\sigma_{cs}$	Compressive strength
$\sigma_{ss}$	Shear strength
SRI	Southern Research Institute
$T_d$	Distortion temperature

## 2. INTRODUCTION

Multi-Mission Earth Entry Vehicles (MMEEVs) are designed to transport payloads from outside of the atmosphere to the surface of the Earth. They serve as the last leg of missions to gather samples from around the solar system for detailed analysis on Earth. Multi-Mission Earth Entry Vehicles can have various sizes, shapes, designs, and concept of operations that reflect unique mission requirements. In general, however, many of the prior and planned future MMEEVs can be viewed as a class of vehicle with many similar characteristics. Usually, MMEEVs have high speeds resulting from direct atmospheric entries. In addition, many MMEEVs adopt what is known as a single-stage entry concept that does not include parachutes, retro-rockets, or reaction control systems (RCS) for example, in order to minimize complexity and weight while maximizing reliability. Energy remaining at impact is absorbed by built-in attenuation systems [1]. Given the unguided nature of their flight after release from the carrier vehicle, MMEEVs can have a large landing footprint that can lead to long recovery times.

Prior to impact, the impact attenuator foam is assumed to be in its' virgin condition. However, during impact the foam compresses as energy is absorbed into the foam during the deceleration of the payload. During this process two changes occur to the impact attenuator material: 1) the closed-cells of the foam rupture, venting gases embedded into the foam during manufacturing with the remaining foam increasing in density, and 2) the foam crushes significantly from its' initial dimension. Typically the impact attenuator foam crushes to approximately 30% to 40% of its'

original thickness during nominal impact payload decelerations. Both of these changes can influence the thermal analysis of the vehicle after impact.

Thermal soak involves the process of the energy stored in the heat-shield during re-entry flowing into the vehicle and payload after impact and before vehicle recovery can be performed. The length of time required for recovery can be on the order of several hours or even days. As a result, the maximum payload temperature will likely occur after impact and that effective thermal modeling needs to adequately model the state of the vehicle. Figure 1 illustrates a NASA-LaRC concept for an EEV for Mars Sample Return (MSR).

To assess vehicle designs for multiple missions, as well as develop advanced integrated multi-disciplinary automated design tools, the Multi-Mission Systems Analysis for Planetary Entry (M-SAPE) tool is being developed and enhanced. The Multi-Mission Systems Analysis for Planetary Entry parametric design tool is used to facilitate the design of MMEEVs for an array of missions and develop and visualize the trade space. The integrated system improves the performance of the systems analysis team by automating and streamlining the EDL system engineering process. The M-SAPE tool [2] improves and speeds up the design activities such as trade studies, sensitivity analyses, Monte Carlo analyses, and vehicle optimization.

In 2012, ground testing to validate and expand design trade space coverage for M-SAPE models was performed. Ongoing activities include impact testing and thermal characterization of Rohacell foams, which inform both the structural response models and the thermal soak models in M-SAPE. The goal of thermal soak modeling is to show how the MMEEVs will behave thermally after impact on Earth, and assess whether this will be a design driver.

Thermal soak analysis conducted to date indicates that the payload temperature rises after impact and can exceed design requirements potentially becoming a design driving result [3]. To support thermal soak analyses, an effort was undertaken to improve the modeling fidelity of the thermal soak models. One key element of those models is the thermal conductivity of the impact foam during all phases of the MMEEV mission, especially during post impact. Manufacturers' specifications are available for virgin foam, but the thermal conductivity of the foam in a post-impact condition was unknown. In addition, temperature effects on thermal conductivity for the virgin and impacted foams were not known to a high degree of confidence. Testing, performed by Southern Research Institute (SRI), was conducted on candidate impact

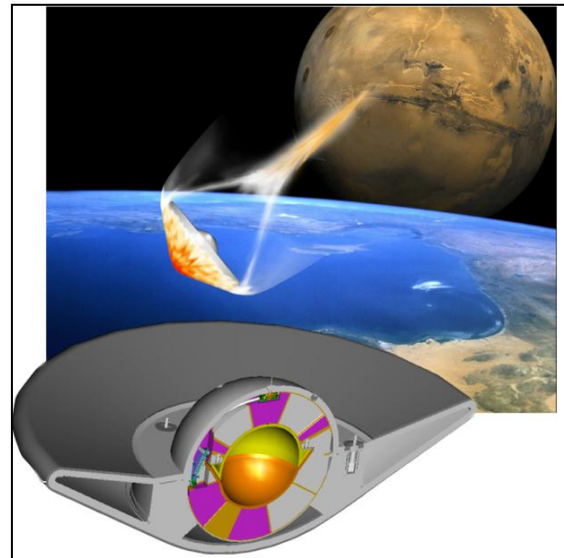

Figure 1 - NASA LaRC MMEEV concept.

attenuator foams to significantly improve the validity of the thermal soak analysis for MMEEVs. This testing included virgin and crushed foam samples and spanned a range of temperatures applicable to MMEEV applications.

### 3. APPARATUS

For this test SRI's 7-inch guarded hot plate test apparatus was used. This apparatus, shown in Figure 2, is based on ASTM C177-97 specification [4]. The unit is capable of obtaining conductivity values in the temperature range of  $-200^{\circ}\text{F}$  to  $500^{\circ}\text{F}$  ( $-129$  to  $260^{\circ}\text{C}$ ). Examples of materials that are tested using this apparatus are insulating foams, graphite foams and fibrous insulations, low density ceramic insulations, cloths and rubbers.

The guarded hot plate apparatus consists of a central heater plate surrounded by a guard heater, each separately controlled. The guard ring is maintained at the same temperature as the central heater so that all of the heat flow is normal to the specimen surfaces. The temperature differences between the guard and central sections are measured by means of differential thermocouple junctions connected in series. The 7-inch apparatus contains eight differential junctions.

The heater plate is sandwiched between layers of interfacial material, the hot-face thermocouples, the specimen, cold-face thermocouples, interfacial material, and finally a cold source to dissipate the heat. In addition to the thermocouples in contact with the specimen, thermocouples are located in the central heater and the outer copper cold plates. Figure 2 shows a schematic of a typical hot plate apparatus.

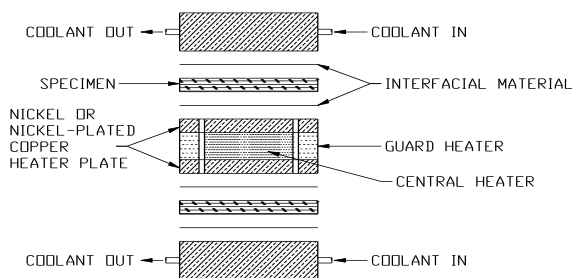

Figure 3 - Guarded hot plate apparatus schematic.

To provide intimate contact at all interfaces, the entire sandwich assembly was pressed firmly together by a load of 200 lbs. Since the foam samples were fragile, spacers were used to maintain specimen thickness to maintain a fixed distance between the heater and the cold plate. Water was circulated through the cooling section to achieve test temperatures higher than room temperature. Equilibrium conditions were obtained before readings were taken.

#### 4. FOAMS SELECTED

Two different Rohacell foams were used in the current dynamic analysis. Rohacell, a closed-cell polymethacrylimide (PMI) foam, was chosen for the current effort because of its prevalent use in the space and aviation industry and its use for structure impact attenuation. In the aerospace industry, Rohacell is used in Boeing’s Delta II, III, and IV rockets for noise attenuation and in the pressure bulkhead of Airbus’ A380 and A340 [5]. Both the 71-WFHT and 100-XTHT foams are attractive for MMEEV impact attenuator applications providing reasonable acceleration loads for a range of MMEEV payloads as illustrated in [6]. The 71-WFHT and 110-XTHT foams selected exhibit nearly ideal crush response and high compressive strength to weight ratios. Figures 3 and 4

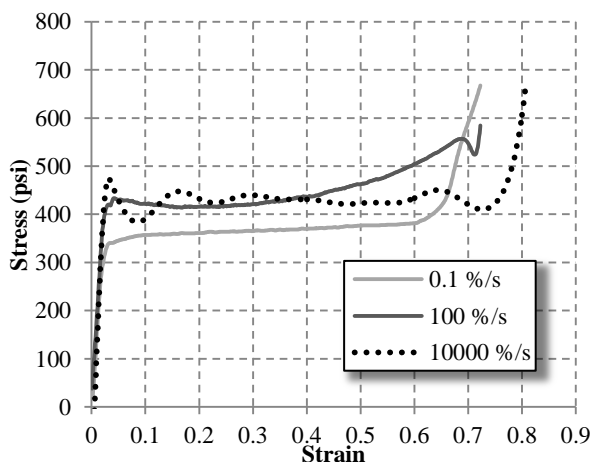

Figure 4-Mechanical properties of the 71-WFHT foam.

from [5] provide the mechanical stress-strain properties for the 71-WFHT and 110-XTHT foams for a range of strange rates, respectively. Table 1 provides the foam

types selected, advertised density, compressive strength, shear strength, and the heat distortion temperature. The 110-XTHT has an additional benefit of providing a higher distortion temperature due to an additional heat-treatment manufacturing step. It is necessary to investigate foams with a higher temperature tolerance due to the potential for high temperatures prevalent in MMEEV designs during the EDL phase.

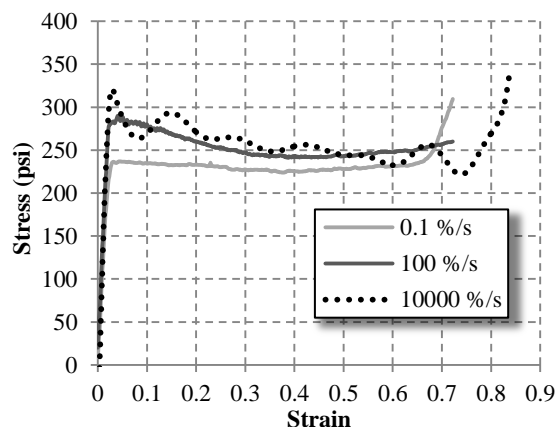

Figure 2 - Mechanical properties of the 110-XTHT foam.

Table 1 - Rohacell Foams Tested

#	Foam	Density	$\sigma_{cs}$	$\sigma_{ss}$	$T_d$
		slugs/ft <sup>3</sup>	ksi	ksi	°F
1	71-WFHT	0.15	0.25	0.19	392
2	110-XTHT	0.21	0.52	0.35	464

#### 5. SAMPLES

Test samples were constructed for the 71-WFHT and 110-XTHT foams in both the virgin and crushed conditions. Samples were constructed to be 0.250” thick. Thermocouples consisting of 0.005” diameter wire in a 0.040” double bore alumina tube were used. The thermocouple was then electrically insulated with 0.003” Teflon tape. Connecting the wires to a small metal square called a “getter” makes the junction. The Teflon insulated leads were sandwiched between the specimen and filler material. This arrangement insures that there is no air film between the specimen and thermocouples, and that good, intimate contact exists at all interfaces. Figure 5 displays a schematic of the specimens manufactured for this test.

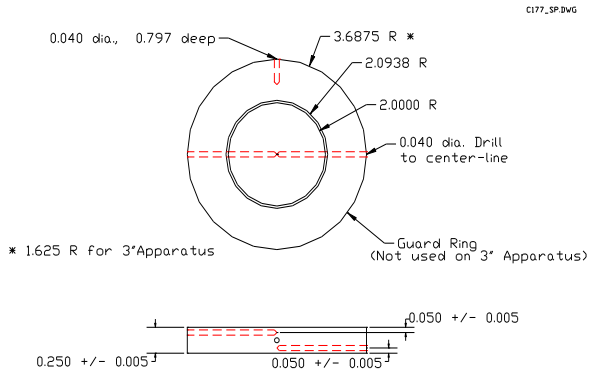

Figure 5 - Typical 0.250" specimen design.

## 6. TEST MATRIX

The test matrix for foam thermal conductivity testing is provided in Table 2. During impact, the foam absorbs and dissipates energy as a result of crushing. After impact, the amount of remaining foam is much less than what existed before impact. In general, optimal crush strokes on the order of 60 to 80% are encountered for MMEEV designs. In order to determine the effect the impact attenuation, and provide adequate data for post-impact thermal soak modelling, foam samples were tested in both their virgin and crushed states.

Table 2 - Test Matrix

#	Foam	Condition	Test Pressure	Temperatures tested
1	71 WFHT	Virgin	1 ATM	Multiple
2	71 WFHT	Virgin	Vacuum	Single
3	71 WFHT	Crushed	1 ATM	Multiple
4	71 WFHT	Crushed	Vacuum	Multiple
5	110 XTHT	Virgin	1 ATM	Multiple
6	110 XTHT	Virgin	Vacuum	Single Temp
7	110 XTHT	Crushed	1 ATM	Multiple
8	110 XTHT	Crushed	Vacuum	Multiple

For this test, virgin foam was crushed to ~80% of its initial size to form test samples. In order to investigate the effect of crushing further, several test conditions were defined to evaluate the effect of vacuum on the test samples. Since Rohacell is a closed-cell foam, it was assumed that vacuum effects would be minimal for the virgin condition. As a result, only a single temperature point was acquired for the virgin foam

under a vacuum. All the other test conditions employed a total of 3 evenly distributed temperature points that ranged from 104 °F (40 °C) up to approximately 320 °F (160 °C).

## 7. THERMAL CONDUCTIVITY RESULTS

Results from the thermal conductivity testing for the 71-WFHT and 110-XTHT foams, for both the virgin and crushed, and 1 atm and vacuum, conditions are presented in Figures 6 and 7, respectively.

From Figure 6 it can be seen that the 1 atm results for the virgin and crushed 71-WFHT foam samples were similar to each other over the range of temperatures

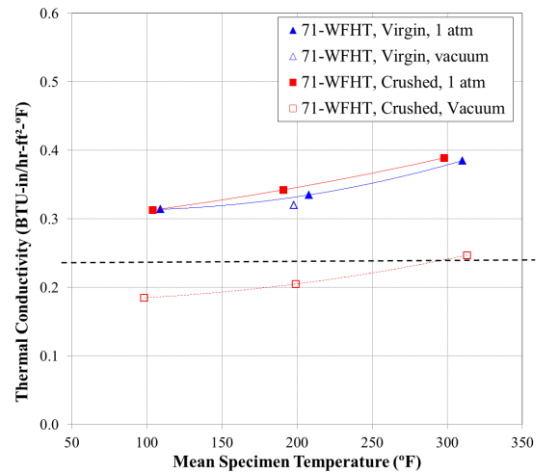

Figure 6: 71-WFHT thermal conductivity results.

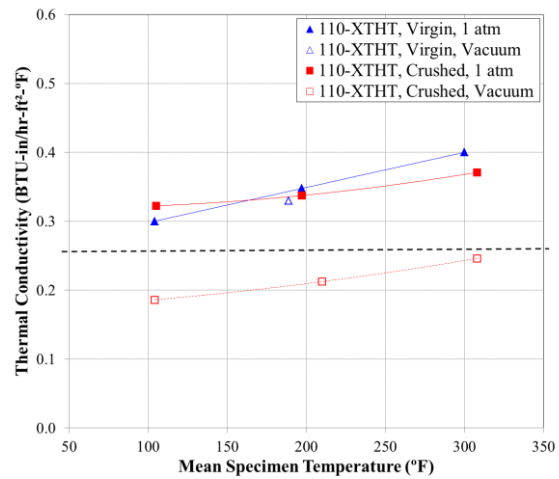

Figure 7: 110-XTHT thermal conductivity results.

tested. This result is considered counterintuitive since the density of the 71-WFHT crushed foam increased approximately 200% compared to the virgin foam (i.e., 0.0811 g/cm<sup>3</sup> to 0.1613 g/cm<sup>3</sup> for the virgin and crushed foams, respectively).

To investigate the lack of change in thermal conductivity due to crushing, both the virgin and crushed foam samples were tested in a vacuum. Since the cell walls of the 71-WFHT were strong enough to withstand the force from the vacuum without rupturing,



the thermal conductivity was not affected by the change in atmospheric pressure as shown in Figure 6. However, when the crushed foam was tested in a vacuum, the thermal conductivity results were decreased substantially. Figures 8 and 9 show example magnified images of the 110-WFHT foam which is similar to both the 71-WFHT and 110-XTHT foams, but was not tested in this effort due to budget reasons. As can be seen in Figure 8, the cells are closed for the virgin foam condition. It can also be seen that most of the foam cells ruptured during crushing, as shown in Figure 9, and that the gas in the cells created during manufacturing has been released. These open cells then allowed air to fill the cells and replace the manufacturing gas. It is assumed that the manufacturing gas is much more conductive than air such that even when the density was increased by 200%, the overall thermal conductivity was not affected by crushing.

It can also be seen in Figure 6 that the thermal conductivity of the virgin and crushed 71-WFHT foam samples increased with temperature ranging from approximately 0.31 to 0.39 BTU-in/hr-ft<sup>2</sup>°F. Prior to testing the only thermal conductivity data available for the 71-WFHT and 110-XTHT foams were from the manufacturer's specification, which was 0.222 and 0.263 BTU-in/hr-ft<sup>2</sup>°F for the 71-WFHT and 110-XTHT foams, respectively. The dashed lines on Figures 6 and 7 indicate the manufacturer's specification. Comparing the measured data to the dashed line indicate a difference of approximately 30% at lower temperatures and up to 64% at the higher temperatures. Similar results were observed for the 110-XTHT foam samples.

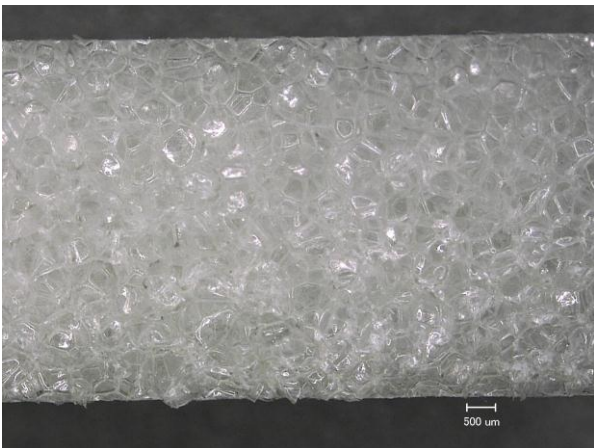

Figure 8 - Image of virgin 110-WFHT foam.



Figure 9- Image of crushed 110-WFHT foam.

## 8. SUMMARY

Multi-Mission Earth Entry Vehicles are designed to transport samples from outside the Earth's atmosphere to the planet's surface. Their design employs a single-stage entry concept that employs impact attenuators to absorb energy remaining at impact and mitigate payload decelerations. Several promising impact attenuator candidate foams have been identified. Prior MMEEV thermal analysis performed indicate that the maximum payload temperature can occur after vehicle impact. This is due to the heat, stored in the vehicle's heat-shield during entry, flowing into vehicle during the time after impact and before recover can be accomplished.

In support of high-fidelity thermal analysis, thermal conductivity testing of candidate foams has been accomplished. Given the likelihood that maximum payload temperatures can occur after impact, testing of the impact attenuator foams needed to include both the pre- and post-impact condition.

Foam samples were tested at Southern Research Institute using their 7" guarded hot plate apparatus to support MMEEV thermal analysis. Conditions tested included both virgin and crushed foam samples to address the pre- and post-impact foam conditions. Temperature ranges tested ranged from near the thermal distortion temperature of the foams down to approximately room temperature.

Results indicate that the thermal conductivity of the foams are essentially unchanged due impact. This is likely due to the venting of the gas, trapped inside the foam cells during manufacturing, and the replacement of that gas with air during the crushing process. It is hypothesized that the manufacturing gas is much more conductive than air such that the overall thermal conductivity is unchanged due to impact even though the post-impact foam samples were 200% more dense than the virgin samples. However, the impact foam's size changes greatly due to impact and needs to be modeled for effective thermal analysis. In addition,

thermal conductivity results indicate a substantial effect of temperature across the conditions tested.

## 9. ACKNOWLEDGEMENTS

The authors would like to acknowledge the help of Bhavesh Patel and John Koenig at SRI for their help with this effort.

## 10. REFERENCES

1. Mitcheltree, R.; Hughes, S.; Dillman, R.; Teter J.: *An Earth Entry Vehicle for Returning Samples from Mars*, 2<sup>nd</sup> International Symposium on Atmospheric Reentry Vehicles and Systems, Arcachon France, 2001.
2. Samareh, J. A., Maddock, R. W., and Winski, R. G., *An Integrated Tool for System Analysis of Sample Return Vehicles*, 2012 IEEE Aerospace Conference, Big Sky, Montana, March 3-10, 2012.
3. Agrawal P., Sepka S., Aliaga J., Venkatapathy E. and Samareh J., *Thermal Soak Analysis of Earth Entry Vehicles*, AIAA 2012-3010, 43<sup>rd</sup> AIAA Thermophysics Conference, New Orleans, LA, June 2012.
4. *Standard Test Method for Steady-State Heat Flux Measurements and Thermal Transmission Properties by Means of the Guarded-Hot-Plate Apparatus*. ASTM C 177-97.
5. Evonik Industries. (2012, July) *Rohacell WF foam properties*.
6. Patterson, Byron W.; Glaab, Louis J.: *Uniform Foam Crush Testing for Multi-Mission Earth Entry Vehicle Impact Attenuation*, NASTA/TM-2012—217763.