

Ongoing Development of a Series Bosch Reactor System

Morgan B. Abney¹ and J. Matthew Mansell²

NASA Marshall Space Flight Center, Huntsville, Alabama, 35812

Christine Stanley³

ESSSA, Marshall Space Flight Center, Huntsville, Alabama, 35812

Jennifer Edmunson⁴

BAE Systems, Huntsville, Alabama, 35806

Samuel J. DuMez⁵

Iowa State University, Ames, IA, 50011

and

Kevin Chen⁶

Embry-Riddle Aeronautical University – Daytona Beach, Daytona Beach, FL 32114

Future manned missions to deep space or planetary surfaces will undoubtedly incorporate highly robust, efficient, and regenerable life support systems that require minimal consumables. To meet this requirement, NASA continues to explore a Bosch-based carbon dioxide reduction system to recover oxygen from CO₂. In order to improve the equivalent system mass of Bosch systems, we seek to design and test a “Series Bosch” system in which two reactors in series are optimized for the two steps of the reaction, as well as to explore the use of *in situ* materials as carbon deposition catalysts. Here we report recent developments in this effort including assembly and initial testing of a Reverse Water-Gas Shift reactor (RWGSr) and initial testing of two gas separation membranes. The RWGSr was sized to reduce CO₂ produced by a crew of four to carbon monoxide as the first stage in a Series Bosch system. The gas separation membranes, necessary to recycle unreacted hydrogen and CO₂, were similarly sized. Additionally, we report results of preliminary experiments designed to determine the catalytic properties of Martian regolith simulant for the carbon formation step.

Nomenclature

B-CaTS	=	Bosch Catalyst Test Stand
BOP	=	balance of plant
CDEA	=	Carbon Dioxide Extraction Assembly
CM	=	crew member
LEO	=	low Earth orbit
MRS	=	Martian regolith simulant

¹ Aerospace Engineer, ECLSS Development Branch, ES62, AIAA Member.

² Aerospace Engineer, ECLSS Development Branch, ES62, AIAA Member.

³ Test Engineer, ECLSS Development Branch, ES62, AIAA Member.

⁴ Geologist, Technology Development and Transfer Office, ZP30, non-member.

⁵ NASA Intern, ECLSS Development Branch, Marshall Space Flight Center, Iowa State University, non-member.

⁶ NASA Intern, ECLSS Development Branch, Marshall Space Flight Center, Embry-Riddle Aeronautical University – Daytona Beach, non-member.

RWGS = Reverse Water-Gas Shift
 RWGSRA= Reverse Water-Gas Shift Reactor Assembly
 S-Bosch = Series-Bosch
 SmLPM = Standard milliLiters Per Minute

I. Introduction

THE Bosch Process is a combination of catalytically-enhanced reactions including the Reverse Water-Gas Shift (RWGS) reaction, the carbon monoxide (CO) hydrogenation reaction, and the Boudouard reaction, which collectively result in the Bosch Process as shown below.

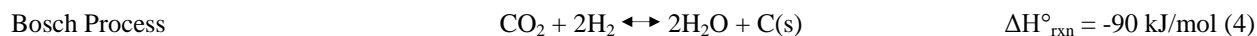
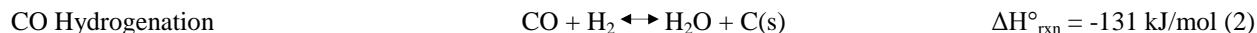
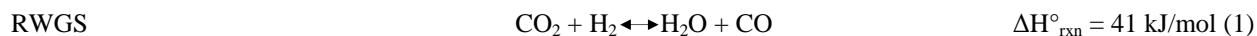

Reaction 1 initiates the process by reducing carbon dioxide (CO₂) to CO. Reactions 2 and 3 further reduce CO to form solid carbon. Water is produced at both steps through Reactions 1 and 2. This process has traditionally been investigated at NASA as a life support loop closure process for manned space flight missions. To create a closed-loop life support system based on the Bosch process, the water product is electrolyzed according to Reaction 5, thereby generating hydrogen (H₂) and oxygen (O₂).

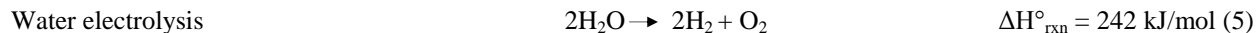

The H₂ is recycled back into the Bosch process, theoretically enabling greater than 100% O₂ recovery from metabolically produced CO₂. In all demonstration-scale systems operated to date, the reactants appear to penetrate the catalyst surface and form insoluble products, leading to the disintegration and dispersal of the catalyst. While this mechanism seems to enhance the kinetic properties of the catalyst due to increased active surface area, it also leaves the catalyst chemically dissolved in the product. This effectively makes the catalyst a short-lived, expendable component.

Although investigated for over five decades by NASA, technology based on the Bosch process has historically been plagued by process design and operation inefficiencies, difficulty handling the solid carbon product, and prohibitively large resupply requirements in the form of expendable pre-packaged catalyst cartridges. Prior to 2009, Bosch test systems involved two, identical reactors, operating in an alternating fashion (only one reactor operating at a time) in which Reactions 1-3 were catalyzed at 550-650°C and 15-30 psia (103-207 kPa). These systems are referred to as “single-reactor” systems because only one reactor can be carrying out the reaction at any given moment. Due to the exothermicity of equations 2 and 3, the rate of the carbon formation step was limited, resulting in an enlarged system to handle the high recycle rates necessary to achieve a four crew member (4-CM) CO₂ reduction rate. Additionally, undesirable carbon was observed in gas lines exiting the reactor as well as regenerative heat exchangers. Finally, the low density of the solid Bosch product has been another driver of large reactor volumes and high catalyst cartridge replacement frequency. A Bosch ground demonstration unit produced in the 1990’s achieved a catalyst cartridge life span of only about 19 days, despite a rather large reactor volume of approximately 50 L. Because of the additional launch cost of the replacement cartridges, Bosch systems have traded well below Sabatier technology for missions to low Earth orbit (LEO).¹

For long-term space missions beyond low Earth orbit, O₂ loop closure is of critical importance. While a Bosch-based technology has the potential to recover O₂ from both metabolic CO₂ and atmospheric CO₂ (for Mars missions), the limitations listed above must first be addressed. For this reason, the last several years of NASA-sponsored Bosch research have focused on system redesign and improvements in catalyst life span, regenerability, and catalytic activity.²⁻³ As mentioned before, for a single-reactor system, the optimum rate for the overall reaction is achieved by utilizing conditions which are somewhere between the ideal conditions for reaction 1 and the combined step of reactions 2 and 3. In order to overcome the rate limitations imposed by that compromise, NASA engineers are now investigating an innovative Bosch process design concept comprising a series-reactor system. The

Series-Bosch (S-Bosch) permits the independent optimization of the two steps in the process. The resulting improvement in overall reaction rate should ultimately reduce the total size of the system. Additionally, alternative catalysts have been explored to increase catalyst activity, increase the density of the carbon product, and influence the carbon formation mechanism(s) in an effort to maximize catalyst life. Despite extensive testing, no catalyst has yet been found to produce carbon at higher rates or with greater selectivity than the traditional iron fiber catalyst. Another approach to reducing Bosch catalyst resupply requirements has been proposed in which iron-rich *in situ* materials may be used as the carbon formation catalyst, thereby greatly reducing the catalyst resupply burden for missions with surface operations. Martian and lunar regolith is known to contain high concentrations of iron, making it a potential catalyst for both reaction steps. Use of regolith will involve launching enough catalyst to reach the desired surface, but *in situ* regolith may then be used as the catalyst for the duration of the surface mission as well as, perhaps, the return mission.

The S-Bosch approach includes separate reactors for the RWGS reaction and the carbon formation reactions as well as separation membranes necessary to enhance the recycle capabilities of the system. Following the completion of Aspen and COMSOL design studies at the beginning of 2012,⁴ fabrication and assembly of a partial 4-crew member (CM) S-Bosch system was initiated. Furthermore, initial catalyst performance testing of Martian regolith simulant (MRS) has been completed. This paper provides the specifics of both of these efforts.

II. Materials and Methods

Materials and methods for two efforts to advance a Bosch-based CO₂ reduction technology are reported here. The first describes materials required to assemble a partial S-Bosch reactor. The second describes the materials and methods for testing Martian regolith simulant.

A. Series-Bosch Materials

Based on the Aspen modeling previously reported⁴, four critical systems were identified for an S-Bosch system: an RWGS reactor, a hydrogen separation membrane, a carbon dioxide separation membrane, and a carbon formation reactor. Based on the results of testing reported in 2011⁵, Incofoam® nickel foam catalyst, shown in Figure 1, was selected as the catalyst for the RWGS reactor. COMSOL Multiphysics® simulations were used to select the internal dimensions of the RWGS reactor⁴. A mechanical design for the RWGS reactor was completed in 2012. Materials testing in the 1970's identified carbon deposition-resistant materials for the Bosch process.⁵ Based on those results, Inconel 625 was chosen as the base material for the RWGS reactor. To further increase the robustness of the reactor against undesirable carbon formation, the internal surfaces of the reactor were flash-coated with copper, which is highly inert to the deposition reactions. A spacer at the inlet of the reactor was designed to incorporate an insulating material previously shown to enhance flow distribution. Finally, the design included six thermocouple wells along the length of the catalyst bed in order to monitor the reactor internal temperature profile during testing.

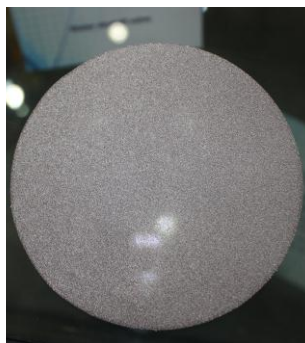

Figure 1. Incofoam® nickel foam catalyst cut for reactor packing.

For efficient gas recycling, two separation membranes were identified for the S-Bosch system. The Polaris and Proteus membranes were developed by Membrane Technology and Research, Inc. (MTR) with funding from the Department of Energy for use in scrubbing flue gas. The Proteus membrane, shown in Figure 2, was designed to separate H₂, while the Polaris membrane (not shown) was designed to separate CO₂. While MTR has performance data available for systems designed for a full-scale coal plant, no data has yet been collected for the smaller-scale systems designed and fabricated for S-Bosch testing.

The most challenging component of an S-Bosch system will ultimately prove to be the carbon formation reactor. At this time, no carbon formation reactor has been fabricated for use in the S-Bosch system. However, several concepts which would address the various challenges associated with this component have been proposed by commercial groups.



Figure 2. Proteus CO₂ removal membrane.

B. Martian Regolith Simulant Testing Materials and Methods

The Bosch Catalyst Test Stand (B-CaTS), described previously²⁻³, was used for all regolith simulant testing. JSC-Mars-1A MRS was purchased from Orbital Technologies. The material was sieved to obtain particles between 355 μ m and 1mm diameter. The chemical composition is shown in Figure 3.

For each test, 100mL of simulant was packed into a 4.57cm inner diameter quartz reactor tube. The material was separated into three sections of 20mL, 30mL, and 50mL (in that order when moving in the direction of gas flow) to facilitate observations of carbon formation gradients. Each section was packed on either side with discs of Fiberfrax® Durablanket® S insulation to provide physical support to the catalyst as well as assist in inlet flow distribution, as shown in Figure 4. After packing, the reactor tubes were installed into electric furnaces in the B-CaTS test stand and heated to the desired reaction temperature (650°C for RWGS testing and 550°C for carbon formation testing) at 14.5 psia (100 kPa) in a 100% nitrogen atmosphere. Prior to initiating the reaction, a gas stream of 50 mol% hydrogen and 50 mol% nitrogen was flowed through the bed at a total rate of 200 SmLPM for 90 minutes to reduce the catalyst surface. The reactor was then purged with nitrogen prior to the start of a test run.

Two tests were conducted on the regolith simulant including RWGS testing and Carbon Formation Testing. The

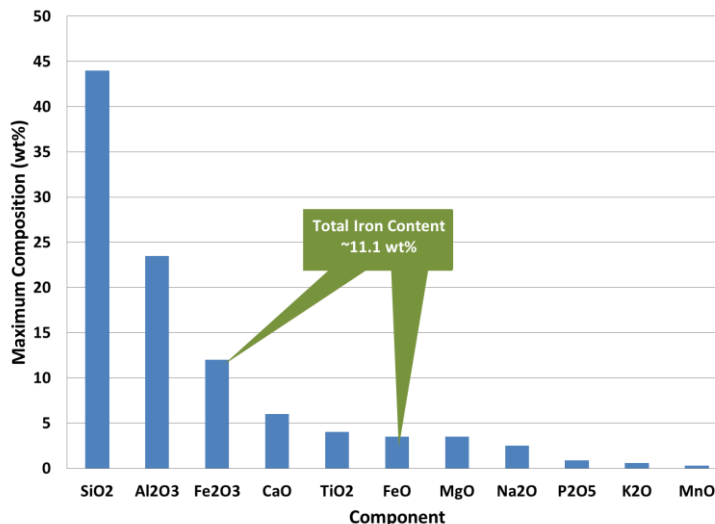

Figure 3. Major elemental composition of JSC-Mars-1A Martian regolith simulant.



Figure 4. Unreacted Martian regolith simulant-packed reactor tube.

RWGS reaction test was conducted at 650°C and 15.0 psia (103 kPa) with CO₂, H₂, and N₂ (inert carrier gas) fed through the tube at 100-, 100-, and 20-SmLPM, respectively. The Carbon Formation Reaction test was conducted at 550°C and 15.0 psia (103 kPa) with CO, H₂, and N₂ feeds at 200-, 200-, and 20-SmLPM, respectively. An Agilent 3000A micro-gas chromatograph with 2 channels (mol sieve packing with argon carrier and TCD detector, and Plot U packing with helium carrier and TCD detector) was used to analyze outlet gas composition.

III. Results and Discussion

Fabrication and assembly of a partial S-Bosch system was initiated in 2012 and is ongoing at the time of submission. Specific progress is detailed below. Additionally, initial testing was conducted on MRS to determine activity for both RWGS and carbon formation reactions. The results of this testing are detailed below.

A. S-Bosch Development

Per the system concept previously reported⁴, an S-Bosch system schematic was completed in late 2012. The system was separated into a total of nine sub-systems as listed below. System fabrication and assembly has not been completed, thus volume, weight, and performance characteristics of each sub-system have yet to be determined.

1. Gas Supply Assembly – includes the test stand gas feed bottles including carbon dioxide, hydrogen, and nitrogen.
2. Fluid Feed Control Assembly – includes mass flow controllers and valving to control gas feed streams.
3. Reverse Water-Gas Shift Reactor Assembly (RWGSRA) – includes a static mixer to mix the feed gases, the RWGS reactor, a regenerative heat exchanger, a back-pressure regulator, and all balance of plant (BOP) elements to monitor and control the assembly.
4. Fluid Recycle and Vent Assembly – includes a vacuum pump to recirculate process gases and maintain system sub-ambient pressures, provides a vent connection to exhaust built-up contaminants, and includes various BOP elements to monitor and control the assembly.
5. Water Separation Assembly – contains a condensing heat exchanger, water collection tank, and all BOP elements to monitor and control the assembly.
6. Carbon Dioxide Extraction Assembly (CDEA) – contains the Polaris Membrane and all BOP elements to monitor and control the assembly.
7. Hydrogen Extraction Assembly – contains the Proteus Membrane and all BOP elements to monitor and control the assembly.
8. Carbon Formation Reactor Assembly – will be designed at a later stage to accommodate various developmental reactors.
9. Fluid Analysis Assembly – contains a micro-Gas Chromatograph, dew point analyzer, and selector valves to facilitate monitoring of gas composition throughout the system. All other sub-assemblies are populated with sampling ports from which this assembly draws samples.

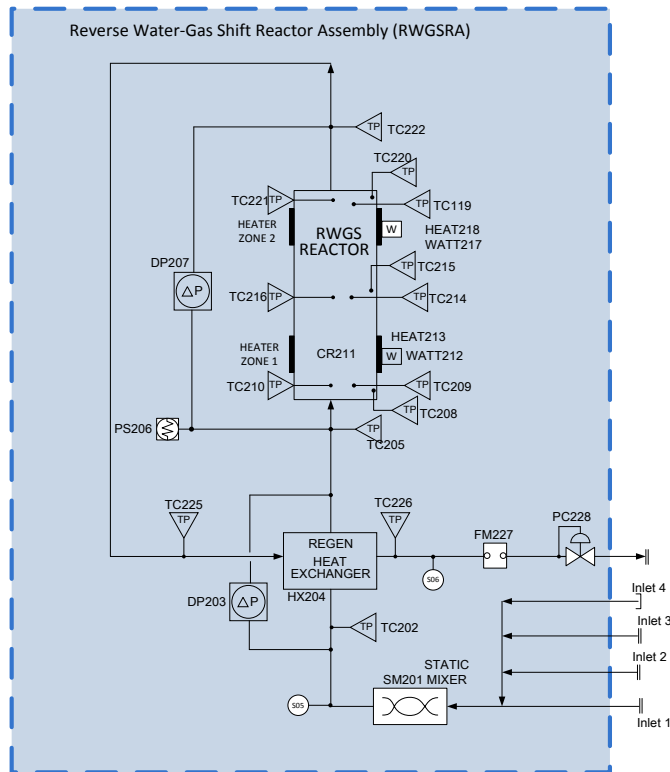

Figure 5. Reverse Water-Gas Shift Reactor Assembly as designed for integrated S-Bosch system.

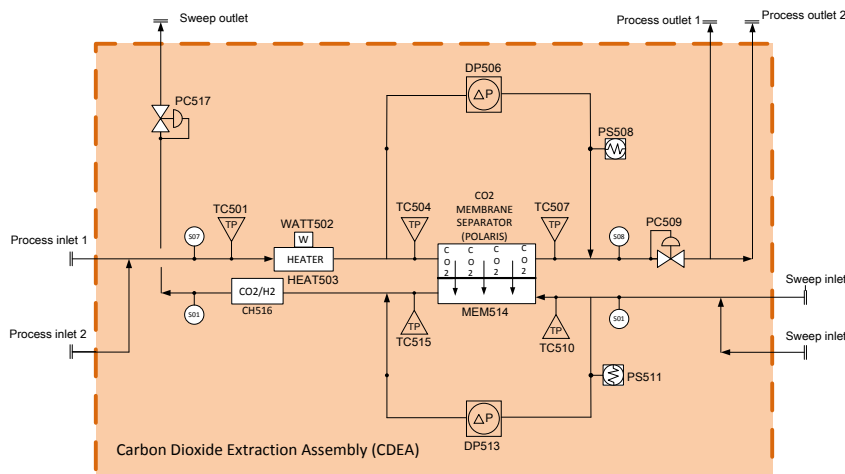

Figure 6. Carbon Dioxide Extraction Assembly as designed for an integrated S-Bosch system.

For the sake of brevity, only the RWGSRA and the CDEA are shown in Figure 5 and Figure 6, respectively. The Hydrogen Extraction Assembly is identical to the CDEA, with the exception of the membrane material itself.

Completion of the system design was followed by an RWGS reactor mechanical design. The internal dimensions of the reactor are 12.7 cm (5") diameter x 27.6 cm (10.875") length. However, the first 5.4 cm (2.125") and the final 3.0 cm (1.171") are packed with Fiberfrax® Durablanket® S quartz fiber batting and

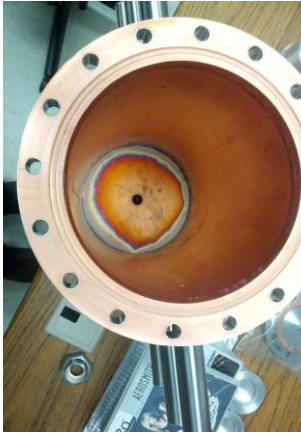

Figure 7. Damage to copper coating on RWGS reactor inlet due to welding.

baffled spacers in order to enhance flow distribution, leaving a catalyst bed length of only 19.25 cm (7.579”). Six thermocouple wells were welded onto the sides of the reactor in order to permit monitoring of the reactor internal temperature profile by thermocouple probes inserted through the thermowells. After fabrication, the internal surfaces of the RWGS reactor were flash-coated in copper. Prior to final assembly of the reactor, the inlet endcap was welded onto the reactor chamber. As can be seen in Figure 7, this welding process caused depletion of the copper coating near the weld. However, this is not expected to result in carbon formation for two reasons. First, the base material, Inconel 625, is known to be resistant to carbon formation. Second, the inlet of the RWGS reactor is expected to be



Figure 8. RWGS reactor as fabricated.

exposed to only trace quantities of carbon monoxide. Thus the activity of the carbon formation reaction should be minimal and not result in appreciable deposition. The final assembled RWGS reactor is shown in Figure 8.

B. Martian Regolith Simulant Testing

MRS was tested for performance as a catalyst for both steps in the Bosch process. The results of this testing are described below.

1. RWGS Reaction in Martian Regolith Simulant

As shown in Figure 9, the observed conversion rate for the RWGS reaction over MRS was initially 21%, and fell to 13% over 80 minutes of testing. These values are approximately 40-63% lower than those observed at the same conditions over Incofoam® nickel foam catalyst (previously reported at just under equilibrium conversion). However, the nickel foam is a purely catalytic material while the simulant has only a small percentage of catalytic iron. Therefore, the observed difference in performance is likely due largely to the lower density of available reaction sites on the simulant. Less favorable mass transport through and within the simulant compared to Incofoam® likely also contributes to the lower conversion. As such, an RWGS reactor design using regolith as the catalyst would require significantly more volume and mass than the current reactor using Incofoam®.

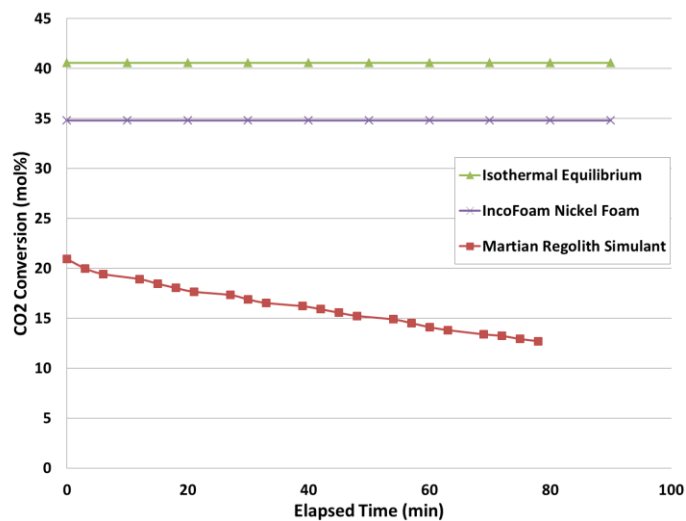

Figure 9. RWGS reaction on Martian and Lunar regolith simulant.

Although the simulant showed an initial conversion of over 20%, this was shown to steadily decrease over time. It was later determined that a heater at the reactor outlet was not functioning properly during this test. This probably caused water to condense and accumulate at the reactor outlet, thereby limiting or reversing the equilibrium reaction. It is believed that, when operated properly, this reaction would maintain steady performance as observed with the nickel foam, but at the lower 20% CO₂ conversion.

Based on these results, it does not seem advantageous within the context of exploration missions to use MRS as the catalyst for an RWGS reactor for two reasons. First, in order to provide the contact time necessary to reach equilibrium and accommodate variations in regolith iron content on the surface of Mars, a much larger reactor would be required than would be necessary using superior catalysts launched from Earth. Second, the catalyst is not

consumed in the RWGS reaction. Therefore, in an S-Bosch system, there is no resupply required for the RWGS. Thus, having a smaller, more efficient reactor would likely trade more favorably, despite the extra initial catalyst mass.

The fact that MRS is roughly 50% as effective as Incofoam® at catalyzing the RWGS reaction could still make it a valuable material for *in-situ* use in a single-reactor Bosch system.

2. Carbon Formation in Martian Regolith Simulant

Figure 10 shows images of the MRS before carbon formation testing and after 1hr, 4hrs, and 16hrs of carbon accumulation, respectively. As can be seen from the images, carbon formation is readily apparent after only an hour of operation. An attempt was made to quantify this carbon formation by weighing the reactors before and after carbon formation. However, a significant mass of oxygen was lost during the deoxidation procedure. In the case of the 1-hr tests, the reactor mass actually decreased. In future work, we hope to estimate the proportional loss of mass due to de-oxidation in order to allow quantification of the product masses reported here.

Previous testing with catalysts for the carbon formation reactions showed that at the temperatures of interest in this effort, the Boudouard reaction is dominant with respect to the CO hydrogenation reaction. For every mole of carbon produced via the Boudouard reaction, there is also a mole of CO₂ produced per Reaction 3. Because CO₂ is a

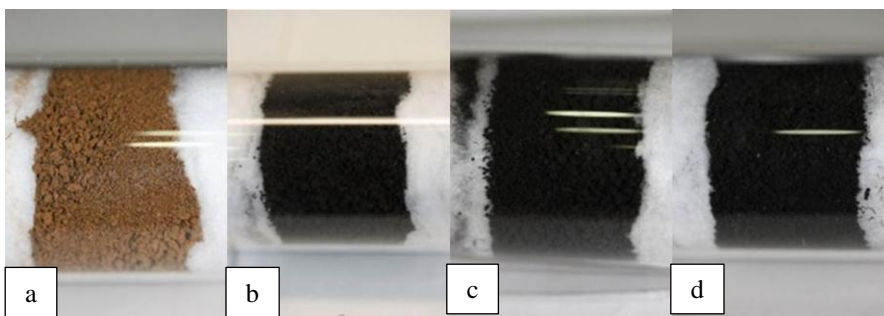

Figure 10. Martian regolith simulant. Pre-carbon formation (a) and after 1hr(b), 4hrs (c), and 16hrs(d) of carbon accumulation.

gaseous product that is easily measured using a gas chromatograph, the concentration of CO₂ in the reactor outlet can be used to compare rates of carbon formation. In previous testing, iron wool was evaluated as a catalyst under similar conditions to the current MRS testing. In particular, reactor temperature, reactor

pressure, and catalyst bed volume were identical. Total gas flow was slightly higher during the steel wool testing (540 SmLPM total for steel wool versus 420 SmLPM total for regolith simulant testing), but variations in this rate did not change the fractional CO₂ conversion. As can be seen in Figure 11, the carbon formation single-pass conversion efficiency for the simulant was significantly lower than the baseline iron wool. This is likely partially due to the much lower catalytic surface area available for reaction. This difference in performance translates to a larger reactor with more catalyst available for reaction if the regolith simulant is used rather than the baseline iron wool. In contrast to the RWGS reaction, the carbon formation reactions rapidly ultimately foul the catalyst material resulting in resupply requirements. For this step in an S-Bosch process, it may prove favorable to launch a larger reactor but less catalyst expendable materials (using MRS), than to launch a smaller reactor but more catalyst expendables (using iron wool), for certain mission profiles. However, a surface mission will provide accessibility to a virtually limitless supply of catalyst. Thus, the catalyst need not be as efficient as required when the catalyst must be provided from Earth. A trade study to examine this comparison would be necessary to determine the mission profiles for which a regolith catalyst-based approach would prove favorable.

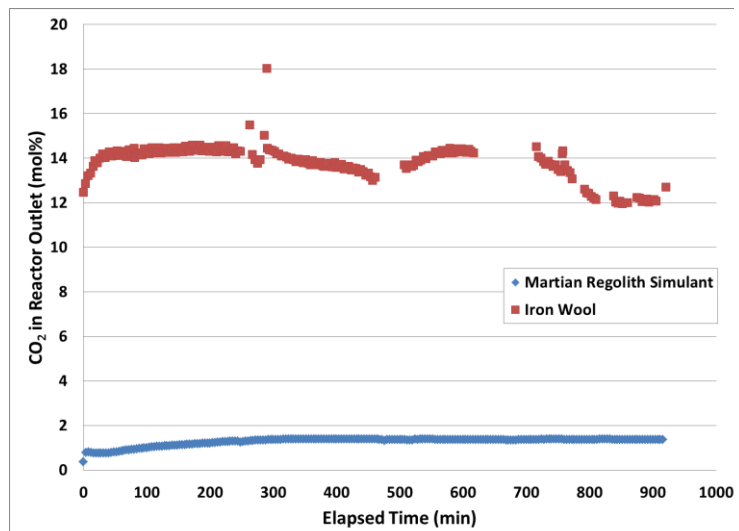

Figure 11. Comparison of carbon formation between Martian Regolith Simulant and Iron Wool.

IV. Future Work

Assembly of the S-Bosch system is ongoing. When completed, a series of three tests are planned. First, the RWGS reactor will be tested as a stand-alone unit in order to map the conversions as functions of temperature, pressure, flow rates, and inlet composition. Second, the membranes will be tested independently to determine absolute permeability of the desired gases in addition to the non-selective permeability of other gases. Finally, the RWGS reactor and the membranes will be integrated and tested together to observe recycle performance of the partial system. Because the currently designed S-Bosch does not include a well-defined carbon formation reactor, efforts will be taken to pursue commercial contributions in this area.

Based on the initial carbon formation results for the MRS, an effort will be undertaken to approximate the necessary reactor size to realize a regolith-catalyzed carbon formation reactor. This size (mass, volume, power) will be included in a trade study comparing the penalties of a larger reactor versus catalyst resupply.

Acknowledgments

The authors would like to acknowledge NASA's Office of the Chief Technologist Next Generation Life Support Project, MSFC's Technology Transfer group, the President's Early Career Award for Scientists and Engineers, and MSFC's Technical Innovation Grant for funding this work. Additional thanks go to Dr. Jim Alleman at Iowa State University and John Thomas and Dave Long at NASA MSFC.

References

¹Carrasquillo, R.L., Carter, D.L., Holder, D.W. Jr., McGriff, C.F., Ogle, K.Y., "Space Station *Freedom* Environmental Control and Life Support System Regenerative Subsystem Selection," NASA Technical Memorandum 4340, 1992.

²Abney, M.B., Mansell, J.M., "The Bosch Process - Performance of a Developmental Reactor and Experimental Evaluation of Alternative Catalysts," *40th Annual Conference on Environmental Systems*, AIAA Technical Paper, AIAA-2010-6272, Barcelona, Spain, July 11-15, 2010.

³Abney, M.B., Mansell, J.M., "Evaluation of Bosch-Based Systems Using Non-Traditional Catalysts at Reduced Temperatures," *AIAA International Conference on Environmental Systems*, AIAA-2011-5059, Portland, OR, July 17-21, 2011.

⁴Abney, M. B., Evans, C., Mansell, M., and Swickrath, M., "Series Bosch System Development," *AIAA International Conference on Environmental Systems*, AIAA 2012-3554, AIAA, San Diego, CA, 2012.

⁵Holmes, R.F., Keller, E.E., King, C.D., "A Carbon Dioxide Reduction Unit Using Bosch Reaction and Expendable Catalyst Cartridges," *NASA CR-1682*, General Dynamics Corporation, Convair Division, 1970.