

National Aeronautics and Space Administration



Unmanned Aircraft Systems (UAS) Integration in the National Airspace System (NAS) Project

Presented by: Mr. John Walker on behalf of Mr. Chuck Johnson
Manager, UAS Integration in the NAS Project

ICAO Regional Unmanned Aircraft Seminar
Lima, Peru April 18-20, 2012

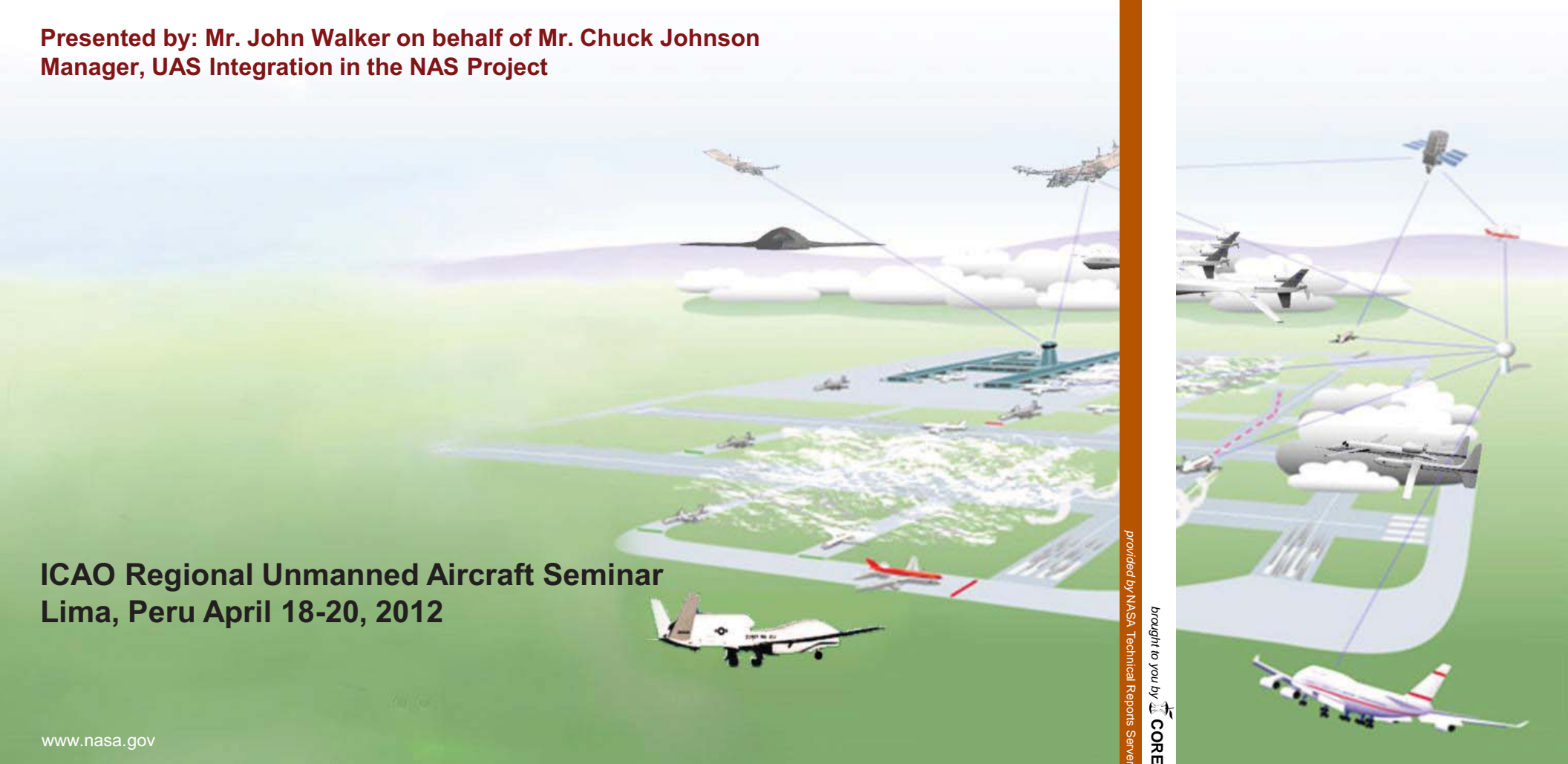

Problem Statement

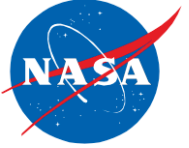

- There is an increasing need to fly UAS in the NAS to perform missions of vital importance to National Security and Defense, Emergency Management, Science
- There is also an emerging need to enable Commercial Applications
- UAS are unable to routinely access the NAS today due to numerous barriers including, but not limited to, a lack of:
 - Validated technologies and procedures which ensure UAS can maintain safe separation from other aircraft
 - Secure and scalable command and control communications systems for UAS
 - Robust and certified pilot/aircraft interfaces for Ground Control Stations (GCS)
 - Standardized safety and certification regulations applicable to UAS
- The technologies, procedures, and regulations to enable seamless operation and integration of UAS in the NAS need to be developed, validated, and employed by the FAA through rulemaking and policy development

How the Project Focus was Determined



- Used stakeholder inputs to confirm project focus (since 2009)
 - Vetted with UAS Executive Committee (ExCom), FAA Technical Center, FAA Unmanned Aircraft Program Office (UAPO), RTCA Special Committee 203 (SC-203), and industry
- Leveraged knowledge gained and lessons learned from previous NASA and National work (small sample)
 - Long history of flying UAS (since 1968)
 - Access 5 Project (2003-2006)
 - RTCA Operational Services and Environment Definition (OSED) for UAS (dated April 2010)
- Ensured work aligned with NASA skills and expertise
- Synergistic work (not unnecessarily duplicative with other activities)
- Timeframe for Impact – 2015-2025
- Inputs from Meeting of Experts (MoE) held on August 5, 2010
 - Led to focus on civil access and elimination of Sense And Avoid (SAA) sensors and algorithms from work
- Meeting with FAA and RTCA held on November 29-December 1, 2011
 - Led to expansion of work to include defining SAA system and interoperability requirements
 - Led to expansion of work to include certification methodology for type design certificate

UAS Integration in the NAS



Need Statement

The Unmanned Aircraft Systems (UAS) Community needs routine access to global airspace for all classes of UAS

Project Goal

Utilize integrated system level tests in a relevant environment to eliminate or reduce technical barriers related to the safety and operational challenges of integrating UAS into the NAS

Technology Development Areas

Separation Assurance-Sense and Avoid Interoperability (SSI), Human Systems Integration (HSI), Communications, Certification, Integrated Test & Evaluation

Key Stakeholders

UAS ExCom, FAA, JPDO/NextGen, DoD, SC-203 and other Standards/Regulatory Organizations

Time-frame for Impact 2015 to 2025

Two-Step Approach

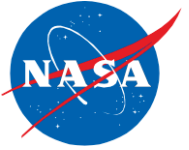

- The project goal will be accomplished through a two-step approach based on development of system-level integration of key concepts, technologies and/or procedures, and demonstrations of integrated capabilities in an operationally relevant environment.
- **Initial Activities (first 12-24 months)**
 - Conduct initial modeling, simulation, and flight testing
 - Complete early subproject-focused deliverables (spectrum requirements, comparative analysis of certification methodologies, etc.)
 - Use deliverables from early investment activities to help the FAA define a national vision and strategy for civil UAS access to the NAS
 - **Validate the key technical elements identified by this project**
- **Integrated Activities (last 36-48 months)**
 - Conduct systems-level, integrated testing of concepts and/or capabilities that address barriers to routine access to the NAS.
 - Provide regulators with a methodology for developing airworthiness requirements for UAS, and data to support development of certification standards and regulatory guidance
 - **Develop a body of evidence to support the safe integration of UAS into the NAS**

Project Phasing Plan

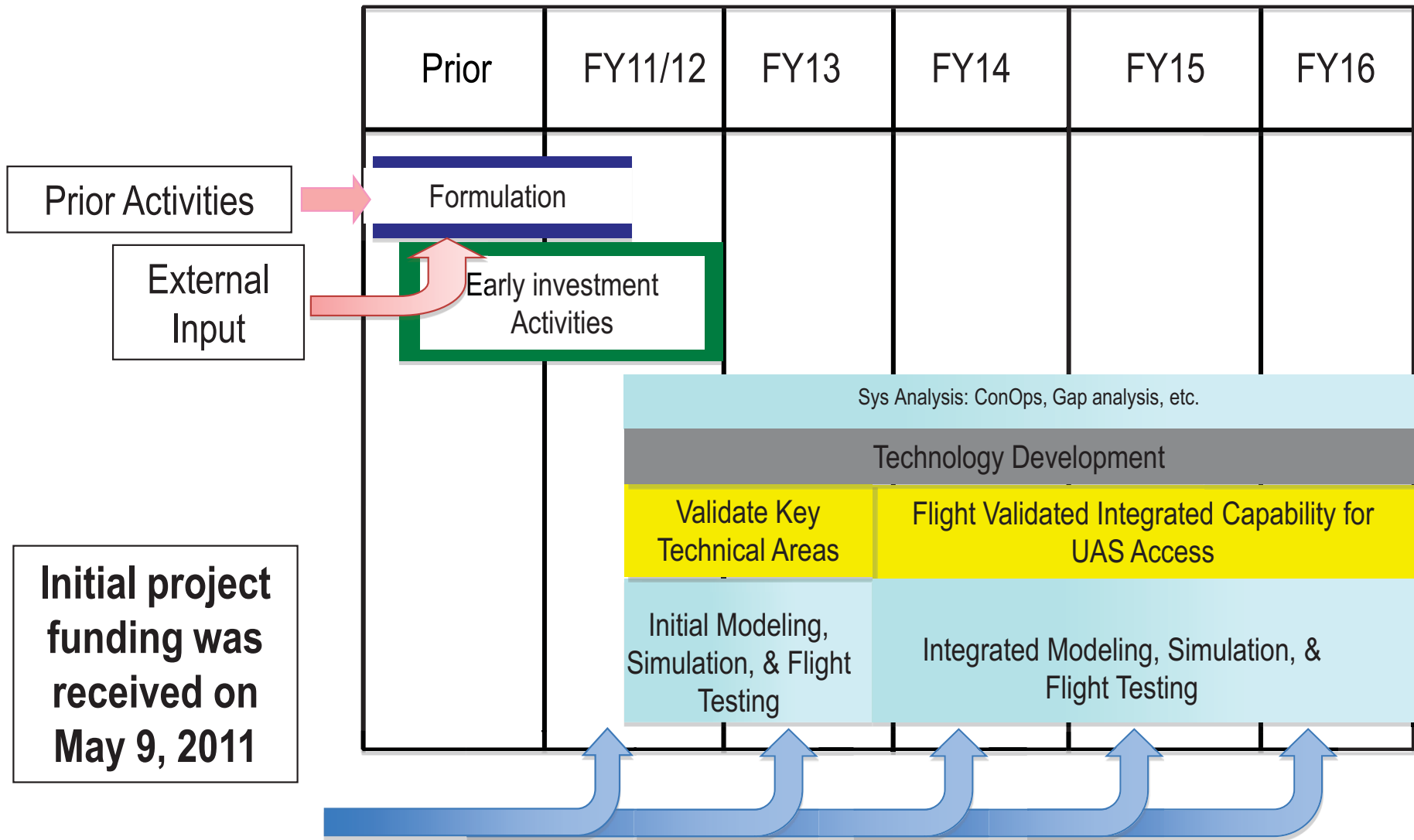

Technical input from Project technical elements, NRAs, Industry, Academia, Other Government Agencies

Separation Assurance – Sense and Avoid Interoperability (SSI)



- **The SSI subproject will address barriers to on-demand UAS operations in non-segregated airspace that are due to:**
 - The uncertainty surrounding the ability to interoperate in ATC environments and maintain safe separation from other aircraft in the absence of an on-board pilot.
 - The lack of validated requirements for Sense And Avoid (SAA) systems and their interoperability with separation assurance functions.
 - The lack of data supporting the safety of UAS operations in non-segregated airspace.

- **The SSI technical challenge will be met through two primary objectives:**
 1. Assess the effects of UAS performance characteristics, communications latencies and changes to separation roles and responsibilities on the airspace
 - Assess the applicability to UAS and the performance of NASA NextGen separation assurance concepts in flight tests with realistic latencies and trajectory uncertainty
 - Provide an assessment of how NextGen separation assurance systems with different functional allocations perform for UAS in mixed operations with manned aircraft

 2. Assess the interoperability of UAS sense-and-avoid systems with the ATC environment
 - Determine the performance expectations (requirements) for UAS equipped with SAA systems in order to validate FAA defined SAA requirements
 - Determine the effects (capacity, workload, efficiency) of UAS Separation Assurance (SA) and SAA interoperability on the ATC environment

Sense and Avoid (SAA) System

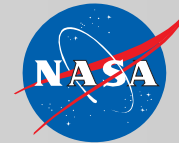

The SAA system includes both Self Separation and Collision Avoidance functions.

The Collision Volume Threshold is a fixed distance based boundary

The Collision Avoidance Threshold is a variable boundary that depends on time, distance, maneuverability, and other parameters.

The Self Separation Threshold (well clear) is a variable boundary that depends on time, distance, maneuverability, and other parameters.

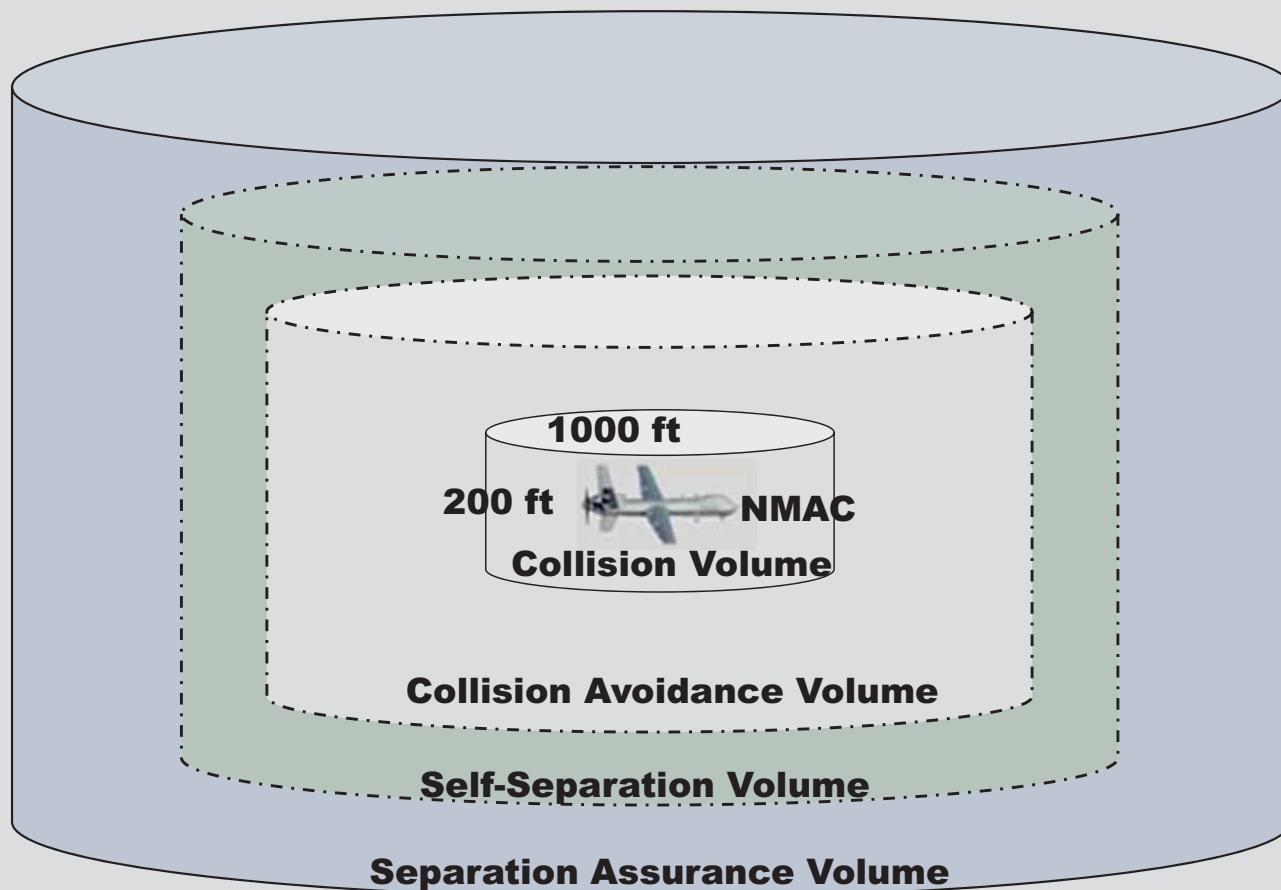

SAA/SA Interoperability

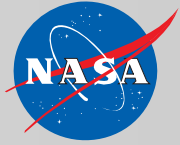

Collision Avoidance – SAA action to prevent an intruder from penetrating the collision volume when all other modes of separation fail.

Self Separation – SAA maneuver by the UAS pilot within a sufficient timeframe to prevent activation of CA while conforming to accepted air traffic separation standards.

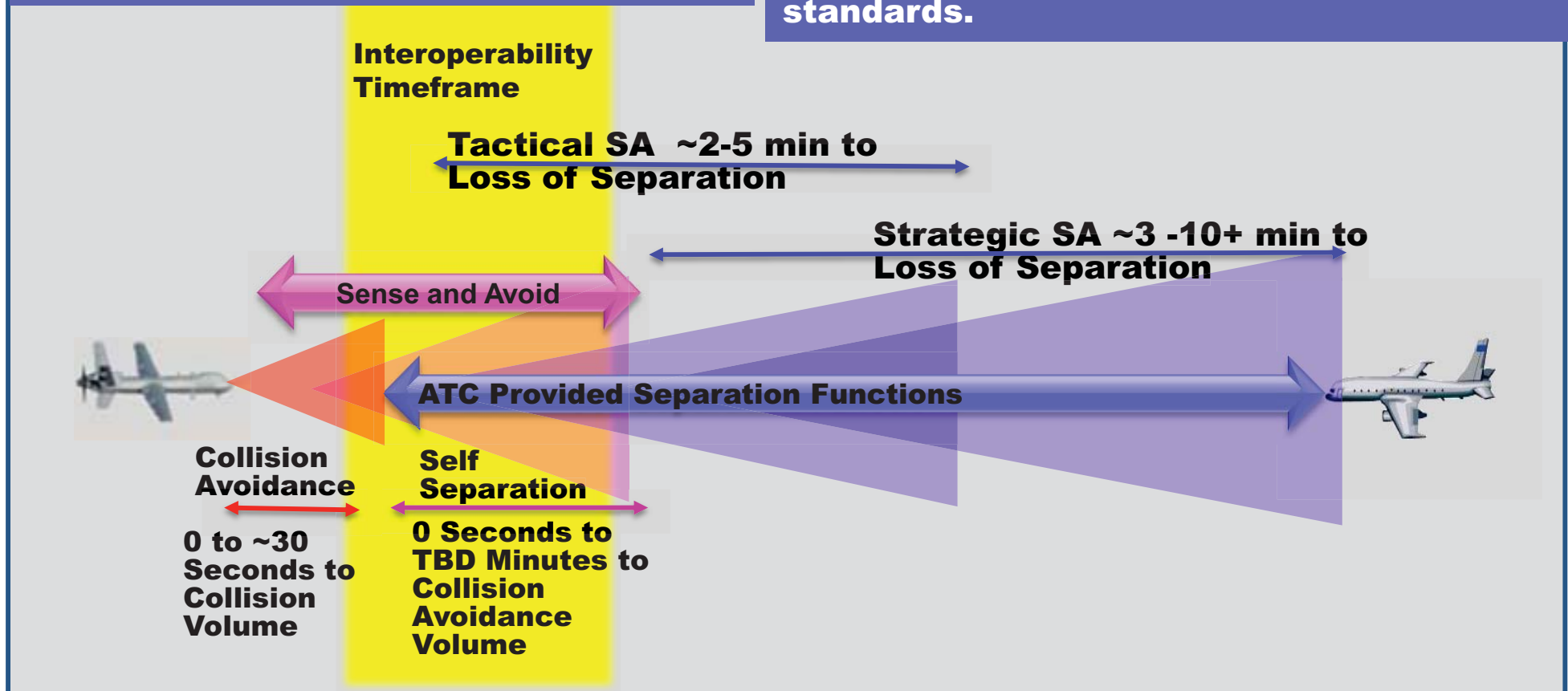

**Notional depiction of overlapping detection look-ahead times for different SA and SAA functions (not to scale).
Look-ahead times vary with different algorithms.**

Human Systems Integration

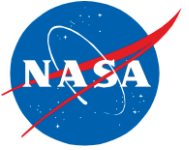

- **The HSI subproject will seek to address barriers regarding lack of standards and guidelines with respect to UAS display/information as well as lack of Ground Control Station (GCS) design requirements to operate in the NAS.**
- **Objectives**

The HSI technical challenge will be met through two primary objectives:

 1. Develop a research test-bed and database to provide data and proof of concept for GCS operations in the NAS.
 2. Coordinate with standards organizations to develop human factors guidelines for GCS operation in the NAS.

HSI Subproject

Efficiently manage contingency operations w/o disruption of the NAS



Seamlessly interact with SSI

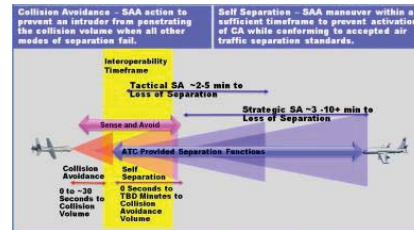

Coordinate with ATC - respond w/o increase to ATC workload



Research test-bed and database to provide data and proof of concept for GCS operations in the NAS

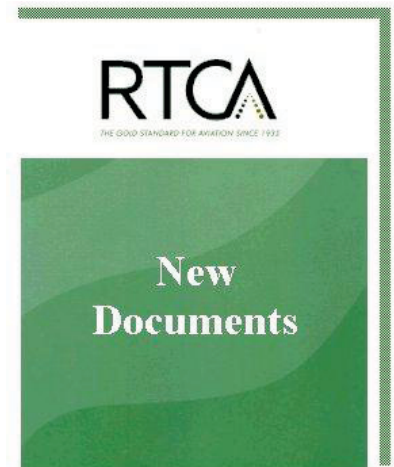

Human factors guidelines for GCS operation in the NAS



Ensure operator knowledge of complex airspace and rules



Standard aeronautical database for compatibility



Traffic information for situation awareness and separation (NextGen)



Communications

- **The Communications subproject will seek to address barriers regarding lack of frequency spectrum and data links for civil UAS control communication.**
- **Objectives**

The Communication subproject technical challenge will be met through 4 primary objectives:

 1. Develop data and rationale to obtain appropriate frequency spectrum allocations to enable the safe and efficient operation of UAS in the NAS.
 2. Develop and validate candidate UAS control and non payload (CNPC) system prototype, which complies with proposed international/national regulations, standards, and practices. (The prototype CNPC radios are being developed under a cost-sharing cooperative agreement with Rockwell Collins.)
 3. Perform analysis and propose CNPC security recommendations for public and civil UAS operations.
 4. Perform analysis to support recommendations for integration of CNPC and ATC communications to ensure safe and efficient operation of UAS in the NAS.



Civil UAS Communication Notional Architecture

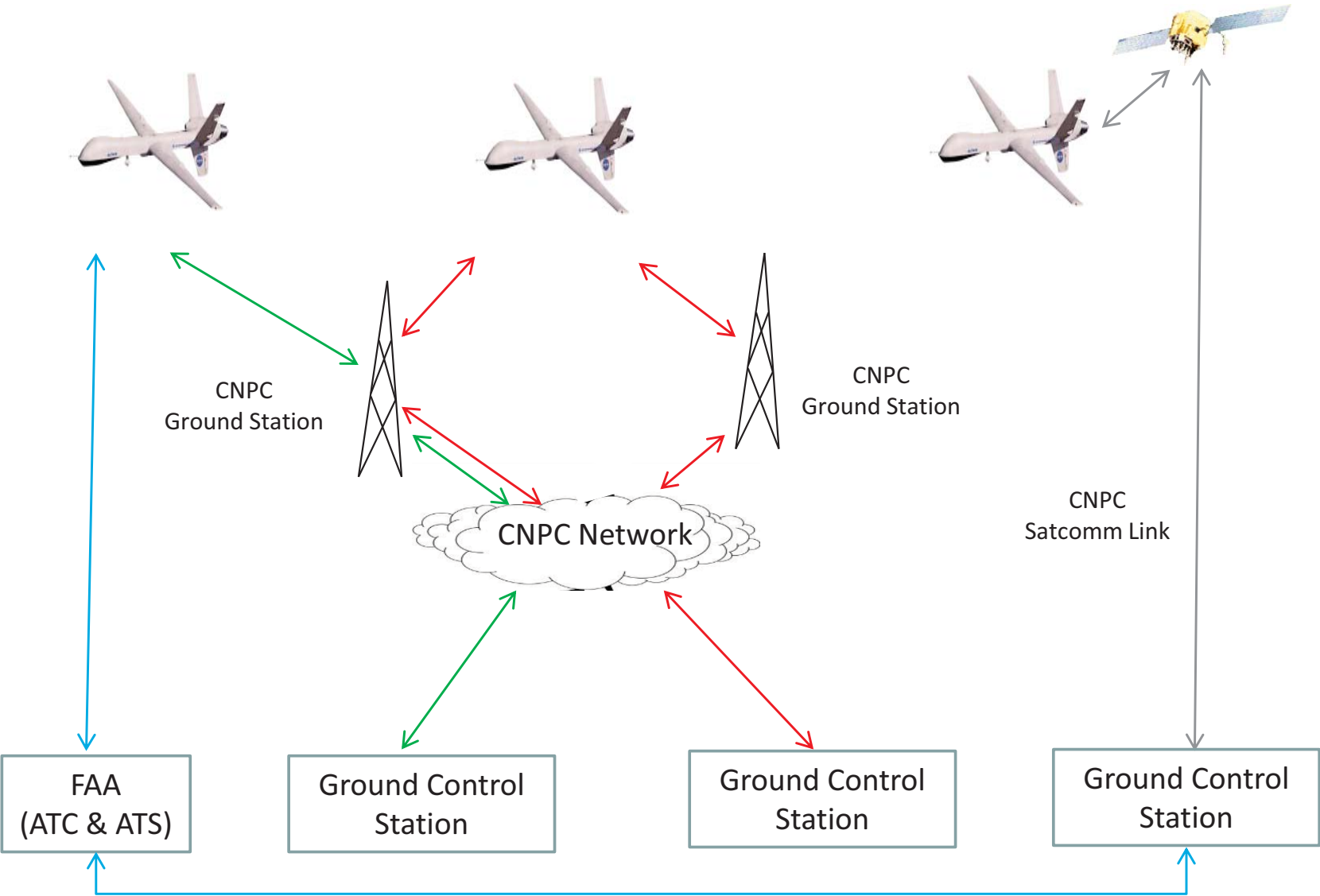

Possible Future ATS and ATC Ground Connectivity

Communication Subproject Focus

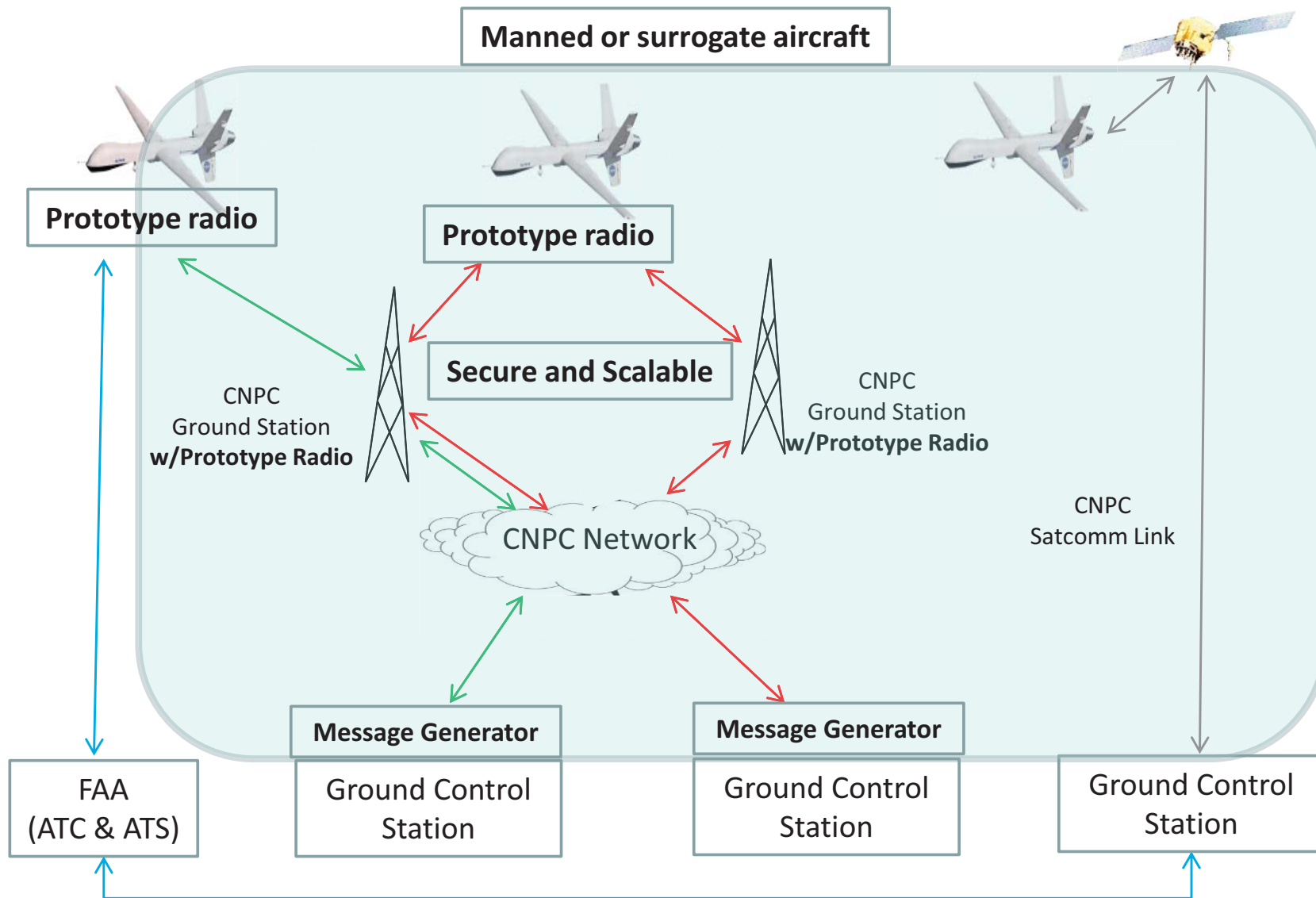

Possible Future ATS and ATC Ground Connectivity

Certification



- **The Certification subproject seeks to reduce two related barriers regarding certification:**
 1. The lack of airworthiness requirements specific to the full range of UAS, or for their avionics systems or other components
 2. The lack of safety-related data available to support decision making for defining airworthiness requirements
- **Objectives**

The Certification subproject technical challenge will be met through two primary objectives:

 1. Methodology for classification of UAS and determination of airworthiness standards for avionics aspects of UAS.
 2. Hazard and risk related data to support development of regulation.
 3. Methodology for developing a type design certificate for civil UAS (not yet approved)

Certification Subproject: Regulatory Framework



Title 14 Code of Federal Regulations
a.k.a. *Federal Aviation Regulations (FARs)*



No person may operate an aircraft unless it is in an **airworthy condition** (FAR 91.7a)

- conforms to its type design and is in a condition for safe operation (FAR 3.3)
- What is the best approach to prescribing airworthiness requirements on UAS, especially their avionics? By categories?
- What does existing data from UAS failures/incidents/accidents tell us to help us know what regulation is needed?
- What would the certification process look like for a UAS? By example...

Integrated Test & Evaluation



- **The IT&E Subproject will reduce barriers associated with SA, HSI, and Communications by creating an appropriate test environment, integrating the technical research to probe and evaluate the concepts, and coordinating and prioritizing facility and aircraft schedules.**

- **Objectives**

The IT&E technical challenge will be met through two primary objectives:

1. Define and develop an adaptable and scalable infrastructure that will create operationally relevant environments incorporating the concepts and technologies to be evaluated by the technology subprojects
2. Employ systems level integrated simulations and flight tests to validate models, assess system interactions, and determine the effectiveness of the concepts and technologies at reducing the technical barriers associated with routine UAS access into the NAS

Notional LVC Distributed Environment



- Core connectivity between Dryden and Ames
- Distributed environment provides the opportunity to utilize unique assets from geographically dispersed facilities
- Virtual simulations inject human interactions into a central role by exercising the decision making process and communications
- Virtual traffic generated to present complex conflict scenarios without imposing collision risks to “live” aircraft
- Complex airspace can be evaluated while the “live” aircraft fly in “safe” restricted airspace

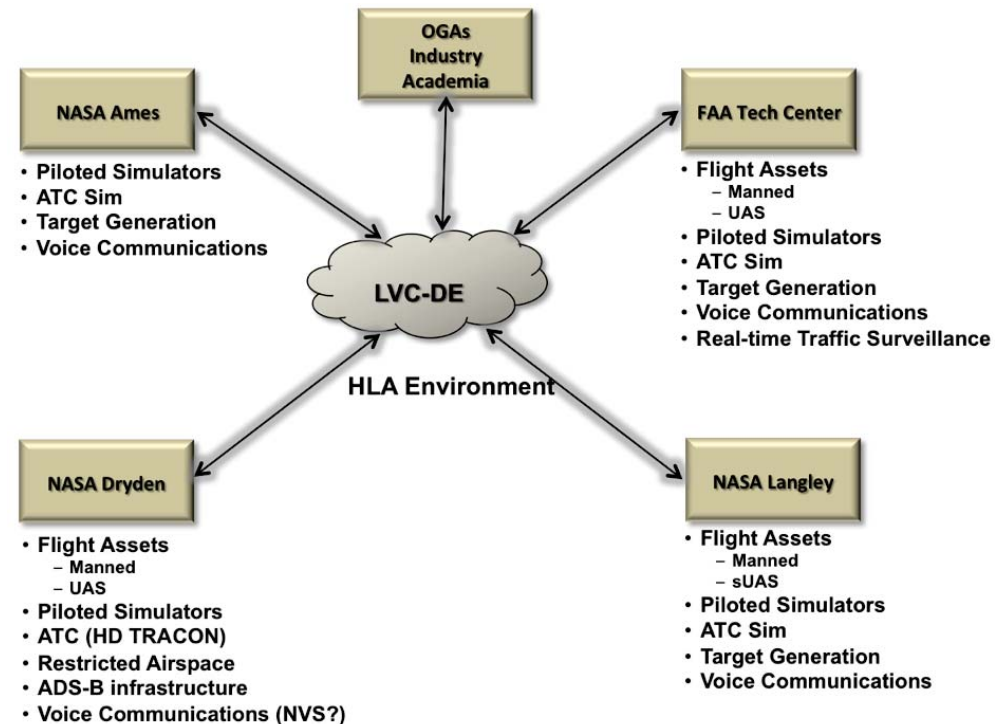

Partnerships and Collaborations

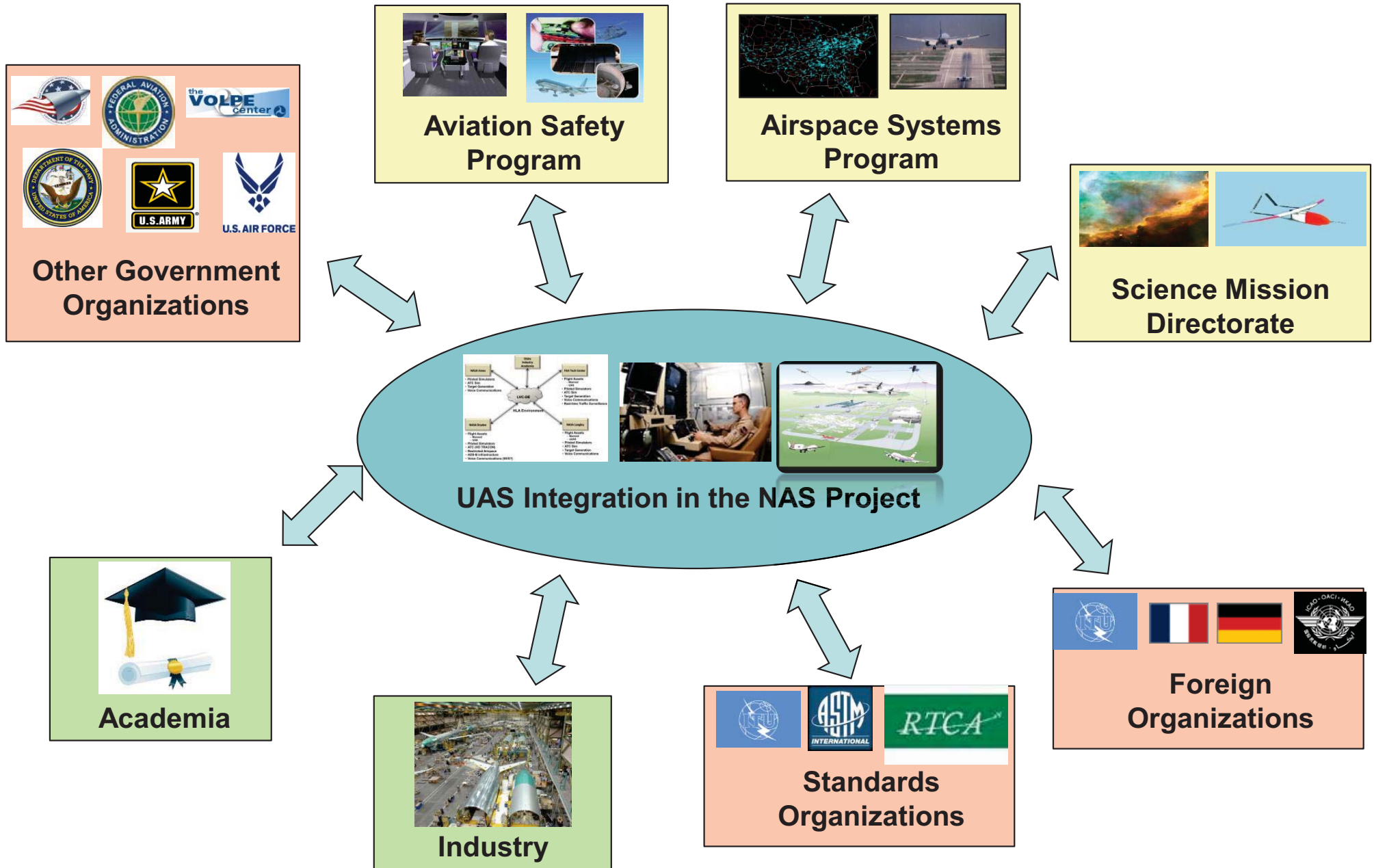

Summary

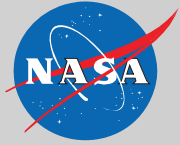

The Goal of the Project is to utilize integrated system level tests in a relevant environment to eliminate or reduce technical barriers related to the safety and operational challenges of integrating UAS into the NAS

- **General**
 - The project aligns with NASA Strategic Goals and National Aeronautics R&D Plan
 - The project has already begun delivering products benefiting key stakeholders
- **Technical Plan**
 - The technical elements of the project have been vetted with stakeholders
 - The project will employ a two-step approach. We will validate the key technical elements identified by the project during the first two years and then develop a body of evidence to support the safe integration of UAS into the NAS during the remainder of the project.
- **Partnership Plan**
 - Key stakeholders have been heavily involved in the planning of this project and will continue to be during project execution