

Subsonic Transonic Applied Refinements By Using Key Strategies - STARBUKS In the NASA Langley Research Center National Transonic Facility

Roman W. Paryz¹

NASA Langley Research Center, Hampton, VA 23681

Abstract

Several upgrade projects have been completed at the NASA Langley Research Center National Transonic Facility over the last 1.5 years in an effort defined as STARBUKS - Subsonic Transonic Applied Refinements By Using Key Strategies. This multi-year effort was undertaken to improve NTF's overall capabilities by addressing Accuracy and Validation, Productivity, and Reliability areas at the NTF. This presentation will give a brief synopsis of each of these efforts.

Nomenclature

A/D	=	Analog / Digital	lpm	=	Liters per minute
α	=	Alpha	LPR	=	Langley Procedure
AoA	=	Angle of Attack	m, m ²	=	Meters, Square meters
ARC	=	Ames Research Center	mm	=	Millimeter
ATS	=	Automatic Test Sequencer	MMS	=	Mach Measurement System
bar	=	100KPa	M	=	Mach, million
β	=	Beta	MW	=	Megawatt
Measurement System		BLAMS = Balance Limit Alarm	NASA	=	National Aeronautics & Space Administration
°C	=	Degrees Celsius	N ₂	=	Gaseous Nitrogen
CD	=	Coefficient of Drag	NFMTC	=	National Force Measurement Technology Center
cm	=	Centimeter	NTF	=	National Transonic Facility
CRM	=	Common Research Model	ϕ	=	Phi
DSP	=	Digital Signal Processor	PRT	=	Platinum Resistance Thermometers
°F	=	Degrees Fahrenheit	PSF, psf	=	pounds per square foot
FAS	=	Facility Automation System	PSI, psi	=	pounds per square inch
FRS	=	Flow Reference System	Psia, Psig	=	Pounds per square inch absolute, gage
ft, ft ²	=	feet, square feet	Psia, Psid	=	Pounds per square inch absolute, differential
Hp	=	Horsepower	Q, q	=	Dynamic pressure (psf)
IGV	=	Inlet Guide Vanes	RMS	=	Root Mean Square
in, in ²	=	Inch, Square inches	ROME	=	Research Operations Maintenance Engineering
K	=	thousand	RPM	=	Revolutions per Minute
Kg	=	Kilogram	RTD	=	Resistance Temperature Device
KPa, Pa	=	Kilo Pascal, Pascal	s, sec	=	second(s)
KW	=	Kilowatt	SMSS	=	Sidewall Model Support System
LaRC	=	Langley Research Center	SQC	=	Statistical Quality Control
Lbs	=	pounds	θ	=	Theta
lbs-in	=	pounds-inch	UOH	=	User Occupancy Hours
lbs/sec	=	pounds per second	VG	=	Vortex Generator (s)
LN ₂	=	Liquid Nitrogen			

¹ Facility Manager, National Transonic Facility, Facilities & Laboratory Operations Group, Research Directorate, AIAA Associate Fellow

I. Introduction

Throughout the years, the NTF along with customer feedback has identified areas for improvements that become necessary as a facility matures. At a very high level, these improvements fall into three broad areas / needs that can be categorized as follows:

- High Accuracy / Validated Data – A facility that can produce results that can be trusted
- Increased Productivity – Being able to complete required testing in a timely manner
- Dependable Reliability – A facility that can keep working without interruption

The Subsonic Transonic Applied Refinements By Using Key Strategies (STARBUKS) effort addresses these areas for improvement in a concentrated, multi-year effort to improve NTF’s overall capabilities. This effort can be broken down into two major segments. The first segment covers the physical maintenance / upgrades that were performed and are summarized in the green blocks in Figure 1. These physical changes were then verified / validated in four separate test programs summarized in the blue blocks of Figure 1.

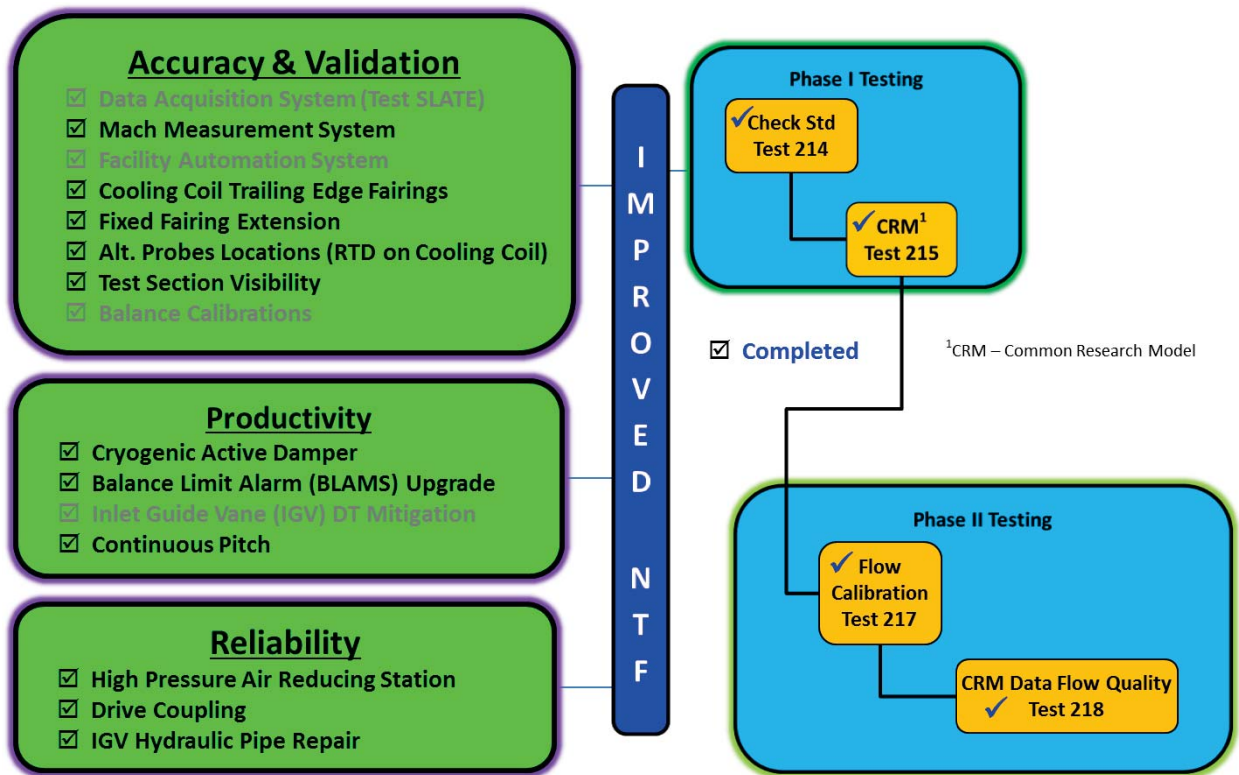

Figure 1. STARBUKS Summary

This paper will briefly discuss each of the items above except for those items that have been “greyed out” These items have been previously covered in References 1, 2, and 3.

II. Facility Description

The National Transonic Facility (NTF) is a fan-driven, closed-circuit, continuous-flow cryogenic pressurized wind tunnel that became operational in 1984 (Figure 2). The facility has the capability to adjust test conditions to match model size and has independent control of total temperature, pressure, and fan speed to allow isolation and study of pure compressibility (Mach) effects, viscous (Reynolds number) effects, and aero-elastic (dynamic pressure) effects. Combinations of these

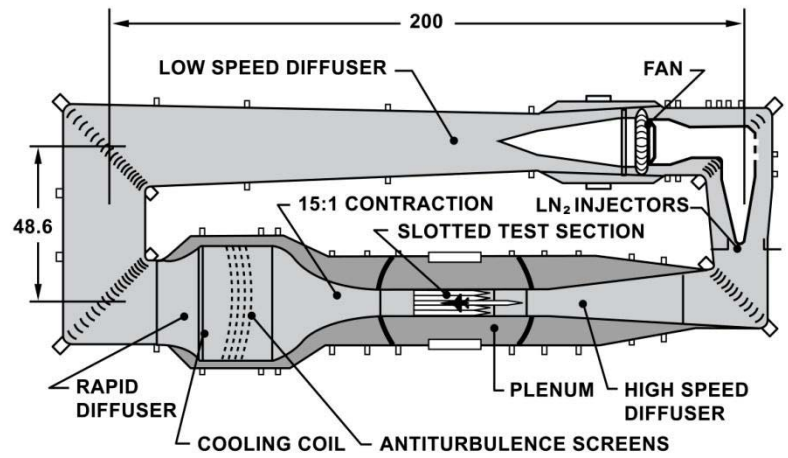

Figure 2. NTF Circuit Schematic

test parameters can yield Reynolds numbers from 2 to 145 million per foot (6.6 to 475.7 million per meter) (Figure 3). The test section is approximately 8.2 feet (2.5 meter) by 8.2 feet (2.5 meter) and 25 feet (7.6 meter) long with a cross sectional area of 67.2 ft² (6.2 m²). The test section has six slots in the ceiling, six slots in the floor, 14 re-entry flaps in the top and bottom walls to prevent the flow from choking the tunnel at near-sonic conditions, and a 6% openness ratio based on the wall surface area (wall divergence set at zero). See [Reference 2](#). NTF can be operated using either air or nitrogen as the test medium. During air operations temperature is controlled by a water-fed heat exchanger located in the settling chamber. During nitrogen operations the temperature is controlled by evaporating liquid nitrogen (LN2) which is dispersed into the tunnel circuit just upstream of the fan through 296 nozzles in 12 bundles at a maximum rate 1,100 lbs/sec (164 gallons/sec; 36K liters/sec). 430 tons of LN2 are produced on site per day and stored in two tanks with a total capacity of 3,800 tons (1.15M gallons; 4.4M liters). These two modes provide the ability to operate the tunnel between -250°F (-157°C) and +150°F (+65°C). Thermal insulation that resides inside the pressure shell minimizes energy consumption. Pressure is controlled by two large vent valves connected to the tunnel circuit between turns #3 and #4. The facility can operate from 14.7 psia (101.4KPa) to 133 psia (917.0 KPa) (1 to 9 atmospheres; 1.01 to 9.2 bar) in either medium. The tunnel drive system is powered by a variable speed motor that has adjustable maximum torque or power output that peaks at 360 RPM. At 360 RPM the maximum power is 135,000 Hp (101 MW) and that maximum power level is maintained up to 600 RPM. The compressor consists of a fixed pitch, single stage, 25-bladed, 20-foot (6.1m) fan with variable inlet guide vanes. For fine Mach number control, inlet guide vanes are varied to achieve the required compression ratio to maintain the desired Mach number. Temperature can be maintained within $\pm 0.3^\circ\text{F}$ (0.17°C) for N2 operations or $\pm 1^\circ\text{F}$ (0.56°C) for air operations; Pressure ± 0.07 psi (482 Pa); Mach number ± 0.0005 or better.

The NTF supports testing of stability and control, cruise performance, stall buffet onset, and configuration aerodynamics. The full-span model support system is a circular arc sector that provides an angle-of-attack range of -11.5° to 19.0° at a rate of up to 4° per second. The strut incorporates a roll drive with a range of $\pm 180^{\circ}$ which, in conjunction with the pitch of the strut, is able to provide pitch and yaw data. The normal force load capacity of the strut is 27,000 lbs (120,102 N). Several sting and strut combinations are available for testing of aerodynamic models. The NTF can accommodate various types of internal 6-component strain gage balances. Onboard angle-of-attack accelerometers are available that include thermal conditioning systems for cryogenic operation.

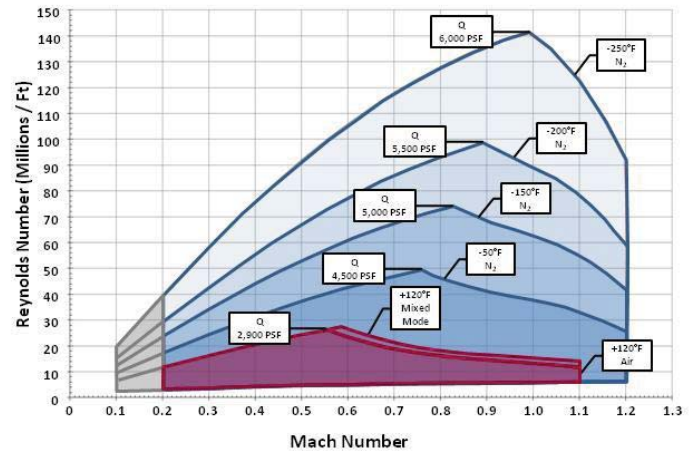

Figure 3. NTF Operating Map

The NTF can also conduct semi-span model investigations using the Sidewall Model Support System (SMSS). The SMSS is installed in the test section wall with the model mounted on the test section horizontal centerline. The SMSS has a $\pm 35^{\circ}$ pitch capability and can accommodate external 5-component strain gage balances up to 27,000 lbs (120,102 N) of normal force. The model is attached via adaptive hardware to the balance, which is installed behind the test section wall within an insulated and heated enclosure. The SMSS can also accommodate a dual channel, high pressure air system to support propulsion airframe integration studies, circulation control high-lift concepts, powered lift, and cruise separation flow control.

III. Physical Maintenance & Upgrade Projects

A. Accuracy & Validation

1) Mach Measurement System

The stated Mach variability at the NTF is ± 0.001 M with target variability of ± 0.00025 M over the entire operational range (0.2 M to 1.2 M). The previous Flow Reference System (FRS) only performed at this required accuracy level approximately 60% of the time bringing into question data validity. More importantly, the FRS components were degrading and this was a system that was no longer supported by the manufacturer.



Figure 4. Mach Measurement System

A new two (2) sensor (150psia and 55psid) Mach Measurement System (MMS) has been implemented to improve Mach number control and provide at least a 5 times accuracy increase in Mach number measurement. The new system provides approximately 10 times better accuracy for dynamic pressure (Q) measurement resulting in a maximum Q error of 0.2 psf or less. The MMS also reduces annual calibration costs by 45%. This upgrade improves the overall NTF data quality requirements for tighter Mach number control (± 0.0005) and measurements resulting in better between series repeatability.

This effort included integration, programming, installation & evaluation of the MAIN pressure sensors described above. Two (2) additional pressure sensors (50psia and 14psid) designated as the LOW pressure range were also installed to further increase the MMS accuracy for low Mach number (0.3 or less) testing. This LOW system is manually selectable.

Figure 5 shows the measurement improvements between the FRS and the MMS for various tunnel configurations to be covered later. The measurement accuracy goal for a maximum Mach number range was set at 0.001 or better and it is clear that the FRS was no longer able to meet that goal.

2) Cooling Coil Trailing Edge Fairings

Three “quick mod” investigations were performed at the end of Test 203 to enhance facility data quality and / or facility performance. One of these mods looked at the addition of fairings on the trailing edges of the cooling coils (Figure 6). The fairings consisted of bent 1/16” aluminum sheet in a simple wedge shape to improve tunnel flow quality (Figure 7).

Data indicated an improvement (reduction of tunnel turbulence) with the addition of the fairings. These fairings were part of the original NTF tunnel design but were never installed (for unknown reasons). Approximately 600 lineal feet of fairings were installed onto the cooling coils. This resulted in reduced test section turbulence levels resulting in better data quality.

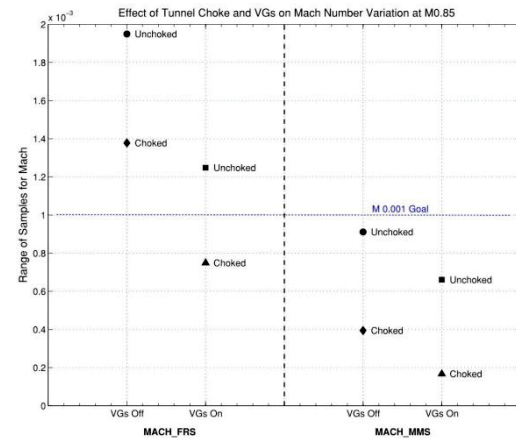

Figure 5.
MMS Improvement



Figure 6.
Cooling Coil Trailing Edge Fairings

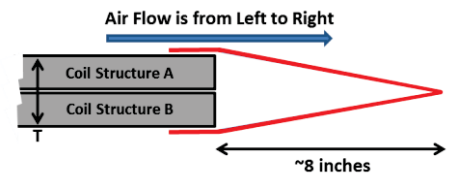

Figure 7.
Cooling Coil Fairing Schematic

3) Fixed Fairing Extensions

The model, balance, and sting are connected to the model support structure, herein termed the strut, which consists of the moveable arc sector quadrant (the forward half of the strut) and the aft aerodynamic body, termed the fixed fairing (Ref 4). The strut has a chord of 9.2 ft. (Figure 8). The trailing edge of the fixed fairing has a 40° included angle. A slightly longer fairing would have allowed a smaller trailing-edge angle, but was precluded due to clearance for the plenum test-section-isolation gate-valve mechanism at the downstream plenum bulkhead.

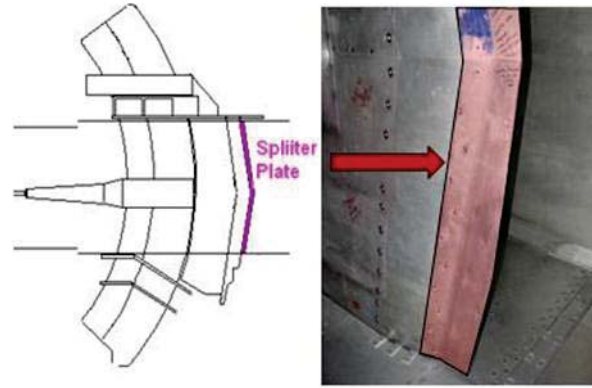

Figure 8. Fixed Fairing Extension

As a compromise to a major re-work of the fixed fairing to extend it, a clam-shell fixed fairing extension was designed and fabricated. This bolt-on extension increases the chord of the support strut and thereby the fineness ratio slightly. Data (high response pressure transducers) indicates the extension uniformly reduced flow turbulence levels by 3% to 6% in RMS turbulence from M=0.4 to 0.85, peaking at M=0.75 (red data) as measured using a 7 ft instrumented flow characterization rake upstream of the support system as compared to the extension off (blue) data (Figure 9).

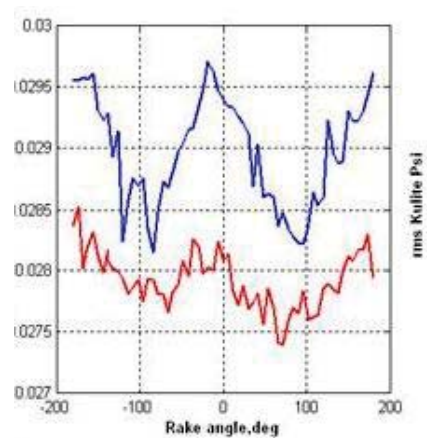

Figure 9. Fixed Fairing Extension Data (Red)

4) Alternate Probe Location (On Cooling Coils)

Analysis of the data from a tunnel test section characterization test using an instrumented 7 ft rake called into question the accuracy of the cooling coil instrumentation (thermocouples). The bulk of this apparent disagreement was in the accuracy ($\pm 2^\circ\text{F}$) of the thermocouples installed onto the cooling coils as compared to the accuracy ($\pm 0.1^\circ\text{F}$) of the RTD's installed on the rake. Improved accuracy of total temperature monitoring on the cooling coils was required.

PRT (Platinum resistance thermometers) in specially designed holders to measure total temperatures were placed in nine locations on the cooling coil in an approximate 10ft x 10ft grid. (Figure 10) Each instrument incorporated dual a PRT sensors and each location utilized dual instruments resulting in a total of 36 PRT sensors. These PRTs will provide a more accurate temperature mapping feature and provide a more stable total

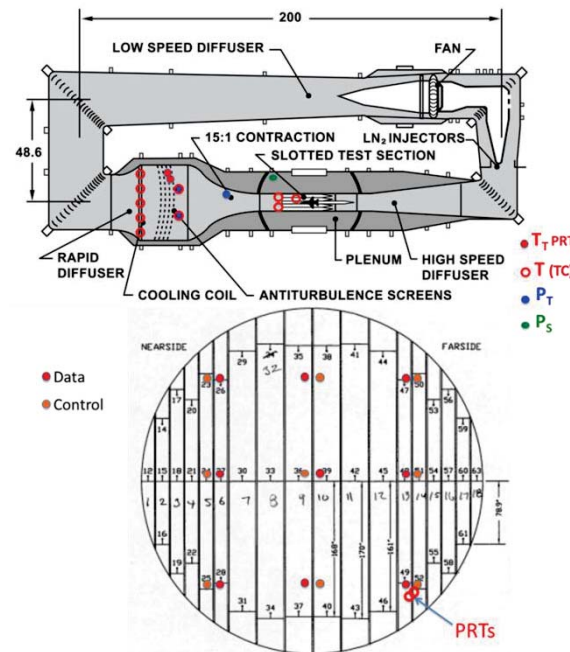

Figure 10. Temperature / Pressure Probe Locations

temperature measurement. Installation verification will take place during the next flow characterization test.

B. Productivity

1) Cryogenic Capable Active Damper

To reduce the amount and magnitude of aerodynamically induced model dynamics, an active Model Dynamics Damping System was developed. As a test bed for this effort the NTF Common Research Model (CRM) was utilized for development and check out purposes. (Figure 11) Testing in NTF air-mode (120° F), runs without the damper were forced to terminate at ~6° angle of attack. Runs with the damper active achieved ~12° angles. The system was also checked out at cryogenic temperatures. Even at -250° F, the actuators worked except that the energy level dropped to 20% of the level at ambient conditions; hence they were not as effective. The losses due to cryo temperatures resulted in a 80% loss of performance in energy capability; hence damper performance has been poor under cryogenic conditions.

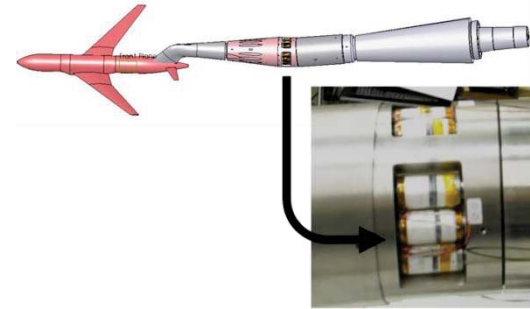

Figure 11.
Cryogenic Active Damper

This new effort utilized a modified CRM damper system that provided a heating system to maintain the piezoelectric actuator at approximately 120° F during cryogenic (-250° F) operations in the NTF. Fifteen (15) new piezoelectric actuators with end caps were modified to permit mounting of cartridge heaters. Thirty (30) new Vascomax end caps were fabricated. The heating system requires a minimum of 1200 Watts of power.

The new heated active damper system worked very well and maintained its performance level throughout the NTF temperature operating range.

2) Balance Limit Alarm Monitoring System (BLAMS)

The NTF Model Protection Safety System (MPSS) has provided failure free safety monitoring for the past 12 years without a single failure. However, the hardware technology has reached obsolescence and finding replacements for the DOS-ISA A/D cards has been challenging.

Also, the NTF has the reputation of limiting testing (pitch angle) compared to other facilities (ARC 11-Ft tunnel) testing the same model. The MPSS alarms / trips are based on the instantaneous peak load of 100% of the load limit estimated by Stress group and designated in NASA Langley



Figure 12.
Balance Limit Alarm Monitoring System

Procedure LPR 1710.15 - Wind-Tunnel Model Systems Criteria. At ARC 11-Ft, the BLAMS allows dynamic over load as long as its components are dictated by the Goodman algorithm. Because of this “softer” limit, higher pitch angles can be achieved.

The National Force Measurement Technology Center (NFMTC) initiated the development of a upgraded MPSS similar to the ARC BLAMS using contemporary software/hardware and digital signal processing (DSP) technology. (Figure 12)

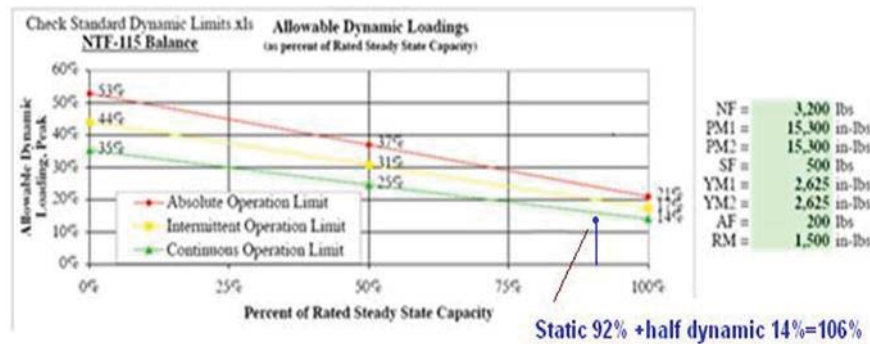

Figure 13. Modified Goodman Methodology

A standalone DSP based system duplicates all of the functions of the original MPSS. It also provides up to 500 Hz bandwidth with 100% signal tracking at the desired sampling rate and no loss of balance data readings. The BLAMS incorporates a simultaneous sample and hold capability and keeps a load log to evaluate fatigue history.

The system implemented changes to account for model weight and/or center of gravity . The system can preserve the functionality (limitations) of the previous MPSS or can utilize the ARC modified Goodman diagram philosophy in safety monitoring in the BLAMS mode (Figure 13) . This upgrade will allow for more data to be acquired because of the higher model pitch angle potential

C. Reliability

1) High Pressure Air Reducing Station

- 2) The NTF utilizes two high pressure air reducing stations to step-down center wide 5,000 psi air to 1,800 psi. These stations were old and getting difficult to maintain. They also took up valuable parking lot space where once stood the 16-Ft transonic tunnel.



Figure 14.
High Pressure Air Reducing Station

The stations (inside building) have been moved and upgraded. They are also located approximately 30% closer to NTF providing better response time to air commands. In addition to the closer proximity to the NTF, an air-storage bottle field and improved (vent valve) muffler system was located immediately adjacent to the facility for additional performance gains (Figure 14).

3) Drive Coupling Inspection

The Kopp Flex coupling transfers power from the 101MW NTF motor to the drive shaft (Figure 15). This unit, per manufacturer's recommendations requires inspection /maintenance every 5 years to ensure trouble free operation. This massive unit represents a critical lift endeavor that required the removal of an exterior building wall and external heavy lift crane.

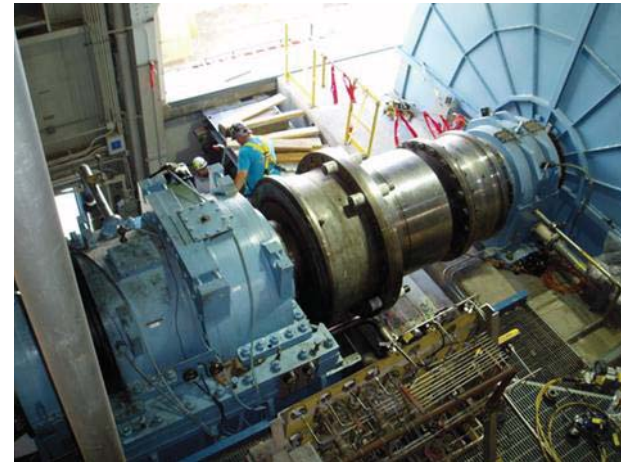

Figure 15.
NTF Drive Coupling

After removal the unit was cleaned and dimensionally checked by the manufacturer. Also, the coupling underwent a non-destructive evaluation inspection with no anomalies found.

Upon re-installation, axial end play measurements and concentricity measurements were made and the unit refilled with lubricant (grease). To aid in future removal, inspection, and re-installations, the entire process was video documented.

4) IGV Hydraulics Piping Repair

The Inlet Guide Vane (IGV) control system circulates heated fluid around hydraulic lines to improve performance at cryogenic temperatures (-250°F). This system has several bellows joints that allow for thermal expansion/contraction (Figure 16). One of two bellows in the IGV fluid lines within the forward nacelle developed a leak. The repair required removing part of the facility siding to allow two sections of pipe to be

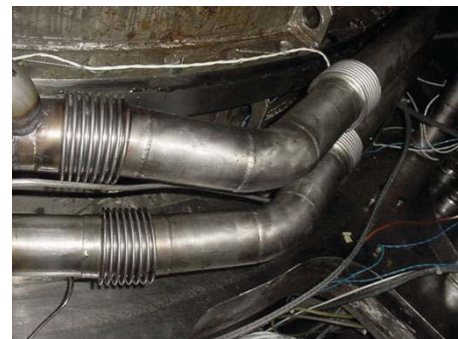

Figure 16.
Hydraulic Piping Bellows

removed and repaired. Because this is a recurring issue and repair will likely have many challenges, an alternative method to eliminate this recurring problem was devised based upon engineering analysis of the system.

The analysis looked at three cases; (1) unlined, (2) lined bellows replacements as well as (3) no bellows at all. The results of the analyses indicated a go-forward path is to eliminate the bellows in the piping. A bit counterintuitive but the analysis indicated that for the section in question, the bellows were a potential source for failure (leaks) with minimal benefit for expansion / contraction mitigation. The repair was performed eliminating the bellows.

IV. Validation / Calibration Tests

To verify and validate the improvements from the STARBUKS tasks, the NTF Pathfinder calibration model, the Common Research Model (CRM) and a centerline static pipe were used in four (4) separate test programs. These tests demonstrated that the accuracy, productivity, and reliability areas have been addressed satisfactorily or whether more work is required. What follows is a very brief description of each test conducted and some very high level conclusions (data) as each test is worthy of its own paper.

A. Test 214 - Pathfinder Check Standard

The NTF Pathfinder check standard model and 113b balance were utilized for this air only (non-cryo) test program (Figure 17). This test was a repeat of Pathfinder tests conducted over the last 11 years and represents a very good measure for a Statistical Quality Control (SQC) measure of the facility. The model as depicted in Figure 16 has a wingspan of approximately 53 inches. The goals of this test program were to 1) obtain repeatable check standard air data; 2) obtain long duration/high sample rate data to help evaluate conditional data sampling; 3) perform continuous sweep runs to mitigate any problems before the CRM test and 4) verify a correction method for inverted check standard polars (Reference 6).



Figure 17.
Pathfinder Calibration Model

Testing was performed at the following test conditions:

- Mach number: $0.189 \leq M \leq 0.800$
- Dynamic Pressure: $176 \text{ psf} \leq q \leq 2425 \text{ psf}$
- Reynolds number: $1.9 \times 10^6 \leq Re \leq 10.7 \times 10^6$ (based on model chord)
- Total Pressure: $16.0 \text{ psi} \leq PT \leq 114.0 \text{ psi}$

- Temperature: +120.0° F
- Angle-of-Attack: $-2^\circ \leq \alpha \leq +2.5^\circ$

The test verified excellent in-test drag coefficient repeatability and was well within the 10+ year SQC chart (Figure 18). Continuous pitch sweep data checkout was conducted and provided mixed results. After further investigation, the observed discrepancies were attributed to inadequate time alignment of the various data systems. This effort is still underway and should be a relatively easy correction once the temporal differences are determined. Long duration data sampling (2 seconds of data at a 400 Hz sampling rate) was also obtained. Large amounts (4800 samples per data point) of data arithmetically averaged produce very good results.

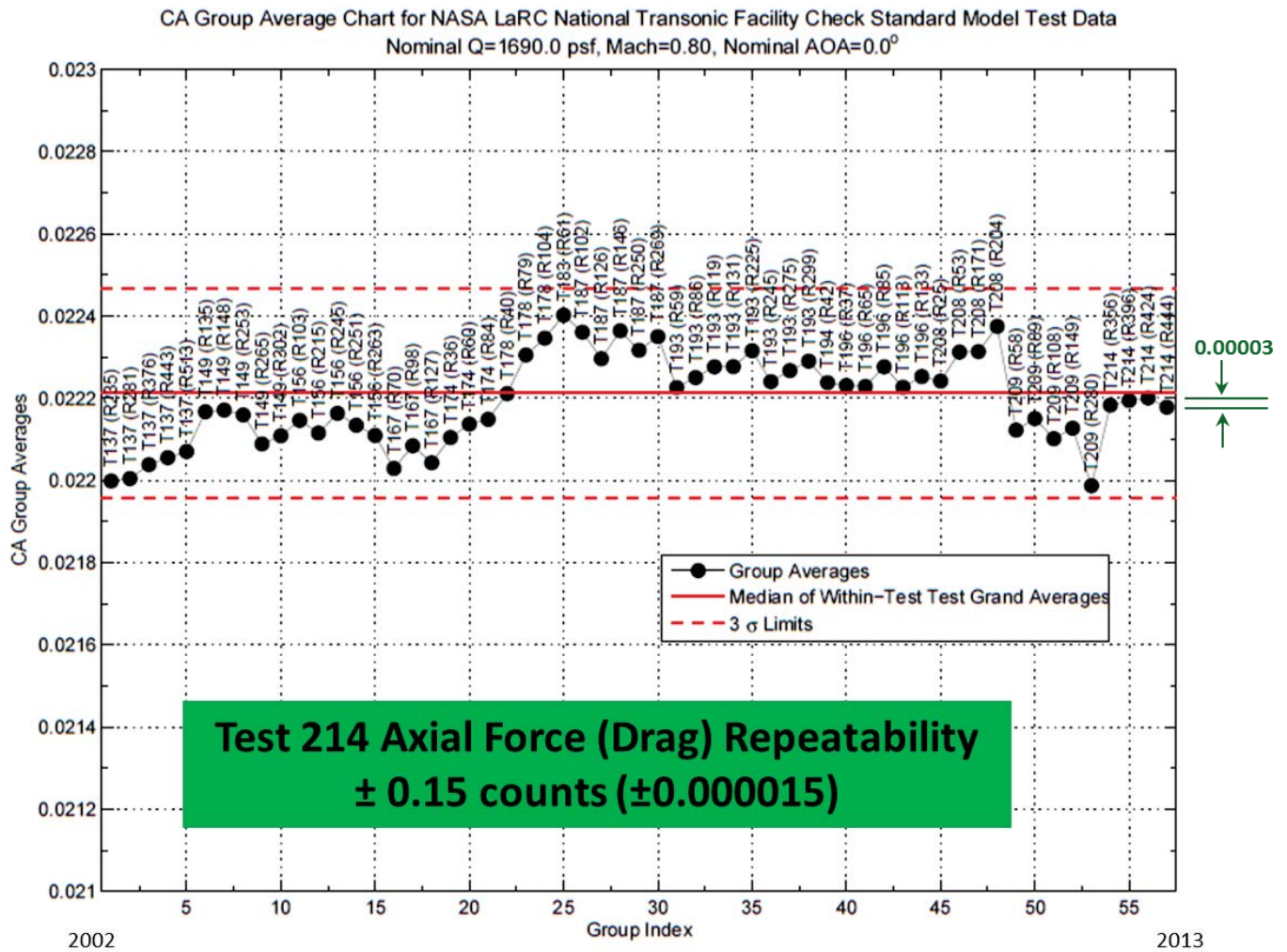

Figure 18.
Pathfinder SQC History

B. Test 215 - Common Research Model (CRM)

The CRM and the 118a balance were used for additional STARBUKS check out. The CRM is a full-span, 2.7% scale model that consists of a mix of 2.7% Boeing 777 model parts and CRM

model parts having a 62.47 inch wingspan (Figure 19). This model has a published (public) database that serves as the baseline for data comparisons (Reference 7).

The objectives of this test were 1) Quantify effects of tunnel upgrades on data quality and repeatability; 2) Demonstrate improved effectiveness of the active damper at cryogenic test conditions; and 3) Add to the open CRM database.

This wind-tunnel experiment was a critical milestone in the STARBUKS project at the NTF. Testing was performed at the following test conditions:

- Mach number: $0.700 \leq M \leq 0.870$
- Dynamic Pressure: $1150 \text{ psf} \leq q \leq 2015 \text{ psf}$
- Reynolds number: $5.0 \times 10^6 \leq Re \leq 30.0 \times 10^6$ (based on model chord)
- Total Pressure: $28.60 \text{ psi} \leq PT \leq 49.05 \text{ psi}$
- Temperature: $-250^\circ \text{ F} \leq TT \leq 120.0^\circ \text{ F}$
- Angle-of-Attack: $-3^\circ \leq \alpha \leq +12^\circ$

Data comparisons between CRM test were good. All within-test Mach 0.7 data were repeatable and much better than previous test entries. There were mixed repeatability results at Mach 0.850 which were initially attributed to Mach instability.

Good active damper performance was obtained with AoA being increased ($> 6^\circ$) at many conditions. Higher AoA could be obtained if the model was pitched through the high dynamic region with no pauses for data. The MMS measurements resulted in data that was significantly better than FRS. Drag repeatability (in test) showed dependency with alpha at Mach 0.85

- $\alpha \leq 2^\circ$ very good... $CD = \pm 0.00002$
- $\alpha > 2^\circ$ not so good... $CD = \pm 0.00020$

In addition to the data achievements, the time between data points was reduced by operating in the pitch / roll (θ/ϕ) method of setting AoA rather than alpha / beta (α/β). Polar times were reduced from 7 minutes per polar to 4 minutes per polar thereby saving ~ 200 tons of LN2 per series.

The most notable improvement was the use of conditional sampling based upon Mach number tolerance (Figure 20). While further refinement and automation of the process is required to



Figure 19.
Common Research Model (CRM)

make it a “real-time” feature of the facility, the results have been very impressive as shown below:

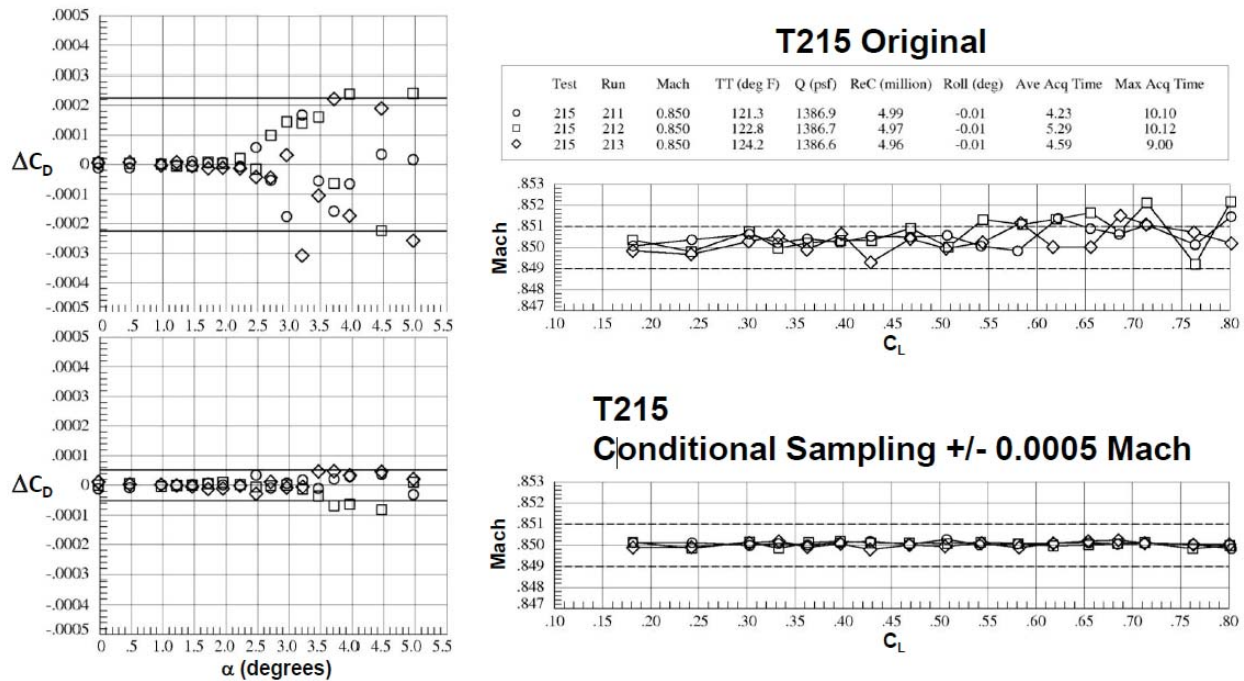

Figure 20.
Conditional Sampling Comparison

C. Test 217 - Centerline Static Pipe

Utilizing the NTF centerline static pipe, this test was used to check the calibration of the NTF with respect to centerline Mach number distribution. The pipe has a total of 320 orifices in 4 longitudinal rows situated orthogonally (Figure 21). This data is used to create correction factors to all collected wind tunnel data (Reference 7). Recommended (AIAA) frequency for this type of calibration is once every 5 years. It has been approximately 15 years since the last tunnel calibration at NTF so this check calibration was well over due.

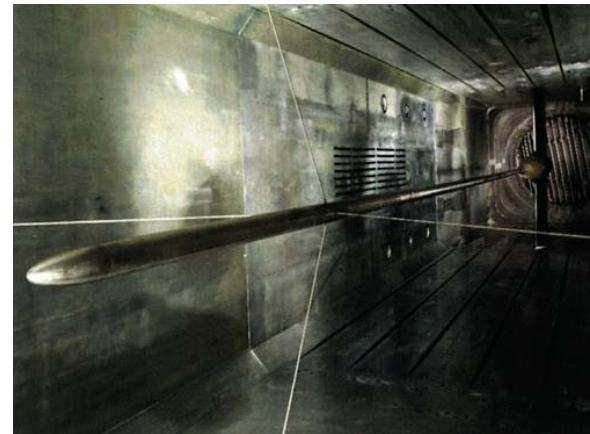

Figure 21.
Centerline Static Pipe

The test section Mach number distribution was determined as a function of total pressure, temperature, and Mach number. An empty tunnel wall signature over the full range of tunnel operation was also obtained. The individual objectives of the test were:

1. Characterize the NTF test section Mach number and Mach gradient along the longitudinal centerline of the test section for the range of tunnel operating conditions up to a dynamic pressure of 3500 psf.

2. Determine the uncertainty of the Mach number and Mach gradient measurements.
3. Characterize the fan performance over the operating range of the tunnel up to a dynamic pressure of 3500 psf.
4. Characterize the NTF test section wall pressures and correlate with the appropriate test parameters.
5. Determine the effects (if any) of the Sidewall Model Support System (SMSS) using a simulated displacement volume for the SMSS

Testing was performed at the following test conditions:

- Mach number: $0.200 \leq M \leq 1.200$
- Dynamic Pressure: $79 \text{ psf} \leq q \leq 3526 \text{ psf}$
- Reynolds number: $1.7 \times 10^6 \leq Re \leq 106.1 \times 10^6$
- Total Pressure: $20 \text{ psi} \leq PT \leq 49.05 \text{ psi}$
- Temperature: $-250^\circ \text{ F} \leq TT \leq 120.0^\circ \text{ F}$

The pipe data obtained agreed reasonably well with the previous tunnel calibration (Test 100) generated curve fits (table lookup). The airline configuration between the two tests is slightly different. Test 217 includes the cooling coil fairings, fixed fairing extension, and SMSS simulator installed (Figure 22).

The buoyancy ($\delta M / \delta X$) has a slightly different characteristic than the previous pipe data however it is still small. Using the CRM area distribution, at Mach 0.85 this difference would equate to a 0.1 count change in CD and about a 0.5 count change at Mach 0.5.

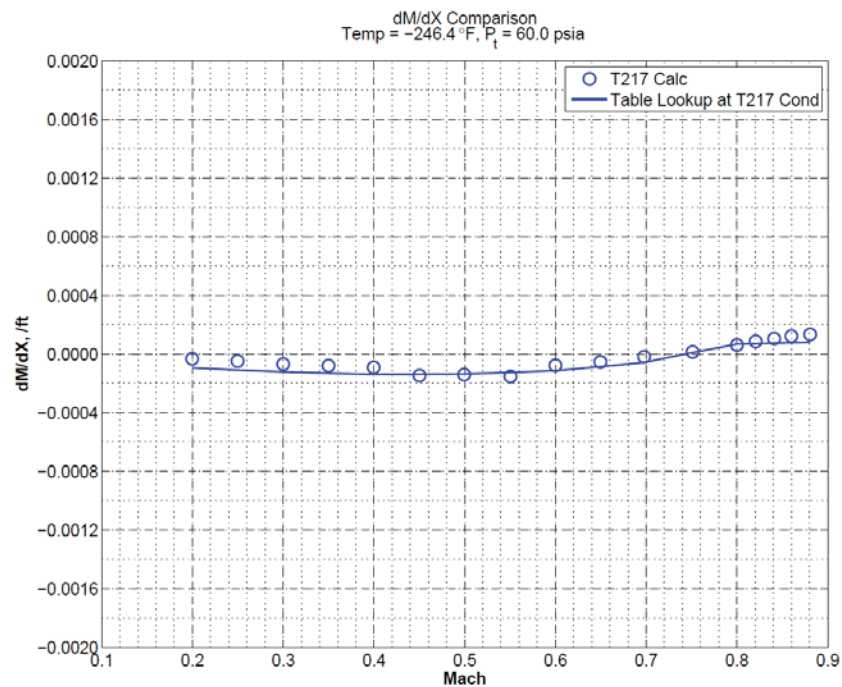

Figure 22.
Station 13 $\delta M / \delta X$ Comparison

Having the centerline pipe in the tunnel (a relatively rare occurrence) prompted us to use its availability to investigate / validate some different facility configurations in an effort to improve overall performance. These tunnel and acquisition/control changes included:

- Choked Tunnel (using model support walls and re-entry flaps)
- Diffuser Vortex Generators (floor, ceiling and walls)

- Arc Sector Vortex Generators (Figure 23)
- Mach Number Control with MMS
- Narrow ATS Mach Tolerances
- Locked IGV Control
- LN2 Injector Pattern Optimization
- Static Pressure Probe Transient Flow Attenuator

D. Test 218 - Common Research Model (CRM)

This NTF experiment was conducted to investigate and improve Mach number control above Mach 0.80. Data analysis had shown that a correlation exists between Mach number variability and drag coefficient variability. Consequently, it was hypothesized that if Mach variability can be reduced, drag repeatability will be improved. NTF Test 215 (CRM) and the force and moment data acquired during the test served as the benchmark by which all of the data from Test 218 was compared.

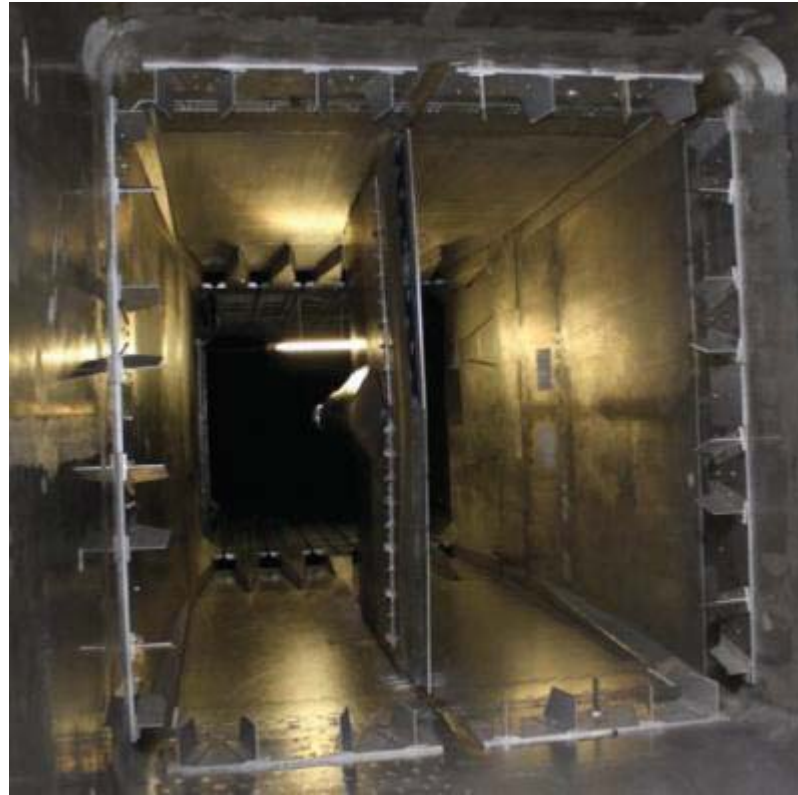

Figure 23.
Vortex Generators

The primary objectives of Test 218 were 1) demonstrate reduced variability in Mach number, especially at Mach 0.85; 2) demonstrate reduced variability in drag, especially above 2° angle-of-attack; and 3) visualize the surface flow in the high-speed diffuser (Reference 8).

The setup for Test 218 mirrored that of NTF Test 215. Experimentation with the test section movables were conducted during NTF Test 216 to obtain experience / data with the tunnel choked. It was hypothesized that choking the tunnel with the test section movables will decrease Mach variability in the test section, thereby improving data quality. It was also hypothesized that the flow in the high speed diffuser may be separating at higher model angles-of-attack. Therefore, re-energizing the diffuser flow was also investigated using vortex generators (VGs). Large tufts be affixed to the floor of the high-speed diffuser were used to visualize the flow aft of the model support system.

Testing was performed at the following test conditions:

- Mach number: $0.700 \leq M \leq 0.870$
- Dynamic Pressure: $1150 \text{ psf} \leq q \leq 1408 \text{ psf}$

- Reynolds number: $5.0 \times 10^6 \leq Re \leq 19.8 \times 10^6$ (based on model chord)
- Total Pressure: $28.60 \text{ psi} \leq PT \leq 33.78 \text{ psi}$
- Temperature: $-250^\circ \text{ F} \leq TT \leq 120.0^\circ \text{ F}$
- Angle-of-Attack: $-3^\circ \leq \alpha \leq +6^\circ$

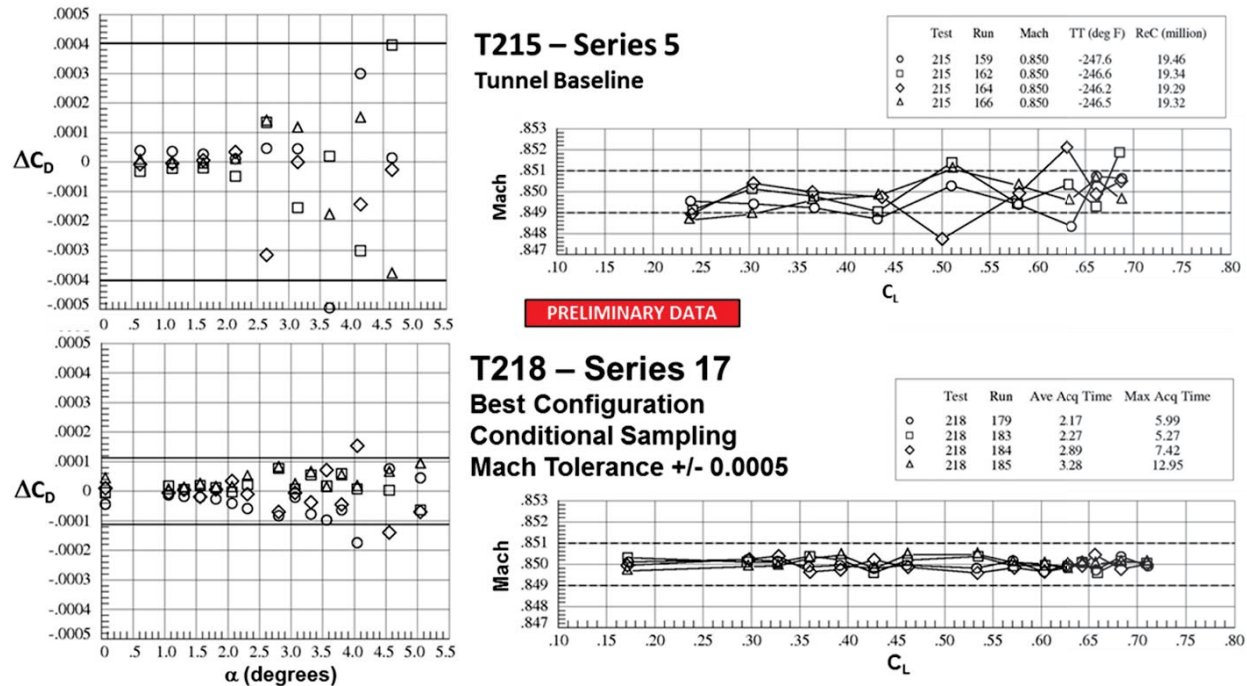

Figure 24.
Cryo Conditional Sampling Comparison

Based upon the data obtained and reviewed to date, the “best” configuration for M0.85 was (Figure 24):

- Tunnel Choked @ M0.9 (choking the tunnel provides the largest stabilizing benefit)
- All VGs On + Arc Sector VGs (optimum configuration yet to be determined)
- MMS Mach Control using a tight ATS Mach Tolerance (0.0005)
- Active Damper On

More experimentation / optimization is required on all of the above variables to ensure consistent high quality repeatable data. In summary for Test 218, using the above techniques, the NTF has demonstrated:

- An approximate **2:1** drag variability decrease in air mode
- An approximate **4:1** drag variability decrease in cryo mode

V. Conclusions

Several upgrade projects have been completed at the NASA Langley Research Center National Transonic Facility over the last 1.5 years in an effort defined as STARBUKS - Subsonic Transonic Applied Refinements By Using Key Strategies . This multi-year effort has enhanced NTF's overall capabilities by improving the Accuracy and Validation, Productivity, and Reliability capabilities at the NTF. The NTF is continuing its process of flow improvement and data optimization to satisfy its customer's ever increasing requirements for high fidelity data.

Acknowledgements

I would like to acknowledge all of the hard work and long hours the entire staff of the NTF contributed to the success of the STARBUKS effort. Some of the tasks and inevitable changes that went along with them required a very agile group of dedicated individuals. Of special note are Scott Goodliff (Jacobs / ROME Test Engineer), David Chan (NASA Researcher) and Eric Walker (NASA Researcher) who spent countless hours analyzing the data obtained from the various tests. Thank you all for making the NTF a much better facility.

I would also like to thank the NASA Aeronautics Test Program Manager Tim Marshall, LaRC Research Directorate Deputy Director Allen Kilgore, and LaRC Center Director Lesa Roe for their continued financial support and guidance to ensure the NTF remains a world class testing facility.

Disclaimer of Endorsement

Neither the U.S. Government nor NASA endorse or recommend any commercial products, processes, or services. Reference to or appearance of any specific commercial products, processes, or services by trade name, trademark, manufacturer, or otherwise, in NASA materials does not constitute or imply its endorsement, recommendation, or favoring by the U.S. Government or NASA and are presented for reporting purposes only. The views and opinions of the author(s) expressed in this report do not necessarily state or reflect those of the U.S. Government or NASA, and they may not be used for advertising or product endorsement purposes.

References

¹Paryz, R. W., “Selected Major Modifications To The National Transonic Facility,” 49th AIAA Aerospace Sciences Meeting, Paper AIAA 2011-877, 4 - 7 January 2011, Orlando, Florida.

²Paryz, R. W., “Upgrades at the NASA Langley Research Center National Transonic Facility,” 50th AIAA Aerospace Sciences Meeting, Paper AIAA 2012-0102, 09 - 12 January 2012, Nashville, Tennessee

³Venkat, V. S. , Paryz, R. W., Bissett, O. W., and Kilgore, W. A., “Inlet Guide Vanes Thermal Gradient Mitigation In the NASA Langley Research Center National Transonic Facility,” 51st AIAA Aerospace Sciences Meeting, Paper AIAA 2013-0868, 07 - 10 January 2013, Grapevine (Dallas/Ft. Worth Region), Texas

⁴Edwards, J. W., NASA Langley Research Center, Hampton, Virginia 23681, “National Transonic Facility Model and Tunnel Vibrations,” AIAA Journal of Aircraft, Vol. 46, No. 1, January–February 2009

⁵NASA Langley Research Center, Hampton, Virginia 23681, “Wind-Tunnel Model Systems Criteria – LPR 1710.15,” Revised 28 January 2009

⁶Revnaugh, J., NASA Langley Research Center, Hampton, Virginia 23681, “National Transonic Facility Test 214 Test Requirements - Check Standard, Version 2,” 19 February 2013

⁷Goodliff, S. L., NASA Langley Research Center, Hampton, Virginia 23681, “National Transonic Facility Test 215 Test Requirements – Common Research Model (CRM), Version 2,” 28 May 2013

⁸Bailey, M. M., NASA Langley Research Center, Hampton, Virginia 23681, “National Transonic Facility Test 217 Test Plan and Requirements – Tunnel Calibration Centerline Probe Test, Version 2,” 17 June 2013

⁹Goodliff, S. L., NASA Langley Research Center, Hampton, Virginia 23681, “National Transonic Facility Test 215 Test Requirements – Common Research Model (CRM), Version 3,” 23 August 2013