

# Robotics for Human Exploration

Terrence Fong<sup>1</sup>, Matthew Deans<sup>1</sup>, and Maria Bualat<sup>1</sup>

<sup>1</sup>Intelligent Robotics Group, NASA Ames Research Center, Moffett Field, California USA

**Abstract:** Robots can do a variety of work to increase the productivity of human explorers. Robots can perform tasks that are tedious, highly repetitive or long-duration. Robots can perform precursor tasks, such as reconnaissance, which help prepare for future human activity. Robots can work in support of astronauts, assisting or performing tasks in parallel. Robots can also perform “follow-up” work, completing tasks designated or started by humans. In this paper, we summarize the development and testing of robots designed to improve future human exploration of space.

**Index Terms:** Human-robot interaction, mobile robotics, planetary exploration, space robotics

## I. INTRODUCTION

Future human missions to the Moon, Mars, and other distance worlds offer many new opportunities for exploration. But, astronaut time will always be limited and some work will not be feasible for humans to do manually. Robots, however, can complement human explorers, performing work autonomously and under remote supervision from Earth. A central challenge, therefore, is to understand how human and robot activities can be coordinated, in both space and time, to increase mission success and scientific return [8][9].

As advanced as robots have become, however, they are still slow compared to humans. Thus, when robots are used as “field assistants” (e.g., [2][10][14]), humans often have to wait for the robot, i.e., while it is performing a task or “catching up”. Waiting wastes precious resources, such as mission time or life support consumables (oxygen, water, etc), which risks making human missions less productive rather than more. To avoid this problem, we argue that it is better to separate human and robotic activities in space and/or time, but design and coordinate their activities to be complementary [4][11].

## II. ROBOTIC RECON

Robotic recon is a remote robotic operation to scout planned sorties before human extra-vehicular activity (EVA) [3]. Scouting is an essential phase of scientific fieldwork, particularly for geology, and can be: (1) traverse-based (observations along a route); (2) site-based (observations within an area); (3) survey-based (systematically collecting data on transects) or (4) pure reconnaissance. With robotic recon, science instruments mounted on a planetary rover provide measurements of the surface (and subsurface) at resolutions and from viewpoints not achievable from orbit. This surface-level data can then be used to inform the planning process and to improve situation awareness for operations [1][6].

There are two different ways that robotic recon can help develop traverse plans. The first is to conduct recon far in advance of crew missions, to develop overall EVA traverses and tasks along the traverse. We refer to this mode as “advance recon”. The second is to design a notional EVA traverse plan using remote sensing and any other existing information, then conduct robotic recon along the planned route. Observations made along the route are then used to modify tasks and adjust priorities. We refer to this as “lead scouting”.

Advance recon offers more freedom in route planning, but requires significantly more lead-time (for both execution and data analysis) and potentially greater coverage of putative EVA areas. Lead scouting offers a more targeted study of a designed EVA route, but can provide information to adjust the overall plan to maximize scientific return. Lead scouting potentially takes less time to perform, but may be required to return data in real-time to support concurrent decision making.

### A. Robotic Recon Experiment

In 2009, we conducted a robotic recon field experiment at Black Point Lava Flow, Arizona, USA as part of NASA’s Desert Research and Technology Studies (Desert RATS)[13]. We used the K10 planetary rover [5] (Figure 1) to explore planned traverses, which were subsequently carried out by astronauts driving the “Lunar Electric Rover” (LER), as shown in Figure 2, and performing fieldwork while wearing space suits. We designed the experiment to improve our understanding of how robotic scouting can help plan EVAs and how robots might best complement human crews [1].

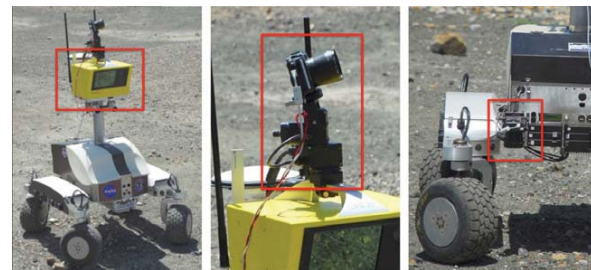

**Figure 1. K10 planetary rover equipped with instruments: 3D scanning lidar (left), panoramic imager (center), terrain imager (right).**

The goal of the field experiment was to assess the effect of robotic recon on EVA traverse planning and crew performance. The study focused on two primary objectives: (1) examine the extent to which robotic recon can reduce uncertainty and improve traverse planning

(prior to human field work) and (2) examine route, stops, and science targets in depth prior to EVA in order to improve crew efficiency and data collection quality.



**Figure 2. The Lunar Electric Rover (LER) is a prototype astronaut vehicle for planetary surface exploration during future human missions.**

This experiment took place in four phases (Figure 3): “Pre-Recon”, “Robotic Recon Mission”, “Pre-LER”, and “LER Mission”. In the “Pre-Recon” phase, which took place during Spring 2009, the traverse planning team planned two traverses, *N1* and *W1* (corresponding to the North and West areas) of the Black Point Lava Flow using satellite images and existing geologic maps. The team also identified high priority areas where more detailed information was needed from ground level to better assess the science merit of a particular location, or to better assess the accessibility, or trafficability, of the path or location.

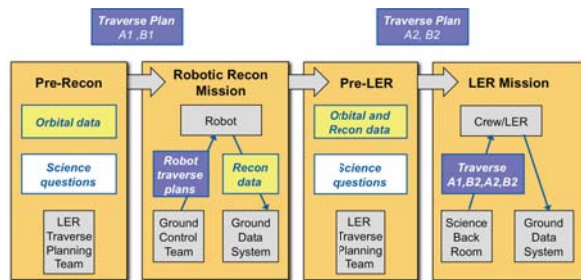

**Figure 3. The 2009 Robotic Recon Experiment was carried out in four phases.**

During the “Robotic Recon Mission” phase (June 14 – 26, 2009), we remotely operated K10 from a control center at NASA Ames (Moffett Field, California, USA) to collect imagery, video, instrument data, and operational experience from the two planned traverses (*N1* and *W1*). We also recorded video and voice loops from the ground control team, and collected notes and statistics from operations for later analysis. Figure 4 shows an iconic view of the recon data that was collected: 95 microscopic terrain images are shown as yellow “M” icons, 39 lidar scans are shown as pink “L” wedges, and 75 panoramas are indicated as green “P” wedges.



**Figure 4. Recon data collected with the K10 rover for the *W1* (blue) and *N1* (orange) traverses.**

The “Pre-LER” phase (June 27 – September 1, 2009) took place after the robotic recon mission. During this phase, the original traverses were updated using information collected by K10 to generate revised traverse plans, *N2* and *W2*. Science priorities, operational issues, and details about the site that were not detectable from satellite imagery all influenced the plans. The changes in the plans were evaluated to quantify the impact of recon on mission planning before the plans were even executed.

Finally, in the “LER Mission” phase (September 1 – 18, 2009), the LER crew carried out all four traverse plans (*N1*, *N2*, *W1*, and *W2*) with real-time support from a ground control team. We recorded voice loops, logged robot telemetry, and made notes throughout operations for later analysis.

As a control, a field geologist collected ground truth for, and evaluated, each *pre-* and *post-* recon science target and each recon target. This included deleted targets from the original “pre-recon” traverse plans, and recon targets that were not added to revised “post-recon” plans.

## B. Results

We found that robotic recon was of major benefit to the West region, because the pre-recon traverse (*W1*) emphasized rapid area coverage and visited several different, widely separated geologic units. From a planning standpoint, this meant that there was a large set of unknowns that recon helped resolve, in terms of target access (trafficability, route, approach direction) and science priorities.

In particular, a majority of the stations were changed between the pre-recon (*W1*) and post-recon (*W2*) traverses based on data acquired by robotic recon. In addition, because EVAs were potentially numerous in the West, recon information was essential for prioritizing fieldwork. This was especially true during the *W2* traverse, when the ground control team was required to make real-time replanning decisions to accommodate time constraints and changing priorities. In other words, recon enabled greater operational flexibility during *W2*, which enabled all the high priority science objectives to be achieved even under difficult field conditions.

Robotic recon was of less benefit to the North region, primarily because the pre-recon traverse (*NI*) had a narrower scientific objective, i.e., characterize the overall lava flow and its contact with the underlying geologic unit. In addition, the recon instruments carried by K10 had limited capability to address this objective. If K10 had been equipped with additional instruments (e.g., spectrometers), recon could have focused on identifying and classifying candidate targets for sampling.

Consequently, the *NI* traverse had fewer scientific uncertainties that could be resolved by the robotic recon than the *WI* traverses. As a direct result, the northern recon focused primarily on reducing operational unknowns, i.e., verifying that the planned route and waypoints were trafficable for the LER (in terms of slopes, obstacles, etc.), identifying and improving precise locations for LER stops (including approach and departure directions), etc. Only two stations were significantly changed based on robotic recon.

After all the traverses were complete, we interviewed the crew and asked what recon information would have been the most useful to have on-board the LER. Their responses fell into two categories: (1) data to improve situational awareness, such as images of navigation and approach/ departure landmarks; and (2) guidelines for operations (e.g., surface roughness map) to help LER driving and EVA work (e.g., where and what to sample).

We also encountered anecdotal evidence of the improvement in crew situational awareness. During the *N2* traverse, the crew and back room had difficulty navigating and communicating due to radio problems, but when the crew visually spotted a terrain feature that had been prominent in a recon image, they were able to rapidly orient themselves and to determine which way to drive. It is not clear whether that same visual recognition would have happened without the high resolution and ground based perspective of robot recon data.

### III. ROBOTIC SUPPORT

Robotic support means having robots support, without encumbering, astronauts during human missions. In contrast to “robotic assistance”, which closely couples robots to human explorers (e.g., as “pack mules” [14]), robotic support focuses on scenarios where robots can work in parallel, but loosely coupled with astronauts.

One form of robotic support is to remotely operating a planetary rover equipped with science instruments (cameras, 3D scanning lidar, etc) concurrently with humans. This is similar to how mission control remotely operated a color television camera on the Lunar Roving Vehicle during Apollo. The primary motivation for doing this is to enable ground control personnel, particularly scientists and mission analysts, to more directly and effectively support astronauts during EVA. In particular, data from robot instruments can be used to assist site analysis, sample targeting, and documentation.

#### A. Robotic Support at Desert RATS 2010

In 2010, we used the ‘Gigapan Voyage’ robot camera (Figure 5) to support remote science operations during a lunar mission simulation conducted by NASA’s Desert RATS project [6]. The simulation involved astronauts performing field geology traverses in the Lunar Electric Rover (LER), which included stops at various locations (“EVA stations”) for manual geologic mapping and rock sampling work. At each station, while the crew performed EVA, a science team remotely operated a Gigapan Voyage mounted on top of the LER (Figure 6) to acquire a variety of color panoramic images. These panoramas were analyzed in real-time and used to guide fieldwork in several ways: identified zones/targets of interest, prioritized and ordered work locations, classified and prioritized samples to be collected, etc.



**Figure 5. Gigapan Voyage is a remotely operated robotic camera for acquiring very high-resolution panoramic images.**

Gigapan Voyage is a remotely operated robot camera that we developed to capture very high-resolution (greater than one gigapixel) panoramic images by capturing and mosaicking a sequence of overlapping images [6]. The system consists of an off-the-shelf, consumer grade digital camera mounted on a computer controlled pan-tilt head. A laptop computer equipped with a GPS sensor commands the pan-tilt head to orient the camera, remotely triggers the camera to acquire a set of images, performs image alignment and stitching (mosaicking), and records appropriate metadata (geospatial coordinates, time, imaging parameters, etc) with the resulting panorama. A web interface allows users (e.g., scientists) to remotely command Gigapan Voyage and to access (browse, search, and download) the individual images and derived panoramas.



**Figure 6. Gigapan Voyage mounted on the Lunar Electric Rover during Desert RATS 2010.**

### B. Results

Over a period of 11 days, the science team captured more than 200 panoramas using Gigapan Voyage. Each time the LER arrived at a designated EVA station, the science team immediately acquired a “survey panorama”. A survey panorama is a wide area panorama that contains 6 to 20 individual images and requires approximately less than 5 min to acquire and mosaick. This relatively low-resolution panorama allowed the science team to quickly choose which regions of the panorama were scientifically interesting. They then proceeded to take higher resolution panoramas of those regions. Since higher resolution panoramas can take significantly longer to acquire and stitch than simple survey panoramas, the raw images were made available to view immediately.

As the science team gained more experience and comfort with Gigapan Voyage throughout the test, they increasingly used the system to gather panoramas with three to four times more detailed information – even though taking larger panoramas required significantly longer acquisition times. For example, a standard “survey panorama” consisting of 20 images (2 rows of 10 images) typically took 2.5 min to acquire and 2.5 min to mosaick, while a “high-resolution” 47x11 panorama took about 50 min to acquire and 3 hr to stitch. Figure 7 shows an example of a high-resolution panorama.

At the completion of the field experiment, science team members were given a questionnaire to assess their experience with Gigapan Voyage and its data products. Thirteen members of the field science team responded:

- Nine of the respondents (69%) rated the system a four on a five-point Likert scale. A rating of five indicates that the system was *critical* for their situation awareness.
- Four of the respondents (31%) gave the system a rating of three, which indicates that the data partially contributed to their situation awareness.
- None of the respondents felt the panorama acquisition and processing time caused delays to the astronaut mission.

- Nine of the respondents (69%) indicated that the final data product was of good, or great, quality.
- None of the respondents indicated that the data was of poor quality.

In short, robotic support using the Gigapan Voyage was generally found to significantly enhance the situation awareness of the science team, to significantly improve site analysis and targeting, and to significantly increase the ability of ground control team to remotely support astronauts performing EVA fieldwork.



**Figure 7. Panoramic image of basalt wall (top); Zoomed view (bottom).**

## IV. ROBOTIC FOLLOW-UP

Robotic follow-up is a remote robotic operation subsequent to human EVA or missions, which augments the work accomplished by humans. The primary purpose of robotic follow-up is to acquire additional data that is complementary and supplementary to what was previously collected [4][7]. We can imagine robotic follow-up being performed with equipment (e.g., crew rovers) left behind by human missions, or using dedicated planetary rovers.

Robotic follow-up might involve completing geology observations (documenting areas of secondary priority), making repetitive or long-duration measurements (e.g., transect survey), and performing “unskilled” fieldwork (digging, transporting instruments, etc). Robotic follow-up might be carried out immediately after humans leave a site. This could require robots to complete work started by humans. Robotic follow-up might also be carried out far after a human mission ends. This would allow greater planning to be performed prior to robot activity, but might not allow synchronized measurements to be made.

### A. Robotic Follow-up Experiment

During 2009-2010, we conducted a robotic follow-up field experiment at Haughton Crater, Devon Island, Nunavut, Canada [7]. We first performed a simulated human lunar mission, which involved geologic mapping of the major lithologic units and geophysical survey of the near-subsurface. Subsequently, we used the K10 planetary rover to perform additional fieldwork. We designed the experiment to improve our understanding of how robotic follow-up can help improve the overall productivity of human-robotic exploration.

The experiment had three objectives: (1) investigate the operational requirements for robotic follow-up at an analog site relevant to lunar science priorities and science operations, (2) investigate the ground control and science operations structure requirements for robotic follow-up, and (3) investigate how follow-on robotic fieldwork can enhance and complete tasks performed by humans.

The experiment took place in three phases (Figure 8): “Mission Planning”, “Crew Mission”, and “Robotic Follow-up Mission”. In the “Mission Planning” phase (Spring 2009), a science team planned fieldwork using remote sensing data comparable to what is expected to be available for future lunar missions. Data included digital elevation models (14 m/post), a panchromatic satellite orthophoto (60 cm/pixel), black-and-white aerial photos, Landsat Band 8 (14 m/pixel), ASTER (100 m/pixel), and aerial radar (100 m/pixel).

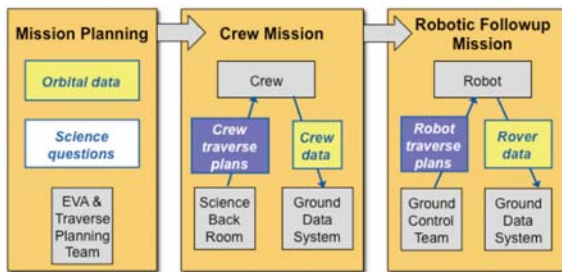

**Figure 8. The 2010 Robotic Follow-up Experiment was carried out in three phases.**

During the “Crew Mission” phase (July 2009), we conducted the simulated lunar crew mission. A geologist, a geophysicist, and a planetary scientist used a HMMWV as a simulated pressurized crew rover (Figure 9). Each traverse was performed by a two-man crew and included short EVAs on foot with unpressurized concept space suits. To more closely simulate a future lunar mission, we constrained all traverse plans to follow a set of flight rules (including constraints on driving speeds, sortie times, etc), which reflect recent lunar exploration architectures developed by NASA.



**Figure 9. Concept space suits and a HMMWV were used as part of a human lunar mission simulation.**

Finally, in the “Robotic Follow-up Mission” phase (July 19 – August 8, 2010), we used the K10 planetary rover to carry out fieldwork based on what had been done (and not done) during the crew mission (Figure 10). We remotely operated K10 from a control center at NASA Ames (Moffett Field, California, USA). K10 was equipped with cameras, a 3D scanning lidar, a ground-penetrating radar, and an XRF spectrometer.



**Figure 10. K10 planetary rover operating in the Houghton impact structure on Devon Island.**

## B. Results

We found that robotic follow-up can be extremely useful for enhancing geological mapping. In particular, K10 enabled us to further evaluate the structure of the inner wall of Houghton Crater, to map faults/fractures in rocks proximal to the crater rim, and to better understand the target sequence stratigraphy. For geophysical survey applications, we learned that robotic follow-up can provide precise metrics for quantifying the volumes, depths, concentration, and distributions of subsurface ice.

At one location, Site A, one of our objectives was to use robot data to test, verify, and amend the geologic map developed by the crew mission. Several images taken by K10 provided useful views of the marker beds in the host carbonate stratigraphy. We analyzed two of these images and compared them to satellite orthophotos to determine marker bed continuity and possible fault offset. In a number of places, the K10 images supported initial interpretations, or were sufficient for re-interpretation of the map. In other locations, however, the robot data was not informative enough to verify (or amend) the map.

At Site A, we also studied ground “polygon” features, which had been identified during the crew mission. Image data from K10 were used to measure surface roughness, grain sizes, and composition. Lidar was used to observe 3D surface features, particularly crack edges. GPR was used to quantitatively map the depth to a subsurface ice layer. Based on the data collected, we were able to determine that the average depth to the top of the ice layer is approximately 1 m.

At another location, Site B, the gently sloping northwest crater wall below the crater rim was observed during the crew mission to be composed of unconsolidated carbonate rubble. Robotic follow-up at

Site B focused on addressing the origin of this carbonate rubble zone and of the local topographic highs within it. Data collected by K10 were used to evaluate four hypotheses, none of which were mutually exclusive. Imagery acquired by K10 supports a preliminary interpretation that the crater wall, though highly degraded, preserves evidence of fault-bounded terraces formed after impact as the crater rim collapsed inward. The images also show that the crater wall is also the site of at least one breccia block that is likely impact ejecta. However, the origin of this block remains unclear, even with the robotic follow-up data.

At Site B, we also used K10 to study the gullies along the northwest crater wall. Terrain images revealed thermally derived, poorly sorted angular rocks ranging from a few cm to 5 mm in size. Panoramic images showed signs of additional polygonal features in the soil. The random shape, size, and orientation of the polygons are consistent with a freeze-thaw process.

Overall, the results from this experiment indicate that robotic follow-up has significant potential for improving human planetary exploration. Specifically, it appears that robotic follow-up is well suited to: (1) testing hypotheses generated during time-limited human fieldwork and subsequent analysis; (2) refining and augmenting data gathered during crew traverses and EVAs; (3) acquiring quantitative instrument data collection.

## V. DISCUSSION

Robotic recon, support and follow-up have many benefits over tightly coupled human-robotic cooperation. Specifically, the independent (but coordinated) use of robotics can improve human exploration in several important ways:

*Facilitates appropriate human-robot interaction (HRI) for space exploration.* Achieving fluid HRI with pacing comparable to human-human interaction speed and efficiency is still many years away. Thus, it is critical to avoid making astronauts wait for a robot. Commenting on robotic recon, Astronaut Harrison Schmitt told us “I am still a skeptic on real-time integration of crewed EVA and robotic activity. In terms of efficiency, it is distracting, to both. Separating them, so that robotic activity supports EVA planning process, makes sense. Real time interaction does not.”

*Can happen at a slower pace.* Until humans have established a permanent (or at least long-duration) presence on a planetary surface, there will always be limited time during human exploration missions for EVA work and robots will not be used if operational pacing is slow. However, significant time is (almost always) available prior to, and following, human missions for robotic operations. Thus, robots can be used to perform recon and follow-up work even if these systems cannot be operated quickly.

*Does not need to determine everything.* Robotic recon is not the same as robotic exploration. Whereas the Mars

rovers are primary science tools (i.e., used to acquire source measurements), the purpose of recon is to evaluate targets, stations, or sites, for subsequent EVA observations and sampling. Robotic recon does not, therefore, need to maximize science return by itself. Instead, recon can focus on preliminary assessment.

*Does not need to make all the measurements.* Robotic recon, support, and follow-up can provide valuable data even with a limited instrument suite. This minimizes mass, power, cost, and operational requirements. Moreover, the robot also does not need to do all tasks. Humans can sample more intelligently than a robot, given the same information, but a robot can provide significant data to improve the planning and execution of EVA fieldwork.

*Supplements and complements crew surface activity and remote sensing.* EVA, while much higher in terms of intellectual resolution, is limited in duration due to the high risk and limited consumables required for life support. Remote sensing is fundamentally limited in resolution, viewpoint, and measurement types. Surface based telerobotic missions can provide ground truth for those things that are visible in remote sensing, and make up for many of the gaps that remain from orbital data or from human EVAs.

*Increases productivity.* Robotics can improve astronaut productivity by improving fieldwork planning, off-loading routine (or repetitive) tasks from humans to robots, and increasing efficiency of planetary surface operations. Sample collection, for example, can be improved by using robotic recon to identify and prioritize targets, by using robotic support to make real-time assessments during sampling operations, and by using robotic follow-up to acquire additional site context (or materials) after primary sampling.

## VI. CONCLUSION

Human-robotic partnership should not be limited to the traditional model of side-by-side, or closely coupled “robot as astronaut tool” use. As advanced as robots have become, they are still slow compared to humans. Concurrent, interdependent operations risk creating situations where the human waits for the robot while it is executing. Robots that cause humans to waste precious resources such as time or life support consumables risk making human missions less productive rather than more. An alternative approach is to separate human and robotic activities in space, or time, or both but design and coordinate their activities to be complimentary

In particular, future missions to the Moon, Mars, or other destinations should be designed with robots working before, in support, and after humans. Robotic recon, support, and follow-up provide an opportunity for a sequence of visits to a site, with robotic high-grading, followed by intensive and more highly focused sampling and in-situ analysis by humans, and long term presence and detailed analysis and documentation by robots.

## VII. ACKNOWLEDGMENTS

We would like to acknowledge the dedication and tireless effort of the many engineers, researchers, and scientists from the Desert Research and Technology Studies (Desert RATS) and Haughton-Mars Project (HMP) analog mission simulations. We also thank the NASA Lunar Science Institute (NLSI) for their advocacy and unwavering support.

The NASA ESMD Exploration Technology Development (ETD) Program, ESMD Analogs Program, and Moon and Mars Analog Mission Analysis (MMAMA) Program supported this work.

## VIII. REFERENCES

- [1] M. Bualat, A. Abercromby, et al. "Robotic recon for human exploration," in *Analogs for Planetary Exploration*, Special Paper 483, W. Garry and J. Bleacher, Eds., Geologic Society of America, 2011.
- [2] R. Burrige, J. Graham, et al. "Experiments with an EVA assistant robot," Proceedings of the International Symposium on Artificial Intelligence, Robotics, and Automation in Space, 2003.
- [3] M. Deans, T. Fong, et al. "Robotic scouting for human exploration," AIAA-2009-6781, AIAA Space Conference, Pasadena, CA, 2009.
- [4] M. Deans, T. Fong, et al. "Using robots before and after humans to improve space exploration," GLEX-2012.04.1.5x12344, Global Space Exploration Conference, Washington, DC, 2012.
- [5] T. Fong, M. Bualat, et al. "Field testing of utility robots for lunar surface operations," AIAA-2008-7886, AIAA Space Conference, San Diego, CA, 2008.
- [6] T. Fong, A. Abercromby, "Assessment of robotic recon for human exploration of the Moon," *Acta Astronautica* 67 (9-10), 2010.
- [7] T. Fong, M. Bualat, et al. "Robotic follow-up for human exploration," AIAA-2010-8605, AIAA Space Conference, Anaheim, CA, 2010.
- [8] T. Fong, J. Rochlis Zumbado, et al. "Space telerobotics: unique challenges to human-robot collaboration in space," *Reviews of Human Factors and Ergonomics Society* 9, 2014.
- [9] R. Francis, J. Moores, and G. Osinski. "A mission control architecture for joint human and robotic lunar exploration missions, as tested in terrestrial analogue missions," GLEX-2012..04.1.6x12294, Global Space Exploration Conference, Washington, DC, 2012.
- [10] R. Hirsh, J. Graham, J., and J. Rochlis. "Human assistant planetary exploration robots," Proceedings of Earth and Space, 2006.
- [11] K. Hodges and H. Schmitt. "A new paradigm for advanced planetary field geology developed through analog experiments on Earth," in *Analogs for Planetary Exploration*, Special Paper 483, W. Garry and J. Bleacher, Eds., Geologic Society of America, 2011.
- [12] S. Lee, D. Lees, et al. "Reusable science tools for analog exploration: xGDS Web Tools, VERVE, and Gigapan Voyage," *Acta Astronautica*, 2012.
- [13] A. Ross, J. Kosmo, and B. Janoiko, "Historical synopses of Desert RATS 1997-2010 and a preview of Desert RATS 2011," *Acta Astronautica*, 2011.
- [14] K. Shillcutt, R. Burrige, and J. Graham. "Boudreaux the Robot (a.k.a. EVA Robotic Assistant)," Papers from the AAAI Fall Symposium on Human-Robot Interaction, 2002.

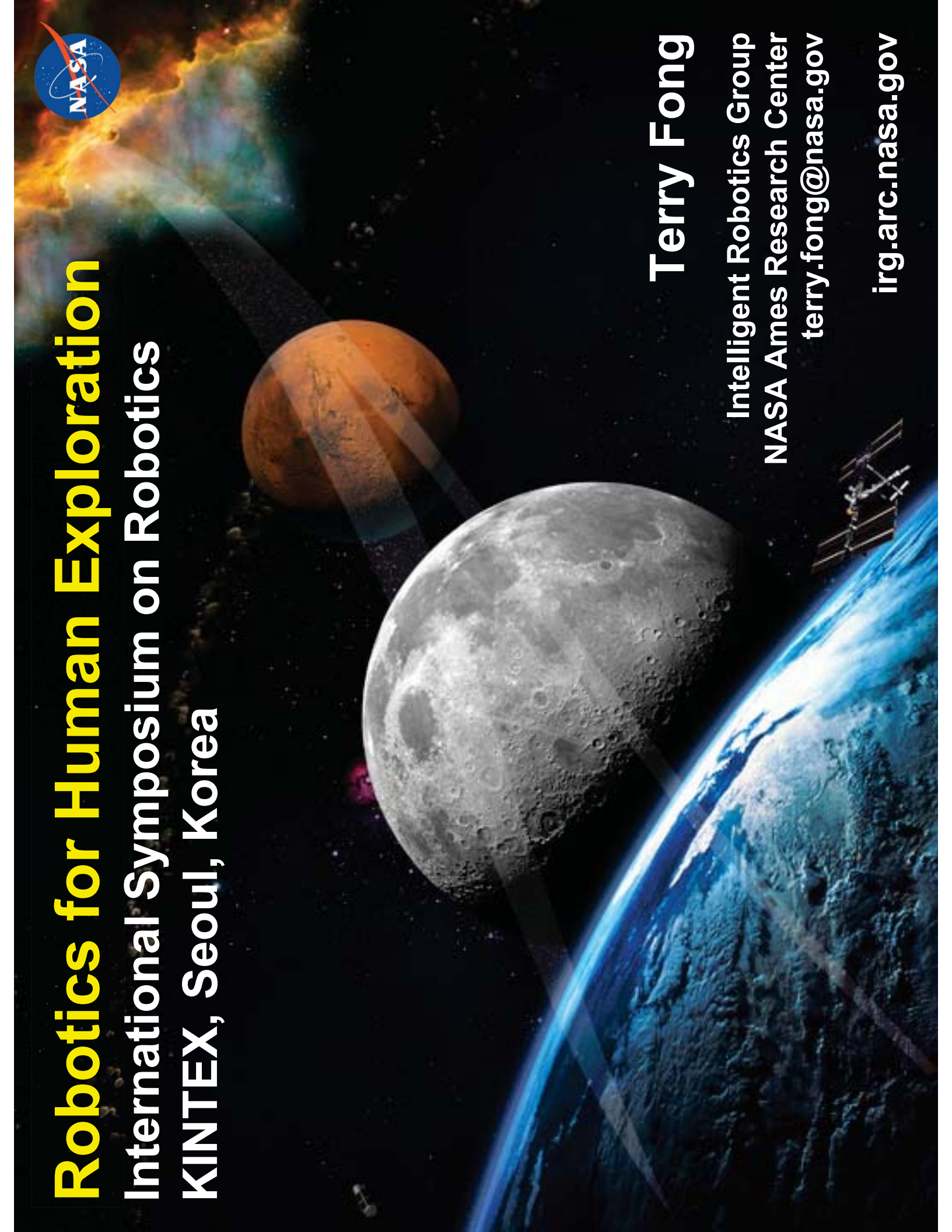
A vertical space-themed background featuring a view of Earth from space at the bottom, the Moon in the center, and Mars in the upper left. A colorful nebula is visible in the top left corner. The text is overlaid on the left side.

# Robotics for Human Exploration

## International Symposium on Robotics KINTEX, Seoul, Korea



**Terry Fong**

Intelligent Robotics Group  
NASA Ames Research Center  
[terry.fong@nasa.gov](mailto:terry.fong@nasa.gov)

[irg.arc.nasa.gov](http://irg.arc.nasa.gov)



# Apollo Surface Operations



Jack Schmitt & Lunar Roving Vehicle  
(Apollo 17)

# What's Changed Since Apollo?



Kaguya

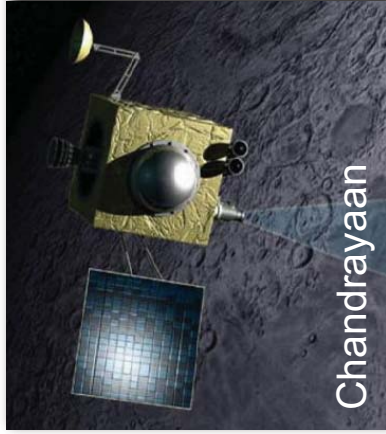

Chandrayaan

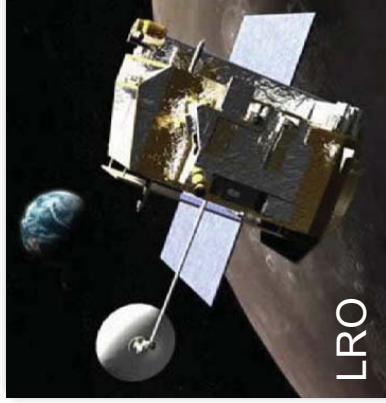

LRO

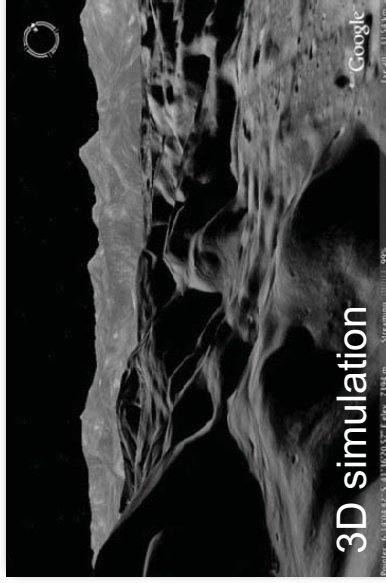

3D simulation



Phoenix



Dante II



Zoë

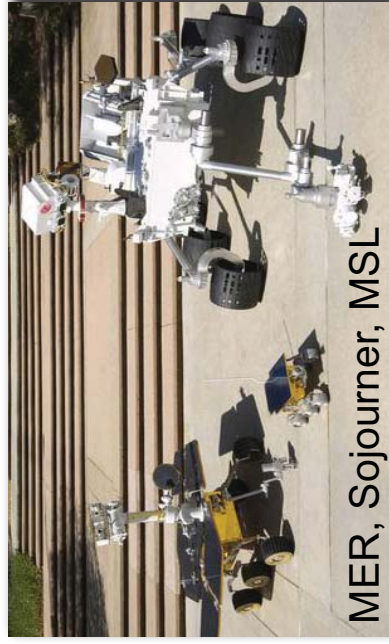

MER, Sojourner, MSL



ATHLETE, K10, Chariot

# Exploration destinations

*(one-way travel times)*

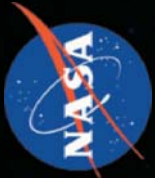

**Future missions will be longer, more complex, & require new technology**



**Robotics and Mobility**



**Deep Space Habitation**



**Advanced Spacesuits**



**Advanced Space Comm**



**Advanced Propulsion**



**Resource Utilization**



**Human-Robot Systems**

# Robotics for Human Exploration

## Purpose

- Increase human productivity
- Improve mission planning & execution
- Transfer some tasks to robots (tedious, repetitive, long-duration)

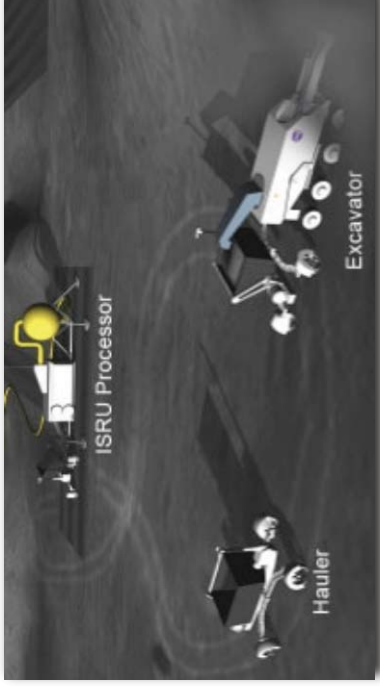

## Before Crew

- Recon (scouting) & prospecting
- Site prep, deploy equipment, etc.



## Supporting Crew

- Inspection, mobile camera, etc.
- Heavy transport & mobility



## After Crew

- Follow-up & close-out work
- Site survey, supplementary tasks, etc.

# 2009 Robotic Recon Experiment

## Objectives

- Test **robotic recon** ahead of crew
- Test **coordinated human-robot** field exploration
- Fold lessons learned into lunar **surface science ops** concepts

## Results

- Captured **requirements** (instruments, comm, nav, etc.) for robotic recon
- **Assessed impact** of robotic recon on traverse planning & crew productivity
- Learned how to improve human **productivity & science return**

*M. Bualat et al. (2011). Robotic recon for human exploration: method, assessment, and lessons learned. GSA Special Paper.*

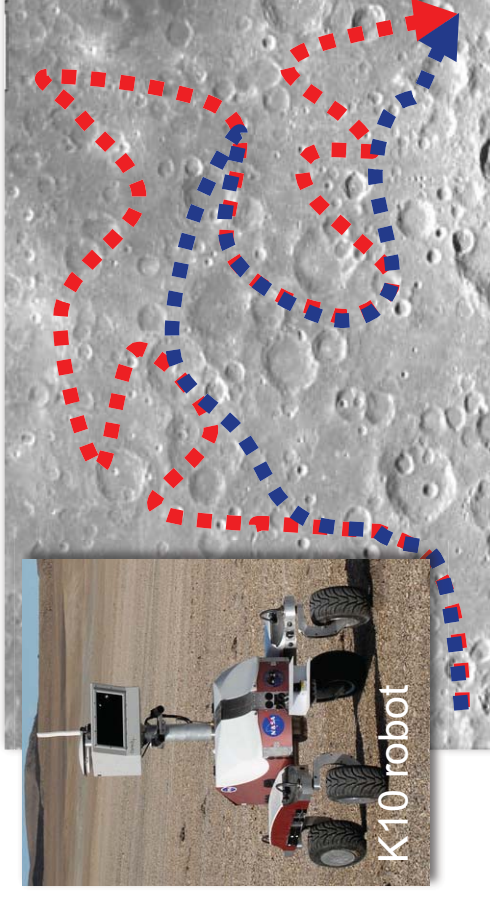

# Why Is Recon Useful?

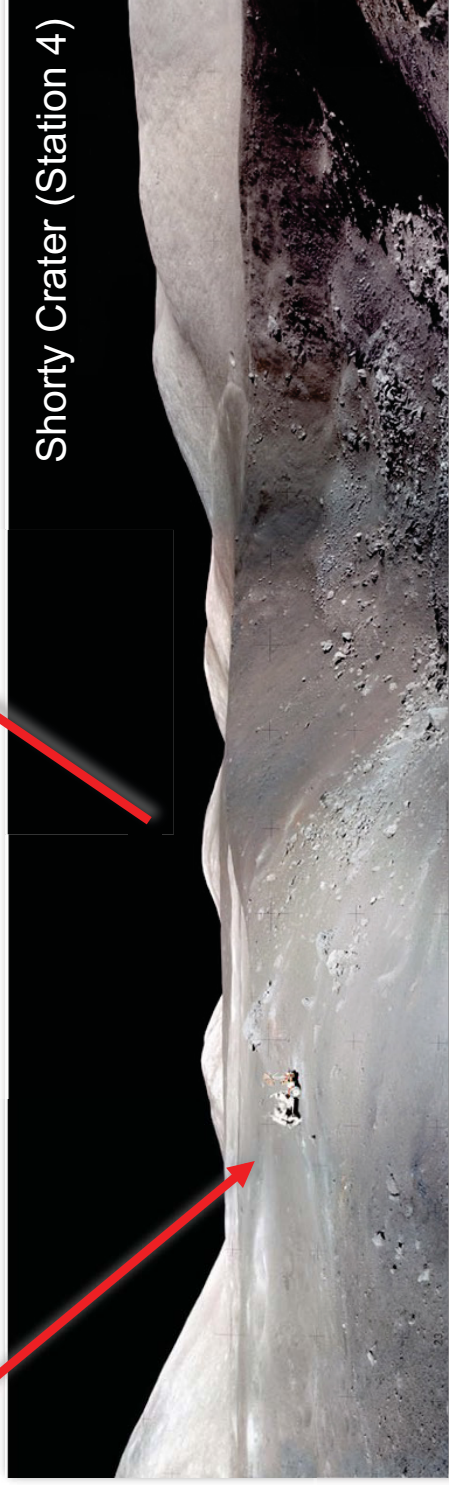
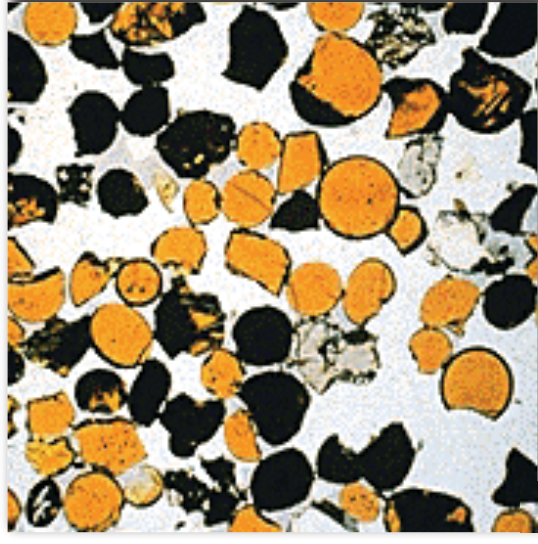
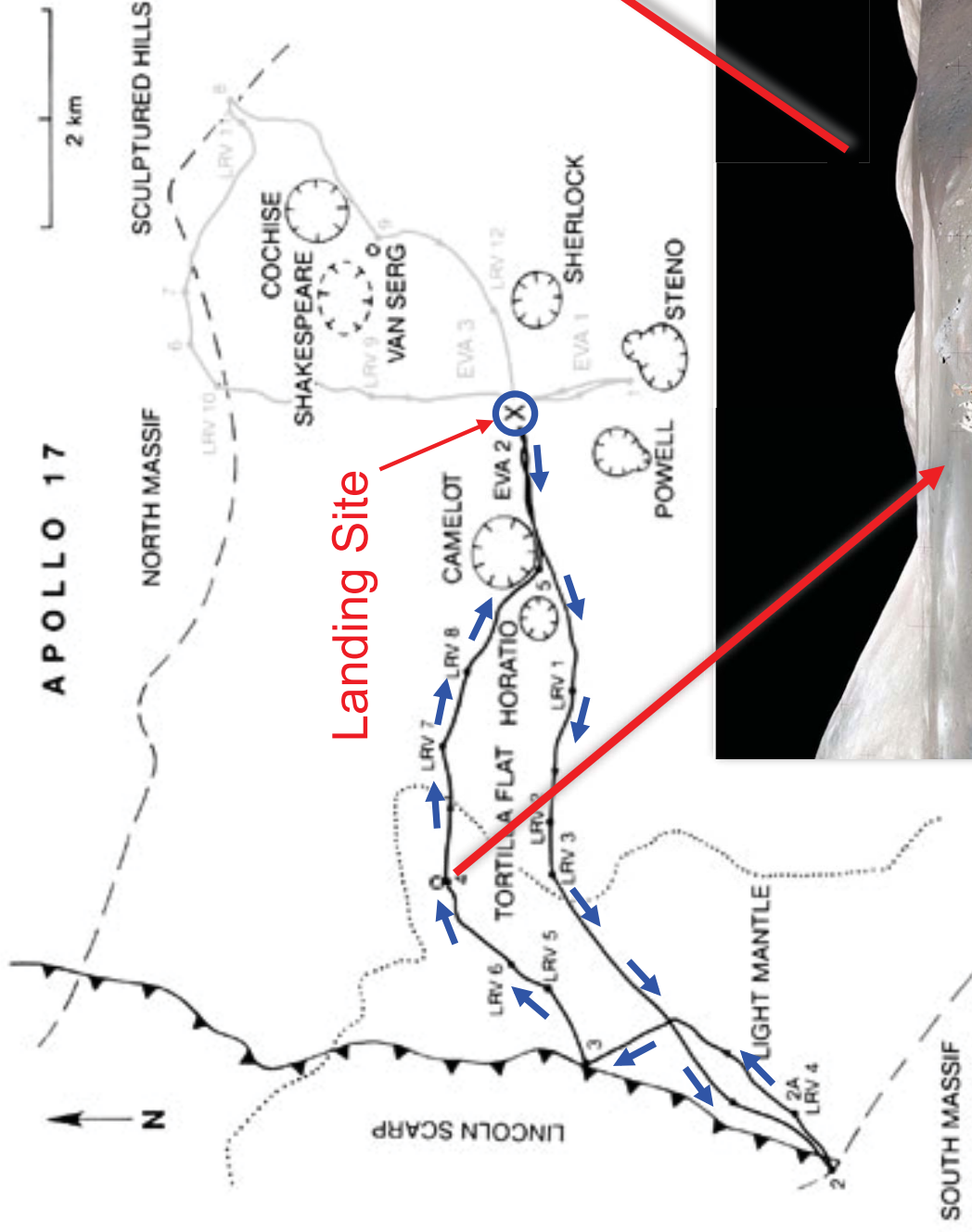

Shorty Crater (Station 4)

# Field Experiment

## Pre-Recon

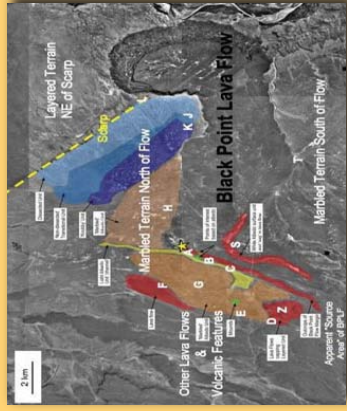

## Robot Mission



## Pre-Crew

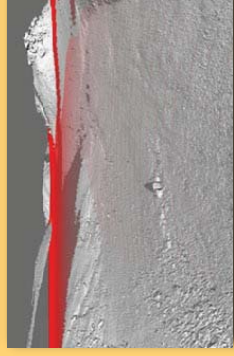

## Crew Mission



**Mar 1 – June 1**

- Satellite images
- Geologic map

**June 14 – 26**

- K10 at BPLF
- Ground control at NASA LSI

**July 1 – Aug 15**

- Recon images
- Terrain models

**Aug 29 – Sep 3**

- LER at BPLF
- Science backroom at BPLF



# Lunar Analog Site

## Black Point Lava Flow (BPLF)

- 65 km N of Flagstaff, AZ
- Analog of the “Straight Wall”  
(Mare Nubrium / Rupes Recta)
- Basaltic volcanic rocks & unit contacts





# Robot Mission (June 2009)

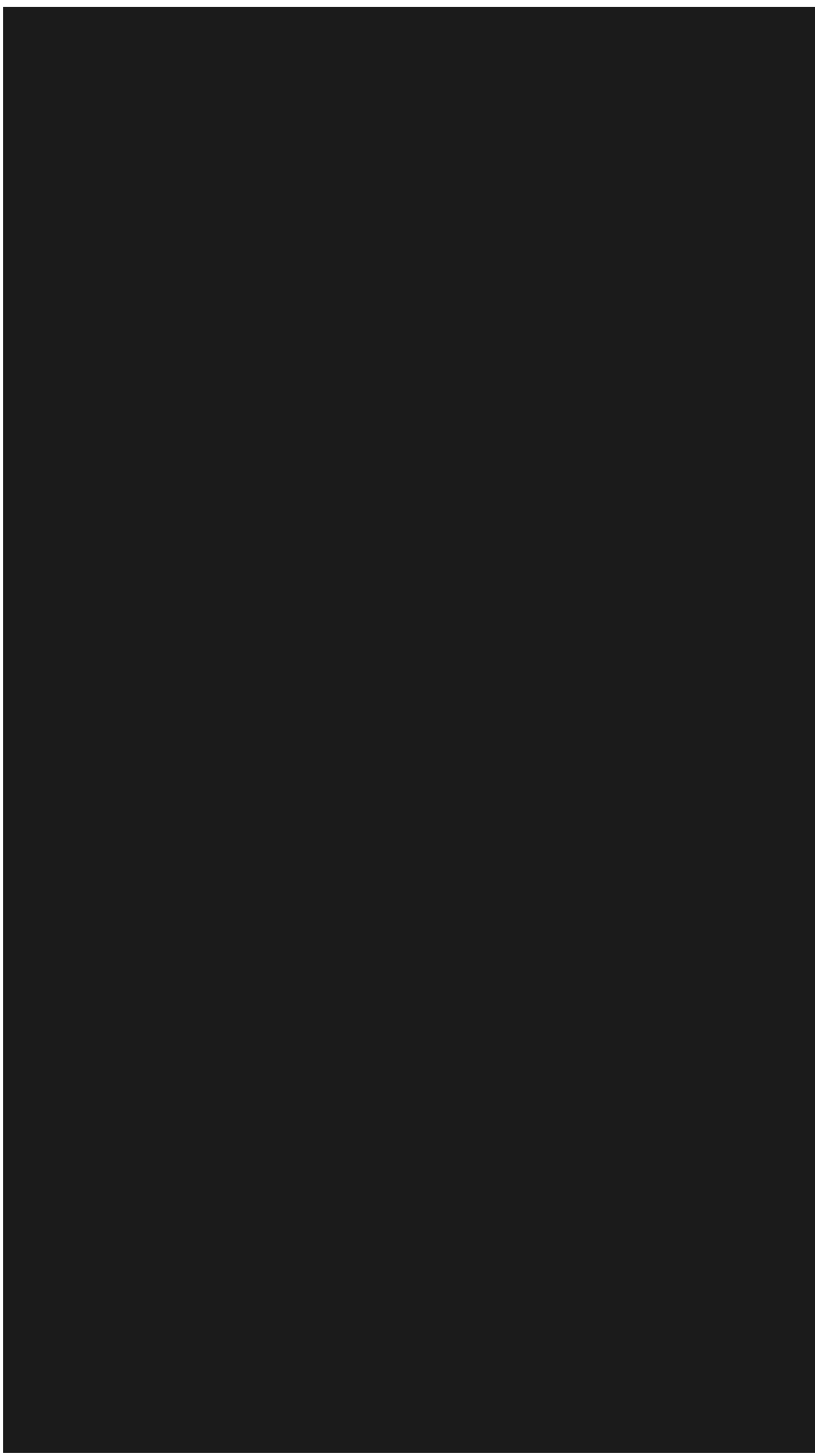

# Collected Recon Data

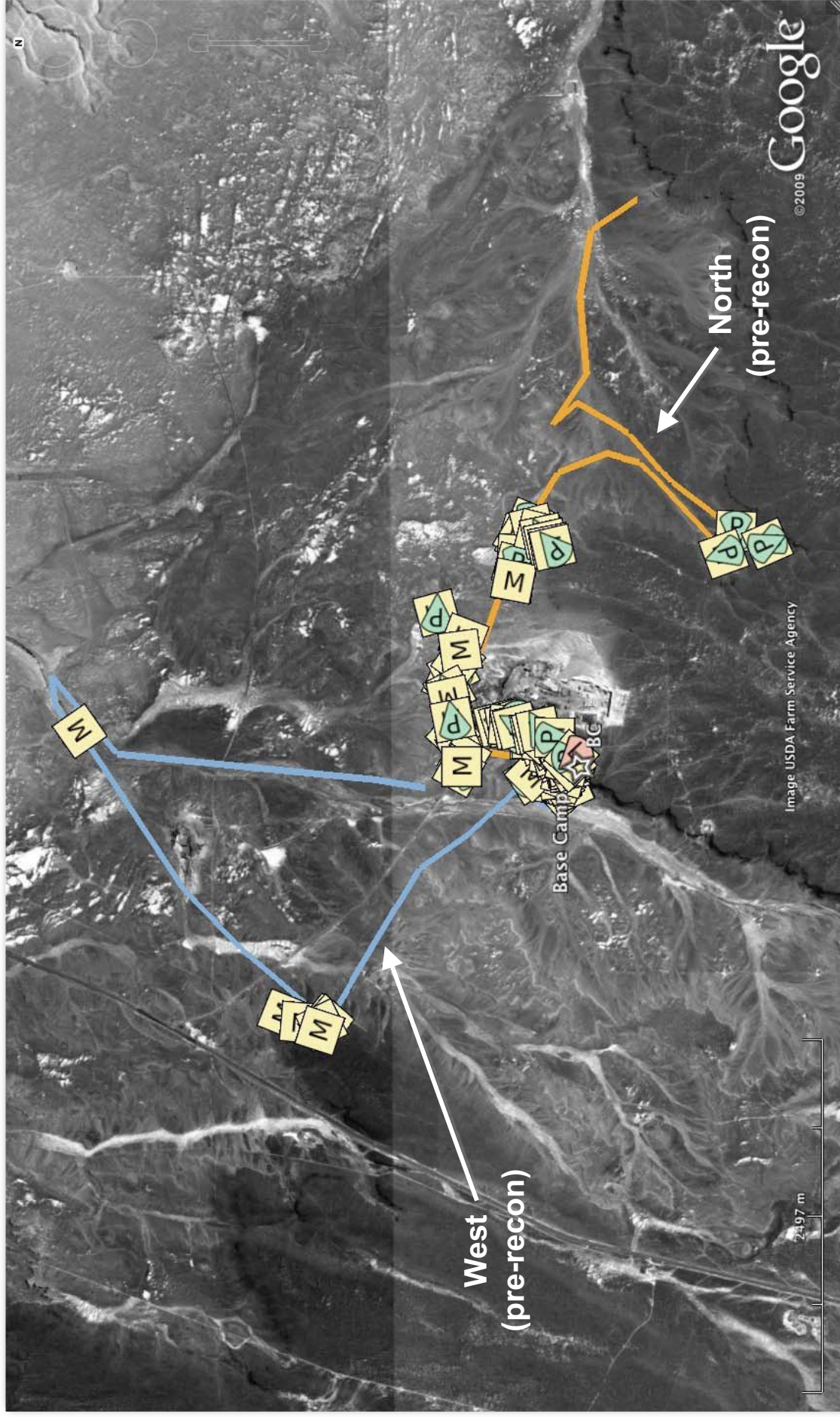

**8.5 GB** data collected (**52 hrs** of robotic recon operations)  
**39** LIDAR scans, **75** GigaPan, and **95** terrain images

# Orbital Data



**Digital Globe QuickBird (60 cm/pixel)**



# Surface Data

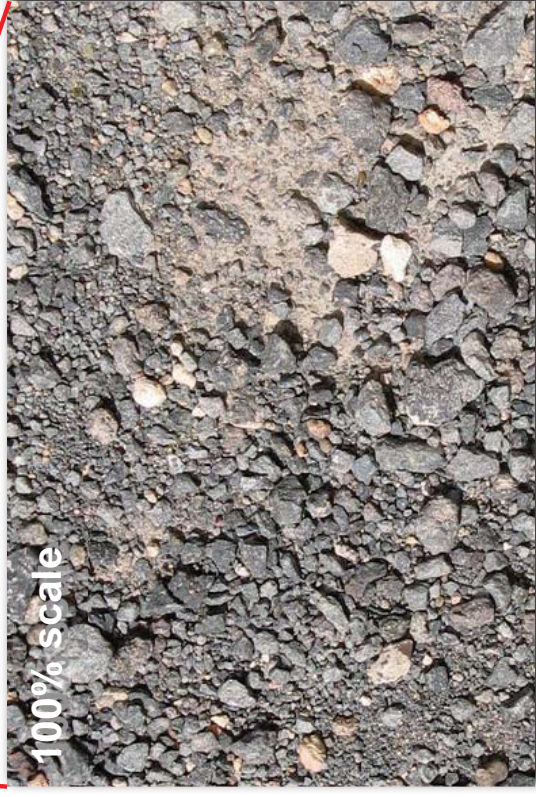

# Surface Data



3D scanning LIDAR (250 m range, 3 mm depth resolution)

# Crew Mission (September 2009)

## Space Exploration Vehicle (SEV)

- Prototype pressurized crew vehicle for lunar operations
- Two “suit ports” for rapid (15 min) egress and ingress
- 20 km/hr max, active suspension
- 3.5 x 5 m (wheelbase x length)

## Crew A

- Mike Gernhardt & Brent Garry
- W1 (pre-recon) + N2 (post-recon) traverses

## Crew B

- Andy Thomas & Jake Bleacher
- N1 (pre-recon) + W2 (post-recon) traverses



Space Exploration Vehicle



# Crew Mission (September 2009)



# Robotic Recon Results

## “West” region

- **Pre-recon** plan was designed to be **Apollo-like**
  - Rapid area coverage (visit 5 geologic units)
  - Single visit
- **Post-recon** plan is **significantly** different
  - More flexible & adaptable
  - Recon data supports **real-time** replanning
- **Impact** of recon
  - **Reduced** science uncertainty
  - **Improved** target prioritization

*T. Fong et al. (2010). Assessment of robotic recon for human exploration of the Moon. Acta Astronautica 67 (9-10)*

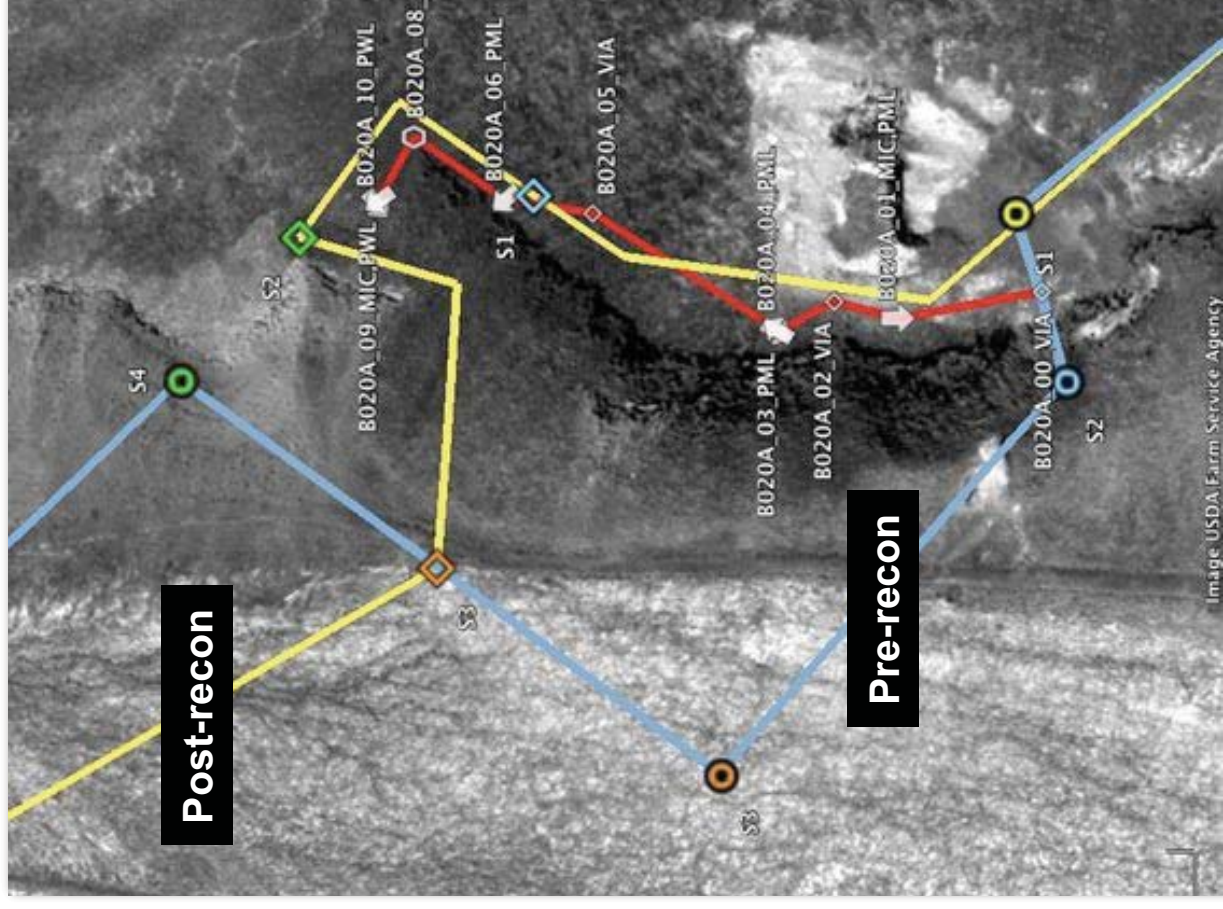



# Robotic Follow-up Experiment

## An exploration problem

- Never enough time for field work
- “If only I could have...”
  - More observations
  - Additional sampling
  - Complementary & supplementary work

## The solution

- Use robots to “follow-up” after humans
- Augment human field work with subsequent robot activity
- Use robots for work that is tedious or unproductive for humans to do

*M. Deans et al. (2011). Field testing robotic follow-up for exploration field work. Proc. of the Lunar & Planetary Science Conf.*



# Why is Follow-up Useful?

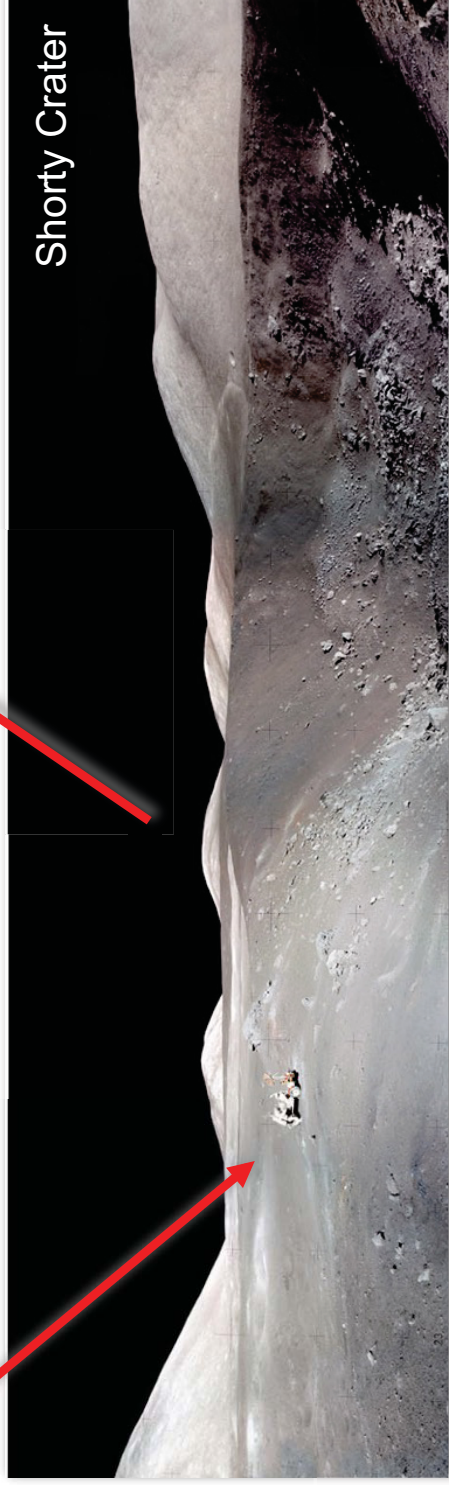
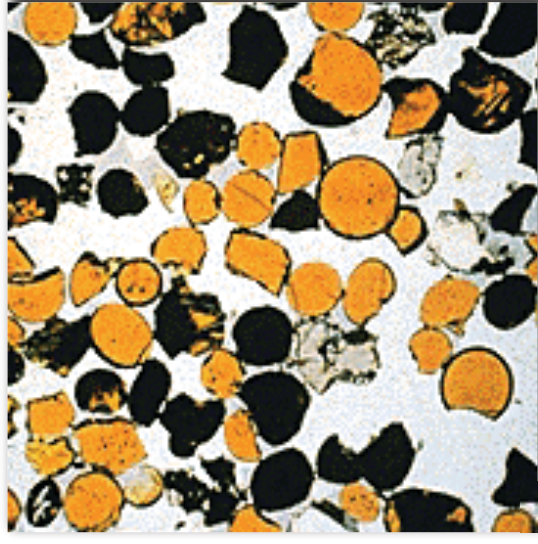

# Lunar Analog Site

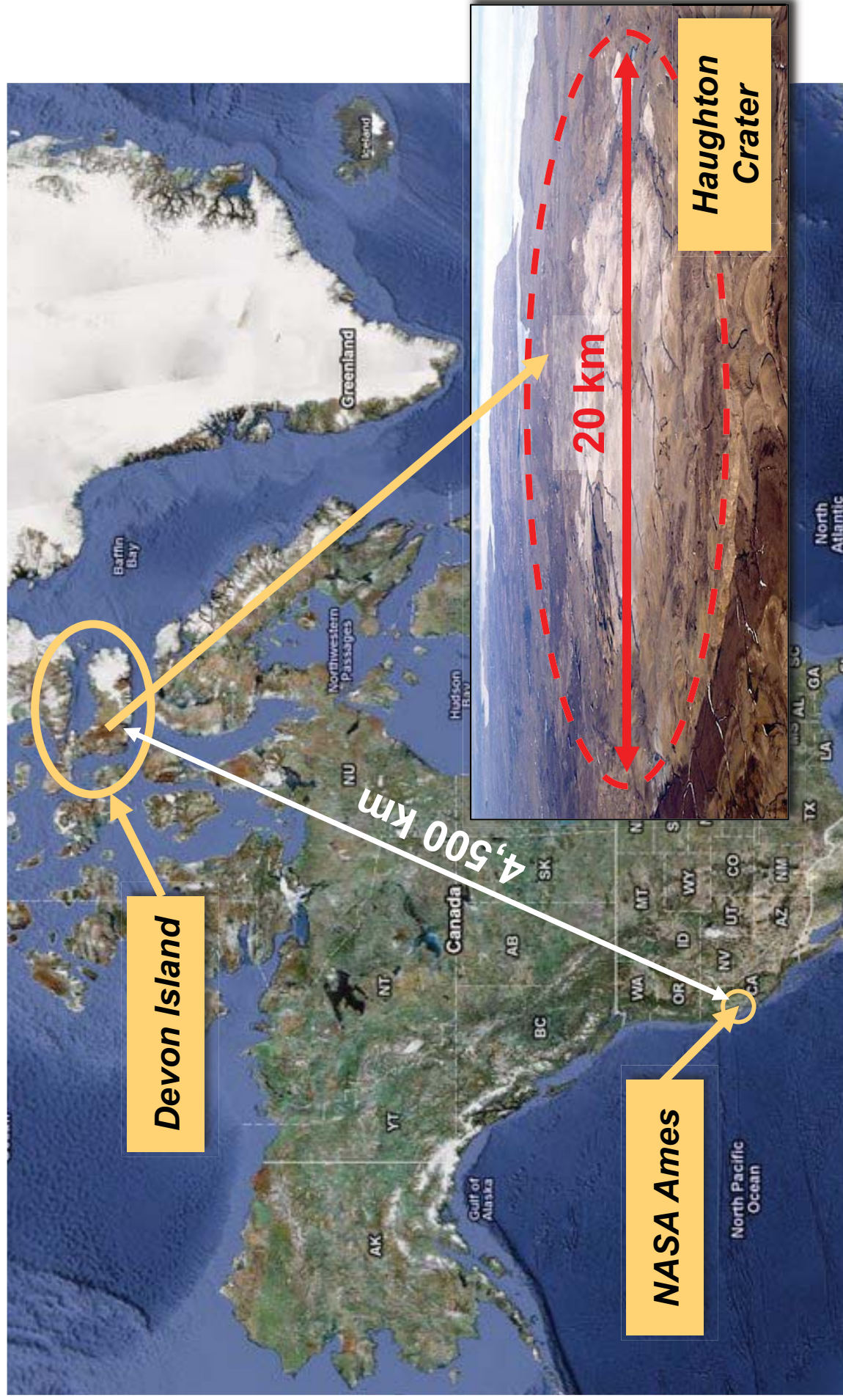

# Haughton Crater

**Shackleton Crater at the South Pole of the Moon** is 19 km in diameter and might present H<sub>2</sub>O ice in surrounding shadowed zones. It is a prime candidate site for human exploration. Haughton Crater, also ~ 20 km in size, is by far the best preserved impact structure of its class on Earth and is located in a H<sub>2</sub>O ground ice-rich rocky desert. Haughton Crater is an excellent **scientific and operational analog for lunar craters such as Shackleton**.

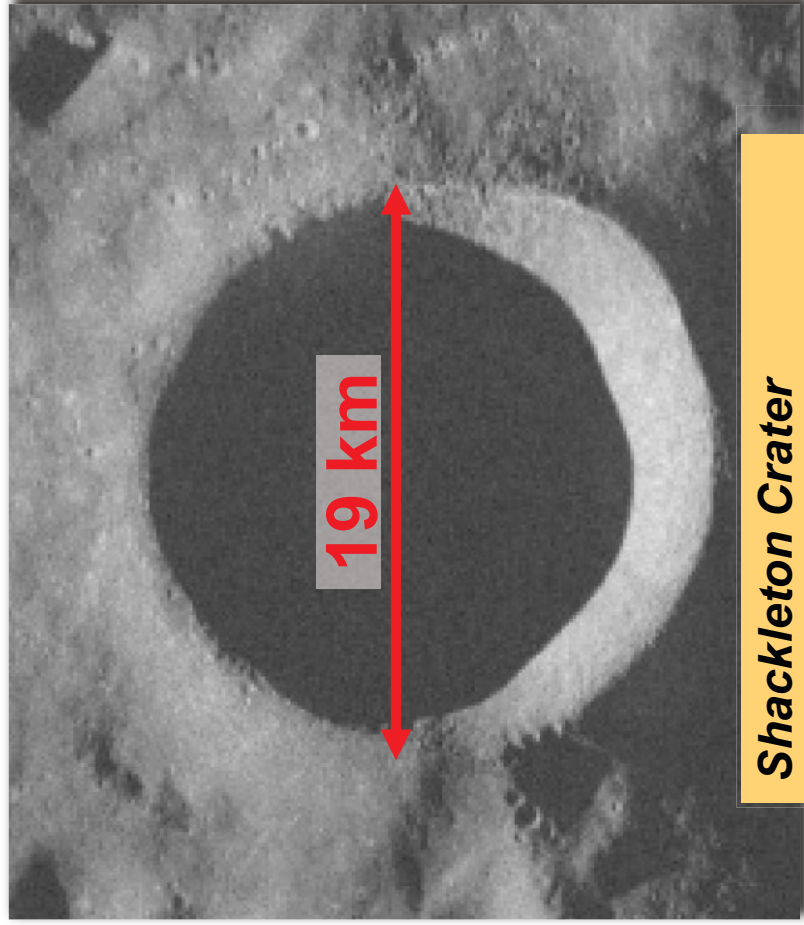

**Shackleton Crater**  
(lunar South Pole)  
2005 Arecibo radar image

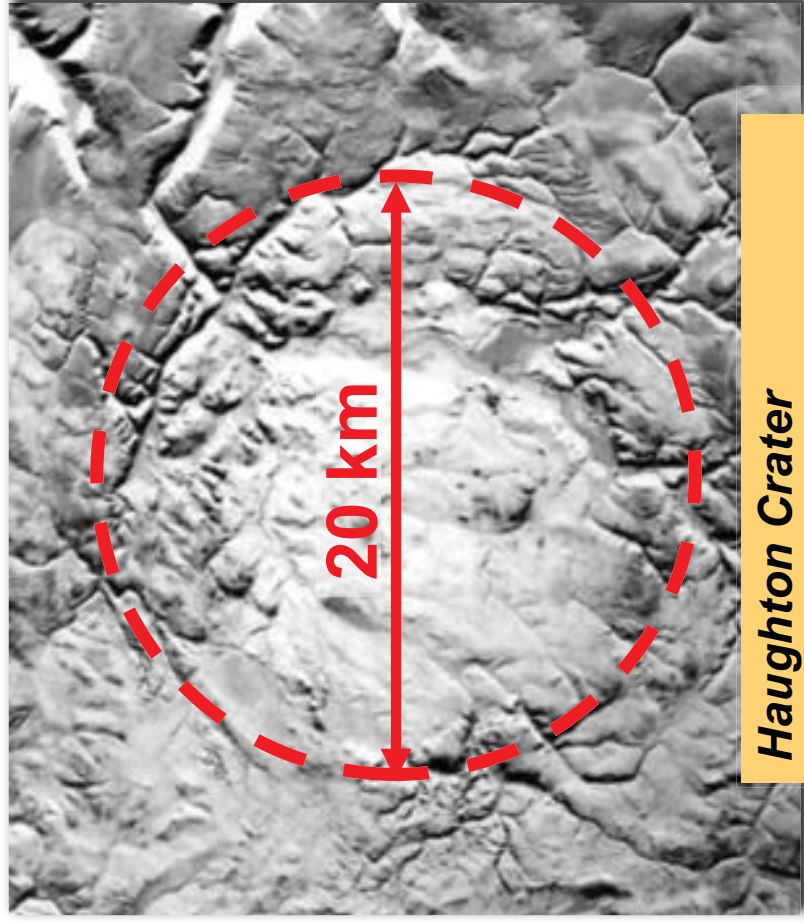

**Haughton Crater**  
(Devon Island, Canada)  
radar image

# Crew Mission (July 2009)



Mark Helper  
and Pascal Lee



Essam Heggy  
and Pascal Lee

## Geologic Mapping

- Document geologic history, structural geometry & major units
- Example impact breccia & clasts
- Take photos & collect samples

## Geophysical Survey

- Examine subsurface structure
- 3D distribution of buried ground ice in permafrost layer
- Ground-penetrating radar: manual deployment, 400/900 MHz

# Geologic Mapping

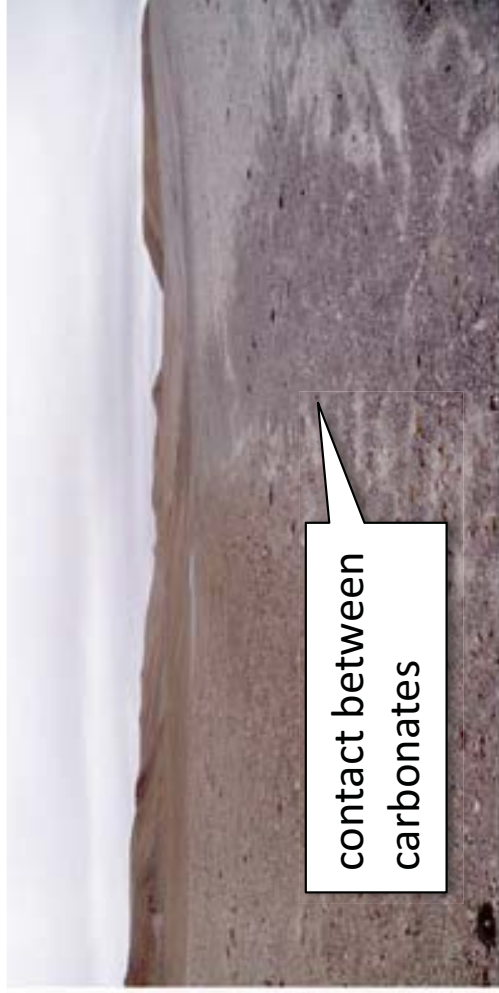

# Geophysical Survey

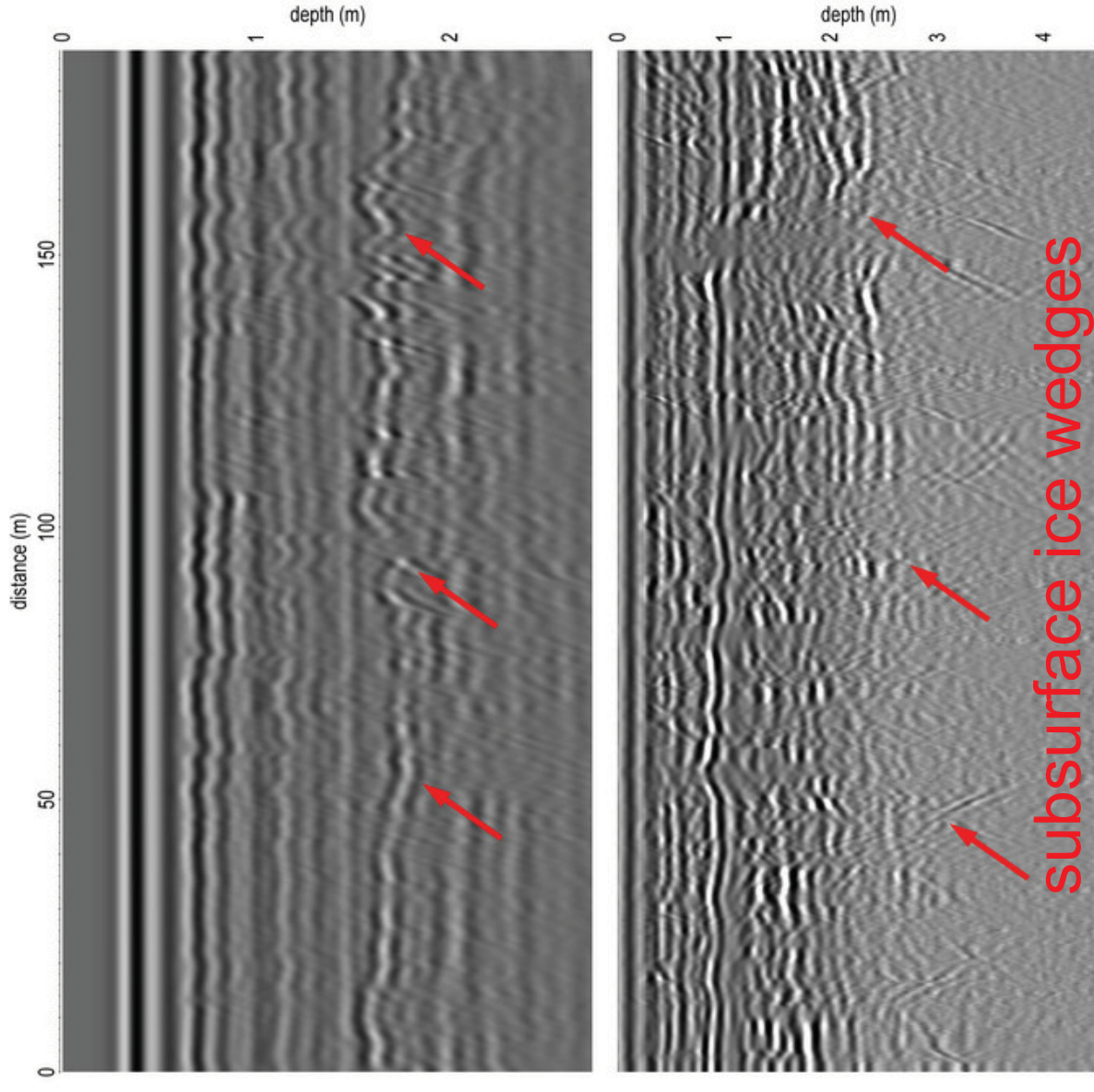

# Robotic Follow-up Plan





# Robot Mission (July 2010)



# Robotic Follow-up Results

## Geologic Mapping

- **Verified** & **amended** the geologic map in multiple locations
- In some places, robot data was ambiguous, or lacked sufficient detail to re-interpret the map

## Geophysical Survey

- **Correlated** surface & subsurface features of “polygons”
- **Determined** average depth of buried ice layer

*T. Fong et al. (2010). Robotic follow-up for human exploration. AIAA-2010-8605. Proc. of AIAA Space 2010.*

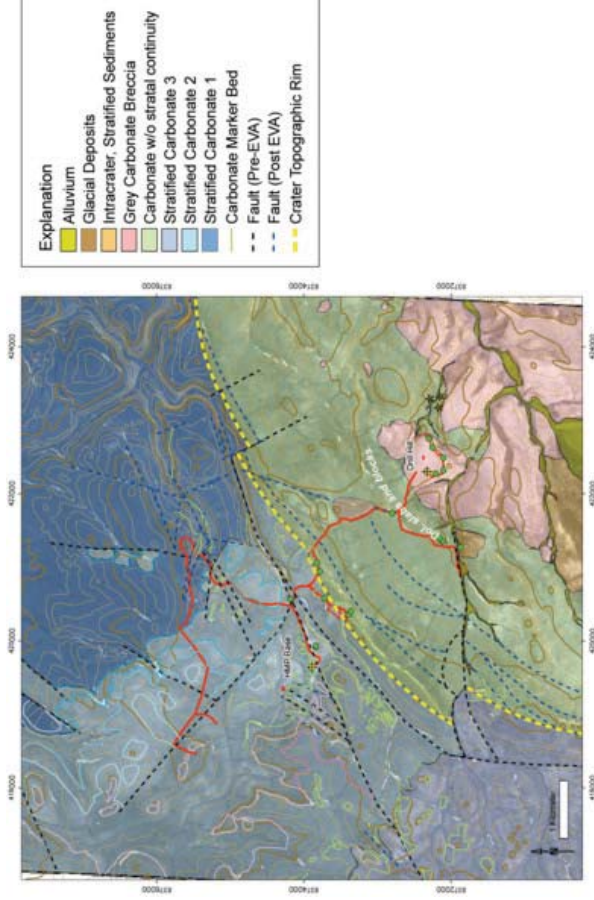

# Human Exploration Telerobotics

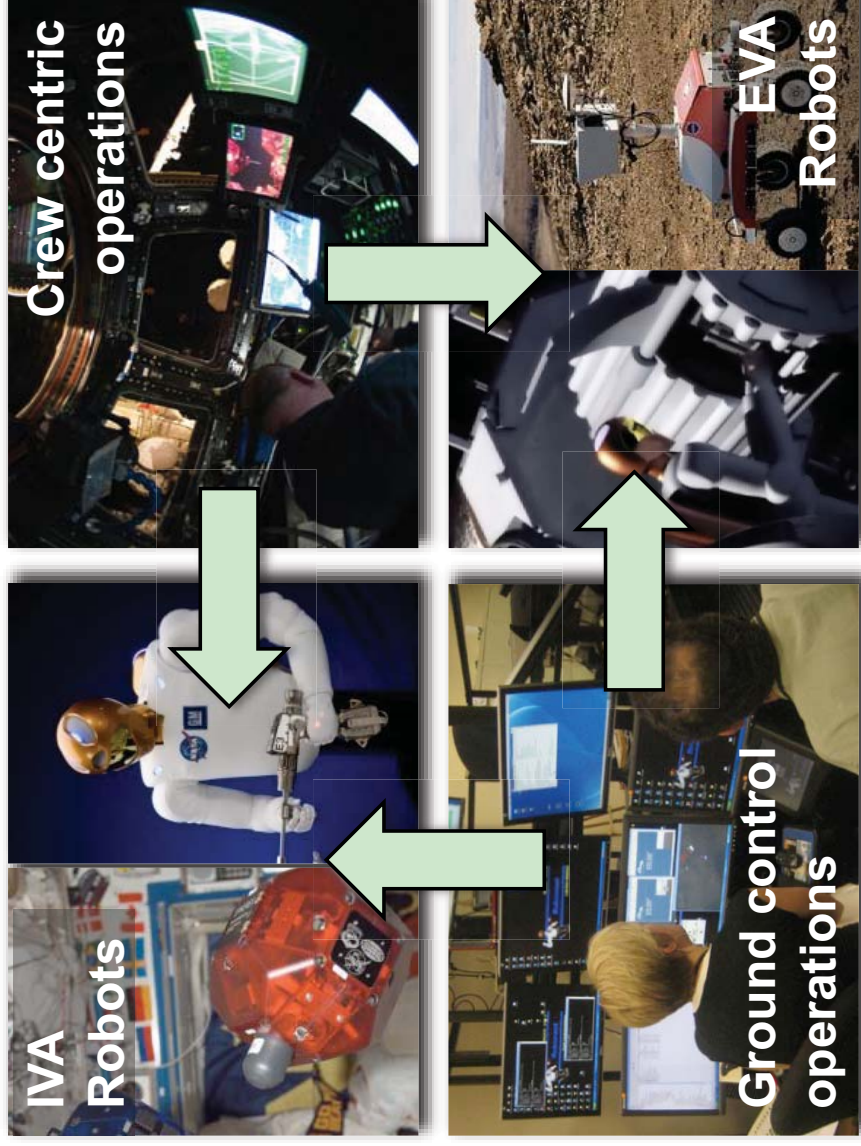

## Ground control ops

- Ground operates robot on flight vehicle
- **Off-load routine & tedious work** from crew to ground control
- Routine maintenance, inventory, etc

## Crew centric ops

- Astronauts remotely operate robots
- **Extra-vehicular activities** (outside vehicle, on surface, etc.)
- Inspection, surface field work, etc.

# Robonaut 2

## Dexterous humanoid robot

- Capable tool to support crew
- Share human tools & workspaces
- Increase IVA and EVA efficiency
  - Worksite setup & tear-down
  - Routine maintenance
  - Robotic assistant
  - Contingency tasks
- Human-scale
  - 10 kg lift capability
  - 80 cm wide
- Human-safe
  - Force limiting controller
  - Series-elastic actuators
  - Multi-level sensing

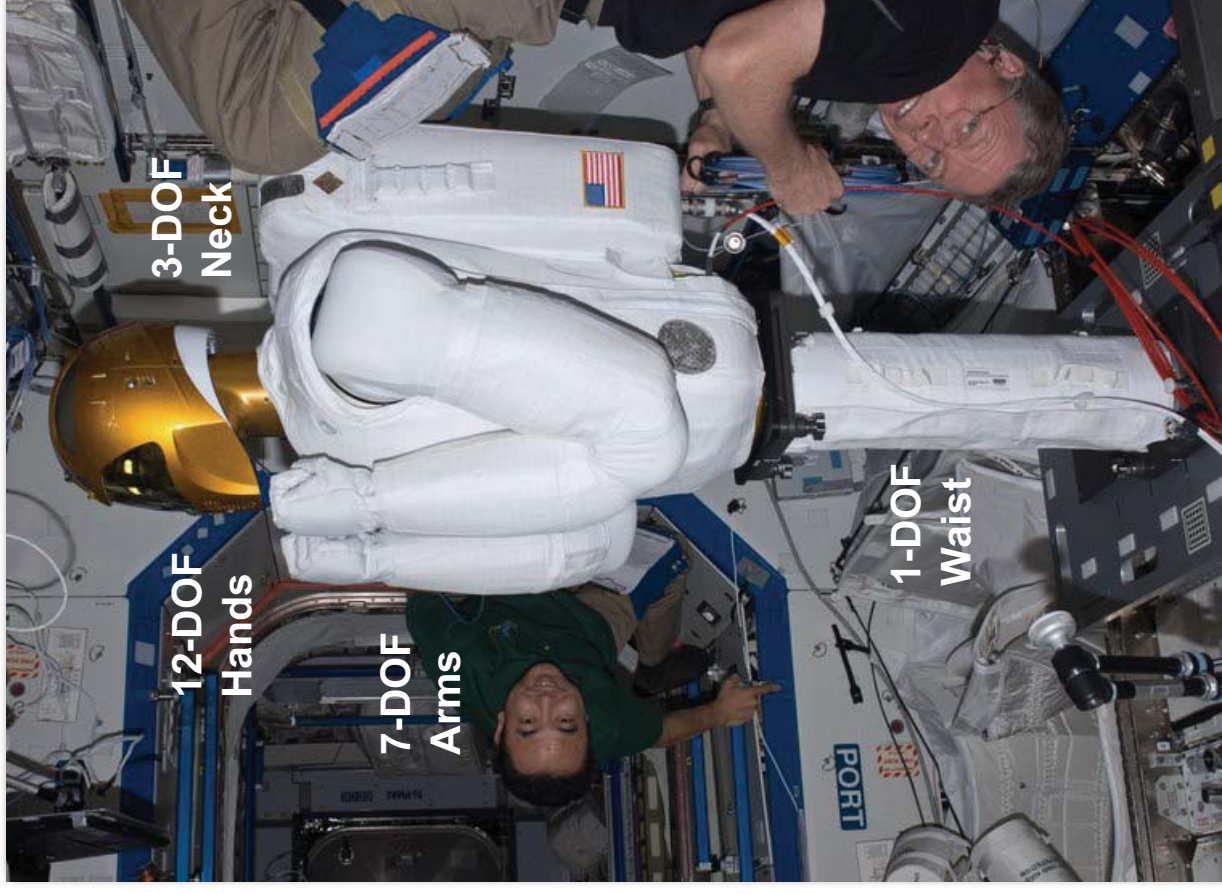

# Robonaut 2



# Robonaut 2 – Ground Control Ops

## 2012 Accomplishments

- Oct 13 First free space arm motion
- Feb 14 Full system checkout (42-DOF)
- Mar 14 Handheld air flow meter work
- June 27 Dexterous manipulation of IVA interfaces
- Aug 23 Dexterous manipulation of power switch and key pad panel
- Aug 27 Dexterous manipulation of EVA interfaces including hand rail cleaning

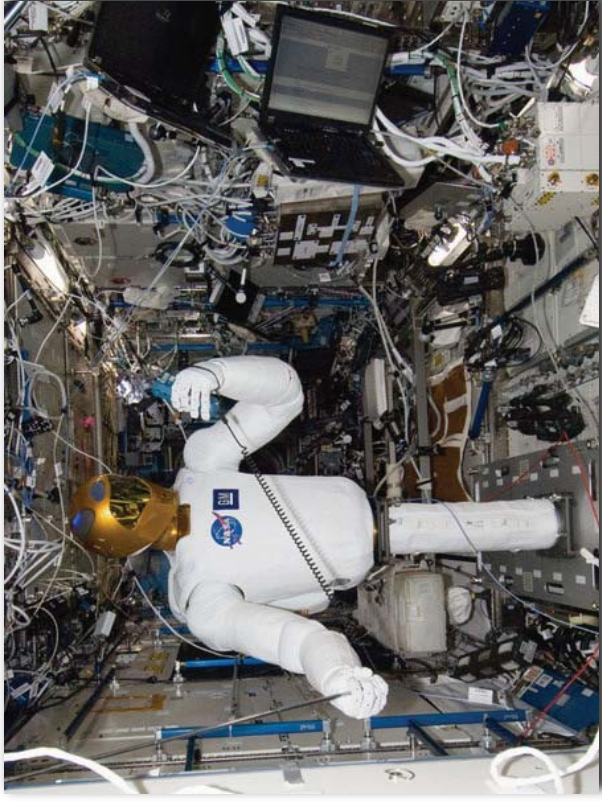

R2 using Velocicalc air flow meter

## Key Points

- Robonaut 2 demonstrates operational capabilities for:
  - Manipulating **panel switches & dials**
  - Working **IVA & EVA interfaces**
  - Handling **soft goods**
  - Performing **air sampling** with Velocicalc meter
  - Performing IVA **hand rail cleaning**



Robonaut 2 cleaning hand rail

# Handrail Cleaning

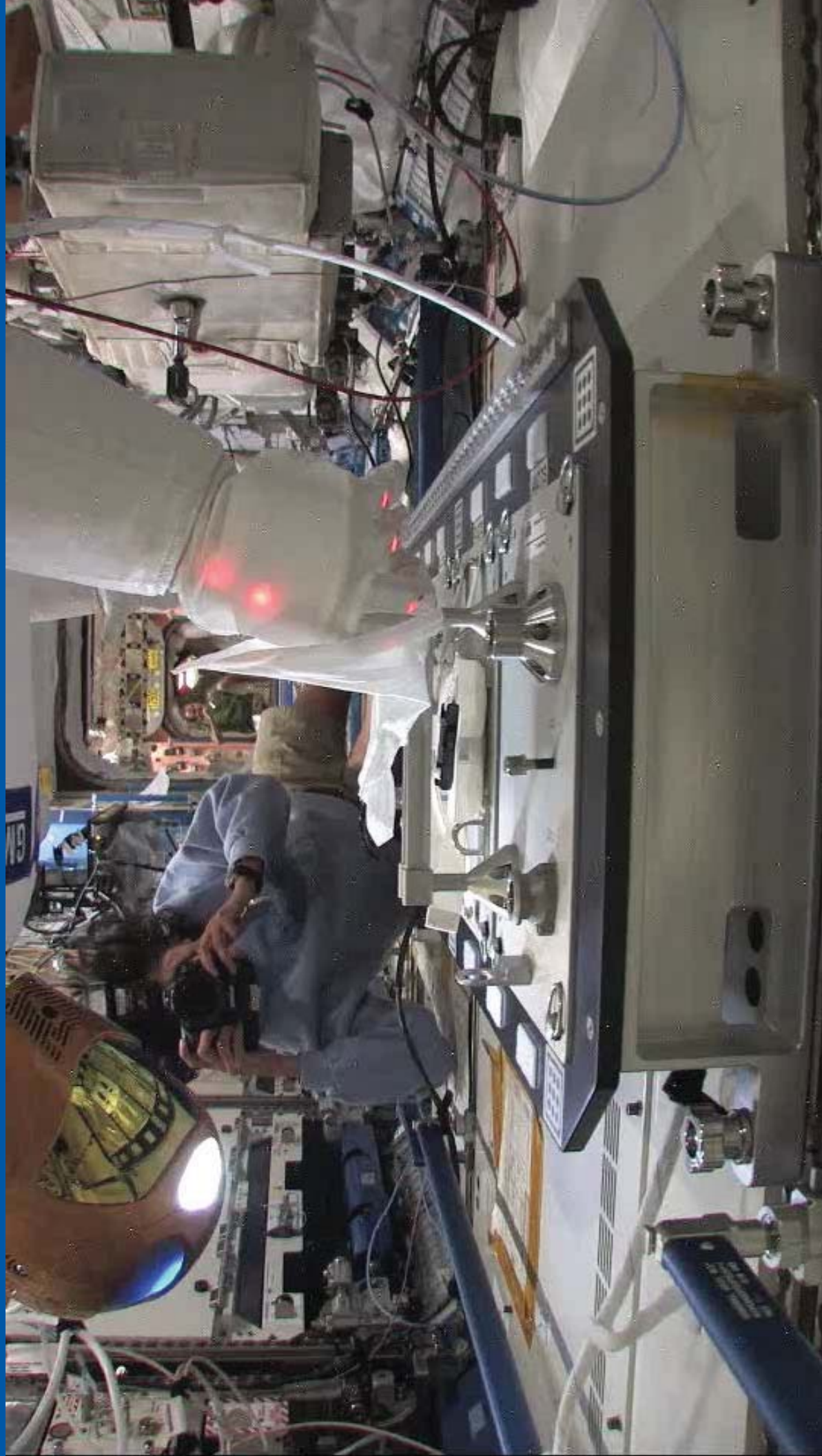

# Smart SPHERES

## Synchronized Position Hold Engage Reorient Experimental Satellites (SPHERES)

- Developed by MIT Space Systems
  - 22 cm diameter, 4 kg
  - Cold-gas propulsion (CO<sub>2</sub>)
  - External sonar beacon localization
- Testbed for distributed satellite & free-flying control algorithms

## Smart SPHERES

- Smartphone upgrade
- Converts SPHERES into a telerobot
- Remotely operated by Space Station mission control (Houston)





# Smartphone Upgrade

## Samsung Nexus S

- Android-OS smartphone
- 1GHz Cortex A8 (ARM) + GPU, 512 MB RAM, 16 GB flash
- 3-axis gyro, 3-axis accel., two color cameras (still/video)
- 802.11 b/g/n (Wi-Fi)
- 63x124x11 mm, 129 g



## Key Points

- First **off-the-shelf** smartphone certified for the Space Station
- Provides fast CPU/GPU, wireless networking, sensors, & touchscreen
- Launched to the Space Station on the last Shuttle flight (STS-135)



# Putting a Smartphone on ISS ...

## Modifications for ISS Certification

- Replaced Lithium polymer battery with Alkaline (AA “six-pack”)
- Removed GSM chip (transmitter front-end module)
- Added teflon tape to contain glass in case of breakage

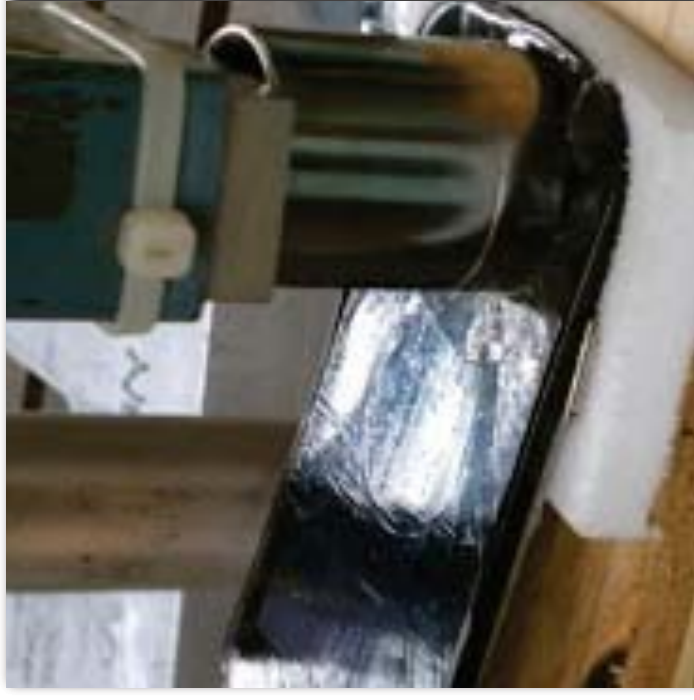
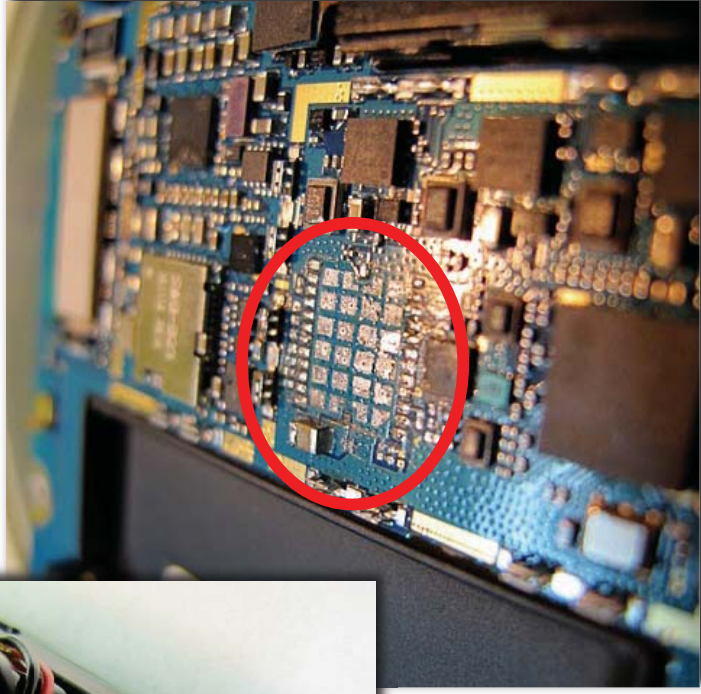

# Smartphone Checkout



**November 1, 2011**

**Crew: Mike Fossum, Expedition 29 Commander**

**4x speed**

# Smart SPHERES – Ground Control Ops

## Space Station Free-Flying Survey (December 2012)

- Demonstrate video survey within ISS (Kibo Laboratory module)
- Smart SPHERES remotely operated by ground controller
- Waypoint-based command sequences

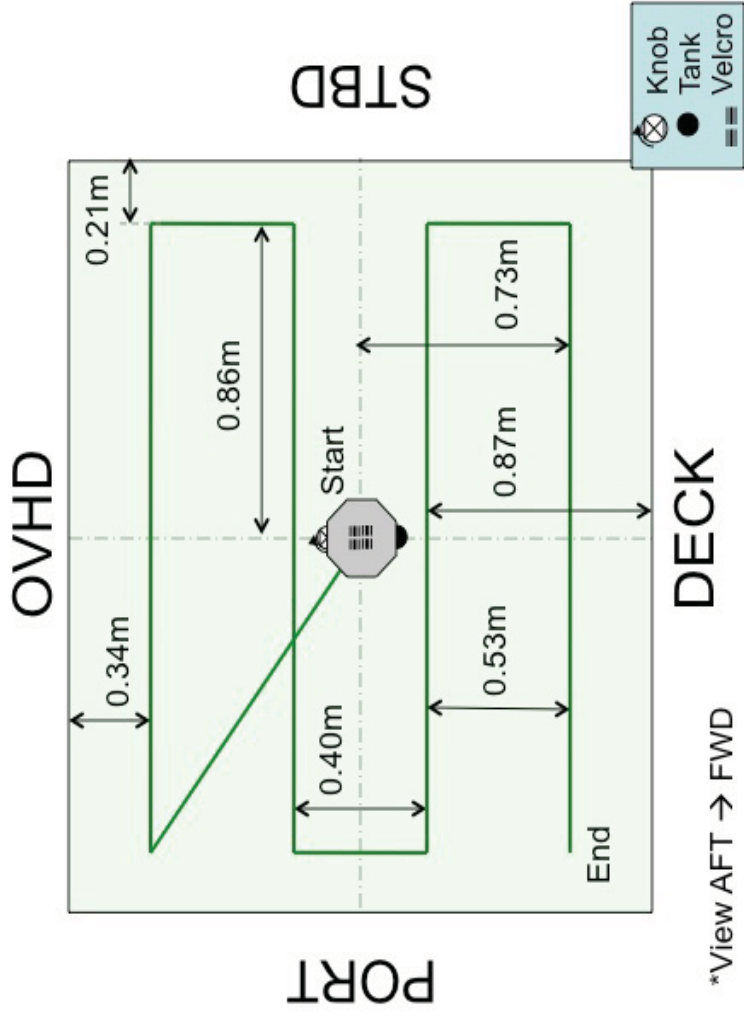

# Free-Flying ISS Survey



December 12, 2012  
Crew: Kevin Ford, Expedition 33 Commander

2x speed



# Conclusion

## Human-robotic partnership

- Traditional “robot as tool” model is not always effective
- Concurrent, interdependent operations can be inefficient
- Better to design activities to be complementary, but perhaps separated in space and time

## Future space exploration will involve...

- Robots working **before** humans
- Robots **supporting** humans
- Robots working **after** humans



# Questions ?

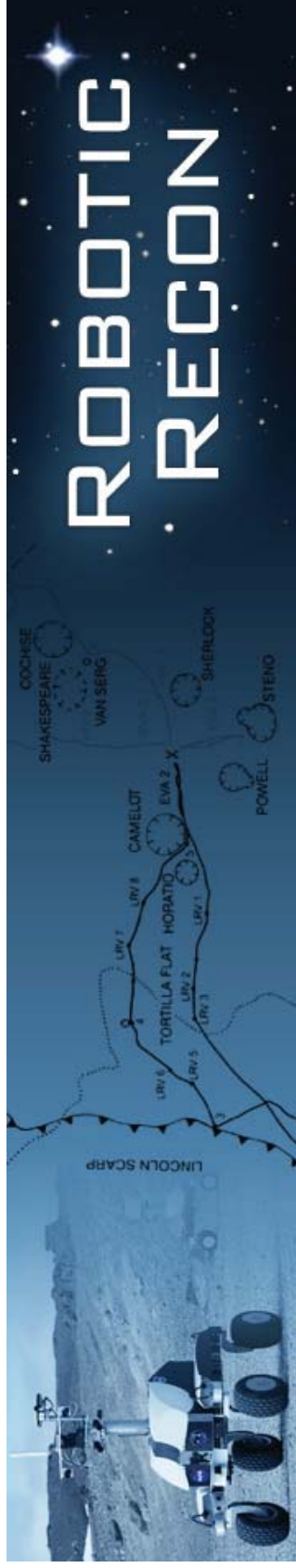

[www.nasa.gov/telerobotics](http://www.nasa.gov/telerobotics)

