

NASA Fixed Wing Project Propulsion Research and Technology Development Activities to Reduce Thrust Specific Energy Consumption

Michael D. Hathaway¹ and Ruben Del Rosario²
NASA Glenn Research Center, Cleveland, OH, 44135

and

Nateri K. Madavan³
NASA Ames Research Center, Moffett Field, CA, 94035

This paper presents an overview of the propulsion research and technology portfolio of NASA Fundamental Aeronautics Program Fixed Wing Project. The research is aimed at significantly reducing the thrust specific fuel/energy consumption of notional advanced fixed wing aircraft (by 60 % relative to a baseline Boeing 737-800 aircraft with CFM56-7B engines) in the 2030-2035 time frame. The research investments described herein are aimed at improving propulsive efficiency through higher bypass ratio fans, improving thermal efficiency through compact high overall pressure ratio gas generators, and exploring the potential benefits of boundary layer ingestion propulsion and hybrid gas-electric propulsion concepts.

I. Introduction

In 2008, the NASA Fixed Wing (FW) Project (then known as the Subsonic Fixed Wing project) funded system studies¹⁻⁵ of notional future fixed-wing aircraft concepts that could be viable for commercial aviation in the 2030-2035 time frame. NASA required that these concept aircraft meet very aggressive metrics for fuel/energy consumption, emissions, and noise. A detailed description and assessment of propulsion systems and technologies considered in these system studies, and recommendations for technologies that merited further investigation, were reported by Ashcroft, et al⁶. The FW Project has identified several propulsion system themes that have emerged from the system studies as showing potential to significantly reduce fuel/energy consumption. These propulsion system themes are (i) cleaner, compact higher bypass ratio propulsion, (ii) unconventional propulsion-airframe integration, and (iii) hybrid gas-electric propulsion. The FW project has established the following high-level propulsion system technical challenges based on these themes to guide research investments; (i) compact high overall pressure ratio (50+ OPR) gas generators to increase fan bypass ratio and improve propulsive and thermal efficiency, (ii) integrated boundary layer ingestion system to achieve a vehicle-level net system fuel/energy consumption benefit on a representative vehicle, by improving propulsive efficiency and reducing aircraft drag, and (iii) high power density electric motors (four times existing state-of-the-art, SOA), and power management and distribution for future notional hybrid gas-electric propulsion systems. These investments are aimed at meeting the challenging metric of reducing thrust specific fuel/energy consumption by 60 % relative to a baseline Boeing 737-800 aircraft with CFM56-7B engines.

The specific propulsion system research and development activities currently funded under the FW Project to address these high level technical challenges are described in this paper. These activities include research conducted at the four NASA Aeronautics Research Centers (Glenn, Langley, Ames, and Dryden), as well as work done under contracts and cooperative agreements by academic and industry partners to augment NASA in-house efforts.

¹ Technical Lead for Propulsion Efficiency, Fixed Wing Project, NASA Glenn Research Center, Cleveland, OH.

² Manager, Fixed Wing Project, NASA Glenn Research Center, Cleveland, OH, Senior Member.

³ Deputy Project Scientist, Fixed Wing Project, NASA Ames Research Center, Moffett Field, CA, Senior Member.

II. Propulsion System Technical Challenges and Research Portfolio

As shown in Fig. 1, improvements in both gas turbine engine cores (i.e., gas generators) and propulsors (i.e., fans) contribute to reducing thrust specific fuel consumption (TSFC). Advancements in core and propulsor technologies to date have led to high bypass ratio (BPR) engines, such as those deployed on Boeing 747/777 aircraft, that have provided significant reductions in thrust specific energy consumption relative to the original Whittle engine and turbojet engines. Further reductions in thrust specific fuel consumption are possible with technology advancements to enable ultra-high BPR fans and engine cores operating at higher overall pressure ratio (OPR) for increased propulsive and thermal efficiency. Given the physical constraints on maximum fan nacelle diameter, an alternative approach to increasing fan BPR is to reduce the engine core diameters and flow size. In order for a smaller flow size core to provide the power necessary to drive the higher bypass ratio fan the engine OPR must increase to around 50+; the higher OPR increases the engine thermal efficiency as shown in Fig. 2, and contributes to reducing TSFC. It is also necessary to increase the temperature of the air entering the turbine section that extracts energy from the air to drive both the core and the fan. The more energy that can be put into the air, raising its temperature, the more energy that is available for the turbine to extract. If more energy is available for extraction, the turbine size can be reduced, leading to a smaller lighter engine and less fuel expended for the aircraft to carry it. Current turbine inlet temperature technology limits and the goal of the FW project 2030-2035 time frame for “N+3” generation engines are shown in Fig. 3. Increases in the turbine inlet temperature will require either advanced materials that can withstand the higher temperatures, or cooling the turbine blades with high-pressure air from the exit of the compressor. The latter option reduces the overall efficiency of the engine by diverting high-pressure air from the combustor and expending energy in routing air from the compressor to supply the turbine cooling.

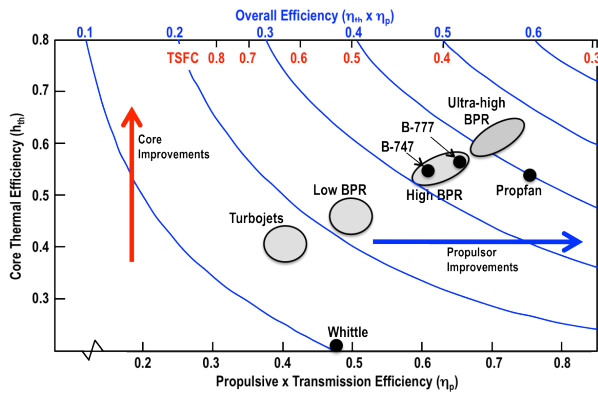

Figure 1. Overall gas turbine engine efficiency as a function of core thermal efficiency, propulsive and transmission efficiencies.

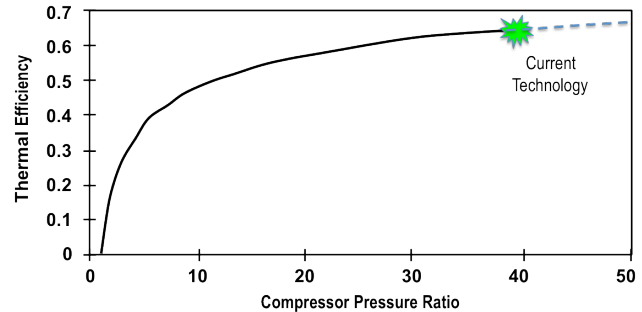

Figure 2. Thermal efficiency as a function of compressor overall pressure ratio (OPR).

The small flow size and higher engine OPR results in engine core aft stages operating at exit corrected flows on the order of one-sixth that of current state-of-the-art (SOA) engines cores for fixed wing commercial transport aircraft. The much smaller exit corrected flows and engine constraints associated with maximum blade tip speed and engine shaft size results in blade tip-clearance gaps that are more than double that of current SOA. As blade tip clearance gaps increase, clearance gap leakages and endwall losses increase, reducing the efficiency of the core and thereby eroding the thermal efficiency benefits of the higher OPR engine. Similarly, blade tip gaps in the first stages of the high pressure turbine (HPT) also increase with decreasing engine flow size, and the attendant increase in tip leakage and endwall losses reduces the HPT efficiency. In addition, turbine disk purge cooling flows can become large relative to the mainstream flow as flow size is reduced, further eroding the thermal efficiency benefits of the high OPR engine. Technology investments are therefore required to mitigate the losses associated with the aft stage core and HPT blade tip clearance gap leakage and endwall losses in order to retain the thermal efficiency benefits afforded by the high OPR engine cycle.

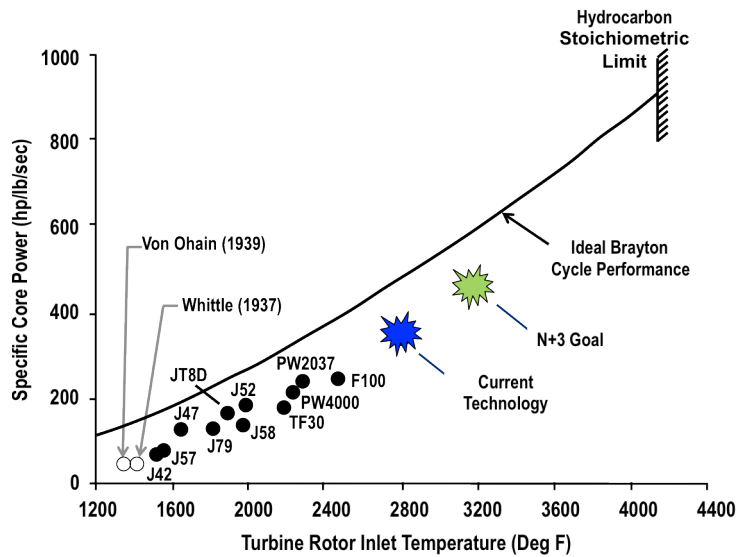

Figure 3. Specific core power as a function of turbine inlet temperature.

The higher 50+ OPR engine cycle also results in higher temperatures in the aft core stages, requiring advances in blade and disk material capability for maximum turbomachinery component efficiency and in order to reduce or eliminate chargeable turbine cooling air. The 50+ OPR engine results in compressor exit temperatures on the order of 1500F (816C) near the rotor rim, which is the same air used for turbine bore cooling purge flow, and exceeds current turbine disk material capability. Also, in order to accommodate the HPT temperatures commensurate with the 50+ OPR engine, the first stage stator vanes and rotor blades must withstand surface temperatures on the order of 3000F (1649C), and 2700F (1482C) with adequate, likely full-life, service capability. Technology investments are therefore required to develop compressor and turbine disk materials and high pressure seals that can accommodate 1500F (816C) conditions, and ceramic matrix composite (CMC) vanes and blades that can accommodate 3000F (1649C) and 2700F (1482C) temperatures, respectively, without requiring blade cooling flow. A more in-depth assessment of aeropropulsion for commercial aviation in the 21st Century and research directions needed with respect to gas turbine propulsion is provided by Epstein⁸.

The potential for reduced aircraft drag and possibly improved lift exists from propulsors that are highly integrated with the wing or fuselage and may serve as “flow control devices” by ingesting significant portions of the wing or aircraft boundary layer flow and filling in the aircraft wing or fuselage wake to reduce aircraft drag and potentially improve lift. The drawback of having propulsors that are highly integrated with the airframe or wing is the consequent detrimental impact on the propulsor (fan) performance and life from having to continually ingest a distorted inlet flow profile, thereby reducing the efficiency and stall range of the fan relative to operating with undistorted inflow conditions. To realize the maximum performance benefit for fuel burn reduction it is necessary to minimize the fan inflow distortion and design a robust fan stage tolerant to continuous ingestion of inlet distortion. A fan operating with continuous inlet distortion may have lower performance potential (peak efficiency and stall range) relative to one designed to operate continuously with undistorted inflow at cruise conditions. Technology investments are therefore required to assess the performance potential of boundary layer ingesting propulsion systems that are highly integrated with the aircraft wing or fuselage, and to determine the tolerable fan stage efficiency and stall margin decrement that still results in significant fuel burn reduction while also being structurally robust for full-life service capability.

Finally, future hybrid gas-electric vehicle concepts hold promise in providing significant reductions in fuel/energy consumption, emissions, and noise. Investments in such far-term technologies are thus warranted, but these benefits will likely require major technical breakthroughs. The key “long pole” hybrid gas-electric technologies identified by the FW Project for investment are the development of electric motors and components with four times the power density of the current SOA, and the management and distribution of megawatt-range electric power in the aircraft for the duration of its flight mission.

As detailed in the discussion above, the FW Project is currently investing in research with the potential to contribute to overcoming the identified high-level propulsion system technical challenges. Such research includes:

- 1) Enabling higher temperature capable disk and turbine blade/stator materials.

- 2) Reducing endwall and tip leakage losses of low exit corrected flow gas generator stages with large tip clearance gap to accommodate the high temperatures and retain thermal efficiency benefits of 50+ OPR gas generators.
- 3) Enabling efficient, robust high bypass ratio fans tolerant to inflow distortion from highly-integrated propulsion systems that ingest aircraft boundary layer flow.
- 4) Enabling efficient higher power density electric motors for future hybrid gas-electric propulsion aircraft concepts.

In addition to the above, other research and technology development activities of interest include: enabling capability for managing and distributing power (eventually up to 50MW) for future hybrid gas-electric propulsion concepts, and developing fan blades that adapt to engine operating conditions throughout the aircraft flight envelope. Of course, there are a number of other potential technologies to enable advancements in future commercial aviation transports, but limited resources make it necessary to prioritize and focus on a limited set of promising technologies with the highest potential impact and with the perceived ability to be realized in the 2030-2035 time frame. The research and technology development activities currently funded by the FW Project are discussed according to the various propulsion research themes described above in the following sections.

A. Cleaner, Compact High Bypass Ratio Propulsion

The “cleaner” aspect of this high level challenge pertains to the reduced emissions goal obtained from combustor technology investments and is therefore not described in this paper. As stated above, the technical challenges to achieving compact high bypass ratio propulsion systems are centered around two aspects: (i) achieving a smaller, compact, high efficiency gas generator to enable increased bypass ratio for a fixed diameter nacelle, thereby improving propulsive efficiency, and (ii) increasing overall pressure ratio (OPR) of the gas generator, and hence improving thermal efficiency, to achieve the aircraft power and propulsion requirements with a smaller flow size gas generator while also operating with uncooled turbine blades to reduce chargeable cooling. The former entails mitigating the losses associated with the larger tip clearance gap leakage and endwall flows, and the latter requires development of high temperature materials and seals to enable the high OPR engine.

1. Mitigating tip clearance gap leakage and endwall loss

The smaller, compact, high efficiency gas generator operating at high OPR (50+) results in aft stages operating with very low, on the order of 1-2 lbm/s (0.45-1 kg/s), exit corrected flows with blade heights on the order of 0.5 inches (1.27 cm) or less and blade tip-clearance gaps on the order of 4% of blade span, relative to current state-of-the-art gas generators with exit corrected flows on the order of 6 lbm/s (2.7 kg/s), blade heights of 0.75 inches (1.91 cm) and blade tip-clearance gaps on the order of 1-2% of blade span. The resultant larger blade tip-clearance gaps increase endwall/tip clearance gap leakage losses, reducing component efficiency (thereby reducing thermal efficiency benefits), and the small blades challenge manufacturing capability and blade robustness.

To help address the tip clearance gap leakage and endwall losses the FW Project initiated a NASA Research Announcement (NRA) call for proposals to improve understanding and mitigate tip clearance gap leakage and end wall losses in high pressure ratio cores⁷. Five three-year NRAs were awarded in the summer of FY11 to teams from: Purdue University/Rolls-Royce, Johns Hopkins University (JHU), Pratt & Whitney/Penn State University (PSU), Honeywell/University of Notre Dame (UND), and U.S. Naval Academy/Cleveland State University (CSU). All the NRAs involve detailed measurements and computational analyses for at least two tip clearance gaps to elucidate the fundamental physics of the endwall/tip clearance leakage flows, and some of them propose to test concepts to mitigate losses and improve efficiency of small cores with large tip clearance gaps. Two of the NRAs focus on compressor and three on turbine endwall/tip clearance flows. The FW project also awarded a Phase II NRA to Massachusetts Institute of Technology (MIT)/Pratt and Whitney to study and identify the technical challenges to developing small core compressors and investigate novel concepts to address the small core challenge.

Professor Katz and his students at JHU are addressing compressor tip clearance/endwall flows in a 1-1/2 stage compressor with acrylic blades and casing and a working fluid that is a concentrated solution of sodium iodide (NaI) in water (63% by weight) to match the optical refractive index of the blades and casing material. The casing and blades thus become almost invisible, allowing unobstructed measurements almost everywhere without concern for flare light from the laser beams impinging on metallic surfaces. This technique provides the opportunity for much greater detailed measurements of the tip clearance/endwall flow field than is possible with metallic blading, especially as the blades cut through the path of the laser beam. The JHU 1-1/2 stage compressor is a reduced scale model of the upstream 1-1/2 stages of the NASA Low Speed Axial Compressor (LSAC), which in turn was patterned after the GE Energy Efficiency Engine (E³) geometry. To retain adequate rotor blade thickness for

structural integrity, the rotor blade tip was required to be 0.25 inches (6.35 mm) thick. Due in part to power limitations of the JHU facility, which pumps a mixture of water and NaI, a direct scale model of the LSAC geometry was not deemed feasible. In order to maintain solidity for aero-similitude, the rotor and stator chords were increased and the number of rotors and stators decreased. Numerical simulations of the scaled geometry showed satisfactory operation. Figure 4 is a schematic of the JHU turbomachinery facility with the new NASA compressor setup installed, and Fig. 5 is an enlarged cross section of the new NASA 1-1/2 stage axial turbomachine. A blow-up of just the 1-1/2 stage axial turbomachine indicating transparent/acrylic hardware shown in Fig's. 6 and 7 includes a 3D representation of the three compressor blade rows and a photographic view from the inlet guide vane (IGV) inlet, within the transparent casing, showing the transparent/acrylic blades and hub with bearing assembly. The NaI working fluid with index of refraction matched to the transparent/acrylic components provides unobstructed optical access, even through the rotating blades, thereby facilitating Stereo PIV (partical image velocimetry) in axial and circumferential planes through the compressor, Fig. 8, and Tomographic PIV, Fig. 9, which provides full 3D time resolved measurements to capture details of the leakage vortex.

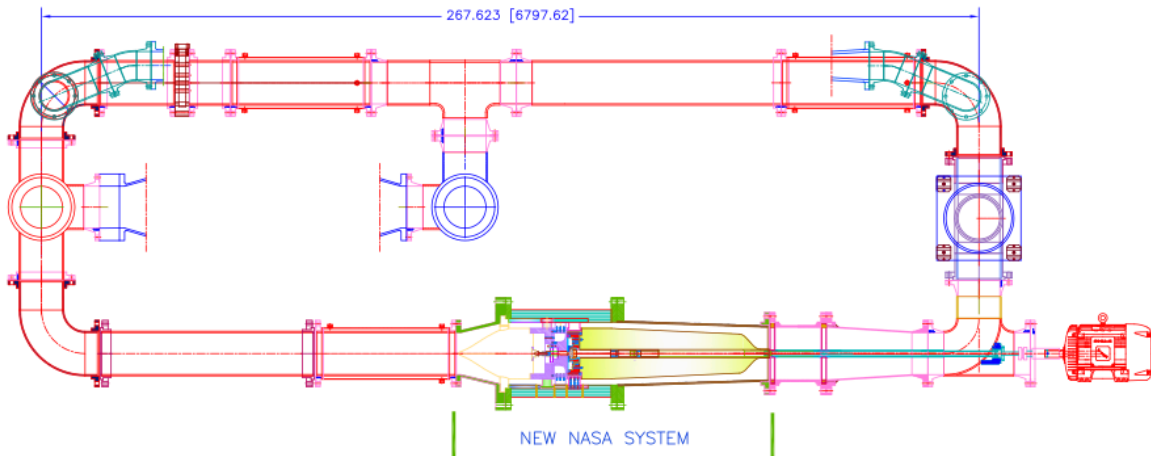

Figure 4. The JHU turbomachinery facility with the new NASA compressor setup installed.

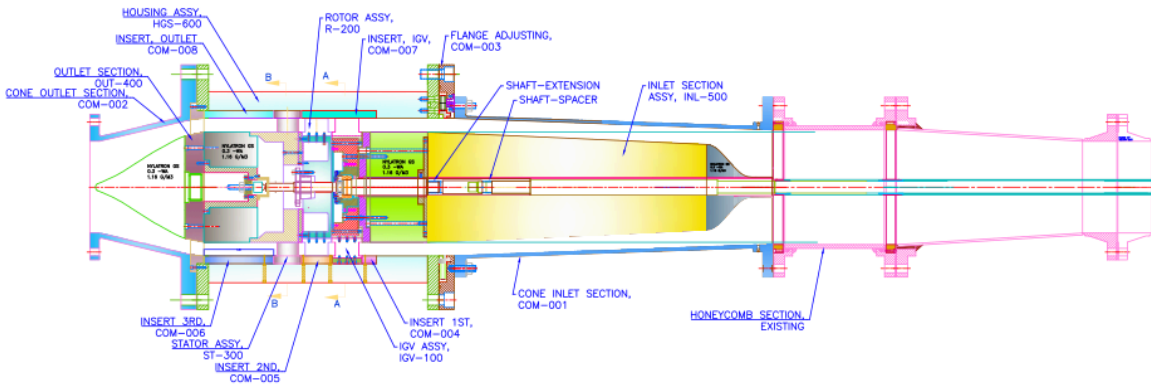

Figure 5. A magnified cross section of the complete NASA 1-1/2 stage axial turbomachine setup.

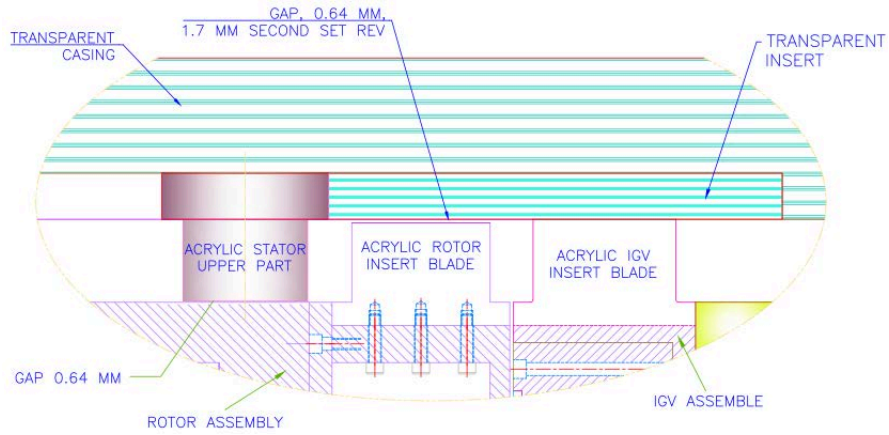

Figure 6. Blow up of the 1-1/2 stage axial turbomachine depicting transparent/acrylic hardware.

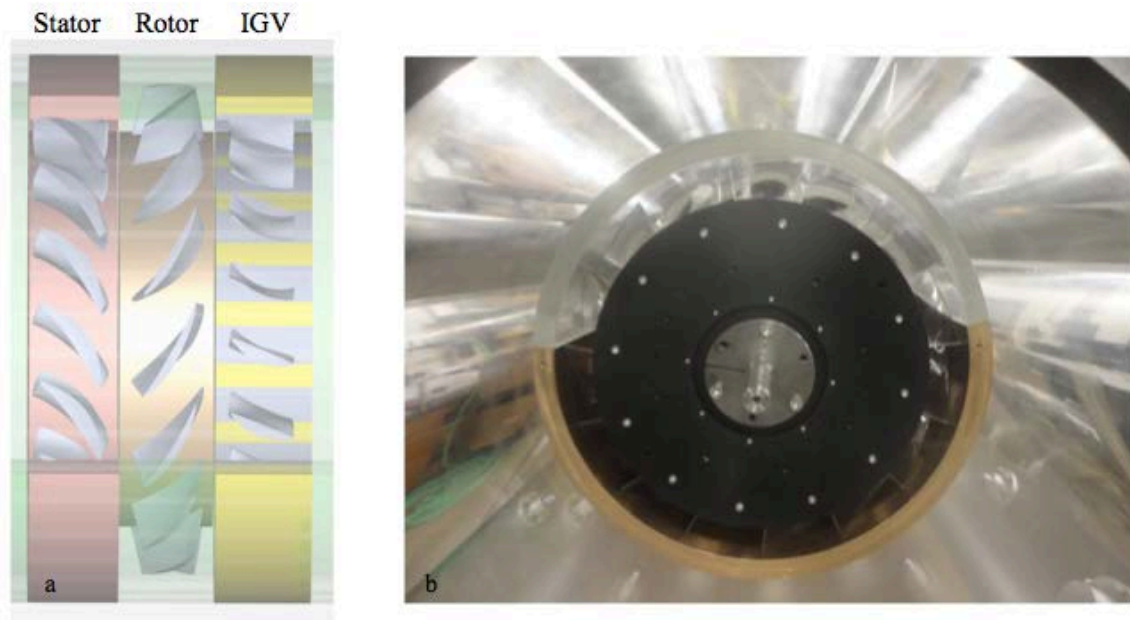

Figure 7. a) Three compressor blade rows. Flow is from right to left; and b) photographic view from IGV inlet, within the transparent casing, showing the acrylic blades and hub with bearing assembly.

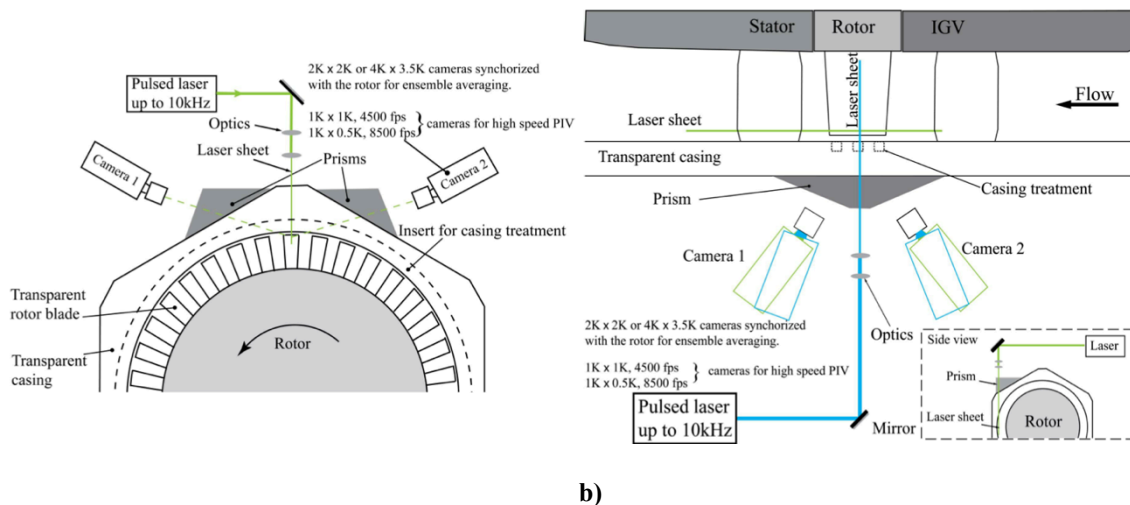
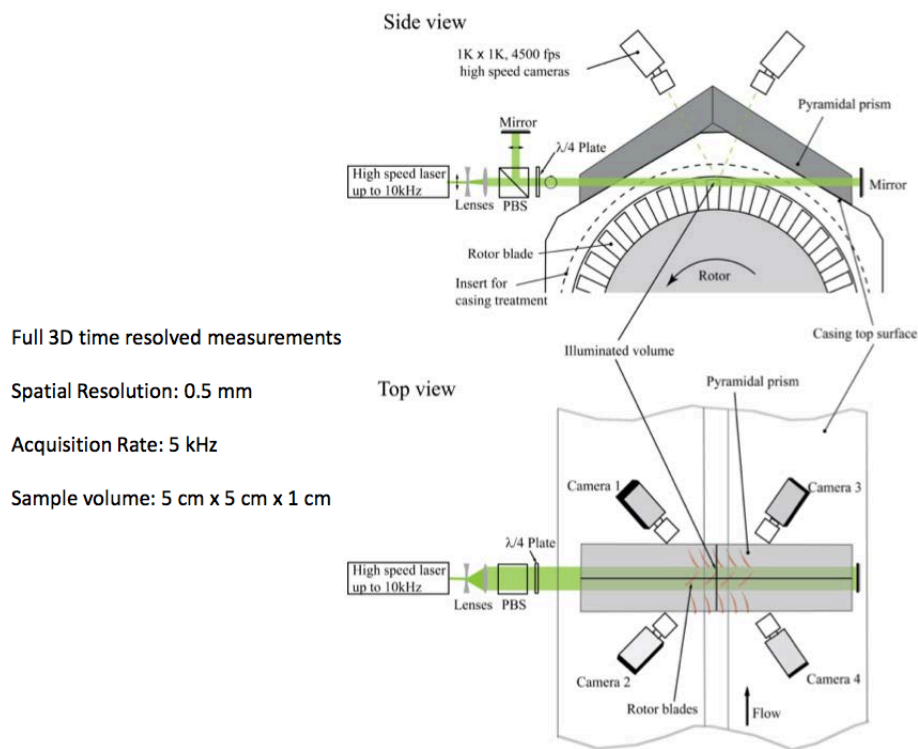

Figure 8. Stereo PIV setup for a) axial and b) blade-to-blade planes.



Full 3D time resolved measurements
 Spatial Resolution: 0.5 mm
 Acquisition Rate: 5 kHz
 Sample volume: 5 cm x 5 cm x 1 cm

Figure 9. Setup of Tomographic PIV system.

Professor Key and her students at Purdue University are testing a Rolls-Royce designed 3-1/2 stage compressor, Fig's. 10 and 11. The compressor will be tested in the Purdue 3-stage research facility with 1.5, 3, and 4% tip clearance gaps based on annulus height. This allows comparison of typical tighter clearances achievable for larger core sizes with the larger clearance gaps expected of small, ~1.5 lbm/s (3.3 kg/s), core compressors with blade spans less than 0.5 inches (13 mm). The rotor tip clearance is varied from the baseline clearance by recessing the casing over the rotors to effect larger rotor blade tip gaps. The Purdue effort is focused on obtaining detailed measurements of the overall and stage performance of the compressor via flow field traverses upstream and downstream of blade

rows using steady instrumentation probes and unsteady high response kulites and hot-wires. In addition, volumetric illuminating particle image velocimetry, Fig. 12, and Tomographic image velocimetry, Fig. 13, may also be employed to capture greater detail of the endwall/tip clearance flow physics. Complementary steady and unsteady CFD simulations are also being conducted for additional insight and will be validated by the experimental data being acquired. Testing with conventional probes, hot-films, and high response casing kulites has already begun and the initial results look promising.

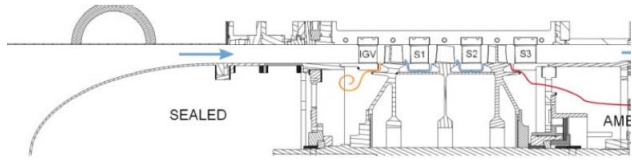
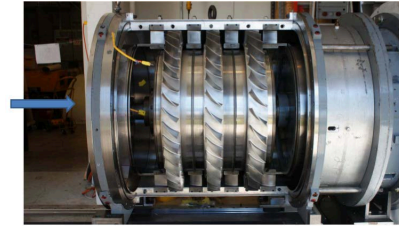

Figure 10. Meridional view of the Purdue 3-1/2 stage research compressor.



	IGV	R1	S1	R2	S2	R3	S3
No.	44	36	44	33	44	30	50
AR	1.00	0.76	0.95	0.72	0.90	0.68	0.85
Sol.	1.27	1.37	1.34	1.33	1.42	1.28	1.70

Figure 11. Purdue 3-1/2 stage research compressor hardware and blade geometry.

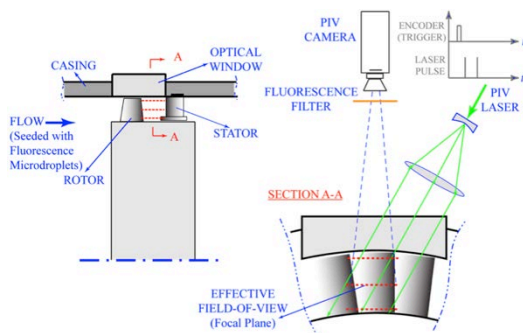

Figure 12. Volumetric illuminating PIV.

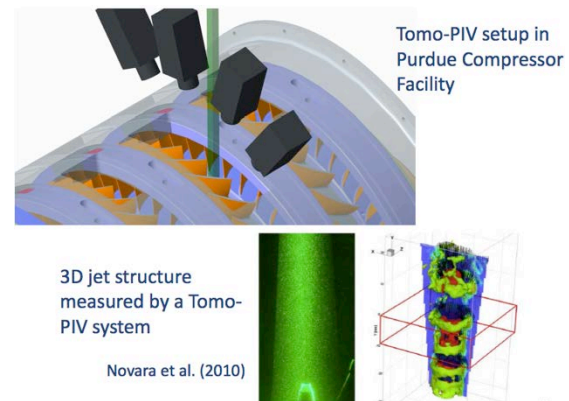

Figure 13. Tomographic PIV setup.

Professor Volino at the US Naval Academy is investigating the unsteady endwall and tip gap flows in turbine blades using a low speed cascade facility, with rotating “wake” generator bars to simulate the periodic unsteady flow from the adjacent upstream blade row, as shown in Fig’s. 14 and 15. The E³ rotor blade tip section and blade angles were selected to match the geometry and blade angle settings recently tested in the NASA CW-22 high-speed cascade facility. The low speed cascade tests are intended to document the unsteady response of the turbine rotor endwall flow, with and without tip gaps, to unsteady wakes from adjacent upstream rotating bars using Kiel probes, hot-wires, PIV, and other measurement techniques. The measurements are intended to improve understanding of the turbine tip leakage and endwall flow physics with increased rotor blade tip clearance (~4-5% of blade span), to help guide techniques for controlling tip flows using passive or active blowing techniques to reduce engine performance degradation with respect to tight tip clearances (~1-2% of blade span). To complement the experimental measurements, currently underway, Professor Mounir Ibrahim at Cleveland State University is performing high fidelity CFD simulations of the experimental configuration.

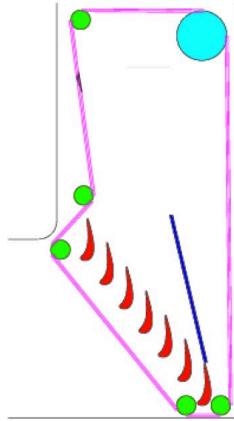

Figure 14. Schematic of USNA turbine cascade and rotating bar arrangement.



Figure 15. Photo of turbine cascade blades and rotating bar installed in USNA test facility.

The Pratt & Whitney/PSU NRA is aimed at understanding and reducing high pressure turbine endwall/rim-cavity secondary flow and tip clearance losses. The experimental investigations involve testing in PSU's low speed cascade (LSC), Fig. 16 (a), and high speed axial flow turbine research facility (AFTRF), Fig. 16 (b), which will provide detailed, benchmark-quality aerodynamic and cooling effectiveness data to validate CFD design analysis and verify optimization approaches to minimize turbine endwall, rim cavity, and endwall clearance losses. The three times scale LSC geometry and AFTRF test hardware have been aerodynamically matched as shown in Fig. 17, and the features of the interchangeable rim-cavity and instrumentation are shown in Fig. 18. The figure shows a movable bluff body to investigate dependency and characteristics of the cavity purge flow to the downstream rotor potential flow field. The LSC test section is complete, and the AFTRF hardware has been assembled and instrumentation development is underway. Initial LSC tests have begun and the next steps are to fabricate the LSC bluff body, complete the LSC test matrix, and then complete the baseline AFTRF testing.

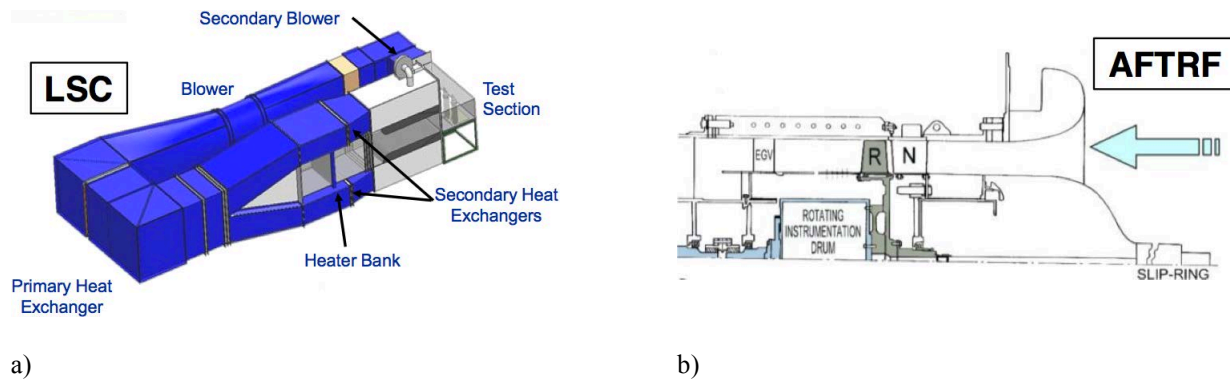

Figure 16. (a) PSU low speed cascade (LSC), and (b) axial flow turbine research facility (AFTRF).

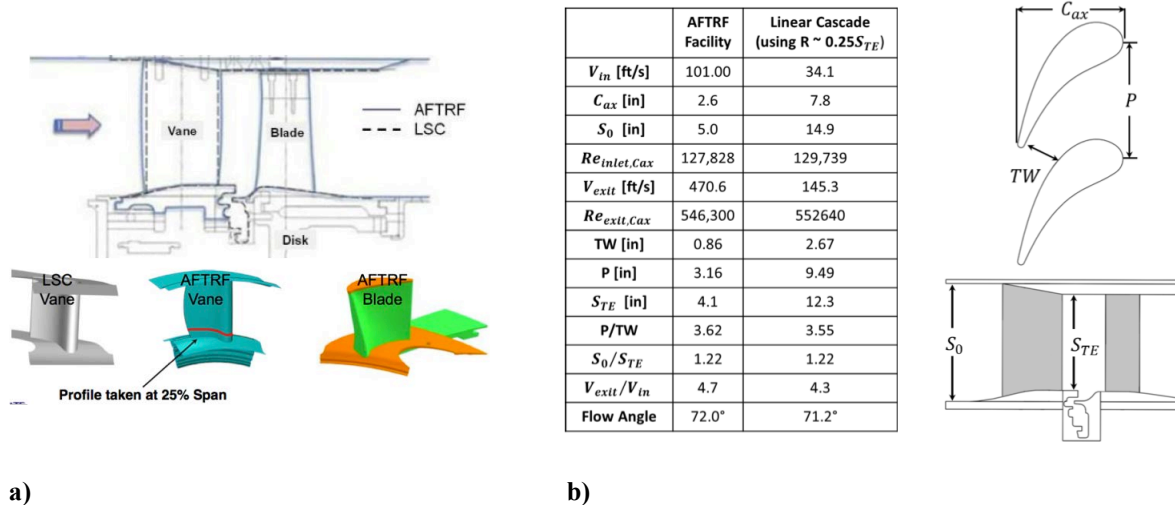

Figure 17. (a) Comparison of PSU 3x scale LSC blade geometry to AFTRF blade, and (b) matching of aerodynamic parameters.

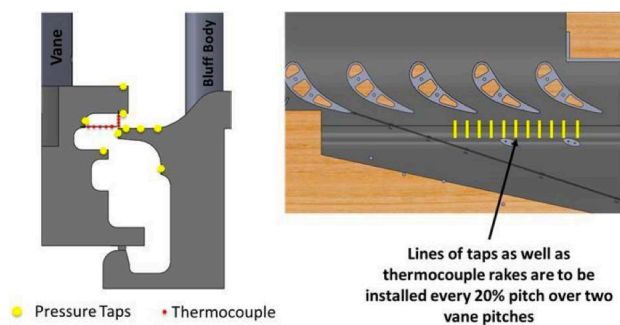
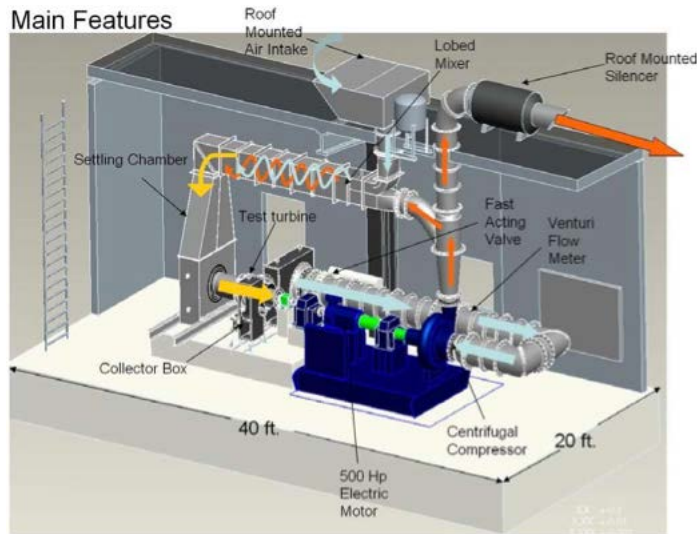

Figure 18. LSC interchangeable rim cavity geometry and instrumentation, and movable downstream bluff body and instrumentation.

The Honeywell/UND effort involves the design and subsequent testing of a new HPT turbine in the UND turbine test facility, Fig. 19. The initial HPT stage design parameters are provided in Table 1. CFD tools and design of experiments (DOE) are employed to identify high-pressure turbine (HPT) design parameters that influence the blade tip leakage and endwall losses and erode overall performance, and to select blade tip parameters and endwall contouring for optimized HPT stage efficiency. The analyses include a variety of CFD techniques (RANS/URANS, harmonic methods, LES and/or DES).

Four different concepts were considered in the design: (i) unloading the tip by changing tip geometry or by reducing work level at the tip, (ii) implementing barriers to tip flow such as squealer tips, winglets or fences, as shown in Fig. 20, (iii) examining the impact of airfoil static pressure loading on the tip leakage vortex, and (iv) endwall contouring. The optimized HPT design obtained from the initial CFD and DOE results has reduced tip reaction, 10% higher rotor blade count, 20% larger tip section axial chord, and 0.7% higher efficiency compared to the baseline design. The optimized stage is being built for testing in the UND transonic test facility. The resulting data will be analyzed and additional high fidelity calculations will be performed.



a) UND test facility

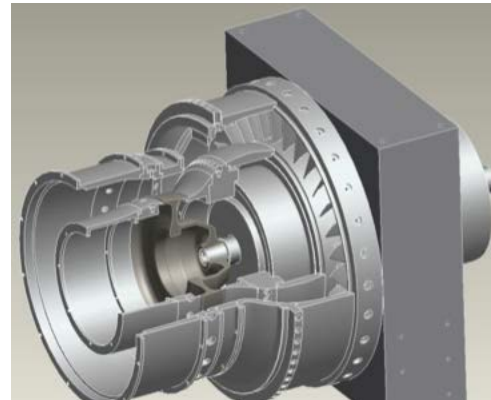

b) New HPT rotor

Figure 19. (a) UND test facility, and (b) new HPT rotor.

Table 1. Initial UND HPT design parameters.

HON-ND HPT Iter 5a		HON-ND HPT Iter 5a			
Corrected Flow	[lbm/s]	10.660	Rx_{HUB}	33.5%	
Corrected Speed	[rpm]	10,102.2	$A_{N,EX}$	[in ²]	95.73
Corrected Work	[Btu/lbm]	19.412	AN^2	[in ² -rpm ²]	1.18E+10
Corrected Power	[hp]	292.82	$(\eta/\rho)_{AVG}$		0.715
PR(T-T)		1.9275	R_{TIP}	[in]	7.794
Cycle Efficiency		91.21%	Tip Clearance	[in]	0.023
Non-Chargeable Flow	[%W4.1]	0%	Vane Ψ_{2D-INC}		0.845
Chargeable Flow	[%W4.1]	2.3%	Blade Ψ_{2D-INC}		1.133
$\Delta h_t/U^2$		1.397	Reynolds No.		602,000
Vx/U		0.5625			

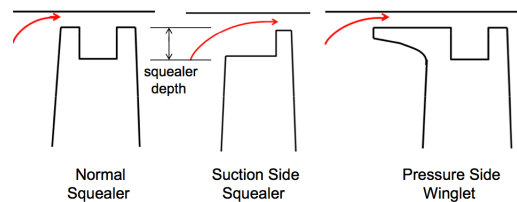

Figure 20. Blade tip design modifications proposed to reduce leakage loss.

The MIT/P&W NRA is aimed at identifying the technical challenges to developing small low-exit-corrected-flow aft-stage core compressors, and investigating novel concepts to address the small core challenge¹⁰. Analyses of Reynolds number effects and performance assessment of tip clearance gap in high pressure compressors has focused on the D8.5 engine for the MIT Double Bubble boundary layer ingesting aircraft concept. A comparison of the notional size of an anticipated future small core (denoted N+3) relative to a CFM56-7 core (~22 klbf, 100 kN, thrust class) is shown in Fig. 21 and illustrates the challenge of increasing OPR for this engine class. MIT’s analysis of Reynolds number effects, Fig. 22, indicate the D8.5 compressor mid-stages achieve the lowest Reynolds numbers. MIT has also investigated the performance impact of three HPC conceptual scaling configurations, Fig. 22.

- 1) Pure “photo” scale – Takes a modern compressor with a hub-to-tip ratio of 0.93 at the last stage and scales it to a lower corrected flow,
- 2) Shaft limited – Assumes the LP shaft radius sets the minimum radius. Mean radius is larger than from photographic scaling, and
- 3) Shaft removed – Eliminates the LP shaft constraint and pulls in the flow path. Hub-to-tip ratio decreased to 0.85 for a 1.5 lbm/s (0.68 kg/s) core.

MIT then assessed the compressor efficiency impacts according to the following five steps: (i) determine blade sizes, Re numbers, and tip clearances, (ii) calculate Re number efficiency penalty of each stage, (iii) calculate tip clearance efficiency penalty of each stage, (iv) calculate compressor polytropic efficiency, (v) determine aircraft fuel burn with TASOPT⁹ (Transport Aircraft System OPTimization) a program for simultaneously optimizing the airframe, engine, and operating parameters of a wing and tube transport aircraft. The results are shown in Fig. 24.

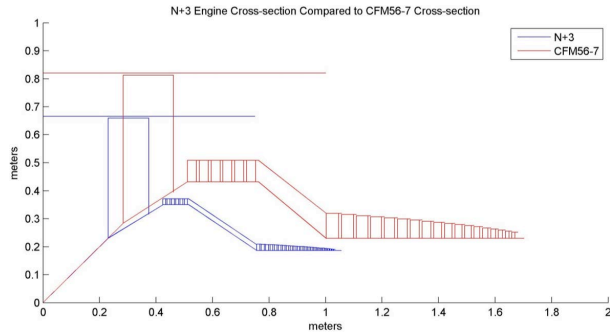

Figure 21. Scaling CFM56-7 to future (denoted N+3) engine size¹⁰.

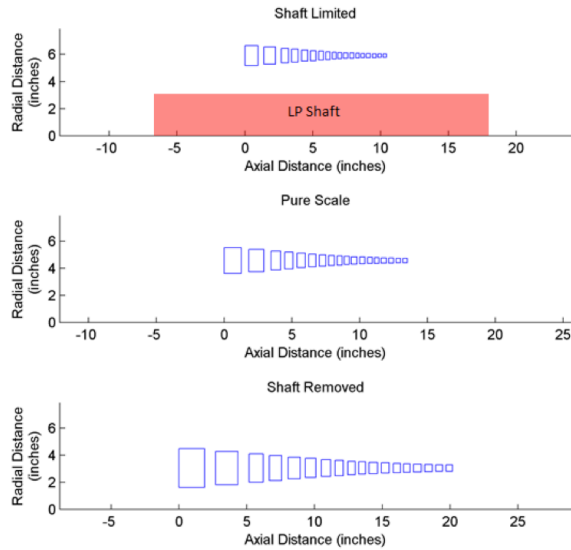

Figure 23. Impact of different scaling dependent on shaft constraint¹⁰.

2. Developing high temperature materials, coatings, and seals to enable the higher 50+ OPR engine.

To enable a 50+ OPR engine, material advancements are required to accommodate the higher compressor exit temperatures (around 1500F, 816C, near the rotor rim), and is the same air used for turbine bore cooling purge flow, requiring development of higher temperature capable turbine disk materials. Furthermore, to accommodate the HPT temperatures commensurate with the 50+ OPR engine the first stage stator vanes and rotor blades must withstand surface temperatures on the order of 3000F (1649C), and 2700F (1482C) with adequate, likely full life, service capability. Technology investments are therefore required to achieve compressor and turbine disk materials and high pressure seals that can accommodate 1500F (816C) conditions, and ceramic matrix composite (CMC) vanes and blades that can accommodate 3000F (1649C) and 2700F (1482C) temperatures, respectively, without requiring blade cooling flow. Both the high temperature disk and CMC blade material will require coatings for environmental and thermal protection. The development of CMC turbine materials to accommodate the high temperature engine cycle is being managed and supported by the Aeronautical Sciences Project under the NASA Fundamental Aeronautics Program and will therefore not be discussed herein.

The FW project is currently investing in the development of hybrid-disk materials to withstand 1500F (816C) turbine rim conditions and 1300F (704C) bore temperatures, Fig. 25 (a), and coatings to protect against hot-corrosion. Hurst¹¹ has reported a recent comprehensive overview of materials and structures research focused upon propulsion applications within the FW Project. Recent test results by materials researchers at the NASA Glenn Research Center indicate that the right combination of optimal superalloys and microstructures at the bore/web and rim could enable a 1500°F (816C) hybrid disk to accommodate compressor exit temperatures for the 50+ OPR engine. Materials have been selected and initial mechanical properties generated for further study of this hybrid disk

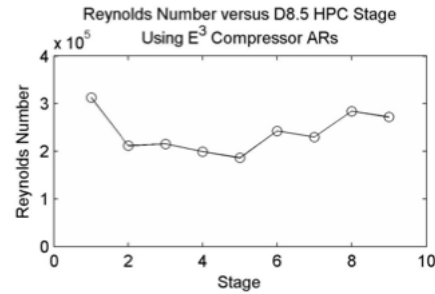

Figure 22. Reynolds number in D8.5 HPC stages¹⁰.

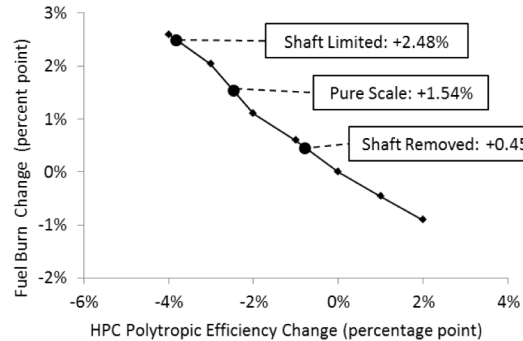

Figure 24. Fuel burn impact as a function of HPC polytropic efficiency and scaling options¹⁰.

concept: a 15 μm grain size low-solvus, high-refractory (LSHR) superalloy bore/web powder metal superalloy and a new NASA low density single (LDS) crystal rim superalloy (LDS1101+Hf). These materials are being tailored to meet the structural requirements of a disk with increased maximum operating temperature of 1500°F (816C) of future high 50+ OPR engines, compared to current 1300F (700C), Fig. 25 (b) and (c). This significantly higher operating temperature would enable the high 50+ OPR engine and thereby could improve engine operating efficiency and reduce fuel consumption. The research and technology development activities to enable the 1500F (816C) capable hybrid disk involves not only the development of the desired materials property characteristics for the super alloy power metallurgy bore/web and the single crystal rim, but also the joining process, including transition location, and coatings for thermal and environmental protection.

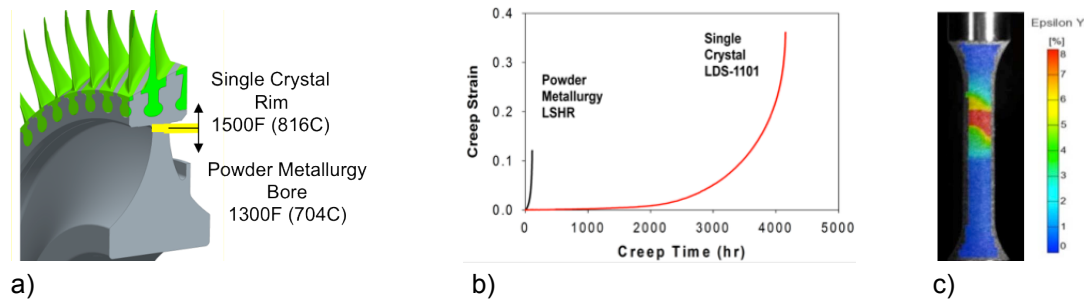

Figure 25. (a) Schematic of a hybrid disk , (b) Creep resistance of LDS alloys required for 816 °C (1500 °F) disk rim temperatures and (c) 3D strain mapping of PM/SX joint indicating most deformation occurs in the single crystal region¹¹.

The FW project is also investing in the development of advanced 1500F (816C) capable non-contacting compliant finger seals to reduce leakage losses and have long life capability. A non-contacting brush/finger turbine seal¹¹ designed by researchers at the NASA Glenn Research Center (GRC) is shown in Fig. 26. Verification and refinement of design methodology using experimental data and analysis is on-going with testing up to 1472F (800C) and pressures up to 1.7 MPa differential (250 psid). The goal is to both validate design and analysis methodology, and to demonstrate low leakage and long life of the compliant non-contacting finger seals. This work is conducted in the GRC High Temperature, High Speed Turbine Seal Test Facility¹², Fig. 27.



Figure 26. GRC non-contacting brush/finger turbine seal.



Figure 27. GRC high temperature, high speed turbine seal test facility¹².

B. Unconventional Propulsion-Airframe Integration

Several of the FW-funded system studies, most notably the MIT Double Bubble² and NASA TurboElectric Distributed Propulsion (TeDP)⁵ aircraft concepts, Fig. 28, departed from the conventional tube and wing configuration of current modern aircraft to capitalize on the potential for significant reduction in fuel/energy consumption afforded by propulsors (i.e., fans) that are more highly integrated with the aircraft wing or fuselage to ingest the wing or fuselage boundary layer. According to the theory of Smith¹³, propulsive efficiency, η_p , of an aircraft is increased when the propulsors are located such that they ingest the wing/fuselage boundary layer flow, Fig. 29, where U_0 , U_j , and U_{in} are the free stream velocity, jet exit velocity, and the inlet velocity, respectively. For the boundary layer ingesting (BLI) case, $U_{in} < U_0$, the propulsive efficiency is higher compared to the non-ingesting case, $U_{in} = U_0$. The larger fraction of wing/fuselage boundary layer fluid ingested by the propulsors the greater the potential reduction in fuel/energy consumption. However, propulsors/fans will likely suffer a reduction in efficiency and stall margin when operating with a distorted inflow, which in this case will be continuous throughout the aircraft flight mission. Therefore, to maintain an overall system benefit the degradation in fan performance due to its interaction with a non-uniform inflow must be sufficiently less than the benefits obtained from ingesting the boundary layer to warrant the unconventional propulsion system/airframe architecture.

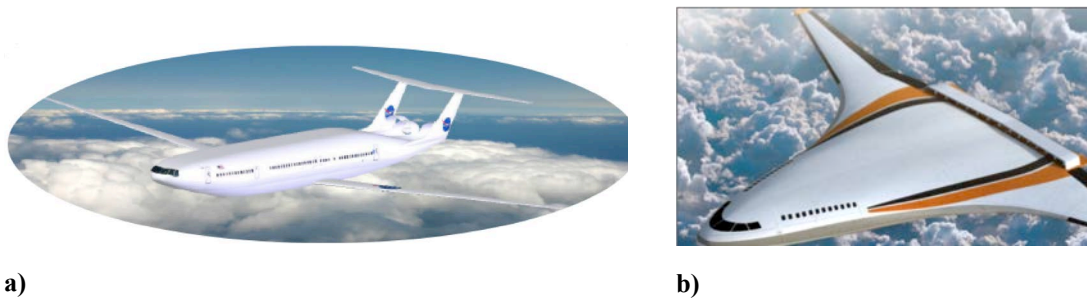

Figure 28. (a) MIT Double Bubble aircraft concept with propulsors ingesting the fuselage boundary layer², (b), NASA TurboElectric aircraft concept with propulsors ingesting the blended wing body boundary layer⁵.

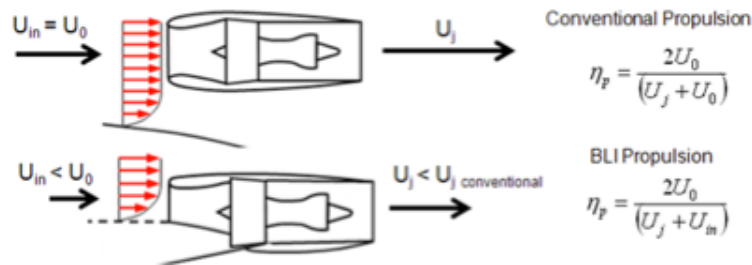

Figure 29. Propulsive efficiency benefit from BLI v.s. conventional propulsion⁶.

Based on industry studies which indicated potential for significant fuel burn reduction of BLI propulsion aircraft concepts¹⁴⁻¹⁶, NASA funded United Technologies Research Center (UTRC), via an NRA, to: 1) conduct system level studies of blended wing body aircraft with integrated BLI propulsion system architecture to assess potential fuel burn benefits relative to a baseline high-performance, pylon-mounted, propulsion system¹⁷, and 2) design a high-performance embedded, boundary layer ingesting, engine inlet and an associated distortion tolerant fan stage to minimize performance penalties of operating with continuous inlet distortion¹⁸⁻¹⁹. The results of the system studies indicated a potential 3 to 5 percent fuel burn reduction for a 5-engine configuration relative to an advanced baseline high bypass ratio turbofan engine, Fig. 30, and also indicated that low-loss inlets and high-performance, distortion-tolerant turbomachines are key technologies to achieve the maximum potential fuel burn benefit. Subsequently, UTRC conducted a hierarchical, multi-objective, computational fluid dynamics-based aerodynamic design optimization that combined global and local shaping to design a high-performance embedded engine inlet¹⁸ and an associated distortion tolerant fan stage¹⁹ for testing in the NASA subsonic 8-ft by 6-ft (8'X6'') supersonic wind tunnel. The UTRC CFD analysis of the optimized boundary layer ingesting inlet and distortion tolerant fan stage

system predicts less than 2% reduction in fan efficiency relative to operation with uniform fan inflow conditions¹⁹. Wind tunnel experiments to validate the CFD prediction results are planned for 2015. The BLI inlet and distortion tolerant fan stage are shown installed in the NASA 8X6 facility, including special test equipment consisting of a raised floor, boundary layer bleed system, and tunnel bump to control and vary the boundary layer profile entering the fan nacelle, and a NASA designed fast acting variable nozzle, Fig. 31. NASA is also designing and fabricating rotatable multi-element rakes (circumferential and spanwise pressure and temperature probes) for the aerodynamic interface plane (AIP) and downstream of the exit of the fan exit guide vanes to measure fan performance parameters. An enlarged view of the distortion tolerant fan and layout of components to be installed in the NASA 8'X6' wind tunnel is provided in Fig. 32.

NASA in-house researchers play a key role in being responsible for the high fidelity CFD analyses and assessments to determine that the fan is aeromechanically sound, and to identify critical speeds to avoid during testing. Such analysis requires extending the capability of their current CFD tools to enable aeromechanical analysis of a fan operating with continuous inlet distortion. This has entailed interpolating the fan inlet distortion from the UTRC simulation results to map their predicted distortion pattern to the NASA CFD code boundary conditions and then conducting unsteady full-annulus simulations to provide assessments of forced excitation and aeromechanical damping²⁰, which included development of additional post-processing capability, Fig. 33. Further planned improvements to the NASA CFD codes for aeromechanical analysis of boundary layer ingesting inlets coupled with distortion tolerant fan stages include incorporating CFD analysis of the boundary layer ingesting inlet with the distortion tolerant fan stage, and developing a closely coupled aerodynamic and structural analysis tool that would continuously update the structural analysis of the blade modes and deflections as the unsteady CFD simulations evolves and the fan blades move in and out of the distortion, rather than current practice where the structural analysis is first completed and the blade modes are fixed during the unsteady CFD simulations.

Another topic of interest that the FW project is supporting research in developing adaptive fan blade technology, which involves training shape memory alloys for embedding in composite fan blades to effect optimal blade shape change to maximize fan efficiency at takeoff and cruise conditions, therefore minimizing fuel burn. Preliminary studies have shown that shape memory alloy wires will have more than adequate capability to achieve the required geometry changes when embedded in the composite. The use of shape memory alloys can also be applied to many other components, such as adaptive inlets, variable area nozzles, and active clearance control systems. The research also includes investigating carbon nanotube materials with the composite fan blades to toughen the blades. This will allow thinner fan blades that will improve aerodynamic efficiency and also be structurally tolerant to bird strikes. The adaptive fan blade research team is also developing analysis tools and methodology to validate the capability for static (non-rotating) testing of fan blades for impact resistance, alleviating the need for conducting multiple rotating fan blade tests of bird strike impact on the composite fan

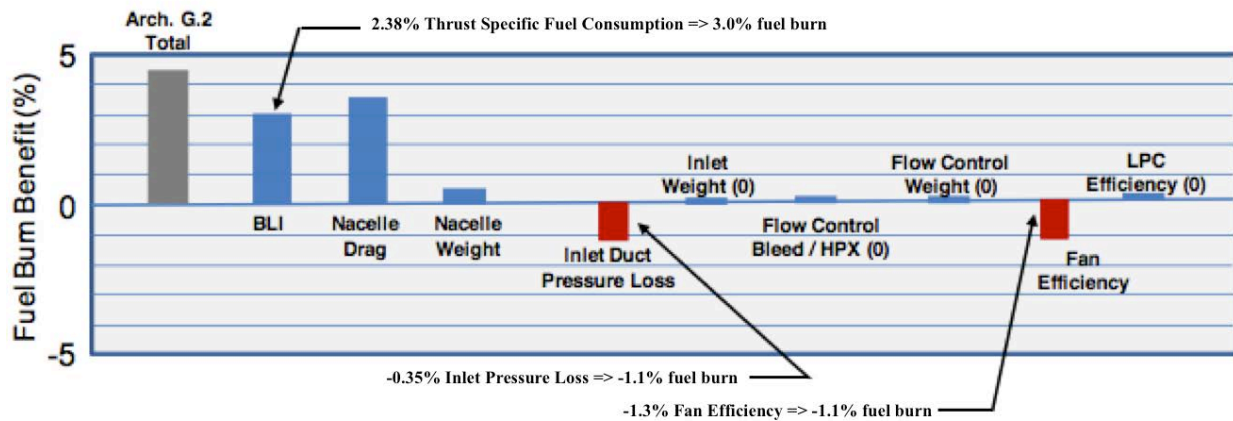

Figure 30. Results from a system study indicating potential fuel burn benefits of BLL propulsion¹⁷.

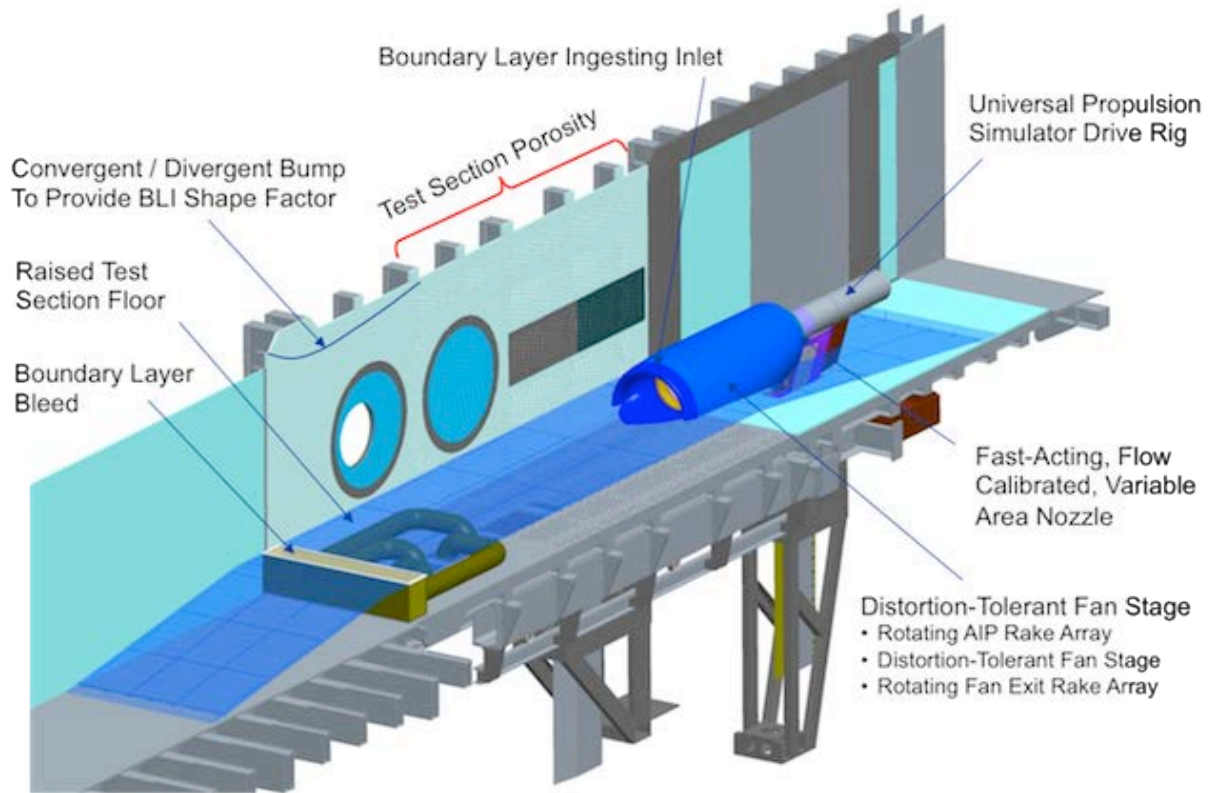

Figure 31. Depiction of UTRC designed BLI inlet and distortion tolerant fan stage installed in NASA 8x6 wind tunnel which includes specialized test hardware.

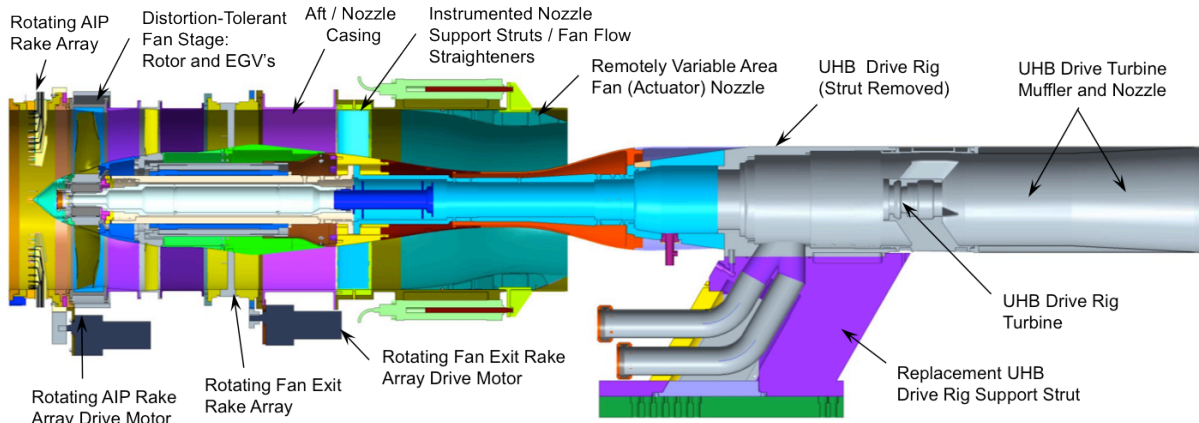

Figure 32. Distortion tolerant fan stage layout of components for installation in the NASA 8'x6' wind tunnel.

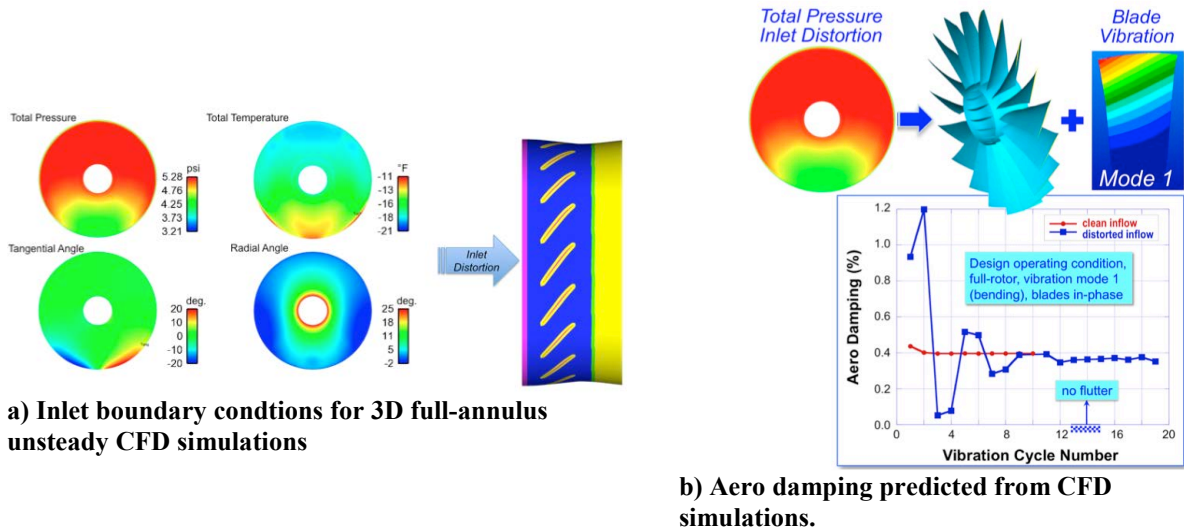

Figure 33. NASA high fidelity CFD for eromechanical analysis of UTRC designed distortion tolerant fan.

C. Hybrid Gas-Electric Propulsion

The N+3 system studies^{1,5} allude to the considerable promise of hybrid gas-electric propulsion to meet the aggressive goals for reducing fuel/energy consumption, emissions, and noise. Hybrid gas-electric propulsion includes concepts that are non-superconducting (e.g., Boeing Sugar Volt¹) or superconducting (e.g., the NASA Turbo-Electric Distributed Propulsion concept, TeDP⁵), and involve having both a gas turbine and electric motor (powered by batteries or other energy source) on the same shaft driving the fan/propulsors, or gas turbine engine generating power for electric motors driving the fan/propulsors. The FW-funded Boeing Sugar (Subsonic Ultra Green Aircraft Research) studies¹, conducted by Boeing in partnership with General Electric and Georgia Tech, showed the SUGAR Volt aircraft came the closest of all the concepts they studied to meeting the N+3 goals with a 63% decrease in fuel burn and a 79% decrease in LTO NO_x emissions. The Sugar Volt involves a GE-developed idea for a hybrid electric-gas turbine engine (hFan) concept that uses batteries to assist during takeoff and cruise, development of a small ultra-high OPR core compressor, as well as other technology advancements, as shown in Fig. 34. The additional power provided by the batteries could potentially allow sizing the gas turbine engine for cruise rather than takeoff. The gas turbine engine could then be powered down or perhaps even shut down during cruise with the battery powered electric motor driving the fans to propel the aircraft. There are no apparent show stoppers, but of course there are a number of technical challenges to address, including development of higher power density batteries and electric motors, before this concept is ready for commercial flight operations.

The NASA Turbo-Electric Distributed Propulsion (TeDP) blended wing body aircraft concept also shows potential in meeting the NASA N+3 fuel/energy consumption, emissions, and noise goals, but requires considerable research and technology advancements to enable the cryogenic electric motors and components. The long-pole technology challenges requiring investments for the TeDP aircraft concept are illustrated in Fig. 35. The FW project is currently focused on supporting the vehicle systems analysis of the TeDP^{21,22}, and the development of the cryo-electric motors both through in-house research and an NRA with Advanced Magnetics Laboratory (AML). Other technologies indicated in Fig. 35 are being pursued using NASA SBIRs or by leveraging investments made by the Air Force and Navy.

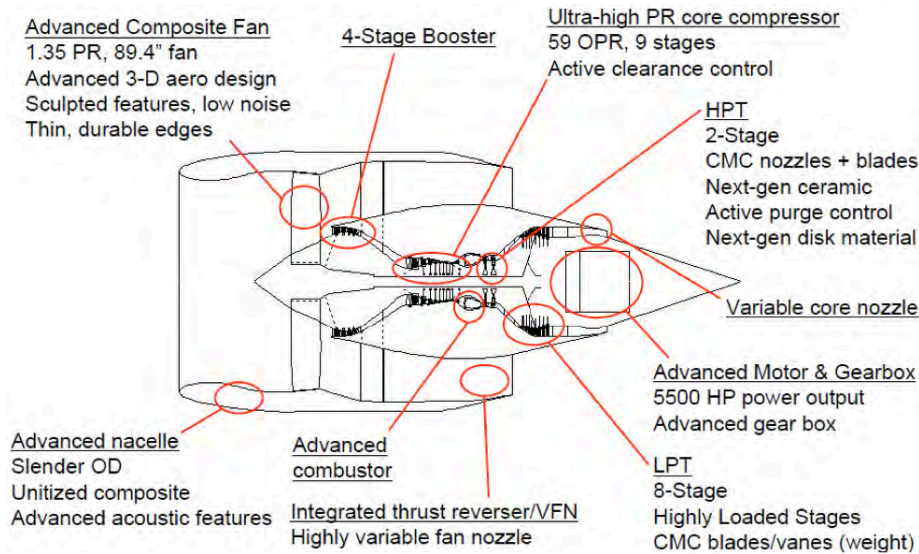

Figure 34. Overview of the GE “hFan” Gas Turbine-Electric Hybrid Engine for the Boeing Sugar Volt.

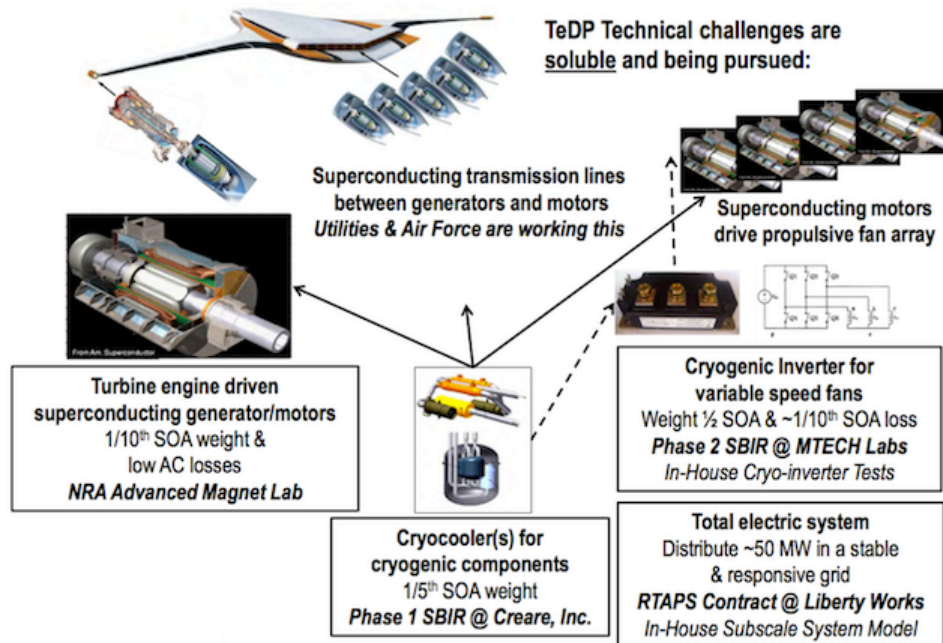

Figure 35. NASA TurboElectric Propulsion aircraft concept, and current technology investments.

The NRA with AML is developing high-fidelity modeling capability to design a low AC (alternating current) loss stator, and in-house efforts are aimed at developing processing of magnesium di-boride (MgB_2) powders to fabricate $10\mu m$ diameter MgB_2 superconducting filaments for motor windings. The FW project also plans in FY14 to augment funding for hybrid gas-electric propulsion technologies to include development of non-cryogenic electric motors, initially aimed at doubling the current SOA in power density by 2020 time frame.

Another research topic of interest is aimed at investigating the challenges of managing and distributing potentially megawatt-level electric power for commercial aviation applications. To this end, the FW project recently funded a contract with Rolls-Royce North America to study the power grid architecture²³ as well stability, transient response, control, and safety of a high-power electric grid²⁴ for turboelectric propulsion aircraft. Rolls-Royce characterized and evaluated the critical dynamic and safety issues for the propulsion electric grid of a distributed propulsion system, and recommended system architecture and/or controls solutions that promote electrical stability, electric grid

safety, and aircraft safety, and also assessed energy storage requirements. NASA in-house researchers at Glenn and Dryden are also supporting research to investigate power management and distribution challenges and issues for hybrid gas-electric propulsion concepts, including building scale bench-top or small test stands to understand the challenges of operating an electric motor and gas-turbine on the same shaft to power a fan. The promise of hybrid gas-electric concepts such as the Boeing Sugar Volt and NASA TeDP for significant reductions in fuel/energy consumption, emissions, and noise makes this an attractive area for potential greater increase in NASA research investment in the future.

III. Summary

The FW Project is making investments in propulsion research and technology development that are expected to contribute to enabling significant reduction in fuel/energy consumption of future advanced fixed wing aircraft for the 2030-2035 time frame relative to current state-of-the-art engines. The investments in propulsion and materials research presented herein are to enable: (i) smaller higher OPR engine cores for increased thermal efficiency and to increase bypass ratio for increased propulsive efficiency, (ii) robust, distortion tolerant fans for vehicle integrated boundary layer ingesting propulsion systems, and (iii) cryocooled high power density electric motors for the TurboElectric Distributed Propulsion aircraft concept. Additional investments in hybrid gas-electric propulsion technologies are expected in the near future, which will include research and technology development of non-cryocooled (ambient temperature) high power density electric motors and components. The hybrid gas-electric and turbo-electric engine concepts show promise for significant reduction in fuel/energy consumption towards achieving the emissions and noise goals of the FW project. In FY14, the project is planning to augment investments in hybrid gas-electric propulsion toward development of non-cryogenic electric motors and components.

Acknowledgments

This effort is sponsored by the FW project of the NASA Fundamental Aeronautics Program. The research described is part of the FW Propulsion Efficiency subproject portfolio. The authors greatly appreciate the accomplishments of the many researchers and technologists whose efforts have supported, and continue to support, the goals of the FW project.

References

- ¹Bradley, M., and Droney, C., "Subsonic Ultra Green Aircraft Research: Phase I Final Report," NASA CR-216847, 2011.
- ²Greitzer, E. M., et al., "N+3 Aircraft Concept Designs and Trade Studies, Final Report," NASA CR-216794/VOL1&2, 2010.
- ³Bruner, S., et al., "NASA N+3 Subsonic Fixed Wing Silent Efficient Low-Emissions Commercial Transport (SELECT) Vehicle Study," NASA CR-216798, 2010.
- ⁴D'Angelo, M., et al., "N+3 Small Commercial Efficient and Quiet Transportation for Year 2030-2035," NASA CR-216691, 2010.
- ⁵Felder, J., Kim, H., and Brown, G., "Turboelectric Distributed Propulsion Engine Cycle Analysis for Hybrid-Wing-Body Aircraft," AIAA 2009-1132, 2009.
- ⁶Ashcroft, S. W., Padron, A. S., Pascioni, K. A., Stout, G. W., Huff, D. L., "Review of Propulsion Technologies for N+3 Subsonic Vehicle Concepts," NASA TM-217239, 2011.
- ⁷NASA Research Announcement (NRA): NNH10ZEA001N, Soliciting Basic And Applied Research Proposals, Research Opportunities in Aeronautics - 2010, ROA-2010, "Understanding and Mitigating Tip Leakage and End Wall Losses in High Pressure Ratio Cores,"
URL:<http://nspires.nasaprs.com/external/viewrepositorydocument/cmdocumentid=255585/solicitationId=%7BCA9C71FC-633B-672C-D05E-A136BD2162C5%7D/viewSolicitationDocument=1/ROA%202010%20Amend5%207Feb11a.pdf> [cited 7 February 2011].
- ⁸Epstein, A., "Aeropropulsion for Commercial Aviation in the 21st Century and Research Directions Needed," AIAA 2013-0001, 51st AIAA Aerospace Sciences Meeting including the New Horizons Forum and Aerospace Exposition, Grapevine, Texas, 07 - 10 January 2013.
- ⁹Drela, M., "N+3 Aircraft Concept Designs and Trade Studies – Appendix," Technical Report NASA CR-2010-216794/VOL2, NASA, 2010.
- ¹⁰DiOrio, A., "Small Core Axial Compressors for High Efficiency Jet Aircraft," Masters Thesis submitted to the Department of Aeronautics and Astronautics, Massachusetts Institute of Technology, August 23, 2012, URL:
<http://dspace.mit.edu/bitstream/handle/1721.1/77107/825066815.pdf?sequence=1> [cited 23 August 2012].
- ¹¹Hurst, J., "Materials and Structures Research for Gas Turbine Applications Within the NASA Subsonic Fixed Wing Project," ASME paper GT2010-23177 (NASA/TM—2011-216747), Proceedings of the ASME Turbo Expo 2010, Glasgow, Scotland, United Kingdom, June 14–18, 2010.
- ¹²Delgado, I. R., Proctor, M. P., Steinetz, B. M., Flowers, J., and Oswald, J. J., "An Introduction to NASA's High Temperature,

High Speed Turbine Seal Test Facility,” NASA/TM—2006- 214371, ARL—MR—0645, July 2006.

¹³ Smith, L. H. Jr., “Wake Ingestion Propulsion Benefit,” *Journal of Propulsion And Power*, Vol. 9, No. 1, Jan.-Feb. 1993.

¹⁴ Daggett, D. L., Kawai, R., and Friedman, D., “Blended Wing Body Systems Studies: Boundary Layer Ingestion Inlets with Active Flow Control,” NASA CR-2003-212670, December 2003.

¹⁵ Plas, A.E., Sargeant, M. A., Madani, V., Crichton, D., Greitzer, E. M., Hynes, T. P., and Hall C. A. “Performance of a Boundary Layer Ingesting (BLI) Propulsion System,” 45th AIAA Aerospace Sciences Meeting, AIAA 2007-450, January 2007.

¹⁶ Kawai, R. T., Friedman, D. L., and Serrano, L., “Blended Wing Body (BWB) Boundary Layer Ingestion (BLI) Inlet Configuration and System Studies,” NASA CR-2006- 214534, December 2006.

¹⁷ Hardin, L. W., Tillman, G., Sharma, O. P., Berton, J., Arend, D. J., “Aircraft System Study of Boundary Layer Ingesting Propulsion,” AIAA 2013-3993, 48th AIAA/ASME/SAE/ASEE Joint Propulsion Conference & Exhibit, Atlanta, GA, 30 July – 01 August, 2012.

¹⁸ Florea, R., Matalanis, C., Hardin, L., Stucky, M., Shabbir, A., “Parametric Analysis and Design for Embedded Engine Inlets,” AIAA 2012-3994, 48th AIAA/ASME/SAE/ASEE Joint Propulsion Conference & Exhibit, Atlanta, GA, 30 July – 01 August, 2012.

¹⁹ Florea, R. V., Voytovych, D., Sharma, O., Tillman, G., Shabbir, A., Stucky, M., “Aerodynamic Analysis of a Boundary-Layer-Ingesting Distortion-Tolerant Fan,” GT2013-94656, Proceedings of ASME Turbo Expo 2013, San Antonio, Texas, USA, June 3-7, 2013.

²⁰ Bakhle, M. A., Reddy, T. S. R., Herrick, G. P., Shabbir, A., Florea, R. V., “Aeromechanics Analysis of a Boundary Layer Ingesting Fan,” AIAA 2012-3995, 48th AIAA/ASME/SAE/ASEE Joint Propulsion Conference & Exhibit, Atlanta, GA, 30 July - 01 August, 2012

²¹ Kim, H., Brown, G., and Felder, J., “Distributed Turboelectric Propulsion for Hybrid Wing Body Aircraft,” International Powered Lift Conference, July 22-24, 2008, URL: <https://mdao.grc.nasa.gov/publications/iplof08-kim.pdf> [cited July 2008].

²² Felder, J. L., Kim, H. D., and Brown, G. V., “Turboelectric Distributed Propulsion Engine Cycle Analysis for Hybrid-Wing-Body Aircraft,” 47th AIAA Aerospace Sciences Meeting including The New Horizons Forum and Aerospace Exposition, January 5-8, 2009, Orlando, FL, URL: <http://mdao.grc.nasa.gov/publications/AIAA-2009-1132-622.pdf> [cited 2009].

²³ Armstrong, M., Ross, C., Blackwelder, M., and Rajashekara, K., “Trade Studies for NASA N3-X Turboelectric Distributed Propulsion System Electrical Power System Architecture,” *SAE International Journal of Aerospace*, 5(2):325-336, 2012.

²⁴ Armstrong, M., Ross, C., Phillips, D., and Blackwelder, M., “Stability, Transient Response, Control, and Safety of a High-Power Electric Grid for Turboelectric Propulsion of Aircraft,” NASA CR-2013-21785, June 2013.