

13-17 July 2014, Tucson, Arizona

Z-2 Prototype Space Suit Development

Amy Ross¹ and Richard Rhodes²
NASA Johnson Space Center, Houston, TX 77058

David Graziosi³, Bobby Jones⁴, and Ryan Lee⁵,
ILC Dover, Inc., Frederica, DE 19946

Bazle Z. (Gama) Haque⁶ and John W. Gillespie Jr.⁷
University of Delaware Center for Composite Materials, Newark, DE 19716

NASA's Z-2 prototype space suit is the highest fidelity pressure garment from both hardware and systems design perspectives since the Space Shuttle Extravehicular Mobility Unit (EMU) was developed in the late 1970's. Upon completion the Z-2 will be tested in the 11 foot human-rated vacuum chamber and the Neutral Buoyancy Laboratory (NBL) at the NASA Johnson Space Center to assess the design and to determine applicability of the configuration to micro-, low- (asteroid), and planetary- (surface) gravity missions. This paper discusses the 'firsts' that the Z-2 represents. For example, the Z-2 sizes to the smallest suit scye bearing plane distance for at least the last 25 years and is being designed with the most intensive use of human models with the suit model.

Nomenclature

<i>AES</i>	=	Advanced Exploration Systems
<i>ASTM</i>	=	American Society of Testing and Materials
<i>EMU</i>	=	Extra-vehicular Mobility Unit
<i>EVA</i>	=	Extra-Vehicular Activity
<i>FSA</i>	=	Feedwater Supply Assembly
<i>ft</i>	=	foot
<i>HUT</i>	=	Hard Upper Torso
<i>ISS</i>	=	International Space Station
<i>J</i>	=	Joules
<i>NBL</i>	=	Neutral Buoyancy Laboratory
<i>PAS</i>	=	Power, Avionics, and Software
<i>PLSS</i>	=	Portable Life Support System
<i>psi</i>	=	pounds per square inch
<i>3D</i>	=	three dimensional
<i>VTD</i>	=	Vertical Trunk Diameter

¹ Advanced Pressure Garment Technology Development team lead, Crew Survival and Space Suit Systems Branch, MS EC5 2101 NASA Parkway.

² Advanced Pressure Garment Technology Development team member, Crew Survival and Space Suit Systems Branch, M/S EC5 2101 NASA Parkway.

³ Chief Engineer, ILC Houston, 2200 Space Park Drive Suite 110 Houston, TX, 77058.

⁴ Senior Designer Engineer, ILC Dover, One Moonwalker Road Frederica, DE 19946.

⁵ Senior Design Ryan Lee, ILC Houston, 2200 Space Park Drive Suite 110 Houston, TX, 77058.

⁶ Center for Composite Materials Scientist, 202 Composites Manufacturing Science, Newark, DE 19716.

⁷ Center for Composite Materials Director, 202 Composites Manufacturing Science, Newark, DE 19716.

I. Background

NASA's Advanced Exploration Systems (AES) Advanced Extra-Vehicular Activity (EVA) project is working toward a Chamber B human-rated thermal, vacuum chamber demonstration of a complete advanced Extravehicular Mobility Unit (EMU), consisting of a planetary surface walking pressure garment configuration and a portable life support system (PLSS) that utilizes new technology components. The Z-2 prototype pressure garment addresses two major steps in pressure garment maturation that are required to meet this goal: hardware fidelity and system-level interfaces. Previous pressure garment prototypes have primarily served as mobility joint system test beds. The prototypes were tested in ambient atmosphere, meaning the suits were tested using breathing air and at a delta pressure above 14.7 psia. Life support was provided by ground support equipment via an umbilical interface or by a portable backpack. The Z-2 will be tested in Johnson Space Center's 11 foot chamber, which is an 11.0 foot by 19.0 foot chamber with dual airlock compartments of 9.0 foot and 10.0 foot lengths used for human testing in a vacuum environment, and for space suit development. It features a treadmill, fall protection and the necessary support systems for reduced pressure crew operations. Test of the Z-2 in the 11 foot human-rated vacuum chamber at the Johnson Space Center requires that the suit be compatible with 100% oxygen and a hard vacuum (1×10^{-2} Torr). Although most prototype pressure garments are fabricated with materials that are oxygen and vacuum compatible, the compatibility is not documented and certified. The Z-2 design and hardware will be approved for chamber use. Additionally, the Z-2 takes steps toward incorporating EMU system-level interfaces and components. Interfaces such as integrated ventilation lines, integrated audio, purge and relief valves, and volumes reserved for the PLSS feedwater supplies are examples of interfaces that are included. However, the PLSS and display and control interfaces have not been fully defined, thereby requiring additional maturation and design changes for the Z-3 prototype that will be used in the Chamber B human-rated thermal, vacuum advanced EMU demonstration.

As a clarification, the Z-2 is not a follow-on to the Z-1. The Z-1 prototype was one of several pressure garment mobility demonstrators that contributed to the decisions NASA made regarding which mobility joints were specified in the Z-2 contract. However, the Z-3 pressure garment will be a further maturation of Z-2.

Z-2 is new technology and is still in the development stage. This paper is sometimes limited in the detail it provides because of this.

II. Introduction

This paper discusses unique aspects of the development and design of the Z-2. The Z-2 represents several 'firsts' in various aspects. The scope of advanced space suit development includes new ways of designing and manufacturing suits in addition to the new mobility joint designs and materials. New techniques and technologies are being used in the design, development, and fabrication of Z-2. Although some techniques have been used traditionally, many have been enhanced through the application of new tools and technology. Some techniques are being used for the first time. Therefore, the advancements being used in the Z-2 design process are as valuable as the prototype itself.

A. Three-dimensional (3D) Modeling, Body Scan, and Printing

The dimensions of a developmental pressure garment have traditionally been determined based on a set of critical anthropometric dimensions that include: stature, vertical trunk diameter (VTD), chest breadth, expanded chest depth, hip breadth, chest circumference, bicep circumference, inter wrist distance, inter-elbow distance, wrist-to-wall distance, knee height, crotch height, and thigh circumference. These critical dimensions alone, however, tell the designers only a small portion of the complete story about the actual size of a given person and how his or her particular anthropometry should fit inside of a suit. As a result, in previous development projects the pressure garment architecture hasn't always fit the target subject pool the way it was intended. Improved suit comfort and indexing for the subject pool was a critical goal for Z-2 to make it a higher fidelity suit system. An important step has been made toward realizing that goal through the use of 3-D body scanning and 3-D printing technology.

The strict use of anthropometric dimensions does not fully allow designers to confidently assess how a particular subject will be indexed, whether there are interference points, and how the posture of that subject in various body positions ultimately affects suit sizing. Physical measurements alone also allow for error on the part of the technician doing the measuring, variation from subject to subject in how measurements are taken, and subjectivity in interpreting the physical landmarks used to take body measurements. These shortcomings are especially clear in the use of the VTD dimension, the measurement meant to describe the vertical distance from the crotch to the mid-shoulder as shown in Figure 1. Forcing a subject to stand "shoulders back" for this measurement may provide a measurement that is actually different than a more natural standing posture. The shoulder landmark may be difficult

to determine based on the musculature of the subject, and the simple act of raising the arms dramatically changes the relative distance of the two landmarks that describe this dimension, as shown in Figure 1. In addition, this strictly vertical measurement does not address the relative fore and aft position of the shoulder relative to the crotch, an oversight that may greatly affect the overall upper body indexing of a particular subject. On previous suit designs, for example, one assumption has been that if at least 1" of space is desired between the scye bearing and closest possible contact to the physical shoulder and 0.5" is desired between the physical crotch and suit brief, one could simply add 1.5" to the linear VTD dimension as provided per the anthropometric requirement and the result would be an appropriate torso fit. However, in reality, the actual solution requires solving a much more complex problem. In addition to an assumed shoulder offset it is also critical to understand how the angle and position of the scye bearing relative to a subject's shoulder and chest geometries affect potential interference points and the general positioning of the shoulder inside of the scye bearing. To achieve a full understanding of this complex interaction, it became apparent that improved suit fit would be possible by utilizing a set of 3D manikins to represent the bounds of the anthropometric requirements around which the suit architecture could be tailored. Accordingly, an initial series of reconfigurable manikins were identified. These manikins were thought to be useful because they are pose-able in the 3D environment. The realization was quickly made, however, that their movement and positioning wasn't realistic enough to provide adequate confidence in their utility. Alternatively, engineers obtained actual body scans of subjects from the target pool, in postures relevant to suited postures, that bound the critical anthropometric dimensions in various postures and shoulder positions with the help of JSC's Anthropometry and Biomechanics Facility (ABF). These various body scans were used both to tailor the suit architecture around the defining 3D, physical anthropometries and also to evaluate how the suit would move as joints were manipulated in the virtual environment to correspond to discrete body positions.

The final step in improving the fit of the subject population was to verify the suit model by creating a full-scale 3D print of the Z-2 Hard Upper Torso (HUT), waist, and brief hardware components and performing physical fit-checks of subjects from the subject pool. To correlate predicted sizing to the actual physical fit checks, each of the subjects' body scans were first fit-checked in the 3D model, which was adjusted to predict subject VTD sizing. The physical fit-check was then performed with the predicted sizing on the actual suit subject. In performing these fit-checks engineers noted that the model-based predictions were very accurate for subjects while the 3D printed "suit" was held in the donning stand. However, when the subjects were asked to walk around inside the 3D printed hardware, the weight of the suit analog induced a slight change in the posture of the subject, which created a difference between the predicted sizing and what the subject ultimately determined to be the most comfortable torso length. As a result, the overall design of the Z-2 torso was shortened by around 0.5" to better fit the subject pool during actual suit operation. Adjusting suit architecture to this level of accuracy during the design phase would not have been possible using historical design techniques as previously described.

A secondary benefit to procuring full-scale, 3D printed suit hardware was the ability to use that hardware to verify the cycle life of joint designs. In the case of the waist joint rolling convolute the suit brief element and outer rolling convolute ring were printed using glass filled nylon, a material that enabled the hardware to be pressurized to 4.3 psi and cycled thousands of times to down select rolling convolute length and fabric and to verify the operational life cycle of the waist joint design and its associated softgoods. Although the nature of the material was such that full design pressure was not achievable, it was certainly high fidelity enough for a first-order verification of the base design. This was done at a fraction of the cost of having to produce actual rolling convolute hardware components that may have required multiple iterations prior to determining an appropriate design.

3D modeling, scanning and printing technology has greatly enhanced the ability of Z-2 suit designers to accurately configure the suit architecture to the target subject pool. This represents an enormous step in the space suit design industry where entire suits previously had to be fabricated to verify subject pool fit and function. Although the technique itself is more complex than simply assuming offsets based on linear measurements, it is far more cost and schedule effective than iterating entire suit designs, and much more practical than having to live with suit architectures that end up not being able to operate within the original design parameters.

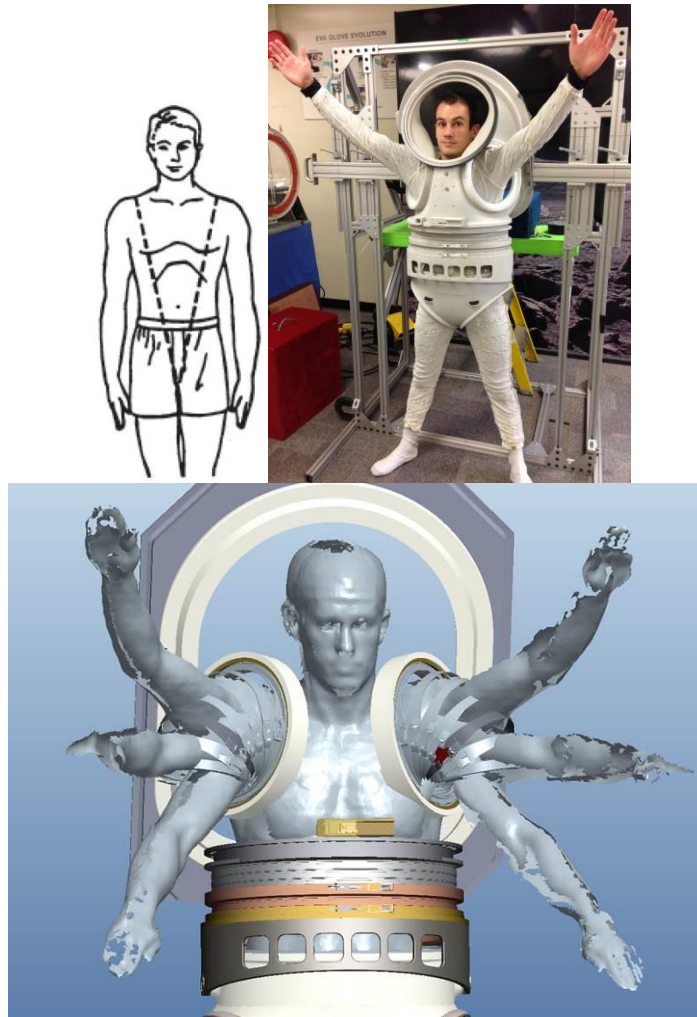

Figure 1: Fit checks with body scans and in 3-D printed components

B. Size

One pressure garment will be produced; therefore, the selection of the size of the pressure garment required careful consideration. The end customer, the astronaut office, expressed a desire to better accommodate crewmembers who are on the smaller end of the International Space Station (ISS) EMU size range, which represents a significant portion of the current crew population. It was requested that we fit crewmembers who are sized in the medium ISS EMU HUT. In addition to improved fit for the targeted size range, the team wanted to address shoulder mobility and injury prevention with the design. The scye (aka shoulder) bearing should be positioned inboard of the acromion (i.e. the bony process on the scapula that is attached to the collarbone) to better allow shoulder mobility and limit the potential for injury. When the scye bearing is inboard of the acromion, the scapula can move freely through a wider range of motion within the suit as the arm is lifted over the head before impinging on suit hardware, as shown in Figure 2. A critical anthropometric dimension associated with this fit is the biacromial distance. The related suit dimension is called the ‘Q distance,’ and is defined as the distance between the centerpoints of the innermost planes of the scye openings. The Z-2 is designed with a nominal Q distance of 11” with a sizing feature that produces a 10” Q distance. These distances are smaller than the ISS EMU planar and pivoted HUT Q distances, respectively, making the Z-2 the first EVA pressure garment to be sized that small. The rear entry design contributes to enabling smaller Q distances because, unlike a mid-body entry design, the Q distance does not have to be compromised (widened) to allow donning and doffing. Generally, rear entry designs mitigate the shoulder mobility issues associated with HUT chest depth that cause limitations to movement of the scapula. The slanted geometry of the hatch interface provides increased volume in this area allowing the scapula to move without

impinging on the hatch structure. Engineers are keeping this benefit in mind as the human-to-hatch interface is being designed.



Figure 2: Movement of shoulder

An additional goal of designing a small pressure garment was to understand the impacts to the design to achieve a good fit. The size of the pressure garment drove changes to other suit components that are valuable to discuss. In the Space Shuttle Program paradigm of modularity and reusability, the Shuttle/ISS EMU was designed to facilitate modularity. To be logistically efficient, this approach requires definition of standard bearing and disconnect diameters at various locations so that different length components can be interchanged to size the pressure garment for individual crewmembers. However, one of the prices of modularity is a compromised ability to optimally fit smaller sizes because the standard components must accept the larger sizes. In contrast, the Z-2 is being specifically designed for the small size. The following list of components had to be reduced in size from previous prototype space suit baselines to meet this goal:

- Helmet geometry: changed from the required 13” hemispherical dome to a 13” x 11” elliptical dome
- Scye bearing diameter: 0.7” smaller than Mark III
 - Note, the Z-2 scye is larger than the Shuttle EMU, which allows for better shoulder mobility
- Inter-scye sizing feature: allows reduction of the Q distance from 11” to 10”
 - Shuttle EMU planar HUT small = 11.5”; pivoted small = 10.28”
- Rolling convolute shoulder length: 1.4” shorter than Mark III
- Upper arm bearing diameter: 0.5” smaller than Shuttle EMU
- Waist brief opening width and depth: 1” smaller than Z-1 in each dimension
- Brief hip bearing diameter: 0.5” smaller than Z-1
- Hip softgoods length: 0.5” shorter than Z-1

A significant hardware change necessitated by the size of the suit was the helmet shape. One interface that is critical to maintain for modularity is the helmet neck ring. Many years of using the Mark III prototype space suit have validated the 13” hemisphere helmet for a wide variety of head anthropometries, so it was the required geometry. However, during the design process it was found that the neck ring interfered with shoulder mobility, thus mandating a change to the elliptical dome. Therefore, the baseline geometry could not be used as the suit was scaled down in size. There is some indication that the Z-2 helmet geometry will be acceptable across the full range of head anthropometries and use scenarios; however, this acceptability is not yet verified. Integrated audio as specified in the Z-2 requirements with speakers located in the hatch and microphones located on the neck ring, should not be impacted by the helmet change. The impacts will be further assessed as the Z-2 is tested.

C. Design and Analysis of Z-2 Upper Torso and Brief under Prescribed Internal Pressure Impact Loading Conditions

A composite upper torso (including hatch) and brief were proposed. The composite components of Z-2 are required to withstand a prescribed internal pressure within the limit of the allowable volumetric expansion and rate of leakage, and most importantly to withstand all possible impact loading conditions that may arise during operation under gravitational loading conditions on the lunar surface. Engineers performed an extensive modeling, validation

and analysis effort to determine the composite ply-up that would achieve the best balance of impact performance and mass reduction. The methods and tools used in the composite design are described below.

In achieving these design objectives, the University of Delaware Center for Composite Materials developed a finite element model of the Z-2 from the ProE® solid model using the combination of shell and solid elements in Hypermesh®. For static stress analyses, an all shell model was solved in NASTRAN®. For dynamic impact analysis, explicit code LS-DYNA® R7 was used. Material properties and modeling parameters for both the stress and impact analyses were determined by conducting ASTM standard tests, simulating the low velocity impact experiments on down selected composite materials, and comparing the properties with MIL-HDBK-17. Figures 3 and 4 show samples that have undergone low velocity impact testing. The materials in the figures, S-glass (improved strength E-fiberglass) and IM10 (carbon fiber), are materials being used in Z-2. Whereas maximum stress failure criteria were used for shell elements (MAT54 in LS-DYNA®), the progressive composite damage model MAT162 in LS-DYNA® was used for solid elements used in the impact zones.

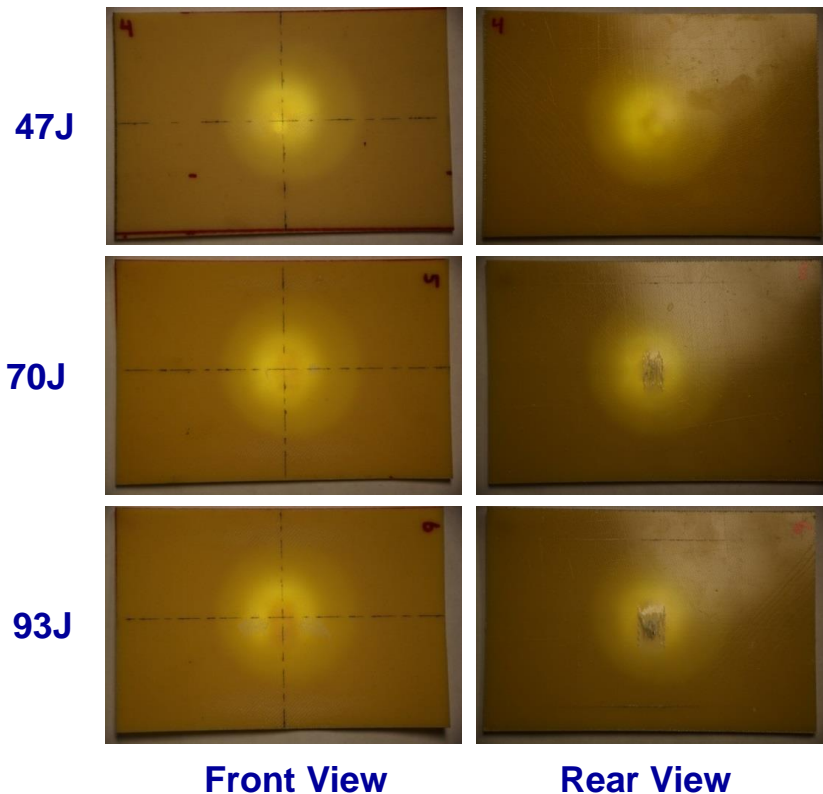

Figure 3: Low velocity impact test samples for S-Glass with impact energies in Joules (J)

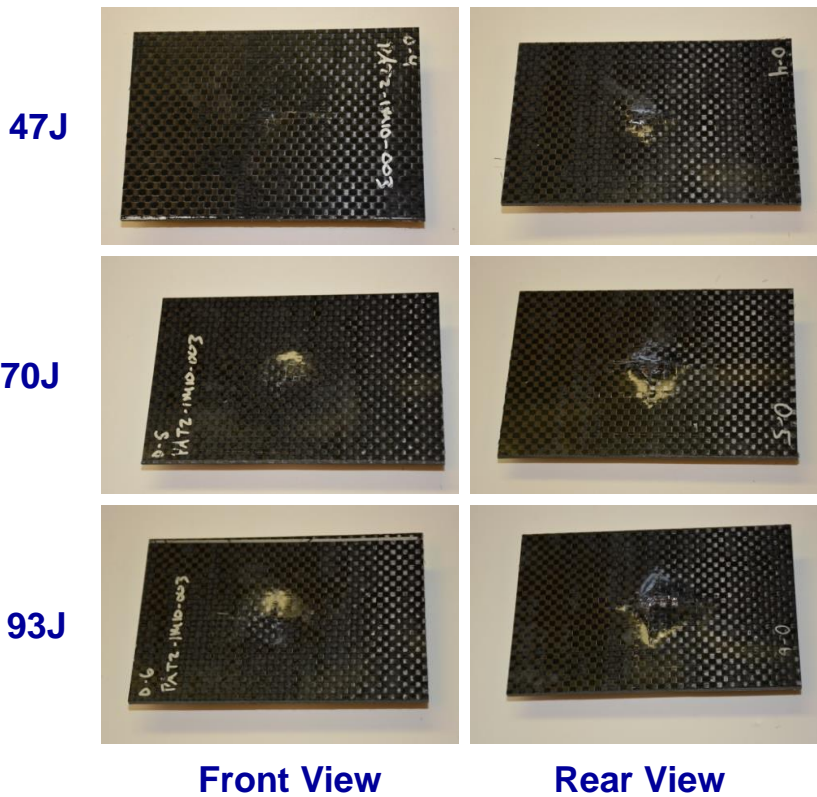

Figure 4: Low velocity impact test samples for IM-10 with impact energies in Joules (J)

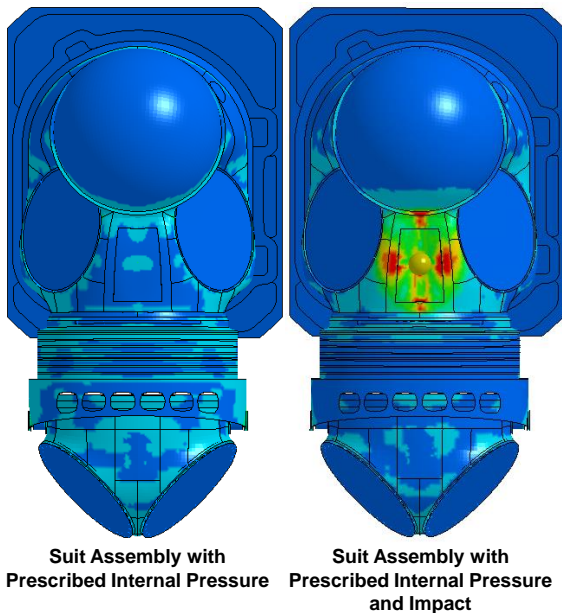

Figure 5: Arbitrary stress contours of the space suit assembly with prescribed internal pressure and impact loading conditions.

MAT162 is the state-of-the-art progressive composite damage model that can track seven different composite damage modes, i.e., fiber tension-shear and compression-shear, composite crush, in-plane and transverse matrix cracks, and delamination. Since the impact zones were modeled with solid elements, the transition between solid to shell elements were modeled using the shell-to-solid constraint option in LS-DYNA®. Contact between different components of the suit assembly and the hard impact point were modeled using LS-DYNA® automatic contact options with appropriate friction factors.

Figure 5 illustrates the finite element model of the Z-2 space suit assembly with arbitrary stress contour applied, showing the stress developed in the model under the prescribed internal pressure only and the combined internal pressure and impact loading conditions in the same scale. From the LS-DYNA® simulations, it was identified that the local stresses and deformations that arose from impact loading were an order of magnitude higher than the internal pressure only load cases. Based on the LS-DYNA® simulation results, further parametric simulations were conducted to size the composite components and to determine the stacking sequence of composite laminas to minimize the damage and deformations while satisfying the design requirements. The final design for Z-2 is a sandwich structure of S-glass and carbon fiber.

Although a variety of previous prototype pressure garments were fabricated from a range of composite materials and structures, the detailed and concerted composite modeling, validation, and analysis resulted in the most fully composite upper torso and brief structures designed to date. The design includes a minimum of metal components, such as are incorporated in the Mark III Advanced Mobility Demonstrator, for structural integrity and reinforcement.

D. Use of Titanium Bearings

Titanium and titanium alloys are highly desirable for space applications because of the material's high strength-to-density ratio. One of the many goals in development of the Z-2 is to reduce overall suit mass. During development titanium was identified as a leading candidate to enable suit weight reduction by an estimated 24 lbs. However, titanium is flammable at 100% oxygen at pressures less than 1 psia (ASTM Manual 36, p. 20). Flammability in itself doesn't eliminate titanium as a prospective material as long as all ignition mechanisms are concurrently controlled. The ignition mechanism of primary concern in the Z-2 architecture is frictional heating in the rotary bearing housings as used throughout the suit to enable low torque joint motion. As with various other components in the space suit oxygen loop that are also flammable at high oxygen concentrations and low pressures, this ignition mechanism needed be assessed if titanium was to be considered a viable bearing material. Therefore, a series of tests were conducted to evaluate the ignition potential of titanium space suit bearings during standard operations.

The Z-2 development effort does not mark the first time that titanium was identified as a potential weight saving material for space suits. A five part test series was executed in the late 1980's and early 1990's to evaluate the flammability risk of titanium bearings. Each of these tests were conducted at various pressures, rotational speeds, and operational durations under the assumption that the worst case failure was a seized steel ball within the bearing race the result of which was direct frictional sliding of steel on titanium. Specifically, the first four test phases were executed with the use of steel pins with a spherical end, sliding around a titanium gothic arch as shown in Figure 6.

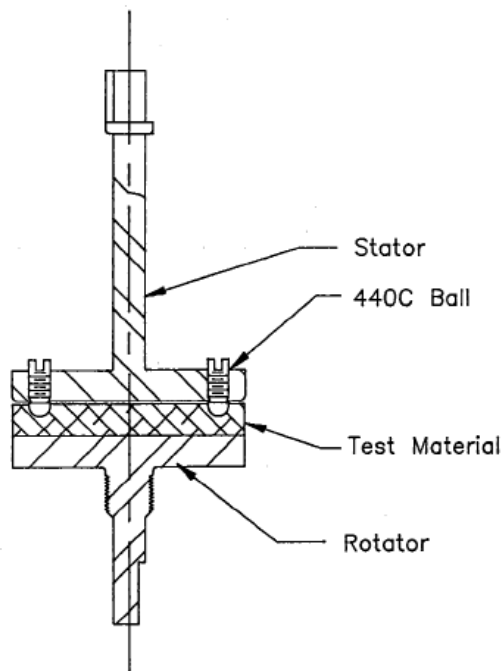

Figure 6: Gothic Arch titanium test

Each of these phases resulted in the generation of sparks, a sign that ignition could occur. The fifth phase of testing involved increasing the fidelity by spinning an actual titanium wrist bearing in which two balls had been pinned together to simulate a fused ball bearing. This phase did not result in any sparking or signs of ignition after 736 cycles, or the equivalent of two 8 hour EVAs of cycling (TR-672-001, TR-872-001). The titanium wrist bearing was not flown despite the successful wrist bearing test.

For the Z-2 development effort the failure modes observed in the first round of testing were re-visited to determine their applicability to real world suit operation. In doing so, it was determined that the worst-case failure

mode actually combines two undetectable failures and one that would be detectable and therefore fixable within a given amount of time. These failures were divided into two phases of testing. The first phase included induction of the two undetectable errors together with a bearing cycle duration equivalent to four times the expected vacuum chamber test time, or a total of 96 hours. The two “undetectable” potential modes that were tested were 1) an inner seal leak that allows the bearing race to be exposed to 100% oxygen at suit pressure, and 2) a mismatched ball port plug; a potential failure mode caused by assembly of the bearing with an incorrect ball port plug; the result of which would be either a high or low irregularity in the ball race.

The second phase of testing was limited to 30 minutes, but included the “detectable” potential failure of a failed open regulator in addition to the two previously described undetectable failures. The regulator failure scenario would elevate the suit pressure to a maximum of 10.6 psia, creating both increased oxygen pressure and plug loads at the bearings. This condition is considered to be the worst case operational scenario for a potential ignition source to exist within a titanium bearing.

There are seven different bearing locations and sizes on the Z-2 suit. Locations include the wrist, arm, scye, waist, hip, leg, and ankle. Only the bearings that are operated under the most extreme conditions were chosen to establish test case boundaries. These bearings included the waist bearing because it operates with the highest plug load, the scye bearing because it operates with the highest linear velocity based on the EMU cycle model, and the hip bearing because it operates with the highest cycle frequency based off of the high speed walking required for the Z-1 carbon dioxide washout testing. The resulting loads, cycle speeds, and rates are shown in Table 1. Using the Z-1 carbon dioxide washout testing as the bearing cycle model, required the waist and hip bearings to be cycled 195,480 times, approximately 80 times the number of cycles in the EMU waist bearing design life.

Table 1: cycle profile

Bearing	Max Velocity		Max Arc	Max Cycle Rate	Total Load	
Shoulder	135	deg/s	125 degrees	20/hr	720	lbs
	10.93 in/s				9.2 lbs/ball	
Hip	78	deg/s	45 degrees	52/min	1111	lbs
	8 in/s				7.82 lbs/ball	
Waist	52	deg/s	30 degrees	52/min	1983	lbs
	7.04 in/s				19.8 lbs/ball	

The results from White Sands Test Facility testing indicate that there is not an ignitability concern with the titanium bearings tested, but it also showed that the hip bearing profile developed for Z-2 has wear issues. No signs of ignition were seen during testing or identified in post-test inspections. This result gives the suit team the confidence to move forward with titanium bearings. This confidence is increased given that this test is very conservative because it included two simulated unidentified failures, a simulated identifiable failure, and the bearing was continued to cycle for 40 hours even after signs of substantial wear in the hip bearing appeared. The hip bearing began to show signs of wear after 100,000 cycles, which created a 4X increase in torque and substantial particulate in the bearing race, as seen in Figure 7. The wear is being investigated, and the decision to use stainless steel for the hip bearings has been made for Z-2. This amount of wear was not seen in the other bearings tested.



Figure 7: View of hip bearing torque after 100,000 cycles during flammability testing

E. Fidelity

The final aspect of the Z-2 design to be discussed is the system-level maturation. One aspect of design maturity is reflected in the handling of the Z-2 as controlled hardware. To that end, Z-2 will be delivered with oxygen and vacuum compatibility data, structural analyses, and configuration management documentation that provide rationale for safe test in a human-rated vacuum chamber. The other aspect reflecting increased system-level maturity is the interfaces to PLSS and Power, Avionics, and Software (PAS) components and to tools and ancillary items. Figure 8 shows a mock-up that was created as a feasibility study for the interfaces and that provided illustrations for the Z-2 interface requirements. Realistic system-level components and interfaces being incorporated into Z-2 are listed in Table 2. This level of integration has not been performed since the development of the Shuttle EMU. However, Z-2 does not interface to a PLSS. Those interfaces have not been defined and so are not included. The AES Advanced EVA plan is for the prototype following the Z-2, the Z-3, to be fully integrated with the PLSS and PAS system.

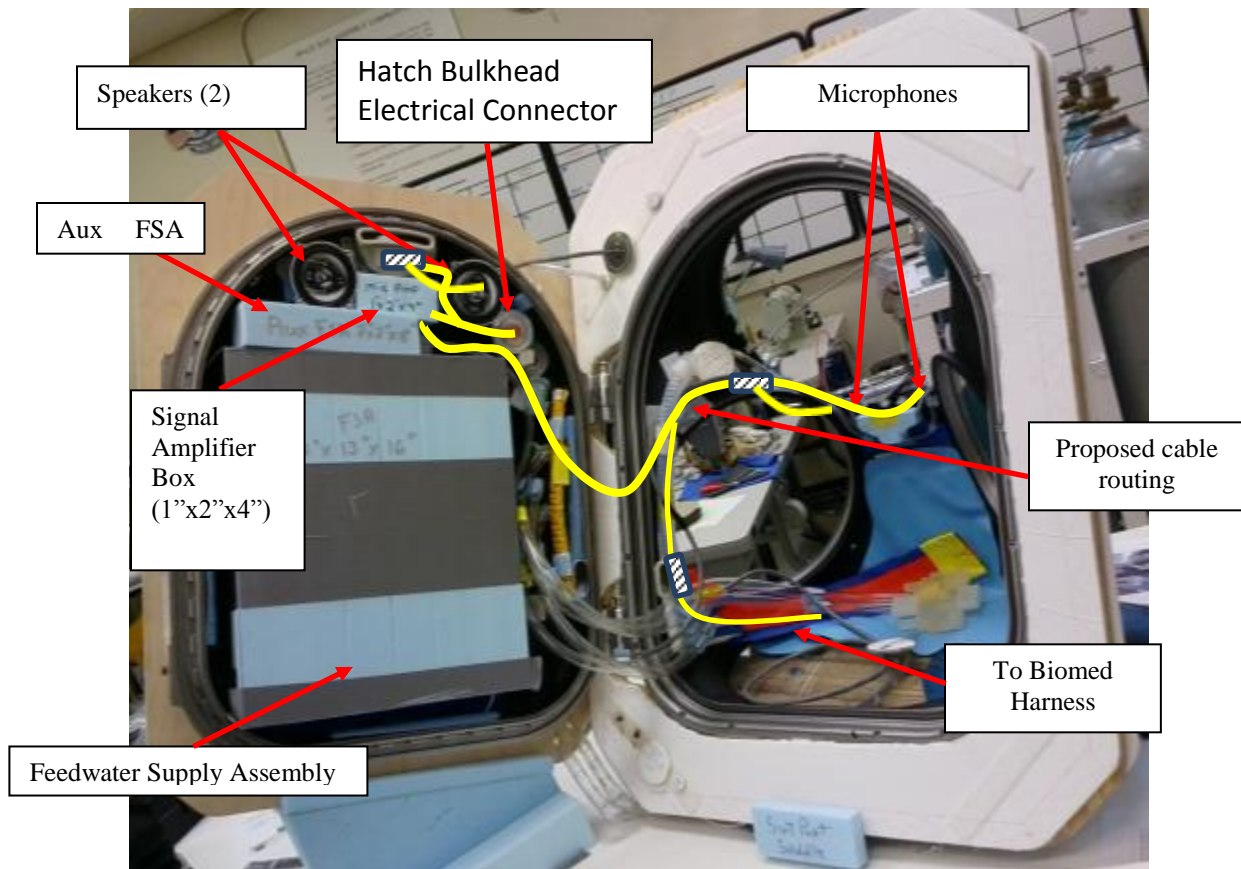

Figure 8: Examples of PLSS and PAS interfaces

Table 2: System-level interfaces included in Z-2

Component Type	Component	Notes
PLSS	Feedwater Supply Assembly (FSA)	Mounting features and volumetric keep out zone in hatch
	Auxiliary FSA	Mounting features and volumetric keep out zone in hatch

	Multi-position Suit Purge Valve	Pass-through and mounting features on HUT
	Positive Pressure Relief Valve	Pass-through and mounting features on HUT
	Return air vent interface and lines	Mounting features and hardware installed on HUT
PAS	Integrated Audio speakers	Mounting features and volumetric keep out zone in the hatch
	Integrated Audio microphone array	Mounting features and volumetric keep out zone in the HUT
	Integrated Audio signal amplifier box	Mounting features and volumetric keep out zone in the hatch
	PAS cable routing	Volumetric keep out zone in the HUT and hatch
	Display and Control Unit	Mounting features on the HUT; can also be used for NBL chest weights
Tool	Safety tether	D-ring interface on the waist
	Square boss	Multiple mounting features to locate the boss in a number of locations on the waist ring
Ancillary	In-suit drink bag	Mounting features; drink bags delivered with Z-2
	Valsalva	Volumetric keep out zone in the HUT
	Shoulder and waist harness	Included in Z-2; self-don and doffable in the HUT and brief

F. Forward Work

The Z-2 design was approved for fabrication as of March 2014 following completion of the Z-2 pre-fabrication review contractual milestone. Component fabrication is to occur from March through September. Component level assembly is planned to occur in September and suit assembly takes place in October. The suit is delivered in 2014 after the successful completion of requirement verification testing. A success-oriented schedule places chamber tests, ambient and vacuum, in April and May of 2015, respectively. Neutral Buoyancy Laboratory testing will be performed in August 2015. Subsequent ICES papers will discuss the Z-2 prototype performance and the major conclusions from testing.

III. Conclusion

The Z-2 suit development and design represent significant advancements in advanced pressure garments. A surface-specific EVA pressure garment prototype has never been designed to the level of design maturity that is represented by the Z-2. New tools and methods are being applied in the design process to achieve that maturity, which are significant achievements themselves. Additionally, the Z-2 is serving as a test bed. Z-2 is providing the opportunity to investigate the impacts of design for a smaller anthropometry range than traditionally used, and it is also allowing a first iteration assessment of system-level interfaces. As the Z-2 is fabricated and tested, it will continue to serve as a learning tool for Z-3.

Acknowledgments

The authors acknowledge the Advanced Exploration Systems (AES) program for funding the Z-2 effort.

References

- WSTF, TR-672-001. (1995). *Oxygen Compatibility of the Titanium Bearing Assembly Proposed for the ZPS Mark III Space Suit*. Las Cruces, NM: NASA.
- WSTF, TR-872-001. (1997). *Frictional Heating Testing of the Titanium Wrist Bearing Assembly for the ZPS Mark III Spacesuit Phase V*. Las Cruces, NM: NASA.