

NASA/TM-2014-218263
NESC-RP-12-00774

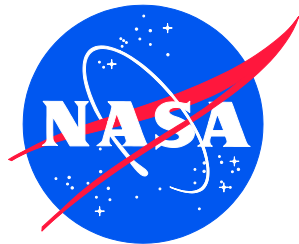

Computer-Aided Design (CAD) Tools to Support the Human Factors Design Teams

*Cynthia H. Null/NESC
Langley Research Center, Hampton, Virginia*

*Mariea Dunn Jackson, Trey Perry, Jason C. Quick, and Jack W. Stokes
Marshall Space Flight Center, Huntsville, Alabama*

NASA STI Program . . . in Profile

Since its founding, NASA has been dedicated to the advancement of aeronautics and space science. The NASA scientific and technical information (STI) program plays a key part in helping NASA maintain this important role.

The NASA STI program operates under the auspices of the Agency Chief Information Officer. It collects, organizes, provides for archiving, and disseminates NASA's STI. The NASA STI program provides access to the NASA Aeronautics and Space Database and its public interface, the NASA Technical Report Server, thus providing one of the largest collections of aeronautical and space science STI in the world. Results are published in both non-NASA channels and by NASA in the NASA STI Report Series, which includes the following report types:

- **TECHNICAL PUBLICATION.** Reports of completed research or a major significant phase of research that present the results of NASA Programs and include extensive data or theoretical analysis. Includes compilations of significant scientific and technical data and information deemed to be of continuing reference value. NASA counterpart of peer-reviewed formal professional papers, but having less stringent limitations on manuscript length and extent of graphic presentations.
- **TECHNICAL MEMORANDUM.** Scientific and technical findings that are preliminary or of specialized interest, e.g., quick release reports, working papers, and bibliographies that contain minimal annotation. Does not contain extensive analysis.
- **CONTRACTOR REPORT.** Scientific and technical findings by NASA-sponsored contractors and grantees.

- **CONFERENCE PUBLICATION.** Collected papers from scientific and technical conferences, symposia, seminars, or other meetings sponsored or co-sponsored by NASA.
- **SPECIAL PUBLICATION.** Scientific, technical, or historical information from NASA programs, projects, and missions, often concerned with subjects having substantial public interest.
- **TECHNICAL TRANSLATION.** English-language translations of foreign scientific and technical material pertinent to NASA's mission.

Specialized services also include organizing and publishing research results, distributing specialized research announcements and feeds, providing information desk and personal search support, and enabling data exchange services.

For more information about the NASA STI program, see the following:

- Access the NASA STI program home page at <http://www.sti.nasa.gov>
- E-mail your question to help@sti.nasa.gov
- Fax your question to the NASA STI Information Desk at 443-757-5803
- Phone the NASA STI Information Desk at 443-757-5802
- Write to:
STI Information Desk
NASA Center for AeroSpace Information
7115 Standard Drive
Hanover, MD 21076-1320

NASA/TM-2014-218263
NESC-RP-12-00774

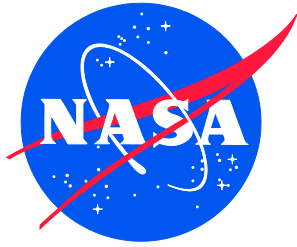

Computer-Aided Design (CAD) Tools to Support the Human Factors Design Teams

*Cynthia H. Null/NESC
Langley Research Center, Hampton, Virginia*

*Mariea Dunn Jackson, Trey Perry, Jason C. Quick, and Jack W. Stokes
Marshall Space Flight Center, Huntsville, Alabama*

National Aeronautics and
Space Administration

Langley Research Center
Hampton, Virginia 23681-2199

May 2014

Acknowledgments

The team acknowledges the assistance of Mr. Steven Gentz, NESC Chief Engineer at MSFC, for valuable guidance in completing this work. The team also acknowledges those who volunteered their time to serve as participants in the motion capture sessions.

The use of trademarks or names of manufacturers in the report is for accurate reporting and does not constitute an official endorsement, either expressed or implied, of such products or manufacturers by the National Aeronautics and Space Administration.

Available from:

NASA Center for AeroSpace Information
7115 Standard Drive
Hanover, MD 21076-1320
443-757-5802

	NASA Engineering and Safety Center Technical Assessment Report	Document #: NESC-RP- 12-00774	Version: 1.0
Title: CAD Tools to Support the Human Factors Design Teams			Page #: 1 of 142

Computer-Aided Design (CAD) Tools to Support the Human Factors Design Teams

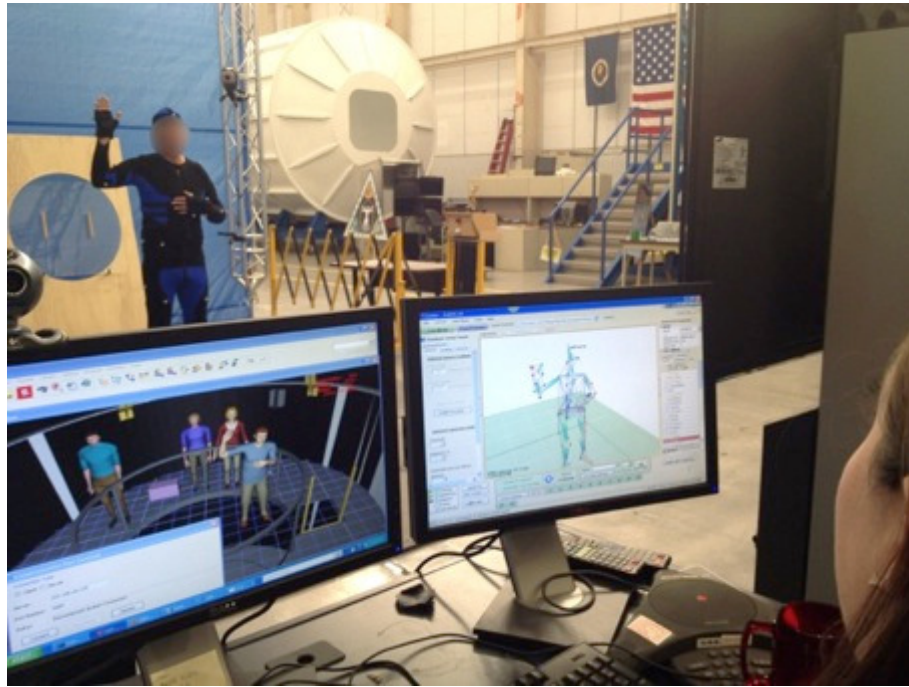

Marshall Space Flight Center Virtual Environments Laboratory

April 10, 2014

	NASA Engineering and Safety Center Technical Assessment Report	Document #: NESC-RP- 12-00774	Version: 1.0
		Title: CAD Tools to Support Human Factors Design Teams	

Report Approval and Revision History

NOTE: This document was approved at the April 10, 2014, NRB. This document was submitted to the Acting NESC Director on April 21, 2014, for configuration control.

Approved:	<i>Original Signature on File (MK)</i> <hr style="width: 80%; margin: 0 auto;"/> Acting NESC Director	<i>4/23/14</i> <hr style="width: 80%; margin: 0 auto;"/> Date
-----------	--	--

Version	Description of Revision	Office of Primary Responsibility	Effective Date
1.0	Initial Release	Dr. Cynthia Null, NASA Technical Fellow for Human Factors, ARC	4/10/2014



	NASA Engineering and Safety Center Technical Assessment Report	Document #: NESC-RP- 12-00774	Version: 1.0
Title: CAD Tools to Support Human Factors Design Teams		Page #: 3 of 142	

Table of Contents

Technical Assessment Report

1.0	Notification and Authorization	6
2.0	Signature Page	7
3.0	Team List	8
3.1	Acknowledgements	9
4.0	Executive Summary	10
4.1	Background	10
4.2	Approach.....	10
4.3	Results.....	11
4.4	Forward Work	12
5.0	Assessment Plan	13
6.0	Problem Definition, System Requirements, and Implementation	14
6.1	Problem Definition.....	14
6.2	Scope and System Features.....	15
6.3	Ground Rules and Assumptions.....	16
6.4	Operational Definitions.....	17
6.5	Technical Implementation.....	18
6.6	Motion Capture Sessions.....	21
6.7	Risk Assessment	32
7.0	Data Analysis	35
7.1	Overview	35
7.2	Database Review.....	35
7.3	Site Hosting and IT Security	36
7.4	GSDO Program Initial Baseline Work.....	37
7.5	Mockup Development.....	39
7.6	Motion Data and CAD Transferability	39
7.7	Motion Data - Processing and Playback	40
7.8	Motion Data - Calibration and Capture.....	41
7.9	Motion Data - Post-Processing.....	43
7.10	Motion Data - Observations, Issues, and Improvements	46
7.11	Motion Data - Fingers and Hands	48
7.12	Motion Data - Aligning Positions	50
7.13	Task Performance.....	50
7.14	Human Factors Analysis	52
7.15	NIOSH Lifting Limits.....	54
7.16	Database Implementation.....	54
7.17	Website Interface	55
8.0	Findings, Observations, and NESC Recommendations	56
8.1	Findings.....	56
8.2	Observations.....	57
8.3	NESC Recommendations.....	58

	NASA Engineering and Safety Center Technical Assessment Report	Document #: NESC-RP- 12-00774	Version: 1.0
		Title: CAD Tools to Support Human Factors Design Teams	

9.0	Alternate Viewpoint.....	58
10.0	Deliverables	58
11.0	Lessons Learned.....	58
12.0	Recommendations for NASA Standards and Specifications.....	59
13.0	Definition of Terms.....	59
14.0	Acronyms List	60
15.0	References.....	61
16.0	Appendices.....	62
Appendix A.	Operational Definitions.....	63
Appendix B.	Mockup Configurations and Subtask Examples	65
Appendix C.	Research Session Tools and Forms.....	68
Appendix D.	Motion Capture – User Guide and Lab Processes	80
Appendix E.	Data Organization and Naming	84
Appendix F.	NASA Program Risk Scorecard and Ratings Table.....	87
Appendix G.	Database Design Structure and Software.....	89
Appendix H.	Database Website Interface – July 31, 2013 version	97
Appendix I.	Human Research Protocol and Consent Form	102
Appendix J.	National Institute for Occupational Safety and Health (NIOSH) Lifting Equation Occupational Safety and Health Administration (OSHA).....	112
Appendix K.	Phase 2 Quick Look Test Reports.....	116

List of Figures

Figure 6.4-1.	Operational Levels Defined for Motion Capture Planning and Database Content	17
Figure 6.5-1.	Initial Mockup of Database Search Page	20
Figure 6.5-2.	Initial Mockups of Database Results Pages	21
Figure 6.5-3.	Concepts for Website Flow and Objectives.....	21
Figure 6.6-1.	Study Participant in Motion Capture Suit and Cap with Reflective Markers; Researcher taking Anthropometric Measurements.....	22
Figure 6.6-2.	Mockup and Video Configurations during Motion Capture Study at MSFC VEL.....	23
Figure 6.6-3.	Camera Mounting Structure and Workspace at MSFC VEL.....	24
Figure 6.6-4.	Vehicle Hatches, GSE Shelf and Platform, Battery LRU Mockups used during Phase 1	24
Figure 6.6-5.	Sample Mockup Configurations with Participants Performing Subtasks during Phase 1	25
Figure 6.6-6.	Progression from Solid-surface Plywood to Wireframe Steel Rod Hatch Mockups	26
Figure 6.6-7.	Phase 2 Worksite Mockup Constructed with Steel Rod and Multi-insertion Connector System.....	26
Figure 6.6-8.	Progression from Human Participant with Reflective Markers, to Motion Analysis Joint Location Data, to Steps for Cortex Software Skeleton, to Jack Software Avatar Model.....	27
Figure 6.6-9.	VEL Work Breakdown Approach	29
Figure 6.6-10.	File Naming Conventions and Folder Structure of Downloadable .zip Data Packets	31



	NASA Engineering and Safety Center Technical Assessment Report	Document #: NESC-RP-12-00774	Version: 1.0
Title: CAD Tools to Support Human Factors Design Teams		Page #: 5 of 142	

Figure 7.7-1.	Example of Creating a Motion Sequence by Combining Channelsets	41
Figure 7.8-1.	Study Participant Wearing Motion Capture Suit with Reflective Markers.....	42
Figure 7.9-1.	Participant 001 with an Average Girth and Participant 006 with a Larger Girth	44
Figure 7.11-1.	Simple VEL Schematic.....	49
Figure 7.13-1.	Participant Postures while Performing Subtasks in Phase 1	51
Figure 7.14-1.	Three Postures during LRU Transfer Subtask, Live Video, and Jack Software Animation	52
Figure 7.14-2.	Example Output from Jack Software for Low Back Analysis.....	53
Figure 7.14-3.	Example Output from Jack Software for Static Strength Prediction	53
Figure 7.16-1.	Pilot Phase PMD Topology	55
Figure 7.17-1.	Example Webpages for PMD Search, Display, and Results Pages	56

List of Tables

Table 6.5-1.	Prioritized Task List Created following June 2012 Stakeholder Workshop.....	19
Table 6.5-2.	Example Functional Breakdown based on Stakeholder Prioritized Tasks.....	19
Table 6.6-1.	Motion Segmentation and Database Fields Worksheet	30
Table 6.7-1.	Study Risk Ratings (Higher # => Greater Risk)	33
Table 7.3-1.	Options for Data Storage for 26 Gigabits	37
Table 7.9-1.	Example Task Breakdown Worksheet with Segment Times and Descriptions.....	45
Table 7.9-2.	User's Guide for Database.....	46

	NASA Engineering and Safety Center Technical Assessment Report	Document #: NESC-RP-12-00774	Version: 1.0
Title: CAD Tools to Support Human Factors Design Teams		Page #: 6 of 142	

1.0 Notification and Authorization

Dr. Cynthia Null, NASA Technical Fellow for Human Factors at the NASA Ames Research Center, was selected to lead this assessment. The task request (TI-12-00774) was approved for the Marshall Space Flight Center (MSFC) Systems Analysis Branch human factors engineering organization on April 30, 2012. Phase 1 was initiated by the MSFC contractor team in October 2012 and delivered in February 2013. Phase 2 was approved through the MSFC Technical Excellence Program in April 2013, with continuing NESC oversight. Work was initiated by the MSFC contractor team in April 2013 and delivered in September 2013.

The key stakeholders identified for this assessment are representatives from the three major human spaceflight programs, a modeling and simulation working group, and the Office of Primary Responsibility for the NASA Space Flight Human System Standard (SFHSS), NASA-STD-3001 Volume 2, and the Human Integration Design Handbook:

- Ground Systems and Operations Program: Dr. Gena Henderson, Chief, Integration Branch/System Engineering and Integration Division, Kennedy Space Center
- Space Launch Systems (SLS) Program: Ms. Sally Richardson, Human Factors Engineer, Systems Analysis Branch, MSFC
- Multi-Purpose Crew Vehicle (MPCV) Program: Ms. Susan Baggerman, Health and Medical Technical Authority, Space Life Sciences Directorate, Johnson Space Center (JSC)
- NASA Integrated Model Architecture Working Group: Mr. Joe Hale, Systems Engineer, Systems Engineering Management Office, MSFC
- NASA SFHSS, NASA-STD-3001 Volume 2, Section 13.0, ground support operations sections: Jonathan Dory, Chief, Habitability and Human Factors Branch, JSC
- MSFC Technical Excellence Program

	NASA Engineering and Safety Center Technical Assessment Report	Document #: NESC-RP- 12-00774	Version: 1.0
		Title: CAD Tools to Support Human Factors Design Teams	

3.0 Team List

Name	Discipline	Organization
Core Team		
Cynthia Null	Lead	ARC
Charles Dischinger	Deputy Lead	MSFC
Mariea Dunn Jackson	Project Lead	MSFC
Trey Perry	Simulation Engineer	MSFC
Jack Stokes	Human Factors Subject Matter Expert (SME)	MSFC
Jason Quick	Human Factors SME	MSFC
Victoria Garcia	Simulation Engineer	MSFC
Caitlyn Durham	Simulation Engineer	MSFC
Marlin Williamson	Simulation Engineer	MSFC
Advisory Board		
Tim Barth	Systems/Human Factors Engineer	Systems Engineering Office (KSC)
Barbara Kanki	Maintenance SME	ARC
Katrina Stelges	Industrial/Human Factors Engineer	United Space Alliance (KSC)
Sudhakar Rajulu	Anthropometry and Biomechanics (Physical Ergonomics) SME	JSC
Damon Stambolian	Ground Processing SME	KSC
Gena Henderson	Chief, Integration Branch/System Engineering and Integration Division	KSC
Robert Humeniuk	Simulation Engineer	KSC
Fayssal Safie	Reliability and Maintainability Engineering Technical Fellow	NASA Safety Center (NSC/MSFC)
Brad Lawrence	Motion Capture SME	United Space Alliance (KSC)
Ben Vanlear	GSE Design	GRC
Sally Richardson	Level II Systems Integration	MSFC
Chris Johansen	MTSO Program Analyst	LaRC
Administrative Support		
Diane Sarrazin	Project Coordinator	LaRC/AMA
Linda Burgess	Planning and Control Analyst	LaRC/AMA
Christina Williams	Technical Writer	LaRC/AMA

	NASA Engineering and Safety Center Technical Assessment Report	Document #: NESC-RP- 12-00774	Version: 1.0
Title: CAD Tools to Support Human Factors Design Teams		Page #: 9 of 142	

3.1 Acknowledgements

The team acknowledges the assistance of Mr. Steven Gentz, NESC Chief Engineer at MSFC, for valuable guidance in completing this work. The team also acknowledges those who volunteered their time to serve as participants in the motion capture sessions.

	NASA Engineering and Safety Center Technical Assessment Report	Document #: NESC-RP-12-00774	Version: 1.0
Title: CAD Tools to Support Human Factors Design Teams		Page #: 10 of 142	

4.0 Executive Summary

The scope of this assessment was to develop a library of basic 1-Gravity (G) human posture and motion elements used to construct complex virtual simulations of ground processing and maintenance tasks for spaceflight vehicles, including launch vehicles, crewed spacecraft, robotic spacecraft, satellites, and other payloads.

The report herein describes the task, its purpose, performance, findings, NASA Engineering and Safety Center (NESC) recommendations, and conclusions in the definition and assemblage of the postures and motions database (PMD). The primary project goal was to support the human factors design and analysis work being done on future spaceflight vehicles, ground systems, ground support equipment (GSE), and ground processing worksites.

4.1 Background

The use of computer-aided design (CAD) environment modeling, integrated with human anthropometric and performance modeling, offers assessment techniques previously lacking without the construction and maintenance of full-scale 1-G physical mockups. NASA has the potential to conserve program resources by increasing use of virtual technology for developing requirements, design concepts, and operational procedures for ground processing of spaceflight vehicles. As part of a risk mitigation exercise, the NESC requested the creation of a library of virtual human postures (e.g., body positions or poses) and simple motions for CAD-based human models for use in a worksite task evaluation [ref. 1].

Since the design, development, and ground processing of spaceflight vehicles occurs across multiple NASA centers and contractor sites, a collaborative effort was established by the NESC. Operability studies conducted by the Kennedy Space Center (KSC) Ground Systems Development and Operations (GSDO) Program defined the human activity at the element (primitive) level, with the potential for linking motion and posture elements for task procedures. A subsequent assessment conducted by the Marshall Space Flight Center (MSFC) team addressed two previously known challenges: combining human body postures or motions via stringing sequences of elements into credible chains of performance activities, and accounting for mass handled in a 1-G environment [ref. 2].

This assessment was provided with two distinct project phases and corresponding task orders. Phase 1 was funded by the NESC from October 2012 through March 2013, and Phase 2 was funded by the MSFC Technical Excellence Program from April 2013 to September 2013.

4.2 Approach

In developing the PMD, the overarching project goal was to support the human factors design and analysis work being done on future spaceflight vehicles, ground systems, GSE, and ground processing worksites. Currently, assessing tasks with digital human modeling (DHM) software can be labor-intensive and produce results that minimally account for human behaviors and

	NASA Engineering and Safety Center Technical Assessment Report	Document #: NESC-RP-12-00774	Version: 1.0
Title: CAD Tools to Support Human Factors Design Teams		Page #: 11 of 142	

anthropometric variability. The intent of the PMD database is to provide sufficient element data for a knowledgeable DHM software user to construct realistic task simulations using 5th and 95th percentile human avatars, motion capture data, and imported CAD environments of spaceflight vehicles.

The MSFC assessment was considered a pilot study in scope with data collected to prove the database concept and validate the virtual simulation technique. Function-level activities were chosen from a prioritized list generated by project stakeholders, then deconstructed to the task, subtask and element levels. Scripts were created at the subtask level and participants performed the activities by interacting with low-fidelity physical mockups while data was collected using a motion capture system. A library of motion and posture elements was developed for Jack¹ software users. The library permits searching and grouping of elements (e.g., postures or motions) that support user analysis and design. Once the desired element has been identified, the user can access the corresponding data package containing images, video, analysis, and Jack motion files to aid their design work. Linked elements can represent conceptual procedural tasks in the ground processing environment, which may result in a more effective design, development, and verification and validation approach.

The MSFC study was conducted in two phases: Phase 1 developed an operations process and initial database design, and Phase 2 refined the initial effort into a more comprehensive database. Phase 1 was successful in conducting background research and establishing processes to begin a pilot study. Emphasis was placed on defining the study scope, developing baseline operating procedures, and conducting the pilot study to obtain a representative data sample for the demonstration database. This foundational work enabled Phase 2 to refine the processes developed in Phase 1 and to focus on improving the quality and quantity of data collected. Changes in the technical approach between Phase 1 and Phase 2 are discussed in the appropriate sections.

4.3 Results

Participant trials defined capabilities of the Jack software for simulations, proved the ability to integrate CAD environments and motion data into the software virtual environment with human models (or avatars), and populated the pilot database with useful data to support design and analysis work.

The number and configuration of Virtual Environments Laboratory (VEL) motion capture cameras was sufficient to cover most motion capture needs using various mockup techniques. While plywood and polyvinyl chloride (PVC) mockups were used extensively in Phase 1, their physical surface area sometimes caused markers on the motion capture suits to become obscured

¹ Jack software is a three-dimensional (3-D) interactive ergonomics and human factors CAD package developed by the University of Pennsylvania's Center for Human Modeling and Simulation. Jack is maintained and distributed by Siemens Product Lifecycle Management Software.

	NASA Engineering and Safety Center Technical Assessment Report	Document #: NESC-RP- 12-00774	Version: 1.0
Title: CAD Tools to Support Human Factors Design Teams		Page #: 12 of 142	

from the view of near-infrared cameras. In Phase 2, it was found that using more wireframe style mockups resulted in less marker obstruction, which resulted in lower data post-processing time. Potential benefits to upgrading the VEL's current camera configuration (e.g., enabling higher resolutions and decreasing light sensitivity) are addressed in Section 7.0.

VEL personnel segmented capture session videos and three-dimensional (3-D) motion data into subtasks and elements, while experiencing challenges defining start/stop points because of participants' unique actions and transitions. Data was provided to the database design team as compressed data packets were processed and uploaded to the library.

The database website provides the ability for Jack software users to search for elements based on keywords and participant/avatar attributes. The dynamic webpages were built using the Macintosh-Apache-MySQL-PHP (MAMP) development package hosted on a MSFC server. The pilot database provided a sample of useful, generalized motion data that can be downloaded as organized data packets (.zip files). The MSFC server is accessible while on-site or through virtual private network (VPN) connection for offsite users.

4.4 Forward Work

This study provided simplified posture and motion elements and task variations and demonstrated the intended use of a motion capture database. Proposed future efforts are as follows:

- Make the database available to projects and programs for design analysis.
- Collect more data to expand the database.
- Improve the technology used in motion capture sessions to integrate hand tracking and head-mounted displays to observe manual dexterity and allow participants to experience immersion in the virtual environment.
- Integrate hand tracking and head-mounted display into motion capture sessions to observe manual dexterity, observe immersion experience, and increase simulation fidelity.

	NASA Engineering and Safety Center Technical Assessment Report	Document #: NESC-RP- 12-00774	Version: 1.0
Title: CAD Tools to Support Human Factors Design Teams		Page #: 13 of 142	

5.0 Assessment Plan

The NESC-initiated project proposed creation of a library of human postures and motion sequences that enabled realistic virtual simulations of 1-G ground processing and maintenance tasks. Based on a prioritized task list, a study was designed to capture scripted motion sequences performed by participants in an operational motion capture and human modeling laboratory. Data was to be stored in the PMD that would be available to NASA, its contractors, and commercial partners. The MSFC contractor team was to perform the task simulation sessions, database development, and report generation. The NASA civil servants provided oversight.

The majority of the assessment plan was followed based on the pilot study project scope defined by the MSFC contractor team. The effort was comprised of two phases, with Phase 1 identifying acceptable laboratory operations, realistic task simulations, data processing and database/interface design. The emphasis remained on data collection that enabled creating subtask animations linked for avatar simulations within a 3-D CAD virtual environment. Phase 2 refined the data collection and post-processing techniques. Phase 2 also provided an opportunity for additional unique task simulations, resulting in new element data collection and an expanded database library.

Differences between the study initial plan and execution represent decisions reached in coordination with the stakeholders, user community, and team members to refine the initial concept while maintaining a useful design product within program constraints. Major differences between the initial plan and execution were:

- Analysis and data collection planning in Phase 1 began 4 months later than expected because of contractual adjustments. Phase 2 started 2 months later than expected because of personnel and funding changes.
- Collaborative postures and motions creation between MSFC and KSC was minimal and consisted of feedback on initial session scripts and final stages of database development.
- The human motion data collection was limited to an amount that validated the virtual simulation techniques and database design.
- Stakeholders provided a prioritized list of functions and tasks. For the pilot study scope, representative task portions were chosen to capture a subset of high-priority activity.
- In cases where definition was not provided for KSC-specific worksites, ground processing equipment, or activities, the VEL team created low-fidelity mockup hardware of approximate dimensions based on anticipated launch vehicle configurations.
- Pre-study assessment demonstrated the need to have transparent or translucent mockups to allow the data cameras to track the test subject suit markers.

	NASA Engineering and Safety Center Technical Assessment Report	Document #: NESC-RP- 12-00774	Version: 1.0
Title: CAD Tools to Support Human Factors Design Teams		Page #: 14 of 142	

- Operational constraints for pre-launch processing activities were further captured relative to body motions (e.g., twisting, leaning, stretching, etc.) beyond what was obtained in Phase 1.
- Relatively realistic mass was introduced into some task simulations to challenge the human operator in performing pre-launch simulated motions.

6.0 Problem Definition, System Requirements, and Implementation

6.1 Problem Definition

The goal of this study was to define and create a digital library of human model postures and motion elements (i.e., primitives) that captured basic, measurable, and accurate human behavior motions. Database products should provide the capability for human factors analysts to link postures and/or motion capture sequences to simulate more complex ground processing subtasks for spaceflight vehicles. This will offer Jack software users a source of application specific human data with unique behaviors and movements and minimize the need to estimate manikin postures and motions.

The digital library was intended to be a design tool for: 1) space vehicle ground processing worksite design concepts and trades; 2) design development; 3) requirements establishment, analysis, verification, and validation; 4) safety and quality assurance assessment; and 5) real-time procedures preparation for imminent processing and maintenance tasks. As virtual human-system simulation is becoming an effective method for human factors engineering assessments, the use of CAD environment modeling, integrated with human anthropometric and performance modeling, offers techniques for capturing human behaviors previously lacking without full-scale 1-G physical mockups.

Modeling human performance is still a challenge utilizing CAD modeling techniques, even for performing simple tasks, including human body postures or motions. As previously mentioned, there are difficulties in stringing sequences of virtual postures and motions into credible chains of performance activities; and there is difficulty in accounting for mass handled in a 1-G environment [ref. 2]. However, NASA is interested in using such virtual technology to address design concepts and requirements definition, and operational procedures for ground-based spaceflight vehicles. Hence, an integrated effort was established among the NESC, KSC, Johnson Space Center (JSC), Glenn Research Center, and MSFC to create a library of elements (primitives) representing human postures and motions, which can be recognized and utilized in a CAD modeling environment. By developing libraries of common validated ground processing actions, pre-launch processing tasks can be modeled based on the library elements, offering insight to engineering, safety and quality assurance, preflight operations organizations, and program management. This use of digital design for pre-launch processing has the potential to decrease the likelihood of redesign and improve design for operability for NASA programs.

	NASA Engineering and Safety Center Technical Assessment Report	Document #: NESC-RP-12-00774	Version: 1.0
Title: CAD Tools to Support Human Factors Design Teams		Page #: 15 of 142	

6.2 Scope and System Features

This study was a two-phase pilot study supporting best practices for continued motion capture and database efforts. The study defined a database containing specific human postures and motions that can be downloaded and assembled in a “chain” to replicate a ground processing procedure. It was scoped as a pilot study for proof-of-concept only, with intentions of proving the concept of a virtual library of postures and motions.

- The primary customers and users of the PMD will be engineering/design, safety and quality assurance, and ground processing and engineering organizations.
- Data collection was conducted by MSFC using its VEL tool for collecting virtual data and transposing it into a library of human posture and motion elements.
- The PMD consisted of tabulated data of elemental postures and motions, including appropriate anthropometric data.
- Data is accessible to the user for linking (chaining) to create virtual animations of typical launch processing procedures.

Desired Features

The initial functionality desired for the PMD was based on existing NASA-hosted websites that store, search, and retrieve data. Features included:

- Front-end, web-based data interface
- Secure permission-based data entry
- Pull-down menus
- Ability to add custom text
- Links to images, documents, 3-D models, videos, and raw motion data
- Searchable user application
- Simple navigation
- Multiple data windows for comparison of human tasks, anthropometric categories, and cross-relationships
- Ability to create custom reports with imagery

	NASA Engineering and Safety Center Technical Assessment Report	Document #: NESC-RP- 12-00774	Version: 1.0
Title: CAD Tools to Support Human Factors Design Teams		Page #: 16 of 142	

6.3 Ground Rules and Assumptions

The following ground rules and assumptions were imposed for the Phase 1 and 2 study:

1. Constraints were imposed on each posture or motion when the load exposed to the human motion capture participant might exceed safe performance limits.
2. For the pilot phase, Jack software was used to create simulation data.
3. The pilot phase database was intended to support the work of designers and analysts addressing human actions in ground processing operations.
4. The motion analysis database was elemental and generic and not tied to a specific worksite environment or ground processing functions.
5. A typical pre-launch processing or maintenance task was defined by separating the activity into finite and measurable subtasks, which were reduced to strings of elements (primitives). These elements were the selectable items in the motion analysis database and can be linked in any order to create a task.
6. Participants selected for the pilot study were limited to body and limb dimensions approximating the standardized 1988 Army Anthropometric Survey (ANSUR) 5th and 95th percentile dimensions [ref. 8] as closely as possible (i.e., ± 5 percent for Phase 2).
7. The study was designed under ground rules and assumptions for lifting limits for standard tasks, to support the Ames Research Center (ARC) Human Research Institutional Review Board (IRB) recommended practices for assuring participant safety [ref. 3].
8. As a consequence of time and manpower constraints, the National Institute for Occupational Safety and Health (NIOSH) lifting equation calculations were performed using the calculations embedded in the Jack software rather than manually. The library user will need to make such calculations as their subsequent task is defined.
9. Tasks to be modeled were based on stakeholder needs as defined in a prioritized list (see Table 6.5-1). Based on stakeholder recommendations for the pilot study, typical subtasks were selected which were generic in nature and could be representative tasks for various missions. These included hatch removal and temporary restraint, hatch entry, protective cover installation/removal, electrical connector management, and line replaceable unit (LRU) installation in standing and kneeling body positions.
10. Subtask definition is enhanced if lower back analysis and static strength prediction are included.
11. Task analysis toolkit within the Jack software is used in lieu of manual NIOSH lifting equation calculations.

	NASA Engineering and Safety Center Technical Assessment Report	Document #: NESC-RP- 12-00774	Version: 1.0
		Title: CAD Tools to Support Human Factors Design Teams	

6.4 Operational Definitions

Each function encompasses a set of tasks that were segmented into a series of subtasks (motions). Subtasks were reduced to their “element” parts, which included static postures and short, basic motions as shown in Figure 6.4-1.

FUNCTION – Requested prioritized pre-launch processing activity (e.g., crew access arm ingress/egress), which contains several tasks.

TASK – Measureable portion of functional activity defined by specific beginning and end points. Characterized by definable stopping or break points. Combination of tasks is equivalent to a function, which contains several subtasks.

SUBTASK – Portion of a task which captures one or more postures or motions necessary to complete the least measurable activity portion of a task. One or more sequences of motions or postures are equivalent to and represent a subtask. Contains several posture and motion elements.

ELEMENT – A posture, motion, or combination thereof, with a start and end point recognizable by the Jack software. Definable as a single standard entity in the PMD.

PARTICIPANT – 5th percentile human female or 95th percentile human male wearing a motion analysis suit with critically placed reflective data-producing dots posing in a posture or moving in some definable and limited manner to replicate desired avatar motion. Participants are 5th percentile female or 95th percentile male in stature and reach based on the 1988 ANSUR percentile definition [ref.8].

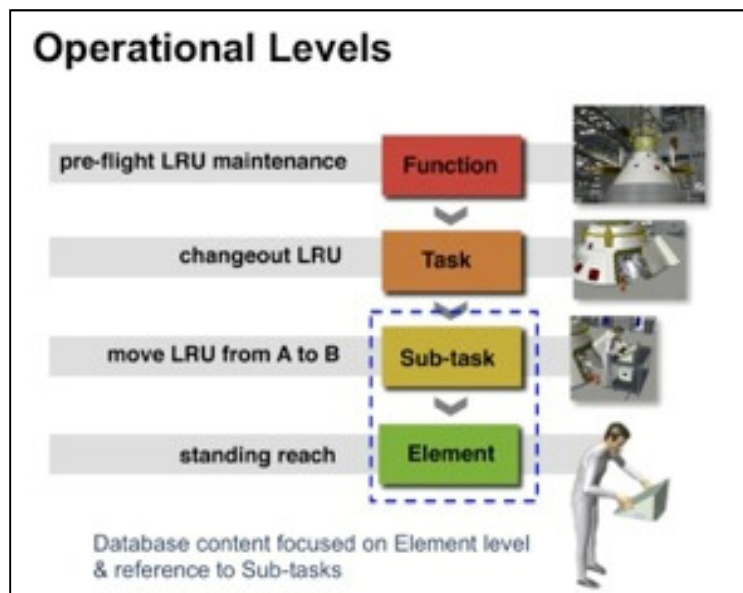



Figure 6.4-1. Operational Levels Defined for Motion Capture Planning and Database Content
(Additional operational descriptions in Appendices)

	NASA Engineering and Safety Center Technical Assessment Report	Document #: NESC-RP- 12-00774	Version: 1.0
Title: CAD Tools to Support Human Factors Design Teams		Page #: 18 of 142	

6.5 Technical Implementation

The study required three main technical capabilities: assessment of human factors guidelines and task design for study; planning, capture, and processing of motion-related participant data; and the library design, development and implementation. Extensive learning and prototyping was necessary for each capability to produce favorable results. The study approach was built on existing knowledge of ground processing tasks, VEL motion capture capabilities, and current NASA database examples with an emphasis on the experience a designer or analyst would have using the database.

Major efforts during the study included:

1. Determining the highest-priority ground processing functions and related tasks, as specified by results from the stakeholder team workshop (Table 6.5-1).
2. Defining representative subtasks found in more than one high-priority functions.
3. Designing the experiment with participant simulation script and appropriate capture facility.
4. Capturing subtasks as 3-D motion data for storage and retrieval.
5. Reducing subtasks to their elemental motions and postures.
6. Designing, building, and hosting database of elements.
7. Creating functional, intuitive webpages to provide database content.
8. Demonstrating how element database would be utilized by stakeholder community.

Function Definition

Two common function-level activities were chosen from a stakeholder prioritized list as shown in Table 6.5-1. The functions included the installation and/or removal of a typical launch vehicle access hatch and the installation of typical LRUs approximating a mass of 15 pounds with passage through the open hatch. Each function encompassed a set of tasks that were segmented into a series of subtasks (motions) as shown in Table 6.5-2. Subtasks were reduced to their “element” parts, which included static postures and short, basic motions. For relationships between function, task, subtask, and element see Figure 6.4-1 and for a more detailed description see Appendix A.



NASA Engineering and Safety Center Technical Assessment Report

Document #:
**NESC-RP-
12-00774**

Version:
1.0

Title:

CAD Tools to Support Human Factors Design Teams

Page #:
19 of 142

Table 6.5-1. Prioritized Task List Created following June 2012 Stakeholder Workshop

STRUCTURE/EQUIPMENT	TOOLS	ASSUMPTIONS
		1) Gantry walkway in place; utilities connected & activated. 2) Hatch handling GSE located near hatch worksite; tool set, hatch protection devices in place 3) Qualified workers/QA restrained w/ acceptable lighting 4) Stage motion at minimally acceptable levels (wind, etc.) 5) Worksite safety protection accommodations in place
SLS Stage 1 Hatch	GSA Item #TBD	Assumes GSE portable dolly on gantry, has lockable wheels for safety and stability.
SLS Stage 1 Hatch	GSA Item #TBD	Assumes worker will manually push GSE dolly to worksite in close proximity to stage hatch. This should require leaning to initiate motion.
SLS Stage 1 Hatch	GSA Item #TBD	Assumes wheels must be locked & inspected for lock by worker.
SLS Stage 1 Hatch	GSA Item #TBD	Assumes some preparation must be done to GSE before it is ready to accept hatch, once hatch is released.
SLS Stage 1 Hatch	Tool Set #TBD	Same assumptions as for GSE dolly.
SLS Stage 1 Hatch	Tool Set #TBD	Same assumptions as for GSE dolly.

Table 6.5-2. Example Functional Breakdown based on Stakeholder Prioritized Tasks

Original document: Task Descriptions for Motion Analysis B (version 1).xlsx

NESC MOTION ANALYSIS TASKS					
TASK	SUBTASK NUMBER	SUBTASK	HUMAN POSITIONING	SUBJECT DIMENSIONS	
				95% MALE	5% FEMALE
Position GSE & tool set at worksite	X.01.01	Move GSE from holding area to task location adjacent to hatch.	Bend with feet asymmetrical (release GSE dolly from restrained position)		
			Reach/Lean unassisted with feet asymmetrical (push GSE dolly to hatch location & position)		
	X.01.02	Secure GSE to gantry hardpoints.	Kneel (fasten GSE dolly to gantry hardpoints)		
			Lean (release GSE hatch receiver restraints to accept freed hatch)		
	X.01.03	Move tool set from holding area to task location adjacent to hatch.	Bend with feet asymmetrical (release tool set dolly from restrained position)		
			Lean unassisted with feet asymmetrical (push tool set dolly to hatch location & position)		

User Scenario and Interface Concepts

The process of assessing tasks with digital human models can be labor-intensive and produce inaccurate results. Software users are required to manually position the participant in predicted

	NASA Engineering and Safety Center Technical Assessment Report	Document #: NESC-RP-12-00774	Version: 1.0
		Title: CAD Tools to Support Human Factors Design Teams	

key postures and then direct the software to interpolate movements. It can be difficult to accurately depict motions because of human behaviors and anthropometric variability.

As envisioned, the database would be populated with element data and provide sufficient information for a knowledgeable Jack software user to manipulate 5th and 95th percentile human avatars within an imported, CAD-modeled environment of a spaceflight vehicle. The user would access the database, search for key motions and postures envisioned in the subtask, and link selected elements into subtask motions and activities. After correcting for overlaps and conflicts, the user would document the final virtual simulation of a specified ground processing operation.

Preliminary webpage mockups were created in Adobe Illustrator to communicate the site structure and user experience. Concepts identified the ability to select keywords for postures and motions, and tasks and subtasks. Human operator (i.e., study participant) characteristics could be selected to narrow searches. The results page would show thumbnail images and appropriate description of specific elements and element detail pages would provide information per element and the ability to download a data packet. Figures 6.5-1 through 6.5-3 and Appendix H show concept visuals.

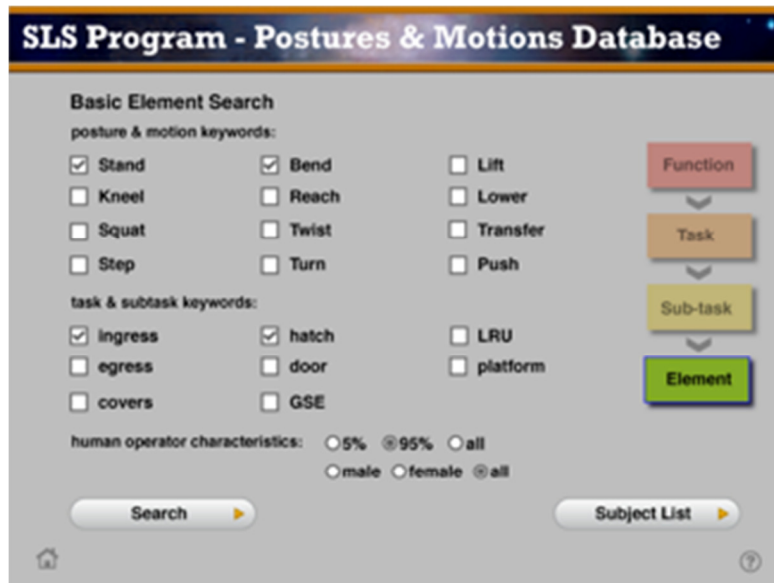

Figure 6.5-1. Initial Mockup of Database Search Page

	NASA Engineering and Safety Center Technical Assessment Report	Document #: NESC-RP-12-00774	Version: 1.0
		Title: CAD Tools to Support Human Factors Design Teams	



Figure 6.5-2. Initial Mockups of Database Results Pages

Graphical User Interface (GUI) CONCEPTS

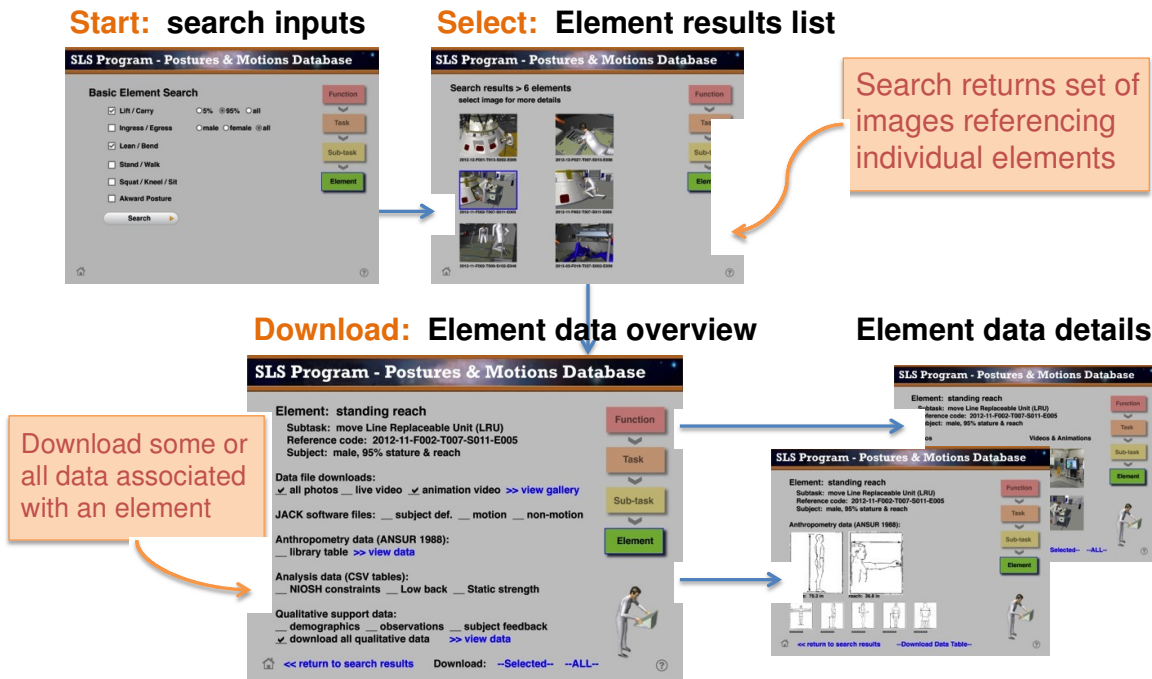



Figure 6.5-3. Concepts for Website Flow and Objectives

6.6 Motion Capture Sessions

All motion capture sessions were conducted in the MSFC VEL utilizing a combination of civil servant and contractor participants. Scripted subtask postures and motions were performed in

	NASA Engineering and Safety Center Technical Assessment Report	Document #: NESC-RP-12-00774	Version: 1.0
Title: CAD Tools to Support Human Factors Design Teams		Page #: 22 of 142	

several mockup configurations while near-infrared cameras captured the 3-D motion data. Real-time video of the participant performance and their comments were recorded.

In post-processing, the VEL team segmented data into logical elements based on natural and scripted pauses in participant motions. The database was developed for Jack software users to search for elements that support their analysis and design work and where data packages containing images, video, analysis, and Jack motion files can be downloaded.

Participants

Desired participant measurements were drawn from the 1988 ANSUR database of body dimensions to provide a representative sample that met requirements for accommodating ground operations personnel of different sizes. In Phase 1, the participant pool was a convenience sample drawn from MSFC civil servants and contractor team members: three males approximating 95th percentile in height and reach and two females approximating 5th percentile in height and reach. Recruiting was accomplished with direct invitation, team referrals, word-of-mouth, announcements in the Marshall Star newsletter, and MSFC's Knowledge Now social network. The number of participants was capped at five to meet anthropometric requirements and provide sufficient example data while allowing time for data post-processing. For Phase 2, the participant pool was drawn mostly from summer interns (contractors), with only one MSFC civil servant/contractor participant. As in Phase 1, Phase 2 limited the number of participants to five, with three 95th percentile males and two 5th percentile females. Unfortunately, because of participant and VEL team availability, one of the 5th percentile females was not able to be included in the study. Therefore, the 5th percentile female data in Phase 2 came from a single participant. An example of a participant session is shown in Figure 6.6-1.

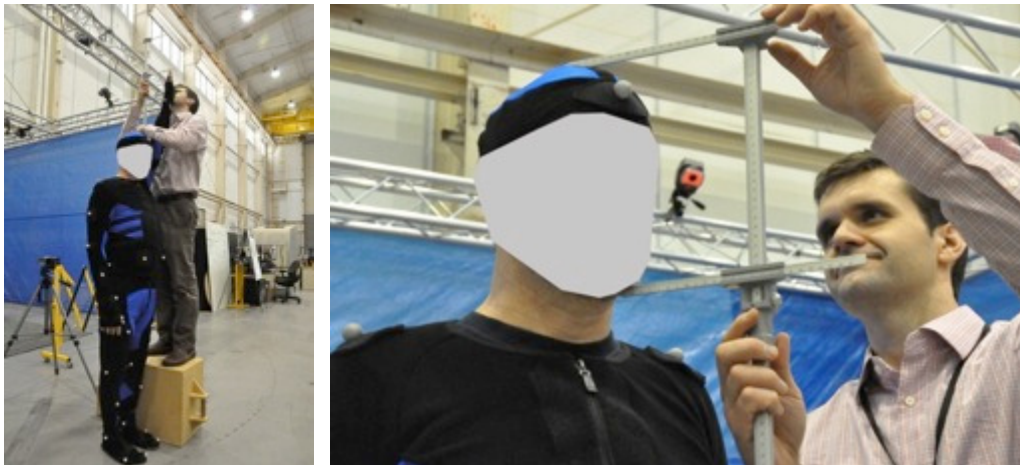



Figure 6.6-1. Study Participant in Motion Capture Suit and Cap with Reflective Markers; Researcher taking Anthropometric Measurements

Note: The participant's face is masked to retain anonymity.

	NASA Engineering and Safety Center Technical Assessment Report	Document #: NESC-RP-12-00774	Version: 1.0
Title: CAD Tools to Support Human Factors Design Teams		Page #: 23 of 142	

Study Protocol

Scripted procedures were created in compliance with the ARC Human Research IRB recommended practices. The procedures were reviewed by the MSFC Institutional Health (IH) organization to assure participant safety, health, and proper treatment during the study. Selected participants, after being assessed for appropriate physical condition and proven balance skills, were provided training for proper lifting technique as certified by the IH organization.

During capture sessions, team members positioned participant body markers and recorded participant anthropometrics. They assessed physical capabilities and existing knowledge about ground processing tasks and participants completed a demographics/work experience form. Participants with limited ground processing knowledge were provided with supplemental training on the spacecraft vehicle worksite, task goals, and additional time for rehearsing subtasks.

Participants performed the motion sequences according to scripts and were encouraged to focus on the task and subtask completion goals rather than strict methods for completion (see examples of participants during session procedures in Figures 6.6-2 through 6.6-5). The sessions were completed with participants providing subjective feedback on task comfort and research practices, which complemented the motion data and researcher observations. Participant information remained confidential and identifiable information was not provided in published data. See Appendix C for more details on session procedures.

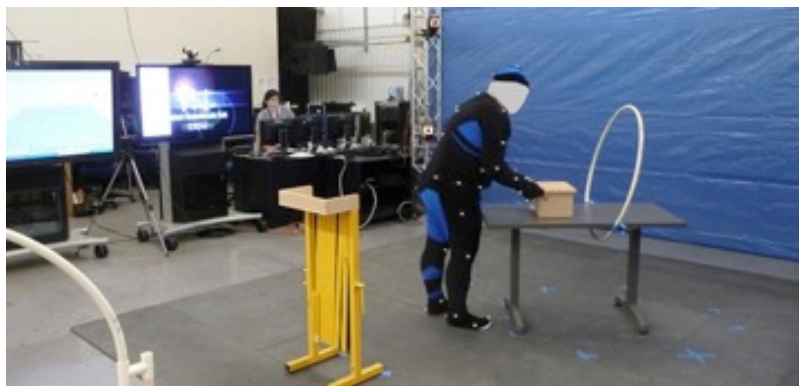

Figure 6.6-2. Mockup and Video Configurations during Motion Capture Study at MSFC VEL

Note: The participant's face is masked to retain anonymity.



NASA Engineering and Safety Center Technical Assessment Report

Document #:
**NESC-RP-
12-00774**

Version:
1.0

Title:

CAD Tools to Support Human Factors Design Teams

Page #:
24 of 142



Figure 6.6-3. Camera Mounting Structure and Workspace at MSFC VEL



Figure 6.6-4. Vehicle Hatches, GSE Shelf and Platform, Battery LRU Mockups used during Phase 1



Title:

CAD Tools to Support Human Factors Design Teams

Page #:
25 of 142

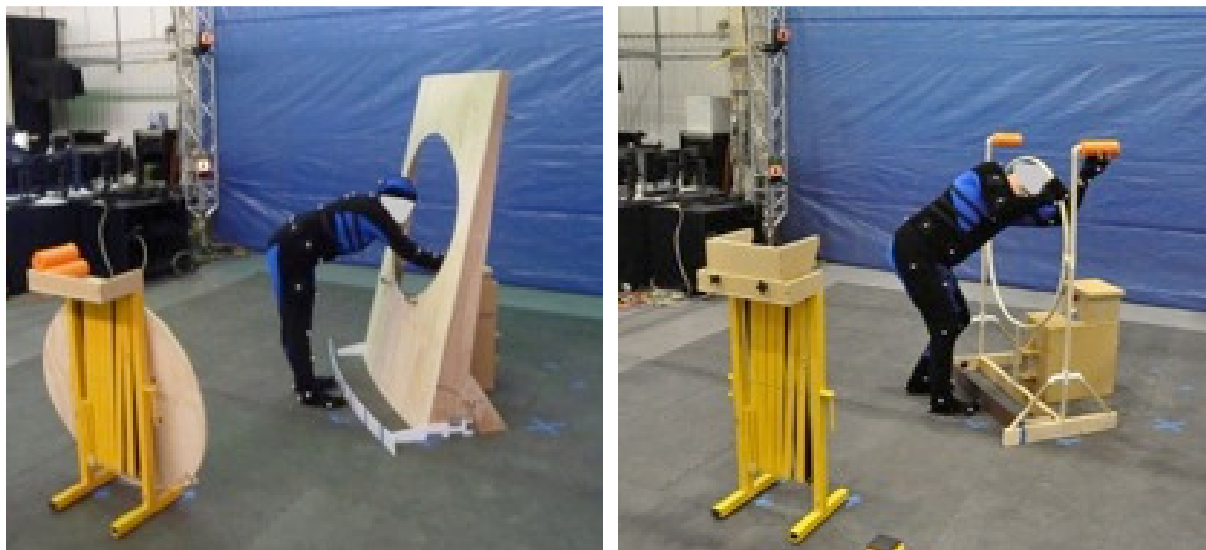

Figure 6.6-5. Sample Mockup Configurations with Participants Performing Subtasks during Phase 1

Note: The participant's face is masked to retain anonymity.

Mockup Fidelity

For Phase 1, team members created mockups of generalized vehicle hatches and GSE shelves. Phase 2 included improved fidelity versions of the Phase 1 mockups, plus additional mockups utilized for addressing increased element capture. Also included was a part-task wireframe mockup representing a segment of a launch stage that included a wireframe hatch; a connector plate with cabled connectors accessed through an access port; and protection covers over several connection locations protruding at different heights.

The environment and equipment were represented by low-fidelity mockup hardware of approximate dimensions as would typically be used for spaceflight vehicles and worksites. Pre-study assessment was restricted by the number of data cameras and demonstrated the need for transparent or wireframe mockups to adequately track the participant suit markers throughout the motion. Figures 6.6-6 and 6.6-7 show a hatch mockup progression from solid-surface plywood to transparent acrylic, to a “wireframe” PVC, and to a wireframe steel rod with custom-connector system.



**NASA Engineering and Safety Center
Technical Assessment Report**

Document #:
**NESC-RP-
12-00774**

Version:
1.0

Title:

CAD Tools to Support Human Factors Design Teams

Page #:
26 of 142

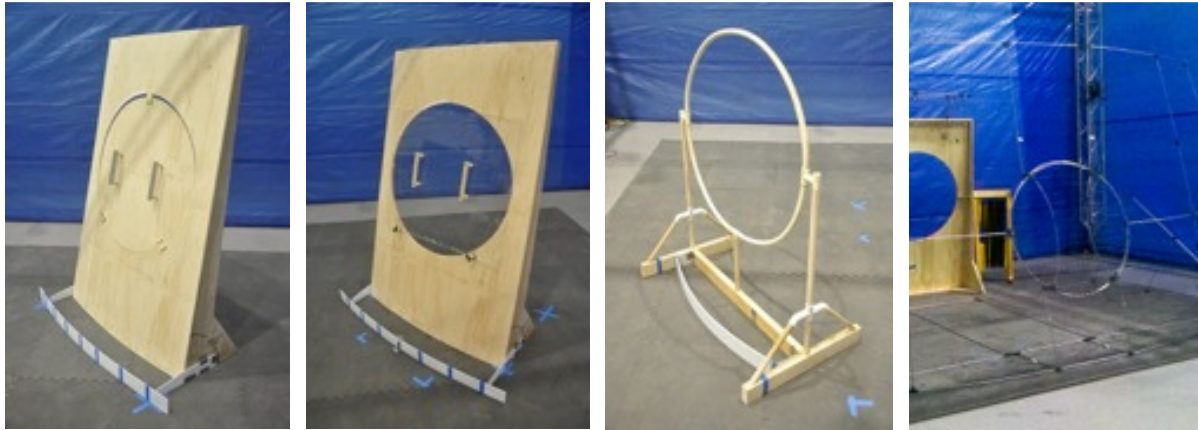

Figure 6.6-6. Progression from Solid-surface Plywood to Wireframe Steel Rod Hatch Mockups

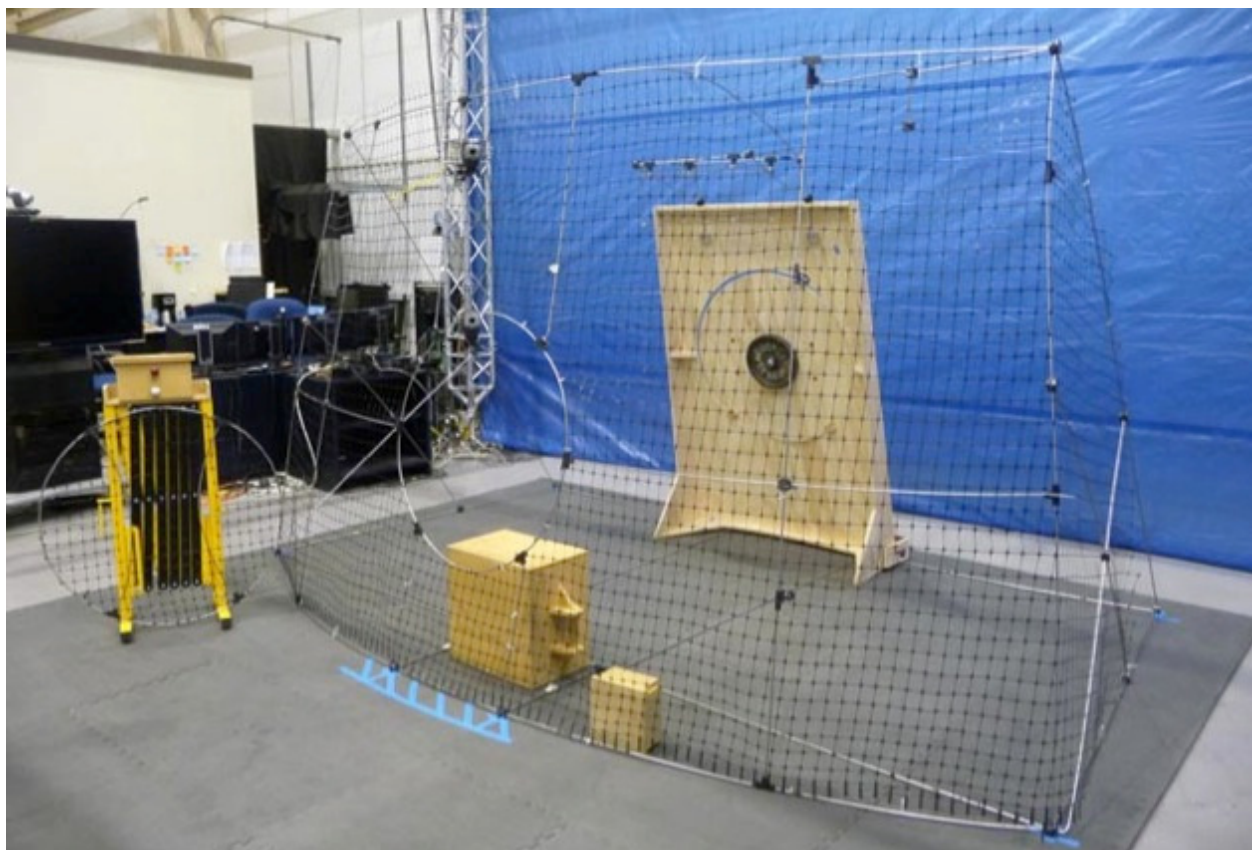



Figure 6.6-7. Phase 2 Worksite Mockup Constructed with Steel Rod and Multi-insertion Connector System

To further address the customer prioritized task list (Table 6.5-1) and expand the database with additional element creation, the Phase 2 effort generated mockups that improved the participant

	NASA Engineering and Safety Center Technical Assessment Report	Document #: NESC-RP-12-00774	Version: 1.0
Title: CAD Tools to Support Human Factors Design Teams		Page #: 27 of 142	

interactions and data capture quality. The mockups received amendments and corrections, while generic motions used in pre-launch processing indicated a need for more LRU and utility actions, including locating these units in various postures and mating/demating connectors clustered in typical limited access locations. Solid low-fidelity mockups and wireframe mockups were used to gather this new data. Extensive development of a steel rod and a multi-insertion connector system allowed the VEL team to rapidly create accurate, transparent, and customized mockups. Plastic, large-mesh netting was used to provide participants with the context of solid surfaces while allowing reflective joint markers to be tracked and unobstructed video to be captured. See Appendix B for more detailed information on mockup configuration.

VEL Motion Capture

The MSFC VEL is equipped and calibrated with 16 near-infrared motion capture cameras that track markers strategically placed on a participant's body in a 3-D space. The cameras work in conjunction with Cortex software. This software is primarily used for motion tracking and creating templates that define a human or prop. Software for Interactive Musculoskeletal Modeling (SIMM) is an add-on to the Cortex software that creates a skeleton based on the human marker data, and calculated skeleton bone are used for human factors engineering analysis. Jack software was used to record the motion channelsets of avatars from the Cortex software (Figure 6.6-8). Details are provided in Appendix D.

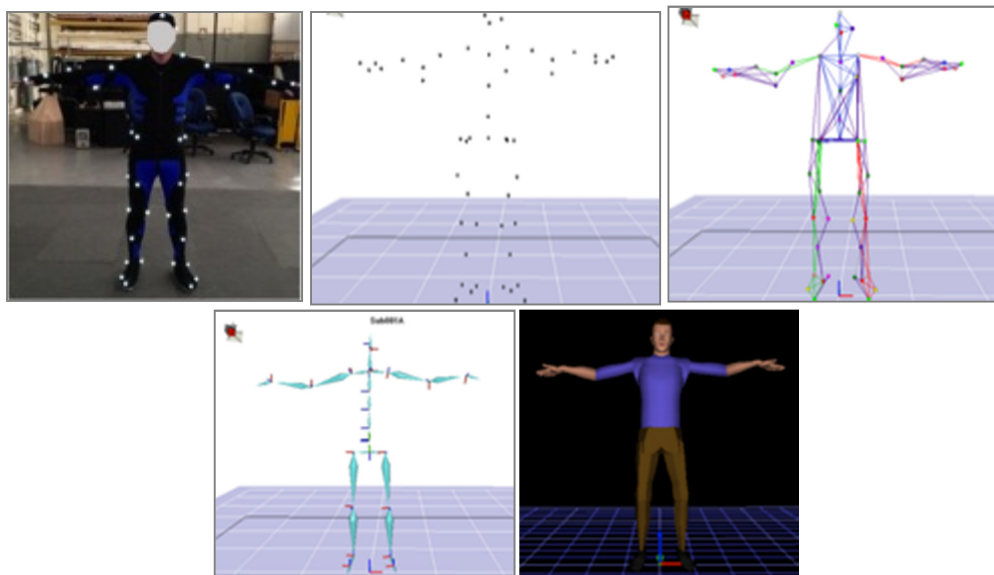



Figure 6.6-8. Progression from Human Participant with Reflective Markers, to Motion Analysis Joint Location Data, to Steps for Cortex Software Skeleton, to Jack Software Avatar Model

Two high-definition video cameras and supporting software programs were used in the study. Prior to the PMD study, the capabilities of VEL focused mainly on a body in 3-D space. The

	NASA Engineering and Safety Center Technical Assessment Report	Document #: NESC-RP- 12-00774	Version: 1.0
Title: CAD Tools to Support Human Factors Design Teams		Page #: 28 of 142	

purpose of most motion recording sessions in Phase 1 was to create templates for a specific participant, not for playback of recorded motions. During Phase 2, a new template process was used where a default template, created from a single detailed range of motion (ROM) capture, was applied to all participants using a tool in the Cortex software that adjusted the template to fit each participant individually. This study required a significant effort to develop best practices for creating motion playbacks with recorded data in DHM software. See Appendix D for additional details.

Figure 6.6-9 shows a work breakdown of the approach to creating data necessary for the PMD. The work breakdown scope included the activities directly associated with motion capture recording and Jack software outputs. Work activities not included in the figure include anthropometric measurements, suit fitting/reflective marker application, task introductions, briefing, consent forms, safety procedures, questionnaires, demographics records, live pictures, and debriefing. Activities outlined in Figure 6.6-9 are described in Section 7.0.

	NASA Engineering and Safety Center Technical Assessment Report	Document #: NESC-RP-12-00774	Version: 1.0
Title: CAD Tools to Support Human Factors Design Teams		Page #: 29 of 142	

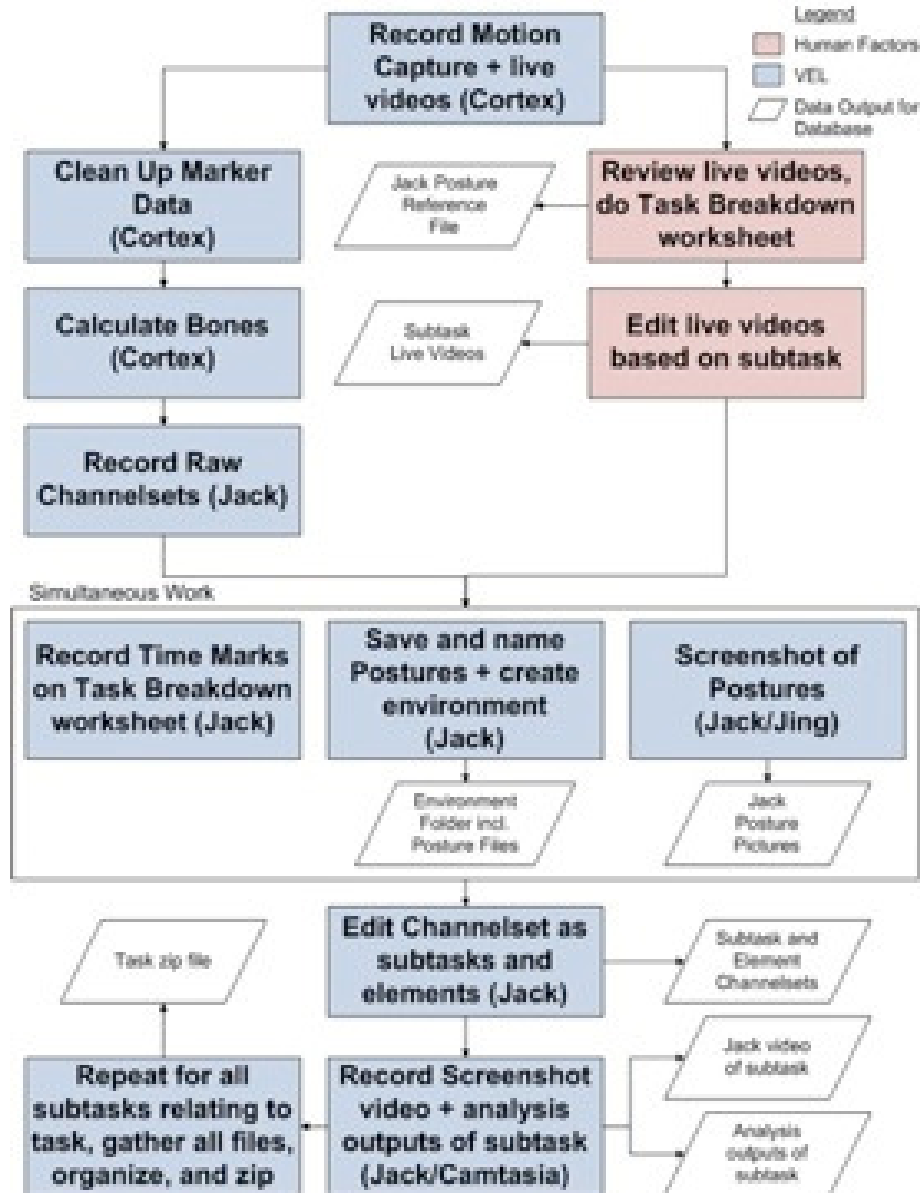

Figure 6.6-9. VEL Work Breakdown Approach

Data Planning and Organization

The organization of data file types include file nomenclature, folder structure guided capture session planning, database design, data processing, and database population. Table 6.6-1 shows the master spreadsheet used to coordinate between team members responsible for human factors, experiment design, data processing, and database design. See Appendix E for additional spreadsheet details and Appendix B for subtask examples.



NASA Engineering and Safety Center Technical Assessment Report

Document #:
**NESC-RP-
12-00774**

Version:
1.0

Title:

CAD Tools to Support Human Factors Design Teams

Page #:
30 of 142

Table 6.6-1. Motion Segmentation and Database Fields Worksheet

Element file name (postures)	Element (these are also search keywords)	Subtask	Task
sub-005-hatch-02-01a.post	stand, step, bend	remove door, hatch to shelf	attach/remove hatch from stage wall
sub-005-hatch-02-01b.post	stand, bend, reach	remove door, hatch to shelf	attach/remove hatch from stage wall
sub-005-hatch-02-01c.post	stand, bend, lift	remove door, hatch to shelf	attach/remove hatch from stage wall
sub-005-hatch-02-01a.post	stand, transfer	remove door, hatch to shelf	attach/remove hatch from stage wall
sub-005-hatch-02-01c.post	stand, bend, lower	remove door, hatch to shelf	attach/remove hatch from stage wall
sub-005-LRU-01-01a.post	stand, lift	install LRU, shelf to hatch	remove/replace LRU, location inside hatch
sub-005-LRU-01-01b.post	stand, turn, transfer	install LRU, shelf to hatch	remove/replace LRU, location inside hatch
sub-005-LRU-01-01c.post	bend, reach, lower	install LRU, shelf to hatch	remove/replace LRU, location inside hatch
sub-005-LRU-01-02a.post	bend, stand	remove LRU, hatch to shelf	remove/replace LRU, location inside hatch
sub-005-LRU-01-02b.post	bend, reach, lift	remove LRU, hatch to shelf	remove/replace LRU, location inside hatch
sub-005-LRU-01-02c.post	stand, lower	remove LRU, hatch to shelf	remove/replace LRU, location inside hatch
sub-005-hatch-02-02a.post	bend, lift	install door, shelf to hatch	attach/remove hatch from stage wall
sub-005-hatch-02-02b.post	stand, transfer	install door, shelf to hatch	attach/remove hatch from stage wall
sub-005-hatch-02-02c.post	bend, lower	install door, shelf to hatch	attach/remove hatch from stage wall
	bend, stand	install door, shelf to hatch	attach/remove hatch from stage wall

Motion capture data, video, and supporting data were processed, organized into folders, and shared as compressed (zipped) files for database inclusion, as shown in Figure 6.6-10. From the PMD, Jack software users can access the zipped files associated with a task, which include four folders for each subtask. A Media folder houses reference images, while the library analysis material is located in the Data folder. The Environment folder contains environment files from which channelset motions can be assembled into a virtual simulation. Posture files are preloaded in the Environment folder. The Jack figure resides in the Environment folder and can be opened with associated postures linked for task assessments.

	NASA Engineering and Safety Center Technical Assessment Report	Document #: NESC-RP-12-00774	Version: 1.0
Title: CAD Tools to Support Human Factors Design Teams		Page #: 31 of 142	

Task-Level Data Packets

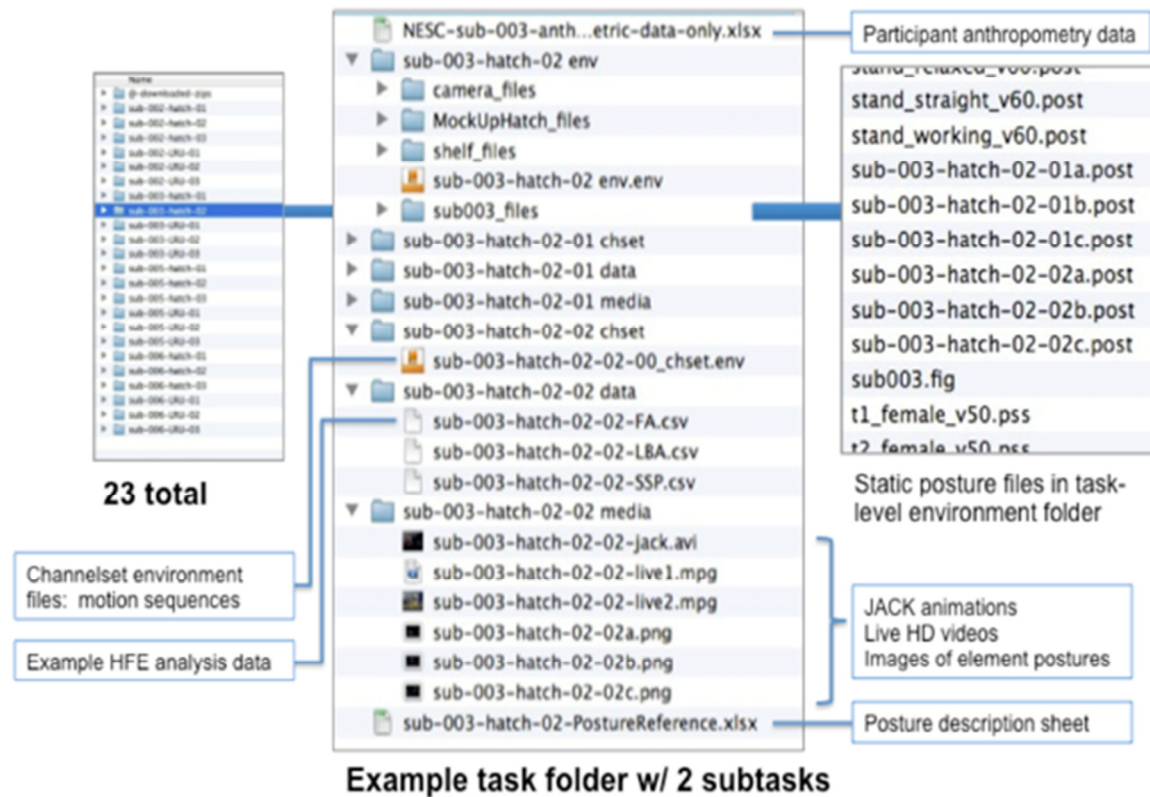



Figure 6.6-10. File Naming Conventions and Folder Structure of Downloadable .zip Data Packets

Database Design and Development

The team explored search and download techniques that would make the various types of data easily understood and retrievable by the user. Emphasis was placed on supporting the users with an intuitive, functional database.

Reference lists that show entered functions, tasks, and subtasks may be found on the corresponding pages on the PMD website. The element page contains a list of all elements and their respective task and subtask. This page is where Jack software users are able to download the compressed packets. The search page allows users to perform keyword searches using combinations of tasks, subtasks, specific postures and motions, and anthropometric constraints. Finally, the anthropometric page serves as a reference list for participant anthropometric measurements and contains descriptions of the different anthropometric measurements of concern based on the 1988 ANSUR study.

	NASA Engineering and Safety Center Technical Assessment Report	Document #: NESC-RP-12-00774	Version: 1.0
Title: CAD Tools to Support Human Factors Design Teams		Page #: 32 of 142	

See Appendix G for additional technical details on database structure and Section 7.0 for additional webpage design details.

6.7 Risk Assessment

There are potentially inherent risks in performing any simulations using human test subjects. Additionally, potential for failure can occur in the simulation and data collection design relative to desired and purported goals and accomplishments. This section assesses risk relative to defining realistic elements for virtual procedures assembly, and credible PMD elements capable of being assembled into meaningful spaceflight vehicle ground operations.

The design and operational risks inherent in this study were assessed according to the NASA Program Risk Scoreboard.

Risks during this study included:

- A. Having realistic and useful motion capture data in the database (LR-1, meaning level of risk rated as 1).
- B. Defining measureable and specific motions and postures to a database user (LR-2).
- C. Delivering a database that is accessible and user-friendly (LR-5).
- D. Providing a set of data to: develop concepts, assess safety and quality assurance designs; serve as a human factors engineering tool; and provide sufficient detail to create and modify defined operations (LR-2).
- E. Study design that is protective of study participants (LR-1).
- F. Processed data that is “clean” and accurately represents the realistic and useful motion data captured (LR-2).

By applying the NASA Program Risk Scoreboard to this study, the following was determined. No combination of risk likelihood and consequences could reach a conclusion that any of the identified risks would invalidate the simulation or adversely impact the avatar element data within the PMD. Items A, B, D, E, and F carried to a worst-case consequence of “5” will only reach a cautionary “yellow” rating, indicating minor impact to program operations or critical hardware. This is based on likelihood of occurrence while recognizing consequences. However, item C likelihood risk was deemed significantly higher, with a rating of “4” for a likelihood of occurrence and a “4” as the consequence impact producing a combined rating of 23 thereby placing it potentially in the red zone. The worst-case combination could result in the user community not being able to access and utilize the program in a timely manner, thereby impacting their program milestones. Though current plans permit users outside the MSFC firewall to access the database, it will require significant user coordination, approval, and certification. An alternate solution to improve study risk is to create a public domain server (virtual or physical) available through a formal process to dedicated government and contractor users within the restrictions of NASA Information Technology (IT) security.

	NASA Engineering and Safety Center Technical Assessment Report	Document #: NESC-RP- 12-00774	Version: 1.0
		Title: CAD Tools to Support Human Factors Design Teams	

6.7.1 Detailed Risk Descriptions and Mitigation Results

The NASA Program Risk Scoreboard was applied resulting in the assessment ratings shown in Table 6.7-1 (see Appendix F for NASA Program Risk Scorecard and Ratings Table).

Table 6.7-1. Study Risk Ratings (Higher # => Greater Risk)

A	Useful Motion Capture Data	LR-1	L/C: 1/5 = 12 (Y)
B	Measureable and Specific Motions and Postures	LR-2	L/C: 2/4 = 14 (Y)
C	User-Friendly and Accessible Database	LR-5	L/C: 5/4 = 23 (R)
D	Program Design Supportive Data	LR-2	L/C: 2/5 = 17 (Y)
E	Study Participant Protections	LR-1	L/C: 1/5 = 12 (Y)
F	Clean Post-Processed Data	LR-2	L/C: 2/4 = 14 (Y)

A. Useful Motion Capture Data - Data Storage and Hosting Capabilities

Minimal likelihood; highly significant consequences – Proven VEL expertise in human capture and modeling capabilities and creative data-gathering techniques.

- Challenge is converting physical mockup session data with human subtask actions into virtual, elemental avatar motions and postures. Successful demonstration was accomplished.
- Challenge is the ability to link motion elements and separating subtask performance into elements. Successful demonstration was accomplished.

B. Measureable and Specific Motions and Postures

Low risk likelihood; significant consequences – Human factors expertise utilizing 1988 ANSU anthropometric data as a standard and successfully finding test participants in close approximate range assured data was directly applicable to launch processing population.

- Care taken in selecting closely approximate 5th and 95th percentile male and participants.
- Element-level data collected met study protocol constraints (e.g., NIOSH, etc.) was generalizable for pre-launch processing worksite procedure generation; including participant safety concerns.
- Functional PMD is usable by users meeting stakeholder requirements.

C. User-Friendly and Accessible Database

High likelihood; significant consequences – Concern with providing pilot study data to users in accordance with NASA IT security requirements.

	NASA Engineering and Safety Center Technical Assessment Report	Document #: NESC-RP-12-00774	Version: 1.0
Title: CAD Tools to Support Human Factors Design Teams		Page #: 34 of 142	

- PMD is available to users in a MSFC restricted database and meets stakeholder funding and schedule requirements.
- Issue with accessing data by external user in accordance with NASA IT security constraints.
- ‘Consequences’ rating is less than the maximum since qualified NASA IT security personnel can manually provide data to an approved external user.

D. Program Design Supportive Data

Low likelihood; significant consequences – PMD data when linked demonstrates the capability of creating subtask-level virtual activities with an avatar.

- The VEL team demonstrated the concept of chaining elements, though refinement is needed to clear momentary breaks in the sequent elements.
- Users who understand the chaining techniques can combine the elements in the database. Such assembled activities can be used in the design spectrum beginning with design concept and progressing through verification to pre-launch spaceflight vehicle processing. The technique can be used to develop concepts, assess safety and quality assurance designs; serve as a human factors engineering tool; and provide sufficient detail to create and modify defined operations.
- The less than optimal risk rating was due to the data collected under a pilot study and significantly more database elements are needed for the database to reach its full potential.

E. Study Participant Protections

Minimal likelihood; highly significant consequences – Study was controlled from its beginning to meet Occupational Safety and Health Agency (OSHA) and NASA test subject restrictions within the study operational constraints.

- Participant physiological concerns were defined with concerns about non-standard postures and movements, including moving weighted mockups.
- Study operations protocol was approved by MSFC IH organization per IRB requirements as being acceptable for motion requirements.

F. Clean Post-Processed Data

Low likelihood; significant consequences – Final post-processed data should be “clean” (i.e., as few errors as possible) and the recorded motions should mirror the participant motions. Unclean data threatens the PMD integrity and introduces additional cost by adding additional post-process time and/or needing to perform another capture for the motion in question.

- Video footage of participant sessions was retained to validate final post-processed data.
- In Phase 2, a default template was used for participants that vastly reduced the chance of “unclean” data because of an improper ROM capture during template creation.

	NASA Engineering and Safety Center Technical Assessment Report	Document #: NESC-RP-12-00774	Version: 1.0
Title: CAD Tools to Support Human Factors Design Teams		Page #: 35 of 142	

- In Phase 2, research was conducted on the default marker set used during motion capture sessions and improvements were made in problem areas (e.g., hand and head tracking).
- Phase 2 employed post-processing techniques not performed in Phase 1, which allowed VEL operators to smooth shaky markers and to fill in gaps in marker data due to obstructions and/or un-identification.

7.0 Data Analysis

7.1 Overview

Five trials with the five participants produced significant Phase 1 results including: defining capabilities of the Jack model for simulations; and the ability to combine CAD models and environments from Pro/ENGINEER into the Jack virtual environment with human models. Ten sessions in Phase 2 provided additional unique task motions to expand the database.

The 16 data cameras in the VEL provided useful data during the pilot study, especially as mockups progressed from solid surfaces to open PVC structures and wireframe structures. However, more and/or upgraded (i.e., not light sensitive and higher resolution) cameras are needed with high-fidelity mockups to provide appropriate context for tasks. Stakeholders and VEL team members recommended a need for transparent and solid higher fidelity mockups. In Phase 2, wireframe mockups with steel rod and custom-designed connectors were developed to provide rapid fabrication capabilities, clean motion tracking, and more realistic context of the physical worksite for study participants.

For initial participants, detailed video review by human factors SMEs provided segmentation to define start/stop points for each motion. VEL teammates created corresponding subtasks and elements from the 3-D motion data and processed video and motion data for subsequent participants. The segmentation proved challenging with variability in participant body movements and transitions between motions, but resolving these issues provided opportunities for team member collaboration.

The PMD provides a sample of useful, generalized motion data. An ability to manipulate pilot study avatars will be necessary as Jack software users make corrections in hand/arm locations, widths, and mass lifting relative to simulate specific tasks and handled hardware. To support those new simulations, the VEL team needed to know the anticipated LRU dimensions and masses for the MPCV and the SLS launch vehicle.

7.2 Database Review

In the early learning and exploration phase, research on existing databases highlighted potentially useful features and limitations. The University of Michigan Center for Ergonomics has an accomplished Human Motion Simulation group that offers access to their data. However, while they have information on motion files and documentation for each experiment, they do not

	NASA Engineering and Safety Center Technical Assessment Report	Document #: NESC-RP-12-00774	Version: 1.0
Title: CAD Tools to Support Human Factors Design Teams		Page #: 36 of 142	

have an organized database that could be analyzed for search techniques or data storage methods to support the PMD design.

Internal to NASA, the NASA Imagery Reporting Database was a recent example of a simple search interface for a large amount of data and much of the page layout, data display, and site flow were applicable to the PMD. However, after an extended effort to gain access to the source files, the PMD team decided to build a new, simple database to avoid complications with code that would need to be modified or removed.

Additional projects and websites that could be reviewed during future efforts include:

- Resources for the entertainment industry (e.g., Mixamo <http://www.mixamo.com/motions>)
- University-hosted databases (e.g., Carnegie Mellon’s <http://mocap.cs.cmu.edu/>)
- Government-sponsored projects (e.g., Virtual Soldier Research <http://www.ccad.uiowa.edu/vsr/>)

7.3 Site Hosting and IT Security

Methods for organizing, storing, hosting, and accessing data were researched to provide simple, intuitive PMD access. NASA-shared, MSFC, and internal team servers and cloud network services were compared for cost, ease of support, and time to implement. Existing databases and hosting services were studied for desired functionality and technical implementation requirements. Table 7.3-1 shows the estimates provided for a November 2012 project status [ref. 4].

	NASA Engineering and Safety Center Technical Assessment Report	Document #: NESC-RP- 12-00774	Version: 1.0
		Title: CAD Tools to Support Human Factors Design Teams	

Table 7.3-1. Options for Data Storage for 26 Gigabits

Public Cloud Based Storage

Storage	\$11,893/yr	
Admin	\$7,000/yr	
Total	\$18,893/yr	\$1,574/month

MSFC Hosted Approach

Storage	\$13,621/yr	
Admin	\$7,000/yr	
Total	\$20,621/yr	\$1,719/month

Local Server in EV74

Storage	\$500 (one time hardware upgrade)	
Admin	\$8,000/yr 80 hrs at est. \$100/hr	
Total	\$8,000/yr + \$500 (one time) \$667/month	

Following these estimates, the team pursued funding for MSFC server space to host an Agency-accessible database that utilizes an authentication system developed by the database team to validate approved user access. This proved immediately challenging because of program constraints and was not resolved during the pilot phase. To optimize project results and maximize team member contributions creating the database, the requirements for database hosting were limited to an MSFC server that was only accessible inside the Center security firewall (i.e., onsite users). Access to the database from off-site is possible using MSFC VPN access.

For future work, the PMD security plan is the Distributed Engineering Collaborative Information System CD-9999-M-MSF-2722 (i.e., ITSP 2722). See Appendix G for additional technical information on the software tools used and the underlying database structure.

7.4 GSDO Program Initial Baseline Work

The GSDO Program initiated a timeline analysis to improve the processing flow of ground systems-interfacing spacecraft, including the Orion MPCV spacecraft and SLS. To develop the analysis, it was determined human activity must be defined at the element (primitive) level to create processing functions from functional subtask segments. An initial effort produced in the KSC Human Engineering Modeling and Performance (HEMAP) group analyzed a series of typical human body motions and postures useful for defining virtual human motion via avatar

	NASA Engineering and Safety Center Technical Assessment Report	Document #: NESC-RP-12-00774	Version: 1.0
Title: CAD Tools to Support Human Factors Design Teams		Page #: 38 of 142	

technology. These were generic and not tied to specific ground processing tasks. It was determined, through further research defining ground processing-typical motion elements, a library could be assembled which would permit virtual modeling of typical ground crew operations, including technicians, engineers, quality inspectors, and safety personnel. By utilizing the MSFC VEL, it was determined the NESC could provide a reliable and realistic family of motions and postures. These data, when linked by a designer, could define in detail a conceptual or advanced fidelity worker-vehicle process, permitting myriad of ground assembly, maintenance, inspection, test and checkout, and troubleshooting operations.

Work completed by the HEMAP group was assessed and augmented for this effort. Hence, serving as the initial baseline; previous studies provided beginning groundwork for virtual simulations using avatars to assess and depict pre-launch operations. The KSC study emphasized defining elements and the current MSFC effort subsequently provided elements that can be chained to create ground operation sequences for stakeholders. Products from the KSC studies were utilized as a foundation for the MSFC study for experimental design, task procedure definition, and human motion and modeling expertise. Risk and safety concerns from previous studies were integrated into this pilot study. Images and perceptual information provided context for building relevant motion capture sequences.

The motions and postures identified in the KSC HEMAP study as essential in this study included:

1. Leaning
2. Reaching to various angles
3. Lifting up to 44 pounds to various heights
4. Squatting
5. Squatting while holding weighted object
6. Bending to various angles
7. Bending while holding weighted object
8. Kneeling
9. Kneeling while holding weighted object
10. Lying down on stomach, side, and back
11. Installing/removing object in combination with identified motions and postures
12. Walking
13. Walking while holding weighted object
14. Stepping up, down, and/or over
15. Climbing

The tasks simulated for motion capture represented as many of these as reasonably possible.

	NASA Engineering and Safety Center Technical Assessment Report	Document #: NESC-RP-12-00774	Version: 1.0
Title: CAD Tools to Support Human Factors Design Teams		Page #: 39 of 142	

7.5 Mockup Development

The VEL transitioned from primarily plywood and PVC mockups in Phase 1 to customizable wireframe mockups in Phase 2. In 6 to 8 weeks, the design and fabrication team developed a cutting station for steel rod structural elements; modeled, procured, and fabricated two types of multi-insertion connectors and constructed several customizable iterations of launch vehicle worksite mockups.

Simulated surfaces were achieved with plastic, large-mesh netting attached to wireframe mockup structures. This provided benefits to VEL efficiencies. First, there were significant improvements in documenting participant movements. Near-infrared camera line-of-sight to reflective joint markers was not obstructed by plywood mockup surfaces and digital video captured motion sequences that occurred outside and inside a simulated volume. Further testing is required to determine if the steel rod reflective surfaces caused issues with accurate marker tracking. Second, the mesh surfaces provided realistic context of the physical worksite and perceived visual obstructions for study participants. Further studies could assess the effect on realistic task performance. With sufficient camera coverage, small solid mockups might be used for motion capture. However, only minimum success is anticipated for simulated worksites with increasing complexity. Some obstruction of reflective anatomical markers must be expected from the data collection system. For this simulation to be useful there must be some level of low-fidelity physical mockups to provide an interfacing volume and mass and also handheld objects providing additional context for critiquing a worksite design concept. Finally, the mesh surface treatment is a low-cost, lightweight material that can be rapidly attached, modified, and removed, as mockup volumes need to be installed, updated, transported, and stored.

7.6 Motion Data and CAD Transferability

The KSC HEMAP team completed an assessment showing that the two human simulation-based software best used in conjunction with motion tracking are Jack and DELMIA software [ref. 6]. Since VEL operated only Jack software at the time of this study, the focus of this effort was on the capability of using motions and postures within Jack environment.

There are two primary, interrelated ways the MSFC team managed the file formats and motion capture software used for the database. First, the decision was made to not use the C3D file format because it requires strict naming and organization of support files, or extensive manual editing of internal names embedded in the C3D file to function properly in the Jack software. The C3D format is considered a standard for the 3-D motion capture industry and is supported by major companies that perform biomechanics, animation, and gait analysis [ref. 5]. However, it was found to be an inconsistent standard between two different VEL software programs and these constraints were not conducive to the adaptability needed for a pilot study. In several file tests with Siemens technical support, the VEL team was unable to efficiently transfer compatible C3D files from Cortex to Jack software. There were some success in implementing C3D files to Jack with extensive manual C3D file editing and the use of the Siemens-supplied environment specifically configured for C3D files. Even though DELMIA and Jack may “technically” use

	NASA Engineering and Safety Center Technical Assessment Report	Document #: NESC-RP-12-00774	Version: 1.0
Title: CAD Tools to Support Human Factors Design Teams		Page #: 40 of 142	

C3D format, the difficulty of implementing C3D files in the Jack software did not justify using a common file format shared by two (or more) human modeling software programs.

These C3D constraints relate directly to the second limit on scope. The pilot database is populated with motion capture data intended for Jack software. The marker placement on participants and the corresponding bones template can be optimized for Jack, DELMIA, or other DHM software. Jack software is the DHM application used by the MSFC team and the KSC HEMAP group, so optimizing for the Jack software was seen as the lowest impact to demonstrate the PMD concept in the available timeframe. However, some stakeholders use DELMIA or Pro/ENGINEER[®] software and would need to collaborate with Jack software users, or purchase the software to utilize the PMD. In the future, improvements to the C3D format, translation or bone calculation methods, or marker placement templates could allow the VEL-directed database to support Agency DHM users. Within MSFC, there is an internal database of raw recorded motions that were edited and translated into Jack motion and posture files. For future continuation of this database task, the internal database would need to be assessed for the ability to reuse the raw files to produce motion and posture files optimized for DELMIA and/or Pro/ENGINEER[®].

7.7 Motion Data - Processing and Playback

Motions were recorded through Jack software with a motion capture module that connects to the Cortex software (Figure 7.7-1). An avatar can be assigned to the skeleton created in the Cortex software. When a recorded motion with a calculated skeleton is played in the Cortex software, the Jack avatar moves simultaneously. The avatar motion can be recorded through the Jack software as a “channelset” file. The Jack software add-on module has an animation window where users can load channelsets and assign an avatar. Users can clip a channelset to make new, shorter channelsets that contain only the desired motions. The ease of creating, editing, and loading channelsets makes this approach preferable over using the C3D format.



Title:

CAD Tools to Support Human Factors Design Teams

Page #:
41 of 142

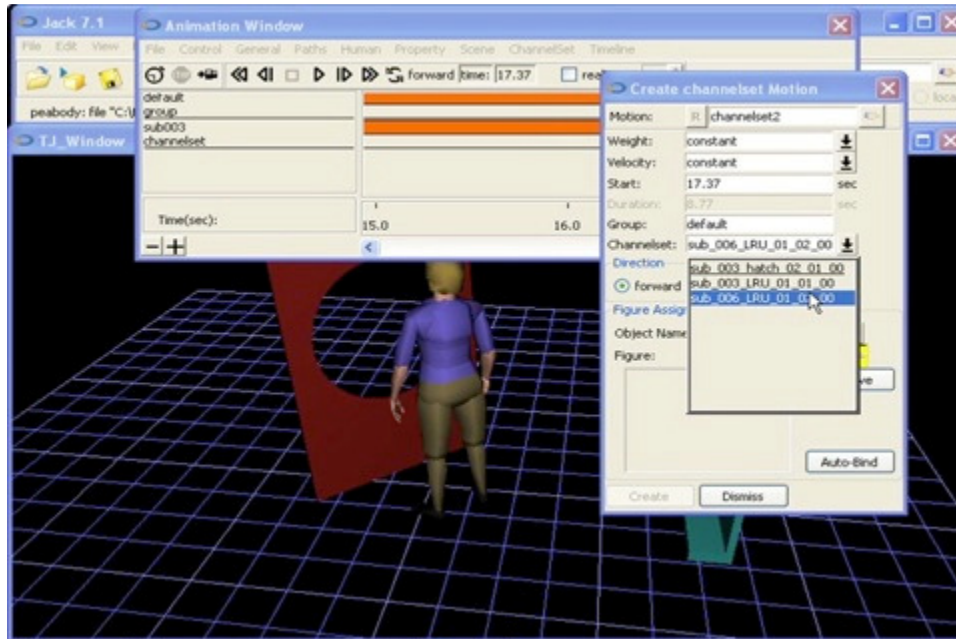

Figure 7.7-1. Example of Creating a Motion Sequence by Combining Channelsets

7.8 Motion Data - Calibration and Capture

All motion capture recordings start with the calibration of the 16-camera system to ensure the highest degree of accuracy and minimizing the number of incorrectly identified markers (i.e., ghost markers). Participants change into a suit and markers are placed on the suit based on the pre-determined locations. In the current marker-set, there were 53 markers that must be carefully placed on the participant's body to ensure they were aligned with the anatomical location to increase the accuracy of the avatar's fit to the participant's body. Figure 7.8-1 shows the marker locations.



	NASA Engineering and Safety Center Technical Assessment Report	Document #: NESC-RP-12-00774	Version: 1.0
Title: CAD Tools to Support Human Factors Design Teams		Page #: 42 of 142	



Figure 7.8-1. Study Participant Wearing Motion Capture Suit with Reflective Markers

For every new participant, several actions must be accomplished to complete a successful motion capture session. First, the participant is recorded doing a still T-Pose. This recording allows the Cortex software to calculate the skeleton bones and adjust the avatar size. The skeleton bones must be calculated because the Jack software utilizes only the skeleton bone motion and not the suit markers. Every recording starts and ends with a T-Pose, which is required for proper marker identification and gives the VEL team defined start and stop points for each recording.

The second type of recording is ROM, which are necessary for template creation. The participant performs simple ROM to “teach” the software their unique motion capabilities/ranges. ROM include wrists rotation, ankles rotation, hip rotation, leg rotation, head rotation, squat, twist, bending over, walking around, and jumping jacks. In Phase 1, each new participant would perform a ROM capture and have a template created from that capture. Phase 2 utilized a single template for all participants created from a single detailed ROM capture. This was possible by using a tool within the Cortex software called “New Subject” which takes a T-Pose capture and resizes the default template to fit that specific participant. This allowed the

	NASA Engineering and Safety Center Technical Assessment Report	Document #: NESC-RP- 12-00774	Version: 1.0
Title: CAD Tools to Support Human Factors Design Teams		Page #: 43 of 142	

VEL team to save time in the “start-up” phase for each participant and required less time before each session to get motion capture sessions setup. ROM recordings are not required to produce data, but were necessary for template creation. Through the use of templates, the motion capture software was able to better identify markers and generate improved skeleton structures. This resulted in a lower post-process time for the VEL team and allowed focus on other aspects of the motion capture sessions.

The third type of recording was task demonstration. Unlike the recordings of T-Pose and ROM, PMD task recordings were live recorded by digital cameras. Repeat recordings can be made of the same task/subtask if deemed necessary by the VEL team (e.g., bad motion capture data or task uncertainty by the participant). All live and motion capture recordings are retained for data and record keeping purposes. Because a motion capture session can include any mix of tasks/subtasks, file naming of motion capture recordings are at the VEL operator’s discretion. The session logs and database documentation contain the recording date, order of recordings (for comparison with live motion recordings), Cortex motion file names, and a detailed motion description for all recordings.

7.9 Motion Data – Post-Processing

VEL operators clean up marker data for useable motion capture recordings to ensure the captured motion data is as close to the participant motions as possible. PMD task data is often messy because of mockup interfering with marker tracking, or because specific motions or postures covering up certain markers at points during the capture. Post-process cleanup allows VEL operators to manually smooth marker shaking and to fill gaps in marker data. Marker data clean up can take a significant amount of time, requiring a day or two for each motion capture recording session. Each participant has multiple usable motion capture recording sessions, translating to a baseline estimate of between 1 to 2 weeks to clean up data per participant.

After the data clean up, skeleton bones are calculated. Theoretically, the bones should adjust to the participant size. However, calculating bones for larger girth/hip participants proved problematic because markers representing the anterior superior iliac spine anatomical landmarks were significantly offset from the actual landmark. When the hipbones are calculated, the software assumes the bones should be closer to the front of the person, thus causing the spine to artificially angle. Figure 7.9-1 shows a comparison between participants with average and large girths. At project completion, the team was consulting with Motion Analysis Corporation, the company that produces the cameras and Cortex software, to resolve this issue. Other issues found during the skeleton calculation process can usually be found in the hand and head areas. The skeleton calculation software sometimes has difficulty determining the length of certain body segments, which can result in a deformed skeleton structure. The end result of these skeleton deformations can occasionally cause the Jack software to animate the avatar in a jerky manner, cause the arms and hands to be angled, and makes the back or head pop in an unusual fashion. At this point, the skeleton definitions used were those provided to the VEL by the Motion Analysis Corporation. To edit these definitions to solve problems or generate proprietary

	NASA Engineering and Safety Center Technical Assessment Report	Document #: NESC-RP-12-00774	Version: 1.0
Title: CAD Tools to Support Human Factors Design Teams		Page #: 44 of 142	

skeleton definitions, an additional software module, SIMM, would need to be purchased. After calculation of the bones, VEL operators produce Jack channelsets of the raw recordings from the Cortex software. A channelset is a type of motion recording that can be played in the Jack software. The raw recordings capture the entire motion capture sessions and can be separated into subtask channelsets, element postures, and element channelsets.

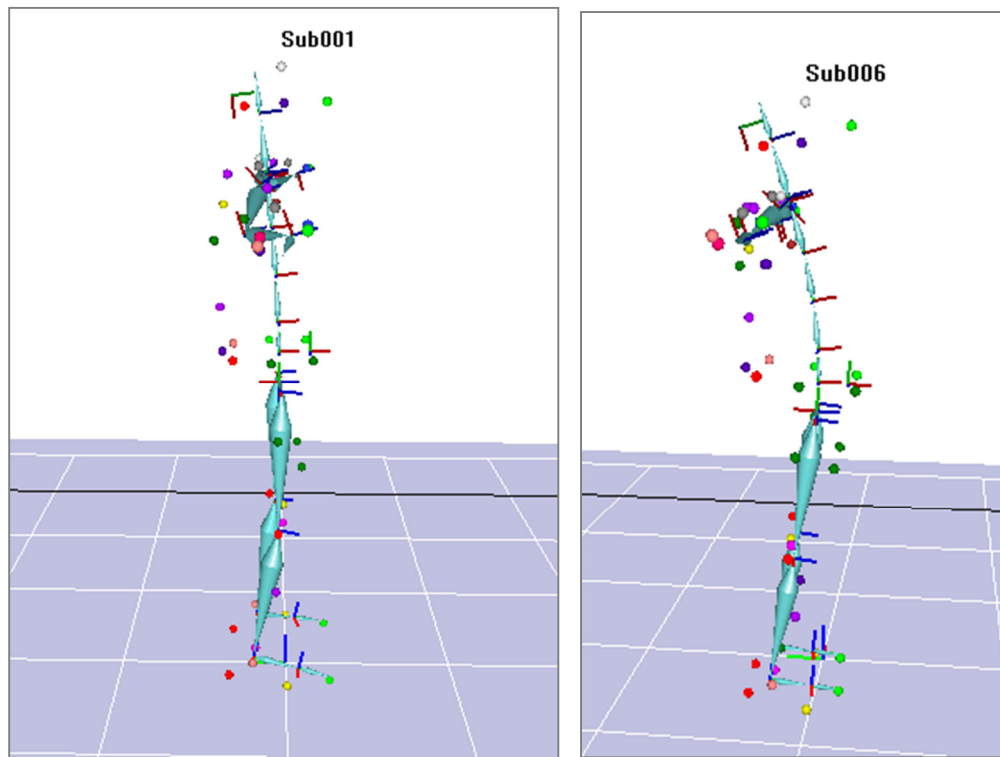

Figure 7.9-1. Participant 001 with an Average Girth and Participant 006 with a Larger Girth

While VEL operators perform the activities detailed in the abovementioned paragraph, human factors engineers review the live motion videos and develop a task breakdown worksheet. This worksheet lists motion capture sessions, corresponding Cortex file names, details the motion descriptions, approximate time stamps for the start/end of each subtasks, and each key posture for a given participant (Table 7.9-1). The task breakdown worksheet contains the PMD search keywords and Jack file names associated with each element. See Appendix E for motion segmentation using the task breakdown worksheet.



	NASA Engineering and Safety Center Technical Assessment Report	Document #: NESC-RP-12-00774	Version: 1.0
		Title: CAD Tools to Support Human Factors Design Teams	

Table 7.9-1. Example Task Breakdown Worksheet with Segment Times and Descriptions

Video time (min:sec)	T-pose / Moccup reference time	VEL time reference column (Cortez)	JACK frame reference	checkpoint type	posture element? (x = yes)	Elements (bold) & checkpoint descriptions	JACK Posture
reference video: 20121214_103423_right-side_USE_wooden-and-plexi-hatch.mp4							
1:54	0:00					T-pose, start of arms dropping	
1:55	0:01			start		arms down, stepping towards hatch	
1:58	0:04			start		Grasping door before lift	
1:59	0:05				x	bent over & lifting door from hatch	P01a
2:00	0:06				x	holding door & turning	P01b
2:03	0:09			stop/start	x	resting door on GSE shelf before standing	P01c
2:04	0:10			start	x	grasping battery LRU on GSE shelf	P01a
2:05	0:11				x	LRU lifted chest height & turning	P01b
2:09	0:15				x	LRU inserted through hatch & lowering, pre-release	P01c
2:11	0:17			stop/start		arms dropped after task, standing straight	
2:13	0:19				x	bent over & lifting LRU from inside hatch	P02a
2:17	0:23			stop	x	LRU released on GSE shelf	P02b
2:18	0:24			start	x	grasping door to lift from GSE shelf	P02a
2:20	0:26				x	holding door & turning	P02b
2:23	0:29				x	place door against hatch	P02c
2:28	0:34			stop		arms dropped	
						arms starting to rise for T-pose	

The live videos are edited to extract videos, one for each subtask, and named according to PMD file name structure. Upon receiving the task breakdown worksheet, VEL operators review each raw channelset, refine the time stamps in the task breakdown worksheet, produce the posture files and screenshot picture files for each key posture, and edit channelsets that represent subtasks and/or elements named according to the PMD file structure. All subtask channelsets are screen recorded to produce videos. Analyses, which include lower back, static strength prediction, and fatigue analysis, are performed for each subtask channelset. A Jack environment that contains the human figure with the matched anthropometric data, stationary objects that represent mockups (if available), and postures are archived. Tests are performed for each environment folder to ensure the working operation of associated channelsets and postures. This is important since an environment file within the Environment folder has file linkages to access the other files within the same folder. All environment, analysis, media, and channelset files are named and reorganized to a strict file structure to be zipped into a packet.

Each compressed file contains a single task and the associated subtasks/elements. Files adhere to a naming structure showing at which level (i.e., task, subtask, and element) the information is provided. Files are organized in four folders according to the type of file (i.e., Channelset, Data, Media, and Environment). All of the examples shown would be found in the compressed folder “sub-001-hatch-01.zip.” The reason for files to be compressed at the task level is three-fold. One reason is only one Jack environment needs to be provided for each of the associated subtask motions and element motions/postures. Another is the environment file depends on folder links for a Jack environment to operate. Therefore, it is important the Environment folder as a whole

	NASA Engineering and Safety Center Technical Assessment Report	Document #: NESC-RP- 12-00774	Version: 1.0
		Title: CAD Tools to Support Human Factors Design Teams	

is downloaded and intact. Lastly, a user may want the motions associated with that task and it is easier to perform one download of the whole task rather than searching for the associated subtasks/elements and performing multiple downloads.

When opening the folder, there will be four folders for each subtask. If the user wants to see images, then the files will be located in the Media folder. If the user wants to see analysis, then the files will be located in the Data folder. If the user wants to create a simulation out of channelset motions, then the environment file is opened from the Environment folder and channelsets can be added from the Channelset folder. Posture files have been incorporated into the environment, so the user does not need to upload posture files into an environment. Upon opening the Jack environment for a given task, the figure has the associated posture attached. Table 7.9-2 shows the User’s Guide detailing how to use the database and the channelsets and postures within Jack software (see Appendix G for additional details).

Table 7.9-2. User’s Guide for Database

General Type of Files	File Naming Convention	Example
Task	sub-(subj #)-(func name)-(task #)	sub-001-hatch-01
Subtask	sub-(subj #)-(func name)-(task #)-(subtask #)	sub-001-hatch-01-01
Element-motion	sub-(subj #)-(func name)-(task #)-(subtask #)-(element #)	sub-001-hatch-01-01-01
Element-posture	sub-(subj #)-(func name)-(task #)-(subtask #){posture letter}	sub-001-hatch-01-01a

Specific Type of Files/Folder	File Naming Convention	Example	Folder Location
Static Strength Prediction of a subtask	sub-(subj #)-(func name)-(task #)-(subtask #)-SSP.xlsx	sub-001-hatch-01-01-SSP.xlsx	sub-001-hatch-01-01 data
Lower Back Analysis of a subtask	sub-(subj #)-(func name)-(task #)-(subtask #)-LBA.xlsx	sub-001-hatch-01-01-LBA.xlsx	sub-001-hatch-01-01 data
Fatigue Analysis of a subtask	sub-(subj #)-(func name)-(task #)-(subtask #)-FA.xlsx	sub-001-hatch-01-01-FA.xlsx	sub-001-hatch-01-01 data
Channelset of a subtask	sub-(subj #)-(func name)-(task #)-(subtask #)-00_chset.env	sub-001-hatch-01-01-00_chset.env	sub-001-hatch-01-01 chsets
Channelset of an element	sub-(subj #)-(func name)-(task #)-(subtask #)-(element #)_chset.env	sub-001-hatch-01-01-01_chset.env	sub-001-hatch-01-01 chsets
Channelset of another element	sub-(subj #)-(func name)-(task #)-(subtask #)-(element #)_chset.env	sub-001-hatch-01-01-02_chset.env	sub-001-hatch-01-01 chsets
Live video of a subtask from Camera 1	sub-(subj #)-(func name)-(task #)-(subtask #)-live1.avi	sub-001-hatch-01-01-live1.avi	sub-001-hatch-01-01 media
Live video of a subtask from Camera 2	sub-(subj #)-(func name)-(task #)-(subtask #)-live2.avi	sub-001-hatch-01-01-live2.avi	sub-001-hatch-01-01 media
Jack video of a subtask	sub-(subj #)-(func name)-(task #)-(subtask #)-jack.avi	sub-001-hatch-01-01-jack.avi	sub-001-hatch-01-01 media
Jack picture of a posture	sub-(subj #)-(func name)-(task #)-(subtask #){posture letter}.png	sub-001-hatch-01-01a.png	sub-001-hatch-01-01 media
Environment File	sub-(subj #)-(func name)-(task #) env.env	sub-001-hatch-01 env.env	sub-001-hatch-01-01 env
Element posture file	sub-(subj #)-(func name)-(task #)-(subtask #){posture letter}.post	sub-001-hatch-01-01a.post	sub-001-hatch-01-01 env/sub001

7.10 Motion Data – Observations, Issues, and Improvements

Participant 001 was used for prototype database generation with a solid surface plywood hatch mockup. This mockup significantly interfered with camera tracking of the markers, especially on the hands. When Participant 001 performed the edge cover installation, the 4 markers in each hand disappeared. The Cortex software can often guess the location of a missing marker based on the locations of nearby markers. However, if several linked markers are missing (e.g., four hand markers), the software cannot approximate the hand bone location. This issue was resolved

	NASA Engineering and Safety Center Technical Assessment Report	Document #: NESC-RP- 12-00774	Version: 1.0
Title: CAD Tools to Support Human Factors Design Teams		Page #: 47 of 142	

by creating a wireframe hatch, which significantly improved the motion capture data. Interference from the wooden hatch was apparent with markers in close proximity to the reflective wooden surface producing ghost markers. This phenomenon could be mitigated with matte painted surfaces.

In Phase 1, recordings were required to be completed within the same session. Suit changes can shift the marker position and alter the bone calculations. Markers are often utilized on different suits due to their limited quantity. It was difficult to replace markers in exactly the same place as before. Part of the procedure and expectation for the participants was they commit to one long session to complete all recordings. Participants could return for additional recording, but they would have to be treated as a new participant in terms of motion capture data.

For Phase 2 this issue was minimized. Through use of the default template created for Phase 2 and “New Subject” tool within the Cortex software, issues surrounding marker shifting and/or swapping participants were rectified. This process helped alleviate the issue surrounding markers being removed from one suit to be placed on another because of the limited number of markers available. Additional markers were purchased for Phase 2 to address this issue. However, the total number of markers available is still less than the number that would be required to outfit each participant suit individually. These improvements allowed Phase 2 to have more freedom in session scheduling and it was left to each participant to decide between a single long session and several shorter sessions.

All recordings started and ended with a T-Pose. This allowed the Cortex software to identify the participant and markers. The software tracked markers based on the continuity of time and space. If the software lost track of too many markers during the recording, then a T-Pose posture at the end of the recording could be used as a starting point and track the markers backwards in time.

During the breakdown of motion capture sessions, it was observed that some participants rushed from one subtask to another. This caused awkward subtask start and end positions. For example, a motion capture session would involve installing protective covers then installing a LRU. Installing protective covers and installing LRU are two separate independent subtasks. A participant would finish installing the protective covers and retrieve the LRU with hands extended. This did not produce a defined stopping/starting point during this transition between subtasks. Briefing the participants was subsequently revised to include the advisement to not rush and include “pauses” between motions.

Lower back, fatigue, and static strength prediction analyses were the only three time-based analyses offered by the Jack software. An add-on software module called the Task Analysis Toolkit (TAT) Reporter allowed analysis outputs to comma-separated values (CSV) Microsoft® Excel spreadsheets with analysis values at each time interval. Jack software offers other analysis types, including: rapid upper limb assessment, NIOSH, Ovako working posture analysis, and manual handling limits. Any of these analyses can be performed by the Jack user on channelset motions, a series of channelset motions, or individual postures. Initially, the results of NOISH

	NASA Engineering and Safety Center Technical Assessment Report	Document #: NESC-RP-12-00774	Version: 1.0
Title: CAD Tools to Support Human Factors Design Teams		Page #: 48 of 142	

analysis was planned to be an output of the database package. However, the methodology of calculating the NIOSH values requires two postures (i.e., from point A to point B) and other data (e.g., object weight). Each user would have different inputs for the NIOSH analysis, so even though the analysis can be part of the data package, it is more effective to defer to the user to perform the analysis. More details on the NIOSH lifting equation can be found in Appendix J.

When chaining element motion channelsets to create a new subtask motion channelset, there was the possibility of gaps between start and stop points that cause the avatar to “jump.” This effect resulted from instantaneously changing posture and/or location. There are techniques for smoothing those transitions that are addressed in the PMD tutorial.

Finally in Phase 1, only the human body motions were captured. There were two other types of entities that could potentially be captured for playback: objects and hands/fingers. Markers can be placed on objects and the Cortex software can simultaneously recognize multiple entities (e.g., humans and objects). A singular “bone” is used in the Cortex software to represent the object and attached to a CAD model in the Jack software. So, when the physical object moved, so did the CAD model in the Jack environment. There has been success in performing a live demonstration of a tracked human manipulating a tracked object in a Jack environment. However, recording the motions of a human and an object simultaneously as a Jack channelset has yet to be assessed in the VEL.

Phase 2 began the process of integrating object tracking with the human tracking being performed. While not all objects were tracked, several were in an attempt to generate a better data set for the software user. Examples of objects tracked in Phase 2 include a wireframe LRU, a wooden battery LRU, and a plywood hatch door. Phase 2 did not incorporate hand tracking into the final data set because of time limitations.

7.11 Motion Data – Fingers and Hands

The other entities yet to be tracked are fingers. In this study, the fingers were fixed on the avatars. Previous VEL experience has shown using markers on each finger segment demonstrated poor results because of too many markers in close proximity. An increased number of cameras or upgraded cameras with a higher resolution might allow this type of hand tracking. Cybergloves were obtained prior to study initiation and used to track the movement of each finger segment by flexion and abduction sensors. Cybergloves were not initially used for this study because the primary focus was on the human body motions. However, being able to grip and reach is a desired motion to capture by some human factor engineers. Motion capture in conjunction with a singular cyberglove was successfully implemented for a live demonstration in the Jack software. There were several obstacles to being able to record both cybergloves simultaneously with human body motion capture. First, data from the cybergloves were transmitted via Bluetooth. Transmitting two data streams at the same time wirelessly can be problematic. The second obstacle was the current VEL procedure did not easily allow for cyberglove data recording. Data from cyberglove streams directly to the Jack software, which is

	NASA Engineering and Safety Center Technical Assessment Report	Document #: NESC-RP-12-00774	Version: 1.0
Title: CAD Tools to Support Human Factors Design Teams		Page #: 49 of 142	

independent from the Cortex software data stream. The schematic shown in Figure 7.11-1 depicts the two different data streams into Jack software.

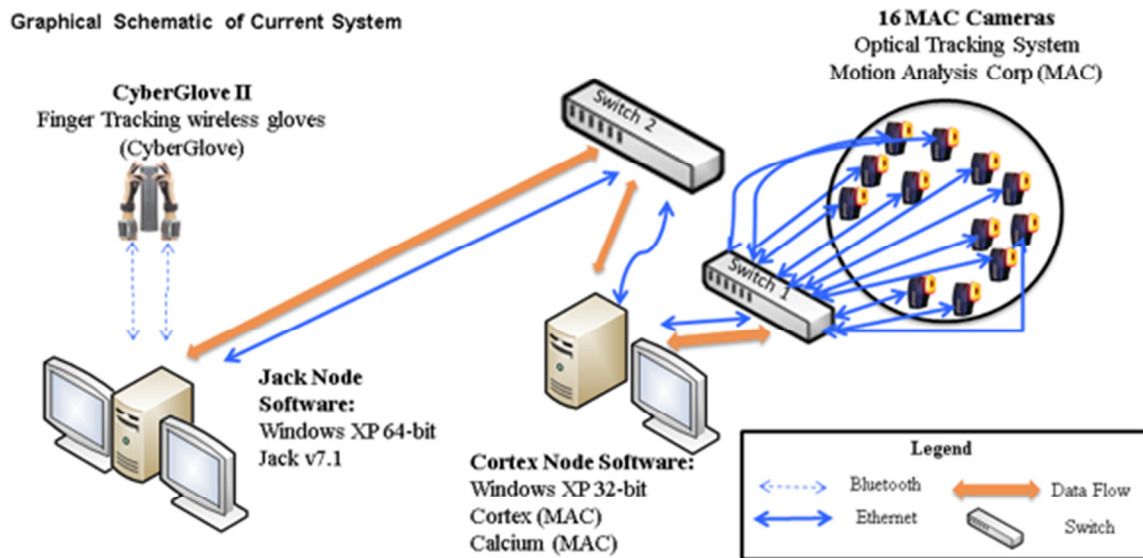



Figure 7.11-1. Simple VEL Schematic

There were two possible solutions to these issues. The first solution is to record a participant doing a T-Pose and several ROM captures to create a template and calculate the participant bones, or use the default template created from a detailed ROM capture and use the “New Subject” tool within the Cortex software to apply the template to the participant in question. While doing a PMD task, Cortex software and cybergloves would have to be fed live data stream to the Jack software, which is the procedure for live tracking motions. With the two live data streams, the software can record data streams simultaneously as a channelset. The challenge with this solution is the motion data is likely to be inaccurate without the post-process data clean up. With improvements in template creation and by filling marker gaps virtually, this process may become feasible. Given the time to research this, it may be possible to record channelsets directly from the software and skip the post-process clean up in certain cases if various improvements can be made.

The second solution is while performing a PMD task, record the human body motions through the Cortex software and record the cyberglove motions through the Jack software as a channelset. After cleaning up the human body motion data, the Jack software records the motions of the cleaned up data as a channelset. There may be a way to simultaneously combine two channelsets as one motion. It is uncertain if this solution is feasible. An assessment must be made to determine if incorporating cyberglove data is feasible and whether it is beneficial enough to justify the additional effort.

	NASA Engineering and Safety Center Technical Assessment Report	Document #: NESC-RP- 12-00774	Version: 1.0
Title: CAD Tools to Support Human Factors Design Teams		Page #: 50 of 142	

7.12 Motion Data – Aligning Positions

All motion data (channelsets) have an associated coordinate system that allows the environment to be manipulated to change the scenery around the motion. However, if two motions were linked and occurred in different areas based on the same coordinate system, there would be a jump in terms of positions. For example, if there are two copies of a channelset motion of a person walking from point A to B and they are played back-to-back, the entire motion would show a person walking from point A to B, instantaneously jump back to A and walk from point A to B. Some users may want to be able to retrofit the start point of a motion to the end point of the previous motion. It is unlikely to be able to reset the coordinate system in the middle of the motion so that the person would be able to walk from point A to B to C. This limitation must be kept in mind when creating a string of channelsets.

7.13 Task Performance

In general, participants had minimal trouble completing the prescribed subtasks and some were surprised the capture sessions did not last longer or involve more complex ground processing tasks. However, the shorter female participants experienced difficulty with completing subtasks that required far reaches up and inside the hatch, reaching certain connectors in the connector mockup, and with reaching over to transfer the battery LRU past the simulated gap at the platform edge and through the hatch onto an internal shelf. Taller male participants were forced to duck their heads during hatch ingress/egress and bend over farther for lifting/lowering tasks. These are desirable behavioral results and participant impressions for several reasons: 1) clean quality data were captured with minimal failures or fatigue; 2) extensive task rehearsal was not necessary; 3) participants rarely turned their heads or took long, unnatural pauses to ask questions; and 4) participants left with a positive impression of the experience. Figure 7.13-1 shows the participant postures for each subtask. The subtask sequences used during motion capture sessions are detailed in Appendix C.



NASA Engineering and Safety Center Technical Assessment Report

Document #:
**NESC-RP-
12-00774**

Version:
1.0

Title:

CAD Tools to Support Human Factors Design Teams

Page #:
51 of 142

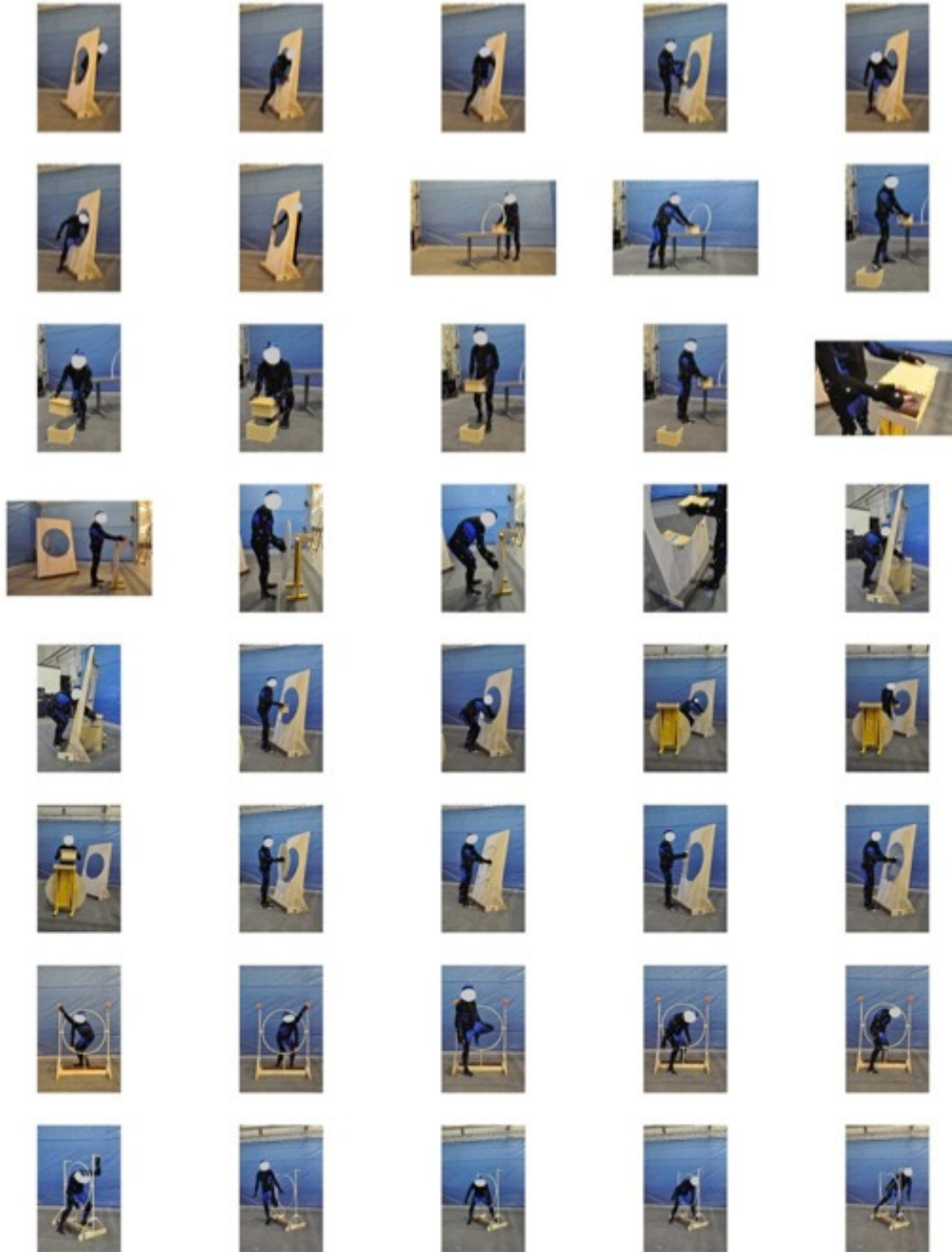



Figure 7.13-1. Participant Postures while Performing Subtasks in Phase 1

	NASA Engineering and Safety Center Technical Assessment Report	Document #: NESC-RP- 12-00774	Version: 1.0
Title: CAD Tools to Support Human Factors Design Teams		Page #: 52 of 142	

7.14 Human Factors Analysis

Three types of analysis data were provided in CSV format as part of each compressed file: static strength prediction, fatigue analysis, and lower back analysis. These analyses were conducted in Jack software on channelsets at the subtask level. Figure 7.14-1 shows three different postures extracted from a Jack subtask animation and the corresponding frames from live video.

Figures 7.14-2 and 7.14-3 show the possible analysis results from the raw data provided, or from custom outputs from the Jack software using channelsets and the Analysis window or the TAT Reporter module. Please refer to the “VEL Instructions”² or the Jack software manual for how to utilize the analysis capabilities.

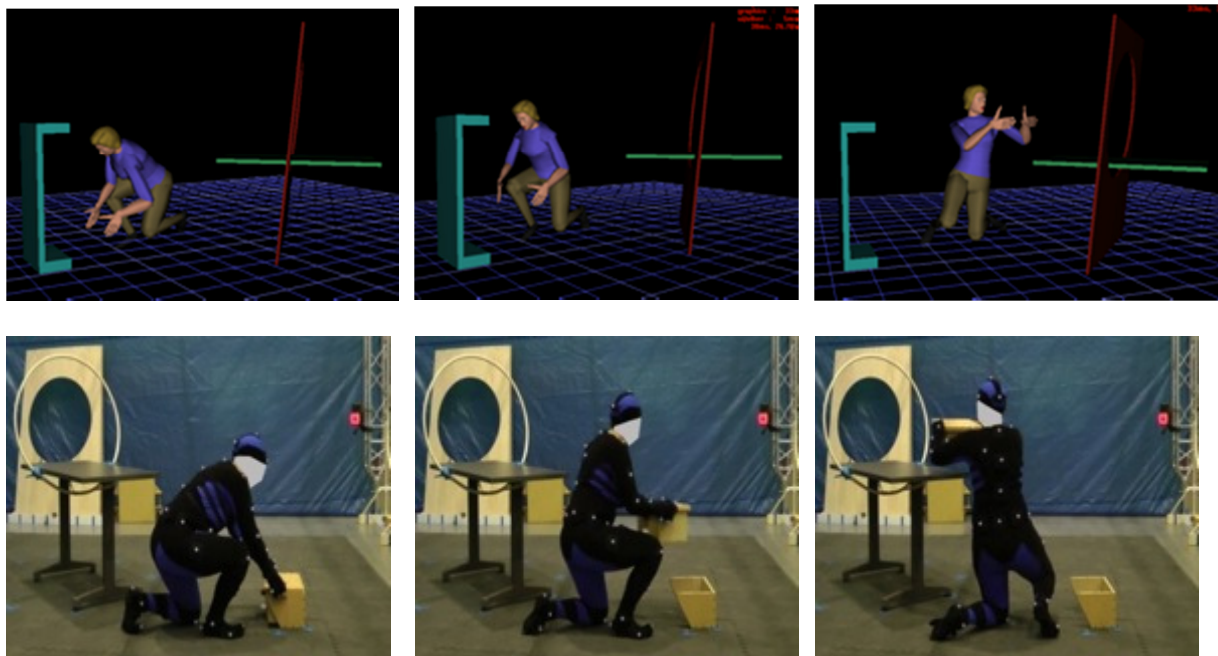

Figure 7.14-1. Three Postures during LRU Transfer Subtask, Live Video, and Jack Software Animation

² VEL-Motion-Capture_Instructions.docx



Title:

CAD Tools to Support Human Factors Design Teams

Page #:
53 of 142

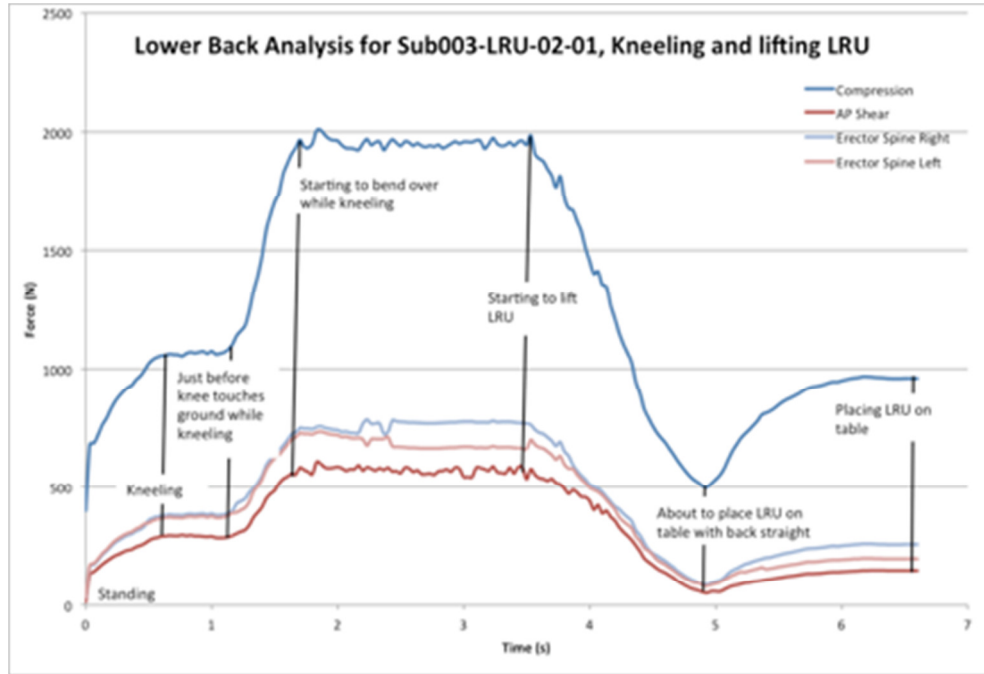

Figure 7.14-2. Example Output from Jack Software for Low Back Analysis

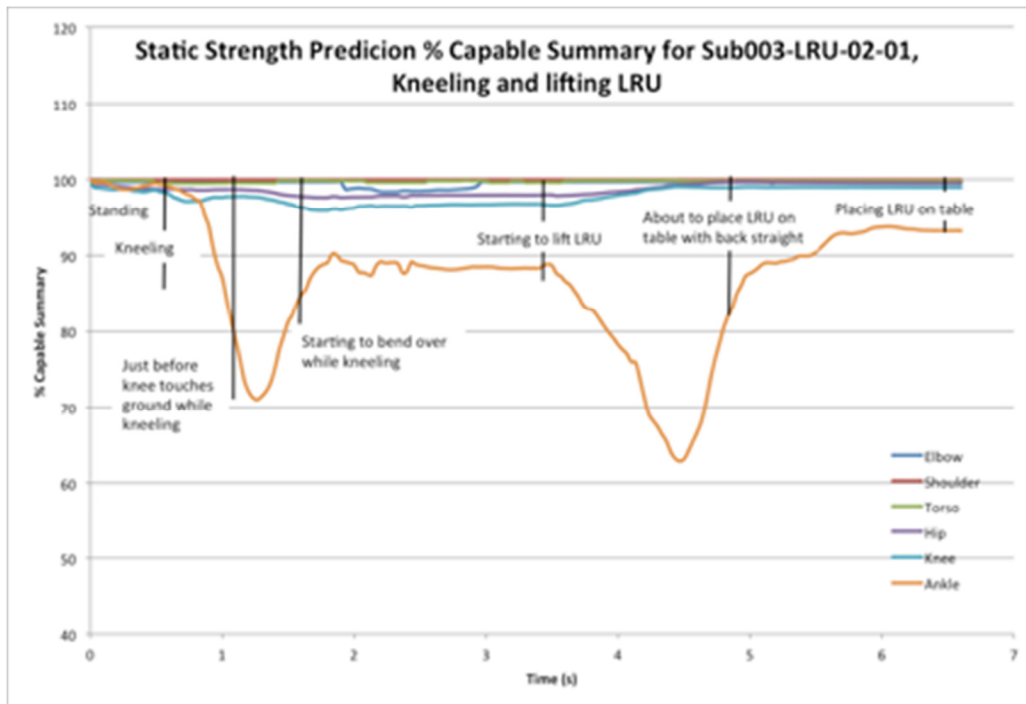



Figure 7.14-3. Example Output from Jack Software for Static Strength Prediction

	NASA Engineering and Safety Center Technical Assessment Report	Document #: NESC-RP- 12-00774	Version: 1.0
Title: CAD Tools to Support Human Factors Design Teams		Page #: 54 of 142	

7.15 NIOSH Lifting Limits

In 1981, in response to OSHA law, NIOSH created a lifting limit equation to reduce poor lifting practices injuries. Research indicated a third of compensated industrial injuries were back injuries. Industry is required to apply the equation per the OSHA General Duty Clause, which demands an environment “free from recognized hazards that are causing or are likely to cause serious physical harm.” A revised equation must be applied to where lifting applications may cause employee harm and serves as an ergonomically measurable analysis tool. The equation addresses two aspects of lifting and carrying. They are the action limit (AL) and the maximum permissible limit (MPL), with the latter being achieved only by trained personnel. The equation is explained in detail in Appendix J. It is a function of the Jack software and will predict upper limits in mass handling in a virtual ground processing environment. It also was addressed for the human subjects performing the test activities necessary to obtain the library element data.

7.16 Database Implementation

The database was designed to support human factors stakeholders throughout the NASA community by developing a dynamic webpage with the PMD stored in a MySQL database linked to the webpage (see Figure 7.16-1). Because of limited schedule and budget for the pilot phase, the PMD resides on an internal server. To facilitate the development, MAMP was loaded on a Macintosh workstation. MAMP is an open source package that provides a local PHP development environment. When development is complete, the database and webpage scripts were moved to the MSFC server for implementation. The MAMP system provides PHP and MySQL administrative tools, which provide the ability to create the database and its tables, to define indexes in tables, and links between tables. They provide a means to load and retrieve data and perform queries. PHP scripts that address the database can be developed and tested locally and over the MSFC network.

	NASA Engineering and Safety Center Technical Assessment Report	Document #: NESC-RP-12-00774	Version: 1.0
Title: CAD Tools to Support Human Factors Design Teams		Page #: 55 of 142	

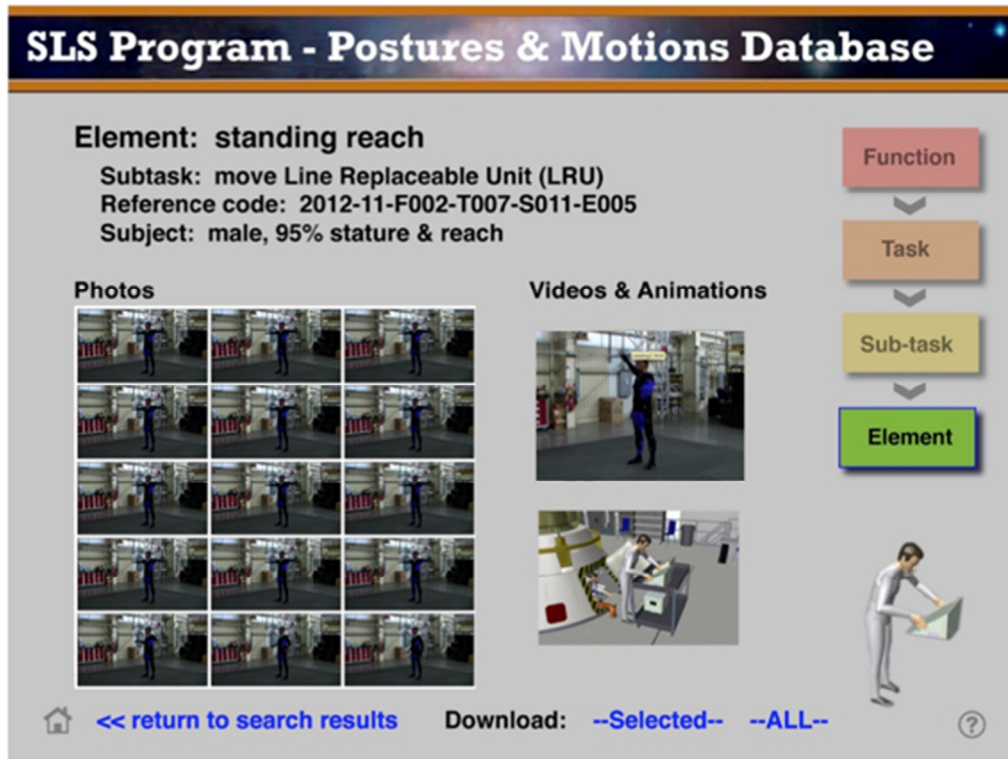



Figure 7.16-1. Pilot Phase PMD Topology

7.17 Website Interface

The database team established search and download techniques that would make the various types of data easily understood and retrievable by the user. Emphasis was placed on supporting the users with an intuitive, functional database. Figure 7.17-1 shows web interface for the pilot database. Searches are made using element, subtask and task keywords, and human operator (participant) characteristics. Results are displayed as a list of elements, with thumbnail images, operational relationships (i.e., corresponding Function and Task), and a link to downloadable task-level data packet. Methods for hosting and accessing data were researched. See Appendix G for additional technical details on database structure.

	NASA Engineering and Safety Center Technical Assessment Report	Document #: NESC-RP-12-00774	Version: 1.0
Title: CAD Tools to Support Human Factors Design Teams		Page #: 56 of 142	

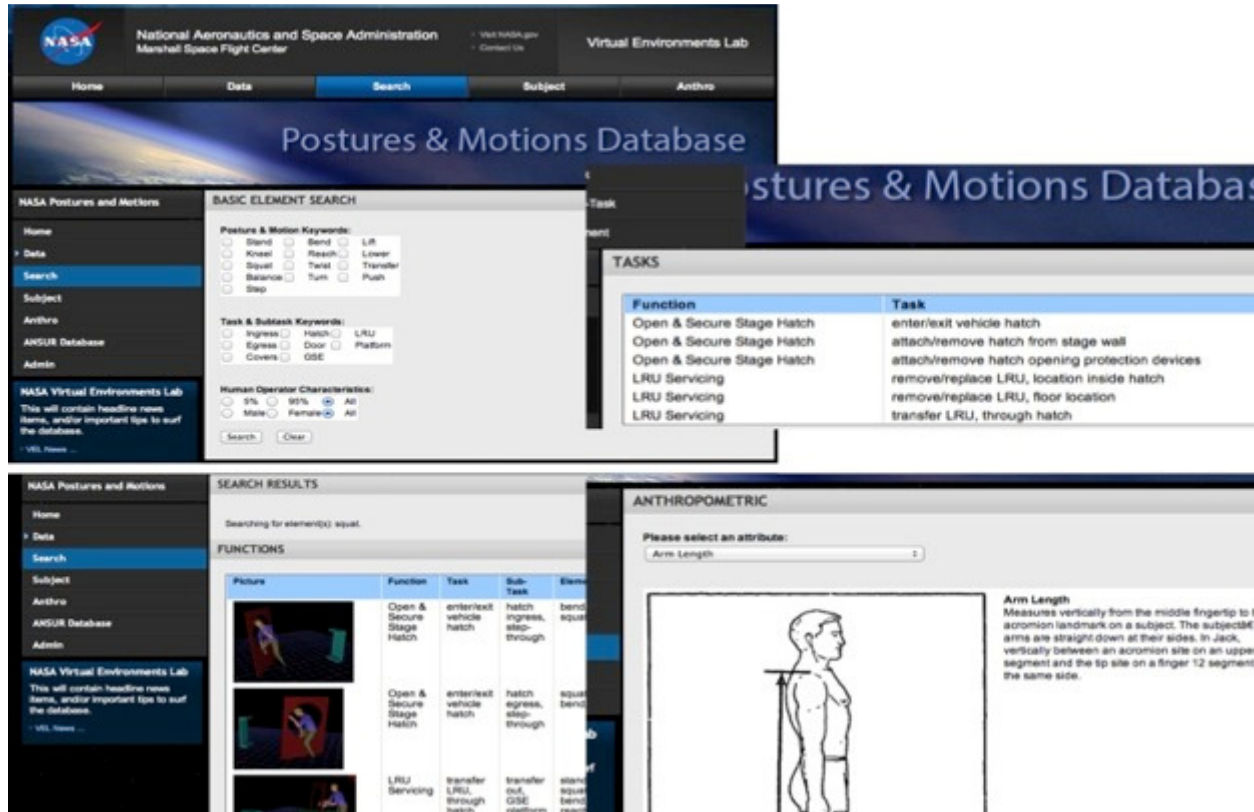

Figure 7.17-1. Example Webpages for PMD Search, Display, and Results Pages

8.0 Findings, Observations, and NESC Recommendations

Findings in this study address salient points that should be considered in future efforts for additional study pursuit.

8.1 Findings

The following findings were identified:

- F-1.** Based upon the prototypical study results, a motion capture database is feasible and can be used in the aerospace industry with appropriately trained operators, analysts, and available software.
- F-2.** With the Jack software, users are able to link motion elements (segments) to create subtasks within CAD environments containing workspaces and objects.
- F-3.** The defined motion capture elements created in the database can be feasibly linked to produce other performance simulations of varying length.

	NASA Engineering and Safety Center Technical Assessment Report	Document #: NESC-RP-12-00774	Version: 1.0
Title: CAD Tools to Support Human Factors Design Teams		Page #: 57 of 142	

- F-4.** The NIOSH lifting equation cannot be accurately calculated by using only the Jack software as it only measures at two points (start and end) and does not include the various body measurements one might experience between the two points.
- F-5.** The Jack software was constrained to simple motions and postures which, when chained into subtask operations, periodically had missing data (gaps) depicted as no avatar figure in a chain of motions or the avatar instantaneously relocating or changing posture.
- F-6.** Use of cybergloves and/or finger markers would allow analysts to capture and analyze the dexterity of a participant while performing tasks and would increase the fidelity of motions stored in the PMD. Use of participant head-mounted display would impact mockup fidelity, with augmented reality only requiring physical “touch points” versus entire visible mockup.
- F-7.** The pilot study simulations displayed fixed hand positions when interfacing with virtual equipment where details of hand gripping, pinching, and reach positions were not available.
- F-8.** The pilot study used software and a database system on a limited access server within the MSFC firewall. Existing software/database access protocol must be addressed at MSFC and Agency levels to enable database access.

8.2 Observations

The following observations were identified in the study:

- O-1.** The number of test participants used was minimally sufficient to gather prototypical pilot data and prove the concept.
- O-2.** To drive the motion capture, typical representative subtasks were utilized from as many postures and motions from the identified list (see Section 7.0) as feasible and could be applicable to any spaceflight vehicle.
- O-3.** With sufficient camera coverage, small, with respect to the participant, solid mockups might be used for motion capture.
- O-4.** As the 5th and 95th percentile persons only exist as an ideal for assessing body measurements, stature and reach were appropriate measures to emphasize when recruiting from the available test participant pool.
- O-5.** In Phase 1, only the human body motions were captured.

	NASA Engineering and Safety Center Technical Assessment Report	Document #: NESC-RP-12-00774	Version: 1.0
Title: CAD Tools to Support Human Factors Design Teams		Page #: 58 of 142	

8.3 NESC Recommendations

The following recommendations were identified and directed towards the Office of Primary Responsibility for the NASA SFHSS, NASA-STD-3001 Volume 2, and the Human Integration Design Handbook (HIDH).

- R-1.** Expand the PMD to meet the needs of projects and programs like GSDO and SLS in their launch vehicle ground processing and maintenance design trades and analyses. *(F-1 through F-8, O-1, O-2, O-3, and O-5)*
- R-2.** For the purposes of verification, expand the definition of modeling to include digital human models simulating a range of anthropometric measures, such as 95th percentile or more male and 5th percentile or less female. *(O-4)*

9.0 Alternate Viewpoint

There were no alternate viewpoints identified during the course of this assessment by the NESC team or the NRB quorum.

10.0 Deliverables

PMD

The study deliverables include a prototype PMD library of posture and motion elements representative of what might be provided in detail with additional resources. The pilot study database library had adequate connectivity within its components and with representative data input to allow the concept to be demonstrated and verified. However, a more comprehensive version will be required to meet the needs of pre-launch spaceflight vehicle processing design and operations.

User's Manual

A user's manual accompanies the database so that subsequent users can understand the protocol and logic for the program and how the data may be utilized in digital human modeling software for design and analysis.

11.0 Lessons Learned

- LL-1.** There is great potential in using motion capture technology to capture real human postures and motions for incorporation into digital human modeling environments, but there are limitations. Engineering needs this knowledge and it can be captured in useful ways; however, there is still significant work to be done to validate the models as appropriate for requirements verification.

	NASA Engineering and Safety Center Technical Assessment Report	Document #: NESC-RP- 12-00774	Version: 1.0
		Title: CAD Tools to Support Human Factors Design Teams	

12.0 Recommendations for NASA Standards and Specifications

The recommendations for NASA standards and specifications include the following:

- Add to NASA SFHSS NASA-STD-3001 a recommendation on how to successfully engineer for ground support operations and maintenance by using the techniques used to create this database and the postures and motions contained in the database.
- Modify NASA SFHSS NASA-STD-3001 to allow requirements validation with digital human models that exhibit anthropometric measures that are within a range meeting the intent for corresponding applicable 5th or 95th percentile body dimensions.
- Add a section to the HIDH explaining the cost-benefit analysis of using digital human modeling in 3-D CAD environments to simulate human interactions in 1-G worksite design, with the caveat being the known limitations (such as the inability to capture hand dexterity and lifting mass) of virtual simulation.

13.0 Definition of Terms

Channelset	3-D human motion file (.env format) of specific time duration, recorded in Jack software and applied to avatars for motion simulation.
Corrective Actions	Changes to design processes, work instructions, workmanship practices, training, inspections, tests, procedures, specifications, drawings, tools, equipment, facilities, resources, or material that result in preventing, minimizing, or limiting the potential for recurrence of a problem.
Finding	A relevant factual conclusion and/or issue that is within the assessment scope and that the team has rigorously based on data from their independent analyses, tests, inspections, and/or reviews of technical documentation.
Lessons Learned	Knowledge, understanding, or conclusive insight gained by experience that may benefit other current or future NASA programs and projects. The experience may be positive, as in a successful test or mission, or negative, as in a mishap or failure.
NIOSH Lifting Equation	A method for quantitatively assessing the physical stress of two-handed manual lifting tasks.
Observation	A noteworthy fact, issue, and/or risk, which may not be directly within the assessment scope, but could generate a separate issue or concern if not addressed. Alternatively, an observation can be a positive acknowledgement of a Center/Program/Project/Organization's operational structure, tools, and/or support provided.

	NASA Engineering and Safety Center Technical Assessment Report	Document #: NESC-RP- 12-00774	Version: 1.0
		Title: CAD Tools to Support Human Factors Design Teams	

Problem	The statement of a subject meriting research with an independent technical assessment.
Proximate Cause	The event(s) that occurred, including any condition(s) that existed immediately before the undesired outcome, directly resulted in its occurrence and, if eliminated or modified, would have prevented the undesired outcome.
Recommendation	A proposed measurable stakeholder action directly supported by specific Finding(s) and/or Observation(s) that will correct or mitigate an identified issue or risk.
Root Cause	One of multiple factors (events, conditions, or organizational factors) that contributed to or created the proximate cause and subsequent undesired outcome and, if eliminated or modified, would have prevented the undesired outcome. Typically, multiple root causes contribute to an undesired outcome.
Supporting Narrative	A paragraph, or section, in an NESC final report that provides the detailed explanation of a succinctly worded finding or observation. For example, the logical deduction that led to a finding or observation; descriptions of assumptions, exceptions, clarifications, and boundary conditions. Avoid squeezing this information into a finding or observation.

14.0 Acronyms List

3-D	Three-dimensional
AL	Action Limit
ANSUR	Army Anthropometric Survey
ARC	Ames Research Center
CAD	Computer-Aided Design
CSV	Comma-separated Values
DHM	Digital Human Modeling
EPA	Environmental Protection Agency
G	Gravity
GSDO	Ground Systems Development and Operations
GSE	Ground Support Equipment
GUI	Graphical User Interface
HEMAP	Human Engineering Modeling and Performance
HFE	Human Factors Engineering
HIDH	Human-Integration Design Handbook
IH	Institutional Health
IRB	Institutional Review Board
IT	Information Technology

	NASA Engineering and Safety Center Technical Assessment Report	Document #: NESC-RP- 12-00774	Version: 1.0
		Title: CAD Tools to Support Human Factors Design Teams	

JSC	Johnson Space Center
KSC	Kennedy Space Center
L/C	Likelihood/Consequences
LR	Level of Risk
LRU	Line Replaceable Unit
MAMP	Macintosh -Apache - MySQL – PHP {development package}
MPCV	Multi-Purpose Crew Vehicle
MPL	Maximum Permissible Limit
MSFC	Marshall Space Flight Center
NESC	NASA Engineering and Safety Center
NIOSH	National Institute for Occupational Safety and Health
NRB	NESC Review Board
NSC	NASA Safety Center
OSHA	Occupational Safety and Health Agency
PMD	Postures and Motions Database
PVC	Polyvinyl Chloride
ROM	Range of Motion
SCAPE	Self Contained Atmospheric Pressurized Ensemble
SFHSS	Space Flight Human System Standard
SIMM	Software for Interactive Musculoskeletal Modeling
SLS	Space Launch System
SME	Subject Matter Expert
SRB	Solid Rocket Booster
TAT	Task Analysis Toolkit
TBD	To Be Determined
VAB	Vertical Assembly Building
VEL	Virtual Environments Laboratory
VPN	Virtual Private Network

15.0 References

1. NRD Request # TI-12-0774; Computer-Aided Design (CAD) Tools to Support Human Factors Design Teams: Primitive Models Database.
2. 1-G Human Factors for Optimal Processing and Operability of Constellation Ground Systems; Section 5; Stambolian, Damon B.; NASA KSC.
3. NASA MSFC Human Research Category II Protocol; Computer-Aided Design Tools to Support Human Factors Design Teams: Primitive Models Database; September 25, 2012.
4. Postures & Motions Library, 11-16-2012 Project Status, Jacobs ESSSA Group, ESSSA-FY13-232_Motions-Database-DRAFT-b.pptx.

	NASA Engineering and Safety Center Technical Assessment Report	Document #: NESC-RP- 12-00774	Version: 1.0
Title: CAD Tools to Support Human Factors Design Teams		Page #: 62 of 142	

5. C3D.org Cramp, Edmund. The 3D Biomechanics Data Standard. 16 January 2013. 23 January 2013 <<http://www.c3d.org/>>.
6. NIOSH Equation; claymore.engineer.gvsu.edu/~buters/egr470/analysistool.html; Grand Valley State University.
7. Human Factors/Worksite Analysis Tools for Immersive/Motion Capture Labs, December 2011, NASA KSC, MSFC BPA NNM09AA00Z, Task NNM11AA76T-HEMAP.
8. 1988 Anthropometric Survey of U.S. Army Personnel: Methods and Summary Statistics. Gordon, Claire C.; Churchill, Thomas; Clauser, Charles E., Bradtmiller, Bruce; McConville, John T., Tebbetts, Ilse; and Walker, Robert A., September, 1989, U.S. Army Natick Research, Development and Engineering Center.

16.0 Appendices

- Appendix A. Operational Definitions
- Appendix B. Mockup Configurations and Subtask Examples
- Appendix C. Research Session Tools and Forms
- Appendix D. Motion Capture – User Guide and Lab Processes
- Appendix E. Data Organization and Naming
- Appendix F. NASA Program Risk Scorecard and Ratings Table
- Appendix G. Database Design Structure and Software
- Appendix H. Database Website Interface – July 31, 2013 version
- Appendix I. Human Research Protocol and Consent Form
- Appendix J. National Institute for Occupational Safety and Health (NIOSH) Lifting Equation (OSHA)
- Appendix K. Phase 2 Quick Look Test Reports



Title:

CAD Tools to Support Human Factors Design Teams

Page #:
63 of 142

Appendix A. Operational Definitions

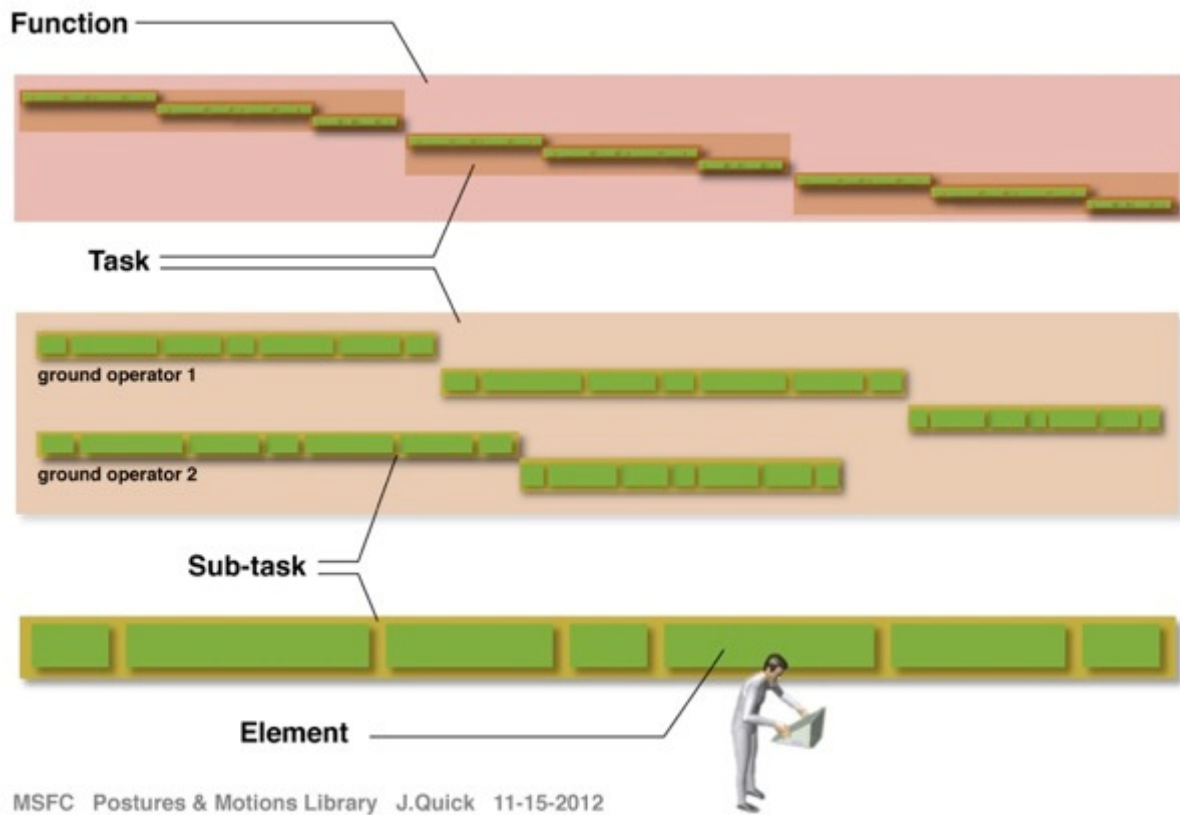

A-1. Operational Definitions - Timeline View



NASA Engineering and Safety Center Technical Assessment Report

Document #:
**NESC-RP-
12-00774**

Version:
1.0

Title:

CAD Tools to Support Human Factors Design Teams

Page #:
64 of 142

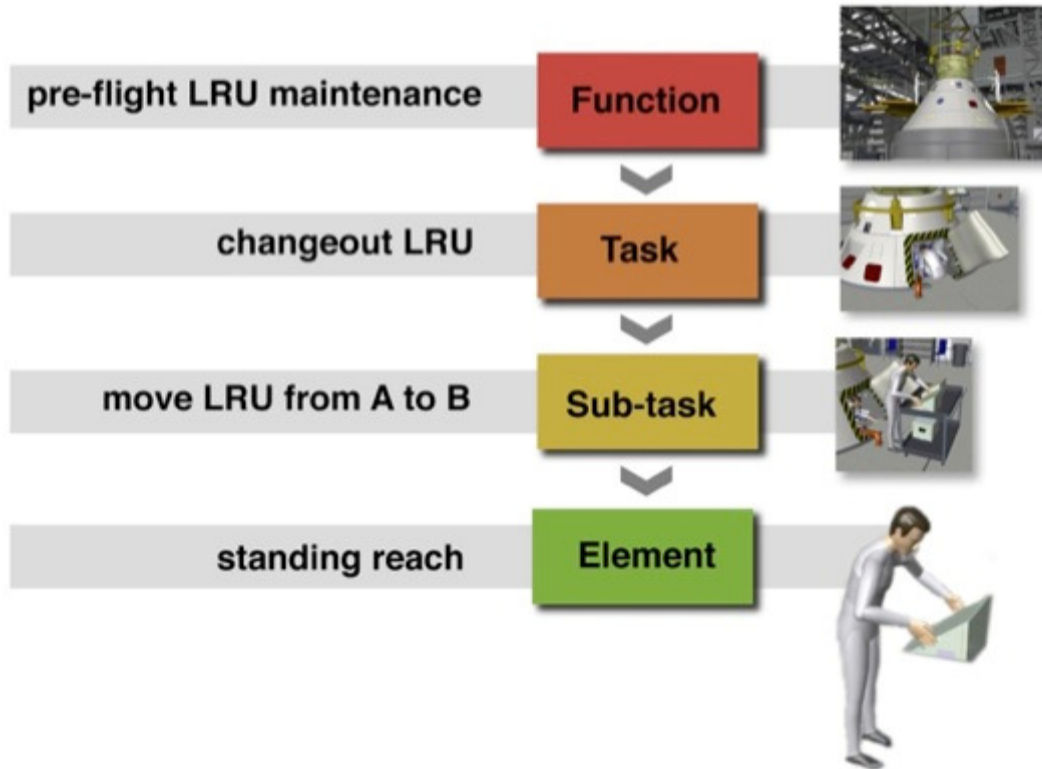

A-2. Operational Definitions – Function-to-Element Flow-down



Title:

CAD Tools to Support Human Factors Design Teams

Page #:
65 of 142

Appendix B. Mockup Configurations and Subtask Examples

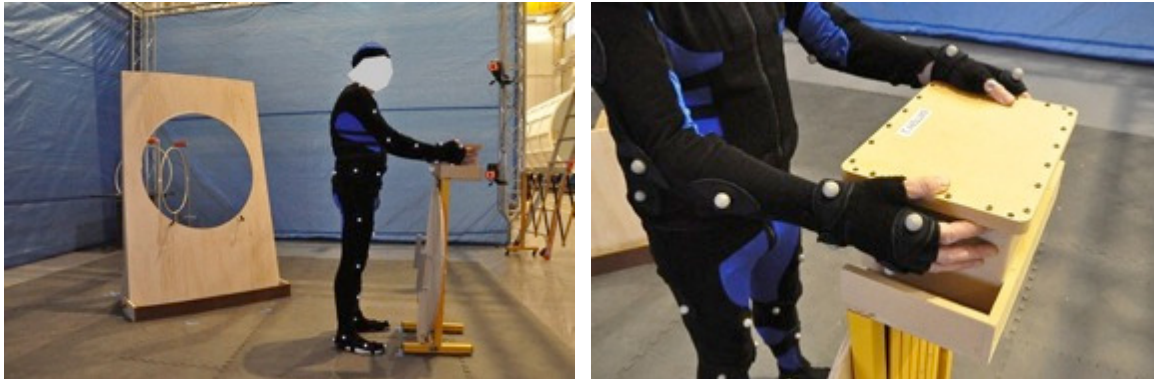

B-1. Solid Surface Hatch Mockup, GSE Shelf with Door and Battery LRU

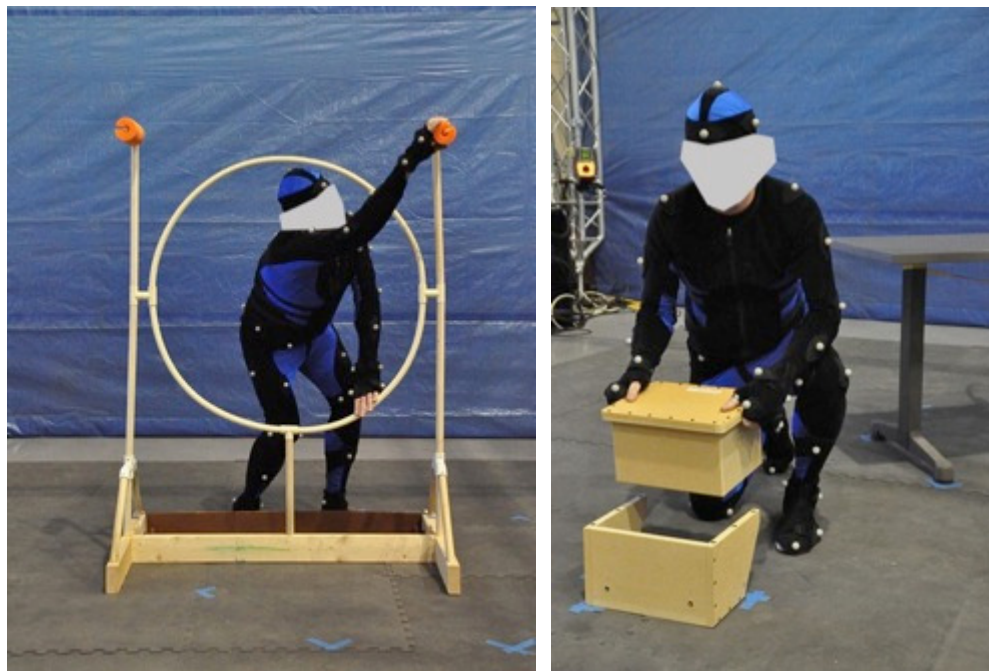

B-2. PVC "Wireframe" Hatch Mockup with Simulated Protrusions/Covers, Battery LRU on Floor



NASA Engineering and Safety Center Technical Assessment Report

Document #:
**NESC-RP-
12-00774**

Version:
1.0

Title:

CAD Tools to Support Human Factors Design Teams

Page #:
66 of 142



B-3. Phase 1 Mockup Details: GSE Shelf, Adjustable toe-kick, Handles on Clear Door



B-4. Phase 2 Mockup Details: Toe-kick/Simulated Platform Edge with Steel Rod and Connectors



**NASA Engineering and Safety Center
Technical Assessment Report**

Document #:
**NESC-RP-
12-00774**

Version:
1.0

Title:

CAD Tools to Support Human Factors Design Teams

Page #:
67 of 142

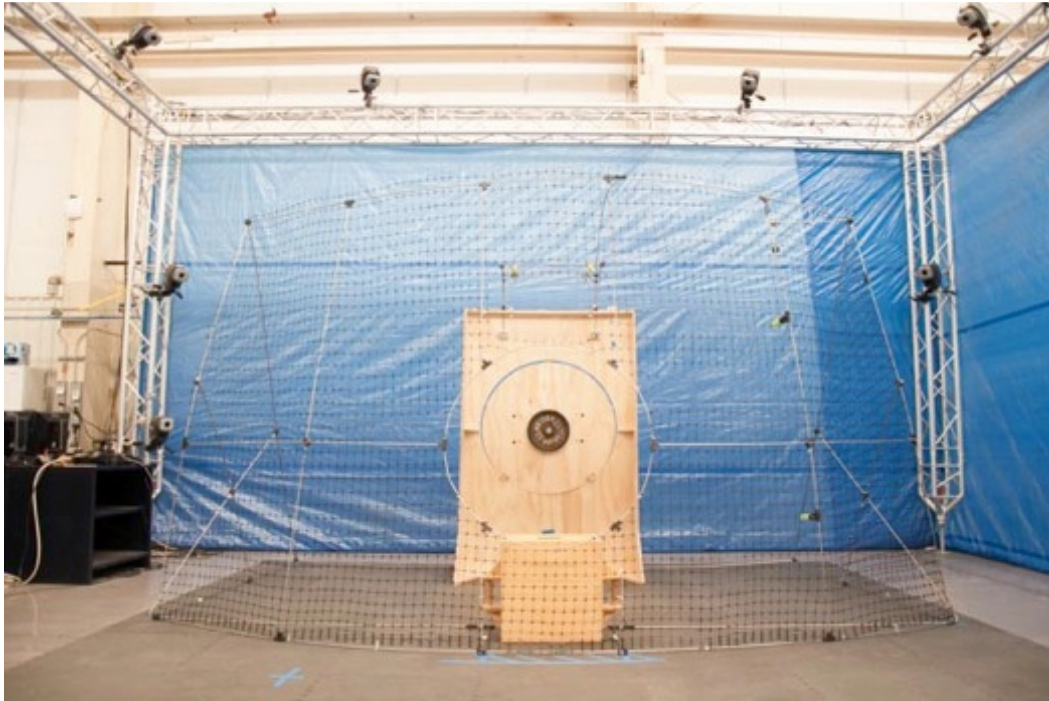

B-5. Phase 2 Mockup of Launch Vehicle Stage Adapter Wall Section with Hatch Opening, Connectors Requiring Tool Manipulation (right side) and Simulated LRU Equipment Shelf Attached to Plywood Structure



B-6. Phase 2 Mockup Details: Door on GSE Shelf, Overhead LRU, and Overhead Connection

	NASA Engineering and Safety Center Technical Assessment Report	Document #: NESC-RP-12-00774	Version: 1.0
Title: CAD Tools to Support Human Factors Design Teams		Page #: 68 of 142	

Appendix C. Research Session Tools and Forms

NESC Participant Sessions - VEL Document Checklist

The following scripts, forms, and data collection tools should be printed and/or available for viewing prior to each task simulation and motion capture session.

1. *Research Activity Description*: Provides overview to acquaint session leader with the process and provide a reference script for talking with participants.

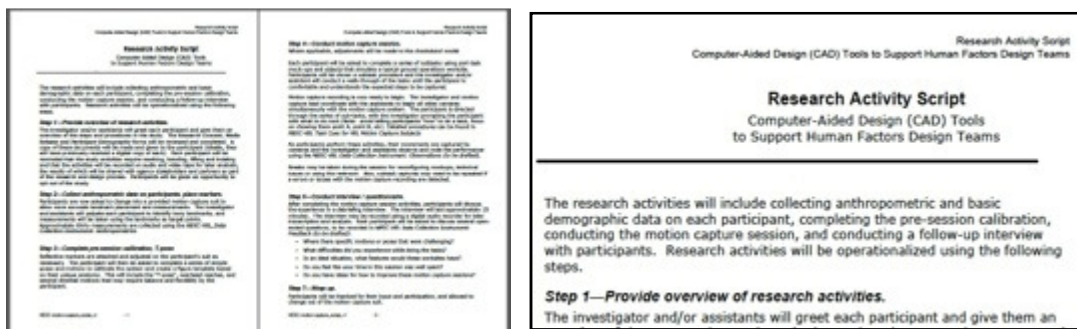

2. *Participant Consent Forms (before session begins)*: Be sure they sign all three pages and include their address and media release signatures on third page. Adding post-it flags beforehand makes this easier.

Summarize the form for participants, have them sign two copies--one is for them to keep, the other is delivered to the NASA project lead.

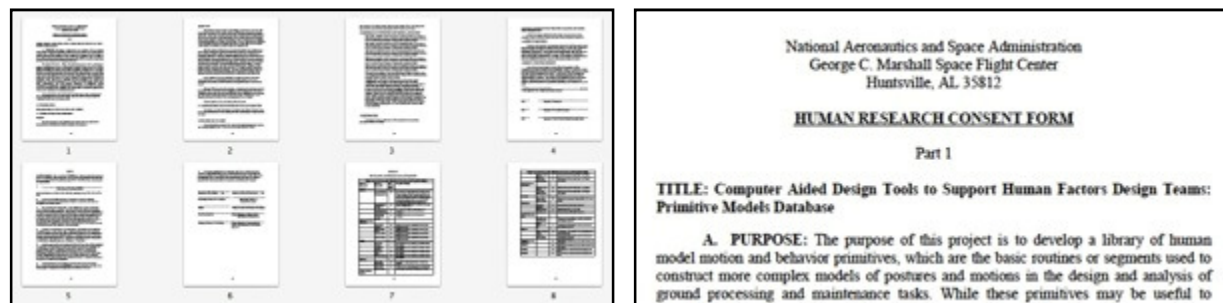

3. *Data Collection: Demographics and Work Experience (before session begins)*: Captures level of ground operations knowledge and discusses physical limitations again. This form and consent forms can be completed before participants change into motion capture suits during orientation.



NASA Engineering and Safety Center Technical Assessment Report

Document #:
**NESC-RP-
12-00774**

Version:
1.0

Title:

CAD Tools to Support Human Factors Design Teams

Page #:
69 of 142

Demographic / Experience / Ability Data - Virtual Environments Lab (VEL), MSFC

Collected by:	MSFC-VEL-Subject #:
Collection date:	Stature % (5, 50 or 95):
Collection notes:	Gender (M or F):
	Other subject info:

Subject's age: _____

Years experience working in Ground Ops-related field: _____

Level of knowledge of pre-launch Ground Operations (1-5, 5 being highest): _____

Level of knowledge of Line Replaceable Unit or LRU shapes, masses & functions (1-5, 5 being highest): _____

Any physical limitations that would limit your ability to complete basic lifting tasks? (max 250 characters for all text boxes below)

NOTE: This is also a good time to introduce participants to the task simulations with a walk-through of the VEL mockups and capture environment.

4. Anthropometrics (before session begins): This data can be captured in a separate session prior to the task simulation session. It is best to measure participants in motion capture suits or athletic clothing they may have brought to wear underneath the suit. Be sure to have the anthropometric reference document on hand, with helpful visual instructions for how to measure. A clipboard is also helpful.

NASA Anthropometry Data Collection - VEL, Rankin & Addicks, Dec 2012

Anthropometric Reference

Height Measurement: The vertical distance between the highest point of the head and the lowest point of the feet. The subject should stand on a flat surface with their feet together and arms at their sides. The measurement should be taken to the top of the head, not the crown of the head.

Torso Length Measurement: The vertical distance between the highest point of the shoulders and the lowest point of the hips. The subject should stand with their feet together and arms at their sides. The measurement should be taken to the highest point of the shoulders, not the acromion process.

Arm Length Measurement: The vertical distance between the highest point of the shoulder and the lowest point of the hand. The subject should stand with their feet together and arms extended straight out to the side. The measurement should be taken to the highest point of the shoulder, not the acromion process.

Head Length Measurement: The vertical distance between the highest point of the forehead and the lowest point of the chin. The subject should stand with their feet together and arms at their sides. The measurement should be taken to the highest point of the forehead, not the hair.

Head Width Measurement: The horizontal distance between the widest points of the head. The subject should stand with their feet together and arms at their sides. The measurement should be taken to the widest points of the head, not the ears.

Head Circumference Measurement: The distance around the head at the widest point. The subject should stand with their feet together and arms at their sides. The measurement should be taken around the head, not over the hair.

Hand Length Measurement: The vertical distance between the highest point of the wrist and the lowest point of the middle finger. The subject should stand with their feet together and arms extended straight out to the side. The measurement should be taken to the highest point of the wrist, not the ulnar styloid process.

Hand Width Measurement: The horizontal distance between the widest points of the hand. The subject should stand with their feet together and arms extended straight out to the side. The measurement should be taken to the widest points of the hand, not the fingers.

Hand Circumference Measurement: The distance around the hand at the widest point. The subject should stand with their feet together and arms extended straight out to the side. The measurement should be taken around the hand, not over the fingers.

Foot Length Measurement: The vertical distance between the highest point of the heel and the lowest point of the longest toe. The subject should stand with their feet together and arms at their sides. The measurement should be taken to the highest point of the heel, not the ball of the foot.

Foot Width Measurement: The horizontal distance between the widest points of the foot. The subject should stand with their feet together and arms at their sides. The measurement should be taken to the widest points of the foot, not the toes.

Foot Circumference Measurement: The distance around the foot at the widest point. The subject should stand with their feet together and arms at their sides. The measurement should be taken around the foot, not over the toes.

	NASA Engineering and Safety Center Technical Assessment Report	Document #: NESC-RP-12-00774	Version: 1.0
		Title: CAD Tools to Support Human Factors Design Teams	

5. VEL Lifting Tips and Task Demonstration (before session) –

VEL Lifting Training & Task Demonstration – DRAFT (8/12/2013)

Tips for lifting - discuss with participants before session begins:

1. Try to avoid holding heavy static loads as this can lead to low back pain
2. Limit the carry distance for heavy objects
3. Reduce weight and/or size of object(s) when possible
4. Lowering is preferred over lifting, pushing is preferred over pulling, and pulling is preferred over carrying an object.
5. Avoid twisting as much as possible during lifting
6. Get plenty of rest or recovery time when not lifting
7. Bend at the knees and use the legs to lift and not the back
8. Be sure to get a good grip on what you are lifting

Additional activities with participants before starting session begin:

1. Ask if there are any pre-exercise physical issues
2. Demonstrate safety, show them to be safe and explain the rules
3. Measure that they do not have to complete tasks that seem too difficult or risky
4. Remind them of the "Topic Collection - Participant Feedback" form that will be used after each task segment, that will be collecting a 3-5 min rating and additional notes
5. Consider the "Participant - Operator - HMI" form that includes some questions about personal interests

VEL Lifting Training & Task Demonstration – DRAFT (8/12/2013)

Tips for lifting - discuss with participants before session begins:

1. Try to avoid holding heavy static loads as this can lead to low back pain
2. Limit the carry distance for heavy objects
3. Reduce weight and/or size of object(s) when possible
4. Lowering is preferred over lifting, pushing is preferred over pulling, and pulling is preferred over carrying an object.
5. Avoid twisting as much as possible during lifting
6. Get plenty of rest or recovery time when not lifting
7. Bend at the knees and use the legs to lift and not the back
8. Be sure to get a good grip on what you are lifting

6. Data Collection: Participant Feedback (during session) - Used during task demonstration/lifting training and before starting the first capture.

Participant Feedback - Virtual Environments Lab (VEL), MSFC

PE # of _____ MSFC-VEL-Subject # _____
 Typically use 2-3 copies of this page (from PDF) Collected by: _____
 Collection date: _____

During motion capture session (after each recording segment)

>>> Task/Subtasks: _____ Capture segment # _____ (max 50 characters)

On a scale of 1 to 5, with 5 being most difficult, how would you rate that task? _____ (if between 1-5)

Which postures or motions did you find most difficult? _____ (max 50 characters)

>>> Researcher Observations & Comments: _____

>>> Task/Subtasks: _____ Capture segment # _____

Participant Feedback - Virtual Environments Lab (VEL), MSFC

PE # of _____ MSFC-VEL-Subject # _____
 Typically use 2-3 copies of this page (from PDF) Collected by: _____
 Collection date: _____

During motion capture session (after each recording segment)

>>> Task/Subtasks: _____ Capture segment # _____ (max 50 characters)

On a scale of 1 to 5, with 5 being most difficult, how would you rate that task? _____ (if between 1-5)

Which postures or motions did you find most difficult? _____ (max 50 characters)

>>> Researcher Observations & Comments: _____

>>> Task/Subtasks: _____ Capture segment # _____

Before Participant Leaves: Check that necessary data has been collected (e.g., signatures, written data, motion capture tasks and calibrations, video, participant personal photos in suit [if desired]) and thank them again for their time!

After the Session: Check in with team on session successes and improvements, high five each other, take a break, then transcribe written notes, and write session debrief—ideally, before the next session begins.

Enter data into corresponding spreadsheet files, deliver to database manager, and archive written versions in a secure project folder.

	NASA Engineering and Safety Center Technical Assessment Report	Document #: NESC-RP- 12-00774	Version: 1.0
Title: CAD Tools to Support Human Factors Design Teams		Page #: 71 of 142	

- ___ transcribe researcher notes
- ___ write debrief report, email to team and customer
- ___ enter data in spreadsheet files
- ___ deliver anthropometric data to VEL team ASAP
- ___ deliver data to database manager
- ___ archive written documentation

REFERENCE FILES (pdf and editable versions):

1. *Research Activity Description*

NESC-VEL_Research-Activity_Description_v1.doc

2. *Participant Consent Forms*

NESC-VEL-Study-Participant-Consent.pdf

NESC-VEL-Study-Participant-Consent.doc

3. *Data Collection: Demographics and Work Experience*

database-fields_demographics-2012-12.pdf

data-sessions-anthro-feedback-demographics-2013-08.xls

4. *Anthropometrics – Data Collection and Reference*

database-fields_anthropometrics-2012-12.pdf

data-sessions-anthro-feedback-demographics-2013-08.xls

AnthroCollection-Reference_MFSC_2012-12-14.pdf

5. *VEL Lifting Tips and Task Demonstration*

NESC-VEL-lifting-tips-task-demo.pdf

NESC-VEL-lifting-tips-task-demo.doc

6. *Data Collection: Participant Feedback*

database-fields_subject-feedback-2013-08.pdf

data-sessions-anthro-feedback-demographics-2013-08.xls



NASA Engineering and Safety Center Technical Assessment Report

Document #:
**NESC-RP-
12-00774**

Version:
1.0

Title:

CAD Tools to Support Human Factors Design Teams

Page #:
72 of 142

Anthropometric Measurement Form, Virtual Environments Lab

Collected by:	MSFC-VEL-Subject #:
Collection date:	Stature % (5, 50 or 95):
Collection notes:	Gender (M or F):
	other subject info:

>>measurements take without shoes; eight bolded items used in JACK software

		Measurements (cm)		*
Standing	Vertical	1 Stature		x
		2 Arm Length (resting at side, acromion to tip)		x
		3 Acromial Height (shoulder to floor)		x
		4 Waist Height (Navel)		x
		5 Overhead Fingertip Reach (set tool on box for height)		x
	Breadth	6 Biacromial Breadth (shoulder points)		x
		7 Bideltoid Breadth (shoulder outside)		x
		8 Hip Breadth (max pt, feet & knees together)		x
	Head	9 Head Breadth (max above ears)		x
		10 Head Height (chin to top)		x
		11 Head Length (forehead to back)		x
		12 Interpupil Distance (from above, rest on forehead)		x
	Tape	13 Chest Circumference (fullest part, pt of max respiration)		x
		14 Waist Circumference (Girth)		x
		15 Waist Circumference (Navel)		x
Sitting	Hand	16 Hand Length (wrist to tip)		x
		17 Hand Breadth (at knuckles)		x
	Vertical	18 Sitting Height (from sitting surface)		x
		19 Eye Height (from sitting surface)		x
		20 Sitting Acromial Height (midshoulder)		x
		21 Elbow Rest Height (sitting, 90 deg)		x
	Arms	22 Shoulder-Elbow Length (acromion-radiale, 90 deg)		x
		23 Elbow-Fingertip (Forearm - Hand Length)		x
	Waist	24 Abdominal Depth		x
	Legs	25 Buttock-Knee Length		x
		26 Thigh Clearance (to sit surface)		x
		27 Sitting Knee Height		x
	Feet	28 Ankle Height (lateral malleolus)		x
		29 Foot Length		x
		30 Foot Breadth, Horizontal		x
Wall	31 Functional Grip Reach (wall to first knuckle)		x	
Scale	32 Weight (kg)		x	

	NASA Engineering and Safety Center Technical Assessment Report	Document #: NESC-RP- 12-00774	Version: 1.0
Title: CAD Tools to Support Human Factors Design Teams		Page #: 73 of 142	

Motion Capture Subtask Sequences (Phase 1)

- Step in/out of hatch (for practice), emphasize arm drops and pauses & reversals

Configuration 1: Plywood part-task mock-up of hatch w/door, internal shelf, exterior GSE shelf

Segment 1: Hatch & LRU Tasks, Standing External to Vehicle

- T-Pose
- Approach and remove hatch door, set on GSE handling cart, PAUSE
- Take protrusion covers to door, PAUSE AT DOOR
- Lean in to install covers on internal protrusions, PAUSE BETWEEN
- Lift small LRU from cart shelf & bring to hatch
- Lean over to set LRU through hatch onto internal platform
- Stand & PAUSE
- Retrieve LRU and replace on shelf, PAUSE
- Lean in to remove covers on internal protrusions, PAUSE BETWEEN
- Return protrusion covers to shelf, PAUSE
- Remove door from shelf and close out hatch
- T-Pose

Configuration 1a: replace plywood door with acrylic version

- Repeat door removal and installation

Configuration 2: PVC wireframe hatch, internal shelf, exterior GSE shelf

Segment 2: Protrusion Covers and Ingress/Egress (no hatch door)

- T-Pose
- Take protrusion covers to door, PAUSE AT DOOR
- Lean in to install covers on internal protrusions, PAUSE BETWEEN
- Lift small LRU from cart shelf & bring to hatch
- Lean over to set LRU through hatch onto internal platform
- Stand & PAUSE
- Retrieve LRU and replace on shelf, PAUSE

	NASA Engineering and Safety Center Technical Assessment Report	Document #: NESC-RP- 12-00774	Version: 1.0
Title: CAD Tools to Support Human Factors Design Teams		Page #: 74 of 142	

- Lean in to remove covers on internal protrusions, PAUSE BETWEEN
- Return protrusion covers to shelf, PAUSE
- T-Pose

Configuration 3: Remove internal shelf (wooden box), exterior GSE shelf

Segment 3: Hatch Ingress/Egress

- T-Pose
- Step through hatch simulator, then step back out, PAUSE BETWEEN
- Repeat
- T-Pose

Configuration 4: GSE platform (table) with PVC hatch ring, exterior GSE shelf

Segment 4: LRU Operations – Standing Transfer

- Transfer LRU from GSE shelf to GSE platform
- Pass through LRU via GSE platform, PAUSE
- Walk around to be the “recipient”
- Retrieve the LRU from the table, PAUSE
- Reverse all actions

Configuration 5: GSE platform (table), LRU holder on floor, LRU on table

Segment 5: LRU Operations – Diving Board to Floor Transfer

- T-Pose “inside” vehicle, near battery LRU
- Stand facing LRU, PAUSE, assume lifting position, PAUSE
- Move LRU from diving board to holder box on floor
- Raise torso to resting position, PAUSE
- Stand and PAUSE
- Turn for T-Pose



NASA Engineering and Safety Center Technical Assessment Report

Document #:
**NESC-RP-
12-00774**

Version:
1.0

Title:

CAD Tools to Support Human Factors Design Teams

Page #:
75 of 142

Motion Capture Subtask Sequences (Phase 2)

Reference document: VEL-Mockups-Tasks-Aug-2013-a.ppt

<p>Task Sequences</p> <p>13</p>	<p>Five task segments</p> <p>Boxes, hatches & installations</p> <p>14</p>	<p>#1 remove door & transfer LRU</p> <p>15</p>
<p>Remove hatch & place on exterior GSE shelf</p> <p>16</p>	<p>#1 remove door & transfer LRU</p> <p>17</p>	<p>Transfer LRU battery to inside shelf & overhead</p> <p>18</p>
<p>#2 transfer LRU to overhead</p> <p>19</p>	<p>Transfer wireframe LRU to overhead</p> <p>20</p>	<p>#3 install hardware @ 3 locations</p> <p>21</p>
<p>Install hardware @ 3 locations</p> <p>22</p>	<p>Install hardware @ 3 locations</p> <p>23</p>	<p>Overhead post: low & high locations</p> <p>24</p>
<p>#4 transfer weighted door</p> <p>25</p>	<p>#5 step through hatch</p> <p>26</p>	<p>Hatch ingress/egress & close-out</p> <p>27</p>

	NASA Engineering and Safety Center Technical Assessment Report	Document #: NESC-RP- 12-00774	Version: 1.0
Title: CAD Tools to Support Human Factors Design Teams		Page #: 76 of 142	

Phase 2 Motion Capture Sessions - Example Task Checklist - Aug 2013 DRAFT

[Typical capture pattern: 1/2 1/2 2/2]

Segment A: Wireframe door

T-Pose > **Remove (Hatch to Shelf)** > T-pose
 T-Pose > **Install (Shelf to Hatch)** > T-pose
 T-Pose > **Remove & Install** > T-pose

Segment B: LRU Transfer - Exterior

T-Pose > **Install (Shelf to Box)** > T-pose
 T-Pose > **Remove (Box to Shelf)** > T-pose
 T-Pose > **Remove & Install** > T-pose

Segment C: LRU Transfer - Interior

T-pose > **Install (Shelf to Overhead > Hold > Overhead to Floor)** > T-pose
 T-pose > **Remove (reverse motions)** > T-pose
 T-pose > **Install & Remove (Shelf to Overhead > Hold > Overhead to Shelf)** > T-pose

- AND / OR -

T-pose > **Install (Shelf to Overhead)** > T-pose
 T-pose > **Remove (Overhead to Shelf)** > T-pose
 T-pose > **Remove & Install** > T-pose

Segment D: Interior Tool Connections

T-pose > Remove cover & **attach low connection** > T-pose
 T-pose > Remove cover & **attach middle connection** > T-pose
 T-pose > Remove cover & **attach overhead connection** > T-pose

Segment E: Weighted door

T-pose > **Remove (Hatch to Shelf)** > T-pose
 T-pose > **Install (Shelf to Hatch)** > T-pose
 T-pose > **Remove & Install** > T-pose

	NASA Engineering and Safety Center Technical Assessment Report	Document #: NESC-RP- 12-00774	Version: 1.0
Title: CAD Tools to Support Human Factors Design Teams			Page #: 77 of 142

Segment F: Electrical Cable Connections

T-pose > **attach Cable #1** > T-pose

T-pose > **attach Cable #2** > T-pose

T-pose > **attach Cable #3** > T-pose

Complete series once without step-up box platform and once with the platform

Filename of this document: Motion-Capture-Session-Checklist.docx



NASA Engineering and Safety Center Technical Assessment Report

Document #:
**NESC-RP-
12-00774**

Version:
1.0

Title:

CAD Tools to Support Human Factors Design Teams

Page #:
78 of 142

pg ___ of ___
use more pages if needed

Subject Feedback - Virtual Environments Lab (VEL), MSFC

MSFC-VEL-Subject #: _____
Collected by: _____
Collection date: _____

During motion capture session (after each recording segment)

>> Capture segment # ___ List major Task/Subtasks below:

_____ (max 50 characters)

On a scale of **1 to 5**, with 5 being most difficult, how would you rate that task?

_____ (# between 1-5)

Which postures or motions did you find most difficult?

_____ (max 50 characters)

Researcher Observations & Comments:

>> Capture segment # ___ List major Task/Subtasks below:

_____ (max 50 characters)

On a scale of **1 to 5**, with 5 being most difficult, how would you rate that task?

_____ (# between 1-5)

Which postures or motions did you find most difficult?

_____ (max 50 characters)

Researcher Observations & Comments:

>> Capture segment # ___ List major Task/Subtasks below:

_____ (max 50 characters)

On a scale of **1 to 5**, with 5 being most difficult, how would you rate that task?

_____ (# between 1-5)

Which postures or motions did you find most difficult?

_____ (max 50 characters)

Researcher Observations & Comments:



NASA Engineering and Safety Center Technical Assessment Report

Document #:
**NESC-RP-
12-00774**

Version:
1.0

Title:

CAD Tools to Support Human Factors Design Teams

Page #:
79 of 142

pg ___ of ___

Subject Feedback - Virtual Environments Lab (VEL), MSFC

use more pages if needed

MSFC-VEL-Subject #:

Collected by:

Collection date:

After entire motion capture session is complete

Where there specific motions or poses that were especially challenging? Which ones?

(max 50 characters)

What difficulties did you experience while doing the tasks?

(max 50 characters)

In an ideal situation, what modified or new features would these worksites have?

(max 250 characters)

Do you feel like your time in this session was well spent?

(max 250 characters)

Do you have ideas for how to improve these motion capture sessions?

(max 250 characters)

Analyst Summary - specific subtasks or elements described as difficult:

(max 50 characters)

List corresponding numbers or codes:

(max 50 characters)



Title:

CAD Tools to Support Human Factors Design Teams

Page #:
80 of 142

Appendix D. Motion Capture – User Guide and Lab Processes

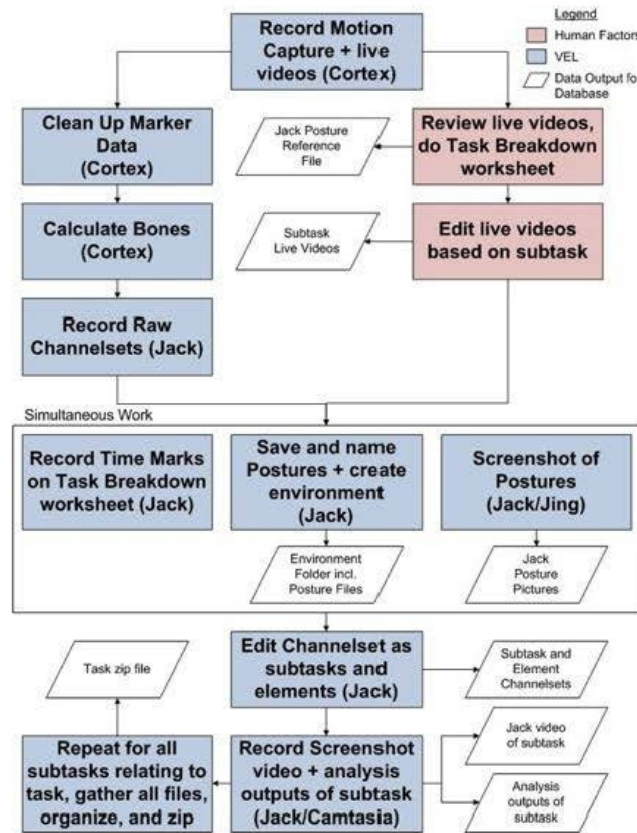

The diagram above shows a simple work breakdown of the approach to creating data necessary for the Primitives database. The scope of the work breakdown includes the activities directly associated with motion capture recording and the JACK software outputs.

The diagram does not show the calibration effort that takes place prior to the motion capture session. The motion capture hardware and software must be calibrated to have confidence in the data collected. The motion capture cameras are aligned to ensure optimal cover of the work volume. Also, the focus of each camera is checked. The "as run" procedure is outlined in the following figure. The VEL camera alignment and focus procedure is performed when adjustments are needed for the cameras. If a

	NASA Engineering and Safety Center Technical Assessment Report	Document #: NESC-RP- 12-00774	Version: 1.0
Title: CAD Tools to Support Human Factors Design Teams		Page #: 81 of 142	

camera is added or removed from service this procedure would be required to be performed for the motion capture sessions to occur.

Prior to each motion capture session, the VEL motion capture software calibration procedure is followed. The “as run” procedure sheet is also in the following diagram. It established the camera locations within the working volume with a clean view. Several cameras are positioned within the field of view of other cameras. The areas of the field of views are “masked” which prevents the software from attempting to distinguish these areas as markers. Measure estimates are recorded to quantify the calibration of the software. The “as run” sheets are kept in a calibration log for maintenance purposes.



NASA Engineering and Safety Center Technical Assessment Report

Document #:
**NESC-RP-
12-00774**

Version:
1.0

Title:

CAD Tools to Support Human Factors Design Teams

Page #:
82 of 142

VEL Camera Alignment and Focus Procedure

Date Performed _____ Reason Performed _____

Who _____

- 1) Turn on power supplies to cameras (20 minute warm up period is recommended) _____
- 2) Load Calibration file and set working directory
 - a. Quick files/select directory/Set as working directory
 - b. Calibration file loaded from: _____
 - c. Calibration file saved to: _____
 - d. Working Directory selected: _____
- 3) Check each cameras FOV with respect to the camera coverage volume (ref. Chapter 2 of Cortex 3.0 Reference Manual)
 - a. From the "3d Display Show Properties" window, select "Cam Field-of-view" and "Volume" check boxes to display camera coverage's (page 2-2, Figure 2-1 of Cortex 3.0 Reference Manual)
 - b. Select a single camera to display its field-of-view against the desired volume
 - c. Adjust camera mounts if needed (repeat until cameras have been evaluated)
 - d. Record Cameras Adjusted: _____
- 4) Check Focus of each camera
 - a. Change the display to the 2D camera view (Data View option)
 - b. Select camera view of camera under evaluation.
 - c. Place "Camera Focus Card" from Motion Analysis on floor with face of card perpendicular to camera's centerline ray.
 - d. Evaluate the image displayed by the camera: reflective spots on the card should be displayed as black blobs with a red cross hair marking the centroid of the blob. The bottom two rows of the card should be visible.
 - e. If needed, adjust the focus of the camera until the camera displays the card's reflective spots (bottom two rows) with red cross hairs.
 - f. Record camera number of those cameras adjusted _____
 - i. _____
 - ii. _____
 - g. Repeat steps 4b through 4f until cameras are evaluated.
- 5) Record estimated focal lengths of each camera:



NASA Engineering and Safety Center Technical Assessment Report

Document #:
**NESC-RP-
12-00774**

Version:
1.0

Title:

CAD Tools to Support Human Factors Design Teams

Page #:
83 of 142

VEL Motion Capture Software Calibration Procedure

Date Performed _____ Reason Performed _____

Who _____

- 1) Turn on power supplies to cameras (20 minute warm up period is recommended) _____
 - a. Continuation of Camera Alignment and Focus Procedure: _____
- 2) Load Calibration file and set working directory
 - a. Calibration file loaded from: _____
 - b. Working Directory selected: _____
- 3) Place L Frame marker set in the marked area (near center of capture volume) on floor: _____
- 4) Check each camera view for the correct numbers of markers (black blob with red crosshair depicting centroid). (Data Views/2D Camera View/All On: will result in the display of all camera views on the main display).
 - a. Mask any extra markers that appear in the views; Masks added to camera views: _____
 - b. Adjust markers on L Frame marker set if centroids are not depicted (rotate marker 90 degrees until camera view display 4 markers (number of markers is in the bottom left of view): Cameras initially displaying less than 4 markers with centroids: _____
- 5) Perform Seed Calibration: Calibration button (located on the main screen bottom left) will start the Calibration Wizard. Use the "Initial Calibration" option to calibrate.
 - a. Check for "clean volume" _____
 - b. "Next" button will perform "Seed" calibration (sets global frame coordinates) _____
- 6) Perform Wand Calibration: continue using Calibration Wizard ("Next" button)
 - a. Remove L Frame marker set from volume _____
 - b. Cortex operator will coordinate with wand waver when to start execution of wand calibration: wand length: _____ collection time: _____
 - c. Wand should be waved with respect to the each coordinate axis while traversing the motion capture volume (up/down, in/out, and side to side) until all of the volume has been passed through by the wand or until time has expired. _____
 - d. Perform analysis on wand data ("Next" button): _____
Calculated wand length: _____ Calculated deviation: _____
- 7) Floor Calibration is not accomplished; Depress "Finish" button on Calibration Wizard display _____
- 8) Save Set-up (File/Save Set-up):
 - a. Current working directory: _____



NASA Engineering and Safety Center Technical Assessment Report

Document #:
**NESC-RP-
12-00774**

Version:
1.0

Title:

CAD Tools to Support Human Factors Design Teams

Page #:
84 of 142

Appendix E. Data Organization and Naming

Table E-1. Motion Segmentation and Database Fields Worksheet (time codes, posture extraction)

Video time (min:sec)	T-pose / Mocap reference time	checkpoint type	posture element? (x = yes)	Elements (bold) & checkpoint descriptions	JACK Posture
reference video: 20121214_103423_right-side_USE_wooden-and-plexi-hatch.mp4					
1:54	0:00			T-pose, start of arms dropping	
1:55	0:01	start		arms down, stepping towards hatch	
1:58	0:04	start		Grasping door before lift	
1:59	0:05		x	bent over & lifting door from hatch	P01a
2:00	0:06		x	holding door & turning	P01b
2:03	0:09	stop/start	x	resting door on GSE shelf before standing	P01c
2:04	0:10	start	x	grasping battery LRU on GSE shelf	P01a
2:05	0:11		x	LRU lifted chest height & turning	P01b
2:09	0:15		x	LRU inserted through hatch & lowering, pre-release	P01c
2:11	0:17	stop/start		arms dropped after task, standing straight	
2:13	0:19		x	bent over & lifting LRU from inside hatch	P02a
2:17	0:23	stop	x	LRU released on GSE shelf	P02b
2:18	0:24	start	x	grasping door to lift from GSE shelf	P02a
2:20	0:26		x	holding door & turning	P02b
2:23	0:29		x	placing door against hatch	P02c
2:28	0:34	stop		arms dropped	

The screenshot shows a large, multi-column spreadsheet. A green rectangular box highlights a section of the data, likely corresponding to the information in Table E-1. The spreadsheet contains various columns, some with colored headers (orange, green, blue, purple, red, yellow), and rows of data with numerical and text entries.



NASA Engineering and Safety Center Technical Assessment Report

Document #:
NESC-RP-12-00774

Version:
1.0

Title:

CAD Tools to Support Human Factors Design Teams

Page #:
85 of 142

Table E-2. Motion Segmentation and Database Fields Worksheet (element-to-task hierarchy)

Element file name (postures)	Element (these are also search keywords)	Subtask	Task
	stand, step, bend	remove door, hatch to shelf	attach/remove hatch from stage wall
	stand, bend, reach	remove door, hatch to shelf	attach/remove hatch from stage wall
sub-005-hatch-02-01a.post	stand, bend, lift	remove door, hatch to shelf	attach/remove hatch from stage wall
sub-005-hatch-02-01b.post	stand, transfer	remove door, hatch to shelf	attach/remove hatch from stage wall
sub-005-hatch-02-01c.post	stand, bend, lower	remove door, hatch to shelf	attach/remove hatch from stage wall
sub-005-LRU-01-01a.post	stand, lift	install LRU, shelf to hatch	remove/replace LRU, location inside hatch
sub-005-LRU-01-01b.post	stand, turn, transfer	install LRU, shelf to hatch	remove/replace LRU, location inside hatch
sub-005-LRU-01-01c.post	bend, reach, lower	install LRU, shelf to hatch	remove/replace LRU, location inside hatch
	bend, stand	remove LRU, hatch to shelf	remove/replace LRU, location inside hatch
sub-005-LRU-01-02a.post	bend, reach, lift	remove LRU, hatch to shelf	remove/replace LRU, location inside hatch
sub-005-LRU-01-02b.post	stand, lower	remove LRU, hatch to shelf	remove/replace LRU, location inside hatch
sub-005-hatch-02-02a.post	bend, lift	install door, shelf to hatch	attach/remove hatch from stage wall
sub-005-hatch-02-02b.post	stand, transfer	install door, shelf to hatch	attach/remove hatch from stage wall
sub-005-hatch-02-02c.post	bend, lower	install door, shelf to hatch	attach/remove hatch from stage wall
	bend, stand	install door, shelf to hatch	attach/remove hatch from stage wall

The screenshot shows a large table with multiple columns. A green rectangular box highlights a section of the table, and a vertical green line extends upwards from the top of this box to the 'Element (these are also search keywords)' column of the summary table above.



NASA Engineering and Safety Center Technical Assessment Report

Document #:
**NESC-RP-
12-00774**

Version:
1.0

Title:

CAD Tools to Support Human Factors Design Teams

Page #:
86 of 142

Table E-3. Motion Segmentation and Database Fields Worksheet (.zip files downloaded per element)

ZIP files downloaded - per Element			
Function	ENV zip	Channelset zip	Media zip
Open & Secure Stage Hatch			
Open & Secure Stage Hatch			
Open & Secure Stage Hatch	sub-005-hatch-02 env	sub-005-hatch-02-01 chset	sub-005-hatch-02-01 media
Open & Secure Stage Hatch	sub-005-hatch-02 env	sub-005-hatch-02-01 chset	sub-005-hatch-02-01 media
Open & Secure Stage Hatch	sub-005-hatch-02 env	sub-005-hatch-02-01 chset	sub-005-hatch-02-01 media
LRU Servicing	sub-005-LRU-01 env	sub-005-LRU-01-01 chset	sub-005-LRU-01-01 data
LRU Servicing	sub-005-LRU-01 env	sub-005-LRU-01-01 chset	sub-005-LRU-01-01 data
LRU Servicing	sub-005-LRU-01 env	sub-005-LRU-01-01 chset	sub-005-LRU-01-01 data
LRU Servicing			
LRU Servicing	sub-005-LRU-01 env	sub-005-LRU-01-02 chset	sub-005-LRU-01-02 data
LRU Servicing	sub-005-LRU-01 env	sub-005-LRU-01-02 chset	sub-005-LRU-01-02 data
Open & Secure Stage Hatch	sub-005-hatch-02 env	sub-005-hatch-02-02 chset	sub-005-hatch-02-02 media
Open & Secure Stage Hatch	sub-005-hatch-02 env	sub-005-hatch-02-02 chset	sub-005-hatch-02-02 media
Open & Secure Stage Hatch	sub-005-hatch-02 env	sub-005-hatch-02-02 chset	sub-005-hatch-02-02 media

The screenshot shows a complex spreadsheet with multiple columns and rows. A green rectangular box highlights a specific area in the middle-right portion of the spreadsheet, containing several rows of data. The spreadsheet appears to be a detailed breakdown of the data presented in the summary table above, with columns likely corresponding to the 'Function', 'ENV zip', 'Channelset zip', and 'Media zip' categories.

	NASA Engineering and Safety Center Technical Assessment Report	Document #: NESC-RP-12-00774	Version: 1.0
		Title: CAD Tools to Support Human Factors Design Teams	

Appendix F. NASA Program Risk Scorecard and Ratings Table

Table F-1. Risk Scorecard with Definitions

LIKELIHOOD RATING (LR)	
5 Very High	Qualitative: Nearly certain to occur. Controls have little or no effect. Quantitative: $10^{-1} < P$ (for risks with primary consequence on Human Safety - Personnel) or $P > 50$ percent (for risks with primary consequence on Cost, Schedule, or Performance).
4 High	Qualitative: Highly likely to occur. Controls have significant uncertainties. Quantitative: $10^{-2} < P \leq 10^{-1}$ (for risks with primary consequence on Human Safety-Personnel) or 33 percent $< P \leq 50$ percent (for risks with primary consequence on Cost, Schedule or Performance)
3 Moderate	Qualitative: May occur. Controls exist with some uncertainties. Quantitative: $10^{-3} < P \leq 10^{-2}$ (for risks with primary consequence on Human Safety-Personnel) or 10 percent $< P \leq 33$ percent (for risks with primary consequence on Cost, Schedule, or Performance)
2 Low	Qualitative: Not likely to occur. Controls have minor limitations/uncertainties. Quantitative: $10^{-4} < P \leq 10^{-3}$ (for risks with primary consequence on Human Safety-Personnel) or 1 percent $< P \leq 10$ percent (for risks with primary consequence on Cost, Schedule, or Performance)
1 Very Low	Qualitative: Very unlikely to occur. Strong Controls in Place. Quantitative: $P \leq 10^{-5}$ (for risks with primary consequence on Human Safety-Personnel) or $P \leq 1$ percent (for risks with primary consequence on Cost, Schedule, or Performance).

L I K E L I H O O D	5	10	16	20	23	25
	4	7	13	18	22	24
	3	4	9	15	19	21
	2	2	6	11	14	17
	1	1	3	5	8	12
		1	2	3	4	5
CONSEQUENCE						



NASA Engineering and Safety Center Technical Assessment Report

Document #:
**NESC-RP-
12-00774**

Version:
1.0

Title:

CAD Tools to Support Human Factors Design Teams

Page #:
88 of 142

Table F-2. Safety Ratings Table

CONSEQUENCES		1	2	3	4	5
SAFETY	Personnel	Minor injury not requiring first-aid treatment, minor crew discomfort	Injury requiring first-aid treatment, moderate crew discomfort	Injury, illness or incapacitation requiring emergency or hospitalization treatment	Severe injury or illness requiring extended hospital/Medical treatment	Loss of life or permanently disabling injury
	Facilities, Equipment, Assets	Minor damage or non-essential flight assets	Minor damage to Program Critical assets, Major damage to non-essential assets	Minor damage to flight/ Ground assets, Major damage to Program critical assets, or loss of non-essential assets	Loss of mission, Major damage to Flight/Ground Assets; doesn't meet criteria for catastrophic hazard, or Loss of Program Critical Asset	Loss of Flight/Ground Assets or Loss of vehicle prior to completing its mission
	Environmental	Negligible OSHA/ EPA violation – non reportable	Minor reportable OSHA/EPA violation	Moderate OSHA/EPA violation which requires immediate remediation	Major OSHA/EPA violation causing temporary stoppage	Serious or repeat OSHA/EPA violations resulting in action terminating program
PERFORMANCE	Requirements	Negligible impact to requirements/ design margins	Minor impact to requirements/ design margins	Moderate impact to requirements/design	Major impact to requirements/design margins	Technical goals not achievable with existing engineering capabilities/technologies
	Operations	Negligible impact to mission operations	Minor impact to operations – workarounds available	Moderate impact to operations – workarounds available	Failure to achieve major mission objectives	Contingency Abort
	Supportability	Temporary usage loss or LOCM of non-flight critical asset	Permanent usage loss or LOCM of non-flight critical asset	Temporary usage loss or LOCM of major element(s) of flight vehicle or ground facility	Permanent usage loss or LOCM of major element(s) of flight vehicle or ground facility	Inability to support further flight operations
Cost		≤\$100K	>\$100K but ≤\$1M	>\$1M but ≤\$10M	>\$10M but ≤\$50M	>\$50M
Schedule		Negligible schedule impact	Minor overall schedule impact (no impact to critical path)	≤1 month impact to critical path/milestones	>1 and ≤5 month impact to critical path/milestones	>5 month impact to critical path/milestones or possible program cancellation

	NASA Engineering and Safety Center Technical Assessment Report	Document #: NESC-RP-12-00774	Version: 1.0
Title: CAD Tools to Support Human Factors Design Teams		Page #: 89 of 142	

Appendix G. Database Design Structure and Software

Data collected at the VEL is organized into a folder and compressed into a .zip file (data packet) for storage into the database. These data packets are associated with text data in the database that describes the functions, tasks, sub-tasks and elements. The database is a relational database developed using MySQL. It is organized into tables that store the data (there is a table for functions, tasks, sub-tasks, elements, subjects, researchers, data packets, pictures, video, ANSUR data, etc.), and is relational because fields in each table are linked to appropriate fields in other tables: the functions table is linked to all the tasks that are associated with the function, links exist between the tasks, sub-tasks and elements. Elements are linked to data packets with pictures, videos, subjects and all data that support the motion capture sequence.

There are two MySQL databases required for the site to function properly, one for storing posture and motion data, and one for handling security and authorized user authentication. The two databases are separate from each other and both serve independent functions. They do not share information between them, but integration does occur on the front-end web page, which calls each database as required. The authentication database is checked on each page load to verify that the person accessing the data is an authorized user and is logged in, and the postures and motion database is called when needed to display relevant data within the loaded pages.

The Postures & Motions Database is named HFEVEL in MySQL. Below is a list of the 14 tables comprising the HFEVEL:

function	researcher	video
task	sub_res	videopict
sub_task	jack	ansur
element	jackpict	anthro
subject	jackvid	

At the time of this report, HFEVEL has the following data:

- element contains 37 records
- sub_task contains 9 records
- task contains 4 records
- function contains 2 records
- jack (data packets) contains 7 records

The current implementation of HFEVEL stores the data packets with video and picture files in the database. An alternative was to store these large files outside of the database and only store references to the files name and location in the database. There are tradeoffs to each approach, the first (storing in database) can slowdown the response of the database as the amount of data stored is increased. The second approach (storing the data outside of the database) will maintain the speed of the database however the location of the external data needs to be maintained separately from the database and synchronized with it or the database will not be able to locate the data. It is possible to reconfigure the database from one scheme to the other if the need arises. HFEVEL can store, retrieve and download data packets and video files up to 60 MB per file.



NASA Engineering and Safety Center Technical Assessment Report

Document #:
**NESC-RP-
12-00774**

Version:
1.0

Title:

CAD Tools to Support Human Factors Design Teams

Page #:
90 of 142

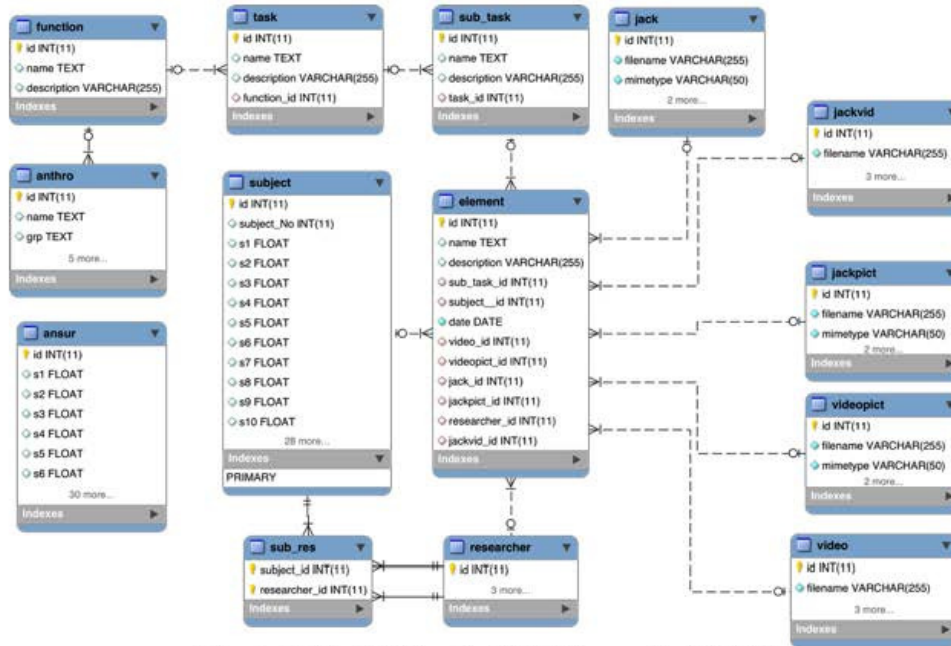

Extended Entity-Relationship (EER) Diagram for HFEVEL

The MySQL security database is named “vel_auth” and handles the back-end needs to implement a PHP based user authentication system. The vel_auth database, like the HFEVEL database, is relational and contains two tables, which are as follows:

- 1.) vel_users – Stores a user list for HFEVEL database access and relevant information about each user.
- 2.) user_session – Stores PHP based sessions that are generated upon a successful login and the information required to run said session.

The authentication system works by using PHP based sessions, which are generated upon a successful login, and will expire when the browser is closed or after thirty minutes of inactivity. Except for the login page, before each web page will load it first checks to make sure there is an existing session for the user seeking to gain access. The session stores relevant info about each user such as their username, real name, email, organization, and last access time. This makes it possible to track who is accessing data, what data they accessed, and when it was requested. By requiring each user to have a generated session before accessing web site data we can ensure the integrity of our data is maintained, and that our data remains secure.

vel_users: Currently there are two records, or users stored in the vel_users table, the admin user

	NASA Engineering and Safety Center Technical Assessment Report	Document #: NESC-RP-12-00774	Version: 1.0
Title: CAD Tools to Support Human Factors Design Teams		Page #: 91 of 142	

account and a test user account. Each user entry contains seven columns or data fields, and each field is required for a user account to be verified. Accounts can exist in un-verified form but are not able to access any web site data. Each row in the table represents a single user entry and contains the following columns of data:

- 1.) **user_id** – The **user_id** field is an auto incremented integer index which assigns an ID number to each user entry as it is created. This is used within the PHP authentication code to work with multiple users, and also to check if a specific user is the administrator or not (e.g., 1).
 - a.) The first user (**user_id** = 1) is the admin. Any user with a **user_id** not equal to 1 is treated as a normal user.
 - b.) The **user_id** field has a capacity of up-to 11 integers, allowing for plenty of user accounts to be created.

- 2.) **Username** – The **username** field represents the login username for a specific user, which is paired to the associated **user_id** (e.g., veladmin).
 - a.) The **username** field has 20 character capacity, and this constraint is checked for in the login function to ensure that a buffer overflow style of attack is not possible for this data field.

- 3.) **password** – This field contains the login password which is paired with a **username** for each **user_id** creating a valid **username/password** login combination. No plain text passwords are stored in this field; each one is hashed at the point of user entry, making it impossible for anyone including the site administrator to see a user's password (e.g., a5b9aadf42e3ca4404b21018cd1d24cec6c4a547).
 - a.) The hashing function used is called SHA1 and uses a 256 bit encryption algorithm to hash user passwords. No plain text passwords are stored anywhere on the web site or database.
 - b.) There is a 40-character capacity for storing encrypted passwords in the database. This allows the user to generate a password up to 20 characters in length. As above with the **username** field, the length of the entered password is checked in the login function to prevent buffer overflow attacks on this field of entry.

- 4.) **real_name** – This field stores the real name of the user and associates it with the **user_id** and **username** fields. (e.g., Trey Perry)
 - a.) The **real_name** field has a 100 character capacity, which should allow for even the longest names to be entered completely.

	NASA Engineering and Safety Center Technical Assessment Report	Document #: NESC-RP-12-00774	Version: 1.0
Title: CAD Tools to Support Human Factors Design Teams		Page #: 92 of 142	

5.) email – This field contains the email address for a user and associates it with the appropriate user_id and username. (e.g., Trey.Perry@nasa.gov)

a.) As with the above real_name field, the email field has a 100 character capacity with the intention of allowing long emails to be entered completely.

6.) org – This is the organization the associated user belongs to. Once again this information is associated with the appropriate user_id and username combination (e.g., EV74).

a.) The org field has a 10 character capacity, which should allow for proper entry of user organizations using abbreviations.

7.) active – This is a simple Boolean field to verify if a specific user account is activated. Before a user can gain access to the web site, they must first request an account, and then the account must be approved by the site admin before access is granted. User accounts can exist in the vel_users table of the vel_auth database in an un-verified or inactive form. (e.g., 1)

a.) If the active field is equal to 0, the user has not yet approved for access.

b.) If the active field is equal to 1, the user has been approved for access.

c.) The active field has a 1 integer capacity as it only stores a single variable integer.

With the vel_users table in place, sessions may be generated when a user is authenticated and any user logged in with a session will be allowed to access the different pages and data stored on the web site. For the session PHP code to function, there are a few data fields that require storage space in the database. A table in the vel_auth database named user_session has been created to meet these storage needs.

user_session: This table has a variable number of records depending on how many people are logged into the site at a single given time. The user_session table in the database is "cleaned" after each session expires, thus if nobody is logged in this table will be empty. As with the above vel_users table, there are several data fields each representing a column in the table. An individual session entry represents a row, with all columns required for the session to function properly.

1.) session_id – The session_id field contains a unique 40 character ID assigned to each

	NASA Engineering and Safety Center Technical Assessment Report	Document #: NESC-RP-12-00774	Version: 1.0
Title: CAD Tools to Support Human Factors Design Teams		Page #: 93 of 142	

login, or session. This ID is automatically generated and is alphanumeric (e.g., a5b9aadf42e3ca4404b21018cd1d24ceec6c4a547).

- a.) A session will time-out after thirty minutes of inactivity, or when the browser window is closed.
 - b.) A user can only have one generated session at any given time. This makes it so that the same user cannot be logged in twice, and fixes a security concern surrounding sharing accounts.
 - c.) Sessions will not generate for users who are not yet approved, or for users who do Not have an account entered into the vel_users table of the vel_auth database. This helps to ensure that only users who have been authorized can access the HFEVEL database.
 - d.) The session_id field has a 40 character capacity, which is required by the algorithm that automatically generates the session ID.
- 2.) data – This field contains the storage space for session data and is associated with a specific session_id. Each session requires several pieces of data to function properly, and includes things such as the user’s information and the last time the user was active on the web site.

```
(e.g.,a:9{s:11:"last_active";i:1375155161;s:7:"created";i:1375155161;s:7:"user_id";s:1:"1";s:8:"username";s:8:"veladmin";s:9:"real_name";s:10:"Trey Perry";s:5:"email";s:19:"Trey.Perry@NASA.gov";s:3:"org";s:4:"EV74";s:6:"active";s:1:"1";s:8:"is_admin";b:1;})
```

- a.) All the information stored in the data field is delimited by semi-colons. This allows for automatic parsing of the data by the PHP SessionHandler code that accesses it. Data fields stored include: last_active, created, user_id, username, real_name, email, org, active, is_admin. This allows for checks and logging to be performed in the PHP authentication code such as; who accessed what/when, when was the user last active (for time-out purposes), when was the session created, is the specific user in question the admin?
- b.) A special "text" data-type is used for storing the session data. The "text" data-type is only limited in size by the amount of available data storage and communication buffers. These values are set during the MySQL server configuration during setup, and they can be adjusted as needed. This allows flexibility in storing session data, as the size of each entry will be variable because each user’s information (name, email, ...) will be a different length.

	NASA Engineering and Safety Center Technical Assessment Report	Document #: NESC-RP- 12-00774	Version: 1.0
Title: CAD Tools to Support Human Factors Design Teams		Page #: 94 of 142	

3.) session_date – This field contains the creation date and time of a session and paired with a specific session ID. (e.g., 1375155161)

- a.) The session_date field is used to "time-out" sessions after 30 minutes of inactivity.
- b.) This field has a 10 integer capacity, which is what is required to store date and time in the datetime format used within the PHP authentication code.

These two tables when used with PHP session handling code create the framework for a basic, but functional user authentication system. Other options for security are being explored (e.g., allowing NASA users to login with their NDC credentials). Currently a separate authentication system is desired to allow access to non-NASA users.

The dynamic server-side implementation of the Web site allows for complex functioning of the database through the user's interaction with the Web page. A block diagram of the server-side dynamic web page functioning is shown below.



NASA Engineering and Safety Center Technical Assessment Report

Document #:
**NESC-RP-
12-00774**

Version:
1.0

Title:

CAD Tools to Support Human Factors Design Teams

Page #:
95 of 142

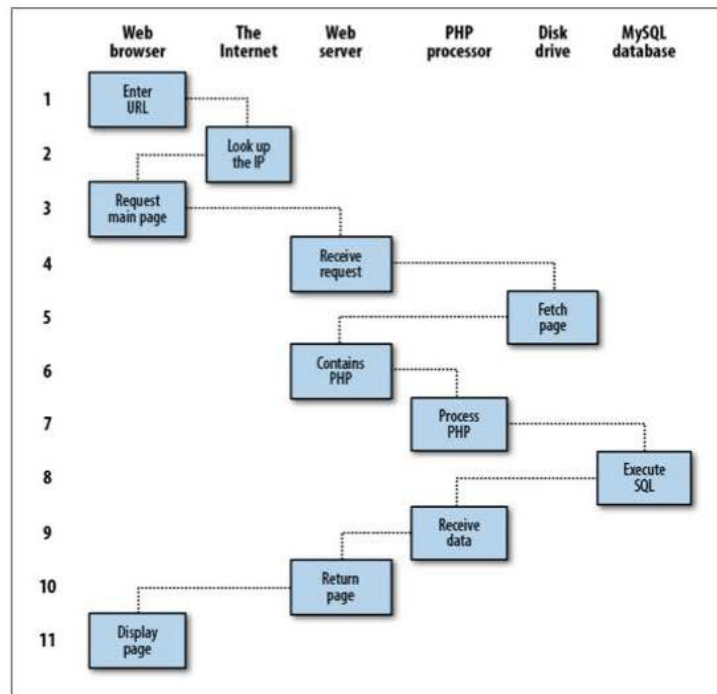

Block Diagram of the Server-side Dynamic Web Page Functioning

Software Used

HyperText Markup Language (HTML) is the language used to create web page documents. HTML is not a programming language; it is a markup language, which means it is a system for identifying and describing the various components of a document such as headings, paragraphs, and lists.

Cascading Style Sheets (CSS) describe how the HTML content in a web page should look. Fonts, colors, background images, line spacing, and page layout are controlled with CSS.

JavaScript is a scripting language that is used to add interactivity and behaviors to web pages. JavaScript is used to manipulate the elements on the web page, the styles applied to them, or even the browser itself.

Apache 2.2.23 Server - delivers web pages on a request to clients using the Hypertext Transfer Protocol (HTTP). This means delivery of HTML documents and any additional content that may be included by a document, such as images, style sheets and scripts.

	NASA Engineering and Safety Center Technical Assessment Report	Document #: NESC-RP-12-00774	Version: 1.0
Title: CAD Tools to Support Human Factors Design Teams		Page #: 96 of 142	

PHP 5.4.10 is an open source server-side scripting language designed for Web development to produce dynamic Web pages.

MySQL 5.5.29 is an open source database

Adobe Dreamweaver is a web design and development application that provides a visual WYSIWYG (what you see is what you get) editor (referred to as the Design view) and a code editor with standard features (e.g., syntax highlighting, code completion, and code collapsing) and more sophisticated features (e.g., real-time syntax checking and code introspection) for generating code hints to assist the user in code generation. The Design view facilitates rapid layout design and code generation as it allows users to quickly create and manipulate the layout of HTML elements. Dreamweaver features an integrated browser for previewing developed webpages in the program's own preview pane in addition to allowing content to be open in locally installed web browsers. It provides transfer and synchronization features, the ability to find and replace lines of text or code by search terms or regular expressions across the entire site, and a template feature that allows single-source update of shared code and layout across entire sites without server-side includes or scripting.

BBEdit is a professional HTML and text editor for the Macintosh.

Eclipse for PHP Developers (Build-Id: 20100617-1415) is an integrated development environment (IDE) for development of PHP and HTML web pages. Eclipse includes a file structure browser, PHP development tools (PDT), a web tools platform, Mylyn support, and many other useful features. It includes many standard features such as syntax checking and highlighting, auto-completion of fields, code hints, error checking, and file management features. It is similar to Dreamweaver, which is described above, but is not a “what you see is what you get” (WYSIWG) editor such as Dreamweaver is. Instead Eclipse focuses more on features such as code auto-completion, syntax checking, and error checking using its built-in PHP interpreter to make up for the lack of a visual editing feature. It is used in conjunction with a MAMP server located on a NASA issued ACES MacBook Pro to provide the visual representation needed in a web development environment. The site is hosted locally and can be refreshed as needed to display the results of changes made in any browser of the developers choosing. This allows for a “sandboxed” development approach where development work in-progress can be kept separated from the published web site.

	<h1>NASA Engineering and Safety Center Technical Assessment Report</h1>	Document #: NESC-RP-12-00774	Version: 1.0
Title: <h2>CAD Tools to Support Human Factors Design Teams</h2>		Page #: 97 of 142	

Appendix H. Database Website Interface – July 31, 2013 version

PMD Sample Pages: Element Search, Subtask Table, and Anthropometric Reference Page

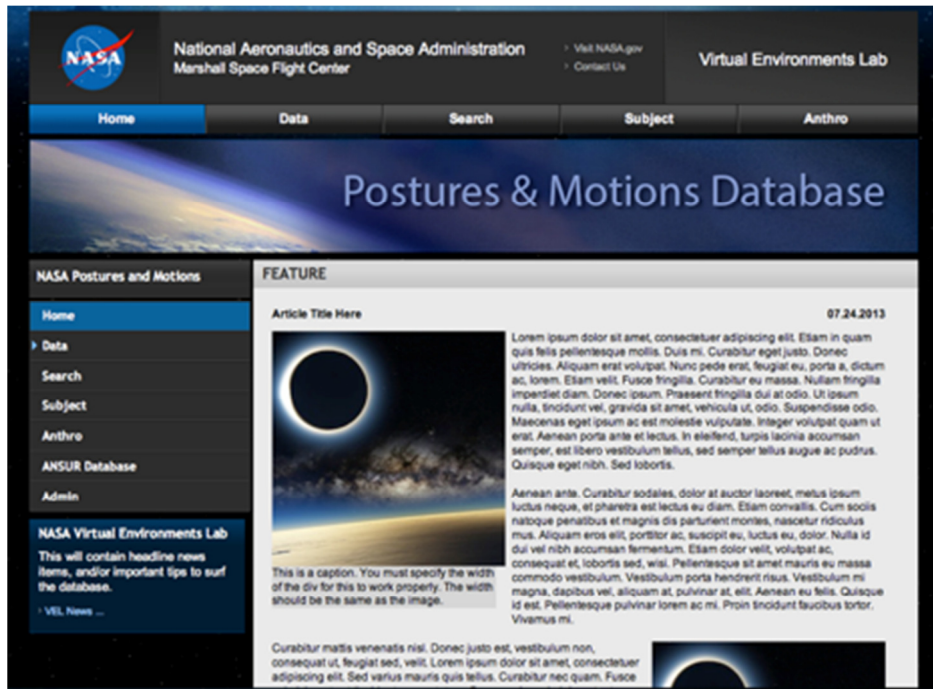
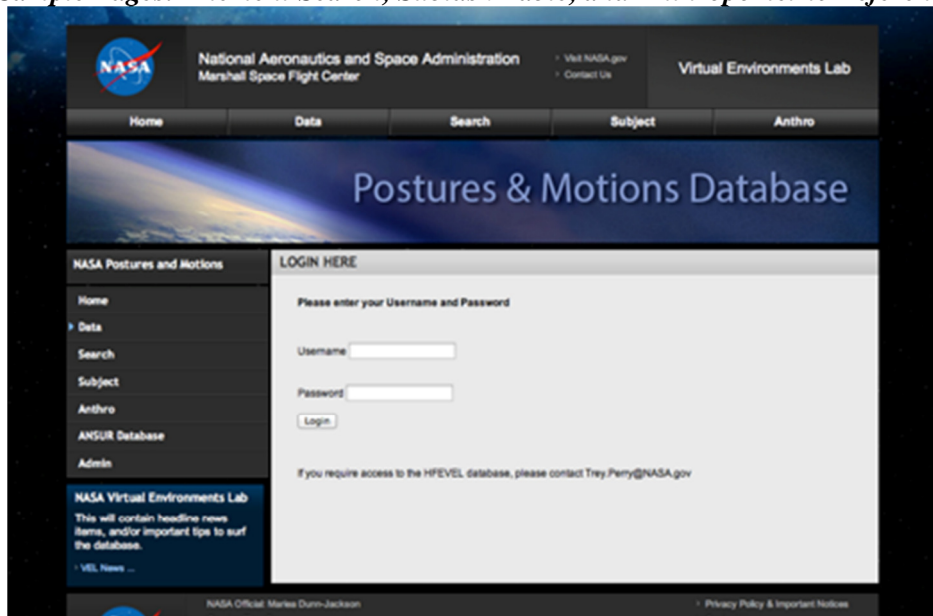



NASA Engineering and Safety Center Technical Assessment Report

Document #:
**NESC-RP-
12-00774**

Version:
1.0

Title:

CAD Tools to Support Human Factors Design Teams

Page #:
98 of 142

NASA Postures and Motions Database

FUNCTIONS

Name:
Open & Secure Stage Hatch LRU Servicing

NASA Postures and Motions Database

TASKS

Function	Task
Open & Secure Stage Hatch	enter/exit vehicle hatch
Open & Secure Stage Hatch	attach/remove hatch from stage wall
Open & Secure Stage Hatch	attach/remove hatch opening protection devices
LRU Servicing	remove/replace LRU, location inside hatch
LRU Servicing	remove/replace LRU, floor location
LRU Servicing	transfer LRU, through hatch



NASA Engineering and Safety Center Technical Assessment Report

Document #:
**NESC-RP-
12-00774**

Version:
1.0

Title:

CAD Tools to Support Human Factors Design Teams

Page #:
99 of 142

NASA Postures and Motions Database

Sub-Tasks Table:

Function	Task	Sub-Task
Open & Secure Stage Hatch	enter/exit vehicle hatch	hatch ingress, step-through
Open & Secure Stage Hatch	enter/exit vehicle hatch	hatch ingress, step-through
Open & Secure Stage Hatch	enter/exit vehicle hatch	hatch ingress, step-through
Open & Secure Stage Hatch	enter/exit vehicle hatch	hatch ingress, step-through
Open & Secure Stage Hatch	enter/exit vehicle hatch	hatch ingress, step-through
Open & Secure Stage Hatch	enter/exit vehicle hatch	hatch ingress, step-through
Open & Secure Stage Hatch	enter/exit vehicle hatch	hatch ingress, step-through
Open & Secure Stage Hatch	enter/exit vehicle hatch	hatch ingress, step-through
Open & Secure Stage Hatch	enter/exit vehicle hatch	hatch ingress, step-through
Open & Secure Stage Hatch	enter/exit vehicle hatch	hatch ingress, step-through
Open & Secure Stage Hatch	enter/exit vehicle hatch	hatch ingress, step-through
Open & Secure Stage Hatch	enter/exit vehicle hatch	hatch ingress, step-through
Open & Secure Stage Hatch	enter/exit vehicle hatch	hatch ingress, step-through
Open & Secure Stage Hatch	enter/exit vehicle hatch	hatch ingress, step-through
Open & Secure Stage Hatch	enter/exit vehicle hatch	hatch ingress, step-through
Open & Secure Stage Hatch	enter/exit vehicle hatch	hatch ingress, step-through
Open & Secure Stage Hatch	enter/exit vehicle hatch	hatch ingress, step-through
Open & Secure Stage Hatch	enter/exit vehicle hatch	hatch ingress, step-through
Open & Secure Stage Hatch	enter/exit vehicle hatch	hatch ingress, step-through
Open & Secure Stage Hatch	enter/exit vehicle hatch	hatch ingress, step-through

Anthropometric Information:

Please select an attribute:
Arm Length

Arm Length
Measures vertically from the middle fingertip to the acromion landmark on a subject. The subject's arms are straight down at their sides. In Jack, vertically between an acromion site on an upper arm segment and the tip site on a finger 12 segment on the same side.

	NASA Engineering and Safety Center Technical Assessment Report	Document #: NESC-RP-12-00774	Version: 1.0
Title: CAD Tools to Support Human Factors Design Teams		Page #: 100 of 142	



National Aeronautics and Space Administration
Marshall Space Flight Center

[Visit NASA.gov](#)
[Contact Us](#)

Virtual Environments Lab

Home
Data
Search
Subject
Anthro

Postures & Motions Database

NASA Postures and Motions

- Home
- ▶ Data
- Search
- Subject
- Anthro
- ANSUR Database
- Admin

NASA Virtual Environments Lab

This will contain headline news items, and/or important tips to surf the database.

[▶ VEL News ...](#)

BASIC ELEMENT SEARCH

Posture & Motion Keywords:

<input type="checkbox"/> Stand	<input type="checkbox"/> Bend	<input type="checkbox"/> Lift
<input type="checkbox"/> Kneel	<input type="checkbox"/> Reach	<input type="checkbox"/> Lower
<input type="checkbox"/> Squat	<input type="checkbox"/> Twist	<input type="checkbox"/> Transfer
<input type="checkbox"/> Balance	<input type="checkbox"/> Turn	<input type="checkbox"/> Push
<input type="checkbox"/> Step		

Task & Subtask Keywords:

<input type="checkbox"/> Ingress	<input type="checkbox"/> Hatch	<input type="checkbox"/> LRU
<input type="checkbox"/> Egress	<input type="checkbox"/> Door	<input type="checkbox"/> Platform
<input type="checkbox"/> Covers	<input type="checkbox"/> GSE	

Human Operator Characteristics:

<input type="radio"/> 5%	<input type="radio"/> 95%	<input checked="" type="radio"/> All
<input type="radio"/> Male	<input type="radio"/> Female	<input checked="" type="radio"/> All



NASA Engineering and Safety Center Technical Assessment Report

Document #:
**NESC-RP-
12-00774**

Version:
1.0

Title:

CAD Tools to Support Human Factors Design Teams

Page #:
101 of 142

National Aeronautics and Space Administration
Marshall Space Flight Center

Virtual Environments Lab

Home Data Search Subject Anthro

Postures & Motions Database

NASA Postures and Motions

Home
Data
Function
Task
Sub-Task
Element
Search
Subject
Anthro
ANSUR Database
Admin

NASA Virtual Environments Lab
This will contain headline news items, and/or important tips to surf the database.

SUB-TASKS

Function	Task	Sub-Task	Element	Description	Subject	Data
Open & Secure Stage Hatch	enter/exit vehicle hatch	hatch ingress, step-through	stand, step, balance	heel directly over edge during step-in	3	sub-003-hatch-01.zip
Open & Secure Stage Hatch	enter/exit vehicle hatch	hatch ingress, step-through	bend, squat	head directly under edge during step-in	3	sub-003-hatch-01.zip
Open & Secure Stage Hatch	enter/exit vehicle hatch	hatch ingress, step-through	stand, step, balance	hand in open air (need handle), trailing leg lifted	3	sub-003-hatch-01.zip
Open & Secure Stage Hatch	enter/exit vehicle hatch	hatch egress, step-through	stand, step, balance	high point of leg through hatch	3	sub-003-hatch-01.zip
Open & Secure Stage Hatch	enter/exit vehicle hatch	hatch egress, step-through	squat, bend,	centered, both hands behind knees	3	sub-003-hatch-01.zip
Open & Secure Stage Hatch	enter/exit vehicle hatch	hatch egress, step-through	stand, step,	trailing leg just passed through	3	sub-003-

	NASA Engineering and Safety Center Technical Assessment Report	Document #: NESC-RP-12-00774	Version: 1.0
Title: CAD Tools to Support Human Factors Design Teams		Page #: 102 of 142	

Appendix I. Human Research Protocol and Consent Form

National Aeronautics and Space Administration
George C. Marshall Space Flight Center
Marshall Space Flight Center, AL 35812

Human Research Category I Protocol Summary
October 31, 2012

Computer Aided Design Tools to Support Human Factors Design Teams: Primitive Models Database

Principal Investigator: Mariea Dunn Jackson, Ph. D.

The purpose of this project is to develop a library of human model motion and behavior primitives, which are the basic routines or segments used to construct more complex models of postures and motions in the design and analysis of ground processing and maintenance tasks. While these primitives may be useful to aircraft worksite design, their primary utility will be to launch system design by NASA and its contractors and commercial partners. The research will be conducted by the VEL and Human Factors Team at Marshall Space Flight Center, EV74 Systems Analysis Branch.

The project will create a library of ground processing as well as maintenance positions and motions that can be called upon by analysts for any design effort. It will be useful to designers who must decide whether to design a worksite for 1, 2, or more personnel and whether special GSE is required; these and similar decisions directly affect protection of flight hardware and thus, flight safety. This project will reduce the risk of damage to flight hardware by providing human models that accurately represent the way that humans perform ground processing and maintenance tasks. This gives an improved level of reliability to the analyses that evaluate the design for task performance. The library will contain screen shots, video, anthropometric data, and narrative descriptions of performance related observations and suggestions. Reliability (predictive power) of the models in the library as well as constraints will be established. The library will be available for application by NASA and its contractors and commercial partners.

	NASA Engineering and Safety Center Technical Assessment Report	Document #: NESC-RP-12-00774	Version: 1.0
Title: CAD Tools to Support Human Factors Design Teams		Page #: 103 of 142	

National Aeronautics and Space Administration
George C. Marshall Space Flight Center
Huntsville, AL 35812

HUMAN RESEARCH CONSENT FORM

Part 1

TITLE: Computer Aided Design Tools to Support Human Factors Design Teams: Primitive Models Database

A. PURPOSE: The purpose of this project is to develop a library of human model motion and behavior primitives, which are the basic routines or segments used to construct more complex models of postures and motions in the design and analysis of ground processing and maintenance tasks. While these primitives may be useful to aircraft Earth-based worksite design, their primary utility will be to launch system design by NASA and its contractors and commercial partners.

The project will create a library of ground processing as well as maintenance positions and motions that can be called upon by analysts for any design effort. It will be useful to designers who must decide whether to design a worksite for 1, 2, or more personnel and whether special GSE is required; these and similar decisions directly affect protection of the ground crew, flight hardware and thus, flight safety. This project will reduce the risk of damage to flight hardware by providing human models that accurately represent the way that humans perform ground processing and maintenance tasks. This gives an improved level of reliability to the analyses that evaluate the design for task performance. The library will contain images, screen shots, video, anthropometric data, and narrative descriptions of performance related observations and suggestions. Reliability (predictive power) of the models in the library as well as constraints will be established. The library will be available for application by NASA and its contractors and commercial partners.

Your participation in this study will help provide images, video, anthropometric data, and qualitative data for use in the library. This data will be used by analysts for requirements verification and design analysis.

B. INVESTIGATORS:

Principal Investigator: Mariea Dunn Jackson, Ph.D. (MSFC)

C. NATURE OF TESTS OR EXPERIMENT:

Overview

The protocol requires you to perform tasks similar to those that ground crew personnel perform during launch vehicle assembly and maintenance.

	NASA Engineering and Safety Center Technical Assessment Report	Document #: NESC-RP-12-00774	Version: 1.0
Title: CAD Tools to Support Human Factors Design Teams		Page #: 104 of 142	

Typical session

After having read this document and providing your informed consent, we will brief you on the aspects of the session. Next, we will ask you to change into a motion capture suit. You will use a private bathroom with a door lock for this wardrobe change. Once you are in the suit, we will attach markers to the outside of the suit that allow the motion capture system to capture your movements. Next, we will measure your height, arm length, leg length, torso length, and hand length. Next, we may perform a calibration activity in which you stand in the middle of the motion capture grid so that the motion capture system can calibrate its cameras with your starting location.

After the system is calibrated, we will ask you to perform a task. Following are some examples of the tasks and their associated risks. You may be asked to lift a wire frame box with negligible weight. You may be asked to lift a box weighing up to a maximum of 36 pounds. The risks associated with this lifting task are lower back strain, neck strain, knee strain, and arm/wrist strain. You may be asked to reach to a point at, above, or below your standing shoulder height to mate connectors. The risks associated with this task are torso muscle strain, shoulder, elbow, and wrist fatigue. You may be asked to step over an object. The risks associated with this task are trip/fall, loss of balance, and muscle strain in the back, legs, arms, and neck. You may be asked to bend while holding an object weighing up to 36 pounds. The risks associated with these tasks are muscle strain in the torso, trunk, hips, and legs (shank). Attachment 1 describes in more detail the tasks that you may be asked to perform and the risk associated with each.

If you experience any strain, discomfort, or fatigue during the course of the session, you may decline to perform the task or you may end the session, or the investigator, safety officer, or medical monitor (not applicable) may decide to end the session.

Each task will last no more than 3 minutes. You may be asked to repeat a task no more than 5 times. The entire session including wardrobe change, informed consent completion, session explanation, system calibration, and task performance, and changing out of the motion capture suit will last no more than 3 hours. You may take a break whenever you desire, and there will be a mandatory break after 1.5 hours.

You may stop the session at any time and for any reason.

D. MANNER IN WHICH TEST OR EXPERIMENT WILL BE CONDUCTED:

You will be one of up to 30 volunteer participants who will be recruited to come to the Virtual Environments Lab in building 4649 at the Marshall Space Flight Center for this study.

E. DURATION AND LOCATION

	NASA Engineering and Safety Center Technical Assessment Report	Document #: NESC-RP-12-00774	Version: 1.0
Title: CAD Tools to Support Human Factors Design Teams		Page #: 105 of 142	

Your participation is requested over a three-hour period (maximum) during June 2013 through September 2013. The location of the tests will be the Virtual Environments Lab in building 4649 at Marshall Space Flight Center. Excluding travel time to the lab, your total time commitment in this will not exceed 3 hours.

F. FORESEEABLE INCONVENIENCE, DISCOMFORT, AND/OR RISKS:

Back strain: Possible risk that the tasks to be performed, while at safe levels as defined by ergonomic standards and practices for the limited experiment duration, may be considered uncomfortable and may produce temporary fatigue.

Knee strain: Possible risk that the tasks to be performed, while at safe levels as defined by ergonomic standards and practices for the limited experiment duration, may be considered uncomfortable and may produce temporary fatigue.

Arm strain: Possible risk that the tasks to be performed, while at safe levels as defined by ergonomic standards and practices for the limited experiment duration, may be considered uncomfortable and may produce temporary fatigue.

Wrist strain: Possible risk that the tasks to be performed, while at safe levels as defined by ergonomic standards and practices for the limited experiment duration, may be considered uncomfortable and may produce temporary fatigue.

Muscle strain: Possible risk that the tasks to be performed, while at safe levels as defined by ergonomic standards and practices for the limited experiment duration, may be considered uncomfortable and may produce temporary fatigue.

If the participant experiences any strain, discomfort, or fatigue during the course of the session, then the participant, investigator, safety officer, or medical monitor (not applicable) may decide to end the session.

Confidentiality: Although the following efforts will be taken to ensure confidentiality, there remains a remote risk of personal data becoming identifiable. A non-identifying code number will be assigned to the participant's data records, which will be stored in accordance with federal regulatory procedures and accessible only to the investigator. Other than age, gender, and height information, no other identifying individual medical information will be requested. Results from this study will typically be reported in an aggregate statistical format. Any use of individual data to illustrate specific performance features will be labeled in a manner to preserve the participants' anonymity. Any photographs or video of participants involved in the study will not be released without their prior written consent. While all stated precautions would be taken to protect participant anonymity, there is a small risk that some or all data could become identifiable.



NASA Engineering and Safety Center Technical Assessment Report

Document #:
**NESC-RP-
12-00774**

Version:
1.0

Title:

CAD Tools to Support Human Factors Design Teams

Page #:
106 of 142

G. REMUNERATION:

No monetary or other compensation will be provided for volunteering to participate in this research study.

H. RIGHT TO WITHDRAW FROM THE STUDY; HAZARDS ASSOCIATED WITH WITHDRAWAL:

You have the right to withdraw from this study at any time for any reason, although we hope you will not consent to the study unless you intend to complete it.

I. ANSWERS TO QUESTIONS:

You may receive answers to any questions related to this study by making contact with the Principal Investigator, Dr. Mariea Dunn Jackson, at 256.544.2951. Should any problems related to the study occur during its course, please contact the Principal Investigator at that number. You may also call Dr. Ralph Pelligra, MD, Ames Research Center's Chief Medical Officer and Chair of Ames's Human Research Institutional Review Board, office: (650) 604-5163. Dr. Pelligra is your advocate, and you can speak with him confidentially about any concerns and questions relating to this study.

J. REMEDY IN THE EVENT OF INJURY:

In the unlikely event of injury or death, civil servant employees will be compensated according to federal insurance regulations. If you are a contractor or other non-federal employees, you will be covered by Worker's Compensation insurance during the course of your participation in this study. If you sustain an injury caused by this study, the benefits you will receive are those currently provided under the Worker's Compensation law in Alabama. You cannot sue your employer because the law makes Workers' Compensation your only remedy against him/her. You may have other remedies against other persons or organizations, depending on the circumstances or your injury.

I certify that the series of tests for which _____ is to serve as a participant has been explained to him/her in detail.

Date Signature of Participant

Date Signature of Principal Investigator

Date Signature of NASA Medical Monitor (not applicable)

	NASA Engineering and Safety Center Technical Assessment Report	Document #: NESC-RP-12-00774	Version: 1.0
Title: CAD Tools to Support Human Factors Design Teams		Page #: 107 of 142	

PART 2

TO THE SUBJECT: Please read Part I CAREFULLY. Make sure all of your questions have been answered to your satisfaction. Do not sign this form until Part1 has been read by you and signed by the Principal Investigator (P.I.). You will receive a signed copy of the Consent Form.

A. I, _____
(Print Name of Participant HERE)

agree to participate as a subject in this study and experiments described in Part 1 of this form.

B. I am aware of possible foreseeable consequences that may result from participation, and that such participation may otherwise cause me inconvenience or discomfort as described in Part 1.

C. My consent has been freely given. I may withdraw my consent, and thereby withdraw from the study, at any time. I understand (1) that the Principal Investigator may request my withdrawal from the study if I am not conforming to the requirements of the study as outlined in Part 1; (2) that the NASA Medical monitor (not applicable) may request my withdrawal from the study if they feel that my health and well-being are threatened; and (3) that the NASA Facility Safety Manager may terminate the study in the event that unsafe conditions develop that cannot be immediately corrected. I understand that if I withdraw from the study, or am dismissed, I will be paid for the time served up to the point of my departure, but not thereafter.

D. I am not releasing NASA or any other person or organization from liability for any injury arising as a result of this study. I understand that I will receive emergency care if I am injured during the study, but payment for any follow-on care will depend on whether I have some form of applicable insurance, or whether I have made some other arrangements for such follow-on care. I may have other remedies against other persons or organizations, depending upon the circumstances of my injury.

E. I hereby agree that all records collected by NASA in the course of this experiment are available to the NASA Medical Officer (not applicable), Principal Investigator and Co-Investigators and duly authorized research review committee. I grant NASA permission to reproduce and publish all records, notes or data collected from my participation provided that there will be no association by name with the collected data and that confidentiality is maintained unless specifically waived by me. All stated precautions will be taken to protect your anonymity, but there is a small risk that some or all of your data could become identifiable.

F. I understand that I have the right to request the Chair of the Ames Human Research Institutional Review Board (HRIRB) to convene a Board if, at any time, I feel that my rights as a human research subject have been abused or violated.



NASA Engineering and Safety Center Technical Assessment Report

Document #:
**NESC-RP-
12-00774**

Version:
1.0

Title:

CAD Tools to Support Human Factors Design Teams

Page #:
108 of 142

G. I have had an opportunity to ask questions and I have received satisfactory answers to each question I have asked. I understand that the P.I. for the study is the person responsible for this activity and that any pertinent questions will be addressed to her during the course of this study. I have read the above agreement, the attached protocol and/or instructions prior to my signature and understand the contents

Signature of Test Subject Date

Signature of Principal Investigator Date

Printed/Typed Name of Test Subject

Printed/Typed Name of
Principal Investigator

Address

Telephone Number of Principal Investigator

City, State, Zip Code

Subject Signature: Authorization for
Videotaping and Photographing

Telephone Number of Test Subject

Subject Signature: Authorization for
Release of Information to Non-NASA Source(s)



NASA Engineering and Safety Center Technical Assessment Report

Document #:
**NESC-RP-
12-00774**

Version:
1.0

Title:

CAD Tools to Support Human Factors Design Teams

Page #:
109 of 142

Attachment 1

Task Descriptions with Maximum Loads and Possible Risks

Task Descriptions with Maximum Loads and Possible Risks			
Motion - General	Motion - Specific	Max Loads (lbs)	Possible Risks
Leaning			
	Lean unassisted with feet parallel	n/a	Loss of balance-fall; lower back strain; leg strain. <i>Function of load weight, hand distance from lower back, vertical lift region, trunk twisting, postural constraint, grip, floor surface, environmental factors (illumination, temperature, etc.), and personal individual risk factors (health, vision, etc.)</i>
	Lean unassisted with feet not parallel	n/a	Loss of balance-fall; lower torso (back) strain; leg (shank & thigh) strain
	Lean unassisted with feet parallel	n/a	Loss of balance-fall; can affect balance of assistance
	Lean assisted with feet not parallel	n/a	Loss of balance-fall; can affect balance of assistance
Reaching to various directions			
	Reach above shoulder	n/a	Torso muscle strain; shoulder/elbow/wrist joint fatigue; leg strain
	Reach straight ahead	n/a	Torso muscle strain; shoulder/elbow/wrist joint fatigue; leg strain
	Reach to waist	n/a	Torso muscle strain; shoulder/elbow/wrist joint fatigue; leg strain
	Reach to knees	n/a	Torso muscle strain; shoulder/elbow/wrist joint fatigue; leg strain



NASA Engineering and Safety Center Technical Assessment Report

Document #:
**NESC-RP-
12-00774**

Version:
1.0

Title:

CAD Tools to Support Human Factors Design Teams

Page #:
110 of 142

Task Descriptions with Maximum Loads and Possible Risks			
Lifting			
	Lift above shoulder	5	Back Strain; neck strain/fatigue; arm/wrist strain; knee strain
	Lift waist to shoulder	25	Back Strain; neck strain/fatigue; arm/wrist strain; knee strain
	Lift knee to waist	36	Back Strain; neck strain/fatigue; arm/wrist strain; knee strain
	Lift below knees	25	Back Strain; neck strain/fatigue; arm/wrist strain; knee strain
Squatting			
	Squat with hands empty	n/a	Leg shank & thigh fatigue/strain; trunk (back) tension
	Squat while holding object	29	Trunk muscle strain/fatigue; shoulder/elbow/wrist joint fatigue; leg shank & thigh strain; cramping
Bending with feet parallel			
	Bend to various angles	36	Muscle strain in torso-trunk, hips, legs (shank)
	Bend while holding object	36	Muscle strain in torso-trunk, hips, legs (shank), arms, neck
Bending with feet not parallel			
	Bend to various angles	36	Muscle strain in torso-trunk, hips, legs (shank)
	Bend while holding object	36	Muscle strain in torso-trunk, hips, legs (shank), arms, neck
Kneeling			
	Kneel while holding object	30	Muscle strain/cramping in legs (thigh), ankles, torso (back)



NASA Engineering and Safety Center Technical Assessment Report

Document #:
**NESC-RP-
12-00774**

Version:
1.0

Title:

CAD Tools to Support Human Factors Design Teams

Page #:
111 of 142

Task Descriptions with Maximum Loads and Possible Risks			
Lying down			
	Lying on stomach	14	Muscle strain in back, legs, arms, neck
	Lying on back	14	Muscle strain in legs, arms, neck
	Lying on side	14	Muscle strain in back, legs, arms, neck
Installing/removing object			
	Install/remove connector and torque		Torso muscle strain/fatigue; shoulder/elbow/wrist joint fatigue; leg strain
	Install/remove box	30	Torso muscle strain/fatigue; shoulder/elbow/wrist joint fatigue; leg strain
Walking			
	Walk with hands empty	n/a	Assumption - no backpack or attached equipment on person; leg fatigue
	Walk while holding object	36	Torso muscle strain/fatigue; shoulder/elbow/wrist joint fatigue; leg strain
Stepping up, down, and/or over		36	Trip/fall; loss of balance; muscle strain in back, legs, arms, neck
Climbing		n/a	Trip/fall; loss of balance; muscle strain in back, legs, arms, neck
Standing		36	Loss of balance; muscle strain in back, legs, arms, neck
Stooping		31	Loss of balance; muscle strain in back, legs, arms, neck

	NASA Engineering and Safety Center Technical Assessment Report	Document #: NESC-RP-12-00774	Version: 1.0
Title: CAD Tools to Support Human Factors Design Teams		Page #: 112 of 142	

Appendix J. National Institute for Occupational Safety and Health (NIOSH) Lifting Equation Occupational Safety and Health Administration (OSHA)

Recent OSHA polls have shown that back injuries make up as much as 33 to 38 percent of compensable costs in industry today¹. A result of which has been the creation of the General Duty Clause. The General Duty Clause's main purpose is to force employers to provide an environment that is "free from recognized hazards that are causing or are likely to cause serious physical harm¹" to the employees. OSHA created the law in an attempt to reduce the number of injury incidences caused by poor lifting practices. In 1981, the NIOSH created the lifting equation¹. A revised version of this equation stands today as the primary tool used in questionable lifting applications. It represents one of the very few ergonomically measurable analysis tools.

The lifting equation was first published in the NIOSH Work Practices Guide for Manual Lifting in 1981. The equation works by taking into account the major aspects of the lifting and carrying process. It is broken up into two parts, the action limit (AL) and the maximum permissible limit (MPL)¹. Almost every type of worker can achieve the AL whereas the MPL can only be achieved by a few. In terms of the working environment, an object can be lifted by virtually everyone until it reaches the AL. For the weights between the AL and the MPL, specifically trained workers must be applied. Weights that produce values beyond the MPL are not permitted¹.

The AL equation (1) can be found below².

$$AL = (IW)(HF)(VF)(DF)(FF)$$

Where

IW = weight for ideal conditions

HF = distance from the chest the object is held

VF = distance above or below the knuckle height the object is being held

DF = distance the object is being lifted to from origin

FF = Frequency of lifting the part

The MPL is calculated by simply multiplying the AL by 3.

	NASA Engineering and Safety Center Technical Assessment Report	Document #: NESC-RP- 12-00774	Version: 1.0
Title: CAD Tools to Support Human Factors Design Teams		Page #: 113 of 142	

The current standard value for IW stands at 51 pounds¹. This represents the weight that most people could lift given completely ideal conditions. The values of HF, VF, DF, and FF can be found from charts and tables created by the NIOSH. Each of these values equals a number between 0 and 1. When one of these values is less than 1, the IW is reduced by a percentage.

For example, consider applying the lifting equation to a current Monarch Hydraulics process. In the production of the M-3519 hydraulic pump, one of the workers is required to pick up a pump motor off the floor and walk it back to his station. The pumps come on 4×4-foot pallets. The pump pallets are stacked in a manner that puts the pumps at levels ranging from 5-36 inches off the floor. The pumps are arranged on the pallet such that the distance from the midpoint of the worker chest ranges from 5-20 inches. A pump is picked up roughly once every minute and is carried approximately 10 inches above the knuckle level (approximately 40 inches above ground). An 8-hour workday can be assumed. To determine AL and MPL for this process, the dimensions that will give the worst-case scenario should be considered. From the NIOSH charts (Figures 14.15-14.18 and Table 14.7 of *Work Design: Industrial Ergonomics* 3rd ed. by Stephen Knoz) the values are:

$$HF = .3$$

$$VF = .74$$

$$DF = .8$$

$$FF = .94$$

Calculate AL and MPL:

$$AL = (IW)(HF)(VF)(DF)(FF)$$

$$AL = 51\text{lbs}(.3)(.74)(.8)(.94) = 8.51\text{lbs}$$

$$MPL = 3AL = 25.53\text{lbs}$$

These values for AL and MPL indicate that under the conditions stated, almost every type of worker can lift an 8.51lb part. The maximum weight the part can be, assuming a specially assigned worker, is 25.53lbs. For the Monarch application, the part weighs less than 8.51lbs and is within OSHA's guidelines.

This equation used assumes the following [ref 3]:

- Smooth lifts
- Lifting is done without twisting and with two hands

	NASA Engineering and Safety Center Technical Assessment Report	Document #: NESC-RP-12-00774	Version: 1.0
Title: CAD Tools to Support Human Factors Design Teams		Page #: 114 of 142	

- The part being lifted is of moderate width(30 inches or less)
- Unrestricted lifting postures
- Good contacts(handles, shoes on floor)
- Favorable atmosphere
- Maximum ideal weight of 51lbs²

In the Monarch application, several of these assumptions may sometimes be violated. First, the lifting does not always include the use of both hands. It is safe to assume that at times the pumps are picked up with only one hand (because of the smaller size). Good contacts may be lacking because of no handle being present on the pump motor and oily conditions existing within the working environment. Twisting may also be present because of the pump supply being directly behind the workers position. Despite these violations, it can be assumed it is a fairly reasonable result. The violations mentioned would have limited impact on the final estimated weight.

With the use of this analysis tool we have found a way to determine if a current lifting practice can be considered safe. The analysis tool can also be used as an improvement tool for a given process. A company can look at the factors that lower the weight of the Action Limit and try to reduce them. In the case of the Monarch example, the Horizontal Factor should be examined. If a scissors lift table were introduced, the resulting HF value of 1 would increase the AL to nearly 28lbs and the MPL to 85lbs.

To determine if the entire Monarch M-3519 process is OSHA compliant in regards to this lifting equation, the other assembly pieces and the completed pump will need to be analyzed.

NIOSH Equation: [Applications Manual For the Revised NIOSH Lifting Equation](#). U.S. Department of Health and Human Services (DHHS), National Institute of Occupational Safety and Health (NIOSH) Publication No. 94-110, (1994, January 1). Contains a complete description of all terms in the lifting equation with several sample calculations.

	NASA Engineering and Safety Center Technical Assessment Report	Document #: NESC-RP-12-00774	Version: 1.0
Title: CAD Tools to Support Human Factors Design Teams		Page #: 115 of 142	

Revised NIOSH Lifting Equation

The equation is:

$$LC \times HM \times VM \times DM \times AM \times FM \times CM = RWL$$

where LC is the load constant (23 kg) and other factors in the equation are:

- HM, the Horizontal Multiplier factor
- VM, the Vertical Multiplier factor
- DM, the Distance Multiplier factor
- FM, the Frequency Multiplier factor
- AM, the Asymmetric Multiplier factor
- CM, the Coupling Multiplier factor
- RWL, the Recommended Weight Limit

To apply the NIOSH equation to a situation of interest:

- For each value, look up the corresponding factor and use this number in the equation. See [Assessing Relevant Handling Factors](#) for explanation of terms.
- To use the calculator, click on the values for each factor in the left hand column (or you can input your numbers directly into the second equation). Press the "Calculate RWL" button when you have finished selecting all of the values.
- HM: Horizontal distance (H, in cm) from the midpoint between the ankles to the hands while holding the object.

H = Horizontal Distance (cm)	HM Factor
25 or less	1.00
30	0.83
40	0.63
50	0.50
60	0.42

	NASA Engineering and Safety Center Technical Assessment Report	Document #: NESC-RP- 12-00774	Version: 1.0
		Title: CAD Tools to Support Human Factors Design Teams	

Appendix K. Phase 2 Quick Look Test Reports

Motion Capture Analysis Phase 2 Quick Look Test Reports¹

PHASE 2 MOTION CAPTURE SESSION 1

July 23, 2013

Location: MSFC Bldg. 4649; Virtual Environments Laboratory (VEL)

Personnel: Jason Quick; Trey Perry; Marlin Williamson; Test Subject (S) # 001*

Observers: Jill Brown; Jack Stokes

Task: Data Collection for 95th percentile male Test Subject (S) in VEL Motion Capture Simulator

Session Plan:

- Conduct Phase 2 subtask data collection simulations utilizing 95th percentile 1988 ANSUR measured male subject and low-fidelity wire frame and solid hatch and Line Replaceable Unit (LRU) mockups.
- Obtain element data for A) installation/removal of wireframe hatch; B) installation/removal of solid weighted hatch; and C) Installation of protective devices on vehicle interior protrusions, requiring physical bending and twisting.
- Understanding that S's are not qualified KSC ground technicians, collect subjective anecdotal information and opinions from test subject as support to recorded simulation data.
- Notes on Subject Feedback form (used during session). The form asks to rate tasks on scale from 1-5, with 5 being most difficult, then to describe which posture/motion S found most difficult, finalizing with S general comments.

Session Results:

A. Wireframe part-task mockup with wireframe hatch positioned on simulated GSE support stand: Trial 1: T-Pose, Removal of hatch from GSE stand, transfer of hatch to wireframe mockup of simulated Stage vehicle, position hatch in vehicle opening, then T-Pose; Trial 2: T-Pose, Remove hatch from vehicle, transfer hatch to GSE, install hatch on GSE stand, T-Pose; and Trial 3: Initiate with T-Pose, replicate previous operations without a break, and finish with T-Pose.

¹ Reports due 3 working days after test.

	NASA Engineering and Safety Center Technical Assessment Report	Document #: NESC-RP-12-00774	Version: 1.0
Title: CAD Tools to Support Human Factors Design Teams		Page #: 117 of 142	

B. Hatch outfitted with 25 lb. weight to create handling challenges. Motion procedure included, Trial 1: initiated with T-Pose; removal of hatch from GSE stand, transferring hatch to simulated vehicle, positioned hatch in vehicle opening, then T-Pose; Trial 2: T-Pose, Remove hatch from vehicle, transfer weighted hatch to GSE, install hatch on GSE stand, T-Pose; and Trial 3: Initiate with T-Pose, replicate previous operations without a break, and finish with T-Pose.

C. Solid part-task mockup with hatch and protrusion protective devices: Hatch removed, protective covers installed on internal vehicle extrusions: Motion procedure included, Trial 1: T-Pose, Receive protective devices from GSE and position in front of hatch, Stabilized, reach into stage through hatch and twist to install protective covers, step back, T-Pose.

Notes from research facilitator's Subject Feedback form (used during session). *The form asks to rate tasks on scale from 1-5, 5 being most difficult, then which posture/motion did they find most difficult, then general comments at the end.*

Notable Observations, Lessons Learned, and Actions:

- Phase 1 mockup setup: Mockup tipped by subject (S) pushing mockup during protrusion cover installation tasks (required reaching in open hatch). Correction: S permitted to stabilize on mockup stage wall around opening.
- Stage hatch part-task mockup requires improved stabilization to prohibit moving it by S. Jack also commented to S that dropping battery too hard into the holder was ill-advised because it was expensive hardware. The root of those actions seemed to be the finger pinch hazard between the box flange and the box holder. Should have finger cutouts added to holder.

Next Session Plan:

- Assess hatches, LRU access, interior protrusion fastening.

* **NOTE:** Test Subject identification numbers herein are temporarily assigned and will be adjusted to align with Phase One test results and documentation.

	NASA Engineering and Safety Center Technical Assessment Report	Document #: NESC-RP-12-00774	Version: 1.0
Title: CAD Tools to Support Human Factors Design Teams		Page #: 118 of 142	

PHASE 2 MOTION CAPTURE SESSION 2

July 31, 2013

Personnel: Jason Quick; Trey Perry; Marlin Williamson; Test Subject (S) # 002* (95th percentile male)

Task: Data Collection for 95th percentile Male Test Subject (S) in VEL Motion Capture Simulator

Location: MSFC Bldg. 4649; Virtual Environments Laboratory (VEL)

Personnel: Trey Perry; Marlin Williamson; Test Subject # 002*

Task: Data Collection for 95th percentile Male Test Subject (S) in VEL Motion Capture

Session Plan:

- Conduct Phase 2 subtask data collection simulations utilizing 95th percentile 1988 ANSUR measured male subject and low-fidelity wire frame and solid hatch and Line Replaceable Unit (LRU) mockups.
- Obtain element data for A) installation/removal of wireframe hatch; B) installation/removal of solid weighted hatch; C) Positioning of LRU in overhead location; and D) Installation and removal of protrusion devices on vehicle interior.
- Understanding that S's are not qualified KSC ground technicians, collect subjective anecdotal information and opinions from test subject as support to recorded simulation data.
- Test data provided from notes on Subject (S) performance and feedback form (used during session). The form asked to rate tasks on scale from 1-5, with 5 being most difficult, then to describe which posture/motion S found most difficult, finalizing with S general comments.

Session Results:

A. Wireframe Hatch Installation/Removal: Wireframe Hatch placed into and removed from wireframe part-task mockup of stage wall. Motion procedure included, Trial 1: initiated with T-Pose, then removal of hatch from the simulated stage wall, placing it on the simulated GSE stand, then return to T-Pose; Trial 2: T-Pose, Remove hatch from GSE stand, transfer hatch

	NASA Engineering and Safety Center Technical Assessment Report	Document #: NESC-RP-12-00774	Version: 1.0
Title: CAD Tools to Support Human Factors Design Teams		Page #: 119 of 142	

to mounting location in simulated stage wall, T-Pose; Trial 3: Trial 5: Initiate with T-Pose, replicate previous operations without a break, and finish with T-Pose.

B. Solid Mass Similar Hatch Installation/Removal: Hatch outfitted with 25 lb. weight to create handling challenges. Motion procedure included, Trial 1: initiated with T-Pose removal of hatch from GSE stand, transferring hatch to simulated vehicle, positioned hatch in vehicle opening, then T-Pose; Trial 2: T-Pose, Remove hatch from vehicle, transfer weighted hatch to GSE, install hatch on GSE stand, T-Pose; and Trial 3: Initiate with T-Pose, replicate previous operations without a break, and finish with T-Pose.

C. Overhead Battery Installation/Removal: Motion procedure included, Trial 1: initiated with T-Pose, remove battery mass mockup from GSE stand, transfer to and position at simulated overhead mounting position, transfer to and position at simulated floor mounting position, transfer to and position on GSE stand, then T-Pose;

D. Overhead Fastening Task: Using Allen wrench tool operate fasteners in “Moseman Puck” as bracketry within stage interior volume. Motion procedure included, Trial 1: initiated with T-Pose, reach to puck, insert tool into fastener head, and twist, T-Pose; Trial 2: Replicate task at location #2, T-Pose; Trial 3: Replicate task at location #3, T-Pose.

Notable Observations, Lessons Learned, and Actions:

- This was only a partial test session. Utilized new wireframe mockups with plywood supports. Some technical and procedural adjustments were required; mockup adjustments and video and operational procedures extended session length. Included a mix of wireframe receiver and weighted wooden box for new overhead motions. Added “complex connection” tasks against the wall, utilizing a tool to tighten a “Moseman Puck” fastener at 3 locations: low, middle and overhead elevations (may be an issue with 5th percentile females).
- Some data lost because of loss of elbow marker, without realizing it was missing.
- Majority of comments concerned the detail/precision needed for holding & fastening overhead LRU actions—provided excellent insight (current SLS design of equipment shelf around the engine apparently may not have a captive system for holding LRUs in place before tightening fasteners...this is a major HFE and operations concern!)
- Tightening fasteners required S pausing to study a method for connector mating; offers natural postures for database library because of the focus needed on the task.

Next Session Plan: Use 5th percentile S for hatch installation/removal and LRU handling.

* **NOTE**: Test Subject identification numbers herein are temporarily assigned and will be adjusted to align with Phase One test results and documentation.

	NASA Engineering and Safety Center Technical Assessment Report	Document #: NESC-RP-12-00774	Version: 1.0
Title: CAD Tools to Support Human Factors Design Teams		Page #: 120 of 142	

PHASE 2 MOTION CAPTURE SESSION 3
August 1, 2013

Location: MSFC Bldg. 4649; Virtual Environments Laboratory (VEL)

Personnel: Jason Quick; Trey Perry; Marlin Williamson; Test Subject (S) # 004*(5th percentile female)

Task: Data Collection for 5th percentile Female Test Subject (S) in VEL Motion Capture Simulator

Session Plan:

- Conduct Phase 2 subtask data collection simulations utilizing 5th percentile 1988 ANSUR measured female subject and low-fidelity wire frame and solid hatch and Line Replaceable Unit (LRU) mockups.
- Collect data for A) installation/removal of wireframe hatch; B) installation/removal of solid weighted hatch; C) installation/removal of wireframe LRU through hatch opening; D) installation/removal of wireframe LRU mockup through hatch opening; E) positioning LRU mass mockup in overhead mounting location; F) mate/demate of connectors through 8 inch access port part-task mockup, and G) subject ingress/egress through hatch.
- Understanding that S's are not qualified KSC ground technicians, collect subjective anecdotal information and opinions from test subject as support to recorded simulation data.

Session Results:

A. Wireframe Hatch Installation/Removal: Wireframe Hatch placed into and removed from hatch opening of wireframe part-task mockup of stage wall. Motion procedure included, Trial 1: initiated with T-Pose, then removal of Wireframe Hatch from the simulated GSE stand, placing it on the hatch opening of the simulated stage wall, then return to T-Pose; Trial 2: T-Pose, Remove hatch from simulated stage wall, transfer hatch to mounting location on GSE stand, T-Pose; Trial 3: Initiate with T-Pose, replicate previous operations without a break, and finish with T-Pose.

B. Weighted Hatch Installation/Removal: Weighted Hatch placed into and removed from hatch opening of solid part-task mockup of stage wall. Motion procedure included, Trial 1: initiated with T-Pose, then removal of solid hatch from the simulated GSE stand, placing it on the hatch opening of the simulated stage wall mockup, then return to T-Pose; Trial 2: T-Pose, Remove hatch from simulated stage wall,

	NASA Engineering and Safety Center Technical Assessment Report	Document #: NESC-RP-12-00774	Version: 1.0
Title: CAD Tools to Support Human Factors Design Teams		Page #: 121 of 142	

transfer hatch to mounting location on GSE stand, T-Pose; Trial 3: Initiate with T-Pose, replicate previous operations without a break, and finish with T-Pose.

C. Wireframe LRU Pass-through: Motion procedure included, Trial 1: initiated with T-Pose, remove LRU wireframe mockup from GSE stand, transfer to and position on simulated “diving board” GSE platform, transfer to and position at simulated floor mounting position, transfer to and position on GSE stand, then T-Pose;

D. Overhead LRU Installation/Removal: Motion procedure included, Trial 1: initiated with T-Pose, wireframe LRU mockup from GSE stand, transfer to and position at wireframe hatch opening, position at simulated overhead mounting position, transfer to and position at simulated floor mounting position, transfer to and position on GSE stand, then T-Pose;

E. Overhead Fastening Task: Using Allen wrench tool operate fasteners in “Moseman Puck” as bracketry within stage interior volume. Motion procedure included, Trial 1: initiated with T-Pose, reach to puck, insert tool into fastener head, and twist, T-Pose; Trial 2: Replicate task at location #2, T-Pose; Trial 3: Replicate task at location #3, T-Pose.

F. Connector mate through access port: Mate electrical connectors through 8 inch access port: Motion procedure included: Trial 1: T-Pose, Pass three connectors individually through access port and connect to mating female connector mounted on connector plate, T-Pose.

Notable Observations, Lessons Learned, and Actions:

- Achieved most of desired captures, will have second session.
- Two sessions conducted on this day, morning had T-Pose calculations, afternoon collected element data.

Next Session Plan:

Use 95th percentile S for hatch access

* **NOTE:** Test Subject identification numbers herein are temporarily assigned and will be adjusted to align with Phase One test results and documentation.

	NASA Engineering and Safety Center Technical Assessment Report	Document #: NESC-RP-12-00774	Version: 1.0
Title: CAD Tools to Support Human Factors Design Teams		Page #: 122 of 142	

PHASE 2 MOTION CAPTURE SESSION 4

August 5, 2013

Location: MSFC Bldg. 4649; Virtual Environments Laboratory (VEL)

Personnel: Jason Quick; Trey Perry; Marlin Williamson; Test Subject (S) # 001* (95th percentile male)

Task: Data Collection for 95th percentile Male Test Subject (S) in VEL Motion Capture Simulator



Session Plan:

- Conduct Phase 2 subtask data collection simulations utilizing 95th percentile 1988 ANSUR measured male subject and low-fidelity wire frame and solid hatch and Line Replaceable Unit (LRU) mockups.
- Redo collection for wireframe hatch installation/ removal, because of previous lost data.
- Collect data for: A) wireframe hatch installation/ removal; B) Interior attachment bracket ("Moseman Puck") operation with Allen wrench at 9 vertical locations; C) fastening wireframe LRU to interior brackets (Moseman Puck) at 5 locations; D) position wireframe LRU at upper and lower locations in simulated stage vehicle interior; E) position weighted battery LRU mass mockup LRU at upper and lower locations in simulated stage vehicle interior; F) subject egress/ingress through solid hatch opening; and G) (Wireframe hatch) squatting & reaching forward (this was a MOCAP constraint) — NOTE: VEL operator asked S to stand back from boundary of capture volume.
- Completion of anthropometric measures of S.

	NASA Engineering and Safety Center Technical Assessment Report	Document #: NESC-RP-12-00774	Version: 1.0
Title: CAD Tools to Support Human Factors Design Teams		Page #: 123 of 142	

Session Results:

- A. Hatch Installation/Removal: Wireframe hatch with wireframe part-task mockup, hatch positioned on simulated GSE support stand; Motion procedure included, Trial 1: T-Pose, Removal of hatch from GSE stand, transfer of hatch to wireframe mockup of simulated Stage vehicle, position hatch in vehicle opening, then T-Pose; Trial 2: T-Pose, Remove hatch from vehicle, transfer hatch to GSE, install hatch on GSE stand, T-Pose; and Trial 3: Initiate with T-Pose, replicate previous operations without a break, and finish with T-Pose.
- B. Stage Interior Fastening Task: Using Allen wrench tool operate fasteners in “Moseman Puck” representing mounting bracketry within stage interior volume at 9 locations. Motion procedure included, Trial 1: initiated with T-Pose, reach to Puck #1 (lower), insert tool into fastener head, and twist screw, T-Pose; Trial 2-9: Replicate task at Pucks #2 - #9, T-Pose; NOTE: Bracket #4 task aborted, because of S reach difficulties.
- C. LRU Mounting: Fasten Wireframe LRU at 5 locations on interior wall: Motion procedure included, Trial 1: initiated with T-Pose, reach to Puck #1 (lower), insert tool into fastener head, and twist screw, T-Pose; Trial 2-5: Replicate task at Puck #2- #5, T-Pose.
- D. Wireframe LRU interior mounting: Motion procedure included, Trial 1: T-Pose, Transfer wireframe LRU from hatch (“diving board”) to location overhead and position, T-Pose; Trial 2: T-Pose, Transfer wireframe LRU from location overhead to location at feet (floor) and position, T-Pose; Trial 3: T-Pose, Transfer wireframe LRU from location on floor to location overhead and position, T-Pose; Trial 4: T-Pose, Transfer wireframe LRU from location overhead to GSE Stand and position, T-Pose; Trial 5: Initiate with T-Pose, replicate previous operations without a break, and finish with T-Pose.
- E. Weighted battery LRU interior mounting: Motion procedure included, Trial 1: T-Pose, Transfer wireframe LRU from hatch (“diving board”) to location overhead and position, T-Pose; Trial 2: T-Pose, Transfer weighted LRU from location overhead to location at feet (floor) and position, T-Pose; Trial 3: T-Pose, Transfer weighted LRU from location on floor to location overhead and position, T-Pose; Trial 4: T-Pose, Transfer weighted LRU from location overhead to GSE Stand and position, T-Pose; Trial 5: Initiate with T-Pose, replicate previous operations without a break, and finish with T-Pose.
- F. Egress/ingress (3/5) – bending over and not hitting head when centerline in/line [passing thru] hatch

	NASA Engineering and Safety Center Technical Assessment Report	Document #: NESC-RP-12-00774	Version: 1.0
Title: CAD Tools to Support Human Factors Design Teams		Page #: 124 of 142	

G. Tenuous body geometry at hatch: Motion procedure included, Trial 1: T-Pose, squat, reach forward with arms, T-Pose.

NOTE: Wireframe LRU overhead (Location 4/5) – getting wireframe to line up with capture hooks; margin of error, precise task. LRU overhead (5/5) – holding weight overhead; strain, high “potential energy” at highest elevation, holding as still as possible overhead recognized as precision in positioning

Notable Observations, Lessons Learned, and Actions:

- Subject: minimal Ground Ops knowledge, considered being tall might affect ability to perform tasks; wore glasses during session: time of sessions was potential concern; excited to help w/ motion capture and be on screen in JACK
- Need to add platform edge (toe kick) beneath LVSA wire hatch to simulate separation between vehicle wall and gantry edge; great task order list for team communication during sessions.
- Note: Session C (LRU @ location 5) – with LRU above the head; harder to have fine control [dexterity] overhead. Observed by researcher (OBS): needed to hold the wall/attach location for balance during squatting.

Next Session Plan: Motions with mass mockups and connector access.

* **NOTE:** Test Subject identification numbers herein are temporarily assigned and will be adjusted to align with Phase One test results and documentation.

	NASA Engineering and Safety Center Technical Assessment Report	Document #: NESC-RP-12-00774	Version: 1.0
Title: CAD Tools to Support Human Factors Design Teams		Page #: 125 of 142	

PHASE 2 MOTION CAPTURE SESSION 5

August 6, 2013

Location: MSFC Bldg. 4649; Virtual Environments Laboratory (VEL)

Personnel: Jason Quick; Trey Perry; Marlin Williamson; Test Subject (S) # 002* (95th percentile male)

Task: Data Collection for 95th percentile Male Test Subject (S) in VEL Motion Capture Simulator

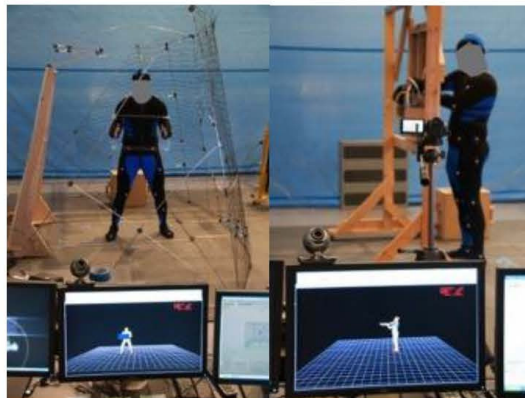

Session Plan:

- Conduct Phase 2 subtask data collection simulations utilizing 95th percentile 1988 ANSUR measured male subject and low-fidelity wire frame and solid hatch and Line Replaceable Unit (LRU) mockups.
- Collect data for: A) Transfer battery LRU mass mockup from stand and return; B) Locate wireframe LRU inside vehicle interior; C) Subject ingress/egress through hatch opening; D) Transfer hatch mass mockup from stand and return; E) Operate electrical connectors through access port
- Understanding that S's are not qualified KSC ground technicians, collect subjective anecdotal information and opinions from test subject as support to recorded simulation data.

Session Results:

- A. LRU Transfer: Weighted LRU mass mockup transfer from GSE stand to hatch opening and return; Motion procedure included, Trial 1: T-Pose, Removal of LRU mass mockup from GSE stand, transfer of LRU to wooden part-task mockup, position LRU through hatch

	NASA Engineering and Safety Center Technical Assessment Report	Document #: NESC-RP-12-00774	Version: 1.0
Title: CAD Tools to Support Human Factors Design Teams		Page #: 126 of 142	

opening on “diving board” horizontal GSE surface, then T-Pose; Trial 2: T-Pose, Remove LRU from diving board at hatch opening, transfer LRU to GSE, install LRU on GSE stand, T-Pose; and Trial 3: Initiate with T-Pose, replicate previous operations without a break, and finish with T-Pose.

- B. Locate wireframe LRU mockup in various mounting positions. Motion procedure included, Trial 1: T-Pose, Transfer wireframe LRU from hatch (“diving board”) to location overhead and position, T-Pose; Trial 2: T-Pose, Transfer wireframe LRU from location overhead to location at feet (floor) and position, T-Pose; Trial 3: T-Pose, Transfer wireframe LRU from location on floor to location overhead and position, T-Pose; Trial 4: T-Pose, Transfer wireframe LRU from location overhead to GSE Stand and position, T-Pose; Trial 5: Initiate with T-Pose, replicate previous operations without a break, and finish with T-Pose.
- C. Subject ingress/egress through slid hatch opening: Motion procedure included, Trial 1: T-Pose, Step through hatch opening of solid mockup, then T-Pose; Trial 2: T-Pose, Step through hatch opening of solid mockup, then T-Pose
- D. Transfer hatch mass mockup from GSE stand, install, and return it to GSE stand: Motion procedure included, Trial 1: T-Pose, Step through hatch opening of solid mockup, then T-Pose; Trial 2: T-Pose, Remove hatch from hatch opening, transfer hatch to GSE, install hatch on GSE stand, T-Pose; and Trial 3: Initiate with T-Pose, replicate previous operations without a break, and finish with T-Pose.
- E. Mate electrical connectors through 8 inch access port: Motion procedure included: Trial 1: T-Pose, Pass three connectors individually through access port and connect to mating female connector mounted on connector plate, T-Pose.

Notable Observations, Lessons Learned, and Actions:

- Markers added to LRU mass mockup with flange and recaptured shelf-to-box, box-to-overhead. Also markers were added to weighted hatch and recaptured. Informally tested markers.
- Introduced the MSA electrical connection and 8 inch access port mockup – acceptable motion capture data even with obstructions from solid surfaces.
- Interior connector cable loose wires on back of access port mockup should be restrained above the access port to increase realism of motions. For this test session, S manipulated connector and loose tail reaching through the access port.
- The most [perceived] technical complex task was lifting weighted LRU mass mockup AND having to simultaneously deal with integrated fasteners (note: this was only an envisioned scenario that the S brought up, we only asked them to hold in place overhead). This highlighted the need for a restrained LRU prior to addressing fasteners. Heaviest lifting task was extending/retrieving the LRU box thru hatch.

	NASA Engineering and Safety Center Technical Assessment Report	Document #: NESC-RP- 12-00774	Version: 1.0
Title: CAD Tools to Support Human Factors Design Teams		Page #: 127 of 142	

- Collection of subjective anecdotal information and opinions from test subject as support to recorded simulation data.

Next Session Plan: Additional hatch, LRU, and connector captures.

* **NOTE:** Test Subject identification numbers herein are temporarily assigned and will be adjusted to align with Phase One test results and documentation.



NASA Engineering and Safety Center Technical Assessment Report

Document #:
**NESC-RP-
12-00774**

Version:
1.0

Title:

CAD Tools to Support Human Factors Design Teams

Page #:
128 of 142

PHASE 2 MOTION CAPTURE SESSION 6

August 9, 2013

Location: MSFC Bldg 4649; Virtual Environments Laboratory (VEL)

Personnel: Jason Quick; Trey Perry; Marlin Williamson; Jack Stokes; Test Subject (S) # 004*

Task: Data Collection for 5th percentile Female Test Subject (S) in VEL Motion Capture Simulator





**NASA Engineering and Safety Center
Technical Assessment Report**

Document #:
**NESC-RP-
12-00774**

Version:
1.0

Title:

CAD Tools to Support Human Factors Design Teams

Page #:
129 of 142

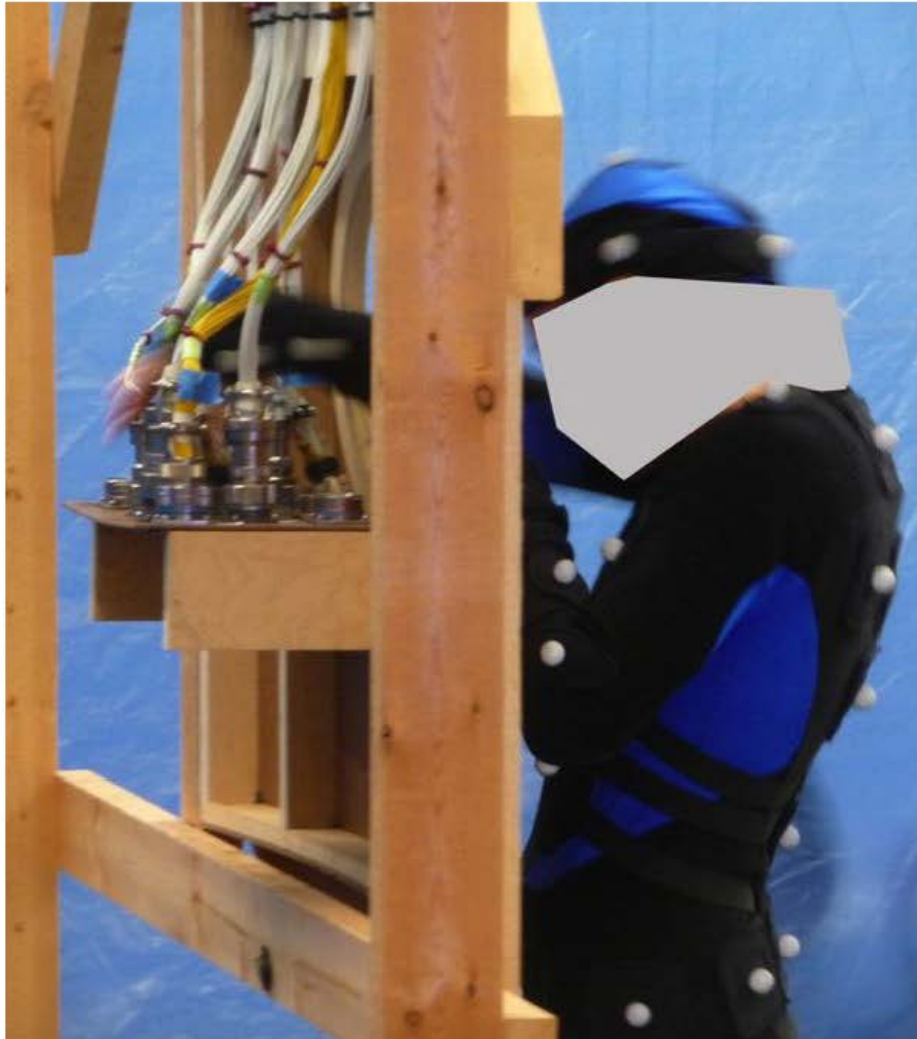

	NASA Engineering and Safety Center Technical Assessment Report	Document #: NESC-RP-12-00774	Version: 1.0
Title: CAD Tools to Support Human Factors Design Teams		Page #: 130 of 142	

Session Plan:

- Conduct Phase 2 subtask data collection simulations utilizing 5th percentile 1988 ANSUR measured female subject and low-fidelity wire frame and solid hatch and Line Replaceable Unit (LRU) mockups.
- Fine-tune data collection nuances with 5th percentile 1988 ANSUR measured female test subject, including A) installation/removal of hatch; B) 1-G Line Retrieval Unit (LRU) transfer; C) LRU located overhead; and D) multiple connector mate/demate in part-task mockups.
- Minor adjustments to data collection software.
- Understanding that S's are not qualified KSC ground technicians, collect subjective anecdotal information and opinions from test subject as support to recorded simulation data.

Session Results:

- A. Hatch Installation/Removal: Hatch outfitted with 25 lb. weight to create handling challenges. Motion procedure included, Trial 1: initiated with T-Pose removal of hatch from GSE stand, transferring hatch to simulated vehicle, positioned hatch in vehicle opening, then T-Pose; Trial 2: T-Pose, Remove hatch from vehicle, transfer weighted hatch to GSE, install hatch on GSE stand, T-Pose; and Trial 3: Initiate with T-Pose, replicate previous operations without a break, and finish with T-Pose.
- B. LRU Transfer: Weighted LRU mockup located on simulated GSE stand and moved “into” vehicle interior for LRU installation/removal. Motion procedure included: Trial 1: T-Pose, Transfer weighted LRU mockup from GSE shelf to vehicle installation frame, T-Pose; Trial 2: T-Pose, Transfer LRU from vehicle installation frame to GSE shelf, T-Pose; Trial 3: Initiate with T-Pose, replicate previous operations without a break, and finish with T-Pose.
- C. LRU Overhead and Floor-level Access: Weighted LRU mockup located on interim location “inside” simulated launch vehicle and relocated to overhead mounting location, then to floor location: Motion procedure included: Trial 1: T-Pose, Access weighted LRU mockup from vehicle waist-high “interior shelf” to vehicle overhead installation frame, hold above, relocated LRU to floor level resting location, T-Pose; Trial 2: T-Pose, Reverse of previous steps,” T-Pose; Trial 3: replicate transferring LRU from shelf to overhead positions and reversal, and finish with T-Pose.
- D. Electronic Cable Connector Mate/Demate: Utilizing Ares/SLS access hatch, 10 flight-like connectors were mated via restricted access and fixed floor height. Motion procedure included: Trial 1: T-Pose, Mate free-dangling connectors to connector plate beginning with back connectors and working forward, T-Pose.

	NASA Engineering and Safety Center Technical Assessment Report	Document #: NESC-RP-12-00774	Version: 1.0
Title: CAD Tools to Support Human Factors Design Teams		Page #: 131 of 142	

Notable Observations, Lessons Learned, and Actions:

- 5th percentile subject was required to stretch to tiptoes to place weighted LRU above head into receiver. A platform would have made the task much simpler and safer.
- Subject had difficulties reaching over mated connectors/cables to access farthest connectors for demate/re-mate. Subject had difficulty mating and locking connectors at the back of connector plate. NOTE: Connector spacing is per NASA-STD-3000/3001 for ground access.
- Subject slightly violated (mockup) spacing between access gantry and launch vehicle wall, providing a bit more access than would exist in a real world environment.

Next Session Plan:

- Another 5th percentile subject simulation will be conducted to build on the data prior to loading the database. Record still shot photos as examples of possible simulation element postures. A request for naïve test S's will be placed in the Marshall Star, constraining S's to only civil servants whose supervisors are in agreement with their participation and approximate the 5th and 95th percentile population.

* **NOTE:** Test Subject identification numbers herein are temporarily assigned and will be adjusted to align with Phase One test results and documentation.

	NASA Engineering and Safety Center Technical Assessment Report	Document #: NESC-RP-12-00774	Version: 1.0
Title: CAD Tools to Support Human Factors Design Teams		Page #: 132 of 142	

PHASE 2 MOTION CAPTURE SESSION 7

August 14, 2013

Location: MSFC Bldg. 4649; Virtual Environments Laboratory (VEL)

Personnel: Trey Perry; Marlin Williamson; Jack Stokes; Test Subject (S) # 005*

Task: Data Collection for 95th percentile Male Test Subject (S) in VEL Motion Capture Simulator

Session Plan:

- Conduct Phase 2 subtask data collection simulations utilizing 95th percentile 1988 ANSUR measured male subject and low-fidelity wire frame and solid hatch and Line Replaceable Unit (LRU) mockups.
- Fine-tune data collection nuances including A) installation/removal of wireframe hatch; B) 1-G Line Retrievable Unit (LRU) transfer on “diving board” horizontal GSE platform; and C) multiple connector mate/demate in part-task mockup.
- Verify 1988 ANSUR measurements are correct for database.
- Understanding that S’s are not qualified KSC ground technicians, collect subjective anecdotal information and opinions from test subject as support to recorded simulation data.

Session Results:

A. **Hatch Installation/Removal:** Wireframe Hatch placed into and removed from wireframe part-task mockup of stage wall. Motion procedure included, Trial 1: initiated with T-Pose, then removal of hatch from the simulated stage wall, placing it on the simulated GSE stand, then return to T-Pose; Trial 2: T-Pose, Remove hatch from GSE stand, transfer hatch to mounting location in simulated stage wall, T-Pose; Trial 3: Trial 5: Initiate with T-Pose, replicate previous operations without a break, and finish with T-Pose.

B. **LRU Transfer:** Weighted LRU low fidelity/simulated mass battery mockup located on simulated GSE stand and moved to simulated “diving board” platform at vehicle hatch entrance for LRU translation into stage. Motion procedure included: Trial 1: T-Pose, Transfer weighted LRU mockup from GSE shelf to vehicle installation frame, T-Pose; Trial 2: T-Pose, Transfer LRU from platform to GSE shelf, T-Pose; Trial 3: T-Pose, Transfer weighted LRU mockup along the “diving board” platform into vehicle Interior; Trial 4: T-Pose, replicate previous operations without a break, and finish with T-Pose.

	NASA Engineering and Safety Center Technical Assessment Report	Document #: NESC-RP-12-00774	Version: 1.0
Title: CAD Tools to Support Human Factors Design Teams		Page #: 133 of 142	

C. Electronic Cable Connector Mate/Demate: Utilizing Ares/SLS access hatch mockup, three connectors on the backside of a plate of 11 flight-like connectors were mated and demated via restricted access and fixed floor height. An additional run utilized a raised platform (~6 inch high) on which the S stood. Motion procedure included: Trial 1: T-Pose, Demate three connectors on connector plate beginning with back connectors and working forward, T-Pose. Trial 2: T-Pose, Mate three connectors on backside of connector plate, T-Pose. Trial 3: T-Pose, Repeat previous motions with S standing on raised platform, T-Pose.

D. 1988 ANSUR Data Measurements: Anthropomorphic data measurements were collected on the subject to validate existing data and to collect additional key measurement deemed as necessary.

Notable Observations, Lessons Learned, and Actions:

- 95th percentile subject was not seriously challenged in reaching or observing connectors. The raised platform, provided as assistance for the 5th percentile female did not hinder operation for the 95th percentile male. Subject stumbled on platform when stepping upon it. There was significant friction between the subject's posterior and the anti-skid surface of the 6 inch platform. S recommended using corrugated flooring (diamond plate) versus flat non-skid surface
- Subject had difficulties reaching over mated connectors/cables to access the three farthest connectors for demate/re-mate. Subject had difficulty mating and locking connectors at the back of connector plate. NOTE: Connector spacing is similar to NASA-STD-3000/3001 for ground access. Part of issue was mockup fidelity, as connector plate flexed when 95th percentiles subject attempted to initiate connection (*repair was completed prior to test end*). Part of issue was the fact that the female connector keys, normally positioned for visual access were not so positioned in the mockup, thereby prohibiting visual alignment cues.
- Though connector alignment issues were identified, the S did provide some recorded elements, which might later be useful in building a special library of assembly and maintenance difficulties or challenges, or contingency operations.
- Subject was an experienced technical expert familiar with mass properties of LRUs, hence he adjusted postures and motions as if the wire frame had a flight-like mass about it. However, he did not realize mockup was imposed a realistic mass (weight). It is recommended that in future test runs, the subjects pick up the mockups for familiarization prior to test initiation.
- Mockup issues: 1) flexibility in wire-frame stage wall around hatch – gravity partially flattens curvature; needs reinforcement to hold curvature; 2) Simulated GSE platform does not have adequate surface to support open face of wire frame box; enlarge support face; 3) Align connectors on connector plate so that alignment keys are visible to operator (it would be good to use alignment markings on connector shells). Verify connector spacing is per NASA HFE standards for ground assembly.

	NASA Engineering and Safety Center Technical Assessment Report	Document #: NESC-RP- 12-00774	Version: 1.0
Title: CAD Tools to Support Human Factors Design Teams		Page #: 134 of 142	

Next Session Plan:

- Another 95th percentile subject simulation will next be conducted to build on the data prior to loading the database. Element data collection will be performed similar to that collected in the current run.

* **NOTE:** Test Subject identification numbers herein are temporarily assigned and will be adjusted to align with Phase One test results and documentation.

	NASA Engineering and Safety Center Technical Assessment Report	Document #: NESC-RP-12-00774	Version: 1.0
Title: CAD Tools to Support Human Factors Design Teams		Page #: 135 of 142	

PHASE 2 MOTION CAPTURE SESSION 8

August 15, 2013

Location: MSFC Bldg. 4649; Virtual Environments Laboratory (VEL)

Personnel: Trey Perry; Marlin Williamson; Jack Stokes; Test Subject (S) # 004*

Task: Data Collection for 5th percentile Female Test Subject (S) in VEL Motion Capture Simulator

Session Plan:

- Conduct Phase 2 subtask data collection simulations utilizing 5th percentile 1988 ANSUR measured female subject and low-fidelity wire frame and solid hatch and Line Replaceable Unit (LRU) mockups.
- Fine-tune data collection nuances including A) installation/removal of simulated “diving board” horizontal GSE platform; B) 1-G Line Retrievable Unit (LRU) transfer to vehicle interior on “diving board” platform; and C) multiple connector mate/demate in access hatch part-task mockup.
- Understanding that S’s are not qualified KSC ground technicians, collect subjective anecdotal information and opinions from test subject as support to recorded simulation data.
- Assessment of cyber-glove with motion capture suit.

Session Results:

A. “Diving board” horizontal GSE platform positioning at and through simulated stage hatch: Motion procedure included: Trial 1: T-Pose, Transfer simulated diving board to stage vehicle hatch and position at hatch, T-Pose; Trial 2: T-Pose, Move diving board from hatch to original location, T-Pose.

B. LRU Transfer: Wireframe and weighted LRU and mass-similar simulated battery mass mockup located on simulated GSE stand moved to simulated “diving board” platform at vehicle hatch entrance for LRU translation into stage. Motion procedure included: Trial 1: T-Pose, Transfer wireframe LRU mockup from GSE shelf to diving board, T-Pose, Transfer wireframe LRU mockup from diving board to GSE shelf, T-Pose; Trial 2: Transfer LRU battery mass mockup from GSE shelf to diving board, T-Pose, Transfer battery mass mockup from diving board to GSE shelf, T-Pose.

	NASA Engineering and Safety Center Technical Assessment Report	Document #: NESC-RP-12-00774	Version: 1.0
Title: CAD Tools to Support Human Factors Design Teams		Page #: 136 of 142	

C. Electronic Cable Connector Mate/Demate: Utilizing Ares/SLS access hatch mockup, three connectors on the backside of a plate of 11 flight-like connectors were mated and demated via restricted access and fixed floor height. An additional run utilized a raised platform (8 inch high) on which the S stood. Motion procedure included: Trial 1: T-Pose, Demate three connectors on connector plate beginning with back connectors and working forward, T-Pose. Trial 2: T-Pose, Mate three connectors on backside of connector plate, T-Pose. Trial 3: T-Pose, Repeat previous motions with S standing on raised platform, T-Pose.

D. Cyber-Glove Assessment: S used right hand cyber-glove for calibration activities relative to generic motions in suit.

Notable Observations, Lessons Learned, and Actions:

- 5th percentile subject had no significant problems locating simulated diving board from initial location to hatch location. Likewise for handling wireframe or battery mass mockup.
- 5th percentile subject was challenged in reaching or observing connectors on back of plate from outside access hatch. Standing on the 8 inch platform helped.
- Subject accessed connectors from standing in front of connector plate (simulated internal operation). First time trial. Visual access improved and mate/demate task simplified. Data recorded.
- Subject had difficulties reaching over mated connectors/cables to access the three farthest connectors for demate/re-mate. Subject had difficulty demating locked connectors at the back of connector plate to the point of some hand cramping. Most operations were performed easily.
- Subject recommended: 1) Remove cable clamp fastener protrusions; 2) Would have preferred a larger hatch size; considered current mockup hatch size (10 inch diameter) to be minimum for successful access to all fasteners on horizontal plate. 3) increase floor height by 1 inch (from 8 to 9 inches) for easier access by 5th percentile person.
- Mockup issues: 1) Fastener bolts for cable restraint clamps just above connector have extended length, impacting suit glove and potentially harmful for S. Repairs completed. (it would be good to use alignment markings on connector shells). Verify connector spacing is per NASA HFE standards for ground assembly.

Next Session Plan: Two more sessions will be conducted next week to build on the database.

* **NOTE**: Test Subject identification numbers herein are temporarily assigned and will be adjusted to align with Phase One test results and documentation.

	NASA Engineering and Safety Center Technical Assessment Report	Document #: NESC-RP- 12-00774	Version: 1.0
Title: CAD Tools to Support Human Factors Design Teams		Page #: 137 of 142	

PHASE 2 MOTION CAPTURE SESSION 9

August 21, 2013

Location: MSFC Bldg. 4649; Virtual Environments Laboratory (VEL)

Personnel: Trey Perry; Marlin Williamson; Jack Stokes: Test Subject (S) # 004*

Task: Data Collection for 5th percentile Female Test Subject (S) in VEL Motion Capture Simulator

Session Plan:

- Conduct Phase 2 subtask data collection simulations utilizing 5th percentile 1988 ANSUR measured female subject and low-fidelity wire frame and solid hatch, Line Replaceable Unit (LRU) mockups, connectors and simulated hand tools.
- Collect data for A) LRU transfer through hatch from interior and exterior; B) installation/removal of simulated “diving board” horizontal GSE platform with two persons; C) handoff of LRU with 2nd S back-to-back; D) perform LRU handling motions, including lifting LRU from ground; E) remove protrusion covers and interface with hand tool; F) re-route connector cables through a 8 inch access port; G) close quarters inspection; Tool operations including hitting interior surface with hammer and operating handheld screwdriver; and (H) hand tool operation while standing inside interior volume, and I) hand tool operation while sitting in hatch of part-task mockup.
- Understanding that S’s are not qualified KSC ground technicians, collect subjective anecdotal information and opinions from test subject as support to recorded simulation data.

Session Results:

A. LRU transfer through hatch (S interior and exterior): Motion procedure included: Trial 1: T-Pose, Transfer wireframe LRU mockup from GSE shelf to hatch opening, pass LRU through hatch to 2nd S, receive LRU mockup from 2nd S and return it to GSC Stand, T-Pose; Trial 2: T-Pose, Transfer battery LRU mass mockup from GSE shelf to hatch opening, pass LRU through hatch to 2nd S, receive LRU mockup from 2nd S and return it to GSC Stand, T-Pose.

B. “Diving board” horizontal GSE platform positioning with two subjects: Motion procedure included: Trial 1: T-Pose, Transfer simulated diving board to stage vehicle hatch and position at hatch with 2nd person (non-subject), T-Pose; Trial 2: T-Pose, Move diving board from hatch to original location with 2nd person (non-subject), , T-Pose.

	NASA Engineering and Safety Center Technical Assessment Report	Document #: NESC-RP-12-00774	Version: 1.0
Title: CAD Tools to Support Human Factors Design Teams		Page #: 138 of 142	

C. LRU Transfer from Person to Person, Back-to-Back: Hand off wireframe and LRU mass mockup standing back-to-back with 2nd person (non-subject), . Motion procedure included: Trial 1: T-Pose, Holding wireframe LRU mockup, pass it to 2nd person (non-subject), by twisting around standing back-to-back, T-Pose; Trial 2: Holding LRU mass mockup, pass it to 2nd person (non-subject), by twisting around standing back-to-back, T-Pose.

D. LRU Handling Motions: ; Motion procedure included: Trial 1: T-Pose, Lift wireframe LRU positioned on floor (squatting, arms close), place LRU back on floor, T-Pose, Lift wireframe LRU (bend at waist, legs stiff, arms extended), place LRU back on floor, T-Pose; Trial 2: T-Pose, LRU mass mockup positioned on floor (squatting, arms close), place LRU back on floor, T-Pose, Lift LRU mass mockup(bend at waist, legs stiff, arms extended), place LRU back on floor, T-Pose.

E. Protective Cover Removal/Installation: Remove protective covers from interior sharp protrusions and replace. Motion procedure included: Trial 1: T-Pose, position at protrusion #1 (high position), remove cover, and stow cover; T-Pose; Trial 2: T-Pose, position at protrusion #1 (medium height position), remove cover, and stow cover; T-Pose; Trial 3: T-Pose, position at protrusion #1 (low position), remove cover, and stow cover; T-Pose; Trial 4: T-Pose, Repeat previous motions for remaining 5 protrusions, T-Pose.

F. Electronic Cable Re-route: Utilizing 8 inch access port mockup, reaching through port, re-route overlapping cables. Motion procedure included: Trial 1: T-Pose, Reach through access port and release connector # 1, move connector/ cable bundle from around overlapping cable arrangement and reposition connector at connector plate, reattach connector #1 to mating connector half on connector plate, T-Pose. Trial 2: T-Pose, Repeat previous motions for Connectors # 2 and # 3, T-Pose; Trial 3: T-Pose, Repeat previous motions in Trials 1-2 with S standing on raised platform, T-Pose.

G. Close quarters inspection (standing in interior): Access motions for close quarters inspections, followed by striking interior surface with hammer. Motion procedure included: Trial 1: T-Pose, Bend in contorted body position to view close surface, T-Pose; Trial 2: T-Pose, Strike interior surface lightly with shop hammer, T-Pose, repeat motion with greater strokes, T-Pose.

H. Hand tool operation (standing in interior): Perform typical motions for operating a hammer and a screwdriver while standing and squatting in enclosed volume. Motion procedure included: Trial 1: T-Pose, operate hammer mockup striking mockup interior surface with light strokes,, T-Pose, repeat operation with greater motion strokes, T-Pose. Trial 2: T-Pose, operate screwdriver against mockup

	NASA Engineering and Safety Center Technical Assessment Report	Document #: NESC-RP-12-00774	Version: 1.0
Title: CAD Tools to Support Human Factors Design Teams		Page #: 139 of 142	

interior surface with minimal twists, T-Pose, repeat operation with more exaggerated twisting motion, T-Pose.

I. Hand tool operation (sitting in hatch): Perform screwdriver-fastening operations around edge of hatch while seated inside hatch. Motion procedure included: Trial 1: T-Pose, reach upward to interface with fastener outside hatch and to the upper right, T-Pose; Trial 2: Twist body to access fastener outside hatch to lower right, T-Pose; Trial 3: T-Pose, Repeat trials 1 and 2 in same seated position but out the hatch and to the left of the hatch lip, T-Pose.

Notable Observations, Lessons Learned, and Actions:

- 5th percentile subject had no significant problems in performing requested motions and poses.
- 5th percentile subject was challenged in operating the screwdriver in the hatch opening zone, especially when turning fasteners on her right side. She noted that she used her forearm when working with her right hand and used wrist motion when turning with her left hand. She noted that operating hand tools while twisted created difficulties. Also, there was a body position challenge to operate hand tools and apply torque to fastener.
- Subject recommended being especially alert when handing an LRU off to make sure recipient has a firm grip on LRU prior to provider releasing grip.
- Mockup issues: 1) The wireframe stage shell mockup by design is lightweight, yet large in area. There were challenges when it had to be moved with the wire staying fastened in the “Moseman Puck” nodes. 2) The previously sharp-edged fasteners in the cable clamps of the connector mockup were filed down to prevent damage to S's.

Next Session Plan:

- Final session will address these motions and poses for the 95th percentile S, to be conducted on August 23 to build on the database.

* **NOTE:** Test Subject identification numbers herein are temporarily assigned and will be adjusted to align with Phase One test results and documentation.

	NASA Engineering and Safety Center Technical Assessment Report	Document #: NESC-RP-12-00774	Version: 1.0
Title: CAD Tools to Support Human Factors Design Teams		Page #: 140 of 142	

PHASE 2 MOTION CAPTURE SESSION 10

August 21, 2013

Location: MSFC Bldg. 4649; Virtual Environments Laboratory (VEL)

Personnel: Trey Perry; Marlin Williamson; Jack Stokes: Test Subject (S) # 005*

Task: Data Collection for 95th percentile Male Test Subject (S) in VEL Motion Capture Simulator

Session Plan:

- Conduct Phase 2 subtask data collection simulations utilizing 95th percentile 1988 ANSUR measured male subject and low-fidelity wire frame and solid hatch and Line Replaceable Unit (LRU) mockups.
- Collect data for A) LRU transfer through hatch from interior and exterior; B) installation/removal of simulated “diving board” horizontal GSE platform with two persons; C) handoff of LRU with 2nd S back-to-back; D) perform LRU handling motions, including lifting LRU from ground; E) remove protrusion covers and interface with hand tool; F) re-route connector cables through a 8 inch access port; G) close quarters inspection; Tool operations including hitting interior surface with hammer and operating handheld screwdriver; and (H) hand tool operation while standing inside interior volume, and I) hand tool operation while sitting in hatch of part-task mockup.
- Understanding that S’s are not qualified KSC ground technicians, collect subjective anecdotal information and opinions from test subject as support to recorded simulation data.

Session Results:

A. LRU transfer through hatch (S interior and exterior): Motion procedure included: Trial 1: T-Pose, Transfer wireframe LRU mockup from GSE shelf to hatch opening, pass LRU through hatch to 2nd S, receive LRU mockup from 2nd S and return it to GSC Stand, T-Pose; Trial 2: T-Pose, Transfer battery LRU mass mockup from GSE shelf to hatch opening, pass LRU through hatch to 2nd S, receive LRU mockup from 2nd S and return it to GSC Stand, T-Pose.

B. “Diving board” horizontal GSE platform positioning with two subjects: Motion procedure included: Trial 1: T-Pose, Transfer simulated diving board to stage vehicle hatch and position at hatch with 2nd person (non-subject), T-Pose; Trial 2: T-Pose, Move diving board from hatch to original location with 2nd person (non-subject), , T-Pose.

	NASA Engineering and Safety Center Technical Assessment Report	Document #: NESC-RP-12-00774	Version: 1.0
Title: CAD Tools to Support Human Factors Design Teams		Page #: 141 of 142	

C. LRU Transfer from Person to Person, Back-to-Back: Hand off wireframe and LRU mass mockup standing back-to-back with 2nd person (non-subject). Motion procedure included: Trial 1: T-Pose, Holding wireframe LRU mockup, pass it to 2nd person (non-subject), by twisting around standing back-to-back, T-Pose; Trial 2: Holding LRU mass mockup, pass it to 2nd person (non-subject), by twisting around standing back-to-back, T-Pose.

D. LRU Handling Motions: ; Motion procedure included: Trial 1: T-Pose, Lift wireframe LRU positioned on floor (squatting, arms close), place LRU back on floor, T-Pose, Lift wireframe LRU (bend at waist, legs stiff, arms extended), place LRU back on floor, T-Pose; Trial 2: T-Pose, LRU mass mockup positioned on floor (squatting, arms close), place LRU back on floor, T-Pose, Lift LRU mass mockup (bend at waist, legs stiff, arms extended), place LRU back on floor, T-Pose.

E. Protective Cover Removal/Installation: Remove protective covers from interior sharp protrusions and replace. Motion procedure included: Trial 1: T-Pose, position at protrusion #1 (high position), remove cover, and stow cover; T-Pose; Trial 2: T-Pose, position at protrusion #1 (medium height position), remove cover, and stow cover; T-Pose; Trial 3: T-Pose, position at protrusion #1 (low position), remove cover, and stow cover; T-Pose; Trial 4: T-Pose, Repeat previous motions for remaining 5 protrusions, T-Pose.

F. Electronic Cable Re-route: Utilizing 8 inch access port mockup, reaching through port, re-route overlapping cables. Motion procedure included: Trial 1: T-Pose, Reach through access port and release connector # 1, move connector/ cable bundle from around overlapping cable arrangement and reposition connector at connector plate, reattach connector #1 to mating connector half on connector plate, T-Pose. Trial 2: T-Pose, Repeat previous motions for Connectors # 2 and # 3, T-Pose; Trial 3: T-Pose, Repeat previous motions in Trials 1-2 with S standing on raised platform, T-Pose.

G. Hammer Operation (standing in interior): Access motions for striking interior surface with hammer. Motion procedure included: Trial 1: T-Pose, Strike interior surface lightly with shop hammer, T-Pose, repeat motion with greater strokes, T-Pose.

H. Hand tool operation (standing in interior): Perform typical motions for operating a hammer and a screwdriver while standing and squatting in enclosed volume. Motion procedure included: Trial 1: T-Pose, operate hammer mockup striking mockup interior surface with light strokes,, T-Pose, repeat operation with greater motion strokes, T-Pose. Trial 2: T-Pose, operate screwdriver against mockup interior surface with minimal twists, T-Pose.

	NASA Engineering and Safety Center Technical Assessment Report	Document #: NESC-RP-12-00774	Version: 1.0
Title: CAD Tools to Support Human Factors Design Teams		Page #: 142 of 142	

I. Hand tool operation (sitting in hatch): Perform screwdriver-fastening operations around edge of hatch while seated inside hatch. Motion procedure included: Trial 1: T-Pose, reach upward to interface with fastener outside hatch and to the upper right, T-Pose; Trial 2: Twist body to access fastener outside hatch to lower right, T-Pose; Trial 3: T-Pose, Repeat trials 1 and 2 in same seated position but out the hatch and to the left of the hatch lip, T-Pose.

Notable Observations, Lessons Learned, and Actions:

- 95th percentile subject showed no difficulties with the tasks of the session with the exception of two tasks.
- 95th percentile subject was seriously challenged (rated task a 5 on a scale of 1(good) to 5 (bad)) while trying to access and operate connector #2 because of extra close tolerances for his hands and alignment issues (visual and tactile) and close tolerances on that specific connector. Subject had no significant difficulties reaching into port to untangle remaining cable runs.
- Subject rated LRU mass mockup a 4 on a scale of 1(good) to 5 (bad) because of back strain when in the challenged lifting position (e.g., legs straight, bend at waist, arms extended to lift). Task did not provide injury to subject and permitted gathering data at the upper end of motion acceptability.
- Subject found no complaints in stepping on or operating in the raised 6 inch platform with anti-skid surface.
- Subject noted that when attempting to operate fastener “inside” the stage part-task mockup he was partially blinded by sunlight streaming down through the roof panels of the facility. Was listed as a consideration for glare protection when operating fine dexterity hand operations.
- Mockup issues: 1) flexibility in wire-frame stage shell wall continued to deteriorate and has reached a need for proper shop technician before use again..

Next Session Plan:

- This completes the contractually obligated 10 trials. If the opportunity arises where it makes sense to collect additional data a subsequent trial(s) will be scheduled and performed, within task scope.

NOTE: Test subjects performed well and completed their task performance within expectations. All should be commended.

REPORT DOCUMENTATION PAGE

*Form Approved
OMB No. 0704-0188*

The public reporting burden for this collection of information is estimated to average 1 hour per response, including the time for reviewing instructions, searching existing data sources, gathering and maintaining the data needed, and completing and reviewing the collection of information. Send comments regarding this burden estimate or any other aspect of this collection of information, including suggestions for reducing this burden, to Department of Defense, Washington Headquarters Services, Directorate for Information Operations and Reports (0704-0188), 1215 Jefferson Davis Highway, Suite 1204, Arlington, VA 22202-4302. Respondents should be aware that notwithstanding any other provision of law, no person shall be subject to any penalty for failing to comply with a collection of information if it does not display a currently valid OMB control number.
PLEASE DO NOT RETURN YOUR FORM TO THE ABOVE ADDRESS.

1. REPORT DATE (DD-MM-YYYY) 01-05 - 2014			2. REPORT TYPE Technical Memorandum		3. DATES COVERED (From - To) April 2013 - April 2014	
4. TITLE AND SUBTITLE Computer-Aided Design (CAD) Tools to Support the Human Factors Design Teams					5a. CONTRACT NUMBER	
					5b. GRANT NUMBER	
					5c. PROGRAM ELEMENT NUMBER	
6. AUTHOR(S) Null, Cynthia H.; Jackson, Mariea Dunn; Perry, Trey; Quick, Jason C.; Stokes, Jack W.					5d. PROJECT NUMBER	
					5e. TASK NUMBER	
					5f. WORK UNIT NUMBER 869021.05.07.01.18	
7. PERFORMING ORGANIZATION NAME(S) AND ADDRESS(ES) NASA Langley Research Center Hampton, VA 23681-2199					8. PERFORMING ORGANIZATION REPORT NUMBER L-20417 NESC-RP-12-00774	
9. SPONSORING/MONITORING AGENCY NAME(S) AND ADDRESS(ES) National Aeronautics and Space Administration Washington, DC 20546-0001					10. SPONSOR/MONITOR'S ACRONYM(S) NASA	
					11. SPONSOR/MONITOR'S REPORT NUMBER(S) NASA/TM-2014-218263	
12. DISTRIBUTION/AVAILABILITY STATEMENT Unclassified - Unlimited Subject Category 61 Computer Programming and Software Availability: NASA CASI (443) 757-5802						
13. SUPPLEMENTARY NOTES						
14. ABSTRACT The scope of this assessment was to develop a library of basic 1-Gravity (G) human posture and motion elements used to construct complex virtual simulations of ground processing and maintenance tasks for spaceflight vehicles, including launch vehicles, crewed spacecraft, robotic spacecraft, satellites, and other payloads. The report herein describes the task, its purpose, performance, findings, NASA Engineering and Safety Center (NESC) recommendations, and conclusions in the definition and assemblage of the postures and motions database (PMD).						
15. SUBJECT TERMS Computer-Aided Design; NASA Engineering and Safety Center; Postures and motions database; Human factors						
16. SECURITY CLASSIFICATION OF:			17. LIMITATION OF ABSTRACT	18. NUMBER OF PAGES	19a. NAME OF RESPONSIBLE PERSON	
a. REPORT	b. ABSTRACT	c. THIS PAGE			19b. TELEPHONE NUMBER (Include area code)	
U	U	U	UU	147	STI Help Desk (email: help@sti.nasa.gov) (443) 757-5802	