

# A comparison between high-energy radiation background models and SPENVIS trapped-particle radiation models

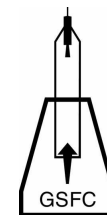

## GOAL:

Determine the background rate due to cosmogenic and terrestrial background radiation for the next generation of X-ray and Cosmic-Ray missions.

**SPENVIS use is highlighted.**

John Krizmanic

CRESST/USRA/NASA/GSFC



May 22, 2013

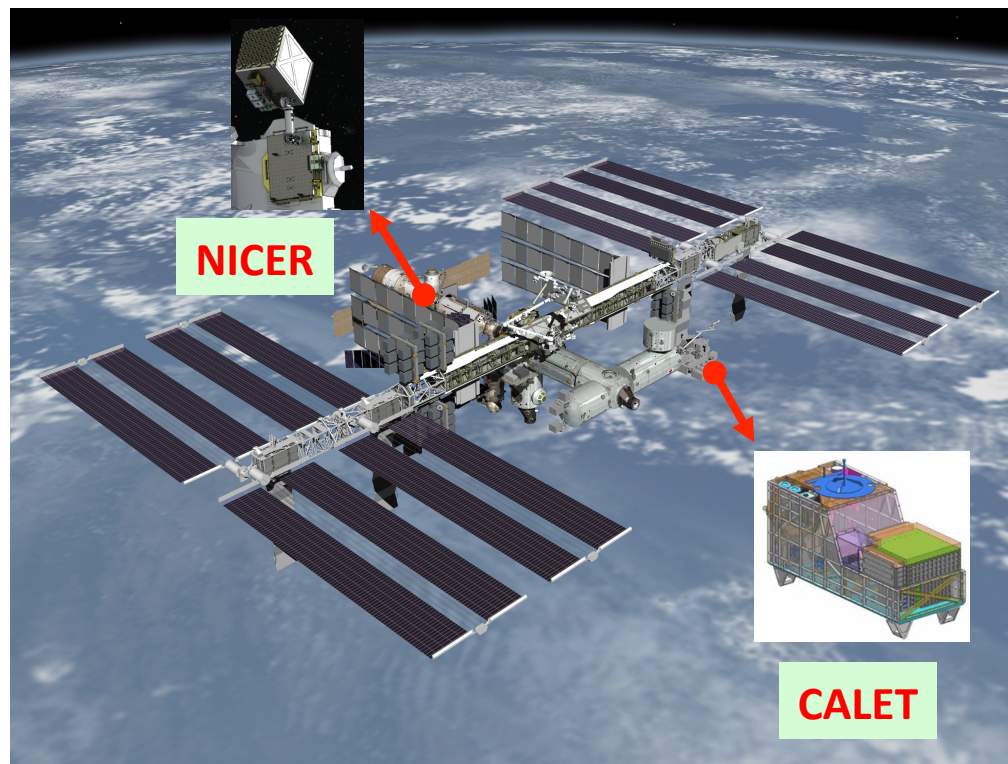

Spennis User Workshop 2013

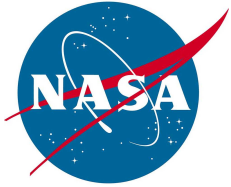

# The Problem

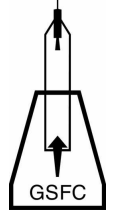

- The next generation of space-based X-ray and Cosmic-ray experiments are designed for unprecedented signal sensitivity → **high background rejection**.
- The **magnitude** of the background must be determined as well as **mitigation strategies developed**, both in the choice of instrument design and signal processing capability.
- Simulation packages (GEANT) can be used to accurately determine the impact of background radiation **if the spectra of all backgrounds are known (and the Fermi team has developed an extensive set of background models** (Mizuno et al., ApJ 614)).
- This problem is more acute for the new X-ray experiments, historically it has been *difficult to simulate the radiation background that mimic X-ray signals* with GEANT and the low-energy background in low-Earth orbit, e.g. ISS, is more uncertain.
- For mission planning, SPENVIS has proved an invaluable tool to determine the orbit fraction at specific geomagnetic latitude bands *and* determine where the trapped-particle flux is too large to allow physics operation → helps define duty cycle.
- For X-ray missions, better knowledge of the low-energy (electron and proton) terrestrial background is needed ... can SPENVIS help?

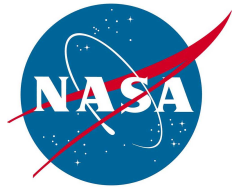

# Background Flux Modeling

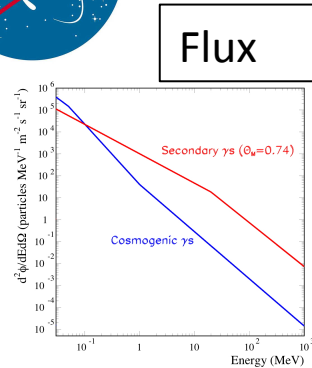

Instrument Modeling

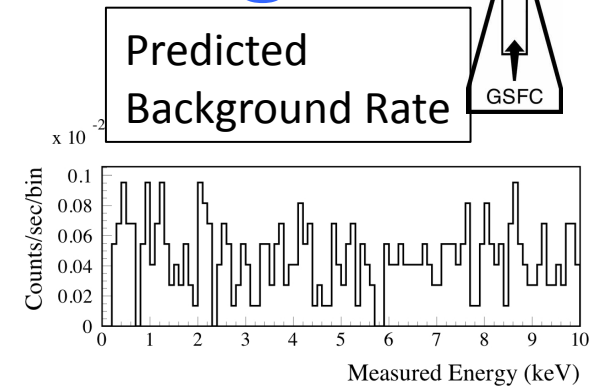
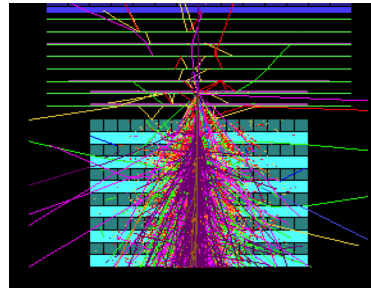

- Experiments in orbit are irradiated by multiple sources:
  - Cosmic Ray Primaries: protons, helium,  $e^\pm$ , **heavy nuclei**.
  - **Diffuse X-ray and Gamma-ray background**.
  - **Atmospheric 'Backsplash' and trapped particles: protons, photons,  $e^\pm$ , neutrons.**
  - **High values of trapped-particle flux preclude science operation.**
- Fluxes and spectra depend on orbit parameters (altitude and geomagnetic latitude) and solar activity (Solar Modulation Factor)
- Fluxes and spectra sampled by radiation-sensitive detectors also depends on surrounding material, which acts as both a shield and a target.
- Particle physics based Monte Carlo simulations provide mechanism to assess impact of radiation background on an experimental measurement.

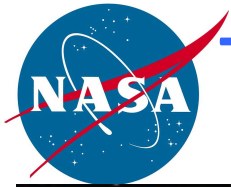

# The Neutron star Interior Composition Explorer (NICER)

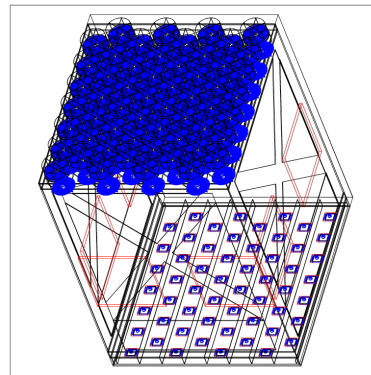
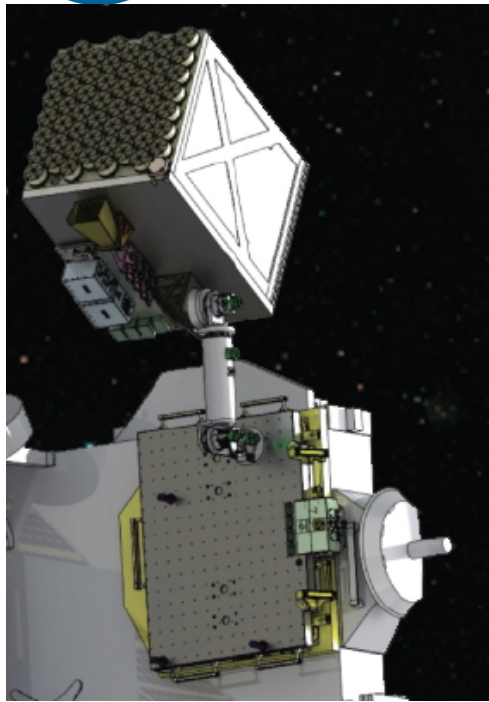
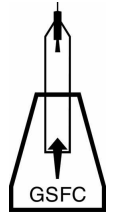

Simplified MGEANT model

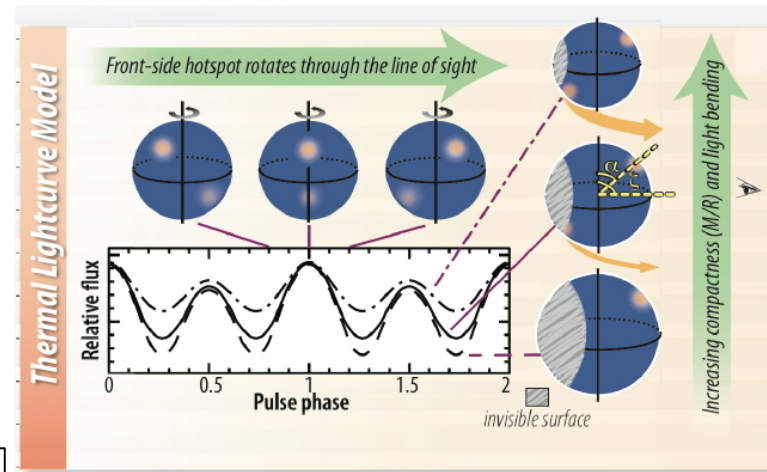

NICER is an array of 56 individual telescopes, each with grazing-incident optics and a silicon drift detector with a  $\sim 1.1$  m separation.

X-ray signal energy range: 200 eV – 10 keV

NICER will measure radii of neutron stars, which reveals the interior composition.

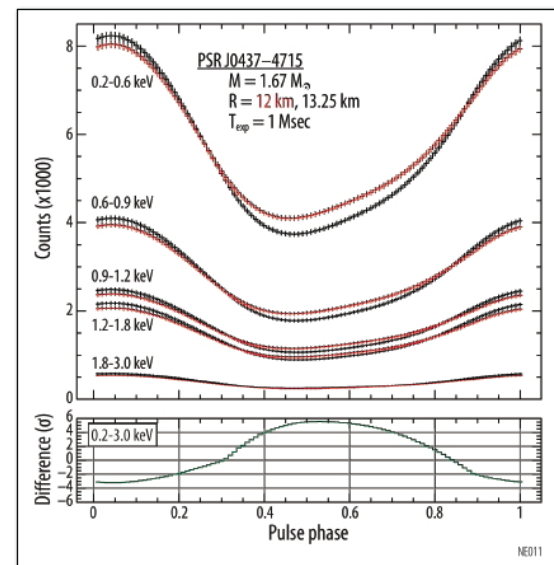



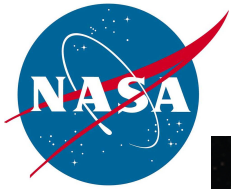

# High-Fidelity Mass Models

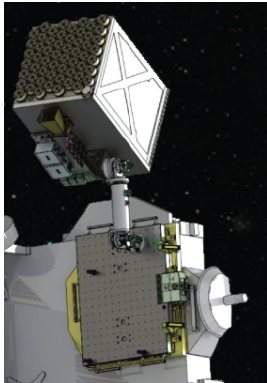
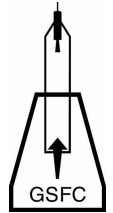

1.1 m

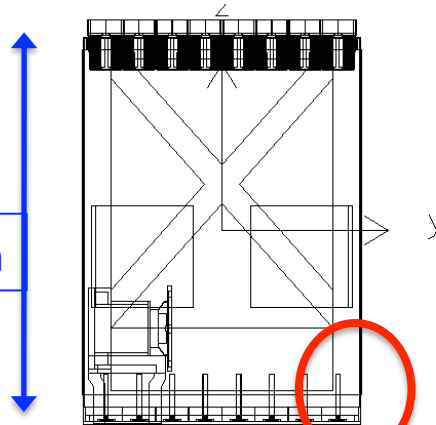

Short shields

Developed by Steve Sturner @ GSFC

- MGEANT mass model based upon CAD instrument model.
- Materials in model match that in instrument, i.e. alloys vs pure Al (X-ray fluorescence).
- Care taken to model detector housing & materials.

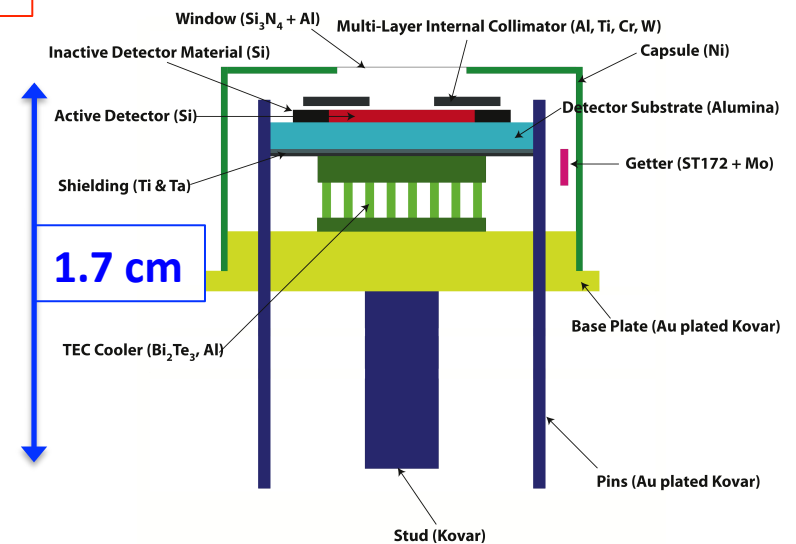
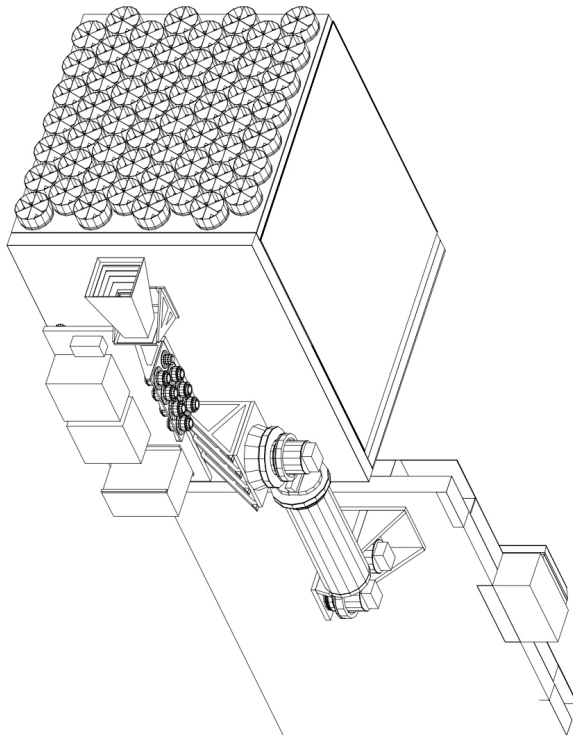

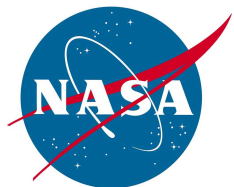

# MGEANT Modeling

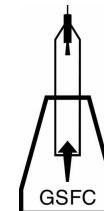

We are using MGEANT, which is based upon GEANT3, but with improvements:

- **MGEANT** uses **GLECS**: an extension program for the [GEANT3](#) simulation package that incorporates improved physics into the simulation of Compton and Rayleigh scattering.
- In GLECS, the total cross sections for an element are interpolated from the Evaluated Photon Data Library (EPDL [2]) tables. These data include electron binding effects and are valid from 10 eV to 100 GeV.
- MGEANT used for TGRS on WIND, GRIS, and **SPI on Integral**.
- *“We have successfully used MGEANT with the lower energy bounds set as low as 200 eV.”*  
– MGEANT Manual.
- **For GEMS ¼ atm DME polarimeter, comparison to GEANT4 simulations and laboratory data show excellent agreement (NIM paper currently being written).**

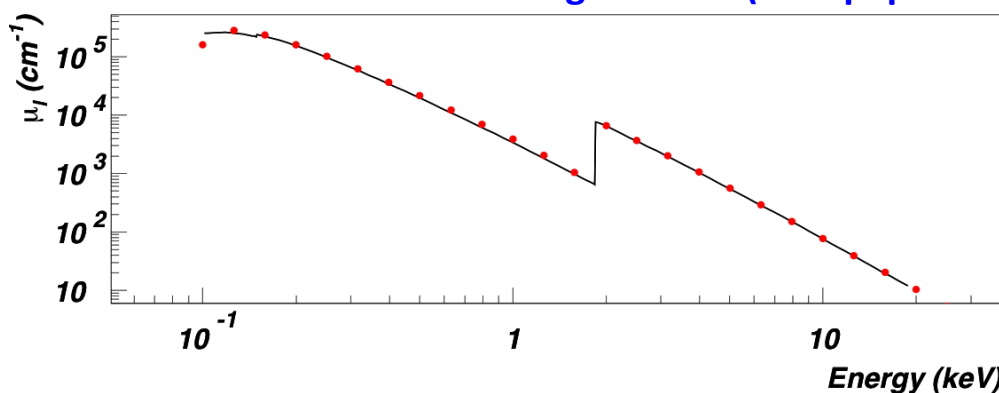

Curves: NIST XCOM values  
Red Points:  $\sigma$ -sampling > 200 eV  
Blue Points:  $\sigma$ -sampling > 1 keV  
 $\mu_1 = \rho \sigma_{\text{Tot}} / (\text{uA}), u \approx 1.66 \times 10^{-24} \text{ g}$

Comparison of silicon linear attenuation coefficient (dots) to NIST values.

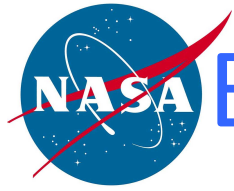

# Background Radiation Models

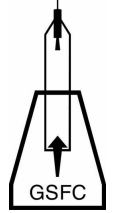

- based upon Mizuno et al., ApJ 614 (2004) & Fermi updates and *are data driven*.
- includes dependence on geomagnetic latitude, extended to lower energy for some.
- **considers background sources outside of regions of high fluxes of trapped particles.**

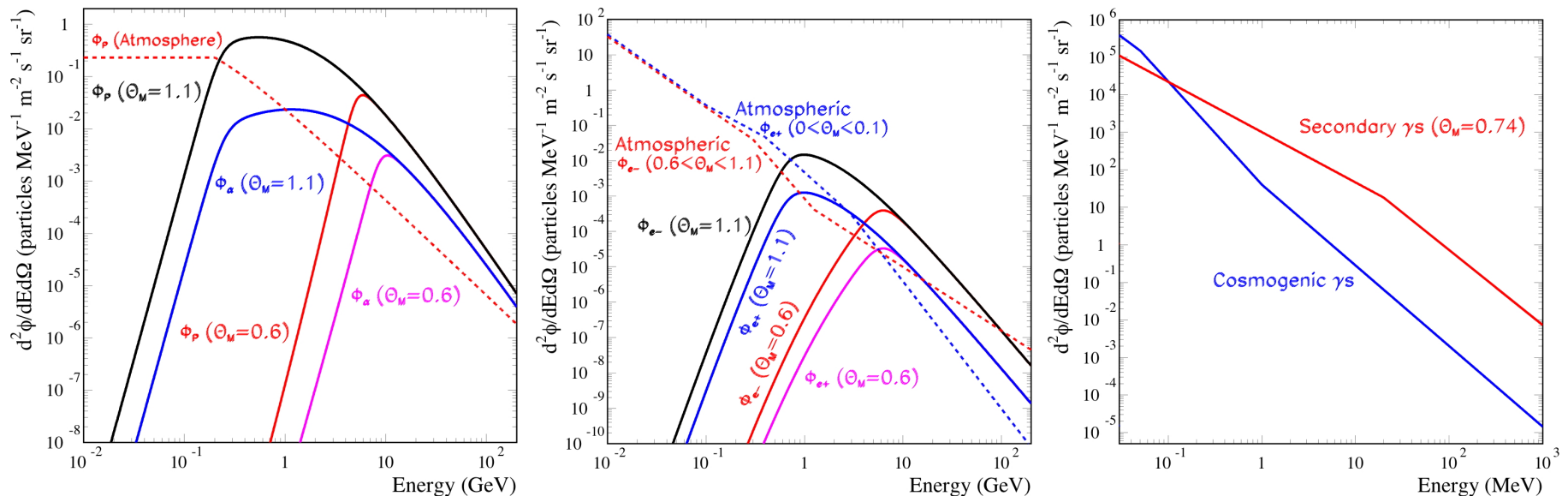

- these spectra can then be used in GEANT to generate background event files.
- the definition of the event generating surface and the integral flux defines an event rate.
- event selection criteria can then be applied to minimizing the background rate while maximizing the signal acceptance, requires a instrument response model.

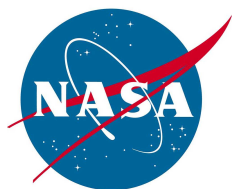

# Secondary Proton Model

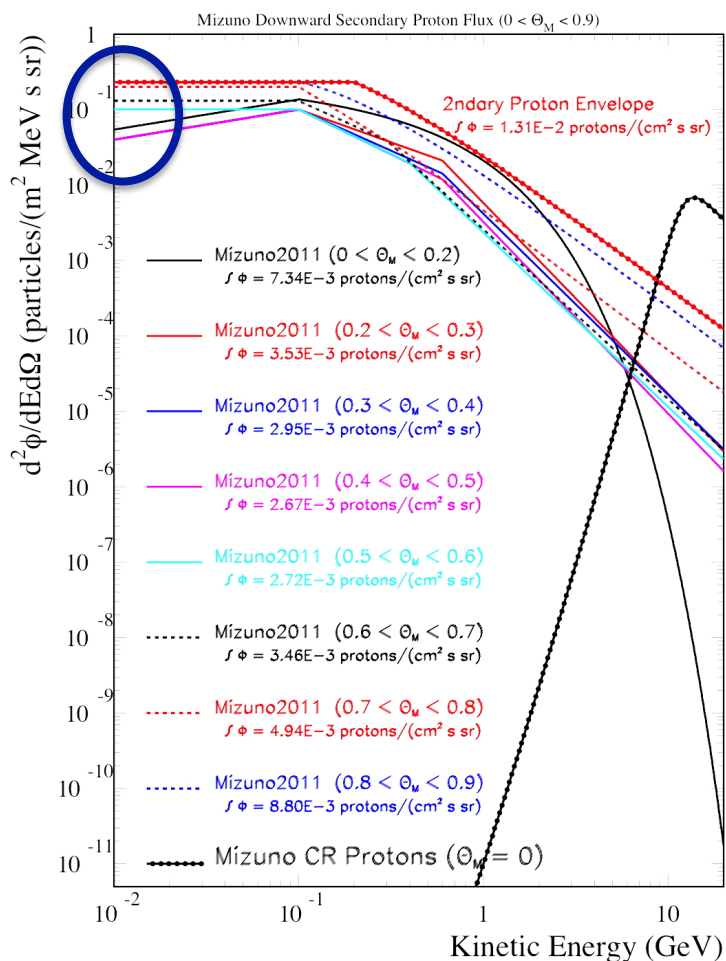
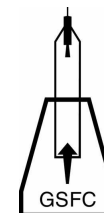

**Secondary Proton Flux is a function of geomagnetic location (& up  $\neq$  down at high  $\theta_M$ )**

- Integral flux goes from 2.7  $\rightarrow$  8.8 (rel units).
- Spectral shapes rather similar.
- Define envelope function to throw MC events, then need to scale by relative flux in appropriate bands of geomagnetic latitude.

MIZUNO ET AL.

TABLE 1  
 MODEL PARAMETERS FOR PROTON SECONDARY FLUX AT SATELLITE ALTITUDE, BASED ON AMS DATA

Region	Direction	Model	Parameters <sup>a</sup>
$0.0 \leq \theta_M \leq 0.2$ .....	Downward/Upward	Cutoff PL	0.136/0.123/0.155/0.51
$0.2 \leq \theta_M \leq 0.3$ .....	Downward/Upward	Broken PL	0.1/0.87/600/2.53
$0.3 \leq \theta_M \leq 0.4$ .....	Downward/Upward	Broken PL	0.1/1.09/600/2.40
$0.4 \leq \theta_M \leq 0.5$ .....	Downward/Upward	Broken PL	0.1/1.19/600/2.54
$0.5 \leq \theta_M \leq 0.6$ .....	Downward/Upward	Broken PL	0.1/1.18/400/2.31
$0.6 \leq \theta_M \leq 0.7$ .....	Downward	Broken PL	0.13/1.1/300/2.25
	Upward	...	0.13/1.1/300/2.95
$0.7 \leq \theta_M \leq 0.8$ .....	Downward	Broken PL	0.2/1.5/400/1.85
	Upward	...	0.2/1.5/400/4.16
$0.8 \leq \theta_M \leq 0.9$ .....	Downward	Cutoff PL	0.23/0.017/1.83/0.177
	Upward	Broken PL	0.23/1.53/400/4.68
$0.9 \leq \theta_M \leq 1.0$ .....	Downward	Cutoff PL	0.44/0.037/1.98/0.21
	Upward	Broken PL	0.44/2.25/400/3.09

<sup>a</sup>  $F_0/a/E_{bk}(\text{GeV})/b$  for the broken PL (PL) model (eq. [7]) and  $F_0/F_1/a/E_c(\text{GeV})$  for the cutoff PL model (eq. [8]).  $F_0$  and  $F_1$  are given in counts s<sup>-1</sup> m<sup>-2</sup> sr<sup>-1</sup> MeV<sup>-1</sup>.



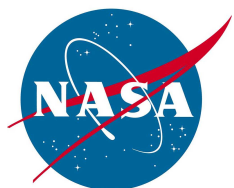

# SPENVIS use I:

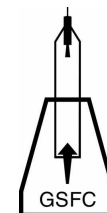

## Defining geomagnetic orbit fraction

- Using the 'Coordinate generators/Spacecraft trajectories' tool the orbit position parameters (latitude & longitude) can be generated in equal time spacing based on altitude (400 km), inclination (51.6°), and duration (30 days).
- Assuming a location of the Earth's magnetic north pole ( $\lambda_p=85.9, \phi_p=147.0$ ) the geomagnetic latitude ( $\Lambda$ ) for a given orbit ( $\lambda, \phi$ ) can be calculated:

$$\sin \Lambda = \sin \lambda \sin \lambda_p + \cos \lambda \cos \lambda_p \cos(\phi - \phi_p)$$

**The geomagnetic latitude fractions can be thus calculated and be used to determine the background rate vs geomagnetic latitude.**

GeoMagnetic Latitude Bin (radians)	Fraction of Orbit within Bin	Running Total
0 – 0.1	0.082	0.082
0.1 – 0.2	0.083	0.165
0.2 – 0.3	0.084	0.249
0.3 – 0.4	0.086	0.335
0.4 – 0.5	0.089	0.424
0.5 – 0.6	0.095	0.519
0.6 – 0.7	0.107	0.626
0.7 – 0.8	0.134	0.76
0.8 – 0.9	0.173	0.933
0.9 – 1.0	0.067	1

**ISS Orbit fraction versus Geomagnetic Latitude obtained from Spenvis Analysis**

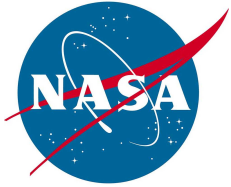

# SPENVIS use II:

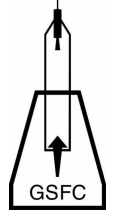

## Excluding regions of high flux of trapped particles

- Using the 'Radiation sources and effects /Trapped proton and electron fluxes' tool, the integral flux vs energy of trapped electron (AE8) and protons (AP8) can get generated as a function of the orbit position parameters (latitude & longitude).
- Selection of a maximum integral flux vs position can then be used to exclude regions of the orbit where trapped flux is too high to allow science operation → **duty cycle**.
- Note: ROSAT (53° inc, 580 km) was able to operate in upper high flux region.

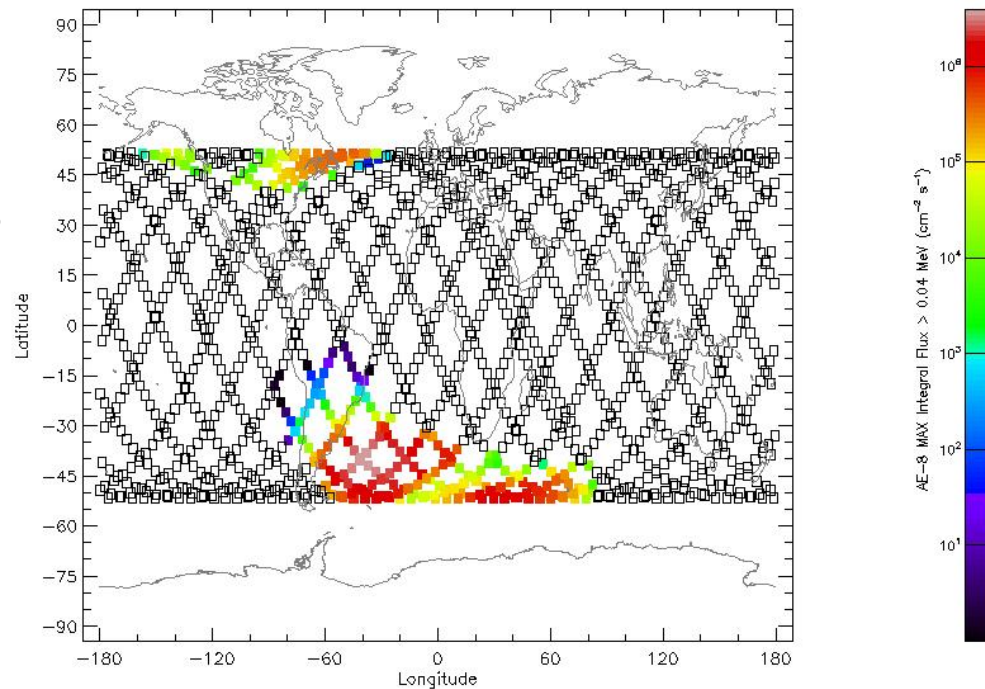

AE8 (SolarMax) map of integral electron flux ( $E_{\text{Elec}} \geq 40$  keV) for 1 day ISS orbit.

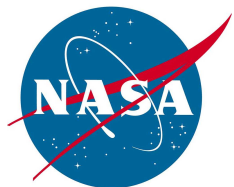

# Duty Cycle Determination

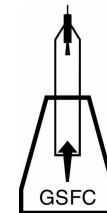

Using the results of the NICER background modeling (outside of regions of high trapped particle: electrons  $> 1 \text{ Hz/cm}^2$  above 40 keV; protons  $> 1 \text{ Hz/cm}^2$  above 100 keV) and excluding the trapped particle flux regions  $\rightarrow$  **duty cycle**.

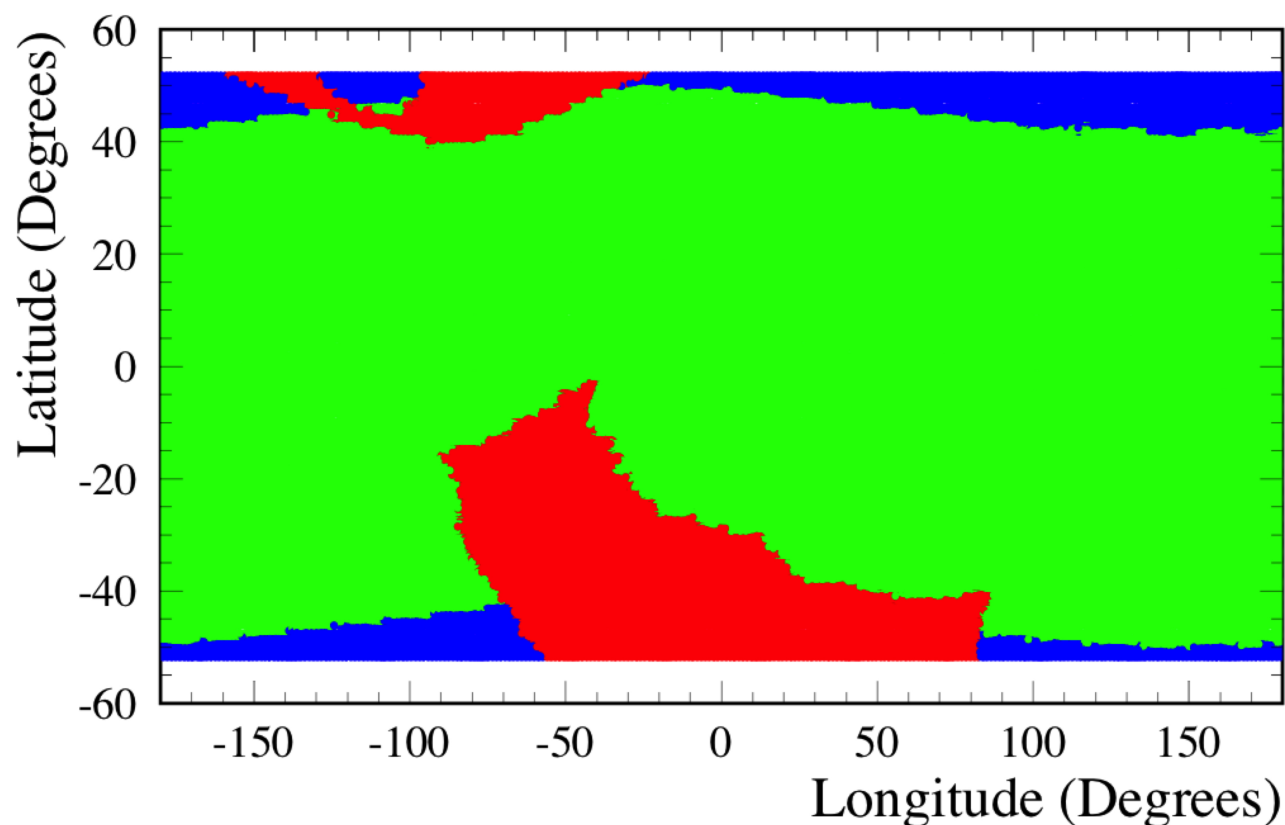

## Legend

**Green:** background  $< 0.01 \text{ cts/s/keV}$   
**66% of ISS orbit**

**Blue:** background  $\geq 0.01 \text{ cts/s/keV}$   
**17% of ISS orbit**

**Red:** trapped particle flux  $> 1 \text{ Hz/cm}^2$   
**17% of ISS orbit**

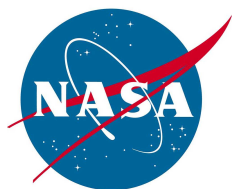

# Background Rate vs GeoMag Lat

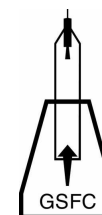

GeoMagnetic Latitude Bin (radians)	Fraction of Orbit within Bin	Orbit Running Total	Background Rate within Bin (CPS) ( $0.2 \text{ keV} \leq E_{\text{DEP}} \leq 2 \text{ keV}$ ) Goal: < 0.02 CPS	Background Rate within Bin (CPS) ( $2 \text{ keV} \leq E_{\text{DEP}} \leq 10 \text{ keV}$ ) Goal: < 0.08 CPS
0 – 0.1	0.082	0.082	1.35E-2	4.98E-2
0.1 – 0.2	0.083	0.165	1.36E-2	5.01E-2
0.2 – 0.3	0.084	0.249	1.37E-2	5.03E-2
0.3 – 0.4	0.086	0.335	1.39E-2	5.14E-2
0.4 – 0.5	0.089	0.424	1.45E-2	5.41E-2
0.5 – 0.6	0.095	0.519	1.45E-2	5.40E-2
0.6 – 0.7	0.107	0.626	1.70E-2	6.48E-2
0.7 – 0.8	0.134	0.760	1.83E-2	7.15E-2
0.8 – 0.9	0.173	0.933	2.14E-2	8.59E-2
0.9 – 1.0	0.067	1	2.76E-2	1.14E-1



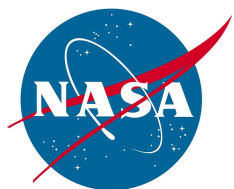

# SPENVIS Use III: Low-energy flux guidance

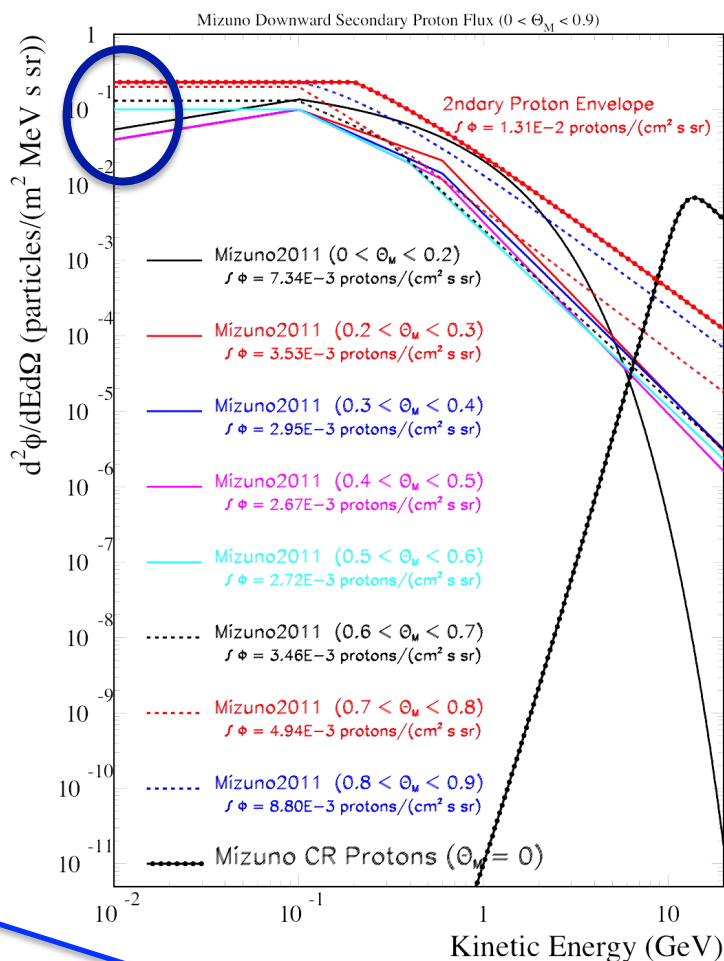
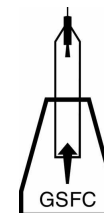

Fermi-based background flux models extrapolation to low-energies (Fermi interested in  $> 10$  MeV).

Radiation Source	Energy Range
Cosmic Ray Primaries (p, $\alpha$ , $e^-$ , $e^+$ )	100 MeV – 200 GeV
Cosmogenic Photons	1 keV – 100 GeV
Atmospheric Secondaries (p, n, $e^-$ , $e^+$ )	10 MeV – 10 GeV
Atmospheric Photons	30 keV – 100 GeV

**Need to extend flux models to lower energies, where *input spectrum*  $\times$  *instrument response*  $\rightarrow$  0 signal** (analysis shows this is true for high energies and is mainly true at lower energies, but would like to extend further down in E).

**Electron CSDA range in Al:**

100 keV: 70  $\mu$ m; 1 MeV: 2 mm; 10 MeV: 2.2 cm

**200 eV – 10 keV range**

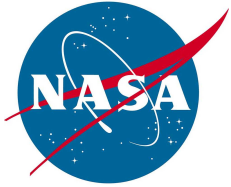

# SPENVIS Flux Reports

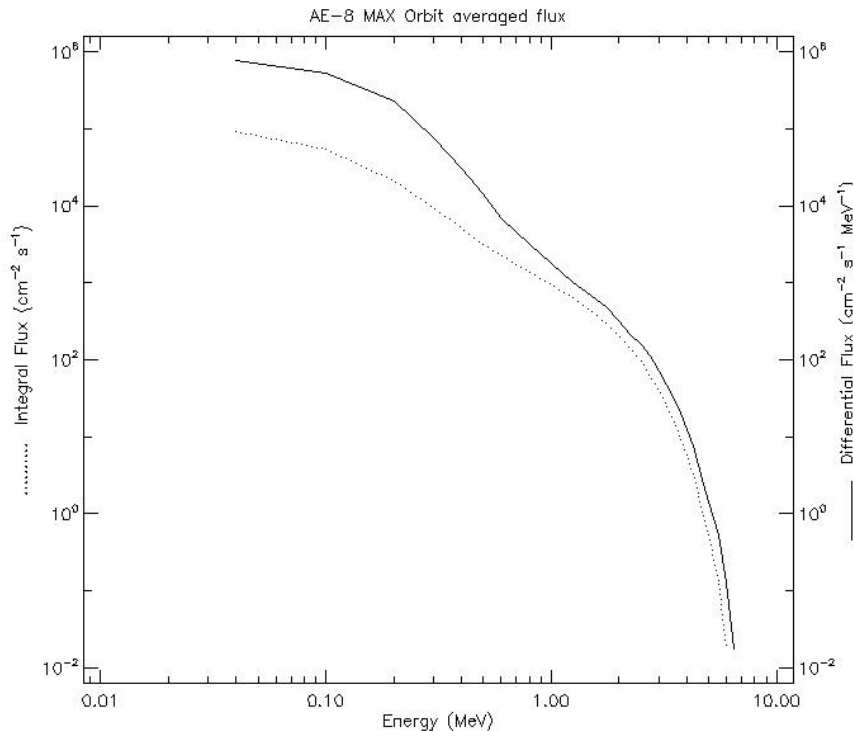
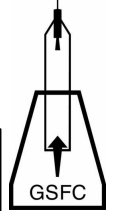

ISS Orbit averaged differential and integral electron flux. Leads to over-prediction of background rate.

- SPENVIS models go to lower E:
  - 40 keV for electrons.
  - 100 keV for protons.
- To assess low-energy contribution to background, need to get differential flux as a function of orbit position, where trapped radiation flux is falling to 0.
- SPENVIS reports integral electron and proton trapped flux as a function of position, but LSB is  $1 \text{ Hz/cm}^2$  assumed isotropic
  - $8 \times 10^{-2} \text{ particles}/(\text{s sr cm}^2)$
- Outside areas of trapped particles integral flux range (for ISS):
  - <  $1 \times 10^{-2} - 2 \times 10^{-1} \text{ particles}/(\text{s sr cm}^2)$  assuming  $E_{\text{MIN}} \approx 10 \text{ MeV}$ .

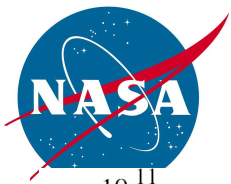

# Flux Extrapolation to Low-E

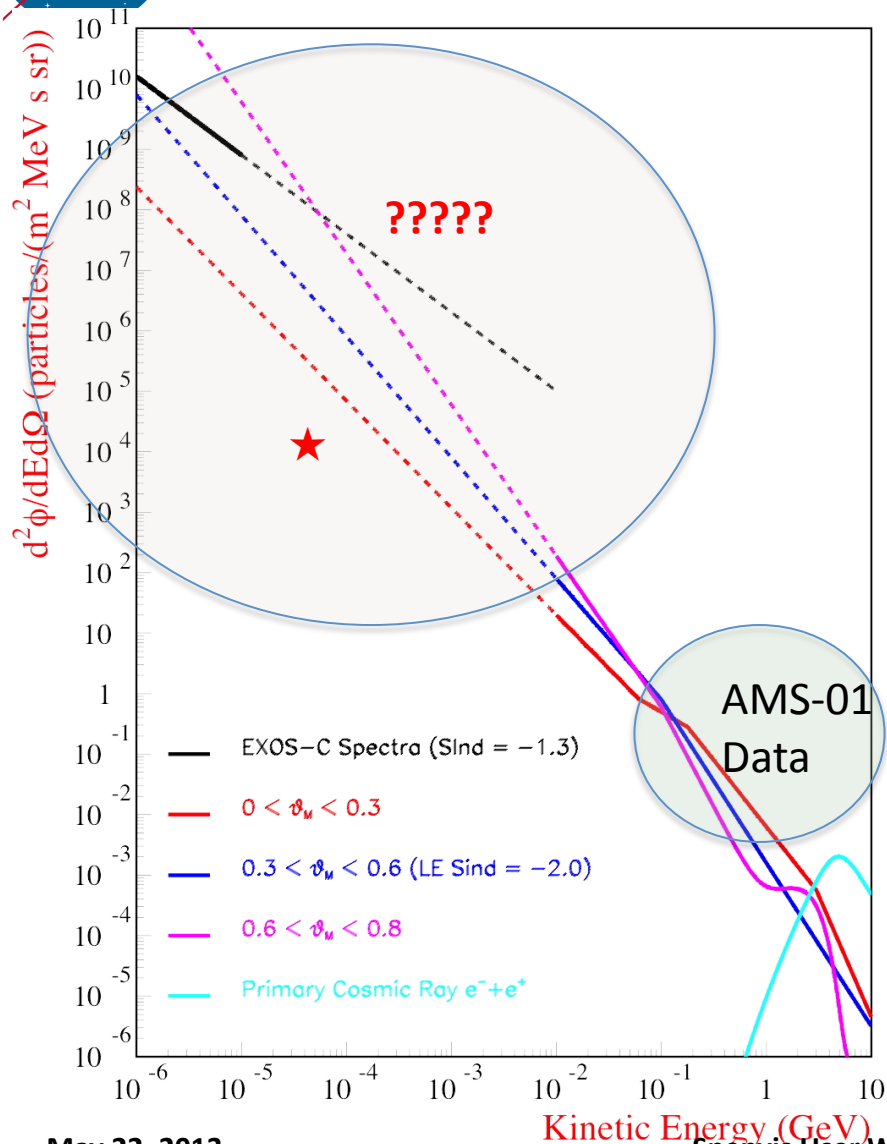
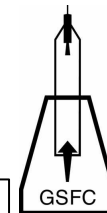

**Atmospheric 'secondary'  $e^+ e^-$**

- Outside regions of high flux of trapped particles.
- Spectra defined by AMS-01 measurements with  $E > 100$  MeV, but with extrapolation to 10 MeV.
- Extrapolation to 10 keV yields wide range of flux values.
- Background rate prediction thus vary over a wide range.

★ Estimate scaling low flux bit of AE8max model of  $1 \text{ Hz/cm}^2$  in a  $0.04 - 0.1 \text{ MeV}$  energy bin.

→ Naïve extrapolations to lower E overpredicts the background.

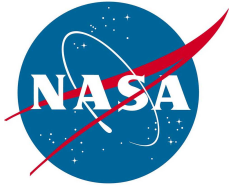

# Summary

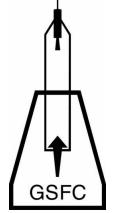

- We have been using GEANT with high-fidelity mass models and robust background flux models to predict the background rate in the next generation of X-ray & Cosmic-ray experiments: [the flux models and procedures are robust](#).
- For X-ray mission modeling, we would like to extend our background models to lower energy (down to  $\sim 100$  keV), and SPENVIS offers the opportunity to do this extrapolation.
- Future work:
  - Understand the fidelity of the SPENVIS trapped particle radiation models:
    - Are the SPENVIS trapped flux models of sufficient accuracy to provide flux predictions at low-flux edge of the trapped radiation?
    - As presented at this workshop, the AE9 and AP9 updates provide differential spectra and reports the trapped radiation flux to a factor of 10 lower than the AE8 and AP8 models. This offers the opportunity to use the position dependent flux predictions for the trapped particle models set low energy flux limits at the low trapped particle flux boundaries defined by the lowest non-zero reported flux for the trapped radiation.



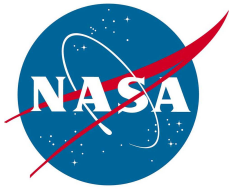

# CALET: Calorimetric Electron Telescope (New Cosmic Ray ISS Mission)

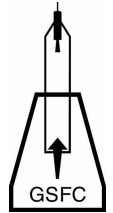

## Main Telescope: Calorimeter (CAL)

- Electrons: 1 GeV – 20 TeV
- Gamma-rays: 10 GeV – 10\* TeV  
(Gamma-ray Bursts: > 1 GeV)
- Protons and Heavy Ions:  
10's of GeV – 1,000\* TeV
- Ultra Heavy (Z>28) nuclei:  
E > 600 MeV/nucleon

## Gamma-ray Burst Monitor (CGBM)

- X-rays/Soft Gamma-rays: 7keV – 20MeV

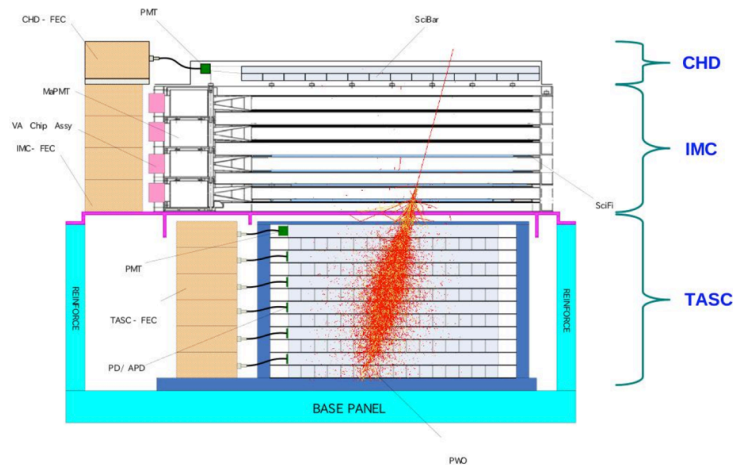
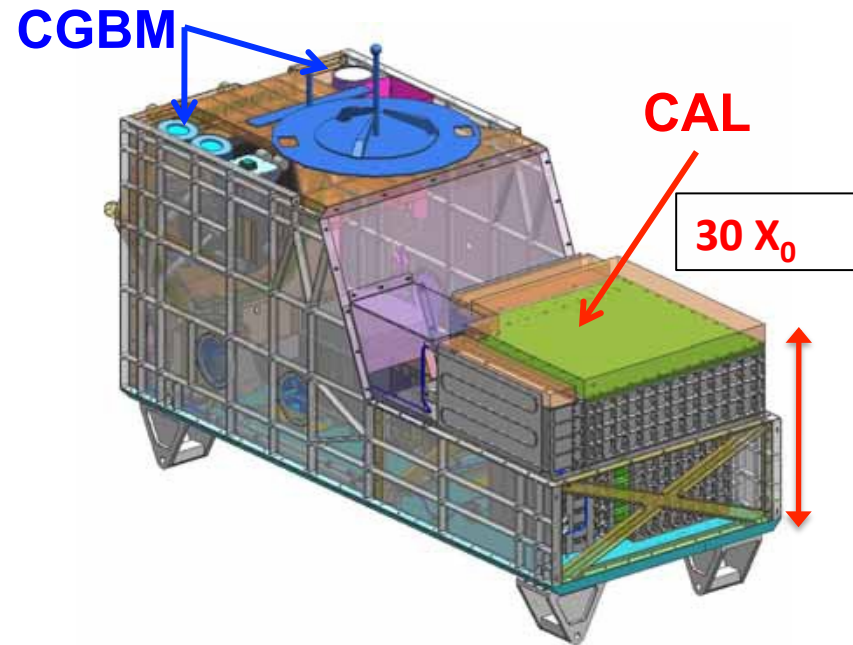

CHD: 2 x,y layers of 45 cm long scintillator paddles.  
 IMC: 16 x,y layers of scintillating fibers interleaved with tungsten plates (3 X<sub>0</sub>)  
 TASC: 12 x,y layers of lead tungstate logs (27 X<sub>0</sub>)