



# ***IHPRPT Steering Committee Meeting***

## ***NASA Spacecraft Propulsion Update***

**18 September 2013**

**Mark Klem**

**Michael Meyer**

**Robert Jankovsky**

**David Jacobson**

**NASA Glenn Research Center**

View metadata, citation and similar papers at [core.ac.uk](http://core.ac.uk)

provided by NASA Technical Reports Server  
brought to you by  
**CORE**



# NASA Spacecraft Propulsion Sponsorship

## NASA

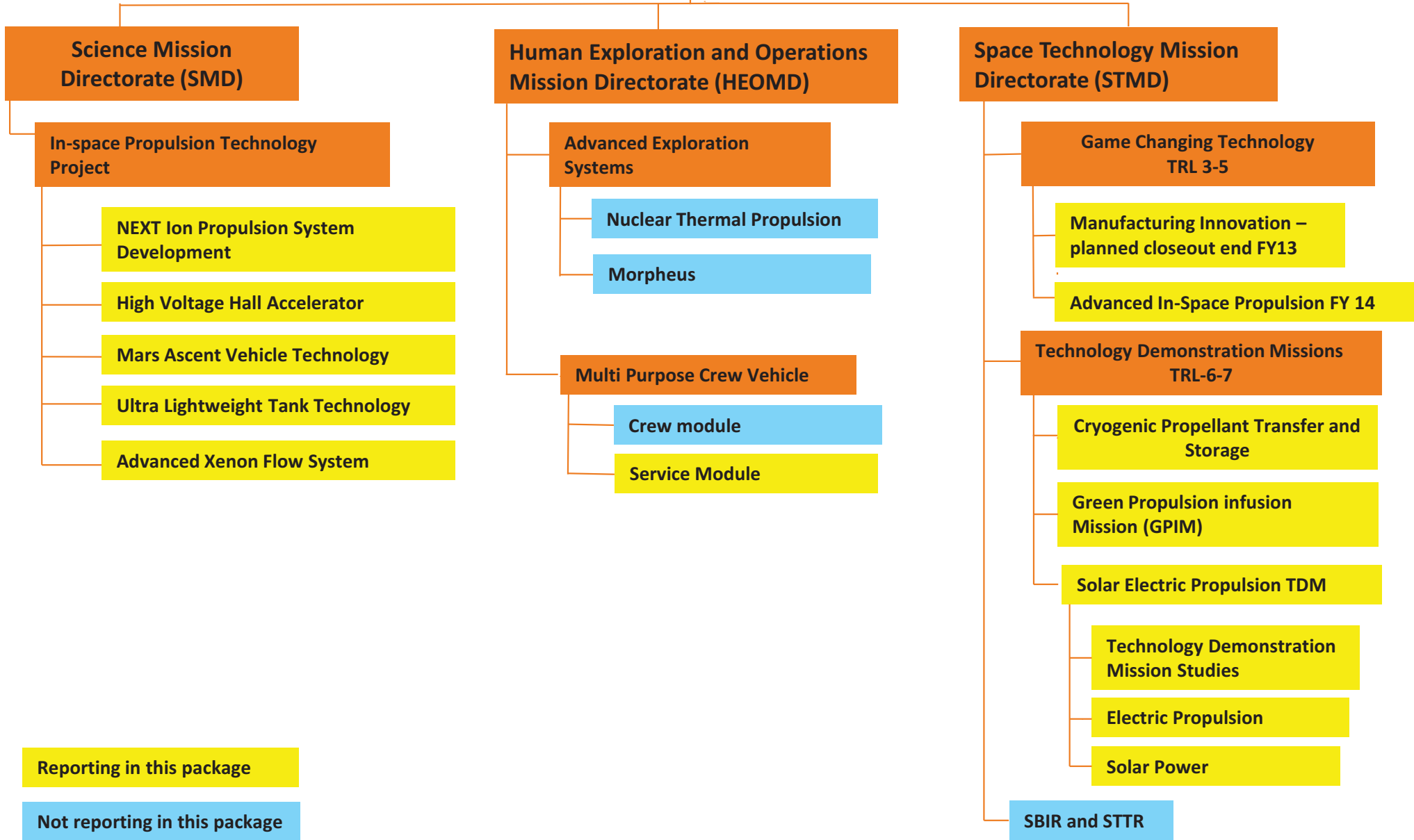



# **NASA Science Mission Directorate (SMD)**



# NEXT Ion Propulsion System

## Objective:

- Improve the performance and life of gridded ion propulsion system (thruster, power processing unit (PPU), feed system, gimbal, digital control interface unit) to enhance/enable a broad range of NASA SMD missions.

Thruster Power, kW	0.5 - 6.9
Specific Impulse, s	1400 - 4190
Max Efficiency, %	71
Thrust Range, mN	26 - 236
Propellant Throughput, kg (projected)	$870 \pm 70$

## Recent Accomplishments:

- ◆ The NEXT ion engine long duration test has accumulated >49,900 hrs of operation, processed over 896 kg of xenon, and demonstrated a total impulse of 34.7 MN-s as of September 4, 2013. This test has exceeded expectations and has set records as the longest operating electric propulsion thruster with the highest demonstrated total impulse.
- ◆ A voluntary decision was made to initiate the long duration test (LDT) shutdown process in April 2013. The test termination sequence includes a full performance characterization test, diagnostic replacement and performance validation test, and thruster removal and destructive post-test analysis.
- ◆ LDT shutdown reviews were completed on full performance characterization test results, test termination process, and facility impact assessment.
- ◆ Proposed circuit design was completed for neutralizer plume-mode detection technique developed in collaboration with The Aerospace Corporation.

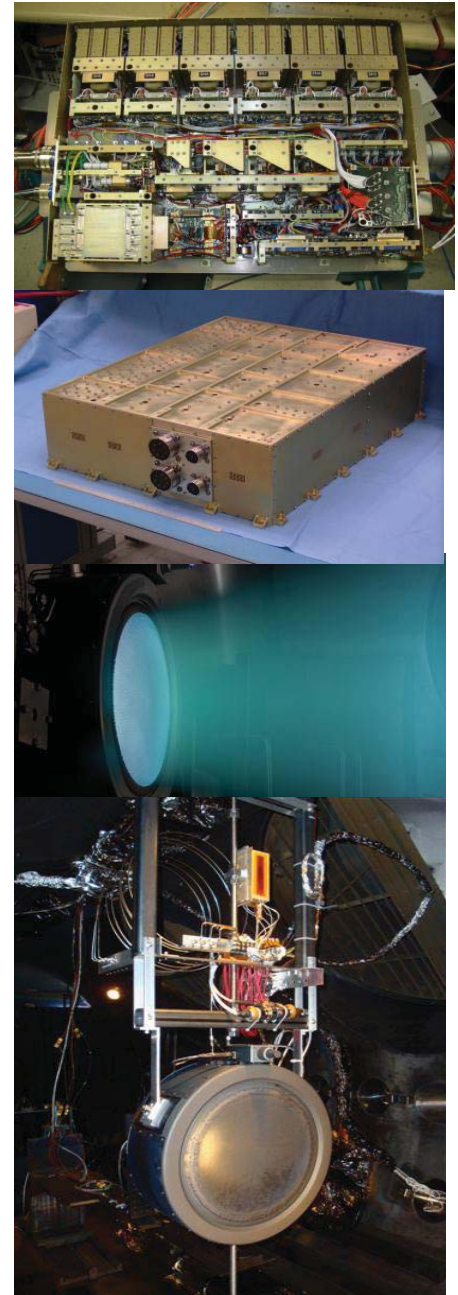

# High Voltage Hall Accelerator (HIVHAC)

## Objective:

- Develop and demonstrate a high performance, low-cost electric propulsion option for NASA Discovery-class science missions

Thruster Power, kW	0.3 – 3.9
Specific Impulse, s	860 – 2700
Max. Efficiency, %	60
Thrust Range, mN	20 – 207
Propellant Throughput, kg	> 300

## Recent Accomplishments:

- ◆ Colorado Power Electronics (SBIR contractor) delivered enhanced brassboard PPU in June 2013.
  - ◆ Enhanced brassboard PPU has form and fit of engineering development unit and includes slot for DCIU card.
  - ◆ First brassboard PPU has accumulated over 2000 hours of operation.
  - ◆ Second (enhanced) brassboard PPU has accumulated over 650 hours of operation at full power (3.9 kW) in vacuum.
- ◆ Brassboard-level system integration test was conducted in Vacuum Facility 5 with HIVHAC thruster, VACCO flow control module, and CPE brassboard PPU in April/May 2013.
  - ◆ Test utilized AFRL/Aerospace Corp/GRC diagnostic suite.
  - ◆ Thruster performance, thermal, background pressure sensitivity, and stability tests were performed.
- ◆ Thruster accelerated wear test initiation is projected for November 2013 (after facility repairs).

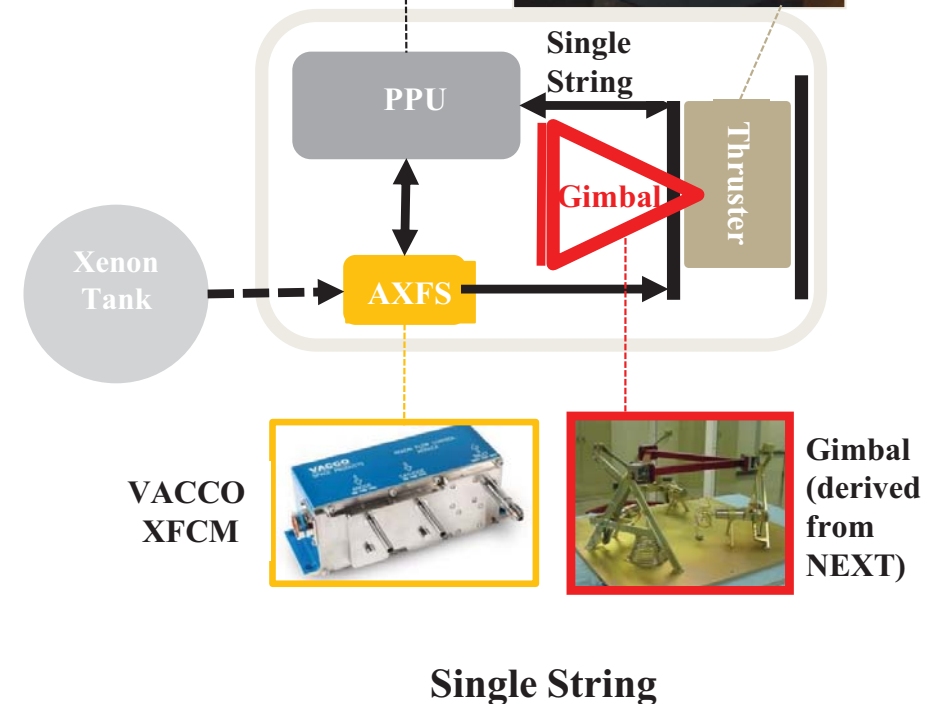
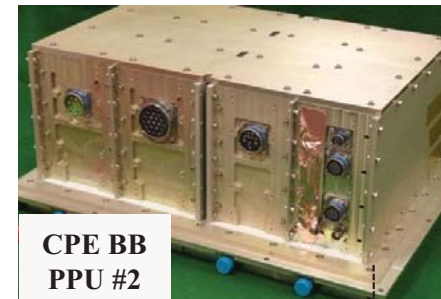



# Advanced Xenon Feed Systems (AXFS)

## Objective:

- To develop a low-cost, light-weight, low-power consumption Xenon Flow Control Module for use in Hall propulsion systems.

## Recent Accomplishments:

- NASA GRC and the AFRL are acquiring a flight-like VACCO advanced smart flow control module (SFCM) for integration with multiple hall propulsion systems.
  - SFCM design incorporates power electronics in the flow control module.
- SFCM long-lead purchases (electronics) initiated.
- Design coordination meeting for SFCM was held in April 2013.
- Hardware delivery anticipated in December 2013.

Gen 1: AXFS

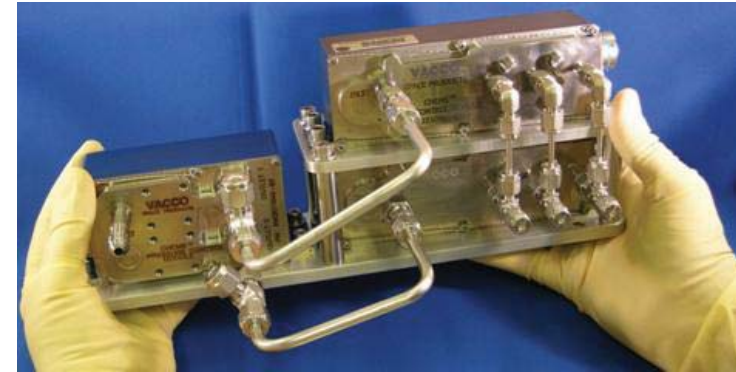

Gen 3: SFCM

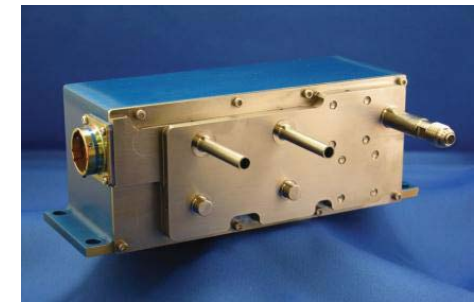

	NSTAR	NEXT	AXFS	SFCM
Mass, kg	11.4	5.0	1.5	1.7
Estimate Footprint, cm <sup>2</sup>	1,900*	1,654	800	150
# Channels Controlled	2	3	3	2
Duration to Throttle, min	45	<1	<1	<1
Average Power (Max), W		7.9(81)	<0.01	~3

\* Does not include plenum tanks

<b>Inlet Pressure Range</b>	<b>10 to 3000 psia</b>
<b>Anode Flow Range</b>	<b>20 to 202 sccm Xenon</b>
<b>Cathode Flow Range</b>	<b>3 to 20 sccm Xenon</b>
<b>Flow Accuracy</b>	<b>Cathode (<math>\pm 6\%</math> of EOL over range) Anode (<math>\pm 3\%</math> of EOL over range)</b>
<b>Internal Leakage</b>	<b><math>10 \times 10^{-3}</math> scch GHe</b>
<b>External Leakage</b>	<b><math>1.0 \times 10^{-6}</math> sccs</b>
<b>Lifetime</b>	<b>10 years, 7,300 cycles, 100% margin</b>
<b>Mass</b>	<b>1.7 kg</b>



# Lightweight Tanks for Future Planetary Missions

## Objective(s):

- Design ultra-lightweight Composite Overwrapped Pressure Vessel (COPV) tanks for future Mars Skycrane<sup>1, 2</sup> lander configuration.
- Develop and qualify Non-Destructive Inspection (NDI) technique to establish what crack size can be detected consistently (probability of detection demonstration)<sup>2</sup>

## Recent Accomplishments:

- Stress-strain characterization tests of various titanium materials have been completed in May 2013 at GRC to understand Baushinger effect on tank liner design.
- Flat forging coupons completed by ATK in May 2013.
- Eddy current verification method completed with NDI-shop in June 2013.
- Critical Design Review (CDR) is being planned on September 24, 2013, which will conclude development project.

1 - 8 kg mass savings (48% reduction) per Skycrane tank anticipated.

2 – Mars 2020 Skycrane lander is constrained to a build-to-print design.

## Descent Stage Propellant Tanks

Existing MSL Titanium Tank

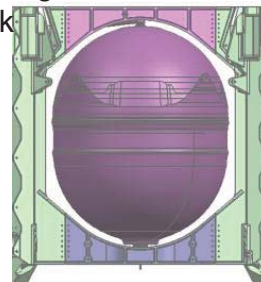

594mm Diameter,  
~720mm Tall

Drop in replacement ultralight tank

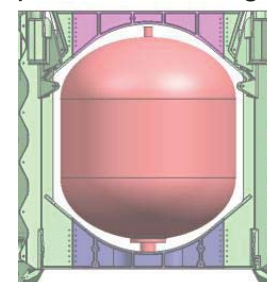

594mm Diameter,  
684mm Tall

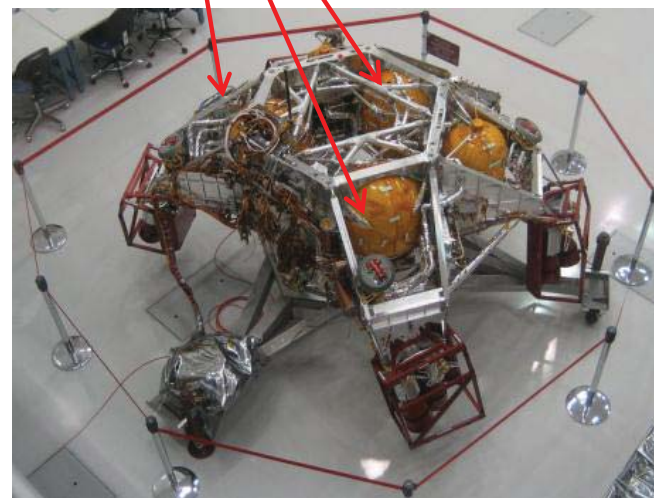



# Mars Ascent Vehicle (MAV) Propellant Testing

## • **Objective:**

- Conduct propellant aging characterization test on solid rocket propellants to understand long-term mechanical properties and performance under simulated cruise and Martian surface conditions.

## • **Approach:**

- Contract with ATK to produce HTPB (hydroxy-terminated polybutadiene) propellant samples with an option for CTPB (carboxy-terminated polybutadiene) propellant samples.
- The 18-month aging test will be conducted by MSFC at the U.S. Army Redstone Arsenal.
  - 6-month Earth-to-Mars cruise phase ( $10^{-5}$  torr,  $20^{\circ}\text{C}$ )
  - 12-month Martian surface ( $5$  torr,  $-40^{\circ}\text{C}$ )

## • **Recent Accomplishments:**

- Test Readiness Review was completed June 2013.
- HTPB propellant was shipped to MSFC August 2013.

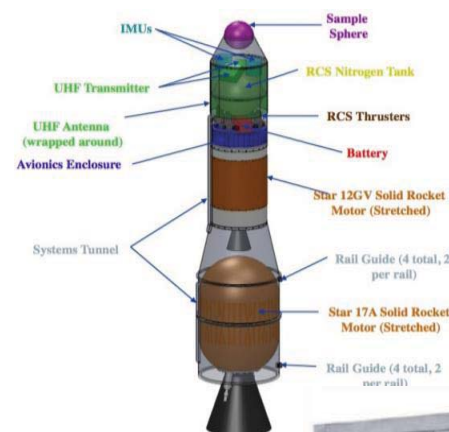





# **NASA Human Exploration and Operations Mission Directorate (HEOMD)**



# HEOMD Multi-Purpose Crew Vehicle (MPCV)

## Orion Service Module Propulsion Status

### European Service Module (ESM)

- In November 2012, NASA and ESA signed an Implementing Arrangement for ESA to provide the ESM for MPCV
- ESM provides Propulsion, ECSS storage, Thermal management, and Power generation and distribution for MPCV
- The ESA Integration Office (EIO) manages the development of the ESM and integration of the ESM with MPCV

### Design Maturation Status

- ESM SDR was completed in September 2012
- EDAC-2 (ESM Design Analysis Cycle) ran from January – June 2013
  - Focused on joint US/Europe design and planning activities
  - Independent design for PDR carried out in parallel to EDAC-2
- ESM PDR scheduled for November 2013 with subsystem PDRs scheduled before the end of the calendar year

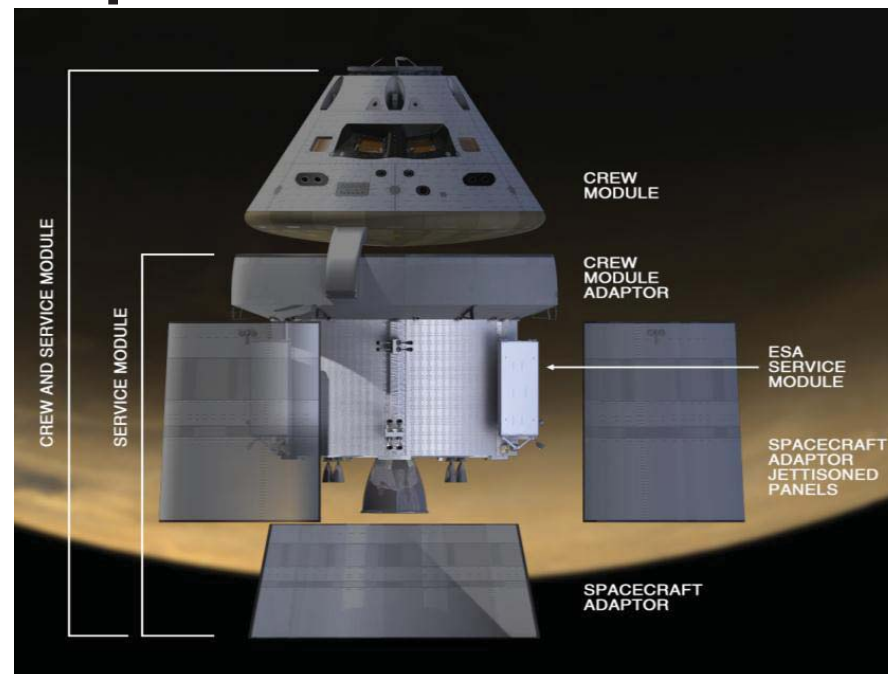

# ESM Propulsion System Configuration

Propellants: MMH / NTO

## RCS

- Two strings of 12 RCS thrusters (24 total)
- 50 lbf, 270 sec, MR 1.65, used on ATV

## Auxiliary Thrusters

- One string of 8 Auxiliary thrusters
- 110 lbf, 315 sec, MR 1.65, 300:1 R-4D-11

## Main Engine and TVC

- Shuttle OMS-E and TVC
- 6000 lbf, 315 sec, MR 1.65

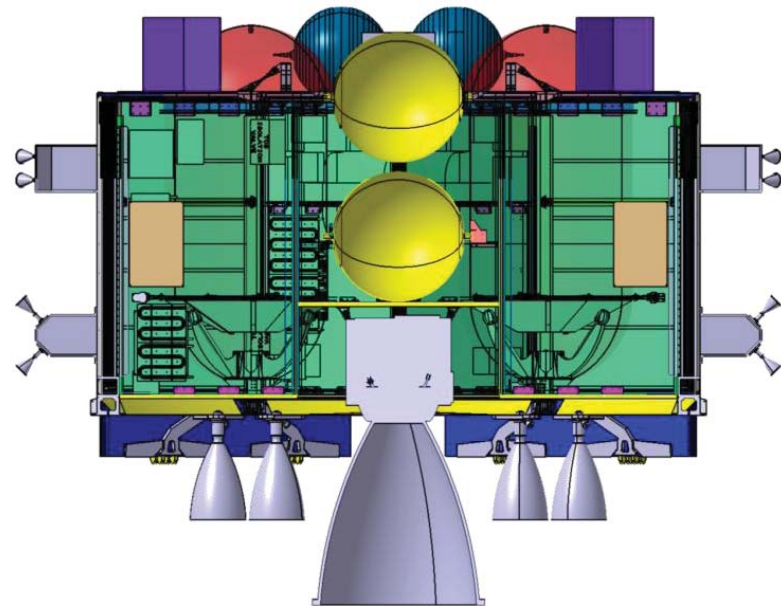

## Pressurization

- Two 6000 psi GHe storage tanks, one tank pressurizing Ox, one tank pressurizing Fuel
- Mechanical regulation

## Propellant Storage and Distribution

- 8600 kg usable propellant
- Two propellant tanks per commodity, equal volume, connected in series,
- Tank, RCS, and Auxiliary isolation



# NASA GRC Propulsion Roles

## Description/Scope:

To provide engineering support to ESA in the development of the ESM and to NASA/LM in the integration of the ESM with the MPCV. To provide the OMS-E and TVC as GFE. To procure the Aux engines for EM-1. To support integrated systems testing of the ESM at WSTF, both development and qualification.

## Government Furnished Equipment

OMS-E and OMS-E TVC, including required documentation. Available Ground Support Equipment.

## Government Funded Equipment

Procurement of Auxiliary Engines (R-4D's) for EM-1 (8 flight + 2 flight spare)

## Government Funded Testing

Integrated Systems Testing at WSTF, Development (PDM) and Qualification (PQM)

## Near Term Propulsion Engineering Support

Requirements development, bilateral document refinement

System Optimization (Mass, reliability)

Independent analyses/assessments to support system and subsystem PDR

OMS-E/TVC implementation

## Key Milestones

- 11/2013: System PDR
- 12/2013: Propulsion Subsystem PDR
- 05/2015: PDM testing at WSTF (system level development test)
- 11/2015: OMS-E for EM-1 ESM delivered to Astrium (Bremen, DE)
- 01/2016: PQM testing at WSTF (system level qualification test)
- 07/2018: OMS-E for EM-2 ESM delivered to Astrium (Bremen, DE)



# **NASA Space Technology Mission Directorate (STMD) (Formerly OCT)**



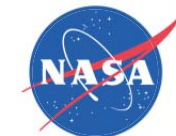

## STMD Manufacturing Innovation Project (MIP) Rocket Engine Injector Task

### Objective:

Demonstrate the ability to produce complex rocket engine components at low cost and characterize their performance in a relevant environment

### Status/ Key Milestones:

- ✓ Non-Reimbursable Space Act Agreement with Pratt & Whitney Rocketdyne (PWR) signed on May 10<sup>th</sup> 2012
  - PWR utilizing IR&D funding to manufacture low cost injectors and water cooled combustion chambers
  - NASA GRC provides igniter assembly, heat sink combustion chamber, and nozzle to mate with PWR injector
  - NASA GRC performs hot-fire demonstration in collaboration with PWR in GRC facility
- ✓ GRC support hardware design review - June 14<sup>th</sup> 2012
- ✓ PWR injector Critical Design Review (CDR) - July 18<sup>th</sup> 2012
- ✓ Single element injector cold flow characterization complete at Air Force Research Laboratory - November 2012
- ✓ Test Readiness Review - May 2013
- ✓ Hot-fire demonstration - June 2013
  - Project Close-Out Activities - in work

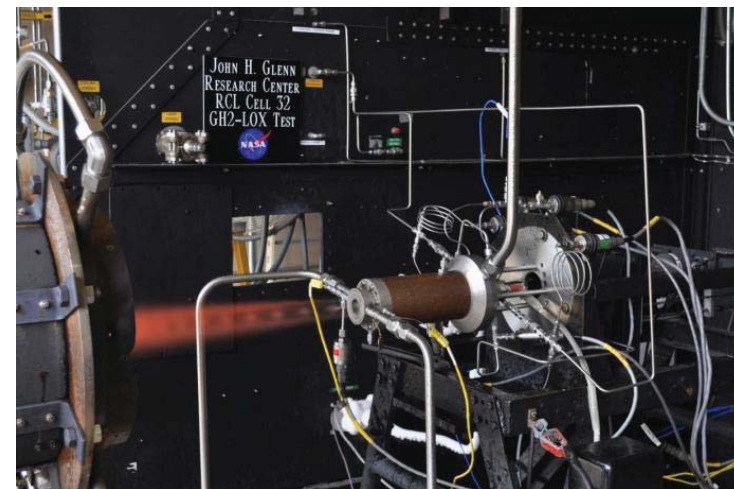

Cell 32 activation milestone completed May 2, 2013 with GRC workhorse Lox/GH2 engine tests

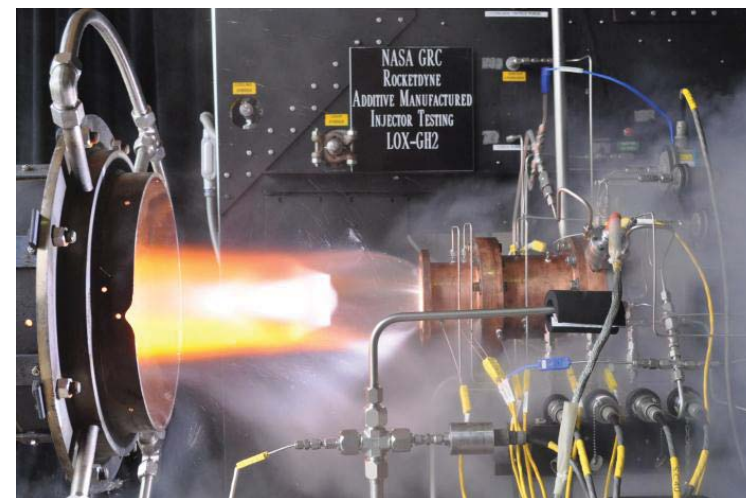

Injector hot fire demonstration June 7, 2013



# STMD Cryogenic Propellant Storage and Transfer (CPST)

## Overview

**Description:** Space flight mission to demonstrate with cryogenic propellant: passive/active cryogenic propellant storage, transfer, and gauging systems for infusion into future extended in-space missions.

**TRL Advance:** 4/5 to 6

### Benefits

Support exploration beyond LEO

- Demo long duration in-space storage of cryogenic propellants.
- Demo in-space transfer of cryogenic propellants.
- Demo in-space gauging of cryogenic propellants.

**Cost Guidance:** \$350-\$400M      **Launch:** late 2017

### Flight System Characteristics

Demonstrations	Single Fluid (LH2) Passive Storage Unsettled/settled gauging ~2 Transfer Cycles
Launch Vehicle	TBD

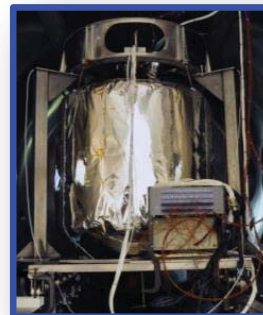

Tech Maturation test articles for LH2 reduced boil-off and advanced MLI

← Structural Testing      Thermal Testing →



### Mission Architecture Description:

#### CFM technologies include

- Passive Cryogenic Propellant Storage
- Tank Thermal & Pressure Control
- Liquid Acquisition
- Mass Gauging

**Mission Duration** – up to 2 months

#### Parallel Ground Demonstration

- Liquid Oxygen Zero Boil-off capability (Late 2013)

#### Ground Technology Maturation (to TRL ~5)

- Structural and thermal performance of passive and active cooling systems; advanced Multi-Layer Insulation (MLI)
- LAD outflow and transfer line chill down (LH2)
- Analytical Tool Development

**Team:** Lead Center: GRC

Team: MSFC, LaRC, KSC, ARC

#### Status:

- Tech Maturation completed (end of 2012).
  - Results presented to TDM 4/2013
  - Results shared in detail with industry through four workshop (Summer 2013)
- Mission reformulation trade study completed (5/2013)

#### Near Term Milestones:

- System Requirements Review: September 2013
- Project Key Decision Point B: November 2013
- Preliminary Design Review: August 2014



# STMD Solar Electric Propulsion (SEP) Project: Technology Demonstration Mission Formulation

## Accomplishments:

- Supported the NASA Asteroid Redirect Mission study.
- Completed small rideshare SEP mission study

## Forward Plans:

- Continue performing mission and vehicle studies for the NASA Asteroid mission.
- Continue performing in-house studies to understand mission/system complexity
  - Stand-alone mission based on budget
  - Mission with a partner
- Developing acquisition strategies and project schedules
- Exploring commercial partnership opportunities
- Engaging SEP stakeholders to guide formulation activities
  - Industry, Air Force, SMD, HEOMD (Waypoint, HAT), DARPA





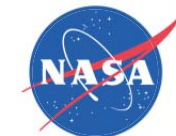

# STMD Solar Electric Propulsion: Electric Propulsion

## NASA's Goal

- Develop high power Hall thruster 12kW-class (2X current SOA) – changed from 15kW-class
- Life must be commensurate with mission.
- Pursue high voltage (i.e. 300V input) PPU/DDU system compatible with Hall Thruster

## Path Forward for Advancement

- Designing and building 12kW EDU at GRC
- The viability of using the magnetic shielding design concept to mitigate channel erosion has now been demonstrated at up to 3000-sec specific impulse and 20 kW power with JPL H6 and NASA 300M thrusters.
- Designing and building high voltage PPU (300V) EDU at GRC
- Designing and building high voltage Direct Drive (300V) EDU at GRC with test at JPL
- Integrating Thruster EDU and PPU and DDU for test by end of FY14



JPL H6 with magnetic shielding

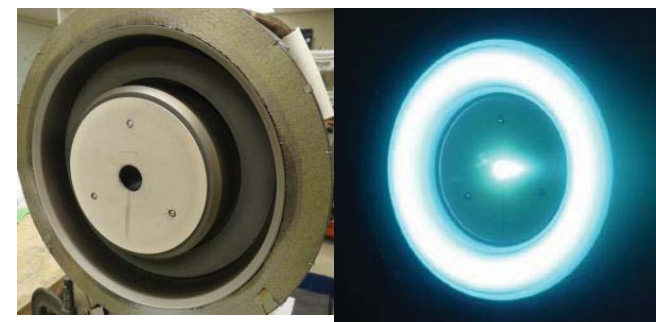

GRC 300M with magnetic shielding



Cut away of NASA 300V PPU



# STMD Solar Electric Propulsion : Solar Power

## Project Plans FY13/FY14

- **Design, build and test Engineering Demonstration Unit Solar Arrays for 30kW-class SEP**
  - MegaFlex and Mega-ROSA designs
  - Coupon plasma testing for electric thruster environment
  - Thermal-Vacuum testing planned for Spring 2014
- **Develop and use analysis models and tools to evaluate very large solar array designs**
- **Conduct destructive single-event upset tests for high voltage (300V) electronic parts (SiC transistors, diodes, bridge drivers, and gate drivers)**

## FY13 Accomplishments:

- Demonstrated reliable deployment of a 10-kW-class ROSA solar array, and conducted vacuum deployed dynamics testing on a subscale ROSA array.
- Conducted ambient deployment testing of the MegaFlex folding system pathfinder, and deployed analysis of the MegaFlex wing.
- Single event effect testing based on a spiral-out deep-space mission environment was completed on MOSFETs, diodes, and drivers; long-term thermal cycling tests were completed on several transistors.
- Conducted plasma interaction testing on high-voltage solar cell strings mounted for both MegaFlex and Mega-ROSA.

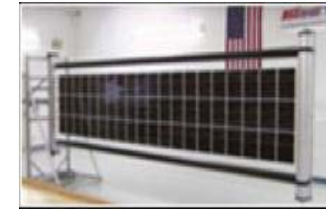

Array Development

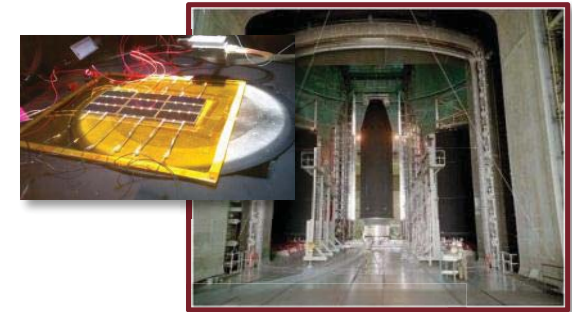
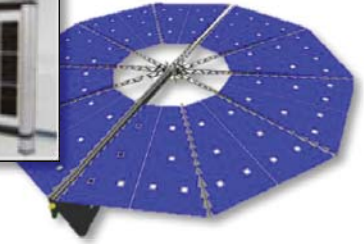

System Testing

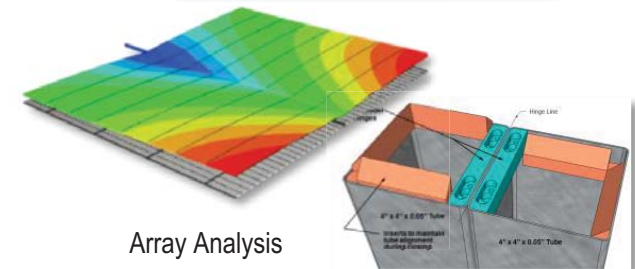

Array Analysis

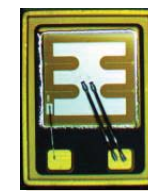

Parts Characterization

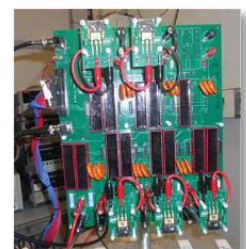





# STMD Game Changing: Advanced In-Space Propulsion

Space Technology Mission Directorate (STMD) selected three proposals for the development of miniaturized electro spray propulsion (MEP).

- 18 Month period of performance
- Start Oct 1, 2013

MEP goal areas are to perform stabilization, station keeping and pointing for CubeSats. NASA hopes these technology demonstrations may lead to similar position control systems for larger spacecraft and satellites as well.

The three awards selected:

- Microfluidic Electro spray Propulsion (MEP) - NASA JPL
- Miniature Electro Spray Thrusters Based on Porous Surface Emission - Busek Co. Inc.
- Scalable ion Electro spray Propulsion System (S-iEPS) - MIT.

Plan is for one electro spray technology to be selected for further development as an in-space flight demonstration through NASA's Small Spacecraft Technology Program.

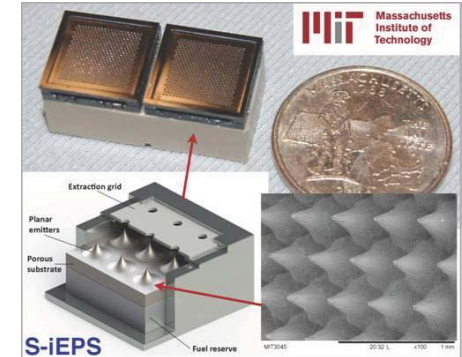

MIT - Scalable ion Electro spray Propulsion System (S-iEPS)

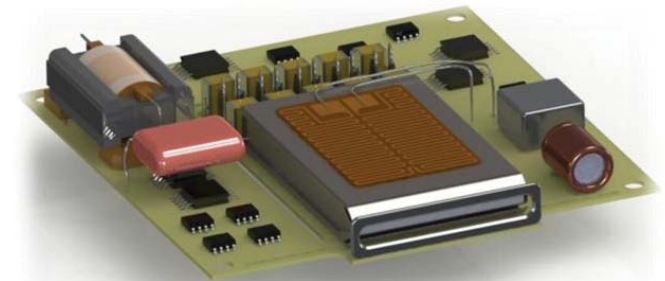

Busek - Miniature Electro spray Thrusters Based on Porous Surface Emission

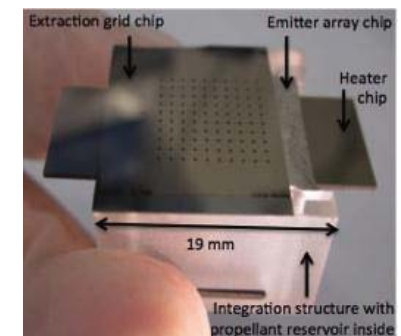

JPL - Microfluidic Electro spray Propulsion



# Green Propellant Infusion Mission (GPIM)

## NASA STMD Technology Demonstration Mission

### Objective:

In-space demonstration of a green monopropellant propulsion system with the purpose of infusing the technology into the marketplace.

### Approach/Status:

- Three-year program to develop and fly AF-M315E monopropellant propulsion system
  - Base period: Life and system level testing of 1- and 22-N thrusters
  - Option 1: Qualification of AF-M315E propulsion system for Ball Aerospace BCP-100 bus
  - Option 2: On-orbit demonstration of AF-M315E propulsion system
  - GPIM spacecraft at TRL 7+; propulsion system components at TRL 9
- GPIM team led by Ball Aerospace, with AFRL Edwards, NASA GRC, NASA KSC and Aerojet as co-investigators; mission support from USAF SMC
- Launch scheduled for September 2015



# Green Propellant Infusion Mission (GPIM) NASA STMD Technology Demonstration Mission

## NASA GRC is evaluating AF-M315E plume impingement effects:

- Modeling of 1- and 22-N thruster plumes
- Calculation of plume heating and species deposition rates on spacecraft surfaces
- Evaluation of plume impacts to solar array power generation capabilities
- Plume measurements of a 22-N thruster to collaborate data with modeling
- Provide capability to conduct plume impingement analysis for future applications
- Support AF-M315E tank fracture mechanics task w/ NASGRO analysis

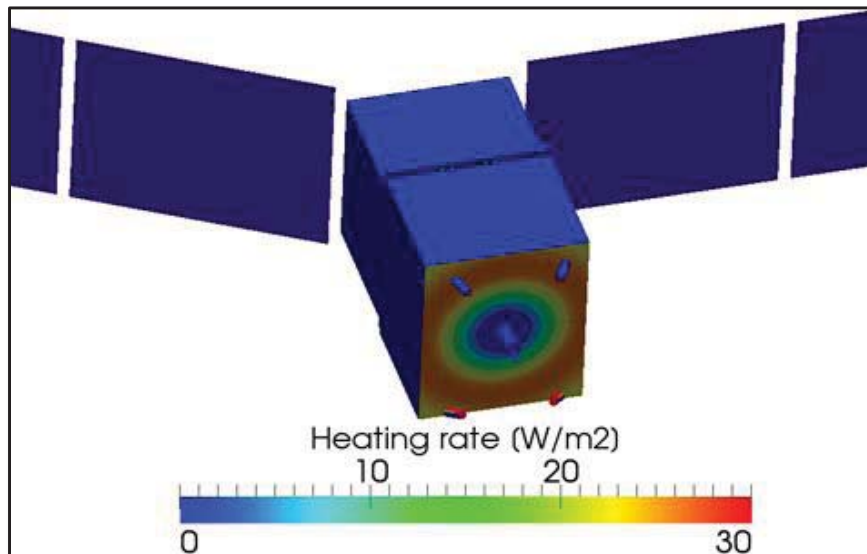

**22N Thruster Heat Flux Profile**

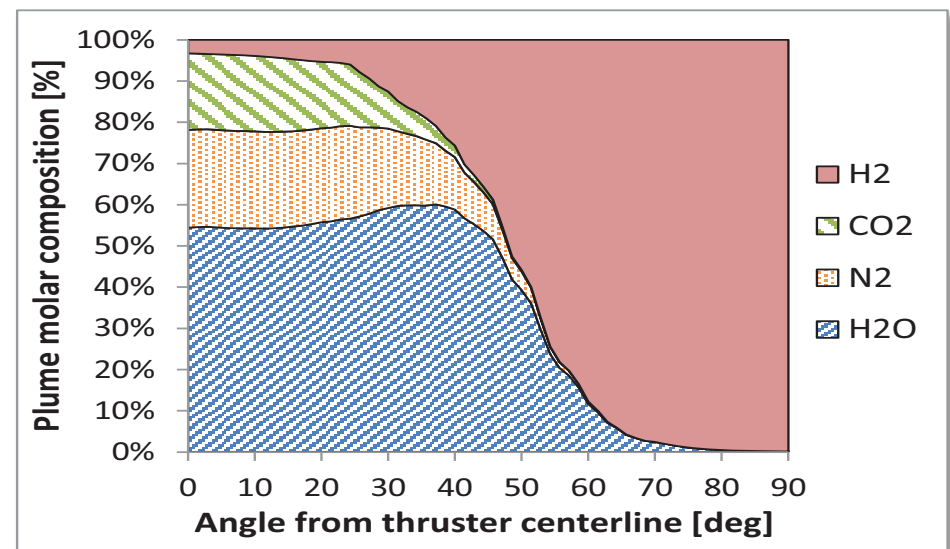

**22N Thruster Plume Species  
Azimuthal Profile**