



# mSTAR Requirements and Reference Design

mSTAR Workshop - Riyadh  
March 9, 2014

# SAUDISAT-4/UV-LED AS AN mSTAR PATHFINDER

# Comparison of UV-LED and mSTAR Requirements



Requirement	UV-LED	mSTAR	Notes
Mass	8 kg	29 kg (41 kg)	STAR Estimate (Bottoms-up Est)
Power (avg)	9 W	53 W (66 W)	STAR Estimate (Bottoms-up Est)
Power (max)	11 W	TBD	STAR Estimate
Data rate	59.6 kbps	TBD	STAR Estimate
Data volume	24 MB/day	52 MB/day	STAR Estimate
I/F Temperature	0 °C – 8 °C ±0.5 °C	+/- 0.1 K	UV-LED Performance
S/C Attitude Knowledge	10 deg	1 deg (TBR)	
S/C Position Knowledge	+/- 20 km (Position)	N/A	
S/C Velocity Knowledge	N/A	1 arcmin (~2 m/s)	

# UV-LED Components

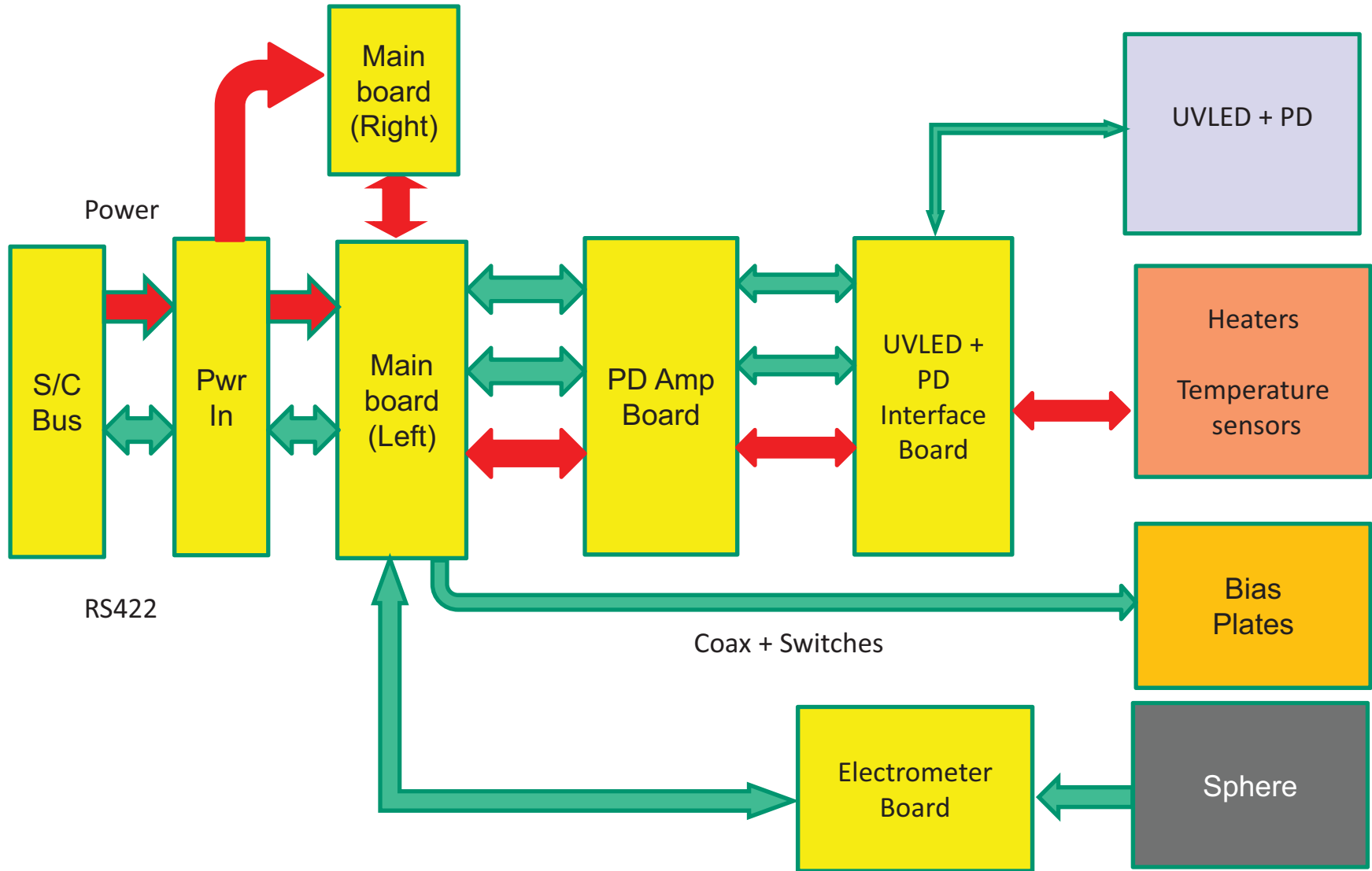

# UV-LED Available Volume

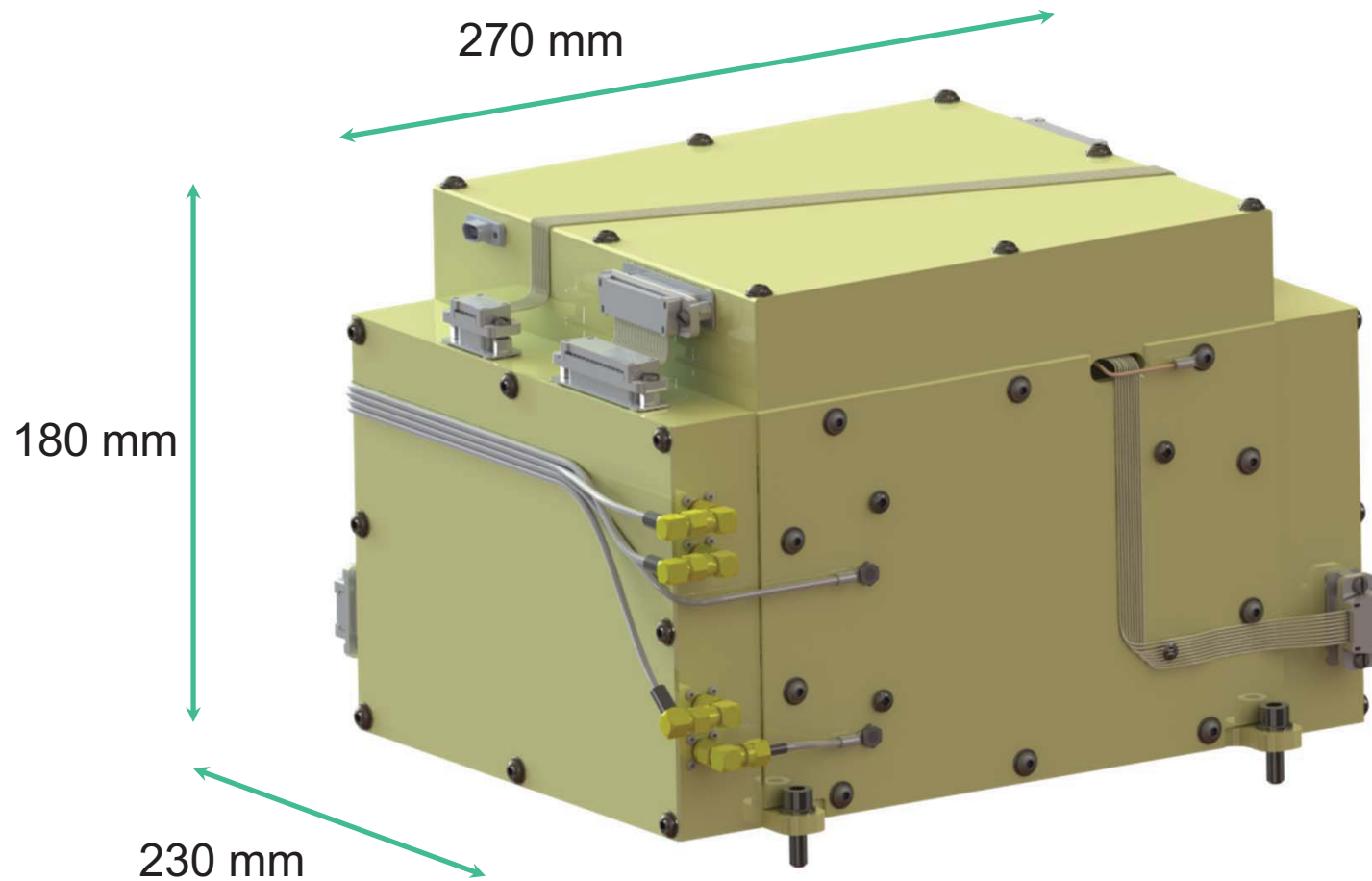

# UV-LED Interface



- **Mechanical:** Four bolts to a flat plate
- **Electrical:** One power cable, dual redundant
- **Data:** One RS-422 interface cable, dual redundant, full duplex
- **Thermal:** Control of interface plate temperature to +/- 0.5 °C
- **Control:** Time tagged command pass-through
- **Sun-safe:** No notification from s/c

# Keys to UV-LED Design



- **Simple interfaces allow independent development of payload and bus**
  - Bolted interface, RS-422 and power
- **Payload does not require real-time control from spacecraft**
  - Time tagged payload commands sent to s/c
  - S/C collects payload data and passes it to ground
- **Payload can be operated in space in the same way that it is operated on the ground**

# mSTAR MISSION DESIGN



# Mission Orbit



## Circular, sun-synchronous, 650 km orbit

Orbit Parameters	Baseline Orbit	Alt. Orbit
Mission Duration (months)	24	24
Orbit Perigee Altitude (km)	650	650
Orbit Apogee Altitude (km)	650	650
Orbit Inclination (deg)	98.01	98.01
Orbit Period (min)	97.7	97.7
Orbit Right Ascension (deg)	262.85	307.6
Orbit Velocity (km/sec)	7.5	7.5
Maximum Eclipse Duration (min)	20	31
Minimum Eclipse Duration (min)	0.5	0.2
De-orbit Lifetime (yr)	11.3	10.9

# Mission Orbit

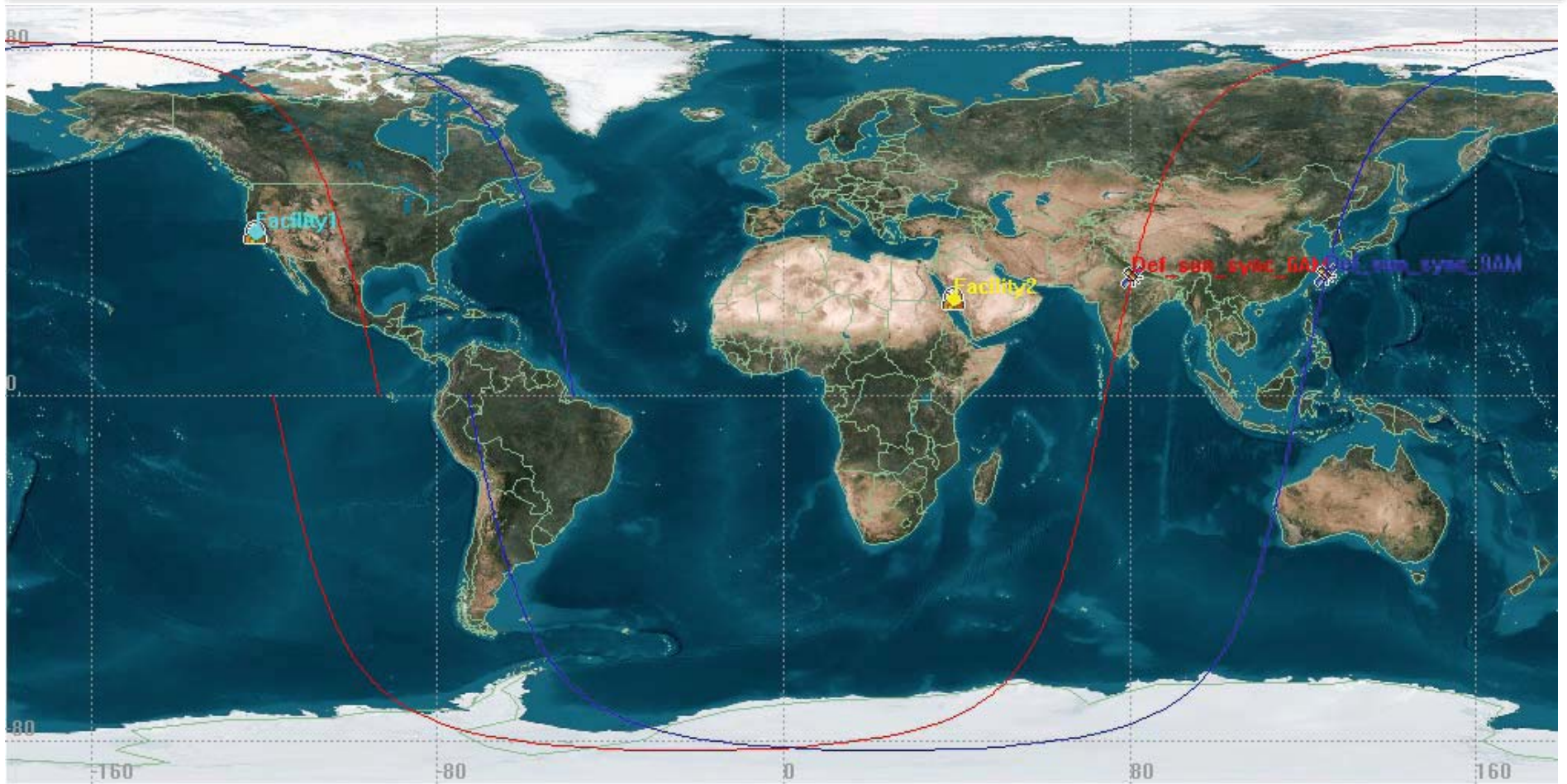

Contact Durations (assuming 15° elevation angle)

- 4 to 5 contacts per day
- 350 second average contact
- 270 second one-sigma low

## Chosen orbit will meet mission science requirements

- Low altitude
  - Sensitivity of the KT is greatest for lower orbits
  - Minimizes the need for radiation shielding and hardened components
  - Provides regular, predictable ground station contacts
  - De-orbit naturally within the 25-year limit
- Circular orbits
  - Provide sufficient difference in relative velocity effects
- Sun-synchronous
  - Maintain fixed orientation relative to Sun to enhance thermal stability
  - Ensure orbit plane passes through RA 11.2 h and 23.2 h
    - KT measurements most sensitive

# Lifetime / Re-entry and Radiation



- **Re-entry Model Parameters (based on original STAR proposal)**

- Model: NRL MSISE2000
- Mass: **180 kg**
- Drag Area: **13.65 m<sup>2</sup>**
- Area Exposed to Sun: **15.43 m<sup>2</sup>**

Orbit Parameters	Baseline Orbit (6am)	Alt. Orbit (9am)
Mission Duration (months)	24	24
De-orbit Lifetime (yr)	11.3	10.9

- **Radiation Model Parameters**

- Below the main Van Allen belts
- Some radiation from the South Atlantic Anomaly and other sources will impact spacecraft
- Will receive ~ 5 kRads
- With 2X radiation design margin, minimum hardness requirement = 10 kRads

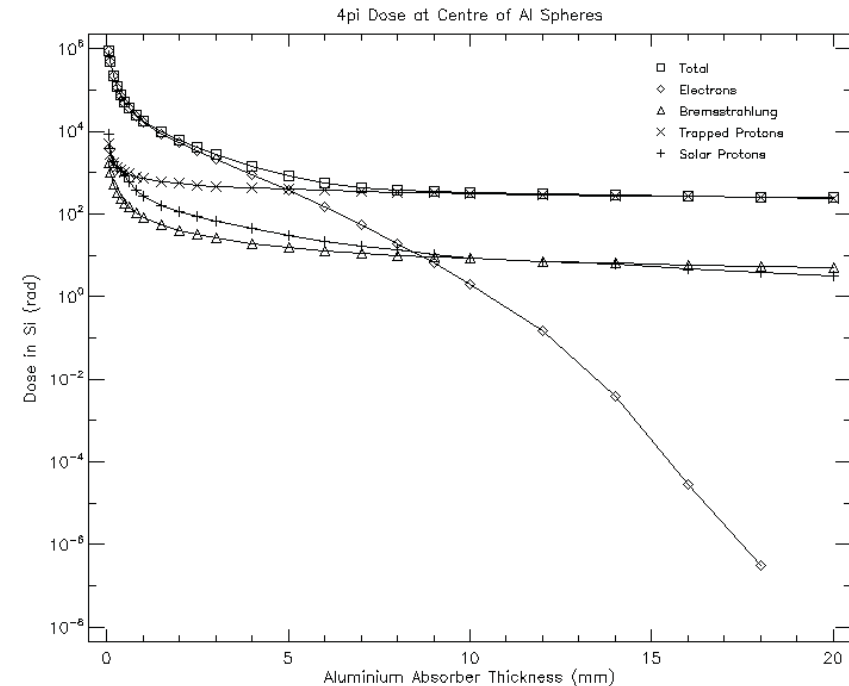

- **Current concept assumes secondary launch to 650 km, 6 AM Sun-synchronous orbit**
  - Assumes injection to circular orbit by LV upper stage
  - Eclipses will drive battery and solar array sizing
  - Current concept assumes “best” science done during non-eclipsing portions of year
    - May lead to variations in instrument performance as function of preferential reference frame orientation
- **Upcoming US launch manifest does not include this range**
  - Greater altitudes normal for SSO ( $\sim > 780$  km)
    - Would require propulsion system for de-orbit
  - Most want 9 – 11 AM orbits for illumination
    - No major change to expected power system
    - Thermal environment not optimal for best instrument performance
- **Updated information on selected launch vehicle will become driver soon**
  - Thermal design of payload
  - Loads analysis for spacecraft structures
  - Envelope and MOI requirements could drive structure and packaging



# Launch Date Considerations



- All circular, sun-synchronous orbits below 1350, have periods of eclipse
  - Average eclipse duration is 18 min
  - 1/3 of year in late fall (northern hemisphere)
- Eclipse Season
  - KT measurement most sensitive during RA: 11.2 h and 23.2 h
  - For 6am orbit - eclipsing will occur at 11.2 h (max ~ 20min)
  - For 9am orbit - continuous eclipsing at 11.2 h and 23.2 hr (max ~ 31min)
  - Enough battery power while eclipsing to take data and store it

Orbit Parameters	Baseline Orbit	Alt. Orbit
Mission Duration (months)	24	24
Orbit Altitude (km)	650	650
Maximum Eclipse Duration (min)	20	31
Minimum Eclipse Duration (min)	0.5	0.2
Eclipse Frequency	~ 8 months	Continuous

May be preferable to launch during eclipse season to allow uninterrupted primary science after checkout

# mSTAR Program Flow

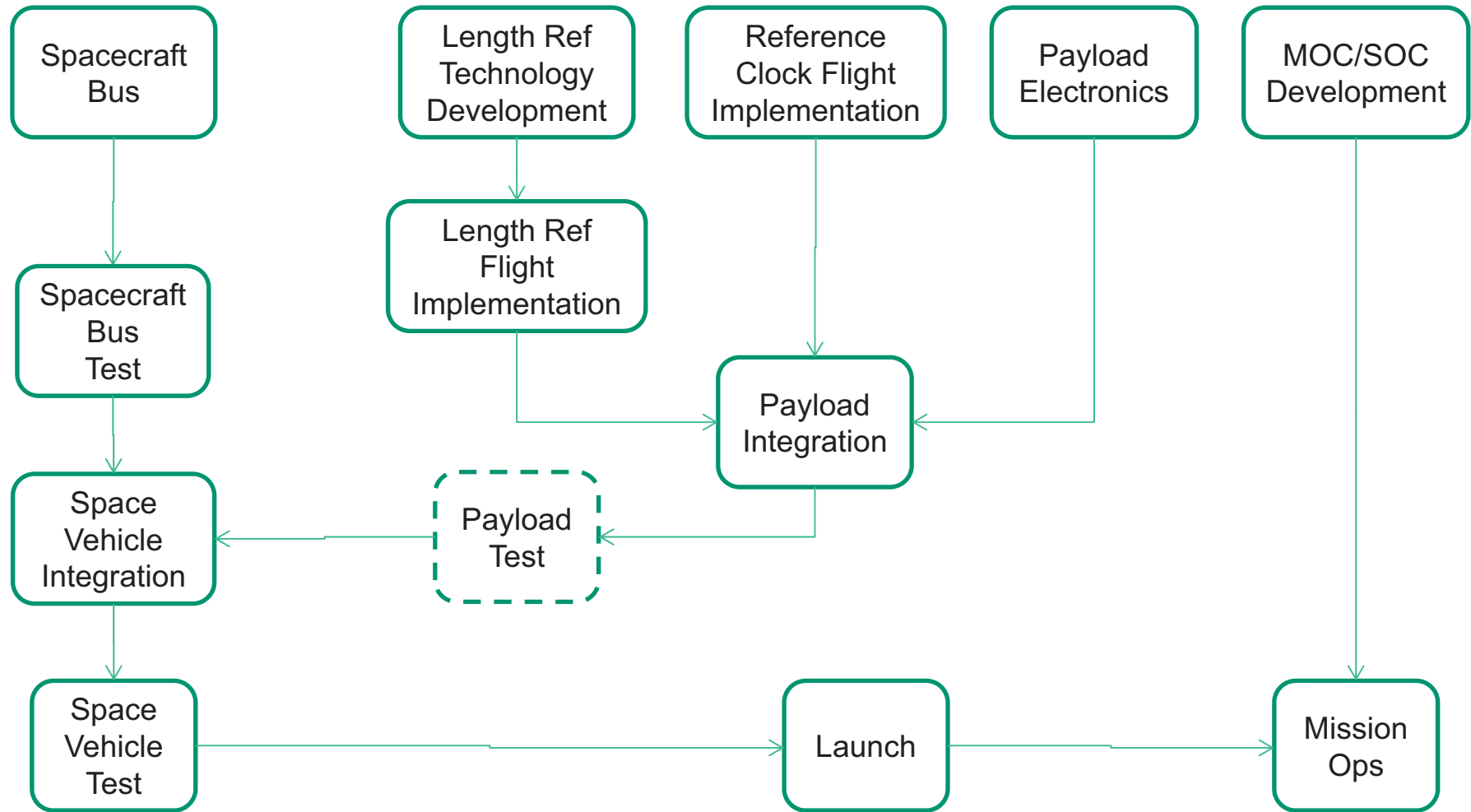

# Ops Concept

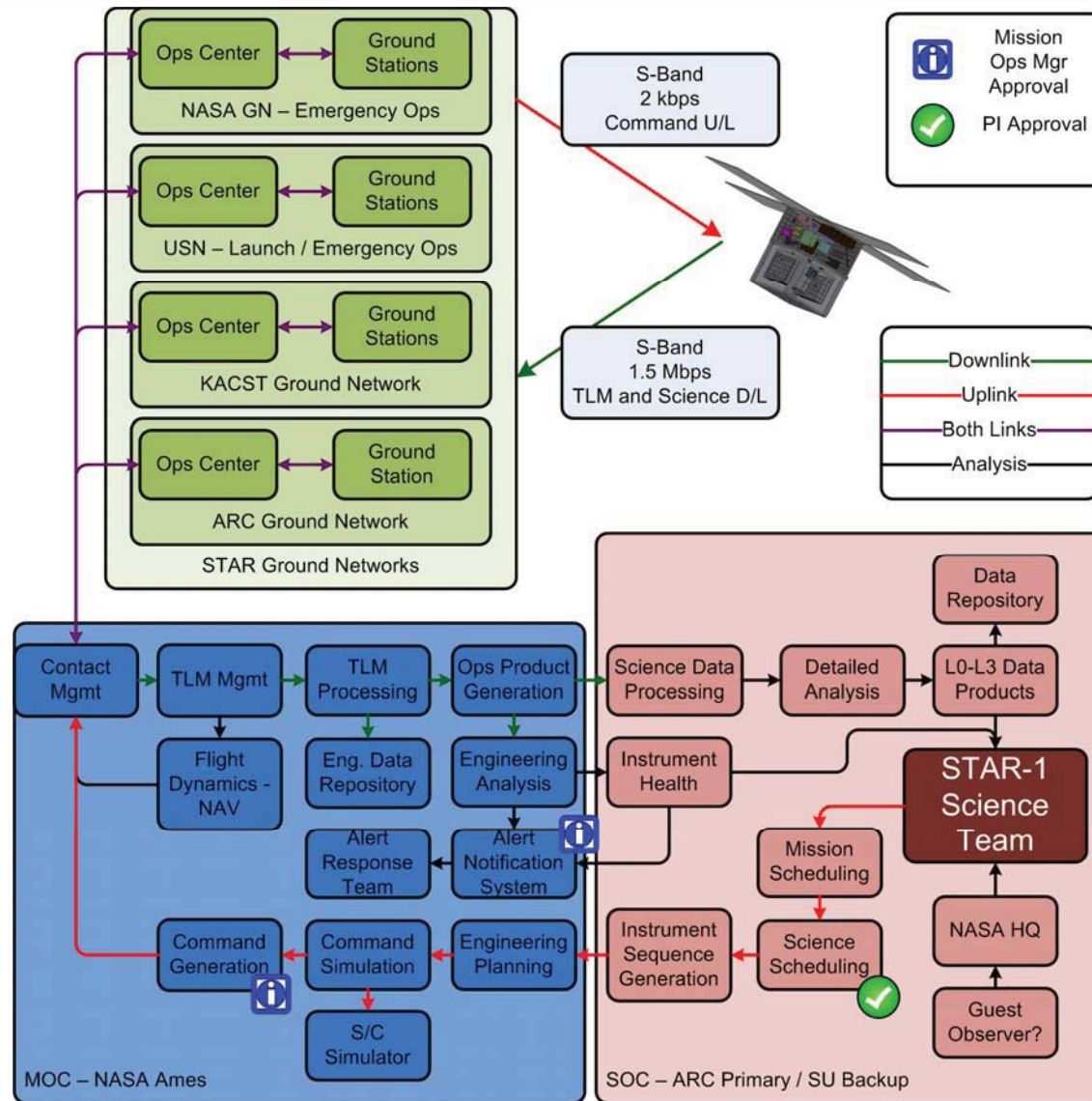



# REFERENCE SPACECRAFT BUS (STAR MISSION)

# Summary, Mass and Power Budgets

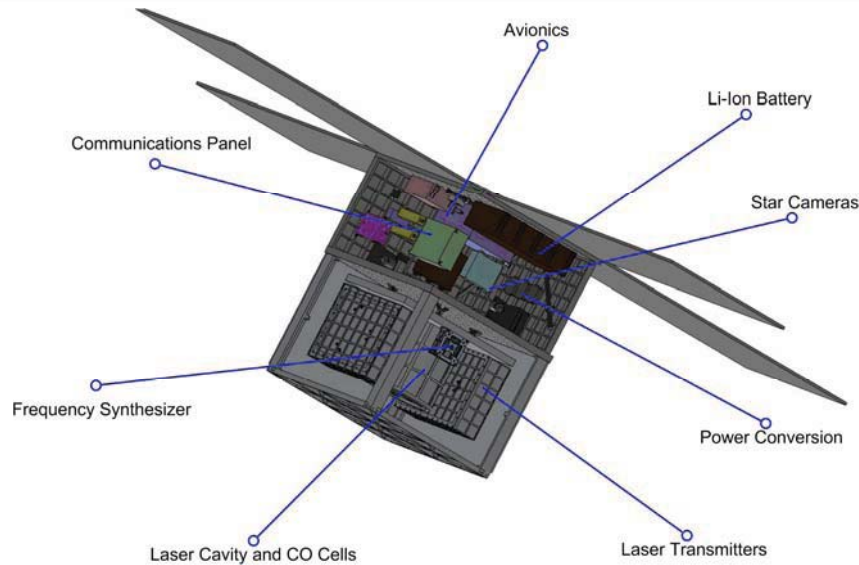

- Simple COTS components in spacecraft bus
- Spin-stabilized using only magnetic actuators
- Passive thermal control, low vibration noise
- 1.5 Mbps S-band downlink using patch antennas

Mass Budget	CBE Mass (kg)	Mass Cont. (%)	Total Mass (kg)
Payload	31.6	31.6%	41.6
ADCS	4.7	3.8%	4.9
C&DH	6.9	9.3%	7.5
Communication	5.5	8.4%	6.0
Power	34.7	20.2%	41.6
Structures	28.8	20.0%	34.6
Thermal	2.7	25.0%	3.4
LV Adaptor	3.0	3.0%	3.1
Launch Mass	117.8	21.0%	142.6
Capability			180.0
Margin		20.8%	37.4

Power Budget	OAP Power (W)	Power Cont. (%)	Total Power (W)
Payload	55.6	30.0%	72.3
ADCS	16.4	3.9%	17.0
C&DH	39.6	5.6%	41.8
Communication	8.7	3.0%	9.0
Power	14.6	20.2%	17.6
Structures	0.0	0.0%	0.0
Thermal	6.2	25.0%	7.7
Total OAP Power	141.1	17.2%	165.4
Daytime Energy (W-hr)			205.8
Eclipse Energy (W-hr)			112.2
EOL Power Req (W)			248.9
EOL Power Gen. (W)			316.0
Margin (W)		27.0%	67.1
Battery Capacity (W-hr)			672.0
Battery DoD			14.2%

# ADCS



- Design considered wheels or torquers
  - Torquers meet control requirements with less mass, cost, and vibration
  - Air coils preferred to reduce permanent dipole moment
- Sensors need to provide 20 arc-second knowledge with rotation
  - Two headed tracker provides 4.2 arc-second knowledge in all orientations

Attitude Determination and Control Subsystem

Component	Qty.	Total Mass (kg)	Power by Mode (W)		
			Daylight	Eclipse	Eclipse Telecomm
Control Actuators		1.3	3.3	3.3	3.3
Magnetic Torque Rods	3	1.3	3.3	3.3	3.3
Attitude Sensors		3.4	13.1	13.1	13.1
Coarse Sun Sensors	6	0.1	0.0	0.0	0.0
Magnetometers	1	0.1	0.9	0.9	0.9
Star Trackers	2	1.9	7.4	7.4	7.4
GPS Receivers	1	1.3	4.8	4.8	4.8
<b>Subsystem Total</b>		<b>4.7</b>	<b>16.4</b>	<b>16.4</b>	<b>16.4</b>

- Nutation damper not effective at spin rate
  - Too low to break surface tension
  - Typical dampers act as solid mass
- Magnetically damping spin nutation provides required stability

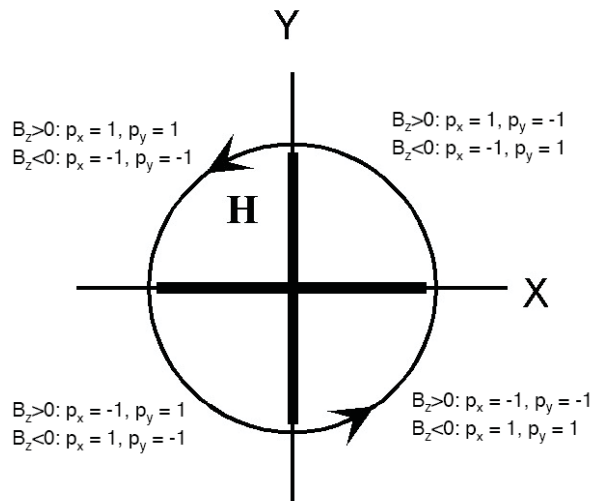

$$M = 7 \text{ Am}^2$$

$$I = \begin{bmatrix} 20 & 0 & 0 \\ 0 & 20 & 0 \\ 0 & 0 & 30 \end{bmatrix} \text{ kgm}^2$$

$$\omega_z = 0.016 \text{ rads}^{-1}$$

$$A = 0.1 \text{ A-m}^2$$

