

## **The Icebreaker Life Mission to Mars: A search for biomolecular evidence for life.**

Christopher P. McKay, Carol R. Stoker, Brian J. Glass, Arwen I. Davé, Alfonso F. Davila, Jennifer L. Heldmann, Margarita M. Marinova, Alberto G. Fairen, Richard C. Quinn

NASA Ames Research Center  
Moffett Field CA 94035  
[chris.mckay@nasa.gov](mailto:chris.mckay@nasa.gov)

Kris A. Zacny, Gale Paulsen,  
Honeybee Robotics  
Pasadena CA

Peter H. Smith  
University of Arizona  
Tucson AZ

Victor Parro  
Centro de Astrobiología  
Madrid Spain

Dale T. Andersen  
SETI Institute  
Mountain View CA

Michael H. Hecht  
JPL  
Pasadena CA

Denis Lacelle  
University of Ottawa  
Ottawa, Canada

Wayne H. Pollard  
McGill University  
Montreal Quebec

Revised 26 Oct 2012

Prepared for Astrobiology special series on Discovery Missions for Astrobiology

## **Abstract**

The search for evidence of life on Mars is the primary motivation for the exploration of that planet. The results from previous missions, and the Phoenix mission in particular, indicate that the ice-cemented ground in the north polar plains is likely to be the most recently habitable place that is currently known on Mars. The near-surface ice likely provided adequate water activity during periods of high obliquity, ~ 5 Myr ago. Carbon dioxide and nitrogen is present in the atmosphere, and nitrates may be present in the soil. Perchlorate in the soil together with iron in basaltic rock provides a possible energy source for life. Furthermore, the presence of organics must once again be considered, as the results of the Viking GCMS are now suspect given the discovery of the thermally reactive perchlorate. Ground-ice may provide a way to preserve organic molecules for extended periods of time, especially organic biomarkers. The Mars Icebreaker Life mission focuses on the following science goals: 1. Search for specific biomolecules that would be conclusive evidence of life. 2. A general search for organic molecules in the ground ice. 3. Determine the processes of ground ice formation and the role of liquid water. 4. Understand the mechanical properties of the Mars polar ice-cemented soil. 5. Assess the recent habitability of the environment with respect to required elements to support life, energy sources, and possible toxic elements. And 6. Compare the elemental composition of the northern plains with mid-latitude sites. The Icebreaker Life payload has been designed around the Phoenix spacecraft and is targeted to a site near the Phoenix landing site. However, the Icebreaker payload could be supported on other Mars landing systems. Preliminary studies of the SpaceX Dragon lander show that it could support the Icebreaker payload for a landing either at the Phoenix site or at mid-latitudes. Duplicate samples could be cached as a target for possible return by a Mars Sample Return mission. If the samples were shown to contain organic biomarkers interest in returning them to Earth would be high.

## **1. Introduction**

The motivating goal behind the Mars Exploration Program is the search for evidence of life on that planet (MEPAG 2010). Mars is the prime target for the search for life beyond the Earth primarily because of the persuasive evidence for past liquid water on the surface and indications of liquid water activity even in recent times. In addition Mars has an atmosphere that contains the essential elements, carbon and nitrogen, needed for life. Finally, the cold and dry conditions on Mars open the possibility that evidence for life may be well preserved.

Evidence for past liquid water on Mars was first discovered by orbital images from Mariner 9. Subsequent images from the Viking orbiters (e.g., Carr 1981) the Mars Observer Camera (e.g., Malin and Carr 1999), and the Mars Reconnaissance Orbiter (McEwen et al. 2007) provided images of fluvial features at ever increasing resolution indicating water flow on the surface of Mars in the past. Today there are indications of possible surface water flow on the equator-facing slopes of impact craters. Here, low-albedo features form and grow during the warmer months and disappear in the cold seasons (McEwen et al. 2011). While the source of water to form these features remains unclear, these observations indicate that under certain condition small quantities of liquid

water, possibly brines, can still form near the surface of Mars under the current climate. As explained below, the window for liquid water activity on Mars was likely wider during the last high obliquity cycle, 5 Myr ago.

The two Viking landers conducted the first, and so far only, search for life on Mars. The biology experiments sought to detect viable life based on the hypothesis that microbial life would be widely present in the soils, as it is on Earth, and that it would respond to nutrients added with liquid water. The Viking biology experiments and the pyrolysis GCMS (gas chromatograph mass spectrometer) all operated successfully on both landers (e.g., Klein 1978), but yielded negative results with respect to the presence of organic compounds or active microorganisms (e.g., Klein 2001). In brief, the post-Viking understanding of most scholars in regard to life on Mars is that 1) there was evidence for past active, stable liquid water on the surface of Mars, 2) there are no organics in the soils of Mars at the ppb level, 3) there is an active set of oxidants, and 4) there was no life present at either Viking site.

Since Viking a series of orbiters have mapped out ever more detailed morphological evidence for past liquid water and features possibly indicating present day water activity. The Gamma Ray Spectrometer on the Mars Odyssey orbiter (Feldman et al. 2004, 2008) mapped out the distribution of near surface (within a meter or so of the surface) ice showing that - consistent with predictions - ground ice was present down to latitudes of 60° in both hemispheres (Mellon and Jakosky 1999, Mellon et al. 2004). Spectral observations from orbit showed the presence of extensive unweathered basaltic rocks (Christensen et al. 2001), massive sulfate deposits (Bibring et al. 2007) and ancient clay deposits mostly associated with craters (Bibring et al. 2006). In situ studies by the MER rovers confirmed the presence of deposits associated with the action of liquid water - both morphological and mineralogical (Squyres et al. 2004, 2012).

The most recent mission to Mars, Phoenix, can be viewed as a direct follow-up in many ways to the Viking missions. Like Viking, Phoenix scooped up dirt and placed it into its instrument suite - the first mission after Viking to do so. Like Viking, Phoenix added water to the soil and also searched for organic compounds by thermal release. Phoenix landed at 68°N in a location known from the Odyssey results to contain subsurface ice (Feldman et al. 2004). Ice was indeed found as expected 5-15 cm below the surface. While the ice was expected, there were three major unexpected - and to this day still not fully explained - discoveries by Phoenix. The first was the presence of segregated ("light colored") ice in the surface materials (Mellon et al. 2009), the second was the presence of perchlorate, presumably as magnesium perchlorate, at levels of 0.5 wt% (Hecht et al. 2009), and the third was the presence of calcium carbonate at 4-5% (Boynton et al 2009). These discoveries have important implications for the search for evidence of life on Mars and are discussed in more detail below.

### **Phoenix - Ground ice.**

Numerical simulations developed based on the Viking results predicted the presence of ground ice in the polar latitudes on Mars (e.g., Farmer and Doms 1979, Fanale et al. 1986, Mellon and Jakosky 1993). These models were based on the assumption of ground

ice filling the pore spaces in the regolith and exchanging with the atmospheric moisture only by the exchange of vapor. The observations of ground ice by Mars Odyssey conformed to the predictions of these models and appeared to confirm them. However, the data also indicates that ice exists in abundances of 75–80% by volume for the Phoenix site (Feldman et al. 2008), which would exceed the pore volume of most soils. Phoenix did reveal ice-cemented ground at a depth below the surface that appeared consistent with vapor deposited ice. The mean depth was 4.6 cm and varied considerably in a way that seemed to correlate with slope and thermal inertia variations in the overlying soil (Mellon et al. 2009). However, in addition to ice-cemented soil there was relatively pure light-toned ice (Figure 1). This ice was unexpected and Mellon et al. (2009) suggest it appears most consistent with the formation of excess ice by soil ice segregation, such as would occur by thin film migration and the formation of ice lenses, needle ice, or similar ice. Many of these processes require a liquid phase – perhaps created by the presence of the strong eutectic solution of perchlorate.

[Figure 1 here]

### **Phoenix - Perchlorate.**

It had been known since the early Mars missions that there is Cl in the soil of Mars. Direct determination of Cl by Viking, Pathfinder and the MER rovers indicated about 0.5% by weight (see e.g., Clark et al. 1976, Reider et al. 2004). In addition, orbital determination of Cl abundance by the Gamma Ray Spectrometer on the Mars Odyssey mission indicated 0.2 to 0.8 % by weight over the mid latitudes ( $\pm 50^\circ$ ) on Mars (Keller et al. 2007). However, these instruments detected the element Cl and gave no information about its chemical form, which was assumed to be NaCl (e.g. Baird et al. 1976). The detection that much, if not most, of the Cl at the Phoenix landing site is in the form of perchlorate was a surprise. The detection of perchlorate was specific and somewhat accidental to the Hofmeister electrode sensor used on Phoenix (Hecht et al. 2009). The perchlorate result is robust and other possible explanations, such as nitrates, have been ruled out (Hecht et al. 2009).

Perchlorate has four independent and important implications in considerations of life on Mars; 1) organic detection, 2) freezing point depression, 3) electron donor for microorganisms, and 4) toxicity to humans. Perchlorate is the most oxidized form of the element chlorine but it is not reactive at ambient conditions on Mars. However, if heated to above  $\sim 350^\circ\text{C}$  perchlorate decomposes releasing reactive chlorine and oxygen. Thus the Viking and Phoenix thermal processing of the soils would have destroyed the very organics they were attempting to detect and thus the lack of detection of organics by Viking, and the detection of chlorinated organic species, may reflect the presence of perchlorates rather than the absence of organics (Navarro-Gonzalez et al. 2010).

Perchlorates are highly soluble salts with low eutectic temperatures. As an example, a saturated solution of  $\text{Mg}(\text{ClO}_4)_2$  has a freezing point of  $-68.6^\circ\text{C}$  – within the range of the diurnal temperature cycle of the Phoenix landing site in the summer. Due to their low freezing temperature, magnesium perchlorate eutectic solutions are thermodynamically stable for a few hours during the day at the Phoenix landing site (Chevrier et al., 2009).

Thus perchlorates may be the basis for liquid solutions even on present Mars (Renno et al. 2009, Stoker et al. 2010, Catling et al. 2010).

Perchlorates can be used in microbial metabolic pathways. It is known that microorganisms on Earth are capable of using perchlorates as electron donors (Logan 1998, Coates et al. 2000, Coates and Achenbach 2004). In principle, perchlorates could form a viable redox couple with any organic molecules or iron-rich basaltic rocks on Mars (Stoker et al. 2010). Thus perchlorates establish the possibility of chemosynthetic autotrophy on Mars.

Finally perchlorates are toxic to humans. For example the US OSHA Permissible Exposure Levels (PELs) for magnesium perchlorate (Inert or Nuisance Dust: (d) Respirable fraction) is  $5 \text{ mg/m}^3$ . Understanding the chemistry and distribution of perchlorate on Mars might become an important prerequisite before the first human mission.

### **Phoenix - Calcium Carbonate.**

Carbonates have long been searched for as a repository of carbon dioxide in the surface. A vast surface deposit could be the remnant of an ancient, thick atmosphere interacting with surface water to form carbonic acid that leads to the formation of carbonate. Evidence of  $\text{MgCO}_3$  and  $\text{FeCO}_3$  have been found in atmospheric dust (Bandfield et al. 2003) and surface rocks (Ehlmann et al. 2008, Morris et al. 2011). These carbonates likely formed due to impact processes or hydrothermal activity. Phoenix found  $\text{CaCO}_3$  in the dry soil above the ice at the 4-5% by wt, implying liquid water facilitated reactions to form carbonic acid and carbonate.

### **Recent Habitability of the Phoenix site.**

Even during the planning stages of the Phoenix mission it was appreciated that the ice-cemented areas in the northern plains of Mars were possibly the best location on Mars for recent habitability (for reasons summarized in Table 1). The presence of ice near the surface (only 4.6 cm deep at the Phoenix site) provides a source of  $\text{H}_2\text{O}$ . The atmospheric surface pressure over the northern plains is well above the triple point of water so the liquid phase even of pure water would be stable against boiling. This situation is in contrast with the ice-rich southern polar regions which are at high elevation. Note that the pressure at the Viking 2 lander site located at  $49^\circ\text{N}$  never fell below 750 Pa; the triple point of water is 610 Pa. Thus, all that would be needed to provide liquid water activity capable of supporting life is sufficient energy to melt the subsurface ice. This may have occurred as recently as 5 Myr ago when calculations indicate that Mars had an orbital tilt of  $45^\circ$ , compared to the present value of  $25^\circ$  (Figure 2). The summer insolation in the polar regions of Mars at summer solstice for an obliquity of  $45^\circ$  is about twice that for an obliquity of  $25^\circ$ . When Mars had an obliquity of  $45^\circ$ , the polar regions received roughly the same level of summer sunlight as Earth's polar regions do at the present time. The sunlight levels of 200 to  $500 \text{ W m}^{-2}$  in Figure 2 can be compared to the top-of-the-atmosphere flux at the equator on Earth,  $436 \text{ W m}^{-2}$ , and to the averaged summer solar noon flux in the Dry Valleys of Antarctica, 400 -  $500 \text{ W m}^{-2}$  (Doran et al. 2002).

[Figure 2 here] [Table 1 here]

Models suggest that the high insolation levels at the polar regions on Mars 5 Myr ago could have produced surface melting in the north. Costard et al. (2002) computed peak temperatures for different obliquities for varying surface properties and slopes. They found that, compared with the present north polar cap temperature high of about  $-60^{\circ}\text{C}$ , peak temperatures are  $>0^{\circ}\text{C}$  at the highest obliquities, and temperatures above  $-20^{\circ}\text{C}$  occur for an obliquity as low as  $35^{\circ}$  (Costard et al., 2002). They suggested this as a possible cause of the gullies observed by Malin and Edgett (2000). Richardson and Michna (2005) show that when obliquity is  $45^{\circ}$ , melting can occur 50 days per year in the high northern latitudes. The higher temperatures also enhance the hydrological cycle, evaporating water ice from the Northern Cap, which can then precipitate as snowfall in the Northern Plains.

It is well known that life can grow at subfreezing temperatures if films of water are present. Jakosky et al. (2003) discuss the potential habitability of Mars' polar regions as a function of obliquity. They conclude that temperatures of ice covered by a dust layer can become high enough ( $-20^{\circ}\text{C}$ ) that liquid brine solutions form and microbial activity is possible. Zent (2008) in a more detailed model also finds that temperatures in the shallow subsurface exceed  $-20^{\circ}\text{C}$  at high obliquity. This suggestion is all the more relevant given the presence, and antifreeze properties, of perchlorate. Rivkina et al. (2000) have shown that microorganisms can function in ice-soil mixtures at temperatures as low as  $-20^{\circ}\text{C}$ , living in the thin films of interfacial water. Such thin films have also been suggested as habitats for life on Mars (Möhlmann 2010).

Life requires a source of nitrogen. After carbon, nitrogen is arguably the most important element needed for life (Capone et al. 2006). There is nitrogen (as  $\text{N}_2$ ) in the atmosphere at low levels but this may not be adequate to support biological incorporation (Klingler et al. 1989). N in the form of nitrate is directly usable by many microorganisms and could also be a resource for human exploration both as a nutrient for plant growth and for use in chemical processes. On Earth nitrates correlate with perchlorates in desert environments and this may be also true on Mars.

In summary, the Phoenix landing site on Mars is arguably the most likely site to support recent life on Mars (Stoker et al. 2010). The near-surface ice likely provided adequate water activity during periods of high obliquity. Carbon dioxide and nitrogen is present in the atmosphere, and nitrates may be present in the soil. Perchlorate in the soil together with iron in basaltic rock provides a possible energy source. Furthermore, the presence of organics must once again be considered, as the results of the Viking GCMS are now suspect given the discovery of the thermally reactive perchlorate, and ground-ice provides an ideal substrate to preserve organic molecules for extended periods of time.

### **Searching for organic biomarkers in ground ice**

Finding evidence of organic compounds on Mars would be an important result by itself, but it would be only the first step towards establishing whether life is present on the planet, since these organics could be of non-biological origin (i.e. meteoritic). Before a

reasonable assumption of habitability can be established, it is necessary to find evidence of biomarkers. Finding mineral or morphological biomarkers would be a groundbreaking result, but would inform us little of the nature of Martian organisms. Mineral and morphological biomarkers can also represent an ambiguous sign for life, since a non-biological origin is often difficult to rule out. Only organic biomarkers carry biochemical information, and as such would provide conclusive evidence of habitability and life on Mars, and at the same time would provide information of the biological nature of Martian organisms, even if the organisms themselves were no longer present. Contrary to most near surface environments on Mars, one of the most appealing aspects of studying Martian ground ice is its potential to contain organic biomarkers and preserve them for extended periods of time.

Ground ice on Earth is efficient at preserving living cells, biological material, and organic compounds in general (Gilichinsky et al., 1992; Vorobyova et al., 1997; Vishnivetskaya et al., 2006; Johnson et al., 2007). It has been established that significant numbers of living microorganisms have been preserved under frozen conditions for thousands and sometimes millions of years (Gilichinsky et al., 1992; Vorobyova et al. 1997). Ground ice could also protect organic molecules on Mars from destruction by radiation and oxidants and, as a result, organics from biological or meteorite sources could be detectable in polar ice-rich ground at significant concentrations (Smith and McKay 2005). Radiation and photochemical oxidants are more damaging in dry regolith, where penetration and diffusion are less impeded, and therefore it is necessary to reach for deeper layers within the regolith, where organic molecules may be shielded from surface conditions.

#### **Icebreaker Life Mission goals.**

The results from previous Mars missions, particularly Phoenix, provide a strong basis for a mission that drills down into the ice-cemented ground in the northern plains and conducts a search for organic molecules and evidence of life: the Icebreaker Life mission. The Phoenix mission was able to reach the ice-cemented ground but was not able to substantially penetrate it for sampling.

To further our understanding of the habitability of the ice in the northern plains and to conduct a direct search for organics and life, the Mars Icebreaker Life mission focuses on the following science goals:

1. Search for specific biomolecules that would be conclusive evidence of life. Biomolecules may be present because the Phoenix landing site is likely to have been habitable in recent Martian history. Ground ice may protect organic molecules on Mars from destruction by oxidants and, as a result, organics from biological or meteorite sources may be detectable in polar ice-rich ground at significant concentrations.
2. A general search for organic molecules in the ground ice. If habitable conditions were present, then any organics may be of recent (<10 Myr) biological origin. Perchlorates may have prevented the Viking GCMS from detecting these organics.

3. Determine the nature of the ground ice formation and the role of liquid water. There may have been liquid water generated in the surface soils in the north polar regions within the past <10 Myr due to orbital changes in insolation. The action of liquid water would have mobilized and redistributed soluble compounds in the Martian soil. The distribution of soluble compounds can be used as an indicator of past liquid water action.
4. Understand the mechanical properties of the Mars polar ice-cemented soil. Polar ice may be a resource for human exploration and the mechanical properties will reflect the stratigraphy of ice and soil, which may inform models of climate history.
5. Assess the recent habitability of the environment with respect to required elements to support life, energy sources, and possible toxic elements. The perchlorate present at the Phoenix site could provide a useable redox couple if ferrous iron is present. A source of fixed nitrogen, such as nitrate, is required for habitability.
6. Compare the elemental composition of the northern plains with mid-latitude sites. The elemental composition for elements with atomic number greater than 11 of mid-latitude sites has suggested a uniformity in the Martian surface soil (Clark 1993, Wänke et al. 2001, Clark et al. 2005, Rieder et al. 2004). A similar measurement near the Phoenix site would allow for a direct comparison and help place the Phoenix results in the broad context of global Martian geochemistry.

## **2. Mission Implementation**

We now consider the requirements on the sampling system and measurements that must be made by the science payload to address the goals listed above.

### **Sampling**

To conduct the investigation outlined above requires that samples of ice-cemented ground be obtained from the subsurface. Observations at the Phoenix site indicated that the ice was a few to 10s of cm below the surface (Mellon et al. 2009). To ensure reaching and sufficiently penetrating the ice therefore requires a drill capability of ~ 1 meter. The Phoenix observation of white ice, possibly soft, in the upper soil surface and the variation in depth to ice-cemented ground in the area accessible by the Phoenix arm suggest that variations in the ice distribution on cm scales is possible and that a depth of 1 meter would be sufficient to sample deeply into the ice-cemented ground. Any sampling system that reaches to the ice-rich subsurface must comply with the planetary protection requirements that mandate dry heat microbial reduction and isolation for the parts of the spacecraft that reach to ice and a way to break the chain of contact between the sampling devices and the rest of the spacecraft. Thus the sample must be delivered across at least one “air gap”.

Based on the Phoenix results, the material within the first meter of the surface of Mars in the northern plains may be grouped into one of four types: loose soil, ice-cemented soil in which the pore spaces of the soil are filled with ice, solid ice, and the white ice of unknown density. A measurement requirement on the drill and sampling system is to be



able to distinguish between these four classes of materials either through the mechanics of drilling or by inspection of the samples.

The science goals for Icebreaker Life focus on the organics, biomolecules, salts, and minerals within the ice-cemented ground but not directly on the ice. Thus, it is sufficient for our purposes to collect samples in a way that the ice is lost to sublimation in the collection process. Indeed a visual measure of the volume change after sublimation of the ice component can be used as a rough indicator of ice content.

### **Organics**

One of the key goals of the Icebreaker Life Mission is to test the hypothesis that the ice-rich ground in the polar regions has significant concentrations of organics due to protection by the ice from oxidants. If this is shown to be true, the ice-rich ground will become a compelling target for future astrobiology missions (see, e.g., Stoker et al 2010).

Even absent any endogenous or biological production, organics should still be present on Mars simply due to the rain of meteoritic material which brings a flux of organic molecules estimated to be  $\sim 10^{-10}$  g cm<sup>-2</sup> yr<sup>-1</sup> (Flynn and McKay 1990, Stoker and Bullock 1997).

Moore and Schuerger (2012) and Schuerger et al. 2012) show that this rain of meteoric material will be processed by UV light to release methane and they predict a steady state residual of organics in the soil of 1-10 ppm.

In the polar regions we can consider a case in which the incoming organics are sequestered in the accumulating ice and dirt. Thus, if we knew the rate of dust and ice accumulation at high latitudes, we could estimate the concentration of organic molecules expected if the infalling organic molecules are incorporated in the ice-rich Martian soil without loss. Table 2 shows the results for a range of accumulation rates.

[Table 2 here]

As a lower limit, we can consider the mean redistribution rate of material on the surface of Mars, estimated to be  $\sim 10^{-9}$  m/yr (Golombek 1999). For this accumulation rate, the organic infall would comprise 0.1% of the surface materials if there were no loss processes. On the other extreme, Laskar et al. (2002) estimate that the rate of accumulation in the north polar layered deposits is  $\sim 5 \times 10^{-4}$  m/yr. This is a very high accumulation rate and probably only applies to the regions very near the poles. At this accumulation rate, the organic concentration for no losses would be 0.001 ppm. The optimal deposition rate for the Phoenix landing site would be such that 1 meter of drill will sample through 6 Myr of sediment. This corresponds to accumulation rate  $1.7 \times 10^{-6}$  m/yr and an organic content of 0.3 ppm.

It is important to note that our hypothesis is specific to ice-rich ground. Assuming the lack of organics at the Viking landing sites at the ppb level is valid (but cf. Navarro-Gonzalez et al. 2010), some sort of active destruction mechanism may be present – presumably reactive oxidants (e.g., Klein 1979, Zent and McKay 1994) and UV light

(Stoker and Bullock 1997, Moores and Schuerger 2012, Schuerger et al. 2012). Soil oxidants need only be present at the ppm level (McKay et al. 1998) to explain the reactivity seen by the Viking Biology Experiments. A plausible model for this oxidant is  $\text{H}_2\text{O}_2$  activated  $\text{TiO}_2$  (Quinn and Zent 1999). Bullock et al. (1994) have shown that the diffusion of atmospherically produced  $\text{H}_2\text{O}_2$  through the pore spaces of the soil could explain the lack of organics below rocks and at depths of up to 11 cm at the Viking landing sites. If the pore spaces of the soil are filled with ice, then diffusion of the atmospheric oxidant would be prevented and organics would be preserved in ice. The production of reactive chlorine due to the effect of ionizing radiation on perchlorate can also explain the Viking results (Quinn et al. 2011). Again the presence of ice may inhibit the reaction of the active chlorine species with the organics.

Note that ppm levels of organics are low for any “soil.” Even the most barren soils on Earth, from the dry valleys of Antarctica and the Atacama Desert, average more than 10 ppm organics (Navarro-Gonzalez et al. 2006) with the soils from the Atacama in Peru having the lowest values reported at 3-12 ppm (Valdivia-Silva et al. 2011). Glacial and polar plateau ice that formed ultimately from snowfall have far lower levels of organics, but this is not a good analog for ice-cemented soils because of the lack of the silicate-ice interface which creates a thin film of unfrozen water.

It is also important to note that the discovery of perchlorates at the Phoenix site may require a complete reappraisal of the non-detection of organics by the Viking missions. There have been two attempts to detect organics on Mars: the pyrolysis GCMS on Viking (Biemann et al. 1979) and the Thermal Evolved Gas Analyzer (TEGA) on Phoenix (Boynton et al. 2009). In both instances the soil sample was heated to high temperatures (300-500°C on Viking and ramped from ambient to 1000°C on TEGA). The intent was to cause the thermal breakdown of organic molecules to vaporize them, allowing detection. However we now know that this approach is flawed due to the presence of perchlorates in the soil. Navarro-Gonzalez et al. (2010) report on simulations of the Viking instrument with perchlorate added to Atacama soils and conclude that the traces of chloromethane (at 15 ppb at 200°C) detected by Viking 1 and dichloromethane (at 0.04-40 ppb at 200-500°C) detected by Viking 2 were not terrestrial contamination as postulated at the time but are the results of the reactivity of perchlorates with organics in the soil when heated. In their reanalysis of the Viking results Navarro-Gonzalez et al. (2010) suggest that ~0.1% perchlorates and 1.5-6.5 ppm organic carbon were present at the Viking landing site 1, and ~0.1% perchlorates and 0.7-2.6 ppm organic carbon were present at the Viking landing site 2. What is needed is a method that can directly detect organic molecules on Mars at the sub-ppm level in the presence of perchlorate. The Phoenix TEGA instrument has produced no unambiguous information about organics on Mars – possibly also due to the reactivity of perchlorate with any soil organics as well as with the walls of the instrument (Ming et al. 2009).

From the discussion above, we conclude that ppm detection capabilities are adequate to test our hypothesis that the ice-rich ground prevents the destruction of organics. If we do not detect organics at this level, then we have shown that the hypothesis being tested is false and that there are at best only minor enhancements of organics in the ice-rich

ground. In this case, the ice-rich polar soils will not be interesting targets for future astrobiology missions. If the ice holds a rich organic record, this would provide motivation for mission engineers to overcome the practical difficulties of landing and operating in the polar regions, and drilling through ice.

We note that there are new instruments that will be performing state-of-the-art searches for organics on Mars (Sample Analysis for Mars (SAM) on the Mars Science Laboratory (MSL,) and instruments on ExoMars). However, for these instruments the goal is to measure dry surface soil similar to that measured by Viking. Thus, instruments will advance the limit of organic detection in dry soils beyond the non-detection by the Viking GCMS or confirm the suggestion by Navarro-Gonzalez et al. (2010) that organics are present at the ppm level in these soils and were undetected by Viking. In contrast, our goal is to determine if ice-cemented ground is organic-rich on Mars as it is on Earth. If it is organic-rich, then this is of considerable astrobiological interest because of the potential recent habitability of this ice.

If the apparent lack of organics detected by the Viking GCMS was the result of thermal reaction with soil perchlorate as suggested by Navarro-Gonzalez et al. (2010) then this poses challenges for the SAM instrument on MSL. However SAM has three capabilities that should allow it to detect organics despite interference from perchlorate (Mahaffy et al. 2012). First, unlike Viking in which the analysis occurred only after thermal processing, SAM will monitor the head space gases with a mass spectrometer during the pyrolysis steps and organic fragments will be trapped at selected temperatures for GCMS analysis. Organic fragments may be detected as they react with the breakdown products of the perchlorate. Secondly, SAM has a mode in which the total organics are combusted with O<sub>2</sub> to CO<sub>2</sub> before detection. This mode should be completely independent of the presence of perchlorate which also causes oxidation to CO<sub>2</sub>. Finally, SAM has the capability for liquid extraction using derivitizing agents and this mode should not cause reactive perchlorate products to form. Thus, it is likely that the SAM instrument on MSL will be able to confirm the presence of organics at low levels in the Martian soil. This detection will further motivate the detection of organics in the ice-cemented ground in the polar regions.

The analysis above and in Table 2 has focused only on organics from infalling meteorites. If there has been recent (last 6 Myr) biological processes at the landing site, then the organic concentrations could be much higher.

### **Biomolecules**

The detection of organic molecules on Mars would be of high interest to astrobiology but it would not necessarily have any relevance to the search for evidence of life. Indeed, it is known that the Solar System is rich in organics that are not produced by biology. The search for evidence of life must target biomolecules – complex organic molecules that are only known to be produced by biological systems. Our understanding of a biomolecule is strongly influenced by terrestrial biology. However, the strategy for searching for life on Mars remains one based on the past presence of liquid water and the presence of the elements used by terrestrial life, and therefore a search for biomarkers represents a

plausible strategy. Parnell et al. (2007) have prepared a list of possible biomarkers that would be signatures of life. ATP (adenosine tri-phosphate) is an example of such biomolecule. Some are listed in Table 3. ATP is a universal component of life on Earth and its detection on Mars would be compelling evidence of life – even if no intact cells were discovered. Proteins specific to certain types of metabolism would also be suitable biomarkers. Of particular relevance in this regard is biological perchlorate reduction. It is now known that some microorganisms on Earth grow by the anaerobic reductive dissimilation of (per)chlorate into chloride. Perchlorate-reducing bacteria are phylogenetically, physiologically and morphologically diverse (Coates and Achenbach 2004), however they all share a very similar set of biomolecules that are involved in the reduction of perchlorate, and one of the specific enzymes used, perchlorate reductase, is present in all of known examples of these microorganisms (Coates and Achenbach 2004). Perchlorate reductase is one example of the many universal biomolecules that are shared by organisms across the tree of life, and which can be searched for with current technology.

[Table 3 here]

The advantage of searching for biomolecules is that their detection would be compelling evidence of life – either present or past. A further advantage is that molecular detection methods exist for these biomolecules that are extremely sensitive and specific. The disadvantage of this approach is that the specific biomolecules (e.g., ATP, perchlorate reductase) must be planned in advance and the list is effectively limited to molecules known to be biomolecules in life on Earth. This disadvantage can be mitigated by a careful selection of the target organic compounds and the large number of possible targets. A proper selection of targeted compounds can result in very high sensitivities (in the order of ppb and ppt) and the unequivocal identification of organic compounds with complex structures, or even direct evidence of biogenic molecules.

In contrast to mineral and morphological fossils, and growth-based experiments such as the Viking Labeled Release experiment, the detection of modern or relic biomolecules on Mars would not only be evidence of life but would also provide some information on the biochemistry of the putative Martian microorganisms, and possibly address deeper issues such as the nature of their genetic code, or their metabolic pathways.

### **Amino Acids**

Amino acids are a key class of possible biomarker and warrant separate discussion. As discussed at length by Bada et al. (2008) amino acids are an ideal category of organic molecules to form the basis of a search for organics because they are present in both biological and non-biological organic molecules. As the building blocks of proteins, amino acids are a type of molecule found in all biological organic material (Pace 2001). In addition amino acids are found in meteoric organic material and are produced in Miller Urey syntheses. Studies of organic rich meteorites (e.g., Botta and Bada 2002) indicate more than 70 different amino acids present. These compounds can also be readily synthesized in laboratory simulation experiments that include water (Miller 1953, Bada 2004). In living cells, amino acids (in the form of proteins) constitute nearly 75% by dry

weight of the total organic material (Bada et al. 2008). Bada et al. (2008) state that although it is not certain that an extraterrestrial biology would use the same set of amino acids as on Earth, their presence in certain types of meteorites indicates they were constituents of organic material in the early solar system and thus available for incorporation in living entities elsewhere (Sephton and Botta 2005). In addition, amino acids are robust compounds and would be expected to survive for geological time in the Martian regolith (Kanavarioti and Mancinelli 1990, Aubrey et al. 2006) and may be as resistant to oxidation by chemical oxidants as any other light organic molecule. Thus amino acids provide a key target class of molecules in a search for organics on Mars. Because biology selects a subset of the amino acids for use in proteins and these are chirally selected, the distribution and chirality of amino acids can be direct evidence for life.

### **Contamination, false positives & negatives, and null results**

Any search for evidence of life using high sensitivity and specificity requires controls to prevent contamination and false positives. This provides the proper context for understanding a positive or a null result.

Sample cross contamination is not an issue. Icebreaker's search for life is qualitative—finding evidence of life alone is mission success. Molecule concentration, or exact location in the subsurface is of less concern than a reliable detection. Hence, sample cross contamination is not an important issue for this mission.

Terrestrial contamination is the main issue that Icebreaker Life must address. Earth contaminants on the spacecraft could lead to false positives. To minimize this possibility, the payload is assembled in a cleanroom and the drill must be sterilized and protected in a biobarrier until landing. After landing, indigenous life is distinguished from contaminants by the nature of the signal (an approach implemented on Phoenix for TEGA). Contaminants would be high on initial runs and diminish with sampling. Biomarkers present in the Martian sample would not show this pattern. Control samples would be carried to Mars and would consist of organic-free blanks and blanks spiked with specific biomolecules. Organic-free blanks confirm a positive detection of indigenous life—a blank not showing the same signal indicates Martian origin. Spiked blanks confirm that lack of detection is not due to instrument failure.

False positives and false negatives are an issue with any life detection method. False positives are of limited concern because of the high specificity of immunoassays and use of controls. False negatives are difficult to prevent and could occur if we lack the right detection method for the specific biomolecules present. Thus, detection of a list of specific biomarkers provides a robust detection of life if positive, but cannot rule out life in the absence of a signal. However, we note that a null result, the lack of detection of biomarkers, is an important result. A null result establishes that Earth-like life is likely not present in the ground-ice, arguably the most habitable environment currently known on Mars, implying that Earth-like life is absent on Mars generally. This would lower the risk for biohazards during human exploration or sample return. However, this does not rule out life that does not have Earth-like biomarkers.

## **Salts and minerals**

The most surprising, and arguably the most significant, result of the Phoenix mission was the discovery of high levels of perchlorate (~0.5% by mass) in the soil overlying the ice-cemented ground (Smith et al. 2009, Hecht et al. 2009). The strong freezing point depression of perchlorate suggests that when it is present in contact with ice, liquid brines may have resulted. This could result in variations of perchlorate with depth and location (see e.g., Cull et al. 2010). Thus measurements of perchlorate concentrations over the range of 0.1% to 100% by mass may be required to understand this process.

The presence and distribution of nitrate in the martian soil and ice is of interest as well due to the importance of N to biology and N<sub>2</sub> as a major component of the atmosphere. N<sub>2</sub> is present in the martian atmosphere and nitrate is expected to be stable on Mars and to have formed in shock and electrical processes. Models for the expected concentration (e.g., Manning et al. 2009) suggest levels of 1% or so – consistent with upper limits set by the Viking data (Clark and van Hart 1982) and the Phoenix results (Hecht et al. 2009). Thus measurements of nitrate over the range of 0.1% to 5% are required to address the question of its occurrence and distribution. Sulfate is another key salt that may be mobilized by liquid brines and whose distribution may reflect past water activity. Kounaves et al. (2010) reported sulfate (SO<sub>4</sub>) in the Phoenix soil samples at levels of ~1.3(±0.5) wt%. Kounaves et al. (2010) point out that with minor exceptions (Clark et al. 2005; Ming et al. 2006), soils at previous landing sites have been reported to contain 4 to 8 wt % sulfate (Clark 1993, Wänke et al. 2001, Clark et al. 2005, Rieder et al. 2004), and have a nearly uniform S/Cl molar ratio of ~4:1. However, the Kounaves et al. (2010) results suggest a S/Cl ratio that is half of this value and they suggest that this factor of two discrepancy may be due to: (1) some of the sulfur measured by X-ray fluorescence in previous missions is in a form that is nonsoluble, or only sparingly soluble, within the time frame of the Phoenix analyses protocol; or (2) the Phoenix soil is simply different from those analyzed at other locations and sulfate or perchlorate are lower or higher, respectively, in these soils. To map out the sulfate concentration we require a measurement accuracy of 0.1% with a range up to 20%.

The question of comparing the soil of the Phoenix site to elemental analyses by previous missions (i.e. Viking, Pathfinder, and MER) is raised by both the sulfate and perchlorate results from Phoenix. To make such a comparison reliable it would be desirable to measure the soils at Phoenix using the same technique (X-ray fluorescence) that was used at Viking, Pathfinder, and the two MER sites. This is one case in which a science measurement implies a specific instrument approach. The requirement here is to measure the elemental concentrations with the same precision as was done on the previous missions, especially for sulfur. In particular, the measurement of Cl, S, Ca, K, Fe to 0.1% by mass using the APXS approach is required at the Icebreaker landing site.

## **Habitability**

To assess the habitability of the Phoenix site we must understand the availability of carbon, the activity of water, presence of an energy source, the availability of key nutrients (N, P, S), and the absence of elements in toxic concentrations (e.g., As). Carbon

is widely available on Mars in the form of atmospheric CO<sub>2</sub>, thus habitability centers on water activity, energy, and key elements.

If liquid water forms transiently at northern latitudes presently or during high obliquity, then water activity becomes a relevant factor to assess habitability (see review in Beaty et al. 2006). There appears to be a sharp limit for life on Earth as a function of water activity, with no growth recorded below a water activity of ~0.6 (Beaty et al. 2006 and references therein). The activity of pure liquid water ( $a_w$ ) at any temperature is unity and is not temperature dependent. The  $a_w$  of ice is equal to the water vapor pressure of ice divided by the water pressure over pure liquid water. Thus, the  $a_w$  of ice is temperature dependent and declines from unity as temperature decreases. At T=0°C, the  $a_w$  of ice =1.0; at T=-20°C,  $a_w$ =0.82; at T=-40°C,  $a_w$ =0.67; and so forth (Beaty et al. 2006). If ice-cemented ground at the Phoenix site was raised to temperatures warmer than -20°C then the resultant water activity ( $a_w$ =0.82) should allow for microbial activity in the thin films of unfrozen water that form on the boundary between soil grains and ice for temperatures above -20°C (Ostroumov and Siegert 1996, Rivkina et al. 2000).

While sunlight is a powerful energy source for life, it is unlikely to be biologically useful on present Mars because it requires life to be at the surface exposed to the extremely biocidal solar UV and to dry conditions. Microbial life in porous rocks or soil may be shielded from UV while allowing visible light to enter as suggested by Pollack and Sagan 1967 (see also Cockell et al. 2002, McKay 2012) but would still be subject to extreme dry conditions. Instead, subsurface chemoautotrophy is a valid alternative for Martian life. For example, perchlorate and nitrate could form the oxidizing partner in a redox couple if suitable reduced material were available. Ferrous iron from basaltic rocks would be a suitable material, as observed in anoxic environments on Earth, where microbial iron oxidation has been demonstrated to be coupled to the reduction of nitrate, perchlorate and chlorate (eg Straub et al. 1996, Weber et al. 2006). As mentioned above perchlorate is present in the Martian soil and nitrate is probably present as well. The surface of Mars is also covered with unweathered, iron-rich basaltic rocks (Christensen et al. 2001) and mechanical weathering and commutation would produce small sized particles of unweathered basaltic rocks in the soil. In Gusev Crater the MER rover detected olivine rich (ferrous iron containing) basaltic rocks (Christensen et al. 2004, McSween et al. 2009). However, Quinn et al. (2011) placed an upper limit on the levels of readily soluble ferrous iron (salts) in the soil of 1 ppm at the Phoenix site. However, microorganisms can access forms of ferrous iron that are not readily soluble so the possibility remains open (Nixon et al. in press). Given the potential for liquid water today and during high obliquity, microbial iron-oxidation coupled to perchlorate or nitrate reduction is possible. For that reason Icebreaker Life will study the concentration and distribution of ferrous iron, nitrate and perchlorate as a biologically useful redox couple on Mars in the ground ice.

The search for nitrate in the soil is also a key goal for habitability as a source of nitrogen. As discussed above nitrogen is a key requirement for life and currently there is no data on its availability. It is possible that the Mars Science Laboratory will provide the first

useful detection of nitrates in the soil by detecting the release of NO from heated soil samples.

### **Surface geomorphology**

Imaging of the terrain at the landing site and specific imaging of the sampling site provides important context information. The Phoenix landing site showed patterned ground with differences in ice depth between the polygon center and the troughs surrounding them (Mellon et al. 2009b). It is important to know which part of the polygonal distribution the drill is accessing because the polygon morphology is set by the depth to ice. Surface imaging is thus important to estimate ice depth and also to understand any surface conditions that may affect mission operations and drill placement.

### **3. The Icebreaker Life payload**

Extending the capability of the Phoenix spacecraft, Icebreaker carries a drill and a selected set of instruments. The drill penetrates into the subsurface and cuttings from the ice-cemented ground are provided as samples to the science payload. A derivative of the Wet Chemistry Laboratory determines the solution chemistry, an immunoassay microchip searches for organics and biomolecules, and an Alpha Proton X-Ray Spectrometer identifies elemental composition. A surface Stereo Camera provides context images. If space, mass, and cost allow, a laser desorption mass spectrometer provides a second detection of organics.

[Figure 3 here]

Icebreaker's configuration with drill, sample transfer system, and science instruments is shown in Figure 3 mounted on the Phoenix platform. A summary of payload characteristics and specifications is given in Table 4.

[Table 4 here]

### **The Icebreaker Drill**

The Icebreaker drill is a rotary-percussive (both rotating and hammering) drill based on several generations of drills (Zacny et al. 2012) capable of autonomous drilling and fault recovery (Glass et al. 2008) developed in the last decade (Figure 4). The drill is composed of three elements:

[Figure 4 here]

1.-Rotary Percussive Drill Head: Tests in Mars analog environments show that rotary-percussive drills are more efficient than conventional drills, particularly at the low downward force (typically 100 N) possible in Martian gravity with the spacecraft mass (Zacny et al. 2008; Zacny and Cooper, 2006).

2.-Sampling Auger: The drill must be simple and automated to lower risks and ensure proper drill function on Mars (Glass et al. 2008). This justifies using a single string with



no attachment/detachment stages, and collecting cuttings instead of coring to reduce complexity, risk, cost, and jamming potential. Icebreaker must drill cold and dry, using mechanical means, i.e. auguring, for cuttings removal and to preventing melting of ice which might refreeze and lock the drill. The sampling auger consists of a single, 1.2 m long, 25 mm diameter, deep flute auger that penetrates up to 1 m below the surface and collects drill cuttings. The extra 20 cm length of the auger is required to account for the auger tube and the brush assembly. In order for the tip of the bit to be brushed off by the auger, the auger has to clear the top of the auger tube and be in-line with the brush, i.e. approximately 20 cm above the ground surface.

3.-Drill Bit: The drill bit is intermediate between an ice-bit (sharp cutters at positive cutting angle for ice or icy-soils), and a hard rock bit (rounded cutters at zero cutting angle, for hard rocks) and designed to work with percussive system. The drill bit has an integrated thermal sensor to measure the bit temperature and the temperature of a sample. The bit temperature is also fed directly into a drilling algorithm. If a temperature exceeds certain value, the drilling either stops or slows down to let the surrounding formation cool down to prevent melting.

Prior to launch, the drill will be stowed in horizontal position on top of the lander deck. After landing, the ground surface below the drill will be photographed and analyzed for rocks and surface features. Upon the drill health check out, the three degree of freedom arm (3 DOF) will deploy the drill and lower it to the ground. The arm will then preload the drill structure against the ground with ~200 N force, which is “not to exceed” force. The drilling will commence with the hole starting routine: high rotation at low Weight on Bit (WOB). Upon reaching 2.5 cm depth, the normal drilling operation and sampling will commence. During the drilling operation, the WOB will be software limited to 100 N.

The Icebreaker drill produces cuttings that are then sampled at specified depth intervals, notionally 5 cm. After drilling the first interval the drill is pulled out and sample collected for analysis. The drill is then lowered into the hole to acquire another sample at a greater depth. This procedure can be repeated until a depth of 1 m is reached.

The IceBreaker drill was tested to 1 m depth in a vacuum chamber at Mars atmospheric pressure and in various formations ranging from ice, icy-soils, icy-soils with rocks, and rocks (Zacny et al. 2012a and b, Paulsen et al. 2011). The average penetration rate in these formations was 1 m/hr while the average power was 100 Watt and the WOB was limited to less than 100 N. The drill was also tested in the Antarctic Dry Valleys: the Mars analog site. The drill reached 1 m depth in ice cemented ground in approximately 1 hour with 100 Watt of power and less than 100 N WOB. The drill was also tested in Dry Valleys in massive ice where it penetrated to 2.5 m depth in approximately 2.5 hours with 100 Watt power and less than 100 N WOB. In all cases, the drill provided samples in terms of drill cuttings in 10 cm intervals. In the case of ice drilling, although most of the ice was pulverized by the drilling process, a single ice crystals as large as 8 mm in size were frequently observed. Hence, the rotary-percussive drilling approach not necessarily pulverizes all the ice in its way.

### **Sample Delivery System**

The Icebreaker Sample Delivery System, shown schematically in Figure 5 (from Davé et al. 2012), has three functional requirements: 1) Collect the samples from the drill consistent with planetary protection constraints; 2) Deliver samples to analytical instruments; 3) Operate with soils ranging from sandy to sticky – as both types have been seen by the Viking and Phoenix missions (Davé et al. 2012).

[Figure 5 here]

In order to comply with Planetary Protection requirements the sample delivery system collects the sample from the drill without contacting the drill hardware. This “air gap” implies that the sample delivery system need not be sterilized or contained in a biobarrier during flight, since the break in the chain of contact prevents the sampling system from transferring any contamination from the lander deck to the drill.

The key part of the sample delivery system is the unit that obtains the sample from the drill. Material collected on the drill flutes is removed by a brush as the drill rotates (Figure 5). This material is caught by the sample catcher. The shape of the catcher ensures that loose sandy and sticky material are both collected. (Davé et al. 2012).

Once the sample is in place the arm moves the sample catcher to the upper deck and prepares to deliver the sample to the instruments.

The sample delivery system moves the sample catcher into position over the intended instrument. The sample catcher then rotates and the sample is deposited into the funnel of the instrument. As the catcher rotates, the interior is swiped by a fixed vane that removes any sticky material (Figure 5). (Davé et al. 2012). No additional processing of samples is required before delivery to the instruments and one delivery is enough to satisfy instrument requirements (Davé et al. 2012).

The shaft of the sample delivery system is a hollow tube into which two aliquots of sterile control material have been inserted. On command one such aliquot can be dropped into the sample catcher for delivery to the science instruments (Davé et al. 2012).

### **Life detection instrument**

The Signs of Life Detector (SOLID) instrument (Figure 6) meets the mission objective to search for evidence of life. SOLID can detect whole cells, complex organic molecules, and simple polymers of possible biogenic origin. SOLID can detect cells and molecules at concentrations of  $10^3$ - $10^4$  cells/ml and 1-2 ng/ml, respectively (Fernández-Calvo et al. 2006, Parro et al. 2005, 2007, 2011), using the latest generation lab-on-a-chip technology to detect organic molecules via immunoassays. Using a single life-detection chip (LDCHIP) measuring a few square centimeters, SOLID’s antibody library can detect up to 300 different organic molecules. SOLID is divided into two units (Figure 6). The sample preparation unit (SPU) receives samples from the sample handling mechanism and processes them in three steps—extraction with buffer, sonication, and filtering. After filtering, the sample is transferred to the sample analysis unit (SAU). The SAU holds 16

LDCHIPs, and performs sandwich immunoassay. The presence of biomolecules and organics is revealed by fluorescent signals from binding antibodies. The fluorescent antibodies are excited by a laser beam. Fluorescence is captured and imaged by a CCD camera. Data products are images showing bright spots where fluorescence occurred. Between samples, the SPU pipes and valves are rinsed with buffer solution to minimize contamination and obstruction. Control measurements are done by running measurements in the absence of a sample (only the extraction buffer and the library of antibodies), and provide a background fluorescence signal as a baseline for the sample. Tests by de Diego-Castilla et al. (2011) have demonstrated the robustness of antibodies under extreme and space conditions and the operation of SOLID has been demonstrated at high perchlorate levels (Parro et al. 2011).

[Figure 6 here]

### **Generic organic detection instrument**

A promising candidate for organic detection on a Discovery class mission to Mars is laser desorption mass spectrometry. In this method a pulse from a laser is used to remove organic materials from the sample and they are then swept into a time-of-flight mass spectrometer. The laser pulse should cause the volatilization of organics without creating high temperature and density conditions that allow the perchlorate to react with the organics. Preliminary tests on Atacama soils with 10-100 ppm of organics with and without 1% magnesium perchlorate added confirm that this method can detect organics even in the presence of perchlorate.

### **Chemical analysis instrument**

The Wet Chemistry Laboratory (WCL) is a powerful analytical instrument that characterizes the pH, eH, and dissolved ions in the ice-cemented ground. WCL has strong flight heritage (TRL 9) from the Phoenix payload. Icebreaker uses copies of the Phoenix WCL because it meets the requirements to measure the soluble ions  $\text{ClO}_4^-$ ,  $\text{NO}_3^-$ , and  $\text{SO}_4^{2-}$  to a resolution of 0.1% by mass. WCL measures reduced iron as a possible electron donor for microbial metabolism. The presence of soluble ions in the subsurface and their distribution with depth is a key measurement for understanding the origin and possible melting of the ice. Variations in soluble ion concentration with depth suggests aqueous processes have moved the salts and segregation with depth can reflect differing solubility and differing deliquescence.

[Figure 7 here]

### **Elemental Analysis Instrument**

The goal of the elemental analysis instrument is to provide a measurement of the soils at the Phoenix site that can be directly compared to the elemental analysis conducted by Viking, Pathfinder, MER, and MSL using variations of the X-ray fluorescence technique. Thus the instrument for use here is the duplicate of the most recent version of this instrument, the APXS being built for the MSL mission. We propose to include in the Icebreaker payload a duplicate of the MSL APXS. This APXS is an in-situ x-ray spectrometer using  $^{244}\text{Cm}$  sources for a combination of PIXE (Particle induced X-ray

emission) and XRF (X-ray Fluorescence). APXS measures elemental composition of samples provided by the sample handling system. APXS is TRL 9, from the MER mission and the MSL. Sensitivity and range requirements are identical to those for MSL. Only one soil sample needs to be measured to meet the mission requirement.

### **Surface Stereo Imager**

Icebreaker uses the Phoenix Surface Stereoscopic Imager (SSI) for monitoring drill and sample delivery operations, geologic mapping, multispectral analysis, and atmospheric observations. SSI is TRL 9 with heritage from Phoenix, Mars Polar Lander, and the Imager for Mars Pathfinder.

SSI consists of an articulated camera head with two eyes separated 20 cm. Each eye has a 12-position filter wheel in its optical path, a Cooke triplet focused to 2.3 m and a 1k x 1k CCD detector with heritage from MER PanCam and Phoenix. SSI stows to fit inside the backshell during cruise and is deployed upon release of an explosive bolt after landing. In its final position it is about 2 m above the surface. The camera has a clear view of the instruments and the terrain surrounding the lander. To allow the camera to view the drill site a notch is cut into the lander deck.

### **Planetary Protection Requirements**

Icebreaker Life must comply with the planetary protection requirements established by NASA policy NPD 8020.7E and detailed in NPR 8020.12B, “Planetary Protection Provisions for Robotic Extraterrestrial Missions”.

The relevant section of the COSPAR planetary protection policy relates to Category IV missions to Mars (COSPAR 2008): “Category IVa. Lander systems not carrying instruments for the investigations of extant martian life are restricted to a surface biological burden level of  $\leq 3 \times 10^5$  spores, and an average of  $\leq 300$  spores per square meter. Category IVb. For lander systems designed to investigate extant martian life, all of the requirements of Category IVa apply, along with the following requirement: The entire landed system is restricted to a surface biological burden level of  $\leq 30$  spores, or to levels of biological burden reduction driven by the nature and sensitivity of the particular life-detection experiments, whichever are more stringent OR the subsystems which are involved in the acquisition, delivery, and analysis of samples used for life detection must be sterilized to these levels, and a method of preventing recontamination of the sterilized subsystems and the contamination of the material to be analyzed is in place. Category IVc. For missions which investigate martian special regions (see definition below), even if they do not include life detection experiments, all of the requirements of Category IVa apply, along with the following requirement:

Case 1. If the landing site is within the special region, the entire landed system is restricted to a surface biological burden level of  $\leq 30$  spores.

Case 2. If the special region is accessed through horizontal or vertical mobility, either the entire landed system is restricted to a surface biological burden level of  $\leq 30$  spores, OR the subsystems which directly contact the special region shall be sterilized to these levels,

and a method of preventing their recontamination prior to accessing the special region shall be provided.”

Icebreaker will access the subsurface ice. If this ice is still considered a Special Region the planetary protection requirements for Icebreaker will be:

1. The main part of the spacecraft will need to satisfy Category IVa cleanliness
2. The drill and any portions of the spacecraft that could come in contact with the ice in the subsurface will need to satisfy Category IVc requirements which implies: sterilization by dry heat microbial reduction, biobarrier containment, and non-contact with unsterilized lander components during operations.

The Phoenix mission to Mars was considered a Category IVc mission because the arm on the lander accessed a special region – the subsurface ice – but the mission did not include life detection. As a result the arm was sterilized to the IVc case 2 requirements (Salinas et al. 2006, Bonitz et al. 2008) and the rest of the spacecraft was cleaned to IVa requirements. To ensure that the arm remained sterilized it was encased in a biobarrier cocoon (Salinas et al. 2006) during assembly and deployed from the cocoon on Mars. In addition, the mission was operated in a way that prevented the contact of the arm with non-sterilized components of the spacecraft. This final requirement meant that the robotic arm could not contact any of the instruments or the flight deck and therefore samples were dropped from some height above each instrument.

The concept of Special Regions on Mars was introduced (COSPAR, 2005; NASA, 2005) to refer to “. . . a region within which terrestrial organisms are likely to propagate, or a region which is interpreted to have a high potential for the existence of extant martian life forms. Given current understanding, this applies to regions where liquid water is present or may occur.” The definition of special regions on Mars continues to evolve (Beaty et al. 2006, Kminek et al. 2010). For example, in the Kminek et al. (2010) report on the COSPAR Mars Special Regions colloquium held in 2007 and it is unclear if they view the ice at the Phoenix landing site as a Special Region. For the purposes of our payload design we assume that the Icebreaker mission will also be a category IVc mission.

Sterilization for planetary protection purposes is based on dry heat microbial reduction (DHMR). This is a NASA certified process (Barengoltz 2004, NRC 2006) which involves temperatures in the range of 104 to 125°C with controlled absolute humidity for durations that depend on the temperature. Barengoltz (2004) points out that DHMR may be used without any assay and with the surface spore burden density specifications or with a prior assay to establish a lower pretreatment density.

Biobarrier containment was a significant challenge for the Phoenix arm (Salinas et al. 2006) and will be a challenge for the Icebreaker drill. Any sampling system that is in contact with drill will also have to be included within the biobarrier. On Mars, the drill assembly will have to come out of the biobarrier to commence operations. At the same

time, any part of the drill that penetrates subsurface (i.e. auger) must not come in contact with the sample transfer hardware that has not undergone DHMR.

The requirement that the drill does not contact parts of the spacecraft that have not undergone DHMR and biobarrier transport places important constraints on the design of the sample handling system. In particular there must be a way to break the chain of contact between the drill and the instruments on the lander deck. Thus the sample must be delivered across at least one “air gap”. On Phoenix this was accomplished by dropping the sample from the arm suspended over the instrument receiving the sample. On the IceBreaker drill this will also be accomplished using an “air-gap”. In particular, the cuttings conveyed up the auger will be brushed off and will gravity fall into a sample transfer hardware (e.g. a scoop).

Figure 8 is a diagram showing how the required biobarrier is implemented and how deployment on Mars brings the drill free of the biobarrier.

[Figure 8 here]

### **2018 Mission Profiles**

The Icebreaker Life mission has been designed based on the successful Phoenix mission in terms of mission platform and landing site. Phoenix landed at 68°N and a landed mass of 365 kg and a payload mass of 60 kg. Phoenix was a solar powered mission and operated from Ls 77 to 180. The Phoenix lander is able to accommodate the drill and the rest of the Icebreaker Life payload with only minor modifications.

We have developed a nominal mission scenario for Icebreaker for the 2018 opportunity. The nominal mission trajectory is a Type II with 9 months in cruise, launching December 2018. The Icebreaker spacecraft arrives over the northern plains of Mars in August 2019 (Ls=61) landing between 60°N and 70°N. Like Phoenix the Icebreaker lander is solar powered and operates only during the polar summer months. The power system is similar to that used on Phoenix based on two deployable solar arrays. This provides more than adequate power for the payload – the drill and the instruments. Icebreaker will complete 90% of its science objectives for full mission success by sol 40. The mission is planned to last for 90 sols, from Solar Longitude (Ls) 75-80 to Ls 170. Command, control, and data relay are all patterned after the Phoenix mission with relay to Mars orbiters and direct to Earth as a backup.

The Icebreaker Life payload has been designed around the Phoenix spacecraft and is targeted to a site near the Phoenix landing site. However the Icebreaker payload could be supported on other Mars landing systems. The SpaceX Dragon capsule has been developed primarily for crew and cargo delivery to the International Space Station. However it is also designed to land on Mars. Preliminary studies of the Dragon Mars lander (known as “Red Dragon”) show that it could support the Icebreaker payload for a landing either at the Phoenix site or at mid-latitudes. Presumably the Phoenix lander could also support a mid-latitude landing site.

The Icebreaker Life mission can be viewed as part of a new class of Astrobiology focused missions that are being proposed as followup missions to objects of interest in the search for evidence of life. Other missions include BOLD (Schulze-Makuch et al. 2012) and TWEEL (Levin et al. 2007) for Mars, and LIFE (Tsou et al. 2012) for Enceladus.

Using its robotic arm (Davé et al. 2012), the Icebreaker Life payload could easily pack duplicates of the samples in analyses into a sample return cache. This cache would then be a possible target for a future sample return mission. If organic biomarkers were known to be present in a sample cached on Mars this would be a strong motivation for returning that sample to Earth. Our return material is solid, rather refractory, organics and does not require special environmental control for Mars Sample Return. We are not studying or preserving ice so the return cache does not need to be pressure or temperature controlled. The cold ice-rich ground is a target because the ice may have been a past habitable environment and the ice protected and preserved organic remains.

In addition to ice-cemented ground, the Icebreaker payload would be well suited to searching for organic biomarkers in massive salt deposits if any were discovered on Mars. Salt is almost as good a preservative as ice. Reaching to 1 m depths would be desirable for better preservation.

#### **4. Conclusion**

The Phoenix mission results have shown that the ice-cemented ground in the northern plains of Mars are likely to be the most recently habitable location that is currently known on that planet. The near surface ice is a potential source of liquid water when Mars is at high obliquity. The low elevation allows for atmospheric pressure to be above the triple point of water, and the presence of perchlorate suggests a possible redox couple with ferrous iron that could support a chemotrophic metabolism. The discovery of perchlorate at 0.5% in the Martian soil has profound implications for possible life, the search for organics and life, and for human exploration.

The Phoenix mission confirmed the presence of ice-cemented ground but was not able to dig deeply into it. In addition, the organic analysis instrument on Phoenix (TEGA) was defeated by the presence of perchlorate in the soil. The next logical step in the exploration of this site is a mission that can sample deep into the ice-cemented ground and search directly for evidence of life. Studies in the polar regions of Earth have shown that ice is a good preservative for organics and for organic biomarkers of life.

Following this logic, we have developed the Icebreaker Life payload. The centerpiece of the Icebreaker payload is a drill capable of reaching to ~ 1m depth in ice-cemented ground. The cuttings from this drill are sampled and processed by the SOLID instrument that detects specific biomarkers which are organic molecules too complex to have been produced non-biologically. Thus a robust detection of such biomarkers would constitute persuasive evidence of life – sometime in the present or past on Mars. An example of such a biomarker is the enzymes associated with perchlorate consumption by

microorganisms. Persuasive evidence of life on Mars would have important scientific and societal implications. However, the lack of detection of biomarkers would also be important as this would signal a lack of Earth-like life, at least locally, although not necessarily a complete lack of life on Mars. Confirming a lack of life forms with similar biomarkers to Earth life would have implications for human exploration and contamination control on returned samples.

Drilling to one meter on Mars is a challenge but we have designed and demonstrated a drill that can accomplish this task. Testing in simulated Mars conditions, and in the Antarctic and Arctic, have brought this drill to high technology readiness level (Paulsen et al. 2011).

In addition to biomarker detection the Icebreaker Life payload includes a version of the Phoenix Wet Chemistry Laboratory (WCL) for analysis of the dissolved salts, including nitrate and perchlorate. An alpha proton X-ray fluorescence unit is also included to allow for a direct comparison between the soils in the northern plains and the soils from lower latitudes investigated on previous missions.

Organic analysis remains a challenge due to high perchlorate, and the nominal mission relies on the SOLID instrument for organic detection which is capable of detecting organics in the presence of perchlorates. Work is also underway to develop and test laser desorption mass spectroscopy as a method to detect organics in perchlorate rich soils. Such an instrument may have applicability to Discovery class missions.

Our mission design is based on the highly capable and successful Phoenix spacecraft system. Our mission would land near the Phoenix site in 2018 and operate over a Martian summer. While the Phoenix system is ideal for the Icebreaker Life payload other landing systems could be used. Icebreaker life can readily be adapted to cache samples in advance of a Mars Sample Return.

### **Acknowledgements**

This work was supported by the NASA ASTEP and ASTID programs.

### **References**

- Aubrey, A., et al. (2006) Sulfate minerals and organic compounds on Mars. *Geology* 34, 357–360.
- Bada, J.L. (2004) How life began on Earth: a status report. *Earth and Planetary Science Letters* 226 (2004) 1–15
- Bada J.L., et al., (2008) Urey: Mars Organic and Oxidant Detector. *Space Sci Rev.* 135, 269–279
- Bakermans, C., Tsapin, A.I., Souza-Egipsy, V., Gilichinsky, D.A., and Nealson, K.H. (2003) Reproduction and metabolism at 10°C of bacteria isolated from Siberian permafrost. *Environ. Microbiol.* 5, 321–326.
- Bandfield, J.L., Glotch, T.D., and Christensen, P.R. (2003). Spectroscopic identification of carbonates in the Martian dust. *Science* 301(1084), 1084-1087.



- Barengoltz, J. (2004) A review of the approach of NASA projects to planetary protection compliance. IEEEAC psprt #1485.
- Beatty, D.K., Buxbaum, M., Meyer, N., Barlow, W., Boynton, B., Clark, J., Deming, P.T., Doran, K., Edgett, S., Hancock, J., Head, M., Hipkin, V., Kieft, T., Mancinelli, R., McDonald, E., McKay, C., Mellon, M., Newsom, H., Ori, G., Paige, D., Schuerger, A.C., Sogin, M., Spry, J.A., Steele, A., Tanaka, K., and Voytek, M. 2006. Findings of the Mars Special Regions Science Analysis Group. *Astrobiology* 6, 667–732.
- Bibring, J.P., Langevin, Y., Mustard, J.F., Poulet, F., Arvidson, R., Gendrin, A., Gondet, B., Mangold, N., Pinet, P., and Forget, F. (2006) Global mineralogical and aqueous Mars history derived from OMEGA/Mars express data. *Science* 312, 400–404.
- Bibring, J. P., et al. (2007) Coupled ferric oxides and sulfates on the Martian surface, *Science*, 317, 1206–1210.
- Biemann, K., et al. (1977) The search for organic substances and inorganic volatile compounds in the surface of Mars. *J. Geophys. Res.* 82(28), 4641-4658.
- Bonitz, R. G., et al. (2008) NASA Mars 2007 Phoenix lander robotic arm and icy soil acquisition device. *J. Geophys. Res.* 113, E00A01, doi:10.1029/2007JE003030.
- Boynton, W.V., et al. (2002) Distribution of hydrogen in the near surface of Mars: evidence for subsurface ice deposits. *Science* 297(5578), 81-85.
- Botta, O., and Bada, J.L. (2002) Extraterrestrial organic compounds in meteorites. *Surv. Geophys.* 23, 411–467.
- Boynton, W. V., et al. (2009), Evidence for calcium carbonate at the Mars Phoenix landing site, *Science*, 325, 61 – 64.
- Capone, D. G., Popa, R., Flood, B., and Nealson, K. H. (2006) Follow the nitrogen. *Science* 312, 708–709.
- Carr, M.H., (1981) *The Surface of Mars* Yale University Press New Haven, Conn.
- Catling, D. C., et al. (2010) Atmospheric origins of perchlorate on Mars and in the Atacama, *J. Geophys. Res.*, 115, E00E11, doi:10.1029/2009JE003425.
- Chevrier, V.F., et al. (2009) Stability of perchlorate hydrates and their liquid solutions at the Phoenix landing site, Mars. *Geophys. Res. Ltrts* 36, doi:10.1029/2009GL037497.
- Christensen, P.R. et al. Mars Global Surveyor Thermal Emission Spectrometer experiment: Investigation description and surface science results. *J. Geophys. Res.* 106 (2001) 23,823–23,871.
- Christensen, P.R., et al. (2004) Mineralogy at Meridiani Planum from the mini-TES experiment on the Opportunity Rover. *Science* 306, 1733-1739.
- Clark, B. C., et al. (1976) Inorganic Analyses of Martian surface samples at the Viking landing sites. *Science* 194, 1283–1288.
- Clark, B. C., et al. (2005) Chemistry and mineralogy of outcrops at Meridiani Planum, *Earth Planet. Sci. Lett.*, 240, 73–94.
- Clark, B. C. (1993) Geochemical components in Martian soil. *Geochim. Cosmochim. Acta*, 57, 4575–4581.
- Clark, B.C., and van Hart, D.C. (1981) The salts of Mars. *Icarus* 45, 370–378.
- Coates, J.D., and Achenbach, L.A. (2004) Microbial perchlorate reduction: rocket-fueled metabolism. *Nat. Rev. Microbiol.* 27, 569–580.
- Coates, J.D., Michaelidou, U., O'Connor, S.M., Bruce, R.A., Achenbach, L.A. (2000) The diverse microbiology of (per)chlorate reduction, p. 257-270. In E.D. Urbansky (ed.), *Perchlorate in the environment*. Kluwer Academic/Plenum, New York, NY.

- Cockell, C.S., Lee, P., Osinski, G., Horneck, G., and Broady, P. (2002) Impact-induced microbial endolithic habitats. *Meteoritics and Planetary Science*, 37, 1287–1298.
- COSPAR (2005) COSPAR Planetary Protection Policy (20 October 2002; amended 24 March 2005). Available at: <http://www.cosparhq.org/scistr/PPPolicy.htm>.
- Costard, F., Forget, F., Mangold, N., Peulvast, J.P. (2002) Formation of Recent Martian Debris Flows by Melting of Near-Surface Ground Ice at High Obliquity. *Science*, 295: 110-113.
- Cull, S.C., Arvidson, R.E., Catalano, J.G., Ming, D.W., Morris, R.V., Mellon, M.T., and Lemmon, M. (2010) Concentrated perchlorate at the Mars Phoenix landing site: Evidence for thin film liquid water on Mars, *Geophys. Res. Lett.*, 37, L22203, doi:10.1029/2010GL045269.
- Davé, A.I., et al. (2012) The Sample Handling System for the Mars Icebreaker Life Mission: From dirt to data. In preparation.
- de Diego-Castilla, G., Cruz-Gil, P., Mateo-Martí, E., Fernández-Calvo, P., Rivas, L.A., Parro, V. (2011) Assessing antibody microarrays for space missions: effect of long term storage, gamma radiation, and temperature shifts on printed and fluorescently labeled antibodies. *Astrobiology* 11, 759-773.
- Doran, P.T., McKay, C.P., Clow, G.D., Dana, G.L., Fountain, A.G., Nysten, T. & Lyons, W.B. (2002) Valley floor climate observations from the McMurdo Dry Valleys, Antarctica, 1986 – 2000. *J. Geophys. Res.*, 107(D24), 4772, doi:10.1029/2001JD002045.
- Ehlmann, B.L. et al. (2008) Orbital identification of carbonate-bearing rocks on Mars. *Science* 322, 1828-1832.
- Fanale, F.P., Salvail, J.R., Zent, A.P., and Postawko, S.E. (1986), Global distribution and migration of subsurface ice on Mars. *Icarus*, 67, 1 – 18.
- Farmer, C. B., and Doms, P.E. (1979) Global seasonal variation of water vapor on Mars and the implications of permafrost, *J. Geophys. Res.*, 84, 2881 – 2888.
- Feldman, W.C., et al. (2004) Global distribution of near-surface hydrogen on Mars, *J. Geophys. Res.*, 109, E09006, doi:10.1029/2003JE002160.
- Feldman, W.C., Bandfield, J.L., Diez, B., Elphic, R.C., Maurice, S., and Nelli, S.M. (2008) North to south asymmetries in the water-equivalent hydrogen distribution at high latitudes on Mars, *J. Geophys. Res.*, 113, E08006, doi:10.1029/2007JE003020.
- Feldman, W. C., Mellon, M.T., Gasnault, O., Maurice, S., and Prettyman, T.H. (2008) Volatiles on Mars: Scientific results from the Mars Odyssey Neutron Spectrometer, in *The Martian Surface: Composition, Mineralogy, and Physical Properties*, edited by J. F. Bell, pp. 125 – 148, Cambridge Univ. Press, London.
- Fernández-Calvo, P., et al. (2006) A multi-array competitive immunoassay for the detection of broad range molecular size organic compounds relevant for astrobiology. *Planet Space Sci* 54, 1612–1621.
- Flynn, G.J., and McKay, D.S. (1990) An assessment of the meteoritic contribution to the martian soil. *Journal of Geophysical Research*. 95(B9):14497-14509.
- Flynn, G.J. (1996) The delivery of organic matter from asteroids and comets to the early surface of Mars. *Earth, Moon, and Planets*. 72:469-474.
- Gilichinsky D, Vorobyova EA, Erokhina LG, Fedorov-Davydov DG, Chaikovskaya NR (1992) Long-term preservation of microbial ecosystems in permafrost. *Adv Space Res* 12:255–263

- Glass, B., H. Cannon, M. Branson, S. Hanagud, and G. Paulsen. (2008) DAME: Planetary-prototype drilling automation. *Astrobiology* 8, 653-664.
- Golombek, M.P. (1999) Martian climate: A message from warmer times. *Science* 283, 1470-1471
- Hecht, M.H., Kounaves, S.P., Quinn, R.C., West, S.J., Young, S.M., Ming, D.W., Catling, D.C., Clark, B.C., Boynton, W.V., Hoffman, J., Deflores, L.P., Gospodinova, K., Kapit, J., and Smith, P.H. (2009) Detection of perchlorate and the soluble chemistry of martian soil at the Phoenix lander site. *Science* 325:64–67.
- Jakosky, B.M., Nealon, K.H., Bakermans, C., Ley, R.E., Mellon, M.T. (2003) Subfreezing activity of microorganisms and the potential habitability of Mars' polar regions. *Astrobiology*, 3, 343-350.
- Johnson, S.S., et al. (2007) Ancient bacteria show evidence of DNA repair. *Proceedings National Academy of Sciences of the USA* 104, 14401–14405.
- Kanavarioti, A., and Mancinelli, R.L. (1990) Could organic matter have been preserved on Mars for 3.5 billion years? *Icarus* 84, 196–202.
- Keller, J. M., et al. (2006), Equatorial and midlatitude distribution of chlorine measured by Mars Odyssey GRS, *J. Geophys. Res.*, 111, E03S08, doi:10.1029/2006JE002679
- Klein, H.P. (1978) The Viking biological experiments on Mars. *Icarus* 34, 666-674
- Klein, H.P. (1999) Did Viking Discover Life on Mars? *Orig. Life and Evol. Biosphere*. 29, 625-631.
- Klingler, J.M., Mancinelli, R.L., and White, M.R. (1989) Biological nitrogen fixation under primordial martian partial pressures of dinitrogen. *Adv. Space Res.* 9, 173 - 176.
- Kminek, G., et al. (2010) Report of the COSPAR mars special regions colloquium, *Advances in Space Research*, 46, 811-829.
- Kounaves, S. P., et al. (2010), Soluble sulfate in the martian soil at the Phoenix landing site, *Geophys. Res. Lett.*, 37, L09201, doi:10.1029/ 2010GL042613.
- Levin, G.V., Miller, J.D., Straat, P.A., Lodder, R.A., Hoover, R.B. (2007). Detecting Life and Biology-Related Parameters on Mars, *IEEE Aerospace Conf.*, 1, 1-15.
- Laskar, J., Levrard, B., and Mustard, J. F. (2002) Orbital forcing of the martian polar layered deposits. *Nature*, 419, 375–377.
- Logan, B. (1998) A review of chlorate- and perchlorate-respiring microorganisms. *Bioremediation Journal*. 2: 69-79.
- Mahaffy, P. et al. (2012) The Sample Analysis at Mars Investigation and Instrument Suite. *Space Science Reviews*, in press.
- Malin M.C. and Carr M.H. (1999) Groundwater formation on Martian valleys. *Nature* 397, 589–591.
- Malin, M.C. and Edgett, K.S. (2000) Evidence for recent groundwater seepage and surface runoff on Mars. *Science* 288, 2330 – 2335.
- Manning, C.V., Zahnle, K.F., and McKay, C.P. (2009). Impact processing of nitrogen on early Mars. *Icarus*, 199, 273-285.
- McEwen, A.S., et al. (2007) A closer look at water-related geologic activity on Mars. *Science* 317, 1706-1709.
- McEwen, A.S., et al. (2011). Seasonal flows on warm Martian slopes, *Science* 333, 740-743, 2011

- McKay, C.P. (2012) Full solar spectrum measurements of absorption of light in a sample of the Beacon Sandstone containing the Antarctic cryptoendolithic microbial community. *Antarctic Science*, 24, 243-248.
- McSween HY Jr. (1984) SNC Meteorites; are they Martian rocks? *Geology* 12, 3–6.
- Mellon, M.T., and Jakosky, B.M. (1993) Geographic variations in the thermal and diffusive stability of ground ice on Mars, *J. Geophys. Res.*, 98, 3345 – 3364.
- Mellon, M.T. and Jakosky, B.M. (1999) The distribution and behavior of Martian ground ice during past and present epochs. *J. Geophys. Res.* 100(E6), 11,781-11,799.
- Mellon, M.T., Feldman, W.C., and Prettyman, T.H. (2004), The presence and stability of ground ice in the southern hemisphere of Mars. *Icarus*, 169, 324 – 340.
- Mellon, M.T., et al. (2009) Ground ice at the Phoenix landing site: Stability state and origin. *J. Geophys. Res.*, 114, doi:10.1029/2009JE003417.
- Mellon, M.T., et al. (2009), The periglacial landscape at the Phoenix landing site, *J. Geophys. Res.*, 114, E00E06, doi:10.1029/2009JE003418.
- MEPAG. (2010) Mars science goals, objectives, investigations, and priorities, white paper posted September 2010 by the Mars Exploration Program Analysis Group (MEPAG). Available online at <http://mepag.jpl.nasa.gov/reports/index.html>.
- Miller, S.L. (1953) A production of amino acids under possible primitive Earth conditions. *Science* 117, 528–529.
- Ming, D. W., et al. (2009) Combustion of organic molecules by the thermal decomposition of perchlorate salts: Implications for organics at the Mars Phoenix Scout Landing Site, Paper presented at the 40th Lunar and Planetary Science Conference, Woodlands, Tex.
- Möhlmann, D. (2010) The three types of liquid water in the surface of present Mars. *International Journal of Astrobiology* 9, 45–49.
- Moores, J. E., and Schuerger, A.C. (2012), UV degradation of accreted organics on Mars: IDP longevity, surface reservoir of organics, and relevance to the detection of methane in the atmosphere, *J. Geophys. Res.*, 117, E08008, doi:10.1029/2012JE004060.
- Morris, R.V., et al. (2010). Identification of carbonate-rich outcrops on Mars by the Spirit rover *Science* 329, 421–424,
- National Aeronautics and Space Administration (2005) Planetary Protection Provisions for Robotic Extraterrestrial Missions, NPR 8020.12C, National Aeronautics and Space Administration, Washington, DC, 2005.
- National Research Council (2006) “Preventing the Forward Contamination of Mars”, National Academy Press, Washington, DC.
- Navarro-Gonzalez, R., et al. (2006) The limitations on organic detection in Mars-like soils by thermal volatilization–gas chromatography–MS and their implications for the Viking results. *Proc. Nat. Acad. Sci.* 103, 16089 –16094.
- Navarro-Gonzalez, R., et al. (2010a) Pyrolysis of Atacama soils with added perchlorates: implications for the Viking results. *Astrobiology Science Conference*, abstract #5072.
- Navarro-Gonzalez, R., et al. (2010b) Reanalysis of the Viking results suggests perchlorate and organics at mid-latitudes on Mars, *J. Geophys. Res.*, submitted.
- Nixon, S.L., Cockell, C.S., Tranter, M. (2012) Limitations to a microbial iron cycle on Mars. *Planetary Space Science*. In press.
- Ostroumov, V. E., and Siegert, C. (1996) Exobiological aspects of mass transfer in microzones of permafrost deposits. *Adv. Space Res.* 18(12):79–86.

- Pace, N. (2001) The universal nature of biochemistry. *Proc. Natl Acad. Sci. USA* 98, 805–808.
- Parnell, J., et al. (2007) Searching for life on Mars: selection of molecular targets for ESA's Aurora ExoMars mission. *Astrobiology* 7, 578–604.
- Parro, V., et al. (2005) Instrument development to search for biomarkers on mars: terrestrial acidophile, iron-powered chemolithoautotrophic communities as model systems. *Planet. Space Sci.* 53, 729-737.
- Parro, V., Rivas, L.A. and Gómez-Elvira, J. (2007) Protein microarray-based strategies for life detection in astrobiology. *Space Sci. Reviews* 135(1-4), 293-311.
- Parro, V., et al. (2011) SOLID3 a multiplex antibody microarray-based optical sensor instrument for in situ life detection in planetary exploration. *Astrobiology* 11: 15-28
- Paulsen, G., et al. (2006) Robotic drill systems for planetary exploration. Proceedings of AIAA Space, San Jose, CA.
- Paulsen, G., et al. (2011) Testing of a 1 meter Mars IceBreaker Drill in a 3.5 meter Vacuum Chamber and in an Antarctic Mars Analog Site, AIAA SPACE 2011 Conference & Exposition, Long Beach, September 26-29, 2011
- Quinn, R.C., and Zent, A.P. (1999) Peroxide-modified titanium dioxide: a chemical analog to putative martian soil oxidants. *Origins Life Evol. Biosph.* 29, 59–72.
- Quinn, R.C., Zent, A.P., Grunthner, F.J., Ehrenfreund, P., Taylor, C.L., Garry, J.R.C. (2005) Detection and characterization of oxidizing acids in the Atacama Desert using the Mars Oxidation Instrument. *Planetary Space Science* 53, 1376–1388.
- Quinn, R.C., Ehrenfreund, P., Grunthner, F.J., Taylor, C.L., and Zent, A.P. (2007) Decomposition of aqueous organic compounds in the Atacama Desert and in martian soils. *J. Geophys. Res.* 112, doi: 10.1029=2006JG000312.
- Quinn, R.C., Grunthner, P.J., Taylor, C.L., Bryson, C.E., Grunthner, F.J. (2011) The radiolytic decomposition of soil perchlorates on Mars. *LPSC Abstract*
- Reider, R., et al. (2004) Chemistry of rocks and soils at Meridiani Planum from the Alpha Particle X-ray Spectrometer. *Science* 306, 1746–1749.
- Rennó, N.O. et al. (2009) Possible physical and thermodynamical evidence for liquid water at the Phoenix landing site. *Journal of Geophysical Research*, 114, doi:10.1029/2009JE003362.
- Richardson, M. I., and Mischna, M.A. (2005) Long-term evolution of transient liquid water on Mars. *J. Geophys. Res.* 110:E03003.
- Rivkina, E.M., Friedmann, E.I., McKay, C.P., and Gilichinsky, D.A. (2000) Metabolic activity of permafrost bacteria below the freezing point, *Appl. Environ. Microbio.*, 66, 3230-3233.
- Sagan, C., and Pollack, J. (1974) Differential transmission of sunlight on Mars: biological implications. *Icarus*, 21, 490–495.
- Salinas, Y. et al. (2006) Bio-barriers: Preventing forward contamination and protection planetary astrobiology instruments. *IEEEAC paper #1216*.
- Schulze-Makuch, D., et al. (2012) The Biological Oxidant and Life Detection (BOLD) mission: A proposal for a mission to Mars. *Planetary and Space Science* 67, 57–69.
- Sephton, M.A., and Botta, O. (2005) Recognizing life in the Solar System: guidance from meteoritic organic matter. *International Journal Astrobiology* 4, 269-276.
- Smith, H.D. and C.P. McKay (2005) Drilling in ancient permafrost on Mars for evidence of a second genesis of life, *Planet. Space Sci.*, 53, 1302-1308.

- Smith, P.H. et al. (2009) H<sub>2</sub>O at the Phoenix Landing Site. *Science*, 325, 58-61.
- Schuerger, A.C., Moores, J.E., Clausen, A.C., Barlow, N.G., and Britt, D.T. (2012), Methane from UV-irradiated carbonaceous chondrites under simulated Martian conditions., *J. Geophys. Res.*, 117, E08007, doi:10.1029/2011JE004023.
- Squyres, S.W., Grotzinger, J.P., Arvidson, R.E., Bell, J.F., Calvin, III, W., Christensen, P.R., Clark, B.C., Crisp, J.A., Farrand, W.H., Herkenhoff, K.E., Johnson, J.R., Klingelhöfer, G., Knoll, A.H., McLennan, S.M., McSween, H.Y., Morris, Jr., R.V., Rice, J.W., Rieder, Jr., R. and Soderblom, L.A. (2004) In Situ Evidence for an Ancient Aqueous Environment at Meridiani Planum, Mars. *Science* 306, 1709-1714.
- Squyres SW, Arvidson RE, Bell JF, Calef F, Clark BC, Cohen BA, Crumpler LA, De Souza PA, Farrand WH, Gellert R, Grant J, Herkenhoff KE, Hurowitz JA, Johnson JR, Jolliff BL, Knoll AH, Li R, McLennan SM, Ming DW, Mittlefehldt DW, Parker TJ, Paulsen G, Rice MS, Ruff SW, Schröder C, Yen AS, Zacny K. (2012) Ancient impact and aqueous processes at Endeavour Crater, Mars. *Science*, 336, 570-576.
- Stoker, C.R., and Bullock, M.A. (1997) Organic degradation under simulated Martian conditions. *Journal of Geophysical Research* 102, 10,881-810,888.
- Stoker, C. R., et al. (2010), Habitability of the Phoenix landing site, *J. Geophys. Res.*, 115, E00E20, doi:10.1029/2009JE003421.
- Straub, K. L., Benz, M., Schink, B. and Widdel, F. (1996). Anaerobic, nitrate-dependent microbial oxidation of ferrous iron. *Appl Environ Microbiol* 62, 1458–1460.
- Tsou, P. et al. (2012) LIFE: Life investigation for Enceladus a sample return mission concept in search for evidence of life. *Astrobiology* 12, 730–742.
- Valdivia-Silva, J.E., Navarro-González, R., Ortega-Gutierrez, F., Fletcher, L.E., Perez-Montaña, S., Condori-Apaza, R., McKay, C.P. (2011) Multidisciplinary approach of the hyperarid desert of Pampas de La Joya in southern Peru as a new Mars-like soil analogue, *Geochimica et Cosmochimica Acta*. 75, 1975–1991.
- Vishnivetskaya T, Kathariou S, McGrath J, Gilichinsky DA and Tiedje JM (2000) Low-temperature recovery strategies for the isolation of bacteria from ancient permafrost sediments. *Extremophiles* 4, 165–173.
- Vishnivetskaya TA, Petrova MA, Urbance J, Ponder M, Moyer CL, Gilichinsky DA & Tiedje JM (2006) Bacterial community in ancient Siberian permafrost as characterized by culture and culture-independent methods. *Astrobiology* 6, 400–414.
- Vorobyova, E. et al. (1997) The deep cold biosphere: facts and hypotheses. *FEMS Microbiology Reviews* 20, 277-290.
- Wänke, H., et al. (2001) Chemical composition of rocks and soils at the Pathfinder site. *Space Science Reviews* 96: 317-330, 2001.
- Weber KA, Urrutia MM, Churchill PF, et al. (2006) Anaerobic redox cycling of iron by freshwater sediment microorganisms. *Environ Microbiol* 8, 100–13.
- Zacny, K., et al. (2008) Drilling Systems for Extraterrestrial Subsurface Exploration, *Astrobiology Journal*, Volume 8, Number 3, 2008, DOI: 10.1089/ast.2007.0179
- Zacny K., and Cooper, G. (2006) Considerations, Constraints and Strategies for Drilling on Mars. *Planetary and Space Science* 54, 345-356.
- Zacny, K., G. Paulsen, M. Szczesiak, J. Craft, P. Chu, C. McKay, B. Glass, A. Davila, M. Marinova, W. Pollard, A. Jackson, (2012a), LunarVader: Development and Testing of a Lunar Drill in a Vacuum Chamber and in the Lunar Analog Site of the Antarctica. In review. *J. Aerospace Engineering*.

- Zacny K. Paulsen G. Mellerowicz B. Craft J. McKay C. Glass B. Davila A. Marinova M. Dave A. Thompson S., (2012b), The Icebreaker: Mars Drill and Sample Delivery System, Abstract 1153, LPSC, 19-23 March, 2012
- Zacny, K., Paulsen, G., McKay, C., Glass, B., Davila, A., Marinova, M. (2012c), IceBreaker Mars Drill and Sample Delivery System. In prep. *Acta Geotechnica*
- Zent, A. (2008) A historical search for habitable ice at the Phoenix landing site. *Icarus* 196, 385–408.
- Zent, A.P., and McKay, C.P. (1994) The chemical reactivity of the martian soil and implications for future missions. *Icarus*, 108, 146-157.

Table 1. Polar Conditions

Conditions at the North Polar regions favorable to habitability
1. Pressure above triple point (610 Pa)
2. Ice near the surface
3. High insolation during summer

Table 2. Expected Range of Organics on Mars

Accumulation Rate	Organic content *	Note on accumulation rate
$10^{-9}$ m/yr	0.1%	Global average redeposition rate (Golombek 1999)
$1.7 \times 10^{-6}$ m/yr	0.3 ppm	Accumulation rate to give 1 m depth in 6 Myr
$5 \times 10^{-4}$ m/yr	0.001 ppm	Accumulation rate at north polar layered deposits (Laskar et al. 2002)

\*assumes a total organic infall rate on Mars of  $10^{-10}$  g C/yr.

Table 3. Examples of targeted biomolecules and organics

Complex Biomolecules (Persuasive Evidence of Life)	Example Targets
Environmental biomolecules	Biomolecules from terrestrial environmental samples (e.g., Antarctic ground ice) or microbial communities (e.g., perchlorate reducers).
Universal proteins, polysaccharides, nucleic acids, and some of their derivatives	Molecules present in a broad group of organisms (e.g., CspA required for cold adaptation, perchlorate reductase, metal oxidation/reduction)
Universal metabolic molecules	ATP for cellular energy conversion, NAD <sup>+</sup> involved in redox reactions, cAMP for intracellular signal transactions
Intermediate Complex Molecules (Signs of Life)	Example Targets
Nano- and Oligopeptides	Chains of Asp, Glu, Trp, Tyr, Phe, etc.
Polymeric compounds	Humic acids, polyglutamic acid
Simple Organics	Example Targets
PAHs (Polycyclic Aromatic Hydrocarbons)	Naphthalene, diphenylphenol
Carboxylic acids	Mellitic acid, benzoic acid



Table 4. A summary of payload characteristics and specifications

<b>IceBreaker</b> Goals & Objectives	Measurement		WCL	SOLID	APXS	Drill			SSI	Drill bit	
Life	biomarkers	Search for signs of life (biomarkers) associated with the ice at the Phoenix landing site dry surface and ice-cemented subsurface		X				X		X	X
	Organics	Measure organics concentration versus depth in presence of perchlorates in the dry surface and ice-cemented subsurface					X		X		
	Habitability	Liquid Water: Measure the distribution of perchlorate & other salts versus depth in the dry surface & in ice-cemented ground	X		X		X				
		Energy: Measure concentration of potential redox couples of biological use	X		X		X		X		
		Nutrients: Measure the concentration of biogenic elements			X		X				
Climate history & Crust Evolution	Water	Measure the distribution of perchlorate and other salts versus depth in the dry surface and in the ice-cemented ground	X	X			X				
		Detect presence of dust-free layers in the subsurface.					X		X	X	
		Image landscape to characterize patterned ground & rock sizes.							X		
Human Exploration	Ice	Obtain readings of soil mechanical properties: resistance variation with depth and temperature. Demonstrate technology for drilling on Mars.				X	X	X	X	X	X

## List of Figures

Figure 1. Light-toned ice at the Phoenix landing site. The change, due presumably to evaporation over the four sol period, indicates that the light-toned material is indeed ice and not salt or carbonate.

Figure 2. Figure 2. Orbital variations and north polar insolation over the past 20 Myr (reprinted with permission from Laskar et al. 2002).

Figure 3. Icebreaker's configuration with drill, sample transfer system, and science instruments.

Figure 4. Engineering detail of the Icebreaker Drill.

Figure 5. Engineering details of the sample handling system, showing the brush, air gap, and positive displacement system which can inject sticky samples. Also shown is the mechanism for injecting the organic blank sample (From Davé et al. 2021, in preparation).

Figure 6. Functional schematic of SOLID.

Figure 7. Functional schematic and image of the Phoenix WCL.

Figure 8. Diagram showing the drill within the biobarrier and how it is arranged on the Phoenix lander. The Figure also shows how the drill is deployed and the biobarrier ejected.

Figure 1. Light-toned ice at the Phoenix landing site. The change, due presumably to evaporation over the four sol period, indicates that the light-toned material is indeed ice and not salt or carbonate.

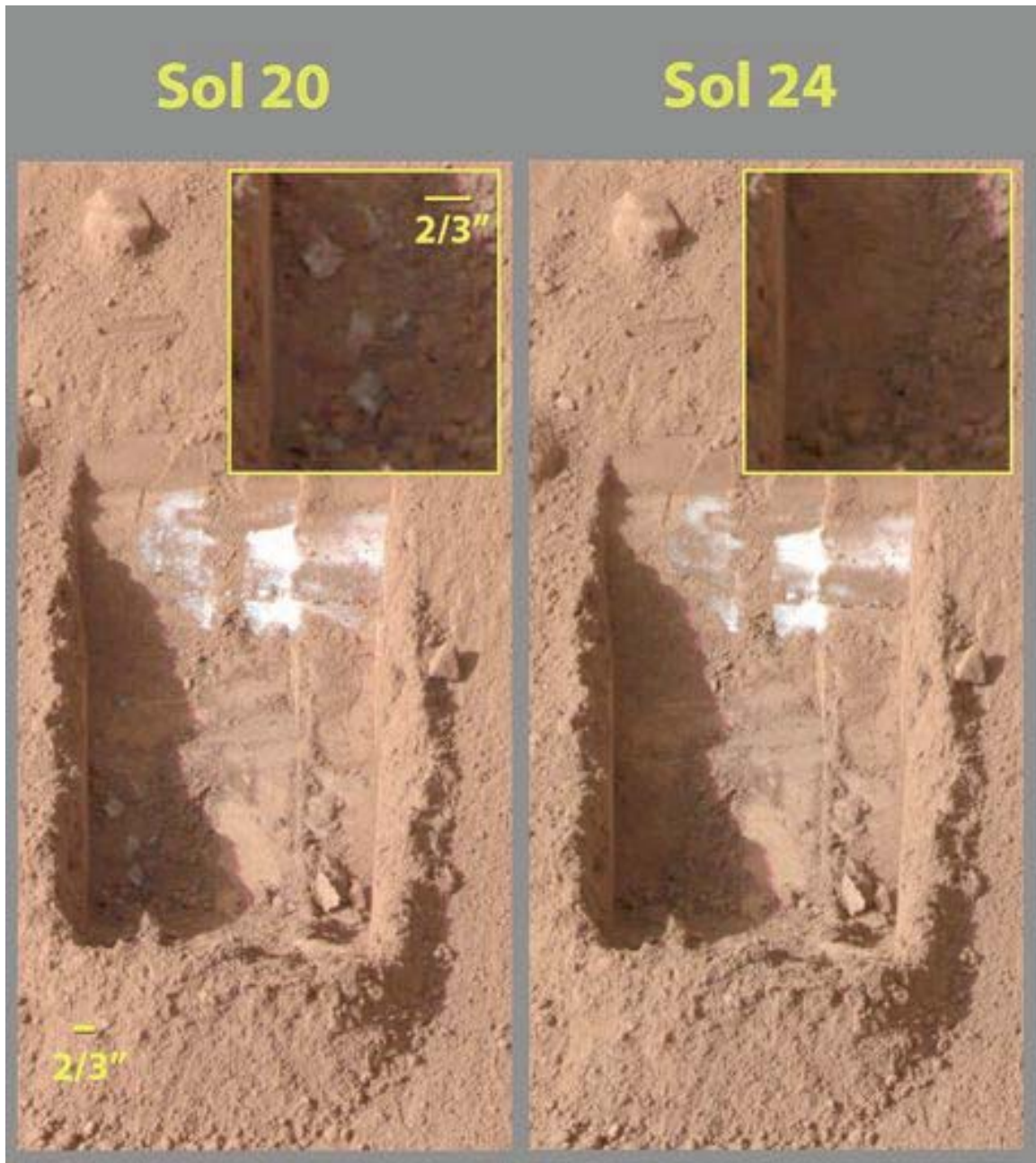

Figure 2. Figure 2. Orbital variations and north polar insolation over the past 20 Myr (reprinted with permission from Laskar et al. 2002).

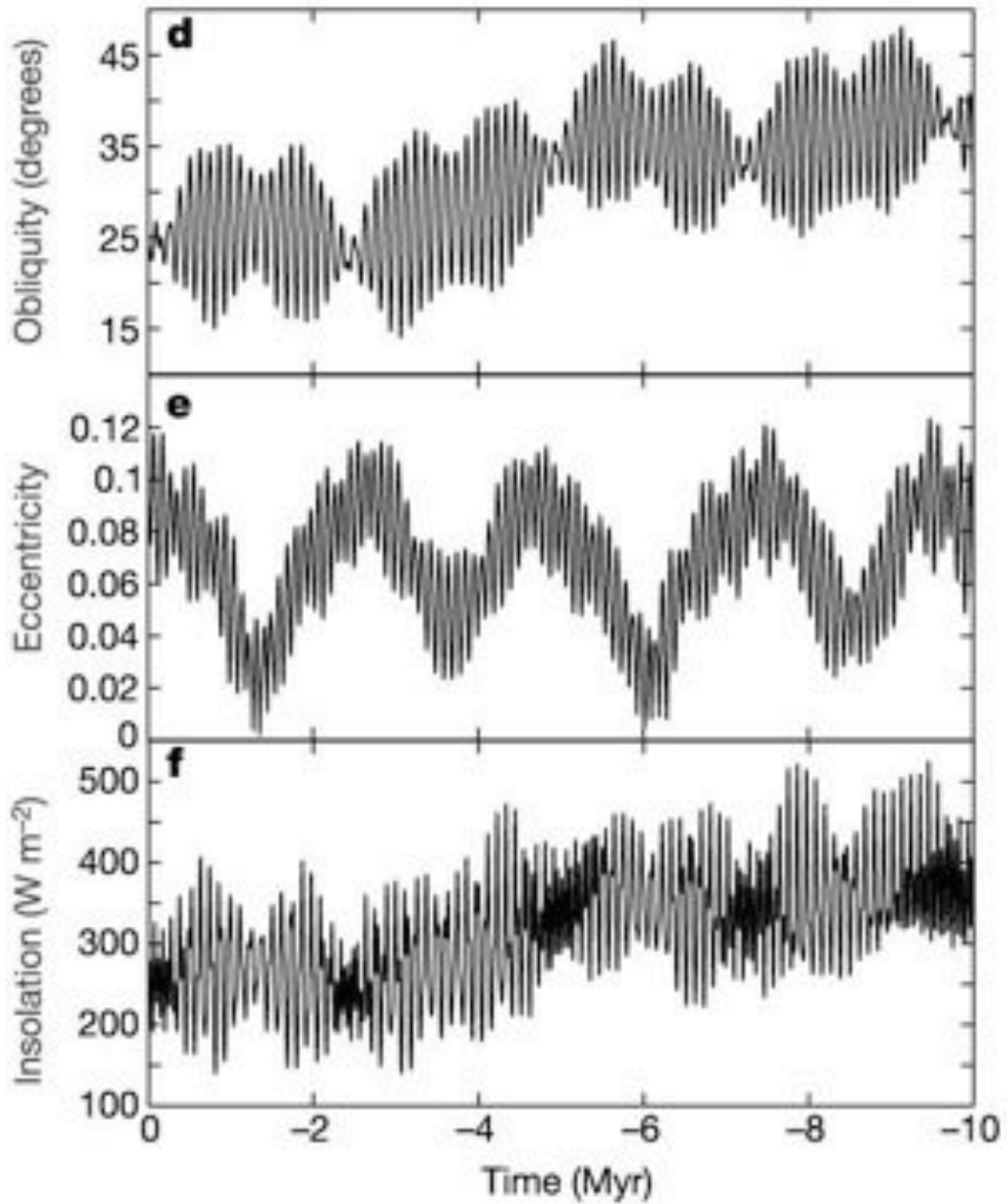

Figure 3. Icebreaker's configuration with drill, sample transfer system, and science instruments.

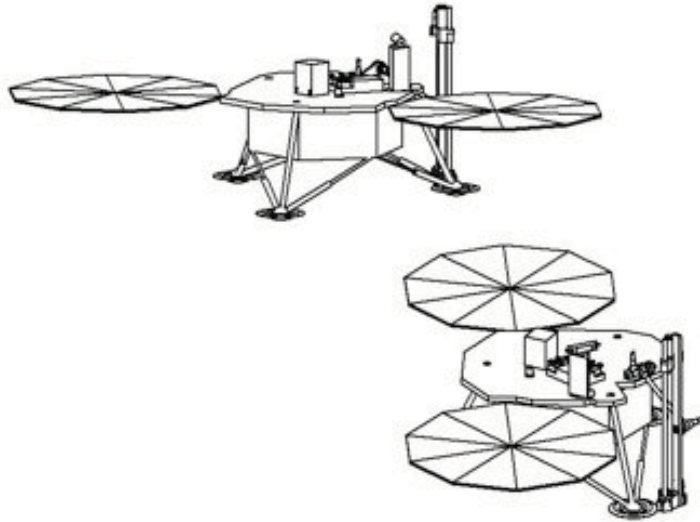

Figure 4. Engineering detail of the Icebreaker Drill and photo of the unit.

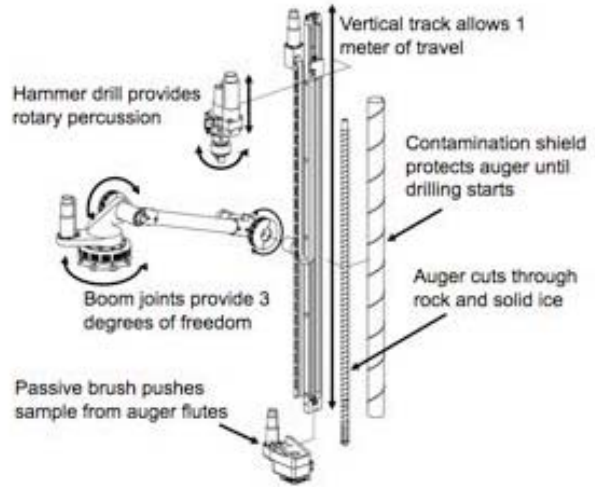
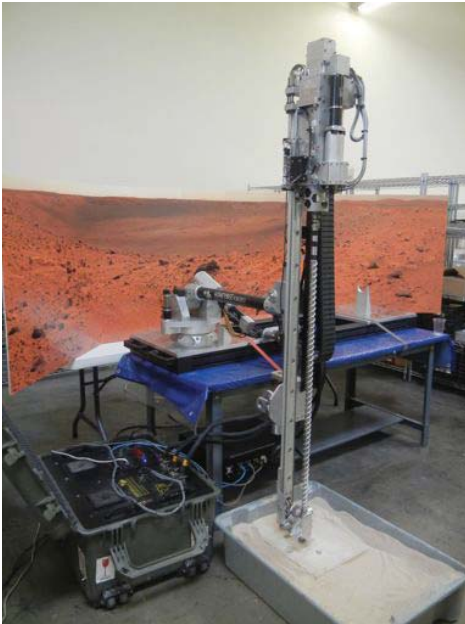

Figure 5. Engineering details of the sample handling system, showing the brush, air gap, and positive displacement system which can inject sticky samples. Also shown is the mechanism for injecting the organic blank sample (From Davé et al. in preparation).

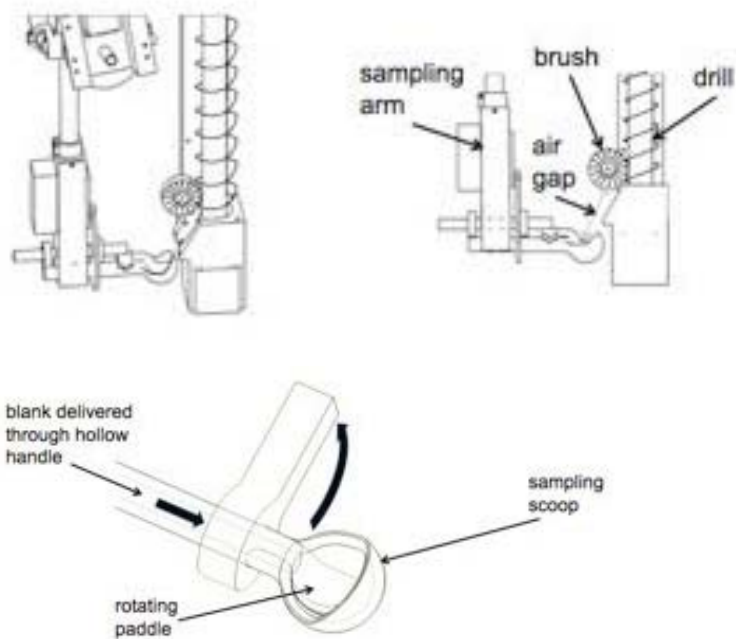

Figure 6. Functional schematic of SOLID.

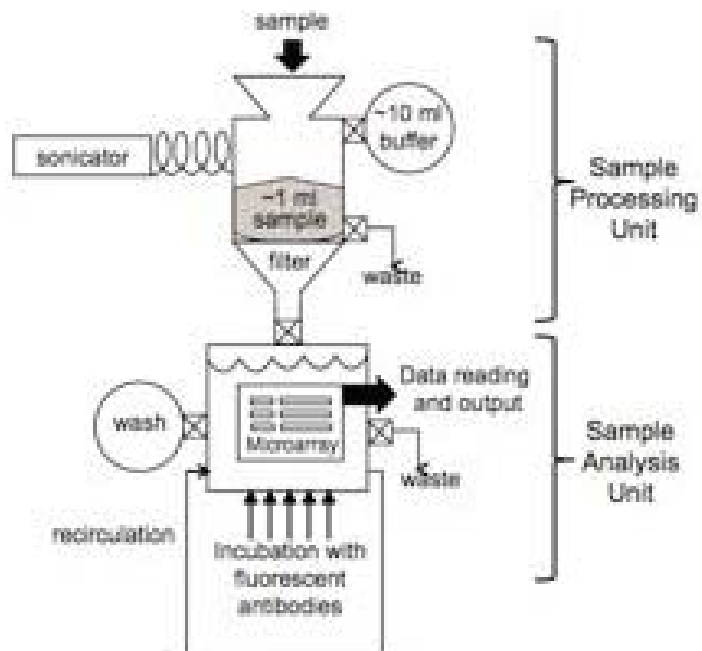



Figure 7. Functional schematic and image of the Phoenix WCL.

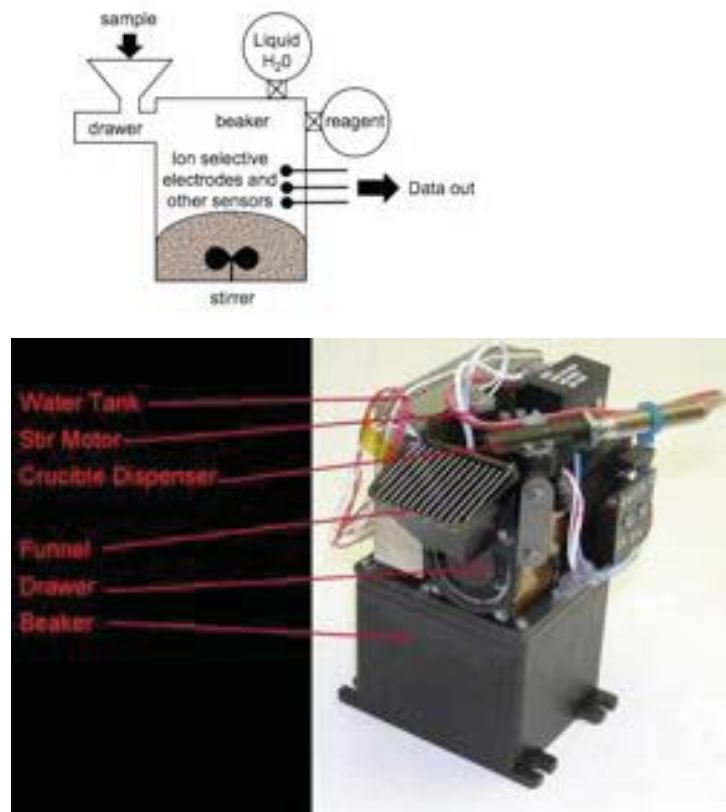

Figure 8. Diagram showing the drill within the biobarrier and how it is arranged on the Phoenix lander. The Figure also shows how the drill is deployed and the biobarrier ejected.

