

NASA/TP—2014-217906



Analysis of Space Station Centrifuge Rotor Bearing Systems: A Case Study

Joseph V. Poplawski
J.V. Poplawski & Associates, Bethlehem, Pennsylvania

Stuart H. Loewenthal
S.H. Loewenthal & Associates, San Jose, California

Fred B. Oswald, Erwin V. Zaretsky, Wilfredo Morales, and Kenneth W. Street, Jr.
Glenn Research Center, Cleveland, Ohio

NASA STI Program . . . in Profile

Since its founding, NASA has been dedicated to the advancement of aeronautics and space science. The NASA Scientific and Technical Information (STI) program plays a key part in helping NASA maintain this important role.

The NASA STI Program operates under the auspices of the Agency Chief Information Officer. It collects, organizes, provides for archiving, and disseminates NASA's STI. The NASA STI program provides access to the NASA Aeronautics and Space Database and its public interface, the NASA Technical Reports Server, thus providing one of the largest collections of aeronautical and space science STI in the world. Results are published in both non-NASA channels and by NASA in the NASA STI Report Series, which includes the following report types:

- **TECHNICAL PUBLICATION.** Reports of completed research or a major significant phase of research that present the results of NASA programs and include extensive data or theoretical analysis. Includes compilations of significant scientific and technical data and information deemed to be of continuing reference value. NASA counterpart of peer-reviewed formal professional papers but has less stringent limitations on manuscript length and extent of graphic presentations.
- **TECHNICAL MEMORANDUM.** Scientific and technical findings that are preliminary or of specialized interest, e.g., quick release reports, working papers, and bibliographies that contain minimal annotation. Does not contain extensive analysis.
- **CONTRACTOR REPORT.** Scientific and technical findings by NASA-sponsored contractors and grantees.

- **CONFERENCE PUBLICATION.** Collected papers from scientific and technical conferences, symposia, seminars, or other meetings sponsored or cosponsored by NASA.
- **SPECIAL PUBLICATION.** Scientific, technical, or historical information from NASA programs, projects, and missions, often concerned with subjects having substantial public interest.
- **TECHNICAL TRANSLATION.** English-language translations of foreign scientific and technical material pertinent to NASA's mission.

Specialized services also include creating custom thesauri, building customized databases, organizing and publishing research results.

For more information about the NASA STI program, see the following:

- Access the NASA STI program home page at <http://www.sti.nasa.gov>
- E-mail your question to help@sti.nasa.gov
- Fax your question to the NASA STI Information Desk at 443-757-5803
- Phone the NASA STI Information Desk at 443-757-5802
- Write to:
STI Information Desk
NASA Center for AeroSpace Information
7115 Standard Drive
Hanover, MD 21076-1320

NASA/TP—2014-217906



Analysis of Space Station Centrifuge Rotor Bearing Systems: A Case Study

*Joseph V. Poplawski
J.V. Poplawski & Associates, Bethlehem, Pennsylvania*

*Stuart H. Loewenthal
S.H. Loewenthal & Associates, San Jose, California*

*Fred B. Oswald, Erwin V. Zaretsky, Wilfredo Morales, and Kenneth W. Street, Jr.
Glenn Research Center, Cleveland, Ohio*

National Aeronautics and
Space Administration

Glenn Research Center
Cleveland, Ohio 44135

January 2014

Acknowledgments

The authors greatly appreciate discussions with Keith Campbell of Castrol Industries on the properties of PFPAE fluids and the product literature on Brayco 815Z oil.

We would like to acknowledge the valuable contributions of Roy W. Hampton, Structural Analysis and Verification Group Leader, Mechanical Systems and Materials Branch, NASA Ames Research Center, Moffett Field, CA, until his retirement in January 2006. Mr. Hampton was the catalyst for the formation of the NASA bearing team and the analysis presented herein. He was the person the team went to for all technical information and questions. He coordinated exchanges of data between the Japan Aerospace Exploration Agency (JAXA), Toshiba, and the NASA bearing team until the program was cancelled by NASA Headquarters in October 2005. Hampton is currently an independent consultant, Owl Analytics, LLC, Cupertino, CA.

Level of Review: This material has been technically reviewed by expert reviewer(s).

Available from

NASA Center for Aerospace Information
7115 Standard Drive
Hanover, MD 21076-1320

National Technical Information Service
5301 Shawnee Road
Alexandria, VA 22312

Available electronically at <http://www.sti.nasa.gov>

Contents

Summary.....	1
Introduction	1
Nomenclature	2
Background.....	2
Technical Information	2
Analysis and Discussion.....	6
Grease Lubricant	6
Rotating Shaft Assembly Rotor Bearing System.....	6
Spin Motor Encoder With Steel Shaft	9
DB Preloaded Bearing Arrangement.....	10
Induced Thrust Due to Shaft Interference Fit.....	11
Effects of Bearing Operating Temperature	12
Effects of Bearing Temperature Gradient	12
Bearing Assembly L_1 Fatigue Life	13
Bearing Seizure Tests.....	13
Summary of Results.....	14
Epilogue.....	15
Appendix—Braycote 601 Grease	17
References	19

Analysis of Space Station Centrifuge Rotor Bearing Systems: A Case Study

Joseph V. Poplawski
J.V. Poplawski & Associates
Bethlehem, Pennsylvania 18018

Stuart H. Loewenthal
S.H. Loewenthal & Associates
San Jose, California 95127

Fred B. Oswald, Erwin V. Zaretsky, Wilfredo Morales, and Kenneth W. Street, Jr.
National Aeronautics and Space Administration
Glenn Research Center
Cleveland, Ohio 44135

Summary

A team of NASA bearing and lubrication experts was assembled to assess the risk for the rolling-element bearings used in the International Space Station (ISS) centrifuge rotor (CR) to seize or otherwise fail to survive for the required 10-year operational life. The CR was designed by the Japan Aerospace Exploration Agency and their subcontractor, NEC Toshiba Space Systems, Ltd. (NTSpace). The NASA team performed a design audit for the most critical rolling-element bearing systems and reviewed the lubricant selected. There is uncertainty regarding the ability of the Braycote 601 grease (Castrol Limited) to reliably provide the 10-year continuous life required without relubrication of the system. Without test data available for evaluation, grease endurance tests are required to confirm mission requirements for grease life. The fatigue life of the Rotor Shaft Assembly (RSA) spring preloaded face-to-face mount at a 99-percent probability of survival (L_1 life) for the ball bearing set was estimated at 700 million hours and the single ball bearing (Row 3) at 58 million hours. These lives satisfy the mission requirements for fatigue. However, this does not mean that the grease life will meet mission requirements without the need to relubricate the bearings. NTSpace conducted rolling-element bearing jamming tests on the RSA and fluid slip joint bearings. These bearings were found unlikely to suddenly stop the centrifuge, which can cause potential damage to the ISS structure. However, the spin motor encoder duplex angular-contact ball bearings, which have a hard preload and a large number of small bearing balls, were not tested for seizure even though they are less tolerant to debris or internal clearance reductions. Of the rolling-element bearing designs evaluated by the team, this is the one at highest risk of failure and, accordingly, should be tested for seizure.

Introduction

The Centrifuge Accommodations Module (CAM), designed by the Japan Aerospace Exploration Agency (JAXA) and their subcontractor NEC Toshiba Space Systems, Ltd. (NTSpace), was proposed as a laboratory for conducting gravitational biology research in the International Space Station (ISS). It is a pressurized module equipped with the Life Sciences Glove Box, a centrifuge rotor (CR), habitat holding racks, a freezer rack, and storage racks. The Life Sciences Glove Box was to provide an environment in which biological specimens and chemicals would be isolated from the pressurized environment of the module. Crew members would manipulate those specimens through gloves (Ref. 1).

The CR is a laboratory that provides a selectable, simulated gravity for biological specimens. The CAM flight module and the engineering model of the CR had been built by the time of the analysis described in the paper. Ownership of the CAM would belong to NASA in exchange for a free launch of the Japanese Experiment Module (Kibo) (Refs. 1 and 2).

Original plans were to deliver the Life Sciences Glove Box to orbit in 2004 by a U.S. space shuttle. In 2006 the CAM and CR were to be delivered in orbit by a U.S. space shuttle. The CAM was to be attached to the Harmony module of the ISS (Ref. 2).

The U.S. portion of the program was the responsibility of the NASA Ames Research Center. However, in 2003 several program and technical issues became apparent that would affect the future of the CAM: First, the program was behind schedule. Second, considering the loss of the Space Shuttle *Columbia*, there was an issue regarding the remaining space shuttle flights available for CAM delivery to the ISS. Third, there was an issue regarding the ability of NASA to fulfill other remaining commitments to the ISS before the retirement

of the space shuttle fleet then scheduled for 2010. Fourth, there was an issue regarding the risk for the rolling-element bearings used in the ISS CR to seize or otherwise fail to survive for the required 10-year operational life.

The mechanical design of the CAM that evolved from JAXA contained four rotor-bearing systems having a total of 10 rolling-element bearings. These bearings were to be lubricated with Braycote 601 EF (Castrol Limited), a perfluoropolyalkyl ether (PFPAE) bearing grease. Bearing bore sizes would range from 30 to 240 mm, and the maximum rotor speed was given as 42 rpm. Bearing operating temperatures were about in the range of 50 °C (122 °F).

In February 2003, Roy W. Hampton of NASA Ames requested Erwin V. Zaretsky of NASA Glenn Research Center to help assess the potential risk that one of the bearings for the ISS CR would seize or fail. A team comprising the authors of this paper was organized to bring together experts from NASA Glenn Research Center and from industry. The NASA bearing team was charged with performing a design audit for the most critical bearing systems and reviewing the lubricant selected.

The objective of this report is to document and summarize the team's analysis, findings, conclusions, and recommendations regarding the viability of the CR bearing system as designed in 2003. In addition, the paper serves as a case study and an example of the procedures required to analyze the performance, life, and reliability of a complex bearing system. Technical information is presented followed by a discussion of the lubricating grease and the major bearing systems.

Nomenclature

BFA	body flap actuator
CAM	Centrifuge Accommodations Module
CR	centrifuge rotor
DB	back-to-back bearing configuration
DF	face-to-face bearing configuration
EHD	elastohydrodynamic
FSJ	fluid slip joint
FTIR	Fourier transform infrared
JAXA	Japan Aerospace Exploration Agency
ICP	inductively couple plasma
ISS	International Space Station
L_1	life at 99-percent probability of survival
MAC	multiply alkylated cyclopentane
NTSpace	NEC Toshiba Space Systems, Ltd.
PFPAE	perfluoropolyalkyl ether
PTFE	polytetrafluoroethylene
RSA	Rotor Shaft Assembly
RSB	rudder speed brake
SEC	size exclusion chromatography
SME	spin motor encoder
SOT	spiral orbit tribometry
SRA	slip ring assembly

Background

The team gathered all pertinent drawings, bearing data, operating loads and speeds, grease information, and operating environment data required for review. They constructed analysis models of each of the shaft systems using rolling-element bearing analysis software and performed fit-up analysis on all bearings using classical methods. They used an integrated analysis code with finite-element models (Ref. 3) for each bearing location to quantify bearing load reactions, internal load distributions, Hertz contact stresses, shoulder height requirements, heat generation, film thickness, life factors, and other information reflective of bearing performance. The team conducted thermal and dimensional interaction analysis at each bearing location to estimate bearing inner-race, rolling-element, and outer-race operating temperatures and to assess thermal stability of the individual bearings.

The bearing team was also charged with reviewing the use of other grease types and suggesting alternate greases to the Braycote 601 PFPAE grease selected by JAXA. They performed calculations and recommended testing to quantify grease life. The team conducted thermal-dimensional interaction analysis at each bearing location to estimate bearing inner-race, rolling-element, and outer-race operating temperatures and assess thermal stability of the individual bearings.

A series of Technical Interchange Meetings were held with JAXA and their subcontractor NTSpace. The first meeting attended by the team was held on December 11 and 12, 2003. During this and subsequent meetings, JAXA and NTSpace reviewed progress on their design, analyses, test plans, and current test results regarding the CR bearings. Many of the findings, conclusions, and recommendations of the team regarding the viability of the bearing system were presented at the meetings held with JAXA and NTSpace or in correspondence with both JAXA and NASA management.

Technical Information

The centrifuge comprises a 2.5-m- (8.2-ft-) diameter wheel having a rotating mass of 1220 kg (2700 lb) rotating at speeds to 42 rpm. In space it would simulate a range of artificial gravity environments from zero up to 2g. Because of this large rotating inertia, sudden bearing failure could be catastrophically hazardous to the ISS if one or more of the bearings were to suddenly seize, with the potential of causing structural damage to the ISS. Furthermore, there were no maintenance provisions to replace the rotor or motor encoder bearings during the planned 10-year mission life at an assumed 50-percent duty cycle (43 680 h). Therefore, longevity was of great concern.

Figure 1 shows a cross section of the centrifuge assembly with the major bearing groups identified. The Rotor Shaft

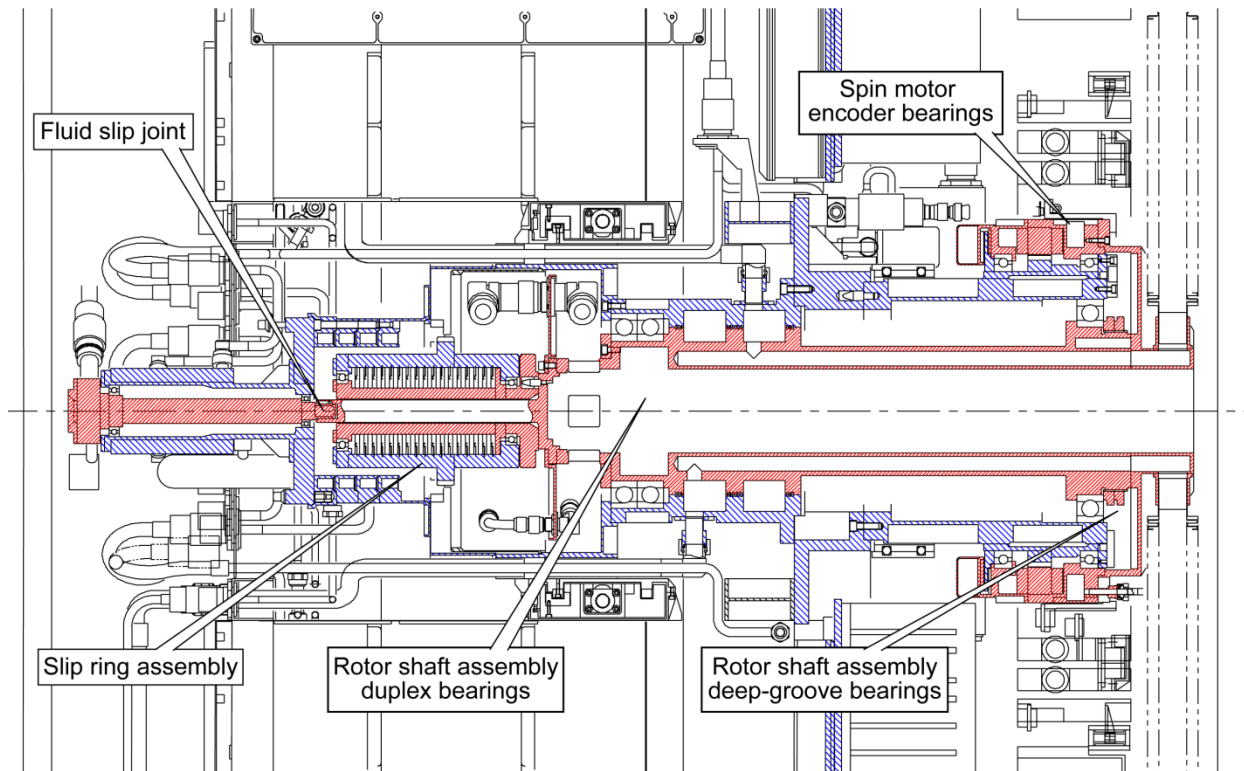

Figure 1.—International Space Station centrifuge rotor showing bearing locations.

Assembly (RSA) bearings support the main rotor of the centrifuge. The spin motor encoder (SME) bearings support the motor-encoder assembly. The slip ring assembly (SRA) and the fluid slip joint bearings are not reviewed in this report because JAXA did not provide the required information for an engineering analysis.

The RSA bearings as well as the SME bearings are large in diameter (>280 mm outside diameter for RSA and 457 mm for SME) and could cause a catastrophic failure if they seized suddenly. At the very least, the operation of the CR would be suspended because bearing replacement in space would be difficult if not impractical.

The SME bearings are thin-section angular-contact ball bearings mounted in a back-to-back (DB) configuration under hard preload. The RSA bearings (Fig. 2) consist of a set of face-to-face (DF), spring-preloaded, duplex angular-contact ball bearings on one side and a spring-loaded deep-groove ball bearing on the other side.

Both sets of bearings are mounted in an aluminum structure, except the SME bearings have a steel shaft. The bearing fit-ups will change significantly at the expected 50 °C (122 °F) operating temperature because of the much higher coefficient of thermal expansion of the aluminum mount relative to the

steel bearings. For the RSA bearings, the loose outer-ring fits and spring preload will tend to reduce the thermal increase in bearing internal load. However, the SME bearing is hard preloaded and is significantly more sensitive to thermal effects.

JAXA did not furnish to NASA the complete bearing mounting, fit, or other key bearing parameters that were needed by the NASA bearing team for the bearing audit detailed calculations. Those parameters used by the NASA bearing team are shown in Table I.

JAXA selected Braycote 601 grease, which contains 815Z oil, to lubricate all the bearings in the system. Published investigations at the time suggest that bearing life is limited with PFPAE greases such as Braycote 601. This grease is known to break down under continuous cycling. It was the opinion of the NASA bearing team that this grease would not reliably provide the 10-year life required (at 50 percent duty cycle) without relubrication of the system. There are no provisions for relubrication during this time. The degree of risk is uncertain. JAXA/NTSpace did not provide RSA or SME bearing life test data for our evaluation. (See the appendix regarding subsequent reported work regarding Braycote 601 grease and 815Z oil.)

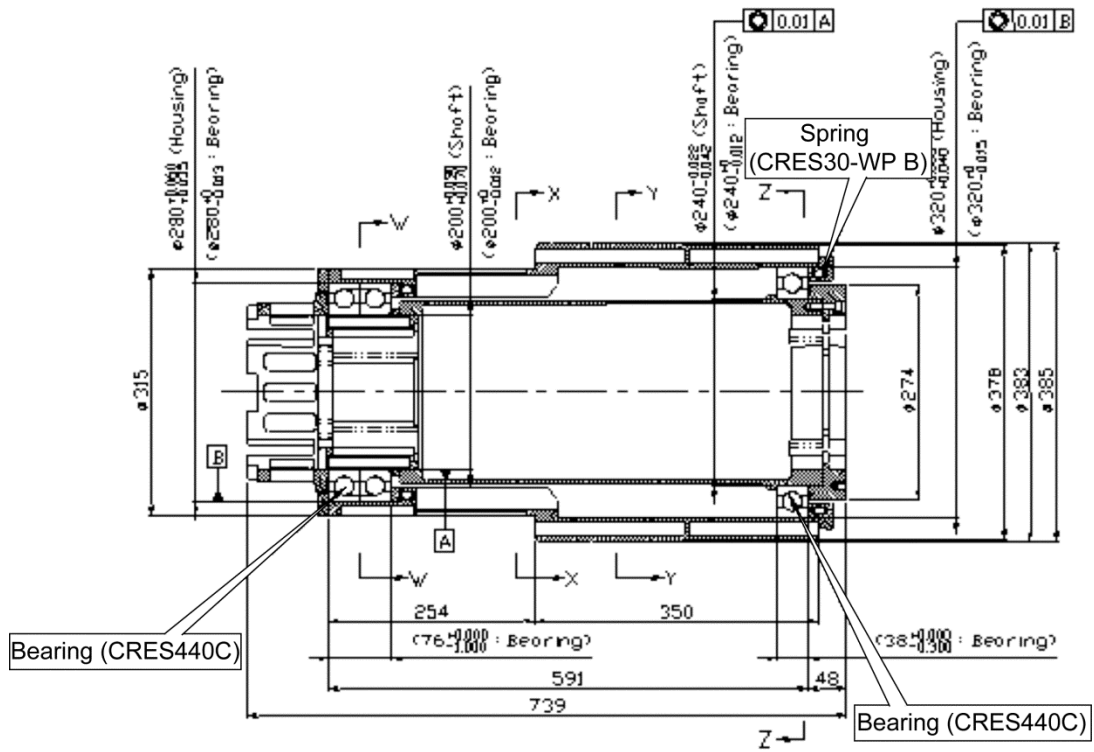

Figure 2.—Rotor Shaft Assembly main bearing details. Housing and shaft are Aluminum 7075-T73. Duplex angular-contact and deep-groove ball bearings are spring preloaded.

TABLE 1.—ROTOR SHAFT ASSEMBLY AND SPIN MOTOR ENCODER BEARING PARAMETERS

Item	Centrifuge bearing system		Spin motor encoder assembly ^a
	Angular contact	Deep groove	Angular contact
Bearing envelope size ^b	$D = 280 - 0.013/0$ mm $d = 200 - 0.012/0$ mm $B = 38$ (Duplex = $76 - 1.000/0$) mm	$D = 320 - 0.015/0$ mm $d = 240 - 0.012/0$ mm $B = 38 - 0.300/0$ mm	$D = 18.000 - 0.0006/0$ in. $d = 16.000 - 0.0006/0$ in. $B = 1.000$ (Duplex = $2.000 - 0.050/0$) in.
Drawing and part number	Part no.: US-200BA19A-H-TZSDFCA150P4AU59U76U 118A BCEX	Part no.: US-B240-15-H-TZZSCG93P4AU59U76U 118A BCEX	Drawing no.: PIN 12516 SCD
Vendor	NSK	NSK	KAYDON
Specify commercially available or special design and manufacture of commercial design application	Special design	Special design	Special design
Tolerance class	ABEC-7	ABEC-7	ABEC-5
Material	SUS440C	SUS440C	AISI440C
Shaft fit	200 diam. +0.070/+0.090 mm	240 diam. -0.042/-0.022 mm	Under coordination for disclosure
Housing fit	280 diam. +0.035/+0.060 mm	320 diam. +0.040/+0.065 mm	Under coordination for disclosure
Preload	588 N, 1177 N	58 N	1223.26 N
Radial capacity Static, Co Dynamic, Cr	270 000 N 168 000 N	120 000 N 94 000 N	No data
Ball diameter and number	19050 mm diam. 30 balls	19.050 mm diam. 24 balls	0.500 in. diam. No number data
Pitch diameter	240 mm	280 mm	17.0 in.
Contact angle	25°	No data	30°
Free-state internal diametrical clearance	0.176 to 0.196 mm	0.088 to 0.108 mm	No data
Inner/outer raceway curvature	10.096 mm	10.096 mm	0.2650 in.
Inner/outer raceway surface finish	0.15 μm	0.15 μm	0.15 μm
Ball surface finish	0.10 μm	0.1 μm	ABMA Standard section 10, grade 5
Race shoulder heights Inner Outer	No data	No data	425.25 mm 438.35 mm
Anticipated inner-race temperature	50 °C	50 °C	50 °C
Anticipated outer-race temperature	50 °C	50 °C	50 °C
Anticipated shaft temperature	50 °C	50 °C	50 °C
Anticipated housing temperature	50 °C	50 °C	50 °C
Cage geometry ^b	$D = 246.7$ mm $d = 231.4$ mm $B = 31$ mm	$D = 287.9$ mm $d = 270.77$ mm $B = 29.5$ mm	No data
Cage pilot and pocket clearances	No data	No data	No data
Cage material	Phenolic resin cotton weave	Phenolic resin cotton weave	Phenolic resin cotton weave

^aDimensions for this bearing were provided in inches by bearing manufacturer.

^b D is outside diameter, d is bore diameter, and B is bearing width.

Analysis and Discussion

A team of NASA bearing and lubrication experts was assembled to assess the risk for the rolling-element bearings used in the ISS CR to seize or otherwise fail to survive for the required 10-year operational life. The CR was designed by JAXA and their subcontractor, NTSpace. The NASA team performed a design audit for the most critical rolling-element bearing systems and reviewed the lubricant selected.

Grease Lubricant

JAXA and NTSpace selected Braycote 601 grease to lubricate the rolling-element bearings of a CR that was to be mounted aboard the ISS. The CR was designed to operate under various conditions for 10 years. There were no provisions to inspect and regrease the bearings during the 10-year operational period.

Braycote 601 grease consists of Bray 815Z oil, which is PFPAE oil, dispersed in a Teflon thickener. Small quantities of bentonite clay containing sodium nitrite are also dispersed in the thickener to enhance anticorrosion properties. The ball bearings are manufactured from AISI 440C stainless steel.

Braycote 601 grease is space qualified. It has been used in numerous satellites, the space shuttles, and the ISS. The PFPAE base oil has a vapor pressure about 10^{-10} torr (10^{-3} atm) at 20 °C (68 °F) (Ref. 4). This property is one of the primary reasons that Braycote 601 EF was space qualified by NASA. Since the CR would not operate in vacuum, the low vapor pressure property was not needed. PFPAE oils, however, suffer from a number of limitations.

Compared with hydrocarbon-based oils, PFPAE oils are poor boundary lubricants. This is a particular concern for the SME bearings, which were expected to operate in the boundary lubrication regime because of the high loads. With boundary lubrication, excessive wear is a particular concern (Ref. 5).

Because of their perfluorinated chemistry, PFPAE oils will not dissolve antiwear and extreme pressure additives (Ref. 6). Without these additives, even hydrocarbon oils operating under boundary lubricating conditions will provide very poor lubrication. Under certain boundary lubricating conditions, PFPAE-based oils have been shown to degrade. Under low-speed conditions, such as those found in certain satellites, PFPAE oil degrades, over a period of several years, leading to the formation of a highly viscous substance that impedes bearing performance (Ref. 5).

The relationship between lubricant lifetime and bearing load has been established by spiral orbit tribometry (SOT) experiments (Ref. 7). The SOT lifetime was determined for several lubricating oils, including Z-25, a PFPAE similar to 815Z, in the range of 1.0 to 2.0 GPa (145 to 290 ksi) mean Hertzian stress. This study indicated exponential degradation

of lubricant with increasing stress for all oils tested. This test range is within the stress range calculated for some of the CR bearings under certain operating conditions. This brings to question whether this lubricant lifetime will be drastically lowered during times of high stress, particularly for PFPAE oils, which typically have considerably shorter lifetimes than hydrocarbon-based oils under normal load conditions.

Rolling-element bearings in the ISS Treadmill with Vibration Isolation and Stabilization system had failed prior to the work reported herein. The ISS treadmill bearings were off-the-shelf items, where the original vendor grease was removed and replaced with Braycote 601 grease. The bearings operated at room temperature in a humid air atmosphere similar to that expected for the CR bearings. The treadmill bearings failed after approximately 1000 h of use. It was concluded that the bearings were “inadequately lubricated by the Braycote 601 grease” (Ref. 8, internal presentation).

The NASA bearing team recommended that consideration be given to substituting the Braycote 601 with Pennzane-based grease containing multiply-alkylated-cyclopentane-based oil (MAC 2001A). Component and full-scale bearing tests show 10 to 100 times life advantage for Pennzane (Refs. 9 and 10). Many space companies currently are using or moving to Pennzane. However, it was not clear whether there would be sufficient time to switch to Pennzane given the long lead times and the late start on the life tests and their long duration. (See the appendix regarding subsequent reported work regarding Braycote 601 grease and 815Z oil.)

Because of probable limitations of grease life, it was a recommendation of the team to schedule the important artificial gravity experiments early in the mission and manage the number of stops and starts and bearing revolutions in order to prolong the CR life. It was the opinion of the NASA bearing team that this grease would not reliably provide the 10-year continuous life required without relubrication of the system.

Rotating Shaft Assembly Rotor Bearing System

In the main Rotor Shaft Assembly (RSA) the shaft is stationary and the “housing” is rotating. Therefore, the rolling-element bearings will exhibit outer-race rotation. The bearings are made from AISI 440C stainless steel, and both the shaft and housing are made from 7075-T73 aluminum. The inner rings of the duplex set are interference fit onto the shaft with a shaft fit of -0.070 to -0.102 mm T (-0.00276 to -0.0040 in. T) at assembly. The single spring-loaded, Conrad radial ball bearing has a shaft fit of 0.010 to 0.042 mm L (0.00039 to 0.00165 in. L). The initial JAXA drawings showed the bearings DB mounted. In a subsequent drawing received from JAXA, the set was drawn with a DF mount.

The raceway surface finishes were given as 0.15 μm (6 μin) Ra and the ball at 0.10 μm (4 μin) Ra. (It is our opinion that

the ball finish is in error (typo) and should be 0.01 μm (0.4 μin) Ra.) The spring preload was stated as 588 N (133 lbf) for the single Conrad (deep-groove) ball bearing and 1177 N (265 lbf) preload thrust for the DF set.

JAXA estimated the bearings will operate at 50 °C (122 °F). The bearings will be prepacked with Braycote 601 PFPAGE grease. The bearing cages or separators are made from phenolic resin and are assumed to be inner-land riding because no bearing drawings with cage definition were provided. One of the main design concerns with this system was the mounting of the steel inner rings of the duplex set onto an aluminum shaft with an interference fit. The expansion rate of aluminum is double that of steel. This will potentially cause a high induced preload into the set as the unit stabilizes at the 50 °C (122 °F) operating temperature level.

The buildup of preload thrust with decreasing bearing clearance is inherent in the standard DB and DF mounts. This especially occurs in systems that have an interference fit on the shaft with a shaft material that thermally expands faster than the bearing ring material. Spring preload of bearing sets typically gives a system that has significantly lower sensitivity to clearance reduction. (We assumed that is the reason why JAXA eventually went to this type of arrangement.) In the spring preload arrangement, the outer ring of the single radial ball bearing is spring loaded with 588 N (132.3 lbf), and the outer ring of the inboard bearing in the DF set is also spring loaded with 588 N (132.3 lbf). This arrangement results in 1177 N (265 lbf) load in Row 1 of the DF set; 588 N (132.3 lbf) in the inboard Row 2 of the DF set; and 588 N (132.3 lbf) in the single radial ball bearing Row 3. (Row 1 is the left most bearing of the DF set of the CR; Row 2 is the companion bearing of the DF set; and the single spring-loaded radial bearing is Row 3.)

In a spring-preloaded system, the thrust load in each bearing row will remain essentially constant because of the ability of the mount to offset any decrease in radial clearance with an axial shift against the spring. The clearance reduction, however, will alter the contact angles in the bearing rows.

Figure 3 shows the change of operating contact angles within the three bearing rows of the spring-preloaded DF set as the bearing operating temperature is increased. These results show that the contact angles in Rows 1 and 2 of the DF set change from the original 25° (unmounted) to about 23.8° after mounting. The angle further slightly reduces to 22° at the 50 °C (122 °F) operating temperature. However, in Row 3 (single ball bearing), the operating contact angle reduces to 12° from a free-state value of 16.7° nominal. Radial ball bearings typically develop a contact angle in the range of 8° to 15°. As the contact angle decreases, the stress level increases and the life decreases for the same thrust load.

The expected failure mode of the CR bearings due to lubricant degradation is either a significant torque increase or rough running that would upset microgravity requirements.

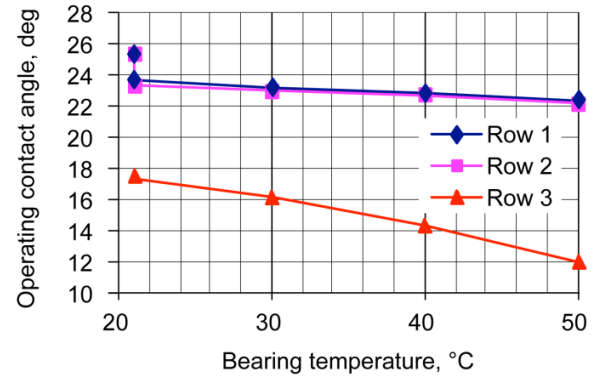

Figure 3.—Effect of bearing temperature on contact angle for bearing rows in Rotor Shaft Assembly (RSA) with 42-rpm spring-preloaded face-to-face (DF) bearing set.

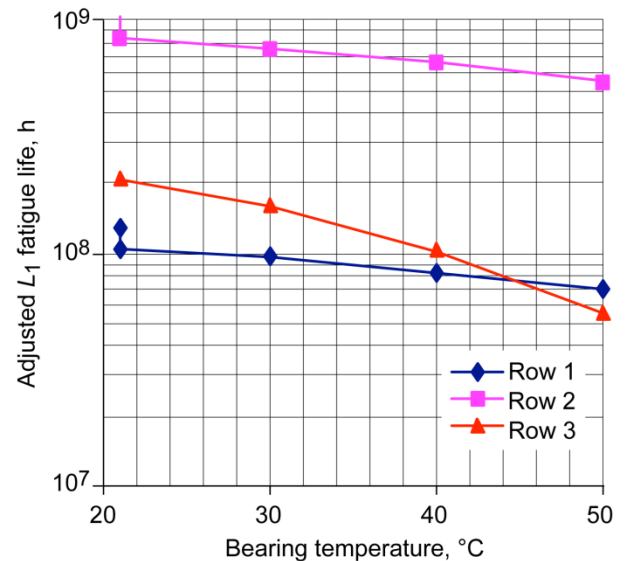

Figure 4.—Adjusted L_1 fatigue life versus bearing temperature for bearing rows in Rotor Shaft Assembly (RSA) with 42-rpm spring-preloaded face-to-face (DF) bearing set.

One means to arrive at an estimate of lubricant life is to calculate the product of ball pass times Hertz stress to compare with similar calculations from life test data.

Although fatigue life calculations are not directly relevant to this type of failure mode, calculations at the L_1 life (99 percent probability of survival) level can provide for relative life values. The adjusted L_1 fatigue life for each bearing row as a function of bearing operating temperature is shown in Figure 4.

The calculation included a life (adjustment) factor of 0.6 for the AISI 440C steel compared to the standard AISI 52100 bearing steel in addition to a life factor for lubrication. This means the life for AISI 440C steel is only 60 percent of the life for AISI 52100 steel. At the 50 °C (122 °F) operating

temperature, the L_1 fatigue life for the bearing Rows 1, 2, and 3 are 70 million, 65 million, and 58 million hours, respectively. These lives satisfy mission requirements. It can be reasonably concluded that rolling-element fatigue would not be a life-limiting failure mode for this design.

JAXA estimated that the bearings could develop a 5 to 15 °C (9 to 27 °F) temperature gradient between the inner and outer race during operation. Therefore, the effect of temperature on bearing performance was evaluated at 30 and 50 °C (85 and 122 °F) outer-race temperatures with gradients ranging up to 30 °C (54 °F), where the inner race operates at a higher temperature than the outer race.

Figure 5 shows the influence of temperature gradient across the bearing on the operating contact angle for a 30 °C (85 °F) outer-race temperature. The contact angles in Rows 1 and 2 of the set decrease from about 22.5° for 0 °C gradients down to about 19.5° at a 15 °C (27 °F) gradient. The Row 3 contact angle reduces from 16° down to approximately 6.5° at 15 °C (27 °F) gradient. This is a very low contact angle for a thrust-loaded bearing. If gradients should be larger than 15 °C (27 °F), Row 3 will become a critical concern.

Figure 6 shows the Hertz stress changes as the bearing temperature gradient increases at the 30 °C (85 °F) outer-race temperature. The maximum Hertz contact stress for Rows 1 and 2 of the DF set show a minor increase for the 15 °C (27 °F) gradient. However the single-ball-bearing Row 3 has stresses increasing from about 640 MPa (92 800 psi) to 1000 MPa (145 000 psi) at the 15 °C (27 °F) gradient.

Although this stress level is not severe, stresses can begin to significantly increase if temperature gradients begin to move into the range of 25 to 30 °C (45 to 54 °F). At a 30 °C (54 °F) gradient, the Hertz stress approaches 2200 MPa (319 000 psi), a level that is excessive for this application and particularly for PFPFAE lubricants (Ref. 6), which form degrading Lewis acids

even under moderate sliding and moderate stress conditions (Ref. 11). Specific RSA and SME bearing life test data under the specific operating conditions (e.g., speeds, temperatures, and in air) are required to establish the degree of risk.

The adjusted L_1 fatigue life for different temperature gradients at 30 °C (85 °F) outer-race temperature is shown in Figure 7. This analysis shows the potential degradation of the life of the single ball bearing Row 3 at the higher temperature gradients. Going to a C4 clearance in the bearing to create a higher initial contact angle may minimize these effects.

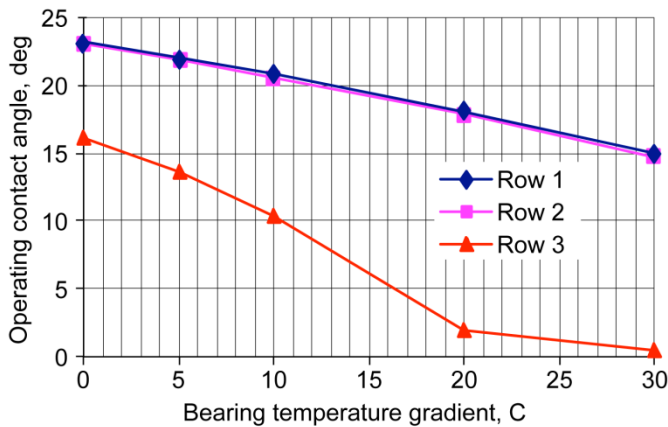

Figure 5.—Contact angle versus bearing temperature gradient for bearing rows in Rotor Shaft Assembly (RSA) with 42-rpm spring-preloaded face-to-face (DF) bearing set. Outer-race is temperature 30 °C, and inner-race temperature is higher.

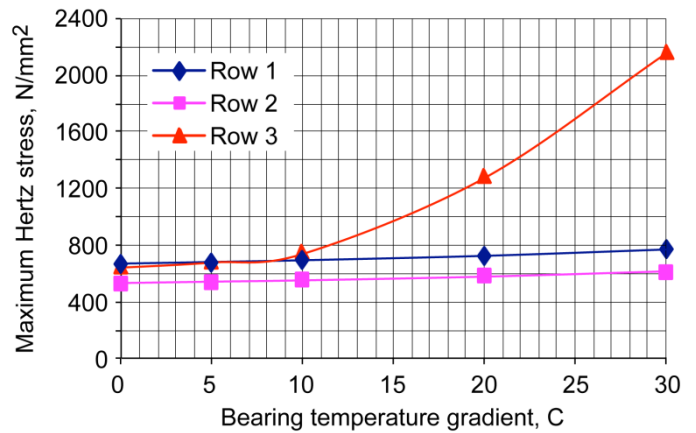

Figure 6.—Maximum Hertz stress versus temperature gradient for bearing rows in Rotor Shaft Assembly (RSA) with 42-rpm spring-preloaded face-to-face (DF) bearing set. Outer-race is temperature 30 °C, and inner-race temperature is higher.

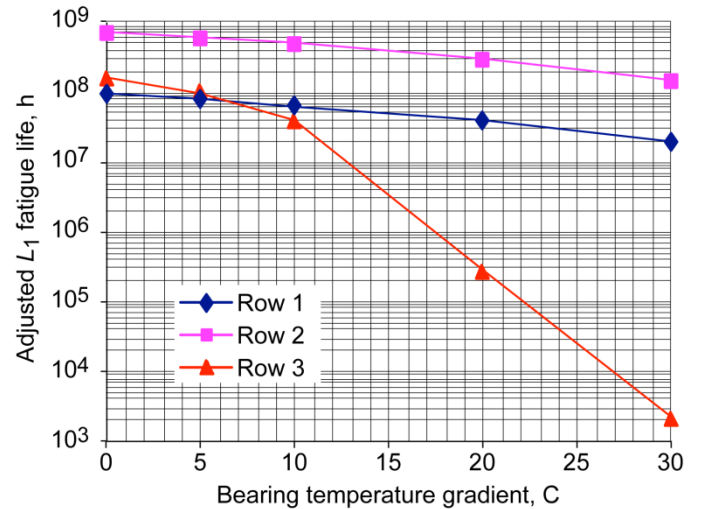

Figure 7.—Adjusted L_1 fatigue life versus temperature gradient for bearing rows in Rotor Shaft Assembly (RSA) with 42-rpm spring-preloaded face-to-face (DF) bearing set. Outer-race is temperature 50 °C, and inner-race temperature is higher.

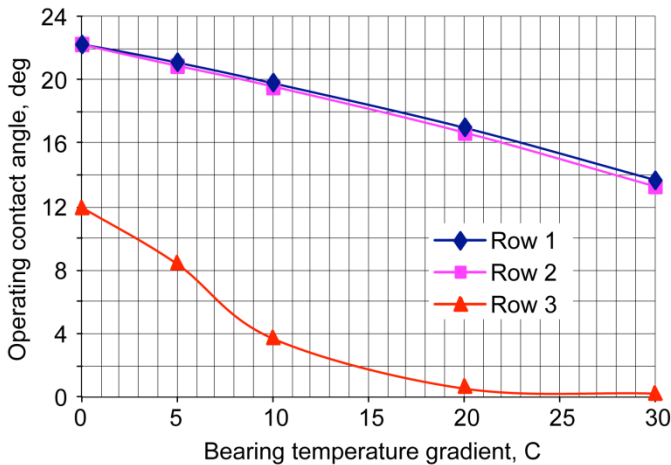

Figure 8.—Contact angle versus bearing temperature gradient for bearing rows in Rotor Shaft Assembly (RSA) with 42-rpm spring-preloaded face-to-face (DF) bearing set. Outer-race is temperature 30 °C, and inner-race temperature is higher.

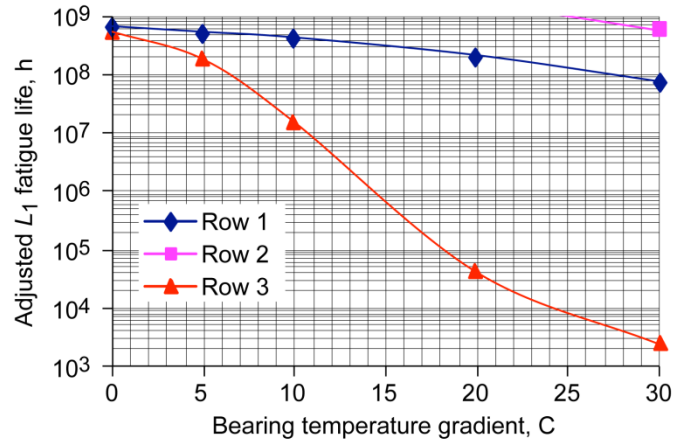

Figure 10.—Adjusted L_1 fatigue life versus temperature gradient for bearing rows in Rotor Shaft Assembly (RSA) with 42-rpm spring-preloaded face-to-face (DF) bearing set. Outer-race temperature is 50 °C, and inner-race temperature is higher.

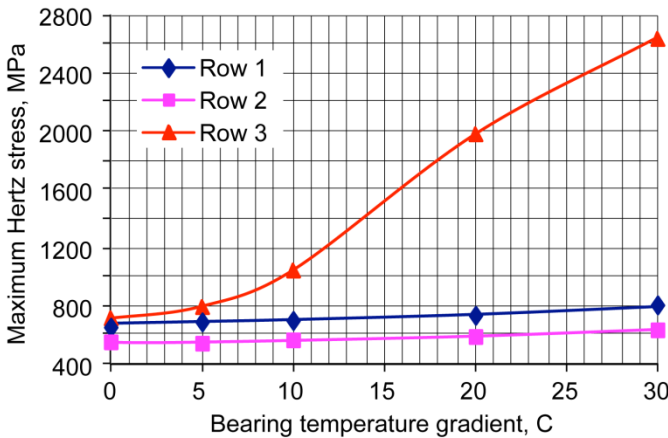

Figure 9.—Maximum Hertz stress versus temperature gradient for bearing rows in Rotor Shaft Assembly (RSA) with 42-rpm spring-preloaded face-to-face (DF) bearing set. Outer-race is 50 °C, and inner race is hotter.

Operating contact angle changes with bearing temperature gradient for a 50 °C (122 °F) outer-race temperature (Fig. 8). Once again there is a significant decrease in the contact angle for the single ball bearing Row 3 going from 12° at 0 °C (0 °F) gradient to about 1.8° at 15 °C (27 °F) gradient. This is a very low angle for a thrust-loaded bearing.

Figure 9 shows that there is an increase in maximum Hertz stress resulting from the contact angle change. The maximum Hertz contact stress in the single spring-preloaded ball bearing increases to 1500 MPa (217 500 psi) at a 15 °C (27 °F) gradient and 2600 MPa (377 000 psi) for a 30 °C (54 °F) gradient. These stress levels are larger than desired for this application. These higher Hertz stresses will cause a significant reduction in the fatigue life of the bearing.

There is a drastic reduction in adjusted L_1 fatigue life as bearing temperature gradient increases at a 50 °C (122 °F) outer-race temperature level as shown in Figure 10. Once again, the life of the single ball bearing Row 3 is drastically reduced to about 60 000 h at the 15 °C (27 °F) gradient from about 53 million h at 0 °C (0 °F) gradient.

The spring-preloaded bearing arrangement is typically much less sensitive to temperature and bearing thermal gradients that cause clearance change in the bearings. This was analytically confirmed for the DF Rows 1 and 2 of the set. However, the single radial bearing Row 3 showed degraded performance when inner- to outer-race temperature gradients approached 15 °C (27 °F) and larger. This results from the decrease in contact angle within that bearing as radial clearance is lost. Contact angles in Row 3 fell to as low as 2°, resulting in high Hertz contact stresses and significant life reduction.

Spin Motor Encoder With Steel Shaft

The two angular-contact ball bearings contained in the spin motor encoder (SME) are slim-line ball bearings. Slim-line bearings offer space savings over conventional ball bearings by utilizing a smaller radial cross section. Slim-line bearing races are less rigid than those in conventional designs. Their thin cross section with numerous small-diameter balls makes them extremely sensitive to temperature gradients and lubricant degradation debris. The original design showed the bearings to have a DB mount on an aluminum shaft with a solid preload. Subsequently, we were informed the bearings would have a DF mount. However, information presented at the March 2005 Technical Information Meeting indicates the arrangement was again DB and the shaft was steel.

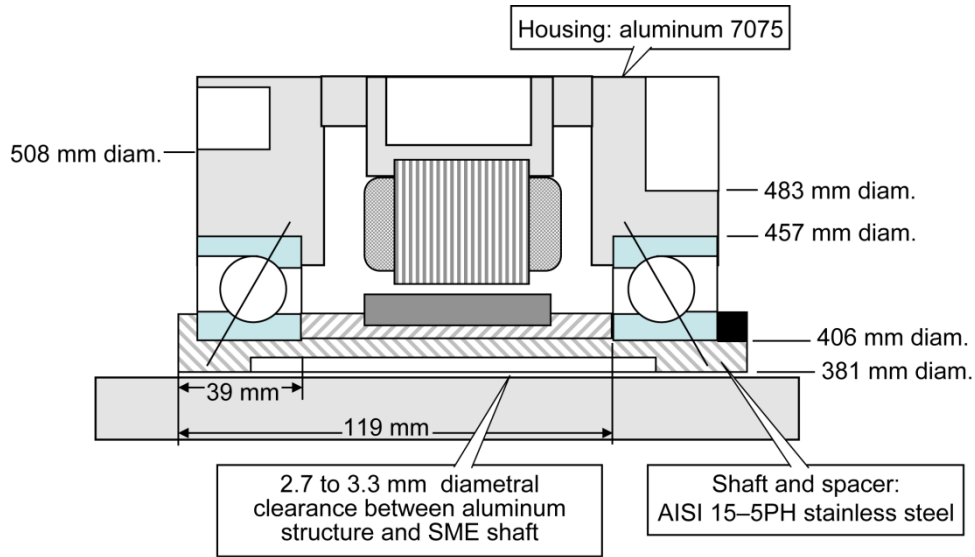

Figure 11.—Spin motor encoder (SME) bearing-shaft system.

DB Preloaded Bearing Arrangement

Figure 11 is a sketch by the NASA bearing team showing the SME configuration as then presented. The reported solid preload was 734 N (165 lbf). The AISI 440C stainless steel bearings are mounted onto the steel shaft with a -0.01524 to -0.04572 mm (-0.00060 to -0.00180 in.) interference fit. The housing fit was given as $+0.0991$ to $+0.1346$ mm ($+0.00390$ to $+0.00530$ in.) loose.

Figure 11 shows that the inner races of the left and right bearing are separated by a steel spacer whose length is approximately 80.3 mm (3.16 in.). When the bearings are manufactured there will be a gap between the two inner races if the bearings are held together without a spacer. The size of the gap will be that required to produce a 733-N (165-lbf) preload when the inner races are clamped together. The total (two bearings) preload gap for this unit is 0.0066 mm (0.00026 in.).

If there were no spacers between the bearings, they would touch at the outer races but have a 0.0066-mm (0.00026-in.) gap between the inner races. When the stack-up is compressed, the gap will disappear and show up as an axial deflection within the bearing giving the 733-N (165-lbf) preload. However, if there are spacers as in the design, the tolerance or net error in spacer length due to manufacturing tolerances of adjacent parts of the stack-up, bolt compression, and different axial stiffness will interact with the preload developed in the bearing set.

Figure 12 shows an exaggerated net error whereby the inner spacer falls short of the required match length. As the stack-up is compressed, the bearings will undergo the compression required for the preload (0.0066 mm) (0.00026 in.) and

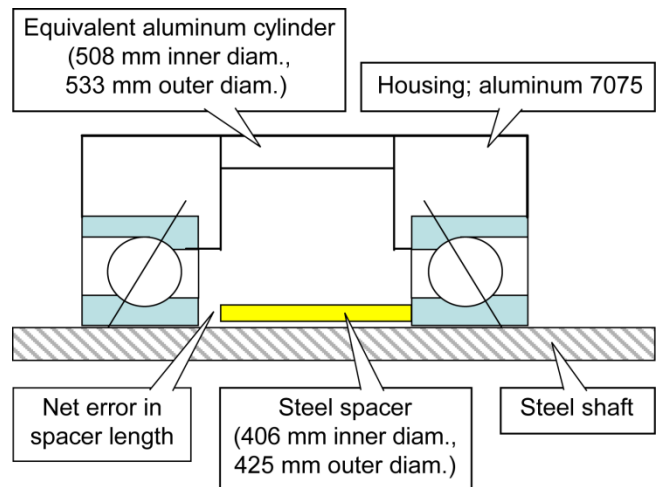

Figure 12.—Back-to-back (DB) bearing mounting within the spin motor encoder (SME).

continue to be axially deflected until the total gap space is depleted. For our example, the bearing will wind up with a preload greater than the target value of 733 N (165 lbf). If the spacer error results in a “longer” spacer, clamping of the stack-up will result in a lower preload than desired because the inner races will not undergo the full 0.0066-mm (0.00026-in.) compression. As in any spring network, most of the deflection will be absorbed into the softer springs.

An approximate model of the system was constructed in order to get a feel for the sensitivity of the change in design preload due to net spacer length error. The shaft and housing fits are set at 0.000 mm (a line-to-line fit). The axial stiffness

of the aluminum equivalent cylinder was estimated at 28 200 000 N/mm (161 000 000 lbf/in.) and that of the inner spacer at 31 700 000 N/mm (181 200 000 lbf/in.). In contrast, the bearing row axial stiffness varies between 180 000 N/mm (1 030 000 lbf/in.) at 111 N (25 lbf) thrust to 460 000 N/mm (2 620 000 lbf/in.) at 1778 N (400 lbf) thrust load. Therefore, the spacers are 80 to 90 times stiffer than the bearing, and only about 1 percent of the net spacer length error would be absorbed into the spacers and 99 percent into the bearings. In this study, we assumed that 100 percent of the error would occur in the bearings.

The bearing analysis program (Ref. 3) was used to estimate the change in bearing preload that would result because of net length error at the inner spacer. Figure 13 shows those results. The upper plot is for net errors resulting in a shorter spacer, and the lower plot is for those resulting in a longer inner spacer (100 percent of error absorbed by the bearings).

Inspection of Figure 13 shows that the preload can be lost if the inner spacer length error exceeds 0.0066 mm (0.00026 in.), which is the amount of ground preload gap space. Conversely, if the spacer is that amount shorter, the preload becomes 2111 N (475 lbf), an increase of 2.9 times. If it were desired to hold the preload error to 50 percent, the spacer tolerance would have to be controlled to ± 0.0026 mm (± 0.000102 in.). More realistic control of preload would be at ± 10 percent of target value. For that case, tolerance on spacer length would have to be maintained at ± 0.0006 mm (± 0.000024 in.). A more rigorous analysis of this interaction would require a finite element model analysis.

Induced Thrust Due to Shaft Interference Fit

Interference fitting of the bearings onto the shaft will cause a reduction in internal clearance within the bearing. This clearance reduction will cause the preload to increase beyond the original ground value of 734 N (165 lbf). Figure 14 shows

the preload thrust induced into the set as a result of the shaft interference fit.

Induced thrust results shown in Figure 14 assume that the bearing races are rigid and cannot expand or stretch under the action of the ball loads. Interference fitting will force all of the reduction in internal clearance into compression of the balls, thus giving a higher level of induced thrust than if the bearing outer race is allowed to stretch from the application of the ball load. The lower curve shows the induced preload thrust for the case where ring stretch or expansion occurs. Since the bearings are slim line bearings, the outer race (in our case) has considerable flexibility and allows a threefold reduction in induced thrust.

Figure 14 also shows that the induced preload can vary from 4486 to 17 466 N (1008 to 3927 lbf) over the range of shaft interference fit if outer-race expansion under ball load is excluded from the calculations. That is, if the outer race is infinitely rigid.

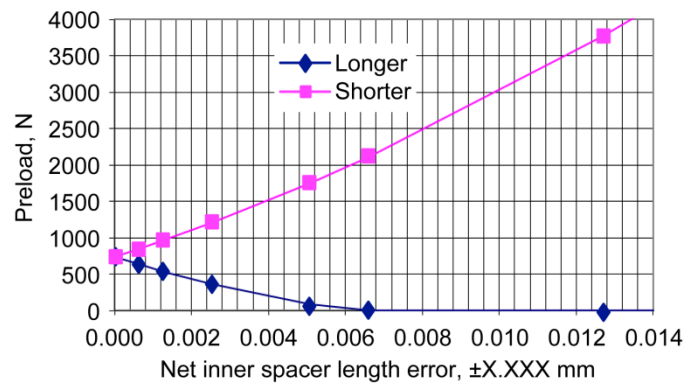

Figure 13.—Effect of spacer length error on spin motor encoder (SME) bearing preload.

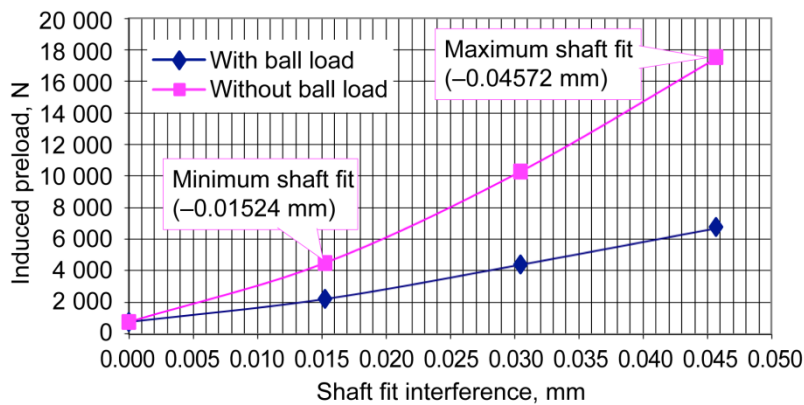

Figure 14.—Induced preload (thrust) due to steel shaft press fit for spin motor encoder (SME) back-to-back (DB) bearings.

If outer-race stretch or expansion from the ball loading is considered, the induced thrust would be lower at 2195 to 6682 N (493 to 1502 lbf) over the shaft interference fit range. These levels are 2 to 3 times lower than if the stretch expansion is not considered. However, the values in Figure 14 still show a significant increase in preload thrust from the original value of 734 N (165 lbf). The preload would increase from 3 times this value at the minimum interference fit to 9 times at the maximum shaft interference fit.

The corresponding increase in maximum Hertz contact stress due to the induced thrust from interference fitting is shown in Figure 15. The results presented in Figure 15 show that the stress ranges from 936 to 1481 MPa (135 800 to 214 800 psi) over the range of interference fit if the outer race is assumed to be rigid. The stress reduces to 735 to 1071 MPa (106 600 to 155 300 psi) when outer-race stretch due to the ball load is included. The latter stress levels are within the range of normal bearing operation (Ref. 11).

Effects of Bearing Operating Temperature

The effect of bearing operating temperature on induced thrust was evaluated by analyzing the bearing system assuming that both the inner and outer races and balls were operating at the same temperature level. Figure 16 shows the effect of bearing operating temperature on induced preload thrust. The shaft fit was taken as the mean fit of -0.0305 mm (-0.00120 in.) for this analysis. Figure 16 also shows that the induced thrust does not change with bearing temperature over the range of 21 to 45 °C (70 to 113 °F). This is because the thermal expansion coefficients of the bearing and shaft steels are comparable. The steel shaft does not exhibit the differential thermal expansion that was detrimental to the original aluminum shaft system.

Effects of Bearing Temperature Gradient

The influence of bearing inner- to outer-race temperature gradient on bearing operation was reviewed. The bearing temperature gradient is negative when the inner race operates at a higher temperature than the outer race. The gradient is positive when the inner race is cooler than the outer race. Negative gradients will cause a reduction in internal clearance, whereas positive gradients will increase the internal clearance. Also, negative gradients will cause the induced thrust to increase, whereas positive gradients will cause a reduction in preload thrust.

Figure 17 shows the effect of positive and negative bearing radial temperature gradients on the induced preload thrust for the SME DB arrangement. As stated, the negative temperature gradient resulting from the inner race being hotter than the outer race increases the induced thrust in this DB set as shown in the left-hand portion of the figure. Results were developed for the maximum and minimum shaft interference fits.

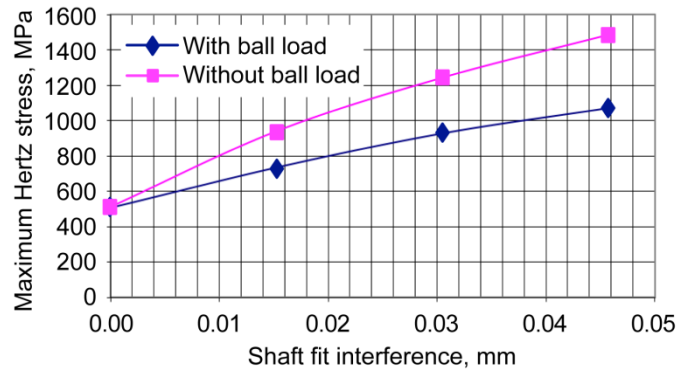

Figure 15.—Maximum Hertz stress due to steel shaft press fit for spin motor encoder (SME) back-to-back (DB) bearings.

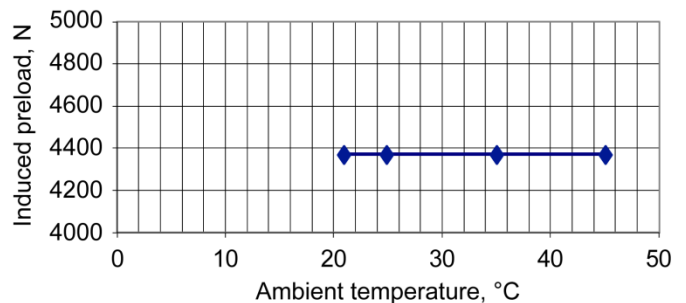

Figure 16.—Bearing operating temperature versus induced thrust for spin motor encoder (SME) back-to-back (DB) bearings with mean steel shaft fit of -0.0305 mm.

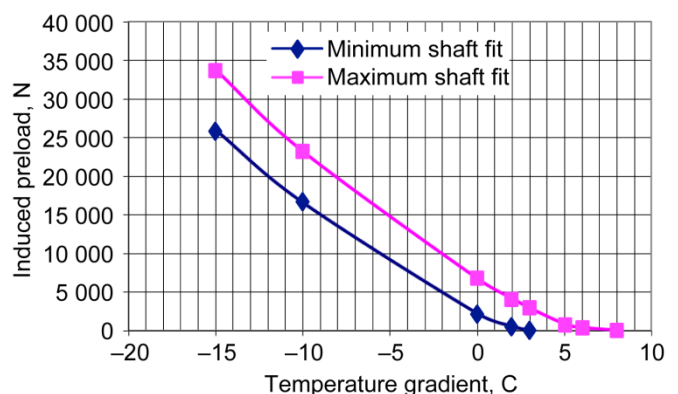

Figure 17.—Bearing-induced preload versus temperature gradient for spin motor encoder (SME) with back-to-back (DB) bearings on a steel shaft where inner-race temperature is higher than outer-race temperature.

JAXA stated that gradients would be in the range of 1 °C (2 °F) based on their thermal analysis models. It is our opinion that gradients of 5 to 10 °C (9 to 18 °F) are more realistic. Also, gradients can be positive because of the outer race being hotter than the inner race. In that case, the DB set could lose preload. Figure 17 shows that if the system develops a positive gradient of about 3 °C (5 °F) with a minimum shaft interference fit, bearing preload can be lost. Preload loss can also occur at about 8 °C (14 °F) for the bearings mounted with the maximum shaft interference fit.

If the system develops a negative gradient in the range of 5 to 10 °C (9 to 18 °F), the induced thrust would vary from about 15 000 to 23 150 N (3370 to 5200 lbf) for the maximum interference fit condition. The corresponding maximum Hertz stress would be 1628 MPa (236 060 psi) for the 10 °C (18 °F) case. More rigorous determination of the operating temperature gradient would be required in order to better determine the level of thrust buildup.

The positive gradient also presents a detrimental situation if those values exceed the estimated 3 to 8 °C (5 to 14 °F) needed for unloading the set. This suggests that a higher starting preload is needed. However, a higher starting preload may further aggravate the negative gradient issue, resulting in even higher induced thrust load than predicted. More rigorous measurement and/or thermal modeling are required to quantify and clarify these issues.

Bearing Assembly L_1 Fatigue Life

The L_1 fatigue life for the DB bearing set was estimated at different temperature gradients for the set operating at 42 rpm with the maximum and minimum shaft fits. These results are shown in Figure 18. A 10-year operating time at 50 percent utilization is required for the centrifuge. This equates to 5 years or 43 800 h of continuous operation.

Figure 18 shows that a maximum allowed negative gradient (hot inner race) of about 4.5 °C (8.1 °F) could not be exceeded if the unit were assembled with the maximum shaft interference fit. The allowable gradient would increase to about 8 °C (14 °F) if the assembly was built to the minimum shaft interference fit. The sensitivity of L_1 life to operating temperature gradient is due to the buildup of the induced thrust well beyond the preload. Once again it becomes necessary to better define the operating thermal gradients within these bearings to determine a life estimate.

Bearing Seizure Tests

Based on the criteria set forth in NASA Handbook-5010, Appendix K (Ref. 12), an analysis was conducted by Ohtomi et al. (Ref. 13) to understand the performance of the CR in space. The authors of this study were from Toshiba, JAXA,

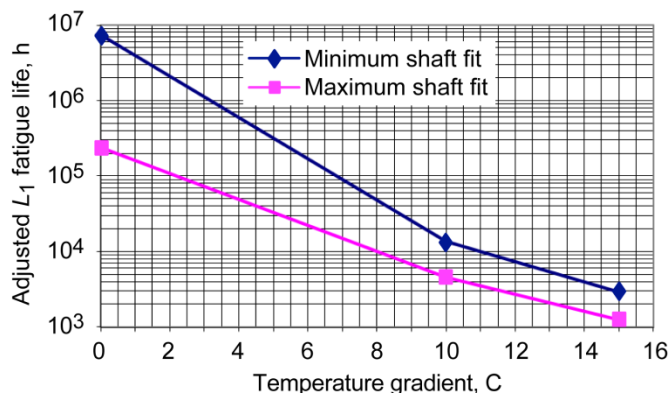

Figure 18.—Adjusted bearing L_1 fatigue life versus temperature gradient for spin motor encoder (SME) with back-to-back (DB) bearings on a steel shaft where inner-race temperature is higher than outer-race temperature.

and NASA Ames Research Center. According to the analysis presented in Reference 13 there is risk that damage might occur if the CR were to suddenly seize within 1 s when rotating at its maximum speed of 41 rpm.

The slip ring assembly (SRA) and the fluid slip joint (FSJ) bearings were not analyzed by the NASA team because JAXA did not provide the required information for an engineering analysis. However, in order to evaluate the likelihood of a sudden bearing lockup that may threaten the integrity of the ISS structure, JAXA performed seizure testing on bearing types representing the FSJ bearing, the SRA bearing, and the RSA deep-groove ball bearing. The two main lockup threats are from external or internally generated debris or from a lubricant-failure-induced thermal runaway condition that would cause a thermal lockup of the bearing. The NASA bearing team strongly recommended like and similar testing of the SME bearings because they have a higher seizure risk. The objectives of these tests were to (1) evaluate the risk that the bearings might seize under worst-case debris and thermal gradient conditions and (2) monitor the bearing torque signature during seizure to bound the peak dynamic torque.

The FSJ test bearing was a commercial version of the FSJ bearing with speed torque and temperature monitoring sensors. The bearing used was a standard 105 size, having typically 13 balls 0.64 cm (0.25 in.) in diameter. This 25- by 47-mm bearing was intentionally run dry to evaluate seizure potential and the effectiveness of various monitoring approaches. The preload was 200 N (45 lbf). Under this dry condition it was not possible to obtain a failure in 1 h. Therefore, the decision was made to impose an additional radial load. The radial load was increased to 4000 N (900 lbf) on the spindle, representing a load of about 2000 N (450 lbf) on the test bearing, assuming equal load sharing. However, since the load was not applied symmetrically and the clearance between the two bearings at their outer race is slightly

different, the load sharing may not be 50 percent. In any case, the bearing was highly loaded.

Under the preloading and radial load used (assuming equal load split), the bearing maximum Hertz stress is approximately 3 GPa (400 ksi), which is a very high contact stress. Despite this extremely high stress and no lubricant condition, seven different test bearings survived more than 80 min before experiencing a hard failure. Some bearings survived as long as 110 min. This makes a strong statement of the robustness of the bearing even if the test bearing material and ball retainer are different than those in flight. The test bearings that had stamped ribbon steel cages were made from AISI 52100 steel. The flight bearing is made of AISI 440C stainless steel, and the bearing retainer is a more robust, one-piece design presumably made of phenolic material.

JAXA/NTSpace reran these tests with the roughly 2× larger SRA bearing using flight materials and design that would envelope the FSJ results. The torque time history presented showed maximum torque level of more than 120 N·m (89 lbf·ft) (the saturation limit of the torque meter) but less than 300 N·m (221 lbf·ft), which is the damage limit of the torque meter. These levels represent a factor of safety of more than 4 relative to damage to the FSJ mount and a factor of 75 relative to the ISS structure. It can be concluded with reasonable engineering certainty that seizure of the FSJ bearing represents no hazard to the ISS structure.

The RSA deep-groove ball bearing seizure testing showed the bearing did not lock up after introduction of debris occupying up to 10 percent of the volume of the bearing cavity. The torque was also manageable for an intentionally dry bearing with temperature gradients in excess of 40 °C (72 °F). The torque buildup was reasonably gradual over the course of 2 h. There were, however, momentary torque spikes, which may suggest that the bearing momentarily locked up and began to rotate on either its shaft and/or within the outer-ring housing. Typically, when a thermally locked bearing cools down, it then begins to operate in a normal fashion. The test bearing housing outer ring should be examined for evidence of bearing slipping. Also, the bandwidth of the torque data acquisition system should be validated to ensure that the true magnitudes of transient torque spikes were captured. Of all of the CR bearings, the RSA deep-groove ball bearing would be expected to have the least sensitivity to thermal and debris lockup since its inner and outer rings are loosely mounted (free to turn) and the outer race is constrained only by a soft spring preload. Therefore, it easily relieves internal preload buildup. Although not a catastrophic failure, this would still require shutdown and repair.

FSJ bearing seizure tests exposed each of the seven flight-like FSJ bearings to over 80 min of run time under dry conditions and high radial loads (with maximum Hertz stress approximately 3 GPa, or 425 ksi). Maximum torque levels were less than 25 percent of the level to cause mounting

damage structure and 75 times smaller than that necessary to damage the ISS main structure.

In contrast, the SME duplex angular-contact ball bearings have a hard preload and a large number of small bearing balls, making them less tolerant to debris or internal clearance reductions. Of the CR bearing designs evaluated, the NASA bearing team was of the opinion that the SME bearings have a higher risk of seizure than any of the other bearings in the CR system and should be tested for seizure. Planned testing on the SME bearings was not performed before the program was discontinued.

Summary of Results

A team of NASA bearing and lubrication experts was assembled to assess the risk for bearings used in the International Space Station centrifuge rotor (CR) to seize or otherwise fail to survive for the required 10-year operational life. The CR was designed by the Japan Aerospace Exploration Agency (JAXA) and their subcontractor NEC Toshiba Space Systems Ltd. (NTSpace). The NASA bearing team performed a design audit for the most critical bearing systems and reviewed the lubricant selected. The following were the recommendations, conclusions, and opinions of the NASA team:

1. There is uncertainty regarding the ability of the Braycote 601 grease base on 815Z oil to reliably provide the 10-year continuous life required without relubrication of the system. There was no Rotor Shaft Assembly (RSA) or spin motor encoder (SME) bearing life test data available for evaluation. Grease endurance tests are required to confirm grease life mission requirements without the need to relubricate the bearings.

2. The fatigue life of the RSA spring-preloaded, front-to-front (DF) mount bearing set at a 99-percent probability of survival (L_1 life) was estimated at 700 million hours and the single ball bearing (Row 3) at 58 million hours. These lives satisfy the mission requirements for fatigue. However, this does not mean that the grease life will meet mission requirements.

3. It was recommended that the RSA DF bearing design be modified to increase margins for the bearing. It was further recommended that the RSA DF spring preloaded bearing arrangement utilize a C4 or greater internal diametral clearance in the single radial ball bearing (Row 3) of this system.

4. The SME back-to-back bearing arrangement mounted on a steel shaft will be less sensitive to bearing operating temperature than the earlier reported DF bearings on an aluminum shaft. However, the system is still very sensitive to the shaft interference fit and temperature gradients. Negative temperature gradients (hotter inner race) greater than 4.5 to 8 °C (8.1 to 14 °F), depending upon the preload, will lower the L_1 life below the required life.

5. A positive temperature gradient (cooler inner race) will reduce the preload in the SME bearings. A positive gradient beyond 3 °C (5 °F) may cause complete loss of preload if the bearings are assembled at the minimum shaft interference fit. If the unit is assembled at the maximum shaft interference fit, a positive gradient of 8 °C (14 °F) can unload the set. These results showed a need to better define and quantify the operating temperature gradients that can develop in the bearing system.

6. There is a probability that the SME bearings would have operated in a boundary-lubricated regime, resulting in unacceptable bearing wear. There is no analysis that can predict the bearing wear rate with any reasonable engineering certainty.

7. The SME bearings are particularly vulnerable to debris and thermal lockup loads and should be fully tested in a seizure test to verify that it would be unlikely to cause the rotating CR to seize in under 1 s.

8. The RSA deep-groove ball bearing seizure testing showed the bearing did not lock up after introduction of debris occupying up to 10 percent of the volume of the bearing cavity. The torque was also manageable for an intentionally dry bearing with temperature gradients in excess of 40 °C (72 °F). The torque buildup was reasonably gradual over the course of 2 h. Fluid slip joint (FSJ) bearings were also successfully tested for resistance to seizure.

9. Momentary torque spikes observed during seizure testing of the RSA deep-groove ball bearing suggest that the bearing momentarily locked up and began to rotate on either its shaft and/or within the outer-ring housing. Typically, when the bearing cools down it then begins to operate in a normal fashion. The test bearing housing and shaft bearing mounting surfaces should be examined for evidence of bearing slipping. Also, the bandwidth of the torque data acquisition system should be validated to ensure that the true magnitudes of transient torque spikes were captured.

10. The bearing arrangements of the slip ring assembly (SRA) and the FSJ could not be reviewed and evaluated because JAXA did not supply the appropriate bearing information.

Epilogue

The Centrifuge Accommodations Module (CAM) was originally scheduled for both development and construction in the United States. The CAM had two objectives: (1) Determine the role gravity has in the development of organisms from the cellular level up to that of an entire individual organism and (2) Determine the effect of gravity levels and exposure times on the health, safety, and productivity of humans during long-term space travel such as to Mars. In 1998 an agreement between the United States and Japan provided that Japan would design and build the

centrifuge rotor (CR) and the CAM at its own expense. This was to offset the cost to Japan of launching the Japanese Experiment Model also known by the nickname Kibo (meaning “hope” in Japanese). The CAM was scheduled to be launched to the International Space Station (ISS) in 2006 aboard a U.S. space shuttle (Ref. 1).

In February 2003, when NASA Ames Research Center requested NASA Glenn Research Center to help assess the potential risk if one of the bearings failed in the ISS CR, the CAM was behind schedule and would not have been completed in time to make a 2006 launch date to the ISS. However, subsequent to the Space Shuttle *Columbia* tragedy, the module was tentatively rescheduled for launch in 2008. In January 2005, at the Heads of Agency meeting of the International Space Station International Partners it was decided to cancel plans to launch the CR and the CAM because of the few remaining scheduled flights (from 28 to 16) of the space shuttles before their scheduled retirement in 2010 (Ref. 14). As a result, the CAM and CR program was canceled September 2005.

On March 14, 2005, an Executive Summary of the work was written and submitted by the NASA Glenn bearing team to Robert D. Barber, SSBRP Host Systems Manager at the NASA Ames Research Center. On August 3, 2005, a final report was submitted by the team that expanded on the Executive Summary and contained the material presented in this paper. The findings, conclusions, and recommendations presented represented the consensus of the members of the bearing team. Since the program was cancelled 1 month later, it became obvious that no action would be taken on the recommendations of the NASA Glenn bearing team.

At the time of cancellation, the Japan Aerospace Exploration Agency (JAXA) and their subcontractor NEC Toshiba Space Systems Ltd. (NTSpace) had partially completed the CAM and had manufactured components of the CR. However, the CR was not assembled and tested. The CAM without the CR is displayed in an outdoor exhibit at the Tsukuba Space Center, Japan (Ref. 2).

There are advocates of space-based centrifuges within the gravitational biology and artificial gravity communities (Refs. 15 and 16). The authors of Reference 15 state: “The need for space-based centrifuges for both research applications and astronaut countermeasures has been articulated for decades. ... The cancellation of the Centrifuge Accommodation Model (CAM) planned for ISS left life sciences researchers with no rotational or glove box facilities for flight investigations, and reopened the call for such a core capability.” Among the recommendations the authors of Reference 15 made were (1) “...salvage elements of the Japanese CAM (centrifuge) rotor (CR) and supporting hardware” or (2) “Leveraging existing CAM experience and designs to prepare a double rack-scale small animal centrifuge for use on the ISS or a free-flyer platform.”

If the CR and supporting hardware were to be used for the ISS, or if a new centrifuge is to be procured, the issue regarding grease life meeting mission requirements would need to be addressed. Since the issuance of the Final Report, Bearing Assessment for Centrifuge Rotor, International Space Station¹ to the SSBRP Host Systems Manager on August 3, 2005, no definitive work has been undertaken by NASA to determine if grease life will meet mission requirements with any reasonable engineering and statistical certainty (refer to entry 1 under the Summary of

Results above). However, JAXA (Refs. 17 and 18) has conducted two definitive studies to determine the effect on bearing fatigue life of two candidate greases for CR application (refer to entry 2 under the Summary of Results above and to the Appendix). The ability to perform long-term human space missions and to return safely to Earth will depend on the continuously reliable operation of rotating machinery in the space environment and the ability to assure a continuously functioning lubrication system to the operating components.

¹The current report summarizes this past internal document.

Appendix.—Braycote 601 Grease

The NASA study for the bearing assessment for the centrifuge rotor (CR) for the International Space Station (ISS) was undertaken December 11, 2003. This was approximately 11 months after the disaster that destroyed the Space Shuttle *Columbia* occurred on its 28th flight, February 1, 2003. The United States space shuttle fleet was originally intended to have a life of 100 flights for each vehicle, over a 10-year period, with minimum scheduled maintenance or inspection. The first space shuttle flight was that of the Space Shuttle *Columbia*, launched April 12, 1981. The disaster that destroyed the *Columbia* occurred nearly 22 years after first being launched.

Actuators used on the United States space shuttle fleet are lubricated with unspecified amounts of Braycote 601 grease (Castrol Limited) consisting of perfluoropolyalkyl ether (PFPAE) base oil (815Z oil) thickened with polytetrafluoroethylene (PTFE). Each shuttle has four body flap actuators (BFAs), two on each wing, on a common segmented shaft and four rudder speed brake (RSB) actuators. The actuators were designed to operate for 10 years and 100 flights without periodic relubrication. As a result of the *Columbia* accident, concern was raised in July 2003 over possible grease degradation and wear of BFAs.

The actuators presented a unique opportunity to assess the condition of the NLGI Grade 2 PFPAE grease that had been in use for at least 20 years lubricating the bearings and gears inside these actuators. One primary area of concern was the extent of base oil separation from the grease thickener leading to less than adequate lubrication. The other area of concern was base oil degradation and its effect on the condition of the grease and its ability to provide effective lubrication.

Visible inspection of two partially disassembled RSB actuators in continuous use for 19 years raised concerns over possible grease degradation due to discoloration of the grease on several places on the surfaces of the gears. Inspection revealed fretting, micropitting, wear, and corrosion of the bearings and gears. A small amount of oil dripped from the disassembled actuators. Whereas new grease is beige in appearance, the discolored grease consisted of both grey and reddish colors. Grease samples taken from the actuators together with representative off-the-shelf new, unused grease samples were analyzed by (1) gravimetry for oil content, (2) by inductively coupled plasma analysis (ICP) for metals content, (3) Fourier transform infrared (FTIR) spectroscopy for base oil decomposition, and (4) by size exclusion chromatography (SEC) for determination of the molecular weight distributions of the base oil.

The Braycote 601 grease was physically and chemically stable after 19 years of continuous use in the sealed RSB actuators and was fit for its intended purpose. There were no

significant chemical differences between the used grease samples and new and unused samples. Base oil separation was not significant within the sealed actuators and no iron fluoride was detected. The grey color of grease samples was due to metallic iron. The red color was due to oxidation of the metallic wear particles from the gears and the bearings comprising the actuators.

A search of the literature reveals a large amount of qualitative wear data that has been generated on an assortment of laboratory testers over a period of decades. Equations and analysis exist together with friction and wear data to allow for calculating lubricant film thickness, lubrication operating regime, and the qualitative severity of the wear (Refs. 19 to 21). However, there is no definitive analysis that allows an engineer to predict, with any reasonable degree of engineering certainty, the quantity of wear or the applicable usable life of a specific lubricant (grease) that can occur in a specific application. Quantitative results need to be obtained experimentally for specific applications (Ref. 22).

Ohno et al. (Ref. 17)) tested two greases used for space applications and their respective base oils. All tests were done under ambient laboratory temperature and air atmosphere. One of the greases was the same or similar PFPAE grease to that used for the space shuttle actuators. Tests were performed in order to characterize the rheological base oil behavior of each grease as a function of pressure and temperature. Longer ball bearing fatigue life was obtained with the PFPAE grease than with the PFPAE-base oil (Ref. 17).

Analysis showed that the viscosity of the PFPAE-base oil, containing perfluoromethyl- and perfluoroethyl-ether groups ($-(CF_2)O-$) and ($-(CF_2)_2O-$), was lowered by the high shear rates in the elastohydrodynamic (EHD) Hertzian contact. Ohno et al. (Ref. 17) concluded that the PFPAE-base oil decomposes, generating acid fluoride, which then hydrolyzes to hydrogen fluoride by reacting with moisture. As a result, the formation of the hydrogen fluoride shortens bearing life by forming metal fluorides when run with only the base oil. However, for the PFPAE grease viscosity loss of the base oil did not occur (i.e., no base oil decomposition), resulting in longer bearing life (Ref. 17). The analysis of the Braycote 601 grease used in the space shuttle actuators did not show any decomposition of the PFPAE base oil and/or the generation of acid fluoride or hydrogen fluoride as might be expected.

In a continuation of the research reported in Reference 17, Ohno et al. (Ref. 18), performed bearing fatigue tests of the PFPAE base (815Z) oil and multiply alkylated cyclopentane (MAC 2001A) base oil in air and vacuum environments. The test oils were analyzed to determine whether changes occurred as a result of operating in air and in a vacuum. In vacuum, the

PFPAE base (815Z) oil had a longer fatigue life than the MAC 2001A oil. However, in an air environment, the MAC 2001A had a longer fatigue life than the PFPAE base (815Z) oil.

The bearing fatigue life of the PFPAE (815Z) base oil when tested in vacuum had a longer fatigue life than when tested in air. In an air environment, hydrogen fluoride was generated in the bearing tests with the PFPAE oil. However, after testing in a vacuum environment, hydrogen fluoride was not detected. It is possible that hydrogen fluoride was generated in the vacuum tests but dissipated before it could be detected. This may explain that in the analysis of the Braycote 601 grease taken from the Space Shuttle actuators, there was no acid fluoride and/or hydrogen fluoride present since the actuators from the Space Shuttle functioned in a vacuum environment.

Rolling-element fatigue is not a credible failure mode for the centrifuge bearings because the predicted L_1 life (the life at a 99-percent probability of survival) is in excess of 50 million hours. The concern is lubricant life leading to eventual bearing failure. In vacuum, MAC lubricants clearly provide longer lives than PFPAE-based fluids. For example the angular contact ball bearings lubricant life tests conducted in vacuum (Ref. 23) showed that the MAC 2001 oil enjoyed an 18 times life advantage over the PFPAE 815Z oil. Similarly ball-on-plate spiral orbit tribometer (SOT) vacuum life tests (Ref. 24) showed even greater life advantages for MAC 2001A oil over the PFPAE Z25 oil, which is similar to 815Z oil.

Space lubricant life test data in air is difficult to find. This is because space lubricants spend most of their operational lives in a space vacuum environment. However SOT lubricant tests were conducted in one atmosphere, N_2 , (Ref. 25) with various levels of moisture to simulate that in found in air. It was reported that PFPAE oil life in the presence of a trace amount of water moisture is substantially better than when tested in a vacuum. Only 16 ppm water vapor in 1 atm nitrogen, corresponding to a relative humidity of <0.07 percent, is sufficient to extend the vacuum lifetime of the PFPAE (Krytox 143 AC (DuPont)) oil by an order of magnitude. Similarly lubricant life of MAC 2001A oil was extended by a factor of 6 in the presence of 75 ppm of water. Because of water moisture in the laboratory, lubricant life would always be greater when obtained there than when obtained in vacuum. This suggests that lubricant life testing in air is not an acceptable substitute for vacuum life testing. The study also showed that MAC 2001A oil life was at least an order of magnitude greater than the PFPAE oil life at comparable moisture levels.

The fatigue life tests of the MAC 2001A base oil in a vacuum resulted in shorter life than when tested in an air environment. Ohno et al. (Ref. 18) attributed this result to the lower EHD film thickness with the MAC 2001A oil in a vacuum because of higher operating temperature and decomposition of the oil in vacuum (Ref. 18). This would suggest that, since the environment in which the space centrifuge was to operate was air, grease blended with the MAC 2001A base oil would produce longer bearing lives than the Braycote 601 grease.

In the study by Krantz et al. (Ref. 26), spur gear pairs made from AISI 9310 steel, the same material used for the actuator gears without surface coatings, were lubricated with the NLGI Grade 2 PFPAE grease. The gear pairs were loaded to a maximum Hertz stress of 1.1 GPa (160 ksi) and operated under a dithering motion at ambient (room) temperature and atmosphere. The gears were run from 20 000 to 80 000 total dithering cycles. The wear rate for these spur gears “was on the order of 600 times greater than referenced data for oil lubricated gears” using six different polyol esters and one polyalkylene-glycol-based oil (Ref. 26). In a related study Krantz, et al. (Ref. 27), lubricated spur gear pairs with PFPAE grease and ran them under different atmospheres. The tests conducted under ambient air or dry air produced reddish-colored debris in the PFPAE grease, whereas tests conducted in dry nitrogen (N_2) produced grey-colored debris in the grease. Neither the reddish- nor the grey-colored debris were chemically identified. However, we now know from Morales, Street, and Zaretsky (Ref. 28) that the grey-colored debris was metallic iron and the red color was due to oxidation.

Bearing grease life for most applications is not deterministic but probabilistic. However, without an existing data base and/or field experience, it cannot be determined with any reasonable engineering and statistical certainty how long a grease will function in a bearing before oil depletion in the grease results in a “dead grease.” Nonaerospace industrial practice would suggest that bearing grease regardless of the environment and usage be periodically changed at no more than a 5-year interval or less. The design of the CR for the ISS, which was to run for 10 years continuously, could not accommodate relubrication of the bearings in the system. The remaining issue for the bearings in the CR for the ISS was how much wear can be tolerated before they are no longer fit for their intended application?

References

1. Space Station User's Guide: ISS Elements: Centrifuge Accommodation Module (CAM). SpaceRef Interactive, 2013. <http://www.spaceref.com/iss/elements/cam.html> Accessed July 30, 2013.
2. Wikipedia, the free encyclopedia: Centrifuge Accommodations Module. http://en.wikipedia.org/wiki/Centrifuge_Accommodations_Module Accessed Nov. 5, 2012.
3. Poplawski, Joseph V., et al.: Advanced Analysis Package for High Speed Multi-Bearing Shaft Systems (COBRA-AHS); Final Report. NASA Contract NAS3-00018, 2002. Available from the NASA Small Business Innovation Research and Small Business Technology Transfer Program Office.
4. Castrol: Castrol Brayco 815Z Product Literature. Castrol Industries North America, Inc., Naperville, IL, 2005.
5. Carré, David J.: The Performance of Perfluoropolyalkylether Oils Under Boundary Lubrication Conditions. Trib. Trans., vol. 31, no. 4, 1988, pp. 437-441.
6. Gschwender, Lois J.; and Snyder, Carl E., Jr.: U.S. Air Force Perfluoropolyalkylether Experiences. Trib. Trans., vol. 52, no. 2, 2009, pp. 165-170.
7. Jansen, Mark J., et al.: Relative Lifetimes of Several Space Liquid Lubricants Using a Vacuum Spiral Orbit Tribometer (SOT). NASA/TM-2001-210966, 2001. <http://ntrs.nasa.gov/>
8. Martinez, A.N.: Lockheed Martin Corporation, NASA Johnson Space Center, Braycote-601 Problems in TVIS Gyro Bearings. Internal presentation for NASA Space Station Management, 2004.
9. Bazinet, Dean G., et al.: Life of Scanner Bearings With Four Space Liquid Lubricants. J. Synth. Lubr., vol. 23, no. 2, 2006, pp. 81-90.
10. Buttery, Michael: An Evaluation of Liquid, Solid, and Grease Lubricants for Space Mechanisms Using a Spiral Orbit Tribometer. NASA/CP-2010-216272, 2010, pp. 59-71. <http://ntrs.nasa.gov/>
11. Loewenthal, Stuart: Space Mechanism Lubrication. Handbook of Lubrication and Tribology. Volume II: Theory and Design, Second Edition, Robert W. Bruce, ed., CRC Taylor and Francis, Boca Raton, FL, 2012, p. 63-1.
12. NASA-HDBK-5010, Fracture Control Implementation Handbook for Payloads, Experiments and Similar Hardware, Appendix K, June 5, 2005. <https://standards.nasa.gov/documents/detail/3315149>
13. Ohtomi, K. et al.: Centrifuge Rotor Integrated Analysis, Modeling Simulation and Calibration of Space-based Systems, Pejmun Motagh, ed., Proc. of SPIE, Vol. 5420, Bellingham, WA, 2004, pp. 1-10.
14. Behrens, Carl E.: The International Space Station and the Space Shuttle. CRS Report for Congress CRS-RL33568, 2009.
15. Young, Laurence R., et al.: Another Go-Around: Revisiting the Case for Space-Based Centrifuges. Gravitational and Space Biology, vol. 25, no. 1, 2011, pp. 66-68.
16. Katahira, Kiyooki, et al.: The Prospect of Rodent Experiments in Space. Space Utilization Research: Proceedings of the Twenty-second Space Utilization Symposium, Tokyo, Japan, 2006, pp. 266-269. Available from the Japan Aerospace Exploration Agency.
17. Ohno, Nobuyoshi, et al.: Bearing Fatigue Life Tests in Advanced Base Oil and Grease for Space Applications. Tribol. Trans., vol. 52, no. 1, 2008, pp. 114-120.
18. Ohno, Nobuyoshi, et al.: Bearing Fatigue Life Tests of Two Advanced Base Oils for Space Applications Under Vacuum and Atmospheric Environments. Tribol. Trans., vol. 54, no. 6, 2011, pp. 859-866.
19. Bhushan, Bharat: Modern Tribology Handbook. Volume One, CRC Press, Boca Raton, FL, 2000.
20. MacGregor, Charles Winters: Handbook of Analytical Design for Wear. Plenum Press, New York, NY, 1964.
21. Booser, E. Richard: CRC Handbook of Lubrication: Theory and Practice of Tribology. Volume II: Theory and Design, CRC Press, Boca Raton, FL, 1983.
22. Oswald, Fred B., et al.: Probabilistic Analysis of Space Shuttle Body Flap Actuator Ball Bearings. Tribol. Trans., vol. 51, no. 2, 2008, pp. 193-203.
23. Loewenthal, Stuart H.; Jones, William R., Jr.; and Predmore, Roamer: Life of Pennzane and 815Z-Lubricated Instrument Bearings Cleaned With Non-CFC Solvents. ESA SP-438, 1999. Available from the European Space Agency.
24. Jansen, Mark J., et al.: Relative Lifetimes of Several Space Liquid Lubricants Using a Vacuum Spiral Orbit Tribometer (SOT). Proceedings of 2nd World Tribology Congress (NASA/TM-2001-210966), International Tribology Council, Vienna, Austria, 2001. <http://ntrs.nasa.gov/>
25. Pepper, Stephen V.: Effect of Test Environment on Lifetime of Two Vacuum Lubricants Determined by Spiral Orbit Tribometry. NASA/CP-2006-214290, 2006. <http://ntrs.nasa.gov/>
26. Krantz, Timothy; Oswald, Fred; and Handschuh, Robert: Wear of Spur Gears Having a Dithering Motion and Lubricated With a Perfluorinated Polyether Grease. ASME Paper No. DETC2007-34089 (NASA/TM-2007-215008), 2007. <http://ntrs.nasa.gov/>
27. Krantz, Timothy L.; and Handschuh, Robert F.: A Study of Spur Gears Lubricated With Grease-Observations From Seven Experiments. NASA/TM-2005-213957 (ARL-TR-3159), 2005. <http://ntrs.nasa.gov/>
28. Morales, Wilfredo; Street, Kenneth W.; and Zaretsky, Erwin V., Jr.: Performance and Analysis of Perfluoropolyalkyl Ether Grease Used on Space Shuttle Actuators—A Case Study. Tribol. Trans., vol. 55, no. 1, 2012, pp. 77-85.

REPORT DOCUMENTATION PAGE			Form Approved OMB No. 0704-0188		
<p>The public reporting burden for this collection of information is estimated to average 1 hour per response, including the time for reviewing instructions, searching existing data sources, gathering and maintaining the data needed, and completing and reviewing the collection of information. Send comments regarding this burden estimate or any other aspect of this collection of information, including suggestions for reducing this burden, to Department of Defense, Washington Headquarters Services, Directorate for Information Operations and Reports (0704-0188), 1215 Jefferson Davis Highway, Suite 1204, Arlington, VA 22202-4302. Respondents should be aware that notwithstanding any other provision of law, no person shall be subject to any penalty for failing to comply with a collection of information if it does not display a currently valid OMB control number.</p> <p>PLEASE DO NOT RETURN YOUR FORM TO THE ABOVE ADDRESS.</p>					
1. REPORT DATE (DD-MM-YYYY) 01-01-2014		2. REPORT TYPE Technical Paper		3. DATES COVERED (From - To)	
4. TITLE AND SUBTITLE Analysis of Space Station Centrifuge Rotor Bearing Systems: A Case Study			5a. CONTRACT NUMBER		
			5b. GRANT NUMBER		
			5c. PROGRAM ELEMENT NUMBER		
6. AUTHOR(S) Poplawski, Joseph, V.; Loewenthal, Stuart, H.; Oswald, Fred, B.; Zaretsky, Erwin, V.; Morales, Wilfredo; Street, Kenneth, W., Jr.			5d. PROJECT NUMBER		
			5e. TASK NUMBER		
			5f. WORK UNIT NUMBER WBS 877868.02.07.03.01.01.01		
7. PERFORMING ORGANIZATION NAME(S) AND ADDRESS(ES) National Aeronautics and Space Administration John H. Glenn Research Center at Lewis Field Cleveland, Ohio 44135-3191			8. PERFORMING ORGANIZATION REPORT NUMBER E-18706		
9. SPONSORING/MONITORING AGENCY NAME(S) AND ADDRESS(ES) National Aeronautics and Space Administration Washington, DC 20546-0001			10. SPONSORING/MONITOR'S ACRONYM(S) NASA		
			11. SPONSORING/MONITORING REPORT NUMBER NASA/TP-2014-217906		
12. DISTRIBUTION/AVAILABILITY STATEMENT Unclassified-Unlimited Subject Category: 37 Available electronically at http://www.sti.nasa.gov This publication is available from the NASA Center for AeroSpace Information, 443-757-5802					
13. SUPPLEMENTARY NOTES					
14. ABSTRACT A team of NASA bearing and lubrication experts was assembled to assess the risk for the rolling-element bearings used in the International Space Station (ISS) centrifuge rotor (CR) to seize or otherwise fail to survive for the required 10-year life. The CR was designed by the Japan Aerospace Exploration Agency and their subcontractor, NEC Toshiba Space Systems, Ltd. (NTSpace). The NASA team performed a design audit for the most critical rolling-element bearing systems and reviewed the lubricant selected. There is uncertainty regarding the ability of the Braycote 601 grease (Castrol Limited) to reliably provide the 10-year continuous life required without relubrication of the system. The fatigue life of the Rotor Shaft Assembly (RSA) spring loaded face-to-face mount at a 99-percent probability of survival (L_1 life) for the ball bearing set was estimated at 700 million hours and the single ball bearing (Row 3) at 58 million hours. These lives satisfy the mission requirements for fatigue. Rolling-element seizure tests on the RSA and fluid slip joint bearings were found unlikely to stop the centrifuge, which can cause damage to the ISS structure. The spin motor encoder duplex angular-contact ball bearings have a hard preload and a large number of small balls have the highest risk of failure. These bearings were not tested for seizure even though they are less tolerant to debris or internal clearance reductions.					
15. SUBJECT TERMS Rolling element bearings; Roller bearings; Ball bearings; Life prediction; Stress					
16. SECURITY CLASSIFICATION OF:			17. LIMITATION OF ABSTRACT	18. NUMBER OF PAGES	19a. NAME OF RESPONSIBLE PERSON
a. REPORT	b. ABSTRACT	c. THIS PAGE			STI Help Desk (email:help@sti.nasa.gov)
U	U	U	UU	28	19b. TELEPHONE NUMBER (include area code) 443-757-5802

