

NASA KSC – Internship Final Report

Structural Analysis Using NX Nastran 9.0

Benjamin M. Rolewicz

Kennedy Space Center (KSC)

Major: Mechanical Engineering

Program: Structural or Fluids Analysis, Summer 2014

Date: 29/07/2014

Structural Analysis Using NX Nastran 9.0

Benjamin M. Rolewicz¹
Cornell University '15, Ithaca, NY, 14850

NX Nastran is a powerful Finite Element Analysis (FEA) software package used to solve linear and non-linear models for structural and thermal systems. The software, which consists of both a solver and user interface, breaks down analysis into four files, each of which are important to the end results of the analysis. The software offers capabilities for a variety of types of analysis, and also contains a respectable modeling program. Over the course of ten weeks, I was trained to effectively implement NX Nastran into structural analysis and refinement for parts of two missions at NASA's Kennedy Space Center, the Restore mission and the Orion mission.

I. Introduction

This written work reflects the work I performed during my internship at Kennedy Space Center during the summer of 2014. My efforts began as being geared towards the goal of becoming effective and comfortable using NX Nastran 9.0 for modeling and analysis in general. These efforts were fed by assistance from my mentor, Mr. Syrus Jeanes of NE-M1, the individuals of M1 as a whole, and NX tutorials through Siemens Learning Advantage. Initial learnings of mine were very basic, including starting the program, understanding the controls, and becoming acquainted with the user interface. I moved on to learn about modeling a part or assembly, then learned about the process of performing a successful and effective analysis, including the management of the four files involved in an analysis procedure. As I progressed, I began to explore the capabilities of NX Nastran 9.0, such as thermal system analysis, contact and glued surfaces, and result filtering with envelopes.

Upon achieving the goal of becoming effective in using the software, I performed structural analysis on parts for two of NASA's current missions. The first part, we (Syrus Jeanes and myself) termed the "Composite Flex Hose Box". It is a housing for a multi layered flex hose of a refueling subsystem led by Mr. Jeanes, approximately 36" by 24" by 1.5" and made of carbon fiber laminate. The second part was an aluminum mount for the Orion mission subjected to an acceleration loading.

II. Learning How to Use NX Nastran

NX Nastran is a powerful tool for the engineer, to be used in parallel with first estimate hand calculations and engineering reasoning. In most cases, all three are skills required to produce an accurate analysis. To improve my skills using NX Nastran, I used a combination of experimentation, tutorials from Learning Advantage, and help from the members of the M1 branch. The process began with the understanding of the user interface.

A. User Interface

Once a part or simulation is opened in NX, a variety of options and tools appear along the top and left edges of the screen. Though memorizing these functions would be tedious to remember and difficult to understand, the best way to master the tools of the user interface is to use as many of them as possible and as much as possible. However, it can help the user to first understand what each toolbar contains, to make the learning experience smoother.

On the left edge of the screen is the resource bar. An important reason for the resource bar's existence is the organization of the current project. It contains tabs called "navigators" for each level of a project being worked on, such as the part navigator, assembly navigator, and simulation navigator. Within a tab is a more detailed organization of that level. For example, if the part was modeled in NX, the part navigator gives the user a chronological list of geometry features, known as the model tree, created when building the part. Seeing this, the user can understand how a change may impact other geometries in the part; all geometries created after the geometry being altered are subject to error (However, proper modeling techniques should account for this). The simulation navigator contains all conditions of the simulation, as well as all solutions and results (more details to come in

¹ Summer 2014 Intern, NE-M1, KSC

Section II.C.). Whichever level of a project the user is working in, the navigator is necessary for any progress to be made. The resource bar contains other useful tabs as well, most notably the roles tab and history tab. The roles tab decides the degree of complexity of tool icons seen by the user throughout the screen. It is important to note that are functions are still available for use, so the role tab is only an attempt to make the user’s most likely needed tools more readily available. The history tab keeps track of all files on which the user has performed work, in chronological order, for the last 3 weeks and beyond.

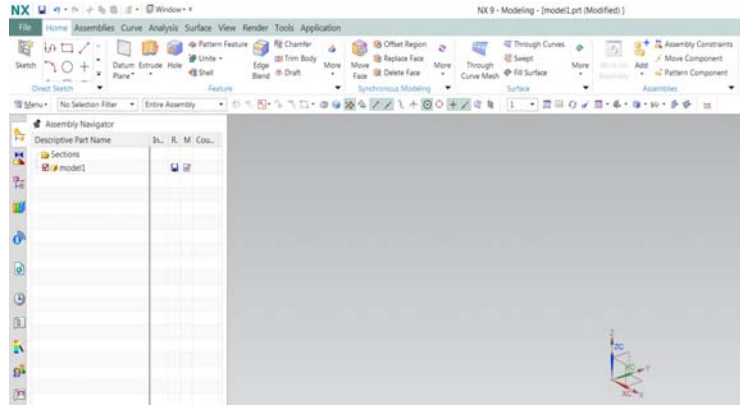

Figure 1. User Interface at home of NX.

Along the very top edge of the screen is the quick access toolbar. The quick access toolbar contains common file options such as save, undo, recently opened parts, etc.

Below the quick access toolbar is the ribbon bar. The ribbon bar holds the core of all actions the user will perform. It is organized into tabs based on the type of action the user will perform, which include but are not limited to: “Assemblies”, “Curve”, “Analysis”, “Surface”, “View”, “Render”, and “Application”. To give an idea of how wide a range of activities are performed from within the ribbon bar, a user can design a part, change its appearance, create an assembly, and start a simulation. The ribbon includes all details of each of the aforementioned activities. It requires a book or set of tutorials to cover everything the user can do from the ribbon bar. This material is best learned through using the software extensively.

Below the ribbon bar and above the graphics window is the top border bar. The top border bar’s most prevalent reason for existence is convenience for the user. This bar contains selection filters, which can be very useful in the case that the user wishes to select many of the same or similar type of geometry, or to select a group of related faces, without having to select each one individually. The top border bar also has orientation and view options.

B. What Makes an Analysis

Finite Element Analysis is a method used by software such as Nastran to solve for conditions on complex models. How this solving process is performed is a topic for another work, however, it can be summarized in the following steps.

First, a model must exist. In the case of structural analysis, this is a part or assembly which, in the real world, will be placed under certain conditions, i.e. loads and constraints, that may cause that part to fail in a way such that its goal or the goal of a larger assembly will not be achieved. This is the problem at hand, for which an analysis can help find a balance between risk and use of material and resources; in other words, an engineering solution is sought.

Next, the model is prepared for solving by applying the situation and creating the mesh. The situation includes all loads, constraints, material properties of the part(s) or assembly, and any other special conditions. A mesh is a series of “nodes” that are spaced throughout the model. The nodes are the points at which the solver will solve. Each node is connected to create a model that consists of a series of “elements”, on which results will be displayed. An element may display a specific combination of the results associated with each of its nodes. A mesh can contain elements that are 0D (point), 1D (beam), 2D (shell), or 3D (solid). A 3D mesh will contain more nodes than a 2D mesh used to represent a solid model, and thus, has more nodes to be solved. An interesting skill aspect of the

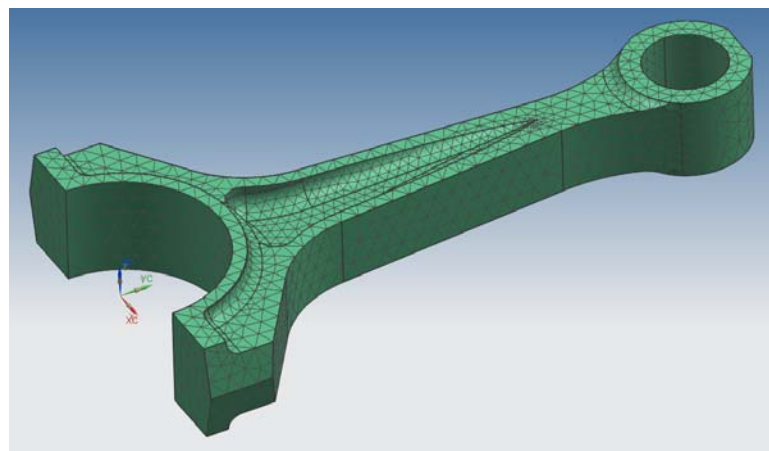

Figure 2. Example of a 3D tetrahedral mesh.

mesh is the spacing of the nodes, in other words, the size of the elements. A “good” mesh is one that keeps elements that are approximately in plane with the material they represent in the model; it keeps the mesh approximately linear. Thus, it is logical that the mesh should be finer around curves and holes than flat faces. NX has a capability known as mesh control, which allows the user to select a geometry feature and adjust the quality of the mesh within that geometry. The user may select an edge, face, or body, and set the number of elements or size of the elements for the selection.

Once the model is prepared, the solver can go to work. Within the software, a system of linear equations are formulated and then solved. In the case of a stress analysis, FEA software uses complex stiffness matrices, which cannot be solved by hand easily, to solve for the displacements of nodes within a model. These displacements are then converted to stresses and strains using simple linear relations that are material-based. Results are written to a file, which the user can view and use to make engineering judgments.

C. The Four Files

The four files that are important in an analysis are all important, and they are known, in order of creation, as the master part, idealized part, fem file, and sim file. As the names may suggest, the master part and idealized part are both .prt files, whereas the fem and sim are each their own unique file type. These descriptions are given in the case of an analysis being done on a single part, rather than an assembly of multiple parts. However, the two processes are very similar.

The master part is simply the modeled part that the user wishes to analyze. This file is no different than the file that was saved after the part was modeled in NX, or imported from a separate CAD program, such as Pro/E, for example. With just a master part file, there is no simulation in progress. However, the simulation is started from the master part.

The idealized part is the only of the four files which is not necessary for a full analysis to occur. The idealized part is nothing more than a copy of the master part to be altered and simplified for the running of the simulation. Simplification is something that should be performed wherever possible, as it will decrease the overall run time of the simulation, saving time without sacrificing significant accuracy in results. Some common examples of simplification inside the idealized part include elimination of unimportant geometries such as small holes, and the modeling of 3-dimensional objects as 2-dimensional surfaces (in FEA terms, modeling a solid as a shell) where appropriate. The tool groups “geometry preparation” and “synchronous modeling” are very helpful for these tasks. Geometry preparation is used for mesh preparation. For example, the user may want to model a thin solid as a 2D surface, in which a tool known as a midsurface is often useful. A midsurface is, as the name suggests, a surface that represents a solid through the middle of its thickness. The thickness is assigned to the midsurface’s properties. Synchronous modeling is used to physically alter the part. From within the synchronous modeling tool, it is quite easy to alter dimensions, adjust faces, and add or remove material. All of these actions may be performed for a given idealized part. An example of a case in which the user may use an idealized part with many alterations using synchronous modeling is an optimization attempt on a master part. The original part will be preserved as the idealized part is altered and used for simulation. If a more preferred part is created, the user may start a new simulation with the once idealized part as the new master part. A new idealized part will be created. This is just one option if a user wishes to keep track of iterations on a part being designed and analyzed. The most important aspect of the idealized part, and the reason for its existence, is that when all files are saved, the idealized part is just the part that will undergo simulation, and the original part (the master) will be preserved.

The .fem file, commonly just called the fem, contains all nodes and elements (the mesh) for the geometry produced in the idealized part (or master part, if no idealized part is used). This includes all 0D, 1D, 2D, and 3D elements, as well as all mesh controls. Fem is actually an acronym for finite element management.

The .sim file is where the simulation

Simulation File View

Name	Status
Session	
ctcs_mount_sim1	Displayed & ...
ctcs_mount_fem1	
ctcs_mount_fem1_i	
ctcs_mount	
fem1	
Advanced Simulation_fundame...	
948CN0910097-501204314	
948CN0970555-001207370	
model1	

Figure 3. The top four files, in order: .sim file, .fem file, idealized part, master part.

is run, and where results are produced. Within the sim file are “containers” of the loads, constraints, and simulation objects (such as contact surfaces) applied to the part being analyzed. Within the sim, there are one or many solutions, each of which can contain their own combination constraints and objects from the containers. Within each solution there may also be multiple subcases; each subcase contains its own combination of loads. Upon solving a solution, a results file will be produced and saved for every subcase.

The four-file system is certainly a useful structure. For a single master part, there may be multiple idealized parts, in the case that the user may want to understand the effects of simplifying a part on the simulation results. For each idealized part, there may be multiple fem files, in the case that the user may like to study the effects of differing meshes on simulation results. And finally, for each fem file, there may be multiple sim files, which can be beneficial for reasons varying by user.

D. Some Specific Capabilities of the Program

There are a few functions of NX which I learned were particularly useful, or had to implement as part of a specific analysis. Specifically, these functions are needed in the handling of interfaces.

It is possible to model any practical kind of interface in NX. Some interfaces that can be seen in the mechanical world that can be modeled in NX successfully are fixed points (perhaps a joint), edges (hinge), and faces, fixed bodies that consist of different materials with different properties (either chemically bonded or assumed to be fixed without disconnecting), bolted parts, and glued surfaces. In the case that the user has a single part that consists of multiple unique materials, the functions “split body” and “divide face” can be very useful. Though still one part file, and still capable of being a single body, these functions allow unique property sets to be applied to each section that was split or divided. The split body function is made for use in solids, most simply by sketching the contour of the split line and extruding through the body. The divide face function is useful in shell configurations, or in solids which are being meshed as midsurfaces. Sometimes, when meshing a single part that has been split, the function “stitch edge” is necessary to tell NX that the part is still a single part.

In the case that two parts or two sections of a single part interact with each other but are not fixed, simulation objects are of good use. Two examples of simulation objects are contact surfaces and glued surfaces. Contact surfaces are based upon friction; two surfaces are being pressed together, or perhaps they contact in small areas due to deflections in parts. The solver requires iterations to produce results for this situation. Glued surfaces are used for circumstances in which only a section two faces are fixed. To get this effect otherwise, the face would have to be divided along the edge of the desired glue contact, and boundary conditions would need to be applied.

Bolted connections are another capability that is particularly useful, because they are found often in real mechanical systems. NX allows the user to input the bolt material and profile from inside the .fem file, and also allows a pre-load to be applied to the bolt due to the torque down of the bolt when tightening. The bolt connection is a 1D element that extends from the center of a hole of one face/body to the center of a hole in another face/body. The centers of these respective holes are marked by a node that is established with the creation of a “spider”, or a web of elements extending from the edge of the hole and meeting in the center.

III. My Applications of NX Nastran

A. Restore Mission - Composite Flex Hose Box

My first true opportunity for application of NX Nastran to perform a structural analysis was a composite box meant to house a flex hose as part of a refueling subsystem for NASA’s Restore mission. The Restore mission is a satellite repair mission targeting satellites in the densely populated geostationary orbit. Syrus Jeanes is the leader of this particular refueling subsystem, and he introduced me to the progression of the project. At the time, the hose box was made of aluminum, with a composite box in the future plans. My role was to begin the process of designing this composite box, by modeling the box based on initial specifications and performing a modal analysis. Without the NX Nastran composite material software at hand, the material properties input were effective properties for an isotropic material.

The interior dimensions of the composite box are 36” by 24” by 1.5”. The box is constructed of two symmetrical shell-like structures, bolted together along an outer flange. The flange curves up into the top face. The box is enclosed on three of the four sides, with the fourth side containing the exit port for the flex hose, the motor which controls the hose’s in-and-out motion, and a bolted-in bend guard which the hose curves around. The flange and curved edge leading to the top face of each half is made of eight-ply thick carbon fiber, while the top face of each half has eighth-inch thick aluminum honeycomb core between the eight layers, making it a composite sandwich panel. Each shell is intended to be fabricated in a single layup, making each shell a single body. The purpose of the honeycomb core is to provide extra stiffness in the flat faces of the box, to help prevent resonance by increasing the first natural frequency, or mode, of the box. In general, increasing the stiffness of an

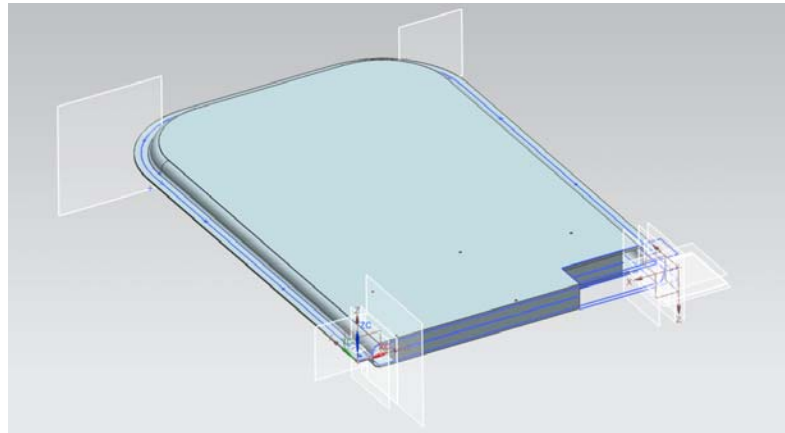

Figure 4. Composite flex hose box shown with bolt halves and sketch planes.

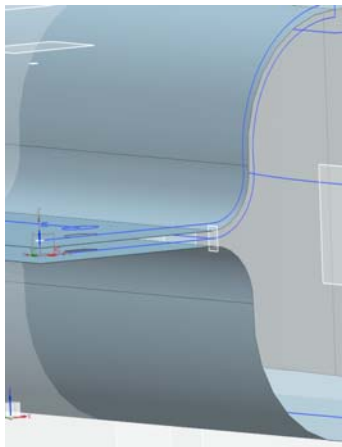

Figure 5. Midsurface of composite box (sketch shown in blue outline).

object increases the value of its first mode, making it less possible that particular mode will be reached. This is the purpose of a modal analysis: to solve the vibrational model and determine the modes of a system. The user decides how many modes the solver should determine.

An object should be modeled so that it can later be easily altered. NX has a capability known as “expressions”, which are simply variables that are assigned values and are referenced when assigning dimensions in the model. A good practice is to create a plane for every major dimension in the model, and to reference a plane for each portion of a sketch, rather than reference other sketches. When a dimension needs to be changed later on, the plane for that dimension can be moved (by simply changing the value of the expression to which it is assigned) and all sketches in the model referencing that plane should adjust accordingly.

The first simulation of the hose box was performed on only a single shell, or one half of the entire box, in order to accomplish a working model and to gain experience with a modal analysis. Being a single body comprised of two material types, the body was split in the idealized part along the interface between the two material types so that different property sets could be applied. In the .fem file for the simulation, that edge was stitched. The body was also split again on the top face, two inches inside from the edge. This was done to allow a smoother transition between the fine mesh on the curved edge to the rougher mesh on the top face, since the greatest stresses occurred at that interface.

The modal analysis was solved multiple times with differing edge constraints. The three cases of edge constraints were a completely fixed edge (as if the edges were bonded together), a 9-bolt connection along three edges, and a 12-bolt connection which constrained all four edges. Intuition suggests that the four-side constraint would offer the highest effective stiffness of the box, with the fixed constraint coming next and the

object increases the value of its first mode, making it less possible that particular mode will be reached. This is the purpose of a modal analysis: to solve the vibrational model and determine the modes of a system. The user decides how many modes the solver should determine.

An object should be modeled so that it can later be easily altered. NX has a capability known as “expressions”, which are simply variables that are assigned values and are referenced when assigning dimensions in the model. A good practice is to create a plane for every major dimension in the model, and to reference a plane for each portion of a sketch, rather than reference other sketches. When a dimension needs to be changed later on, the plane for that dimension can be moved (by simply changing the value of the expression to which it is assigned) and all sketches in the model referencing that plane should adjust accordingly.

The first simulation of the hose box was performed on only a single shell, or one half of the entire box, in order to accomplish a working model and to gain experience with a modal analysis. Being a single body comprised of two material types, the body was split in the idealized part along the interface between the two material types so that different property sets could be applied. In the .fem file for the simulation, that edge was stitched. The body was also split again on the top face, two inches inside from the edge. This was done to allow a smoother transition between the fine mesh on the curved edge to the rougher mesh on the top face, since the greatest stresses occurred at that interface.

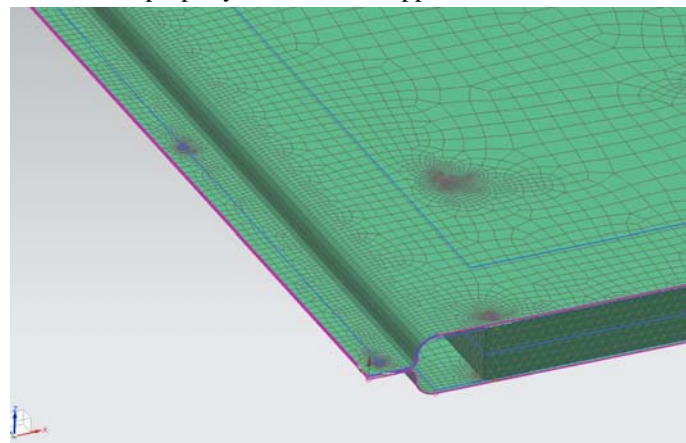

Figure 6. Mesh of box with refinements.

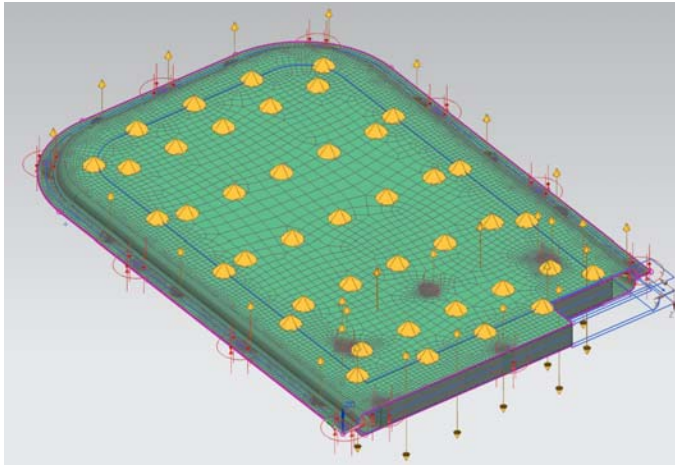

Figure 7. Box with contact surfaces and bolt pre-loads.

iterations required for contact surfaces. As a result, the strategy employed to complete the modal analysis is to first perform a stress analysis using bolt connections and a surface contact, analyze the region around each bolt that experiences significantly greater stresses than the outer area, then create a glued contact that represents that stressed region. Since glued surfaces do not require iterations, the modal analysis can be performed in this setup. The same body splitting and meshing procedures were followed for the full box as the half box, up until the bolt connection. Spider elements were created for each bolt hole on the shells, and 1D bolt connections were created. In addition to the full box setup, the aluminum bend guard was modeled and implemented into the system. The bend guard is constrained by 5 bolts which extend through the full thickness of the box from top to bottom surface. In addition to the new 1D bolt connections, surface contacts were set up between the bend guard and box on both the top and bottom faces of the box.

This analysis is currently still in progress, with the goal being the completion of a modal analysis and the subsequent adjustment of the system to reach a first mode of at least 100 hertz.

B. Orion Spacecraft – CTCS Mount

The other part on which I performed an analysis was a bracket mount for the Cabin Temperature Control Subassembly (CTCS) for the Orion spacecraft. The task was presented to me by Mr. Jose Mayi-Rivas. The CTCS, specified by the supplier, must be kinematically mounted to reduce the force it experiences. Each bracket attaches a strut to the CTCS. The bracket was previously modeled, but had to be analyzed and iterated upon to meet flight hardware structural safety factors.

For the analysis, 48 specific load cases were provided. These load cases reflect the worst-case scenario loads, which occur during an on-pad abort. With the bracket being bolted to the structural barrel, the back face of the bracket lies flat against the surface of the barrel. Picturing the bracket as either being pushed into or pulled away from the barrel (positive or negative z-component forces), the constraints must be setup differently for each of these scenarios. In the push case, the back face of the bracket is constrained so as to resist movement perpendicular to the face plane. In the pull case, however, this constraint does not exist. This constraint

three-side bolt constraint coming third. The modal analysis supported this intuition, providing magnitudes of first modes that were directly related to the stiffness order.

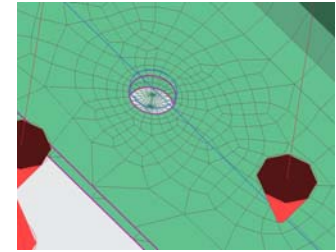

Figure 8. Spider mesh with 1D bolt connection.

Having some experience with the modal analysis, the other shell of the hose box was added into the model. The faces of the flanges were not fixed to each other, but aligned to the same plane to be connected by bolts in the future. The solver cannot perform a modal analysis simultaneously with contact surfaces and bolt connections because of the

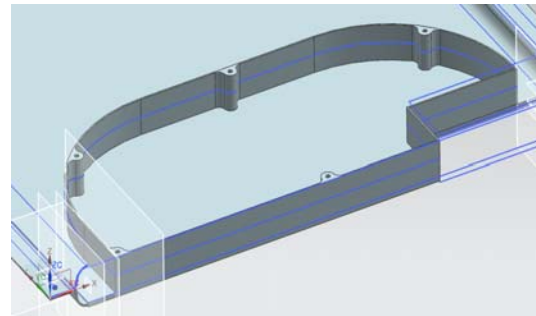

Figure 9. Aluminum Bend Guard.

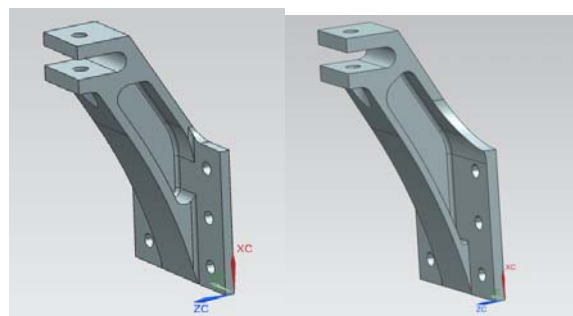

Figure 10. CTCS Mount before (left) and after (right) modifications.

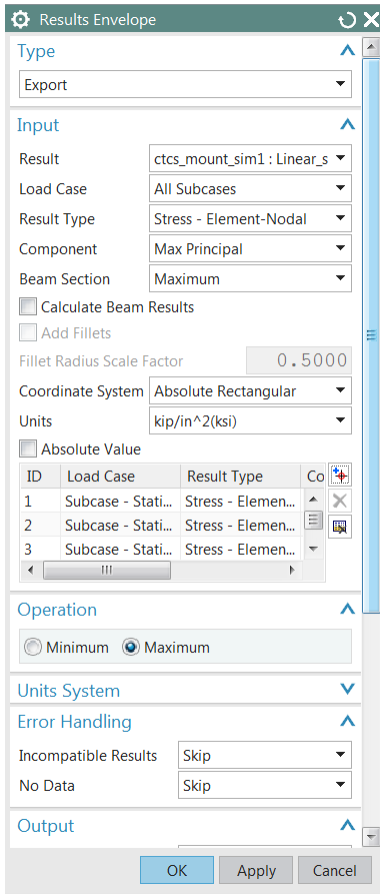

Figure 11. Envelope creation window.

setup was recognized and created by Mr. Mayi-Rivas, though it was important for me to understand before performing the iterations. In general, constraints must be considered with an intuitive mind. Half of the load cases (24) presented were pull loads; the other half were push loads. Since the constraints were different for each half, there would be two solutions under a single .sim file, each containing 24 load subcases.

Upon solving a solution, each subcase has its own set of results. Having to view each set of results individually to decide where changes can be made to the bracket can very tedious, and potentially flawed. Luckily, NX provides a feature known as “envelopes”, which allows the user to pick out important data from each subcase and combine it into a single results file. For flight hardware, safety factors to be met are 1.5 for yield and 2 for ultimate strength, whichever fails first. For this material, the ultimate failure safety factor is first to fail, which worked out to requiring a maximum principal stress equal to or less than 28.50 ksi. Thus, an envelope was created for each solution, picking the maximum values of maximum principal stress at each node of the mesh among the 24 subcases. From that point, the results can be treated as if they are a single load case, rather than 24 subcases. This is a great example of how an envelope can both save time and provide for a better analysis. A better analysis usually produces a better part.

First iterations of the bracket violated the ultimate strength safety factor. Failure tended to occur along a bend on the back face of the bracket, specifically for the push load subcases. By slowly adjusting width and thickness of this section of the bracket using synchronous modeling, safety factors were met, showing maximum principal stresses of roughly 26 ksi. Since design specifications allow for 28.50 ksi, some material could be subtracted

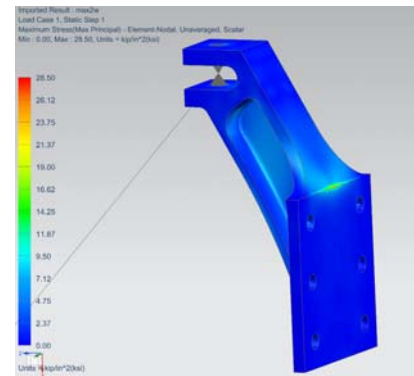

Figure 12. Bracket with maximum principal stress 28.50 ksi.

from the part. This is a situation in which a specific feature of the envelopes function becomes useful. Envelopes allow the user to include subcase ID numbers with the new results file. In other words, the user can look at the nodes that fail to meet the safety factors given, and track the failure to the subcase causing said failure. This can provide the analyst with important information about where material can be removed, by considering the load path through the part. Through this procedure, the maximum principal stress was increased to exactly 28.50 ksi (Figure 2). It is not extremely common to hit a safety factor exactly, but it is very important that the safety factor does not fail, even if slightly.

IV. Conclusion

NX Nastran is a very powerful tool with capabilities that enable the engineer to perform tasks more quickly and effectively than any other method allows. With proper handling, many real-life scenarios can be simulated to produce a variety of desired information, perhaps progressing projects forward very quickly to the prototype and test stages. However, without proper usage, the software can produce inaccurate results that cannot be trusted. Thus, it is crucial to understand the actions of the software and to investigate potential flaws in model setup. I believe I have developed a solid grasp on the implementation of NX Nastran for structural analysis, though it is a constant learning process for even the most skilled user.

Acknowledgments

I thank Mr. Syrus K. Jeanes and Mr. Jose J. Mayi-Rivas for their trust in me to complete the tasks at hand and their guidance which followed. I also thank the NE-M1 branch as a whole for their support throughout the summer, as I have learned something from every one of them.

References

¹NX, Software Package, Ver. 9.0, Siemens PLM Software, Plano, TX, 14 October 2013.

²“NX 9.0 Self-Paced Courses”, Siemens Learning Advantage, Siemens PLM Software, Plano, TX. [Referenced June-July 2014]. [https://training.plm.automation.siemens.com/mytraining/home.cfm?cmd=&details=.](https://training.plm.automation.siemens.com/mytraining/home.cfm?cmd=&details=)