

SSC14-IX-1

Expanding CubeSat Capabilities with a Low Cost Transceiver

Scott Palo
Department of Aerospace Engineering Sciences
University of Colorado
429 UCB, Boulder, CO 80309; 303-492-4289
scott.palo@colorado.edu

Darren O'Connor, Elizabeth DeVito and Rick Kohnert
Laboratory for Atmospheric and Space Physics
University of Colorado
1234 Innovation Drive, Boulder, CO 80303
Darren.OConnor@lasp.colorado.edu

Scott Schaire, Steve Bundick, Gary Crum, Serhat Altunc, Thomas Winkert
Goddard Space Flight Center
NASA
8800 Greenbelt Road
Greenbelt, MD 20771
scott.h.schaire@nasa.gov

ABSTRACT

CubeSats have developed rapidly over the past decade with the advent of a containerized deployer system and ever increasing launch opportunities. These satellites have moved from an educational tool to teach students about engineering challenges associated with satellite design, to systems that are conducting cutting edge earth, space and solar science. Early variants of the CubeSat had limited functionality and lacked sophisticated attitude control, deployable solar arrays and propulsion. This is no longer the case and as CubeSats mature, such systems are becoming commercially available. The result is a small satellite with sufficient power and pointing capabilities to support a high rate communication system.

Communications systems have matured along with other CubeSat subsystems. Originally developed from amateur radio systems, CubeSats have generally operated in the VHF and UHF bands at data rates below 10kbps. More recently higher rate UHF systems have been developed, however these systems require a large collecting area on the ground to close the communications link at 3Mbps. Efforts to develop systems that operate with similar throughput at S-Band (2-4 GHz) and C-Band (4-8 GHz) have also recently evolved. In this paper we outline an effort to develop a high rate CubeSat communication system that is compatible with the NASA Near Earth Network and can be accommodated by a CubeSat. The system will include a 200kbps S-Band receiver and a 12.5Mbps X-Band transmitter. This paper will focus on our design approach and initial results associated with the 12.5Mbps X-band transmitter.

INTRODUCTION

The University of Colorado Boulder (CU) has a long history of providing low-cost, high value satellites through student, professional and scientist collaboration to optimize the activities on every level. Examples include the Solar Mesosphere Explorer (SME) [Barth, et al, 1983; Thomas et al., 1984] and Student Nitric Oxide Explorer (SNOE) [Solomon et al., 1996; Bailey et al., 2005] satellites designed and deployed before CubeSat opportunities existed. More recently CU has embraced CubeSats which includes the very successful

National Science Foundation (NSF) [Moretto, 2008] funded Colorado Space Weather Experiment (CSSWE) [Palo et al., 2010; Li et al., 2010; 2012] which has been operating on orbit since September 2012. Upcoming CU CubeSat projects include the NASA funded Miniaturized X-ray Spectrometer (MinXSS) and the NSF funded Challenger CubeSat which is one of four US CubeSats participating in the European QB50 project to launch 50 CubeSats into low earth orbit.

The evolution of CubeSat technologies has occurred rapidly over the past 10 years and evolved from university labs and projects [Twiggs, 2008]. The early CubeSat systems utilized body mounted solar arrays, generally had no attitude control, lacked propulsion and had rudimentary communication systems based on amateur radio equipment. With increasing flight opportunities for CubeSats the technology has evolved quickly with high precision attitude determination and control systems (see <http://bluecanyontech.com>), deployable solar arrays (see <http://www.clyde-space.com> and <http://www.mmadesignllc.com>) and small propulsion systems (see <https://www.rocket.com/cubesat>) now available. Communication systems have also evolved from the early 1200bps amplitude shift keying (ASK) systems to 3 Mbps quadrature phase shift keying systems which also include forward error correction coding. One of the challenges in moving forward with CubeSat communication systems is not just the availability of flight hardware but also the compatibility with ground system technology and spectrum allocation. The Federal Communication Commission (FCC) and the International Telecommunications Union (ITU) strictly control the allocation and use of the radio spectrum which is becoming increasingly crowded. One must be cognizant of the available radio service, bandwidth and power density limitation when considering a radio design [Klofas 2013].

The lack of high rate radios that fit into the CubeSat form and power envelope will limit the future potential of these systems to conduct compelling science. While the L3 UHF Cadet radio is compatible with the CubeSat operational envelope and can achieve 3Mbps in the 460-470MHz band [Kneller et. al., 2012], which is available for space-to-ground communications, the maximum power flux density at the ground requires the use of a large 20m class antenna to close the link at these data rates. The most obvious approach is to move up in frequency to S-Band (2-4 GHz), C-Band (4-8 GHz) X-Band (8-12 GHz) or the K-Bands (12-40GHz) where antenna apertures become smaller for a similar gain. Note that this nomenclature comes from the IEEE 521-2002 Standard on Letter Designations for Radar-Frequency Bands. The selection of an operational band is limited by the FCC/ITU regulations, primary band users and the availability of robust inexpensive technology, however there is spectrum available in all of these bands for ground-to-space and space-to-ground satellite communications.

Recently, the Laboratory for Atmospheric and Space Physics (LASP) at CU partnered with a commercial company GeoOptics, Inc., in an effort to develop a low cost satellite. The goal of this joint venture was to

demonstrate the viability of collecting GPS occultation data to substantially improve weather forecasting, hurricane track modelling, and to monitor properties of the ionosphere and providing a commercially available near real-time data product. The volume and application of data was well suited for use of the Earth Explorer Satellite Service spectrum in the 2025 to 2110 MHz S-Band uplink and 8025 to 8400 MHz X-Band downlink regions. While investigating radio options for the satellite, LASP engineers and students also considered the possibility of designing their own low cost transceiver. The recent availability of commercial Monolithic Microwave Integrated Circuits (MIMC's) for radio frequency (RF) circuit design in these frequencies presented an opportunity.

A two stage upconverter for an X-Band transmitter implementing QPSK modulation was breadboarded using evaluation boards and showed promise. Using these results a paper design was developed capable of meeting the link budget, power limits, and form factor constraints for a low cost CubeSat radio with downlink data rates on the order of 10 Mbps. Elements of the design were optimized using 3D electromagnetic simulation tools to guide the layout. A prototype system was constructed where intermodulation distortion products were observed and proved difficult to eliminate. This effort showed that the design was feasible and led to a new single up-converter design.

CU is continuing to advance the transceiver design under a SmallSat Technology Partnership award (NNX13AR01A), working with NASA engineers at Goddard, Wallops and Marshall Research centers. Student participation is also being leveraged to speed the development of an S-Band receiver through a proof of concept design being done as part of a senior project course. Herein we discuss the lessons learned from the initial prototype; how those lessons led to changes to the original design; and the basic but inexpensive capabilities expected of the initial radio. Future capabilities will be enabled through the inclusion of highly underutilized FPGA's in the design, providing, e.g., the ability to add more advanced error detection and correction coding to the data streams. The architecture can expand to handle data rates on the order of 100 Mbps and to operate at other frequencies. In fact, this research paves the way for even higher data rate cube/small satellite communications. Although this work mainly focuses on X-Band transmit capabilities, in the future this architecture can be extended to cover Ka-Band (25.5-27 GHz) to address future needs of NASA, other government agencies, universities and industry since NASA is investigating enhancements to its space communication capabilities

to provide Ka band ground systems for next generation missions in the near Earth regime.

The development of this low cost communications technology will lead to advances in the capabilities of both commercial and scientific CubeSats. Coupled with other recent advances, such as arc-second pointing capabilities, increased data rates for CubeSats will provide a growing platform for universities and private businesses to do cutting edge missions. These include imaging, GPS occultation, and even global communications links for ground based science that could be enabled at low cost using CubeSats with high data rate capabilities.

CUBESAT COMMUNICATIONS

The growing acceptance of secondary payloads by launch providers has significantly increased the access to space for small satellites over the past decade. The modularity and reduction of risk to the primary mission from an entirely enclosed “jack-in-the-box” type deployer has rapidly increased the launch rate for CubeSats. Numerous recent CubeSat missions funded by the National Science Foundation, including RAX [Moretto, 2008; Springman et al., 2012; Bahcivan et al., 2012], DICE [Crowley et al., 2011] and CSSWE [Palo et al., 2010; Li et al., 2010; 2012] have clearly demonstrated the ability to conduct cutting edge science measurements using a CubeSat. In fact CSSWE has a high energy particle telescope that is providing correlative science measurements supporting the NASA Van Allen probes mission [Baker et al, 2013].

A recent paper by Klofas and Leveque [2013], shows that most CubeSats don't get more than a few MB downloaded over the course of a mission. The exceptions are the recent CSSWE and RAX-2 missions which collected over 60 and 242 MB respectively using a 9600 bps AstroDev UHF Lithium radio in addition to the DICE mission which has downloaded over 8GB, using the L3 UHF Cadet radio and the large 60 ft receiving dish at the NASA Wallops Flight Facility (WFF).

Many recent CubeSats have made use of frequencies allocated for amateurs, while government funded CubeSats using amateur radio frequencies may violate the intent of the amateur radio service. Additionally, it is a violation of National Telecommunications Information Administration (NTIA) rules for government funded ground stations to use amateur radio frequencies to communicate with CubeSats. With the significant growth of CubeSat missions the current use of amateur spectrum is not sustainable and alternative solutions need to be developed. Such solutions require the development of radios in other

bands that can be licensed and which are affordable, meet CubeSat constraints and can provide high speed downlinks.

As described earlier, many sophisticated satellite instruments such as hyperspectral imagers, require high volumes of data. CubeSat designers have used innovative techniques such as pre-processing, quick look, and lower resolution to operate within the constraints of lower data rates. These techniques result in tradeoffs of additional power, additional complexity, and unfortunately, lower science return. The bottom line is that because of low data rates, the science return “bang-for-the-buck” is much lower than it could otherwise be with higher data rate solutions. This applies to all of the NASA sciences: Heliophysics, Planetary, Astrophysics, and Earth Science. Deployable solar arrays and increased pointing capabilities for CubeSats are enabling the potential to support higher data rates communication systems. The key now is to develop a communication solution that maximizes data rate versus cost, mass, volume, and power to meet this need.

NASA GSFC WFF has designed, developed and fabricated a 6U CubeSat with an S-band communications system and dedicated the antenna portion of the 18.3 m UHF-band ground station to the small satellite community. WFF is currently working on a CubeSat frequency standardization effort which includes categorizing existing CubeSat communication systems, especially radios and ground station solutions, performing trade studies of UHF-, S- and X-bands, and recommending the future direction and bands for CubeSat communication. One of the main goals is to standardize CubeSat flight and ground communications hardware systems and the frequency utilization of CubeSats, thereby reducing the amount of time and cost required to obtain frequency authorization. Additionally, GSFC/WFF designed the existing NASA Near Earth Network (NEN) X-band ground system which is standardized. Our vision is to design a standardized flight transceiver (S/X-band) compatible with the NEN that will enable future NASA science missions.

HIGH RATE CUBESAT COMMUNICATION SYSTEM (HRCCS)

Recent advances in RF technologies are enabling the development of radio transmitters and receivers using integrated 50 ohm matched components. These advances have pushed into the X-Band portion of the RF spectrum and make the design and development of an X-Band transmitter for CubeSats a viable option. Operating at higher frequencies where such components are not available requires extensive RF design skills and

tools to match impedances between components in the signal chain. This process requires expensive design software, testing equipment and many hours of effort by an experienced RF design engineer.

Design Approach

The University of Colorado approach to designing an HRCCS is in-line with our CubeSat system development philosophy. Our approach is to leverage COTS development, minimize the design and analysis cycle through a tightly coupled iterative design process that includes early prototyping and testing.

Our approach for the radio is to design a modular system that includes an S-Band receiver module, an X-Band transmitter module and a power distribution module. Currently the frequency control between the receiver and transmitter are decoupled, however frequency synchronization between the two systems may be considered in future revisions of the design.

The HRCCS design effort is split over multiple years. The first year is focused on developing the X-Band transmitter and moving the technology readiness level of this system element from TRL-3 to TRL-5. Our current plan then focuses on maturing the technology readiness level of our S-Band receiver from TRL-3 to TRL-5 in year two and then integrating the elements in subsequent years. However there has been strong interest in maturing the X-Band transmitter design moving towards a flight verification of the basic unit in year two.

System Consideration

CubeSats provide a challenging environment for the spacecraft systems engineer. The orbital average power is typically low, for example body mounted 3U 28% efficient solar cells can provide about 7W of DC power at 28C while a 6U panel can provide 18W. The small volume and hence surface area also make thermal design challenging as well. Both of these elements come into consideration when designing the communications system.

Recent advances in RF design have now made monolithic 50 ohm components available in the X-Band range and higher. For example, X-Band power amplifiers can attain 31dBm (1.3W) output with a 23% PAE. This results in a 5.7W DC power requirement and 4.3W of heat dissipation. This level of DC power and heat dissipation is achievable for the typical 3U CubeSat configuration. Higher power X-Band amplifiers operating at 40dBm (10W) with a 22% PAE are also recently available. These amplifiers require 44W DC to achieve 10W RF output and dissipate 34W of heat. While these amplifiers are likely not applicable

to standard 3U CubeSats, it is possible that 6U systems may be able to accommodate such systems.

X-Band antennas currently exist in form factors compatible with CubeSats. One example is the AntDev micropatch antenna (see www.antdevco.com). The antenna has a 20MHz bandwidth, 70 degree half-power beamwidth with a 6dBi gain, can handle 10W continuous power and fits into a 2.0"x2.0" form factor.

Given the availability of high performance attitude control systems, such as the Blue Canyon XACT ADCS (see www.bluecanyountech.com) the use of directional antennas for downlink should be considered. Assuming a 6U CubeSat with a 50% efficient antenna utilizing a 20cmx20cm physical area results in a 0.04 m² effective aperture. Using the relationship between antenna gain and effective area yields

$$G = \frac{4\pi}{\lambda^2} A_e$$

a gain of 26dB. The resulting beamwidth for a symmetric circular aperture can be approximated using

$$\theta = \sqrt{\frac{4\pi}{G}}$$

and results in $\theta = 0.177$ radians (10.2°). With sub-arcminute attitude control systems now available, the use of high gain antennas on a 6U CubeSat is a possibility and could achieve gains of better than 20dB.

NASA Near Earth Network

The NASA Near Earth Network (NEN) is an organization that provides communication services to space assets. The NEN is an element of the NASA Space Communications and Navigation (SCaN) program office which also includes the Deep Space Network (DSN) and the Space Network (SN). The NEN provides telemetry, commanding and tracking services for orbital and suborbital missions in low earth orbit, geosynchronous orbit, highly elliptical, Lagrange and Lunar orbits. The NEN capabilities include UHF, VHF, S-Band, X-Band and Ka-Band. The NEN maintains NASA run ground stations in the United States (Virginia, New Mexico, Florida and Alaska) in addition to international sites at (Norway and Antarctica). More details about the specific details of the NEN, including supported modulation schemes can be found in Near Earth Network Users Guide (453-NENUG).

Link Budget

To determine the viability of a communication link one needs to compute the link budget. Key elements of the link budget include the operating frequency, satellite system elements (transmitted power and antenna gain), the ground station performance (antenna gain and receiver noise figure). Table 1 summarizes the link budget for a CubeSat in low earth orbit operating at 8380MHz in the Earth Explorer Satellite Service. For simplicity a 1W (0dBW) transmitter operating with an omni directional antenna (0dBic) is utilized for this example. Assuming 0.4dB of system losses between the transmitter and the antenna results in a -0.4dB effective isotropic radiated power (EIRP). At a range of 2566km the power flux density (PFD) at the surface of the earth is -141.57 dBW/m². Using a nominal NEN ground station, with an 11.28m dish, results in a received signal power of -94.53dBm. Accounting for the ground station noise temperature and the background noise temperature results in a carrier-to-noise ratio of 81.28 dB-Hz. Operating at a data rate of 12.5Mbps without encoding requires 12.5MHz of bandwidth (70.96dB-Hz⁻¹). The resulting received energy per bit is

$$\frac{E_b}{N_o} = \frac{C}{N_o} B$$

$$\text{thus } \frac{E_b}{N_o} = 81.28 - 70.96 = 10.23\text{dB}$$

Table 1: Downlink Budget (X-Band)

Parameter	Value
Frequency	8380 MHz
Transmitter Power	1W, 0dBW
System Losses	0.4dB
Transmit Antenna Gain	0dBic
EIRP	-0.4dBW
Range	2566km
Spreading Loss+Atm Attenuation	-141.17 dB/m ²
PFD at Earth	-141.57 dBW/m ²
Space Loss	-119.1 dB
Receive Antenna Diameter	11.28m
Receive Antenna Efficiency	57%
Receive Antenna Effective Area	17.55 dB-m ²
Receive Antenna Gain	57.47 dBic
Received Signal Power	-94.53 dBm

Receive Station G/T	34.69 dB/K
C/No	81.28 dB-Hz
Data Rate	12.5Mbps
Received Energy Per Bit, Eb/No	10.32 dB
Required Eb/No for OQPSK with 1E-6 Bit Error Rate (BER)	5.52 dB
Link Margin	4.79dB

The required E_b/N_o to achieve a bit error rate of 1E-6 using convolutional encoding is 5.52dB. Using the described operating parameters there is a 4.7dB link margin indicating that the proposed system architecture is feasible. If additional range is desired, say 2x, that would reduce the link margin by 6dB. This could be offset by an increase in the satellite antenna gain or the transmitter power, however increasing the transmitter power comes at a cost to the power budget because the X-Band transmitters are typically only 20-25% efficient.

Requirements

To begin the design process we developed a set of key requirements which are listed in Table 2. Our goal is not to make a complex radio driven by many requirements that drive the cost up, but rather have taken a COTS type approach. It is important in this first generation to keep the cost and complexity of the design to a minimum.

Table 2: Key HRCCS Requirements

Requirement
The radio system shall be compatible with the NASA Near Earth Network.
The system shall operate between -20C and +50C.
The system shall be compatible with a 3U CubeSat.
The system shall operate for 12 months in low earth orbit.
The transmitter shall be capable of transmitting 12.5Mbps.
The transmitter shall have sufficient power to close the communication link between the NEN and low earth orbit.
The receiver shall be capable of closing the communication link between the NEN and low earth orbit.
The transmitter shall be capable of supporting OQPSK modulation.
The transmitter shall be capable of forward error correction coding.

Downlink Block Diagram

Figure 1 shows the major components of the single stage upconverter. An FPGA is used to take in a data stream or to generate a random test pattern, divide the data stream into I and Q channels, and generate a

convolutional code for error detection and correction. The encoded I and Q channel data is output to a pair of sixth order analog lowpass filters to limit the baseband signal bandwidth. The filtered channel data are then fed to the intermediate frequency (IF) inputs of the upconverter mixer, along with the carrier frequency. The modulated output is amplified and filtered to generate a transmit-ready, 1 Watt OQPSK signal for delivery to an antenna.

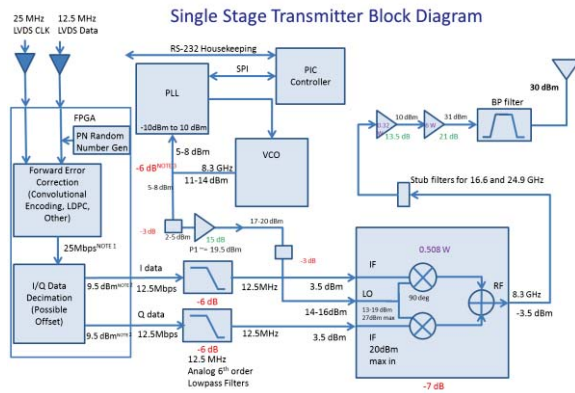

Figure 1: Single Stage x-band transmitted block diagram

X-band Transmitter Simulation

A Simulink model of the single stage upconverter was created to investigate the impact of bandwidth filtering on link budget degradation (see **Figure 2**). Such filtering is required to meet the emission limits defined by the Space Frequency Coordination Group [SFCG, 2013], seen in **Figure 5**. Modeling the suggested sixth order Butterworth filter with a 12.5 Mbps data rate produced a 1 dB increase in the E_b/N_0 required for a $1E-6$ bit error rate. The model result was later verified using prototype hardware, where a 1.2 dB loss was measured when the filter was added to the signal path (see **Figure 7**).

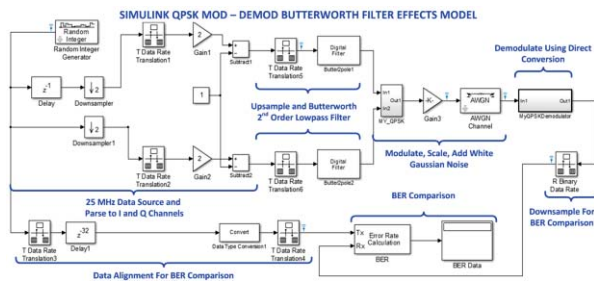

Figure 2: Mathworks Simulink system simulation

DESIGN APPROACH

We have chosen to use COTS devices possessing 50 Ohm input and output impedances for the RF signal chain. This choice limits the need for time consuming impedance matching, though some effort has been devoted to minimal optimization, e.g., trace lengths between devices. Use of co-planar waveguide dimensions matching that of manufacturer's evaluation board designs, which were also simulated in electromagnetic (EM) 3D field solvers (discussed next), reduced risk of poor impedance matching. These design choices have enabled us to work at more of a system level. Time has been spent, however, using simulation tools to help analyze the sometimes unexpected results seen in the earliest prototype.

In addition to simulations to inform the design effort, prototyping of as much of the system as possible using evaluation boards has given us confidence that the design will work. The schedule and budget have also been set up to allow for testing of a first prototype, followed by a second that addresses unexpected behaviors in the first.

Tools

We have used two different 3D EM field solvers to simulate the RF signal chain: AWR Microwave Office and Mentor Graphics (MG) Hyperlinx 3D EM. We have learned to import S-parameter models into AWR and perform system level simulations with the tool, including geometry effects. In MG's tools we have only been able to model ideal passive components and geometry effects, so it has not yet been as useful. Some prototype circuits have been built at this point, allowing the simulation results to be verified, with good agreement seen between lab results and simulations shown in **Figures 3** and **4**.

Matlab and LTSpice have also been used for system level and initial circuit designs. The latter provides a much faster path to basic circuit simulation than the EM tools and has also provided a means of verification that the EM tools were being used correctly, e.g., by simulating circuit responses, without geometries included, in the EM tool simulations and comparing with the LTSpice results.

Simulation Results

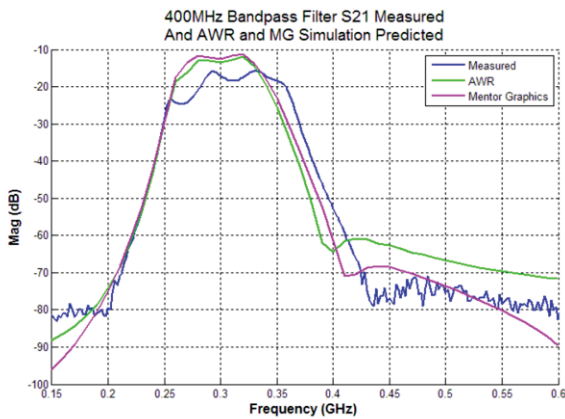

Figure 3: Comparison of the measured (blue) and simulation results from the Mentor Graphics (magenta) and AWR (green) RF design tools.

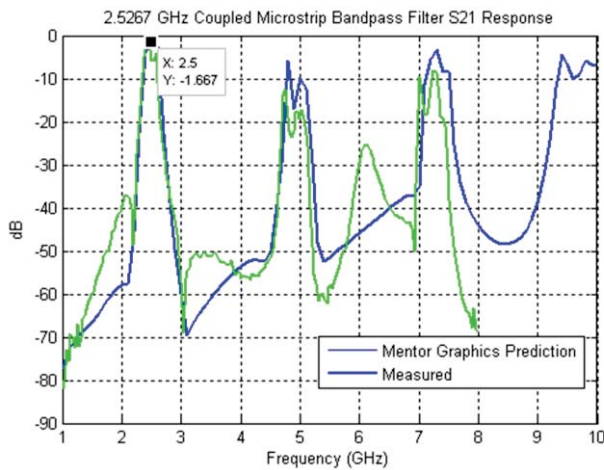

Figure 4: Comparison of measured (green) and Mentor Graphics (blue) predicted performance of a 2.5 GHz coupled microstrip bandpass filter

INITIAL PROTOTYPE TESTING RESULTS

A great deal of confidence in the design and models was sought and achieved by using evaluation boards to test much of the system of **Figure 1**. The evaluation boards and a custom analog baseband filter board were sent to GSFC for testing. GSFC lab equipment provided an 8.2 GHz carrier input and measured the spectral output of the system as seen in **Figures 5** and **6**. Testing showed some initial problems with the AC coupling methods used in the filter, driving a small design change.

After adjusting the filter design, the output spectrum was very much as expected and the final output was seen to meet the SFCG spectrum emission limits as

seen in **Figure 5**. The benefit of using a single stage upconverter is seen in **Figure 6**: the first undesired spurious signal occurs at twice the carrier frequency, making its attenuation a simple task.

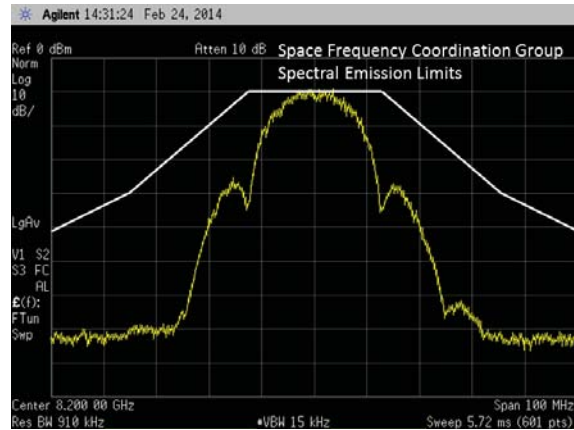

Figure 5: Output spectrum of HRCCS x-band transmitter centered at 8200MHz with 100MHz span. Mask is the space frequency coordination group spectral emission limit mask.

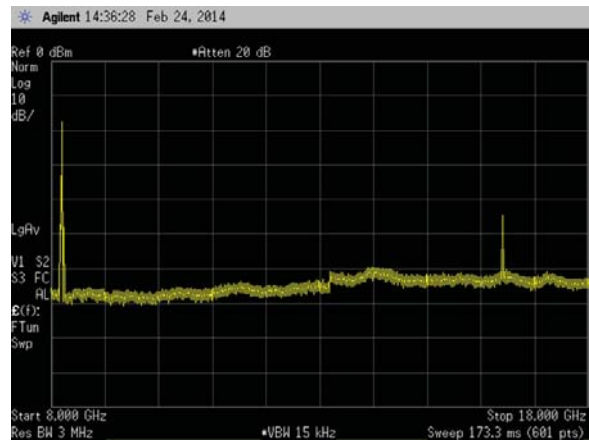

Figure 6: Output spectrum of HRCCS x-band transmitter spanning 8000 to 18000MHz without output filtering. The fundamental and the first harmonic are visible.

During prototype testing, BER performance with and without baseband filtering was measured. **Figure 7** shows that use of the sixth order Butterworth filters required a 1.2 dB increase in Eb/No to maintain a 1E-6 BER. This closely matched the predictions of the Simulink model, with the small difference from the model perhaps the result of non-ideal filters and their mismatch in the I and Q channels, as well as mismatches in the upconverter mixer I and Q input responses.

Measured BER vs Eb/No (dB) For QPSK (Blue), QPSK with Encoding (Green), and With Encoding And 6th Order Butterworth Filtering

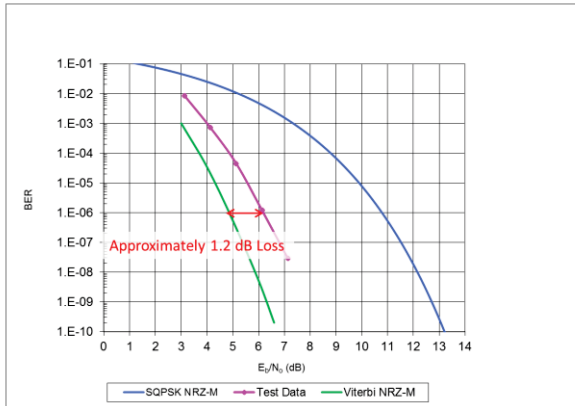

Figure 7: Measured bit error rate performance of HRCCS prototype x-band transmitter with convolutional encoding and 6th order Butterworth filtering.

With these good results in hand, the design and layout of a custom prototype continued. The addition of the phase locked loop network, FPGA, and power supply circuits constitute major differences from the tested circuitry. The first prototype board in its assembled state is seen in **Figure 8**. The board dimensions are nearly compatible with a 1U CubeSat form factor at 9.8 x 9.0 cm, with some test points in the first prototype to be removed in the subsequent, final design.

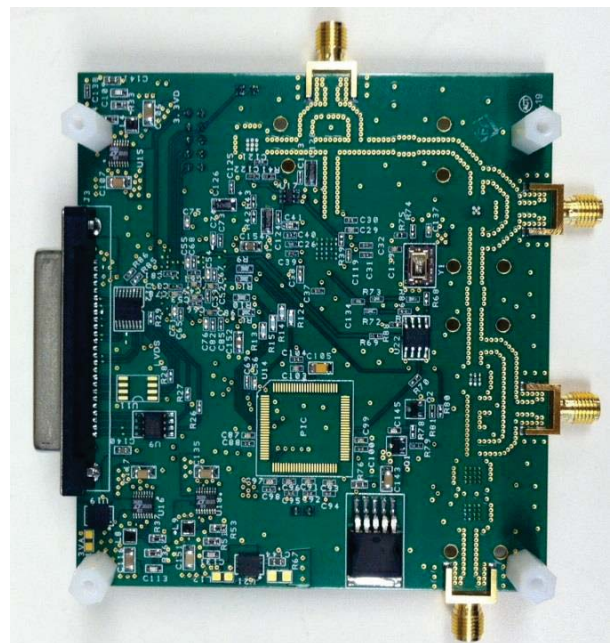
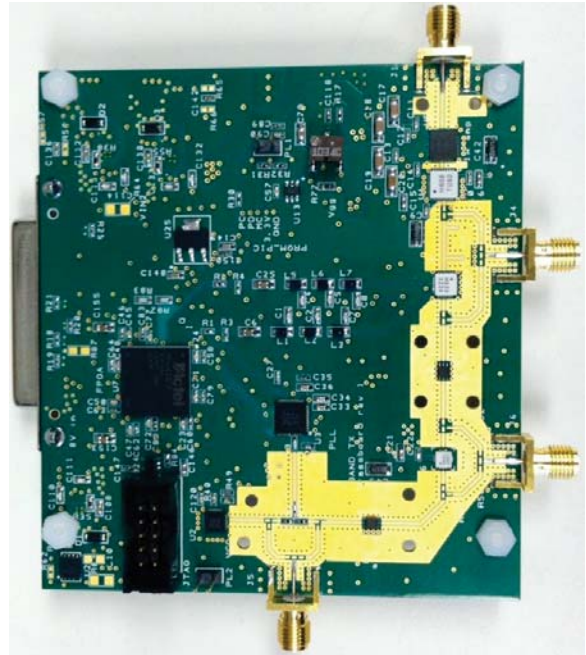

Figure 8: HRCCS x-band transmitter prototype module top and bottom view.

NEXT STEPS

The objective of our Small Satellite Technology Partnership project was to raise the technology readiness level a high rate CubeSat communication that is compatible with the Near Earth Network from TRL-3 to TRL-5 in two years. After 9 months of effort, we are approaching our goal of TRL-5 for the X-Band

transmitter. Functional testing is currently underway and demonstration of the X-Band transmitter is expected to occur in a thermal vacuum chamber in the next three months. The original plan was to focus on the development on the S-Band receiver which is compatible with the NEN in the second year of the project. Initial prototyping of the S-Band receiver has occurred at the Goddard Space Flight Center and during the 2013-14 academic year a team of 5 electrical engineering students worked on a prototype receiver for their senior project. These initial efforts have given us confidence that the construction of a CubeSat and NEN compatible S-Band receiver is feasible. However there has been interest expressed in accelerating the development of the X-Band transmitter to further increase the TRL. Our plan for the second year of the project is being discussed and the priorities are still to be determined.

CONCLUSIONS

High rate communications, especially for data downlink, is a key technology necessary to enable future CubeSat science missions. Three 7 minute passes each day results in the ability to downlink 1GB per day. With the advent of commercially available Monolithic Microwave Integrated Circuits (MMICs), the design and construction of a CubeSat compatible X-Band transmitter is feasible and cost effective. Our team has embarked down the path to developing such a transmitter that is compatible with the NASA Near Earth Network. Our approach has been to limit complexity, test prototypes early in the design process and utilize RF design tools where available. The first version of the system has been designed, fabricated and is currently undergoing functional test followed by testing in a relevant environment. By the end of the first year of the project (September 2014), we expect to have an X-Band transmitter capable of operating at 12.5Mbps to TRL-5.

Acknowledgements

The authors would like to acknowledge the support of our colleagues Scott Schaire, Steve Bundick, Gary Crum, Serhat Altunc, Brenda Dingwall, Thomas Winkert at the NASA Goddard Space Flight Center, Eric Eberly, Kosta Varnavas, Herb Sims at the NASA Marshall Space Flight Center, Courtney Duncan, Jim Lux and Jan Tarsala at the Jet Propulsion Lab and Greg Dorais at the Ames Research Center. This effort is supported by the NASA Small Satellite Partnership Cooperative Agreement Grant # NNX13AR01A entitled "High Rate CubeSat X-band/S-band Communication System".

References

1. Twiggs, B., Small Satellites: Past, Present, and Future, chapter Origin of CubeSat. American Institute of Aeronautics and Astronautics, Inc. 2008.
2. Moretto, T., "CubeSat mission to investigate ionospheric irregularities", Space Weather, 6(11), 2008.
3. Handbook of the Space Frequency Coordination Group Recommendation 21-2, https://www.sfcgonline.org/Public%20Documents/SFCG_Handbook_2013.pdf, pg. 207
4. Barth, C. A., Rusch, D. W., Thomas, R. J., Mount, G. H., Rottman, G. J., Thomas, G. E., ... & Lawrence, G. M. (1983). Solar mesosphere explorer: Scientific objectives and results. Geophysical research letters, 10(4), 237-240.
5. Thomas, R.J., Barth, C.A., Rusch, D. W., & Sanders, R. W. (1984). Solar Mesosphere Explorer Near-Infrared Spectrometer: Measurements of 1.27- μm radiances and the inference of mesospheric ozone. Journal of Geophysical Research: Atmospheres (1984–2012), 89(D6), 9569-9580.
6. Solomon, S. C., et. al., (1996). The student nitric oxide explorer. In Proc. SPIE Int. Soc. Opt. Eng (Vol. 2810, p. 121).
7. Bailey, S. M., Merkel, A. W., Thomas, G. E., & Carstens, J. N. (2005). Observations of polar mesospheric clouds by the Student Nitric Oxide Explorer. Journal of Geophysical Research: Atmospheres (1984–2012), 110(D13).
8. Kneller, E., K. Hyer, T. McIntyre, D. Jones and C. Swenson (2012). Cadet: A high data rate software defined radio for smallsat applications. Proceedings of the 2012 AIAA Small Satellite Conference, Logan UT.
9. Klofas, B. (2012). CubeSat Frequency Allocation. 2012 CubeSat Developers Workshop, San Louis Obispo, CA.