



The Effect of Indenter Radius on the Static Load Capacity of the Superelastic 60NiTi for Rolling Element Bearings

Christopher DellaCorte

NASA, Glenn Research Center

And

Lewis (Chip) E. Moore III and Joshua S. Stinton

NASA Marshall Space Flight Center

69th STLE Annual Meeting & Exhibition

May 20th, 2014

Lake Buena Vista, Florida



Motivation: the ride into space can be rough

(Vibration/loads impact bearings and components)

- Bearing and component materials must be:
 - Hard (Rockwell C58 or better)
 - Wear-resistant and compatible with existing lubricants
 - Resistant to rolling contact fatigue (RCF)
 - Fracture resistant
 - Corrosion resistant (preferably immune)
 - Low density (to reduce centripetal loads at high rpm)
 - Capable of producing ultra-smooth surface finishes
 - Dimensionally stable and easy to manufacture

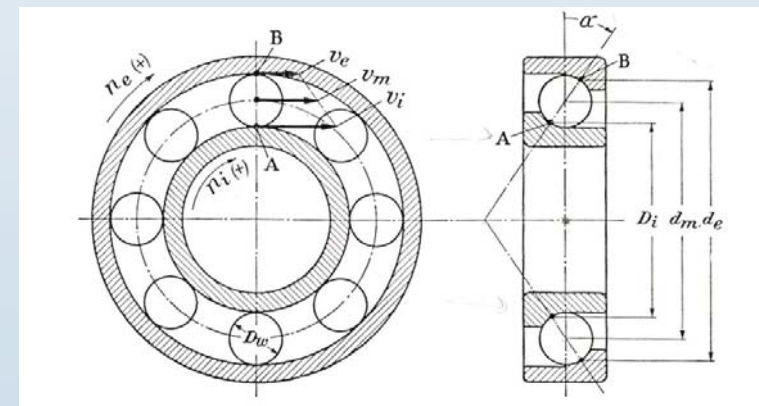



Contact Engineering: Ball-Race

- When hard surfaces contact
 - Forces are transmitted at small, concentrated contact points (Hertz).
 - Resulting stresses cause deformations that help “spread the load”.
 - Contact area is a function of the geometry, material stiffness and load.
 - High stiffness (modulus) inhibits deformations leading to small contact area and high stresses (contrast with a tire contacting the ground).

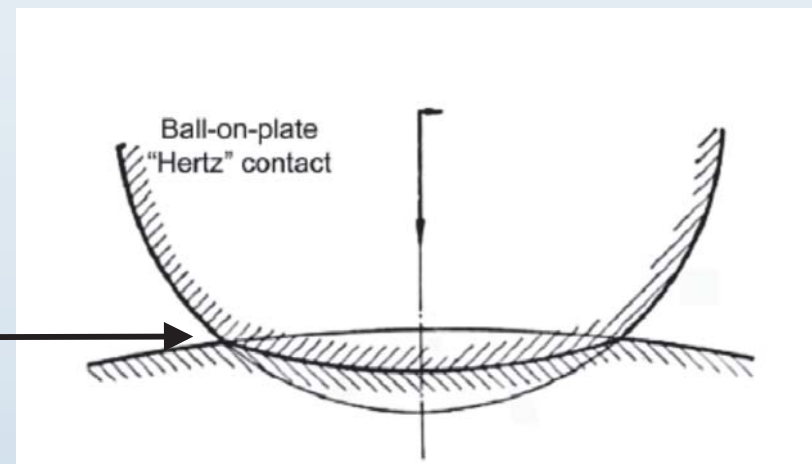
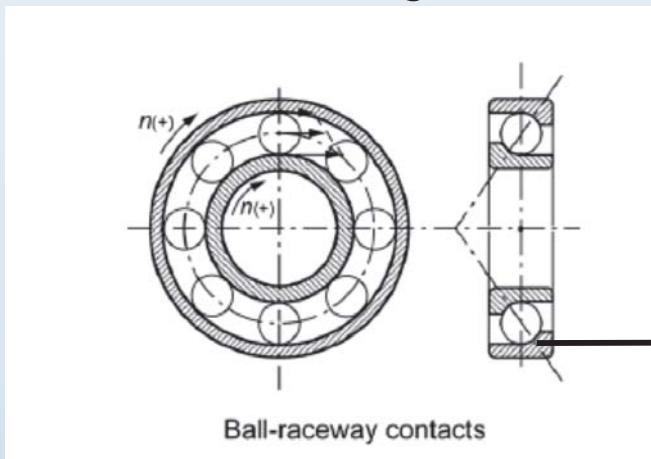

- *Hard surfaces can dent*
 - *Even modest loads can exceed stress capability limits.*
 - *Bearing raceways are particularly prone to Brinell dent damage.*



Ball-Race Static Load Capacity: Leveille & Murphy (Dent depth vs. running torque noise)

- Classic 1973 paper on dent depth/ball diameter (d_p/D) effects
 - Showed that $d_p/D \sim 0.0001$ criterion too aggressive for precision bearings with respect to torque ripple. Proposed $d_p/D \sim 0.00003$ to 0.00005

DETERMINATION OF THE INFLUENCE OF STATIC LOADS
ON
THE OUTPUT TORQUE OF INSTRUMENT BALL BEARINGS

ALAN R. LEVEILLE
JOHN J. MURPHY

Presented at the
CHARLES STARK DRAPER LABORATORY
INTERNATIONAL BALL BEARING SYMPOSIUM

JUNE 5, 1973

THE BARDEN CORPORATION
DANBURY, CONNECTICUT

Torque Ripple vs. dent depth

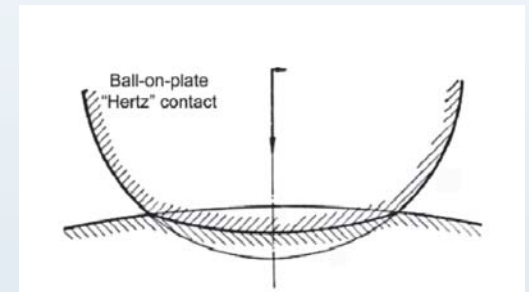
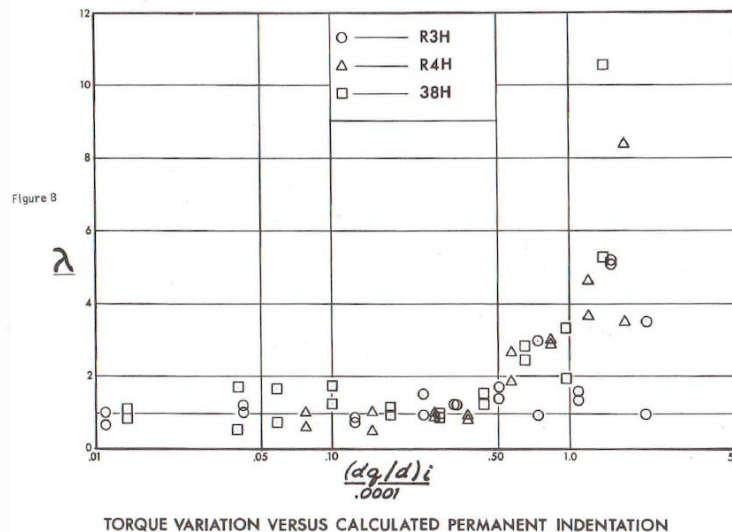

Dent depth vs. hertz stress

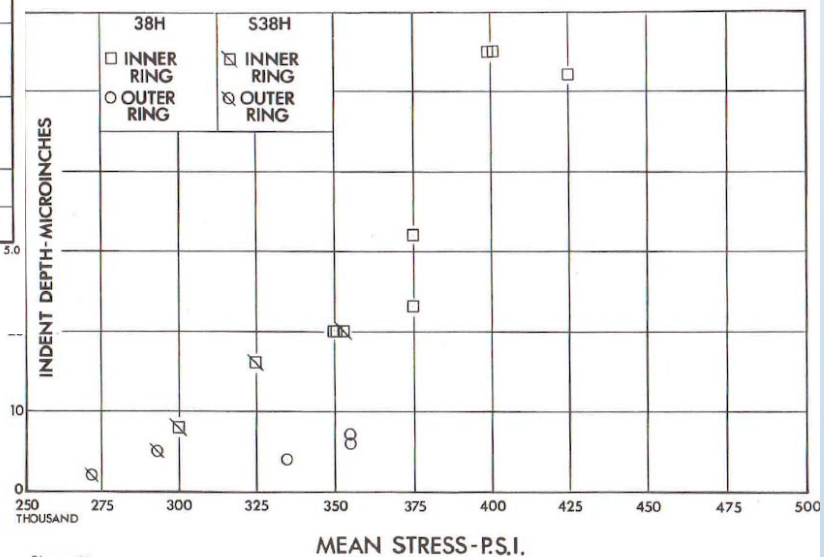



Contact Engineering: Geometry, Loads and Materials

- Engineering Mitigations

- Reduce loads through vibration isolation.
- Reduce the stresses through margin additions such as increased bearing size and increased ball-race conformity.
- Use harder materials less prone to denting.

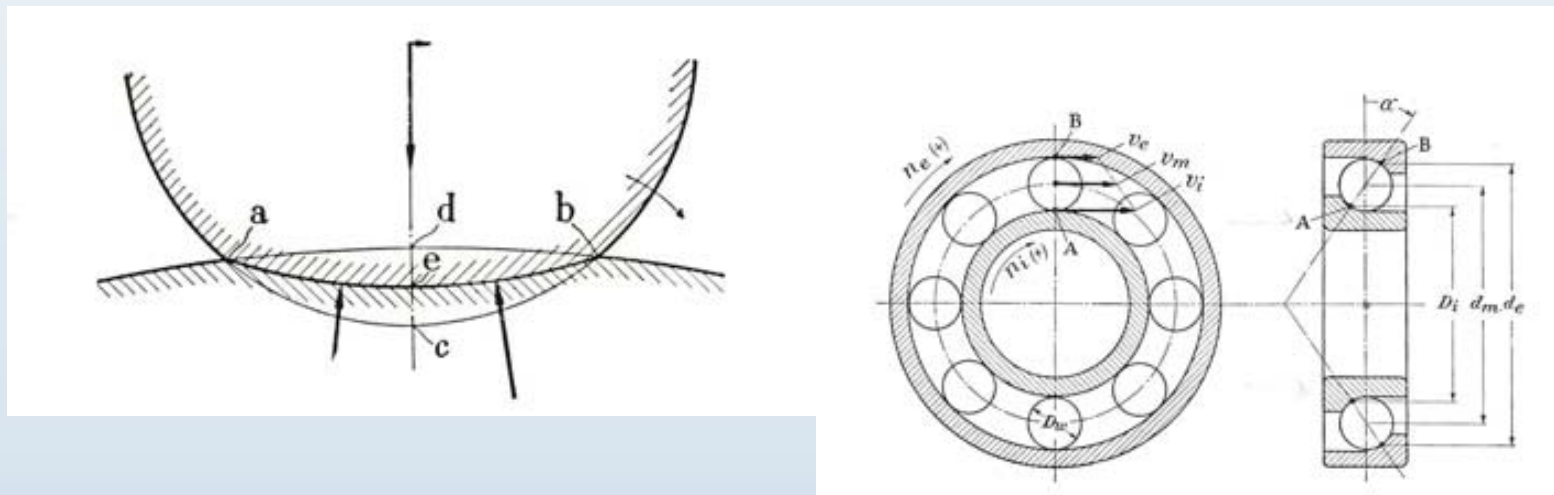

- *Implications*

- *Load reduction and vibration isolation can add mass.*
- *Bearing design and material changes introduce other complications.*



Bearing Material: State-of-Art (SOA)

(Current suite of candidates is severely limited)

- Four general types of bearing materials:
 - Steels (Corrosion resistant steels, martensitic, austenitic)
 - Ceramics (Si_3N_4 balls + steel races, a.k.a., hybrid bearings)
 - Superalloys (e.g., jet turbine blade alloys)
 - Non-ferrous alloys (bronze, nylon etc.)
- Each of these has inherent shortcomings:
 - Hard steels are prone to rusting (even “stainless steels” like 440C)
 - Superalloys and austenitic stainless steels (304ss) are soft.
 - Ceramics have thermal expansion mismatch and dent steel races
 - Non-Ferrous materials are weak and lack temperature capabilities
- No known bearing material blends all the desired attributes:
 - High hardness, corrosion immunity, toughness, surface finish, electrical conductivity, non-magnetic, manufacturability, etc.



New approach: 60NiTi-Superelastic

(Hard but resilient material based upon shape memory alloys)

- 60NiTi Basics: market name NiTiNOL 60
 - Invented by W.J. Buehler (late 1950's) at the Naval Ordnance Laboratory (NiTiNOL stands for Nickel-Titanium Naval Ordnance Lab).
 - Contains 60 wt% Nickel and 40 wt% Titanium
 - 60NiTi is not a metal or a ceramic: a weakly ordered inter-metallic compound.
 - A close cousin to the shape memory alloy, NiTiNOL 55, but 60NiTi is dimensionally stable.
 - 60NiTi is bearing hard (Rockwell C60) but only half as stiff as steel.
 - Buehler found 60NiTi too difficult to manufacture but modern (ceramic) processing methods enable 60NiTi bearings with remarkable properties.

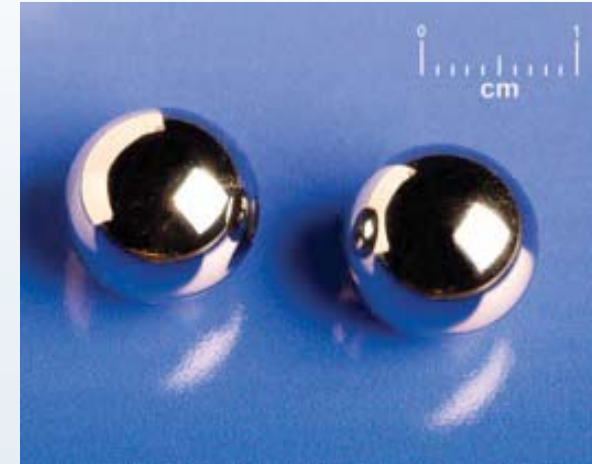

Highly polished 60NiTi bearing balls



60NiTi-Si₃N₄ Hybrid Bearing



Technical Properties Comparison:

Property	60NiTi	440C	Si ₃ N ₄	M-50
Density	6.7 g/cc	7.7 g/cc	3.2 g/cc	8.0 g/cc
Hardness	56 to 62 HRC	58 to 62 HRC	1300 to 1500 Hv	60 to 65 HRC
Thermal conductivity W/m-°K	~9 to 14	24	33	~36
Thermal expansion	~11.2×10 ⁻⁶ /°C	10×10 ⁻⁶ /°C	2.6×10 ⁻⁶ /°C	~11×10 ⁻⁶ /°C
Magnetic	Non	Magnetic	Non	Magnetic
Corrosion resistance	Excellent (Aqueous and acidic)	Marginal	Excellent	Poor
Tensile/(Flexural strength)	~1000(1500) MPa	1900 MPa	(600 to 1200) MPa	2500 MPa
Young's Modulus	~95 GPa	200 GPa	310 GPa	210 GPa
Poisson's ratio	~0.34	0.3	0.27	0.30
Fracture toughness	~20 MPa/√m	22 MPa/√m	5 to 7 MPa/√m	20 to 23 MPa/√m
Maximum use temp	~400 °C	~400 °C	~1100 °C	~400 °C
Electrical resistivity	~1.04×10 ⁻⁶ Ω-m	~0.60×10 ⁻⁶ Ω-m	Insulator	~0.18×10 ⁻⁶ Ω-m

- *Primary Points*

- *Modulus is ½ that of steel, yet hardness is comparable.*
- *Tensile strength akin to ceramics.*



Conventional Metals: Elastic Behavior

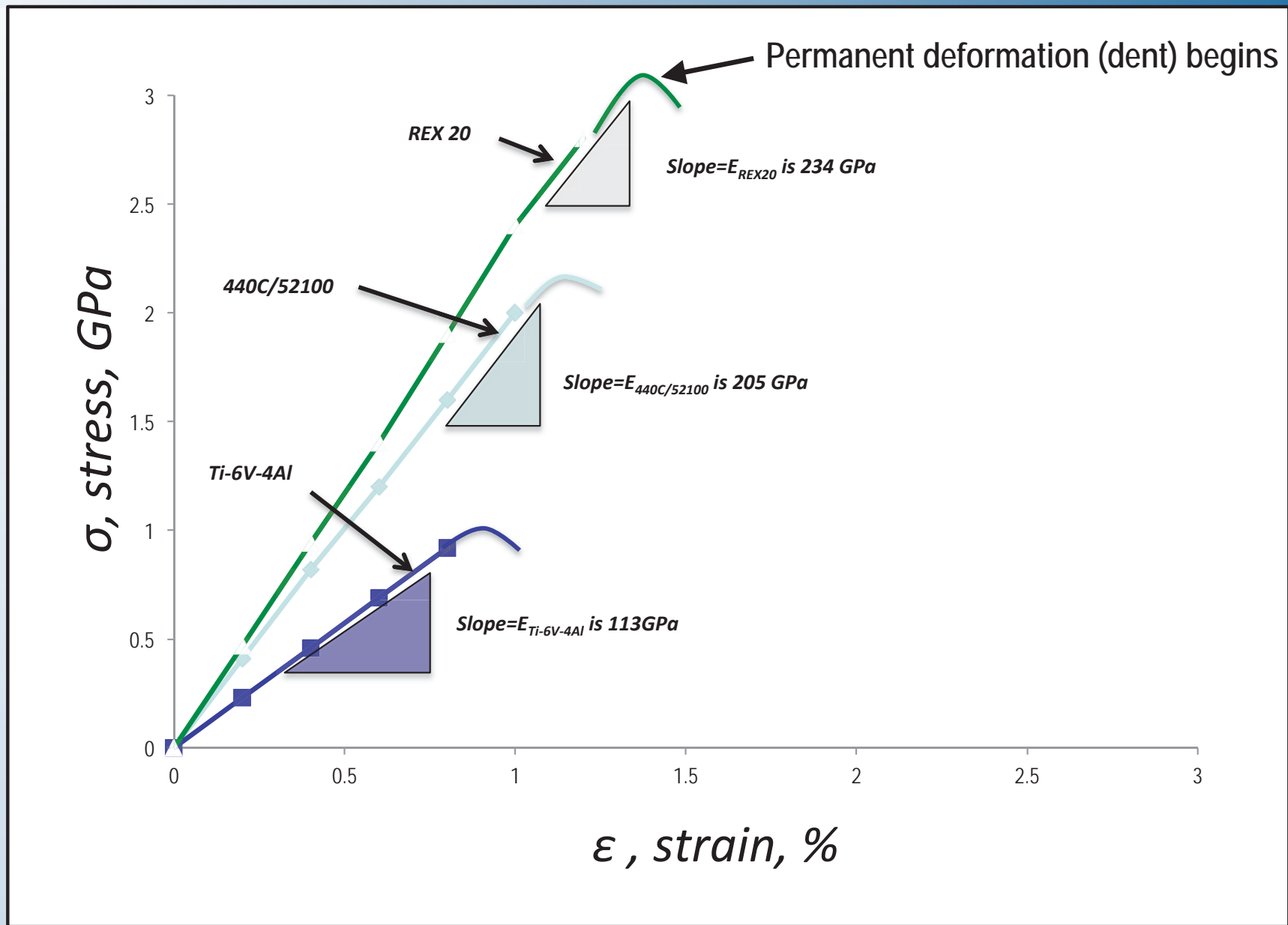



60NiTi: Stress-Strain Behavior

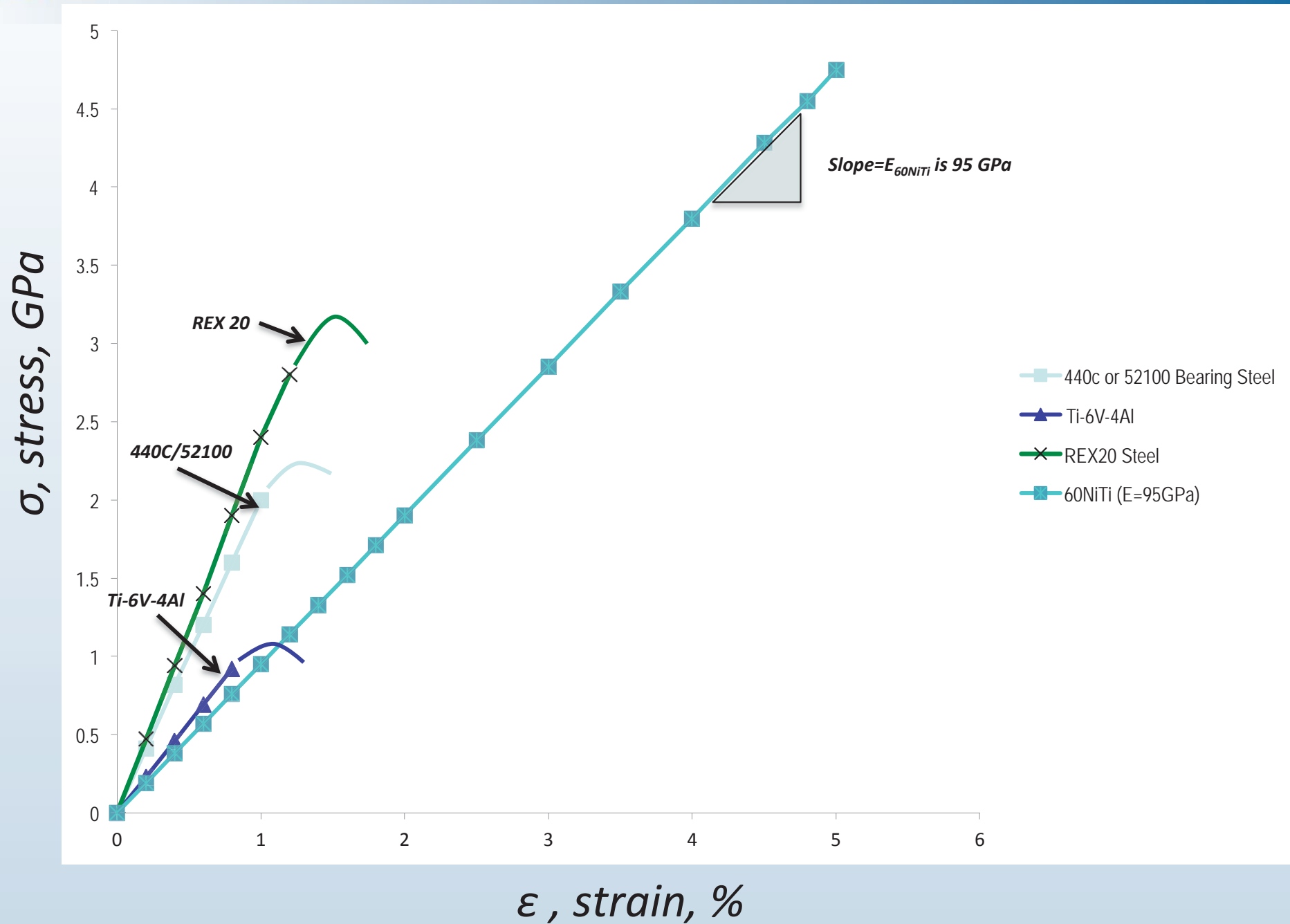



Brinell Test: Elucidates static load capacity

- How well does 60NiTi resist dents?
 - Brinell number
 - 12.7mm diameter Si_3N_4 ball
 - dp/D vs. stress (Leveille)

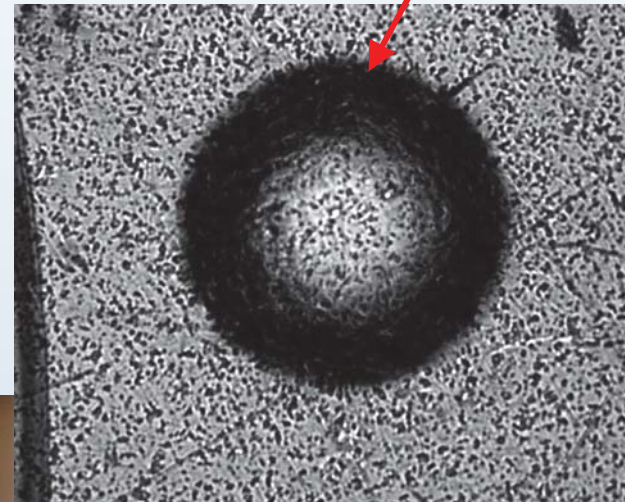
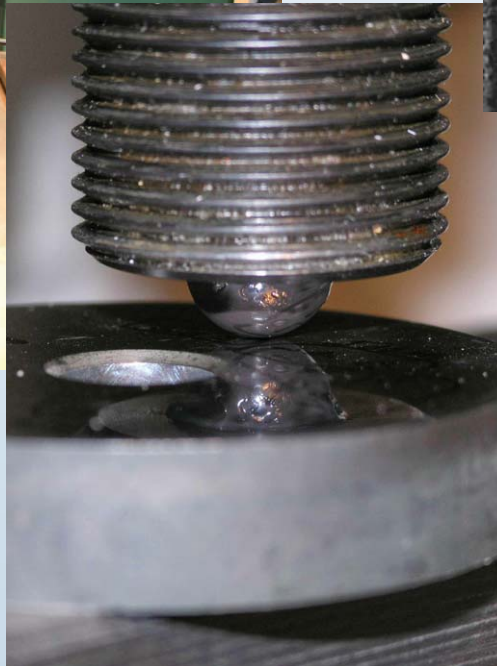

Deep Brinell dent.

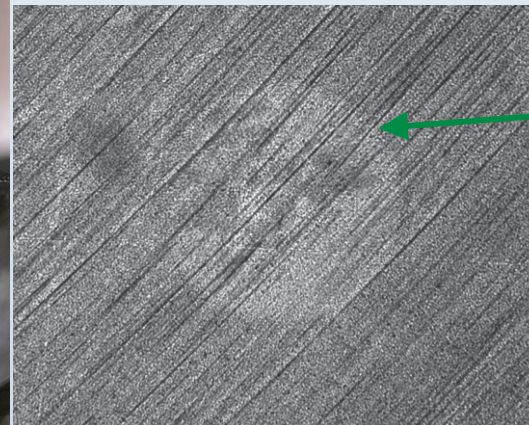

Threshold load visible dent.



Typical Result: 60NiTi-Superelastic

(Dent barely visible to unaided eye)

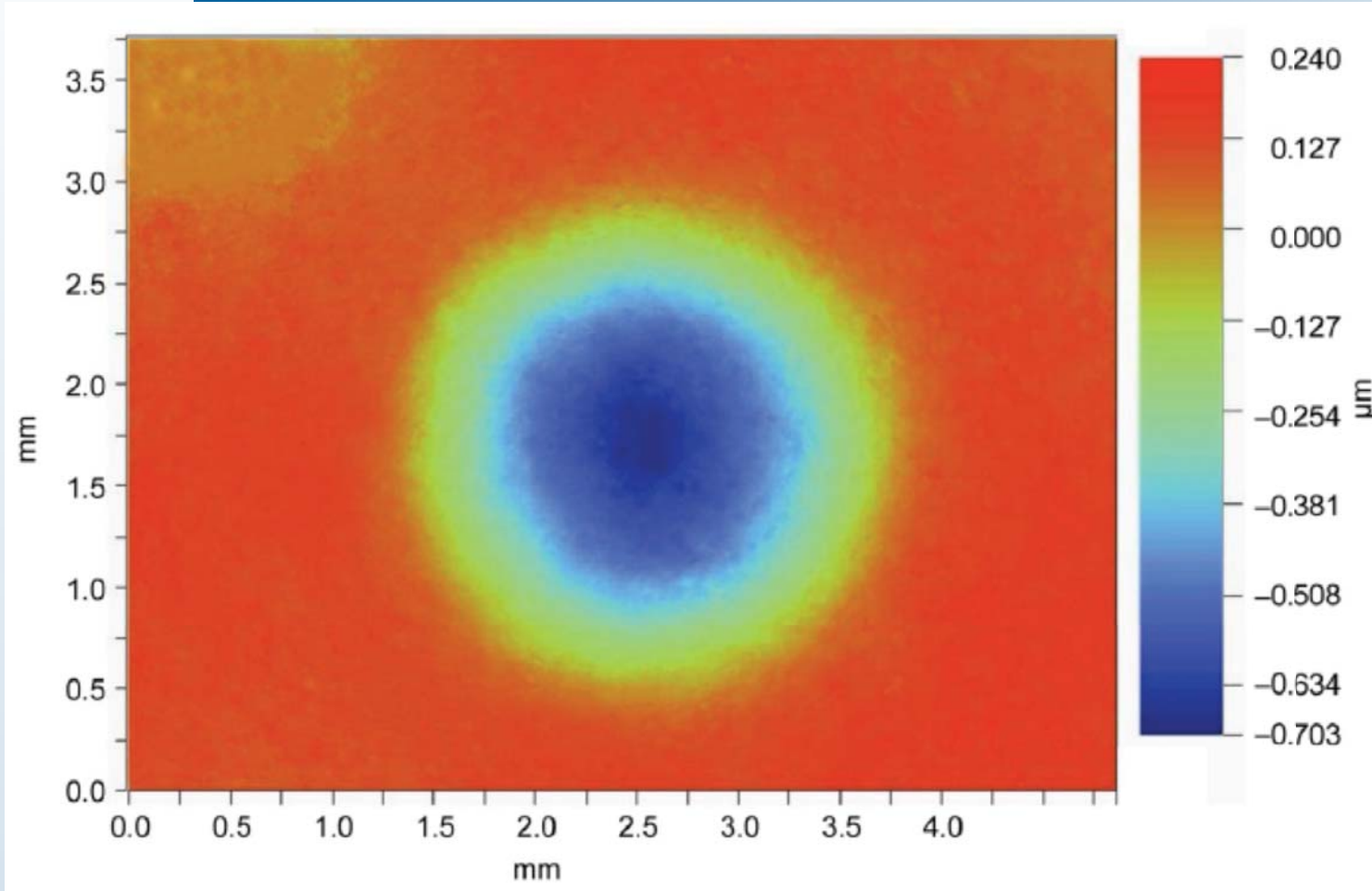

1500Kg (3300lb) load on 12.7mm diameter Si_3N_4 ball yields dent that is barely visible to the unaided eye but clearly defined by profilometry.



Dent Depth vs. Hertz Contact Stress

(12.7 mm diameter Si_3N_4 ball against 60NiTi plate)

dp, dent depth, μm

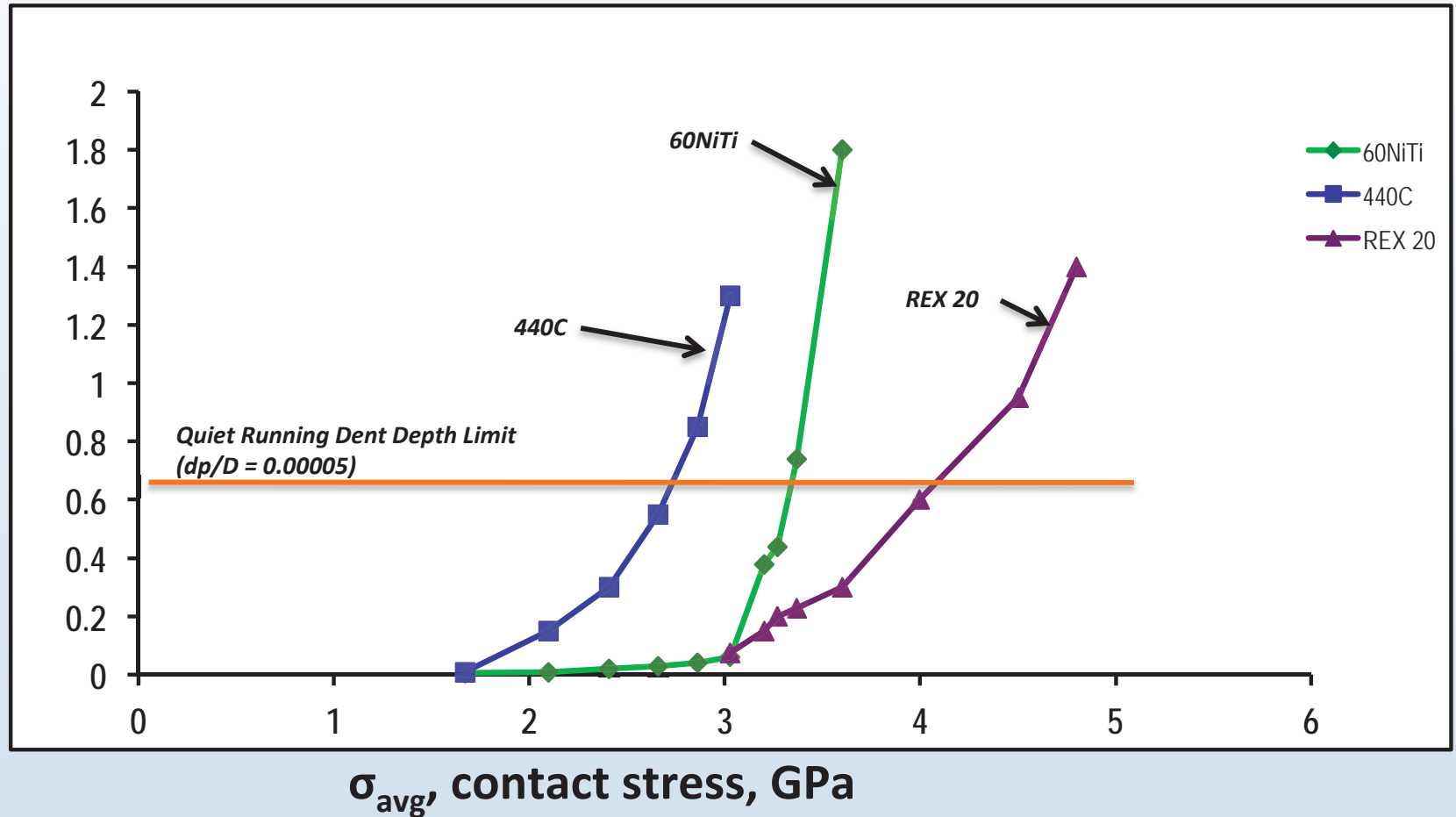



Dent Depth vs. Load

(12.7 mm diameter Si_3N_4 ball against 60NiTi plate)

dp, dent depth, μm

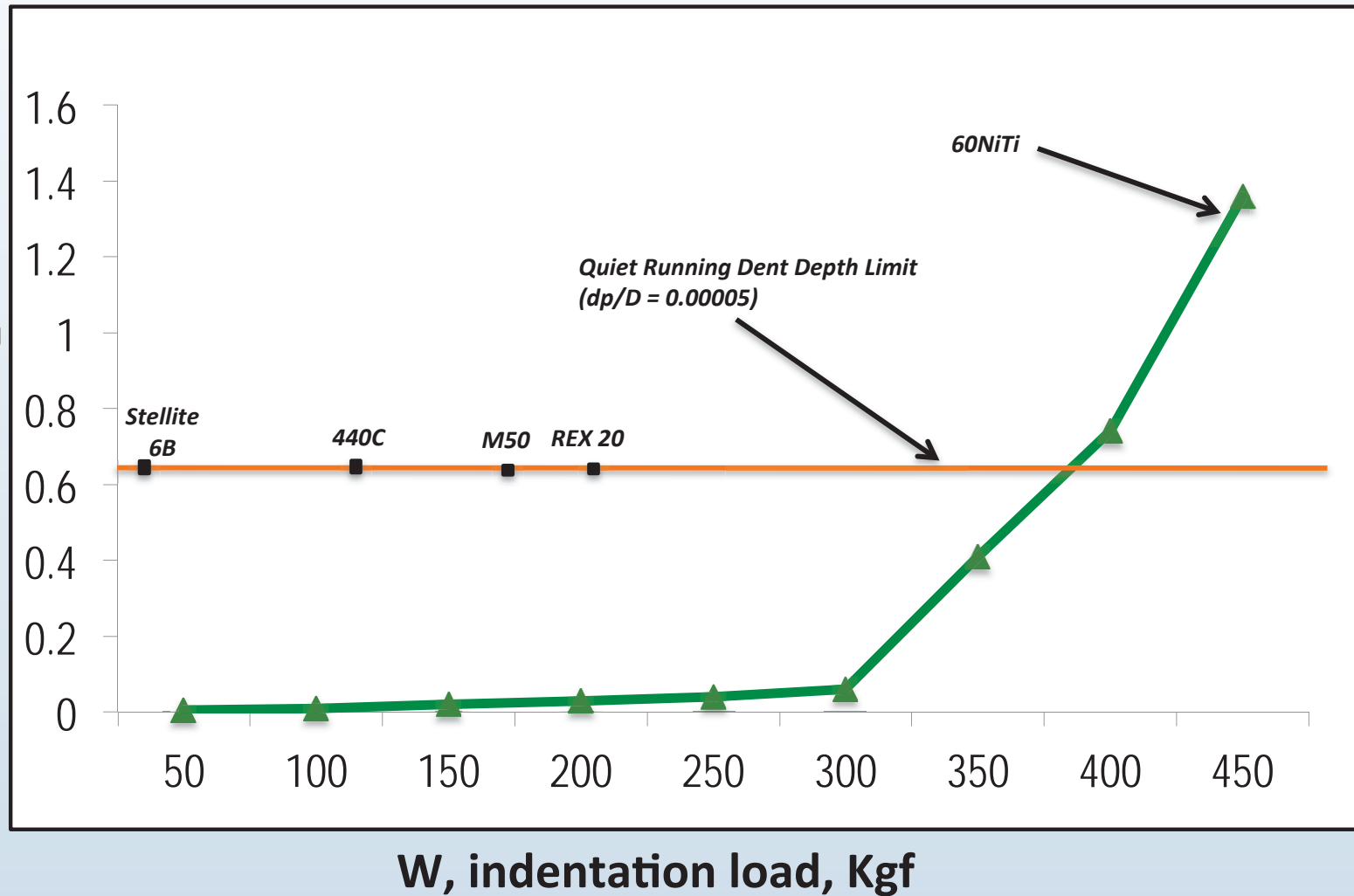



Damage Threshold Load Capacity: Comparison (12.7mm diameter ball pressed into plate)



Indent test

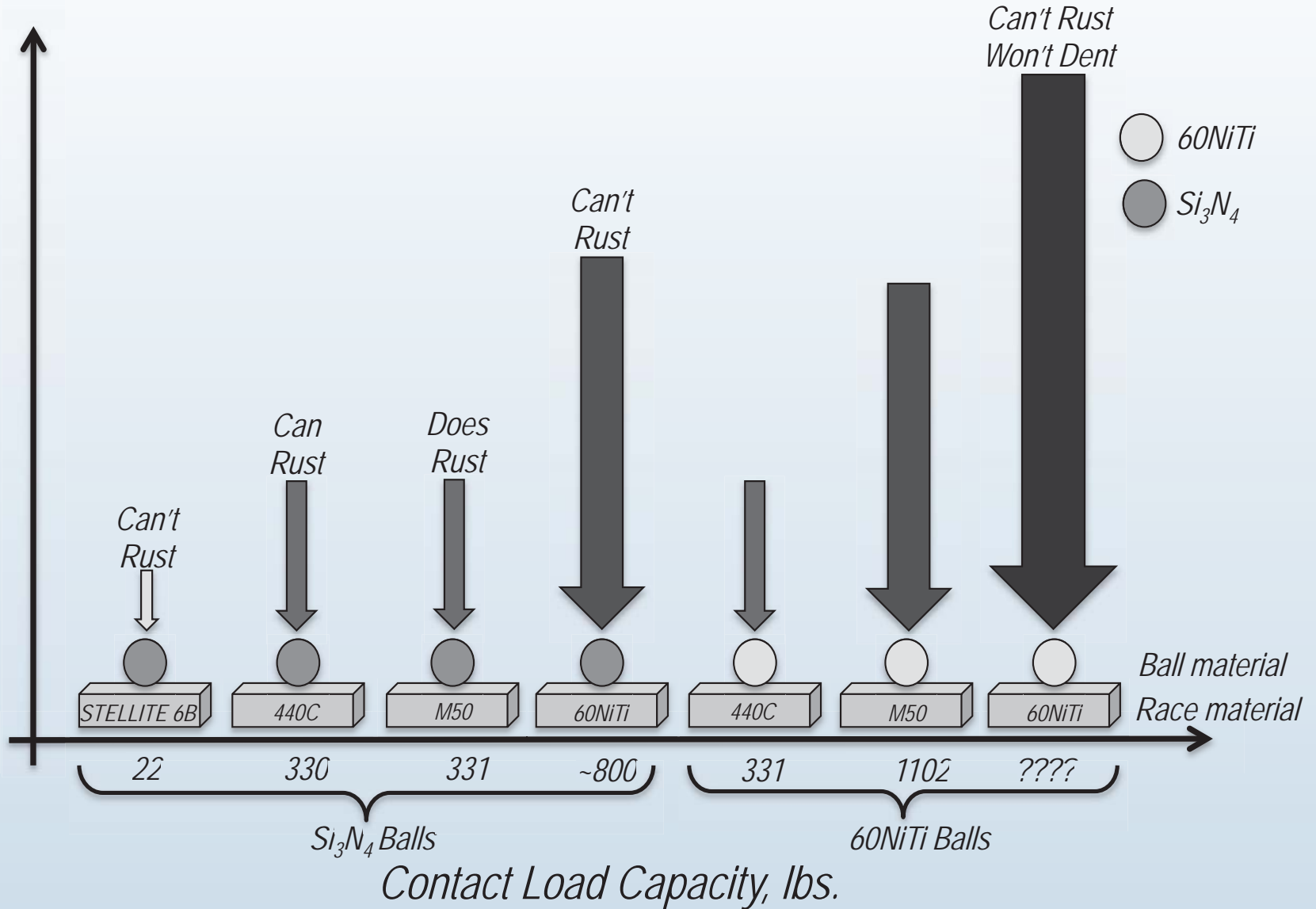

Low modulus + high hardness + superelasticity = extreme load capacity



Brinell Test: Effect of ball diameter?

- Do the dent limit results extend beyond a 12.7mm ball?
- Do the Hertz relations apply to superelastic materials?

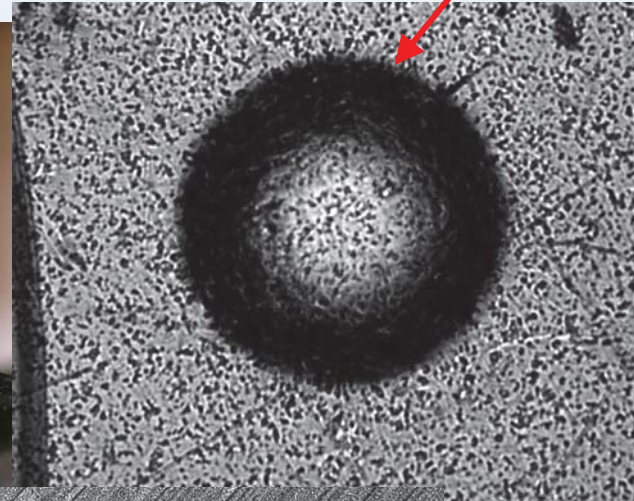
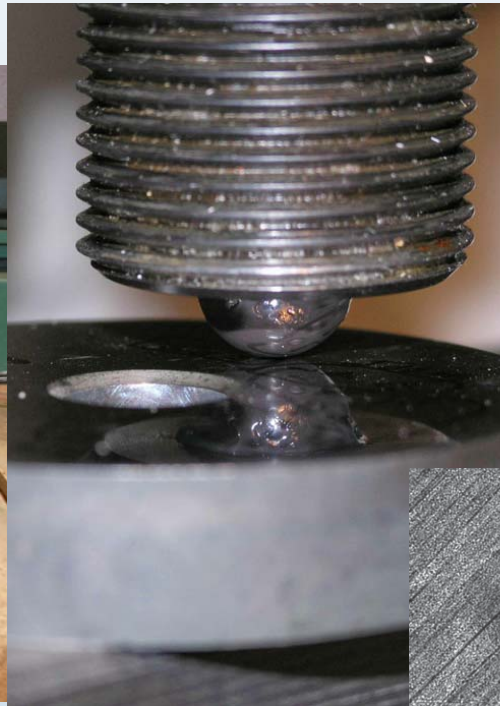

Deep Brinell dent.

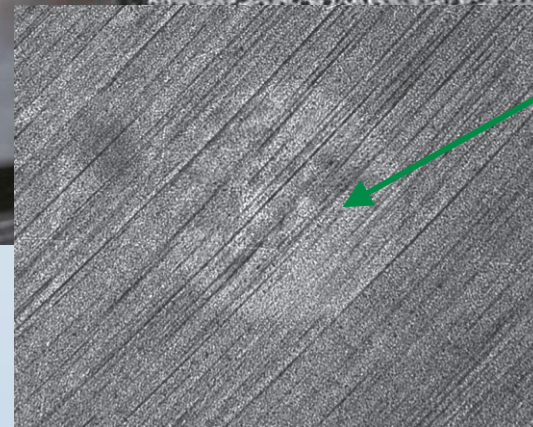

Threshold load visible dent.



Indent Plates: Cast 60NiTi-Superelastic (Heat treated to ~60 Rockwell C)

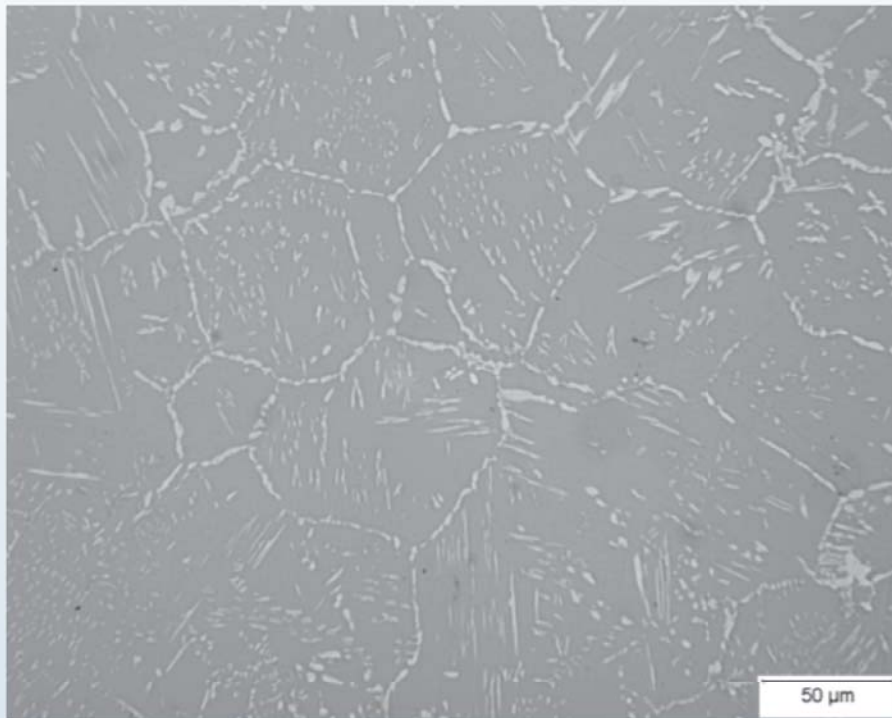

As-received 60NiTi (lighter phase is Ni₃Ti).

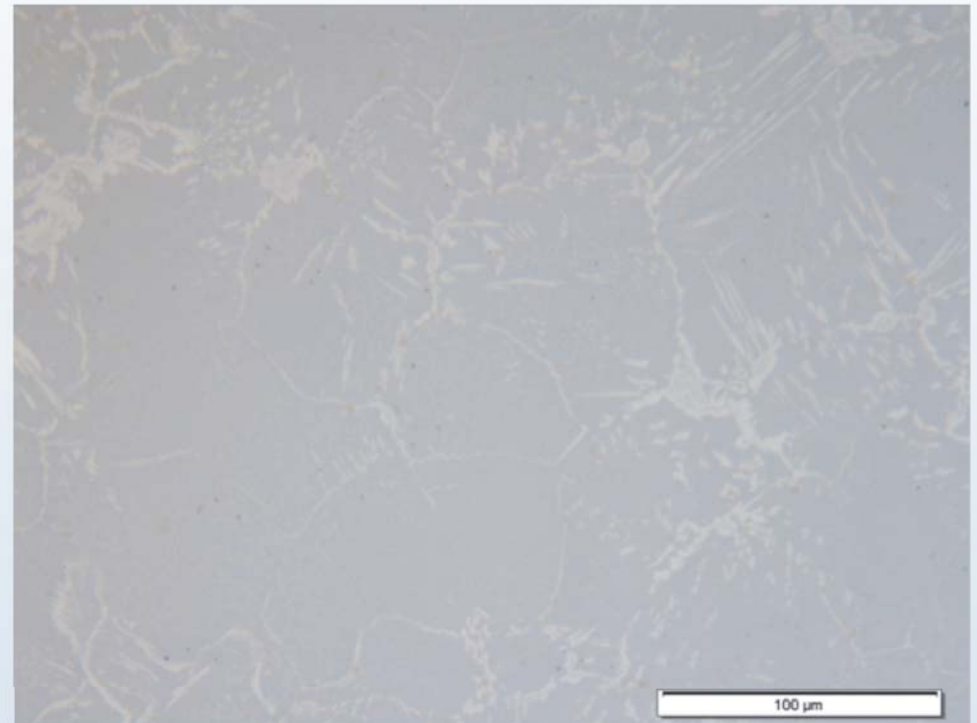

Heat-treated 60NiTi.

Clean and uniform microstructure yields highly polished, flat plate test specimens on which even small dents not readily visible can be measured.



Test Set-Up: Cast 60NiTi-Superelastic

(Provides repeat experiments)

Load Frame



Ball on disk set-up



Dent map-top view

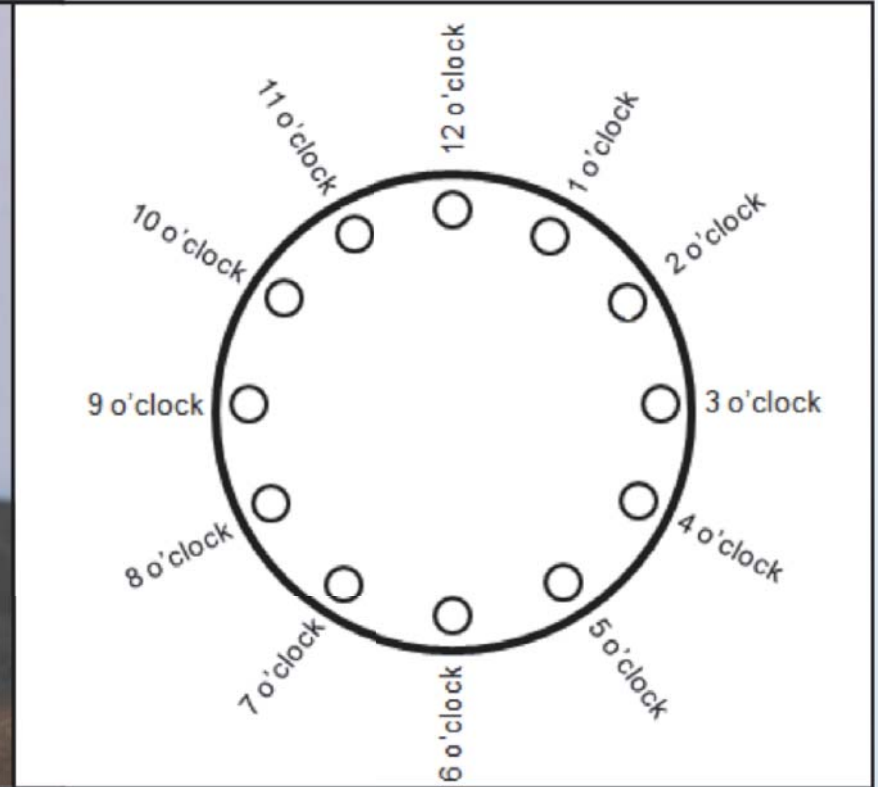

Carefully planned “dent” map and specimen numbering and fixture system allowed location of dents possible.



Tabular Results: 60NiTi-Superelastic (Si3N4 indenters from 6.35 to 12.7mm)

Load, Kg	6.35mm (1/4") ball			7.94mm (5/16") ball			9.52mm (3/8") ball			12.7mm (1/2") ball		
	Mean Stress, GPa	Dent Depth (dP), µm	dp/D x10 ⁻³	Mean Stress, GPa	Dent Depth (dP), µm	dp/D x10 ⁻³	Mean Stress, GPa	Dent Depth (dP), µm	dp/D x10 ⁻³	Mean Stress, GPa	Dent Depth (dP), µm	dp/D x10 ⁻³
50	2.65	0.11	0.017	2.3	0.06	0.008	2.0	~0	~0	----	----	----
100	3.35	0.56	0.088	2.9	0.19	0.024	2.6	0.15	0.016	----	----	----
150	3.83	1.50	0.236	3.3	0.59	0.074	2.9	0.18	0.019	----	----	----
200	4.20	2.30	0.365	3.6	1.0	0.126	3.2	0.57	0.06	2.7	0.20	0.016
250	4.54	3.60	0.564	3.9	1.7	0.214	3.5	1.0	0.105	2.9	0.36	0.028
300	4.83	5.30	0.84	4.15	3.0	0.378	3.7	1.6	0.17	3.0	0.56	0.044
350	----	----	----	----	----	----	----	----	----	3.2	0.66	0.052
400	----	----	----	----	----	----	----	----	----	3.4	0.83	0.065
450	----	----	----	----	----	----	----	----	----	3.5	1.36	0.107
500	----	----	----	----	----	----	----	----	----	3.6	1.68	0.132
550	----	----	----	----	----	----	----	----	----	3.7	1.99	0.157

Dent load ranges differed with indenter size to target stress range of interest (2.0-4.0GPa).



Effects of Indenter Diameter

Dent Depth vs. Stress: 6.4 to 12.7mm Si₃N₄ indenter balls

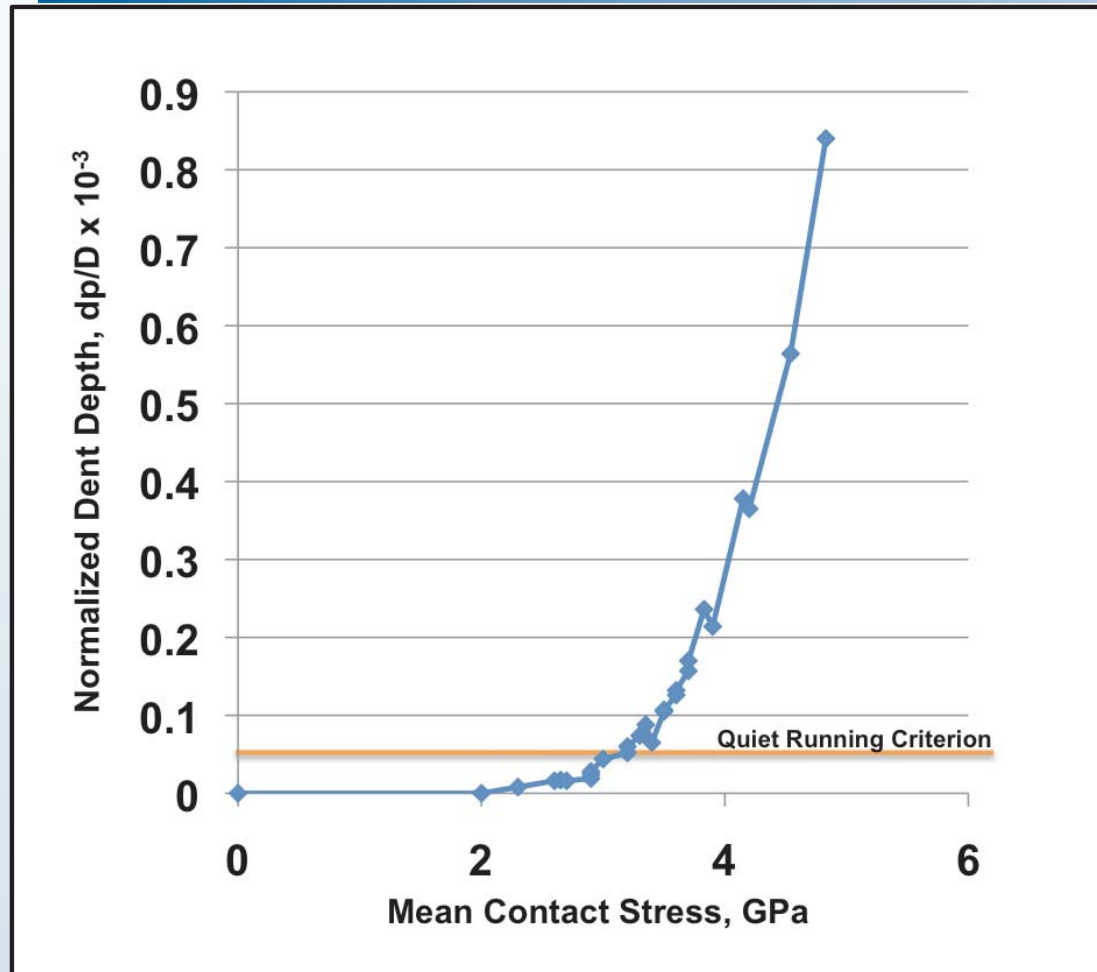

- *Implications*

- *Hertz stress relations work well for hard balls against flat plates.*
- *Data curve can be used to guide bearing detailed design.*



Status and Summary Remarks

- 60NiTi has been successfully fabricated into precision bearing balls and races.
- 60NiTi is hard yet has a low elastic modulus and large elastic deformation range enabling high static load capacity.
- Combination of aqueous corrosion immunity, non-magnetic and electrical conductivity not found in any other hard bearing material.
- Low modulus and high elasticity of superelastic gives it more load capacity than that inferred from hardness alone.
- Carefully planned and conducted denting experiments quantify stress-damage relationship.
- Results can be used to guide detailed bearing design.



Thank You!