

NASA/TM-2014-218553



Functional Analysis for an Integrated Capability of Arrival/Departure/Surface Management with Tactical Runway Management

Nipa Phojanamongkolkij
Langley Research Center, Hampton, Virginia

Nikolai Okuniek
German Aerospace Center, Braunschweig, Germany

Gary W. Lohr
Langley Research Center, Hampton, Virginia

Meilin Schaper
German Aerospace Center, Braunschweig, Germany

Lothar Christoffels
German Aerospace Center, Braunschweig, Germany

Kara A. Latorella
Langley Research Center, Hampton, Virginia

November 2014

NASA STI Program . . . in Profile

Since its founding, NASA has been dedicated to the advancement of aeronautics and space science. The NASA scientific and technical information (STI) program plays a key part in helping NASA maintain this important role.

The NASA STI program operates under the auspices of the Agency Chief Information Officer. It collects, organizes, provides for archiving, and disseminates NASA's STI. The NASA STI program provides access to the NASA Aeronautics and Space Database and its public interface, the NASA Technical Report Server, thus providing one of the largest collections of aeronautical and space science STI in the world. Results are published in both non-NASA channels and by NASA in the NASA STI Report Series, which includes the following report types:

- **TECHNICAL PUBLICATION.** Reports of completed research or a major significant phase of research that present the results of NASA Programs and include extensive data or theoretical analysis. Includes compilations of significant scientific and technical data and information deemed to be of continuing reference value. NASA counterpart of peer-reviewed formal professional papers, but having less stringent limitations on manuscript length and extent of graphic presentations.
- **TECHNICAL MEMORANDUM.** Scientific and technical findings that are preliminary or of specialized interest, e.g., quick release reports, working papers, and bibliographies that contain minimal annotation. Does not contain extensive analysis.
- **CONTRACTOR REPORT.** Scientific and technical findings by NASA-sponsored contractors and grantees.

- **CONFERENCE PUBLICATION.** Collected papers from scientific and technical conferences, symposia, seminars, or other meetings sponsored or co-sponsored by NASA.
- **SPECIAL PUBLICATION.** Scientific, technical, or historical information from NASA programs, projects, and missions, often concerned with subjects having substantial public interest.
- **TECHNICAL TRANSLATION.** English-language translations of foreign scientific and technical material pertinent to NASA's mission.

Specialized services also include organizing and publishing research results, distributing specialized research announcements and feeds, providing information desk and personal search support, and enabling data exchange services.

For more information about the NASA STI program, see the following:

- Access the NASA STI program home page at <http://www.sti.nasa.gov>
- E-mail your question to help@sti.nasa.gov
- Fax your question to the NASA STI Information Desk at 443-757-5803
- Phone the NASA STI Information Desk at 443-757-5802
- Write to:
STI Information Desk
NASA Center for AeroSpace Information
7115 Standard Drive
Hanover, MD 21076-1320

NASA/TM-2014-218553



Functional Analysis for an Integrated Capability of Arrival/Departure/Surface Management with Tactical Runway Management

*Nipa Phojanamongkolkij
Langley Research Center, Hampton, Virginia*

*Nikolai Okuniek
German Aerospace Center, Braunschweig, Germany*

*Gary W. Lohr
Langley Research Center, Hampton, Virginia*

*Meilin Schaper
German Aerospace Center, Braunschweig, Germany*

*Lothar Christoffels
German Aerospace Center, Braunschweig, Germany*

*Kara A. Latorella
Langley Research Center, Hampton, Virginia*

National Aeronautics and
Space Administration

Langley Research Center
Hampton, Virginia 23681-2199

November 2014

Available from:

NASA Center for AeroSpace Information
7115 Standard Drive
Hanover, MD 21076-1320
443-757-5802

Table of Contents

Abstract.....	3
1. Introduction	4
1.1. Purpose of Analysis.....	4
1.2. Document Organization.....	4
2. Air Traffic Management Environments: Germany and the United States.....	5
3. Tools and Capabilities	11
3.1. German Aerospace Center (DLR) Tools.....	11
3.2. National Aeronautics and Space Administration (NASA) Tools	12
4. Analysis of the Integrated System	13
4.1. Functional Analysis.....	13
4.2. Data Requirements	13
4.3. The Integrated System	16
4.3.1. Perform Tactical Runway Configuration Management (TRCM) Function (F.1)	20
4.3.2. Provide Advisory Airport Configurations Function (F.2)	25
4.3.3. Receive User Selection of Tactical Runway Configuration Management (TRCM) Configurations Function (F.3).....	26
4.3.4. Communicate Airport Configuration Change Function (F.4)	26
4.3.5. Perform Departure Management - Controller Assistance for Departure Optimization (CADEO) Function (F.5)	27
4.3.6. Perform Arrival Management – 4 Dimensional Cooperative Arrival Manager (4D-CARMA) Function (F.6).....	30
4.3.7. Perform Surface Management - Taxi Routing of Aircraft: Creation and Controlling (TRACC) Function (F.7)	33
4.3.8. Send Current Flight Information of Arrival/Departure/Surface Management (A/D/S-MAN) Function (F.8).....	37
5. Conclusions and Recommendations	37
Acronyms	40
References	41

Table of Figures

Figure 1: Preliminary functional overview of the Arrival/Departure/Surface Management and Tactical Runway Configuration Management integration..... 17

Figure 2: Preliminary N-squared chart for the Arrival/Departure/Surface Management and Tactical Runway Configuration Management integration..... 19

Figure 3: Perform Tactical Runway Configuration Management function (F.1)..... 20

Figure 4: Load Static Information function (F.1.1)..... 21

Figure 5: Receive dynamic information function (F.1.2)..... 22

Figure 6: Receive Tactical Runway Configuration Management parameters user preference function (F.1.3)..... 24

Figure 7: Evaluate runway configurations function (F.1.4)..... 25

Figure 8: Provide advisory airport configuration function (F.2)..... 26

Figure 9: Communicate airport configuration change function (F.4)..... 27

Figure 10: Perform Departure Management - Controller Assistance for Departure Optimization (CADEO) function (F.5)..... 27

Figure 11: Load static information function (F.5.1)..... 29

Figure 12: Receive dynamic information function (F.5.2)..... 29

Figure 13: Schedule departures function (F.5.3)..... 30

Figure 14: Perform Arrival Management – 4 Dimensional Cooperative Arrival Manager (4D-CARMA) function (F.6)..... 31

Figure 15: Load airspace function (F.6.1)..... 32

Figure 16: Receive dynamic information function (F.6.2)..... 32

Figure 17: Sequence arrivals function (F.6.3)..... 33

Figure 18: Perform Surface Management - Taxi Routing of Aircraft: Creation and Controlling (TRACC) function (F.7)..... 34

Figure 19: Receive dynamic information function (F.7.2)..... 35

Figure 20: Calculate surface trajectories function (F.7.3)..... 36

Figure 21: Send current flight information of Arrival/Departure/Surface Management function (F.8) ... 37

Table of Tables

Table 1: Air Traffic Environment 6

Table 2: Air Traffic Control Operations 7

Table 3: Data Category..... 14

Table 3: Data Category (continued)..... 15

Table 3: Data Category (continued)..... 16

Abstract

The runway is a critical resource of any air transport system. It is used for arrivals, departures, and for taxiing aircraft and is universally acknowledged as a constraining factor to capacity for both surface and airspace operations. It follows that investigation of the effective use of runways, both in terms of selection and assignment as well as the timing and sequencing of the traffic is paramount to the efficient traffic flows. Both the German Aerospace Center (DLR) and NASA have developed concepts and tools to improve atomic aspects of coordinated arrival/departure/surface management operations and runway configuration management.

In December 2012, NASA entered into a Collaborative Agreement with DLR. Four collaborative work areas were identified, one of which is called "Runway Management." As part of collaborative research in the "Runway Management" area, which is conducted with the DLR Institute of Flight Guidance, located in Braunschweig, the goal is to develop an integrated system comprised of the three DLR tools - arrival, departure, and surface management (collectively referred to as A/D/S-MAN) - and NASA's tactical runway configuration management (TRCM) tool.

To achieve this goal, it is critical to prepare a concept of operations (ConOps) detailing how the NASA runway management and DLR arrival, departure, and surface management tools will function together to the benefit of each. To assist with the preparation of the ConOps, the integrated NASA and DLR tools are assessed through a functional analysis method described in this report. The report first provides the high-level operational environments for air traffic management (ATM) in Germany and in the U.S., and the descriptions of the DLR's A/D/S-MAN and NASA's TRCM tools at the level of details necessary to compliment the purpose of the study. Functional analyses of each tool and a completed functional analysis of an integrated system design are presented next in the report.

Future efforts to fully develop the ConOps will include: developing scenarios to fully test environmental, procedural, and data availability assumptions; executing the analysis by a walk-through of the integrated system using these scenarios; defining the appropriate role of operators in terms of their monitoring requirements and decision authority; executing the analysis by a walk-through of the integrated system with operator involvement; characterizing the environmental, system data requirements, and operator role assumptions for the ConOps.

1. Introduction

The runway is a critical resource of any air transport system and is universally acknowledged as a constraining factor to capacity for both surface and airspace operations. It follows that investigation of the effective use of runways, both in terms of selection and assignment as well as the timing and sequencing of the traffic is paramount to the efficient traffic flows. Both the German Aerospace Center (DLR) and NASA have developed concepts and tools to improve atomic aspects of coordinated arrival/departure/surface management operations and runway configuration management.

Both NASA and DLR have extensively studied the efficient use of runways. For instance, DLR is conducting research on tactical decision support tools for air traffic control operators (ATCO) to achieve compact and coordinated arrival and departure sequences that also consider surface traffic. Arrival/Departure/Surface Management Systems individually plans every aircraft and displays its calculation results as advisories to the ATCO for implementation. In the area of runway management, NASA has focused on developing a decision support tool to assist air traffic personnel with decisions regarding the selection of runway configurations and runway usage. These decision support tools are intended for use by those making runway management decisions (usually supervisors or traffic flow managers) in the approach control facilities and the airport traffic control towers.

1.1. Purpose of Analysis

In December 2012, NASA entered into a Collaborative Agreement with DLR, located in Braunschweig, Germany. Four collaborative work areas were identified, one of which is called "Runway Management." As part of collaborative research in the "Runway Management" area, which is conducted with the DLR Institute of Flight Guidance, located in Braunschweig, the goal is to develop an integrated system comprised of the three DLR tools - arrival, departure, and surface management tools - and NASA runway management tool.

To achieve this goal, a tentative milestone (currently under review) for fiscal years (FY) 2015-2016 provides for the preparation of a concept of operations (ConOps) detailing how the NASA runway management tools and DLR arrival, departure, and surface management tools will function together to the benefit of each. To assist with the preparation of the ConOps, the integrated NASA and DLR tools are assessed through functional analysis method given in this document.

1.2. Document Organization

Section 0 compares the air traffic management (ATM) systems in Germany and in the U.S. in terms of facilities and general procedures, and for both operations in terminal airspace and on the surface. Following this comparison of the operational environments, a more detailed description of the individual tools is presented in section 3. Section 4 presents the integrated system using the functional analysis and Section 5 concludes the analysis. Recommendations are also given in this section.

2. Air Traffic Management Environments: Germany and the United States

The following section compares the operational contexts in Germany and the United States in which the respective tools were developed. A detailed description of the operational contexts can be found in ref. 1 (unpublished). Comparisons of procedures supporting each system are described. Table 1 compares air traffic environments in Germany and the United States, while Table 2 compares their air traffic control operations.

Traffic flow management is responsible for the overall flow of traffic in the respective airspace systems from a systemic perspective. Terminal airspace is normally composed of traffic transitional to (departures)/from (arrivals) enroute airspace. Terminal airspace as well as the airport surface are the relevant environments for the NASA and DLR integrated system. Effects of decisions made as a result of the integrated tools may affect enroute operations as well, albeit less directly. Note that system comparisons are limited to the level of detail necessary to compliment the purpose of the study.

Table 1: Air Traffic Environment

Enabling environment	German	U.S.
Air Traffic Control (ATC) system	The German air navigation service provider, “Deutsche Flugsicherung GmbH” (DFS), an institution of the German Federal Ministry of Transport and Digital Infrastructure (BMVI), is responsible for the operation of the air traffic control system as related to the integrated tools.	The Federal Aviation Administration (FAA), an agency of the Department of Transportation, is responsible for the operation of the air traffic control system.
Operational regulations	The manual of operational regulations for Air Traffic Control Services, called <i>Regulation of the Implementation of Air Traffic Control</i> (ref. 10) is the primary document for air traffic control, with additional regulations including national air traffic regulations, Letters of Agreement, ICAO publications, EUROCONTROL central flow management unit (CFMU) handbook, etc.	The air traffic control manual FAA JO 7110.65, “Air Traffic Control” (ref. 11) is the primary document governing the procedures for air traffic operations in the U.S.
Facilities	The Network Management Operations Center (NMOC), responsible for central traffic flow management in Europe, is part of EUROCONTROL.	Air Traffic Control System Command Center (ATCSCC), responsible for traffic flow management on a national scale.
	Area Control Centers (ACC), responsible for enroute traffic in the lower airspace (generally between ground level to any flight levels from 245 to 315).	Air Route Traffic Control Centers (ARTCC), primarily responsible for enroute traffic.
	There is no specific physical facility for approach control (ref.11a). Within the ACC facilities, there are controller working positions called Approach Control (APP), responsible for servicing all arriving and departing aircraft of a specific aerodrome ¹ .	Terminal Radar Approach Control (TRACON), responsible for air traffic services to aircraft departing airports and transitioning into the enroute environment and for arrival aircraft transitioning from the enroute environment to airports.
	Air Traffic Control Tower (TWR), responsible for air traffic services to aircraft in the immediate vicinity of the airport and on the airport surface.	Airport Traffic Control Towers (ATCT), responsible for air traffic services to aircraft on the airport surface (excluding ramp or non-movement areas).

¹ According to the International Civil Aviation Organization (ICAO), an aerodrome is “a defined area on land or water (including any buildings, installations and equipment) intended to be used either wholly or in part for the arrival, departure, and surface movement of aircraft.”

Table 2: Air Traffic Control Operations

ATC Operations	Germany	U.S.
Traffic flow management	Traffic flow management in Germany is called air traffic flow and capacity management (ATFCM) and is administered by the DFS and the NMOC (former CFMU) of EUROCONTROL. The objectives of ATFCM are adjusting demand and capacity on the basis of strategic planning.	Traffic flow management is a process managed through the ATCSCC and a network of traffic management units throughout the U.S. The basic objective of traffic management is to provide for an efficient flow of traffic throughout the National Airspace System (NAS) which is manageable for air traffic controllers.
Terminal area airspace	Terminal area airspace varies significantly based on local constraints that are nearby cities, mountains and legal issues regarding noise and emissions. The dimensions are typically 16-27 nautical miles from the primary airport (ref. 13). Departures and arrivals are normally guided on predefined departure and arrival routes dependent on the aircraft equipment (ref. 14). Arrival and departure “fixes” are designated waypoints on the standard terminal arrival route (STAR) and the standard instrument departure (SID), respectively. Arrival fix denotes a metering fix, called the <i>clearance limit</i> of the STAR. Dependent on the airport, the <i>clearance limit</i> can lie inside or outside of the terminal area of the airport. Departure fix denotes the last waypoint of the SID.	Terminal area airspace varies significantly based on local constraints. Several high density facilities have adopted a common design which lends itself to the use of common procedures. This design is commonly referred to as a “four-corner post system” which defines the arrival routes from the northeast, southeast, southwest, and northwest into the terminal airspace. Departure “gates” are located between the arrival corridors in the north, east, south, and west areas of the airspace. Arrival and departure “fixes” are normally located at the terminal boundary, agreed to by the TRACON and adjacent facility, usually an ARTCC. The dimensions are typically 35-40 nautical miles from the primary airport.

ATC Operations	Germany	U.S.
Terminal airspace operations for arrivals	<p>The aircraft navigate via a STAR route to the Initial Approach Fix (IAF). Generally, aircrafts are expected to fly according to area navigation (RNAV) transition procedure, which is published in German aeronautical information publication (AIP). RNAV usually begins at the clearance limit (arrival fix) and leads the aircraft on the downwind segment to the final approach fix (FAF), usually 11–12 nautical miles away from the runway threshold.</p> <p>Information on active runways is available through the Automatic Terminal Information Service (ATIS), and is updated every 30 minutes. Because runway assignment depends on aircraft wake class and on the flight direction, the flight-to-runway assignment is implicitly derived from the latest runway information from the ATIS. Before flight crews enter the terminal area, they have to listen to ATIS for the runway information. The APP controller also confirms which runway to use. The aircraft usually is handed over to the ATCT when or before passing the FAF.</p>	<p>Generally speaking, arrivals flow from Center airspace into terminal airspace on routings defined by standard terminal arrival routes (STARs). Upon entry to the terminal area flight crews will be given a runway assignment. At the terminal point of the STAR, controllers will provide headings for the transition to the final approach course. Aircraft will be sequenced with other traffic in the terminal area and the appropriate spacing's/separation standards applied. The ATCT assumes responsibility of aircraft once they pass the FAF; in the U.S., the FAF is usually five nautical miles from the runway. In the event of a runway configuration change, a determination is made as to which aircraft will be the last to land on the current configuration, and the first aircraft for each arrival runway of the new configuration.</p>
Terminal airspace operations for departures	<p>Primarily aircraft are assigned to runways depending on their initial flight direction. Because of noise abatement procedures, aircraft always navigate via predefined standard instrument departure (SID) or via an assigned departure procedure.</p>	<p>Departure aircraft are assigned runways based on initial direction of flight. To optimize spacing, aircraft are sequenced such that there are divergent headings (normally a minimum of 15 degrees) immediately after departure between successive departures. Departures will either be navigating via SIDs, or based on headings assigned by the controller.</p>

ATC Operations	Germany	U.S.
Airport surface area	<p>The airport surface is segmented into the maneuvering area and the apron. While the maneuvering area is controlled by ATC, the apron area is controlled either by the airport or ATC. The border for the handover between both areas is marked in the aerodrome charts published in the AIP of every airport. There are no marks on the taxiways, so there is no interruption in the taxi phase on the airport surface either from touchdown to engines off, and vice versa.</p>	<p>The airport surface is divided into movement and non-movement areas. It is quite common that the airlines lease gates and hence have control over all activity in the ramp area. The border between these responsibilities is marked by “spots” at many high density airports. Every departure aircraft is cleared to proceed to a spot by the airline ramp controller. There, ATC specifically the ground controller, assumes responsibility for the aircraft and assigns a departure runway.</p>
Airport surface operations for arrivals	<p>Arriving aircraft are handed over from the “local controller” of TWR to the “ground controller” of TWR shortly after touchdown. While leaving the runway, the ground controller assigns a taxi route and confirms the gate. If control of the apron area is conducted by the airport operator, the ground controller hands over to apron control before the aircraft enters the apron area.</p>	<p>Arrival aircraft are assigned an arrival runway which is usually closest to the arrival fix they have crossed upon entering the terminal area. The ATCT assumes responsibility of aircraft once they pass the FAF. The “local controller” issues a landing clearance; upon exiting the runway, the flight crew contacts the “ground controller” who issues clearance to the ramp or non-movement area, with necessary restrictions incorporated. Once arrival aircraft enter the ramp area, the “ramp controller” assumes their responsibilities.</p>

ATC Operations	Germany	U.S.
<p style="text-align: center;">Airport surface operations for departures</p>	<p>Departing aircraft get their enroute and start-up clearance (via voice or datalink communications) by clearance delivery in the ATCT, and pushback clearance from apron controller. When ready for taxi, apron controller assigns a taxi route in its area of responsibility. Before the aircraft pass the border of responsibility, the apron controller hands the aircraft over to the ground controller. Before the aircraft arrive at the departure runway, the ground controller instructs the aircraft to switch to the local controller who gives the line-up and take-off clearance.</p>	<p>Aircraft movements are generally under the control of a “ramp controller” who is responsible for aircraft in the ramp area. While in this area, flight crews will obtain the Automatic Terminal Information Service information as well as their pre-departure clearance from the tower clearance delivery position. At many high density facilities, there are “spots” where departing aircraft wait for ATC to provide clearance into the movement area. Ground controller will provide clearance for aircraft to taxi to their departure runway. Departures are often subject to delays based on either constraints at the departure airport, or delays imposed based on considerations in the enroute environment or at the destination airport. The local controller will issue take-off clearance followed by a frequency change to the departure controller (located in the TRACON) shortly after the aircraft is airborne.</p>

The basic objectives of the air traffic control systems in Germany and the United States are the same, i.e. to provide for the safe and efficient movement of aircraft. Although fundamentally the same, there are differences in procedures, airspace structure, roles/responsibilities, among others as described in this section. In Germany the general problem is the dense airspace caused by overflights of European air traffic and the small airport surface. With the consideration of noise abatement and the avoidance of storm cells, the rising traffic demand needs to be handled in the same airspace area. DLR is investigating how the present traffic demand can fully use the allocated capacity. In the U.S., the problem is the large number of aircraft and in many cases, limited surface area; there are, of course, many other aspects of the air traffic flow process and supporting elements that affect capacity and efficiency. There are on-going research efforts to address many facets of the airspace system in Germany and the U.S.

3. Tools and Capabilities

3.1. German Aerospace Center (DLR) Tools

There are three well known concepts in Europe to handle arrival, departure, and surface traffic. These concepts are Arrival Management (AMAN), Departure Management (DMAN), and Surface Management (SMAN).

Reference 2 defines AMAN as “a general term given to the process of safely and effectively arranging arrivals into a smooth efficient flow for landing at a destination airport. Although no agreed definition is in place, when people consider or talk about dedicated Arrival Management software, they are usually considering this type of software specifically designed to provide assistance in metering and sequencing arrival streams of traffic and which gives, via electronic display, all the time management, and other information needed to implement efficient arrival management.”

Reference 3 defines DMAN as “a planning system to improve departure flows at an airport by calculating the target take-off time (TTOT) and target start-up approval time (TSAT) for each flight, taking multiple constraints and preferences into account.”

Reference 4 defines SMAN as “a tool within Advanced Surface Movement Guidance and Control System (A-SMGCS²) that will determine the optimal surface movement plans involving the calculation and sequencing of movement events and optimizing resource usage, while minimizing the environmental impact.”

Based on these concepts, DLR developed research prototypes for decision support tools called 4 Dimensional Cooperative Arrival Manager (4D-CARMA), Controller Assistance for Departure Optimization

² A-SMGCS is “a system providing routing, guidance and surveillance for the control of aircraft and vehicles in order to maintain the declared surface movement rate under all weather conditions within the aerodrome visibility operational level (AVOL) while maintaining the required level of safety.” (skybrary, http://www.skybrary.aero/index.php/Advanced_Surface_Movement_Guidance_and_Control_System_%28A-SMGCS%29 [last access: 2014-10-29]).

(CADEO), and Taxi Routing of Aircraft: Creation and Controlling (TRACC) for AMAN, DMAN, and SMAN, respectively.

4D-CARMA is the DLR arrival management system that builds an arrival sequence, assigns an arrival time at the threshold, continuously adapts to the actual situation, predicts trajectories for all aircraft, and transforms them into appropriate guidance instructions for the air traffic controller (ref. 5). For any arrivals, 4D-CARMA's planning responsibility begins when an aircraft enters the terminal maneuvering area, and ends when the aircraft touches down. The corresponding working positions are approach controller in the ACC (refer to table 1 for ACC definition).

CADEO is the DLR departure management system that optimizes the departure sequence at the runways while considering arrivals on the same runway or a dependent runway. It provides the calculations of TTOT and TSAT to Airport Collaborative Decision Making System (A-CDM)³. Departure queues at the runway are mostly avoided and the environmental stress is minimized (ref. 6). For any departures, CADEO's planning responsibility begins approximately 20 minutes before an aircraft's target off-block time (TOBT⁴), and ends when the aircraft takes off. The corresponding working positions are local, ground controller, and also clearance delivery controller in the TWR (refer to table 1 for TWR definition).

TRACC is the DLR surface management system that generates conflict-free taxi routes from gate to runway and vice versa to meet TTOTs with a minimum of speed changes during the taxi process. Furthermore, it provides guidance instructions (speed and route) for the air traffic controller (ref. 7). For any arrivals, TRACC's planning responsibility begins approximately five minutes before an aircraft's target landing time (TLDT) and ends when the aircraft arrives at the gate. For any departures, TRACC's planning responsibility begins approximately five minutes before an aircraft's TOBT and ends when the aircraft lines up for departure. The corresponding working positions are ground controller and apron controller either seated in the air traffic control tower or a dedicated control facility.

3.2. National Aeronautics and Space Administration (NASA) Tools

System-Oriented Runway Management (SORM) consists of Runway Configuration Management (RCM) and Combined Arrival Departure Runway Scheduling (CADRS). RCM is subdivided into two different time horizons with different capabilities for different stakeholder (refs. 8, 9). RCM consists of a strategic and a tactical element. Research in the area of strategic runway configuration management is focused on balancing traffic demand and capacity in the NAS over a time horizon of six hours to support traffic flow management. TRCM calculates airport configurations and the configuration change time between these configurations over a time horizon of 90 minutes.

³ European A-CDM was based on the U.S. concept of Collaborative Decision Making to improve airport's decision making by sharing accurate and timely information (skybrary, http://www.skybrary.aero/index.php/Main_Page [last access: 2014-10-29]).

⁴ Target off-block time (TOBT) is the time that an aircraft operator or ground handler estimates that an aircraft will be ready, all doors closed, boarding bridge removed, push-back vehicle available, and ready to start up / push back immediately upon reception of clearance from the airport traffic control tower.

Only the tactical runway configuration element of SORM will be used in this collaboration. TRCM provides runway configuration and runway usage recommendations intended for use by traffic flow managers and supervisors. The TRCM capability primarily considers overall transit time and delay for arrivals and departures. For arrivals, calculations for transit from arrival fix (normally at the terminal boundary (entry point to TRACON airspace) to the ramp area. For departures, it is the time from the ramp area to the departure fix, also at the terminal boundary. The 90 minute planning horizon used is based on the tactical nature of runway changes. After a configuration change is made, no additional configuration changes will be recommended by the algorithm for a 30 minute period⁵. The current version of TRCM primarily considers traffic demand and weather information. The longer-term vision incorporates airport operator constraints, system user preferences, and traffic flow considerations. TRCM is intended for use by those making runway management decisions (usually supervisors or traffic flow managers) in the approach and departure control facility and the airport traffic control towers.

4. Analysis of the Integrated System

In this section, the manner in which the aforementioned tools are combined to form the proposed integrated system is analyzed using functional analysis. Section 4.1 describes functional analysis. Data requirements for all tools are defined in section 4.2. Section 4.3 presents the integrated system.

4.1. Functional Analysis

Functional Analysis is a study of process activities that arranges functions in logical sequences, decomposes higher-level functions into lower-level functions, and identifies all internal and external functional interfaces. The tools used to model the functional behavior of a system are functional flow block diagram (FFBD) and N-squared (N2) diagramming techniques. The FFBD technique details the logical and environmental sequence of the system, while the N2 diagramming technique provides the data environment of the system. Both the FFBD and N2 diagrams provide complementary functional behavior of the system.

4.2. Data Requirements

Table 3 defines all necessary data requirements for all tools along with their associated potential data sources. Data are categorized into seven groups, each with different colors:

- Airport adaptation
- Flight information
- TRCM optimization parameters
- BADA⁶ aircraft database
- TRCM output
- TRCM user selection
- Environmental data

⁵ The 30-minute period may be dependent on airport environment, and is a subject for further investigation.

⁶ Base of Aircraft Data (BADA) is a database containing performance and operating procedure coefficients for different aircraft types. The coefficients include those used to calculate thrust, drag and fuel flow and those used to specify nominal cruise, climb and descent speeds.

For every mentioned data category, the respective information that corresponds to the category and the allocation to the decision support tool are listed in Table 3. The “X” indicates which tool uses the respective data either as input or output. An “(X)” indicates that this information is important but used indirectly, and “F” indicates future work that has to be done.

Table 3: Data Category

	Data Description	TRCM	CADEO	4D-CARMA	TRACC
Airport Adaptation	Airlines	X			
	Airline-to-Gate Assignment	X			
	Configurations	X	(X)	X	(X)
	Departure Runway SID Separations	X	X		
	Departure Runway Speed Separations	X	X		
	Departure Runway Wake Vortex Separations	X	X		
	Fixes	X			
	Gates	X			
	Gate-to-Spot Assignment	X			
	Path Stretching Procedures			X	
	Routes from Arrival Fix to Threshold			X	
	Runway Policies	X			
	Runways	X	X	X	X
	Runway-to-STAR Assignment			X	
	SIDs		X		
	Spots	X			
	Spot-to-Taxiway Assignment	X			
	STARs			X	
	Taxiways (Node-link)	X			X
	Transition Routes			X	
	Variable Taxi Time (VTT)	X	X		
	Waypoints with Constraints			X	
	Airspace Operational Status (VMC or IMC)	X			
	Arrival Runway Wake Vortex Separations	X		X	
	Airport Resource Constraints (e.g., Runway Closure)	X			
Controller Working Positions			X	F	
Standard Taxi Routes				X	

Table 3: Data Category (continued)

	Data Description	TRCM	CADEO	4D-CARMA	TRACC
Flight Information	Flight Information - Assigned Fix	X			
	Flight Information - Assigned Runway	X	X	X	X
	Flight Information - Assigned Spot/Gate/Stand	X	X		X
	Flight Information - Call Sign	X	X	X	X
	Flight Information - Calculated Take-Off Time (CTOT)		X		
	Flight Information - Flight Plan	X	X	X	X
	Flight Information - Target Landing time (TLDT)	X	X	X	X
	Flight Information - Service Type	X	X		X
	Flight Information - Unimpeded Spot/Gate Time	X			
	Flight Information - Target Off-Block Time (TOBT)	X	X		F
	Flight Information - Estimated Landing Time (ELDT)	X	X		X
	Flight Information - Unimpeded Time at Runway for Arrivals or Unimpeded Landing Time	X			
	Flight Information - Unimpeded Time at Runway for Departures	X			
	Flight Information - Target Start-Up Approval Time (TSAT)	X	X		F
	Flight Information - Target Take-Off Time (TTOT)	X	X		
	Flight Information - Position Data from Radar Data			X	
	Flight Information - Position Data from A-SMGCS		X		X
	Flight Information - Clearance Inputs from Controller		X		X
	Flight Information - Earliest Take-Off time (ETT)		X		

Table 3: Data Category (continued)

	Data Description	TRCM	CADEO	4D-CARMA	TRACC
TRCM Parameter	Current (Active) Configuration	X			
	Alternative Configurations	X			
	TRCM Planning Horizons	X			
	TRCM Freeze Horizon	X			
	TRCM Minimum Time between Configuration Change	X			
	TRCM Alternative Runway Policies	X			
	TRCM Objective Function Metric	X			
TRCM Output	Baseline Configuration	X			
	Baseline Objective Function Metrics	X			
	Baseline Flight List (Flight-Runway Assignment)	X			
	Optimal Configuration	X		X	
	Optimal Objective Function Metrics	X			
	Optimal Flight List (Flight-Runway Assignment; the last flight on the active configuration, and the first flight on the new configuration)	X	X		X
	Optimal Configuration Changetime	X		X	
TRCM User Selection	User Selection on Configuration (Change or NoChange)	X			
BADA	Aircraft Taxi Speed	X			
	Aircraft Take-Off or Landing Speed	X		X	
	Aircraft Weight Class	X		X	
	Rate of Climb and Descent / True Airspeed			X	
	Diverse calculation coefficients for Thrust and Drag			X	
Environmental Data	Wind Velocity	X			
	Ceiling and Visibility	X			
	Noise Constraints	X			

4.3. The Integrated System

Because available data sources and data necessary for DLR and NASA tools generally differ, the analysis of the integrated system presented here will be at the higher level of details, where the FFBD is applicable to both the German and the U.S. air traffic environments. The lower FFBD levels vary depending upon to where the integrated system is tailored, (i.e., the German or the U.S. airports.) Reference 1 (unpublished) provides all lower FFBD levels tailored for a German airport, given all data sources needed for all tools are available at the centralized A-CDM of the German airport.

Figure 1 shows the highest level FFBD of the AMAN, DMAN, SMAN (collectively referred to as A/D/S-MAN) and TRCM integration and, therefore, provides an excellent way to overview of the integration. The

underlined function names in the FFBD indicate that the function can be decomposed into lower-level functions.

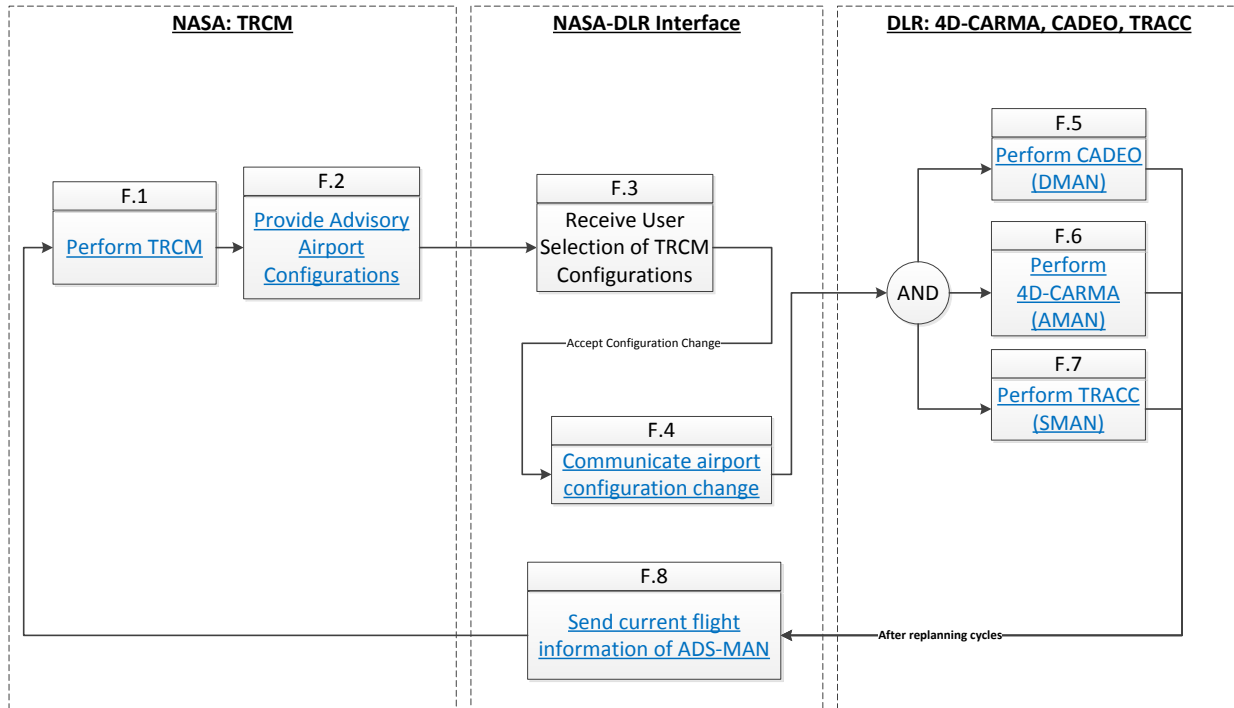

Figure 1: Preliminary functional overview of the Arrival/Departure/Surface Management and Tactical Runway Configuration Management integration.

At the high level, there are three main systems for the integrated system: TRCM (functions 1 and 2), the interface (functions 3, 4, and 8), and A/D/S-MAN (functions 5, 6, and 7).

TRCM evaluates the current and the optimal runway configurations (F.1) and repeats the evaluation process at a predetermined time-based planning frequency. At this predetermined re-planning time, TRCM takes snapshots of the current air traffic system as input to its optimization algorithm. TRCM then provides advisory (both the current active and the optimal) configurations along with its performance metrics to the air traffic personnel (supervisors or traffic flow managers) (F.2). The controller can choose to accept or reject the recommended configuration (F.3). The rejection of the recommended configuration implies no change to the current active configuration, and TRCM will wait until the next planning cycle to repeat the evaluation process. If the recommended configuration is selected, the airport configuration is updated (F.4) and will be used in planning by A/D/S-MAN in the next functions. Function 4 represents this interface communication between TRCM and A/D/S-MAN. Functions 5–7 represent A/D/S-MAN. A/D/S-MAN generally re-evaluates whenever there is an update to the air traffic system. As opposed to the TRCM’s time-based re-planning cycles, A/D/S-MAN uses event-based re-planning cycles. Whenever there is an event occurring to a flight such as clearance inputs from controllers, non-occurrence of expected events, and deviation from previously planned events including a configuration change event, etc., the corresponding tool is triggered for re-planning. After any re-planning cycle of A/D/S-MAN, an

update on flight information takes places (F.8) so that TRCM has access to the latest flight information for its next planning cycle.

Function 3 requires controller interactions with the integrated tool. If controllers fail to interact with the tool, then the tools default to “no system change.” The tools continue their planning with the existing information as they are the latest information the tools have. Function 8 may require controller interactions, but an automatic retrieval may be conceivable.

As already mentioned in section 4.1, there is also an N2 chart corresponding to the functional flow block diagrams. It is a way to display the information flows between all the different functions of the integrated system design. All functions are put in the diagonal of a matrix. Information that goes from function to a following function is displayed at the right side and is located above the function that receives it. Information that goes from a function to a previous function is displayed at the left side and stands below the function that receives it. Information that stands above the level of function (F.1) comes from outside the whole system.

Figure 2 is a snapshot of the N2 chart that corresponds with the integrated system shown in Figure 1. It is based on the defined data categories to keep it readable (see section 4.2). The color coded cells from Figure 2 can also be referred to Table 3 for specific data requirement for each respective tool.

In the next subsections, the lower-level FFBDs are shown and described. It is important to note that the lower-level FFBDs provided here are based on the research states as of September 2014. As the research in A/D/S-MAN progresses, these FFBDs may need to be revised accordingly.

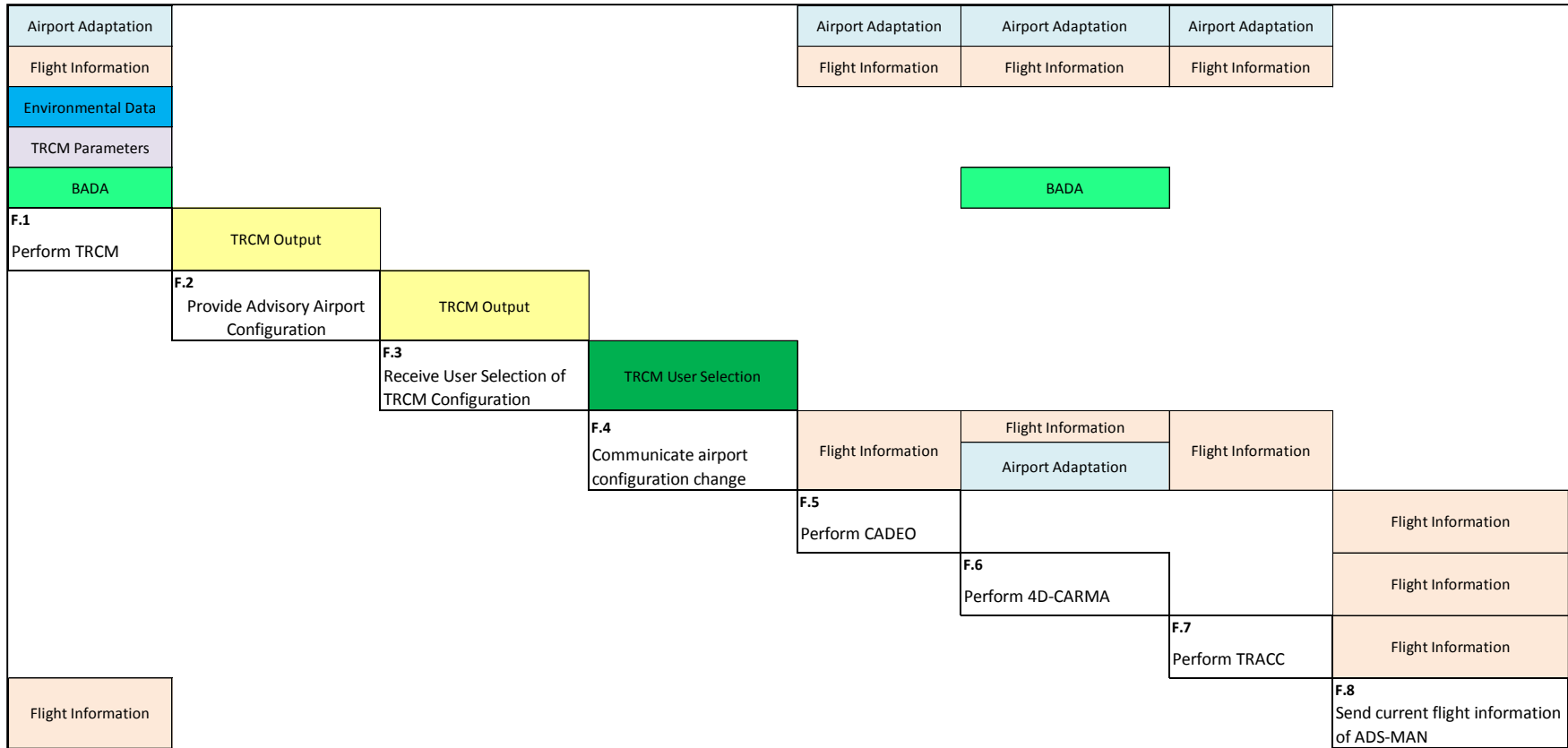

Figure 2: Preliminary N-squared chart for the Arrival/Departure/Surface Management and Tactical Runway Configuration Management integration.

4.3.1. Perform Tactical Runway Configuration Management (TRCM) Function (F.1)

This function (Figure 3) receives three types of information: static information (F.1.1), dynamic information (F.1.2), and user preference's TRCM parameters (F.1.3). The updated flight information from A/D/S-MAN (via F.8) is a part of the dynamic information (F.1.2).

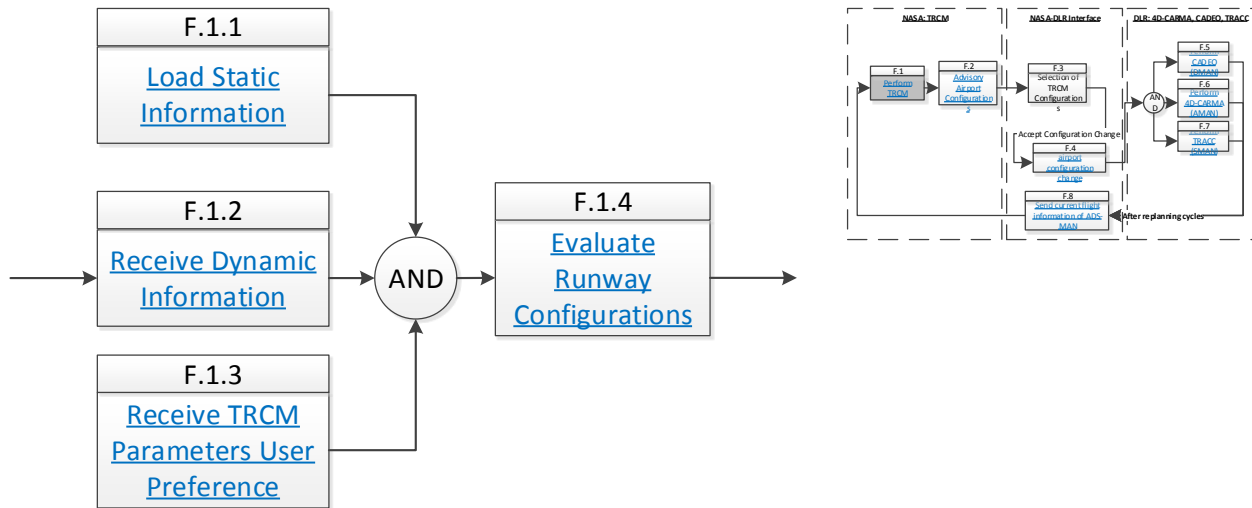

Figure 3: Perform Tactical Runway Configuration Management function (F.1).

4.3.1.1. Load Static Information Function (F.1.1)

Function 1.1, *Load Static Information* (Figure 4), generally relates to airport-specific physical information (F.1.1.1 to F.1.1.11), compliances to FAA or ICAO regulations (F.1.1.12 to F.1.1.13), and BADA aircraft database (F.1.1.14 to F.1.1.16). The airport-specific physical information include all (inactive and active) runways, arrival and departure fixes, spots (only for U.S. airports, the hand-off location between the ramp and tower controllers, or a separation of movement and non-movement surface area), gates, taxiways (node-link surface network), and airlines. TRCM also requires operational and/or modeling information that assigns airline to gate, assigns gate to spot, assigns spot to taxiway, defines runway policy⁷, and defines variable taxi time. For German airports, there is no spot on the airport surface area. As such, TRCM requires an assignment of gate to taxiway directly.

Compliances to FAA or ICAO regulations are flight rules, either instrument (IFR) or visual (VFR), for aircrafts, which in turn, define the wake vortex separation standard according to the regulations. Wake vortex separation standard depends on the weight class of aircraft. Weight class of aircraft can be retrieved from BADA aircraft database along with its taxi, take-off, and landing speeds. TRCM uses all compliances, taxi, take-off, and landing speeds to calculate the earliest times at runway for all flights during the planning horizon.

⁷ Runway policy determines how arrival and departure fixes are assigned to runways.

For the long-term flight dynamic information, TRCM receives this information from the flight plan, usually available in the Collaborative Decision Making (CDM for German system) or traffic flow management systems, for flights with the planning horizon beyond the short-term duration (i.e., long-term). TRCM currently plans for the next 90 minutes. Only flights having the unimpeded⁸ time at gate/ spot (departures) or the unimpeded time at arrival fix (arrivals) that falls within the next 90 minutes are used by TRCM to determine the optimal configurations.

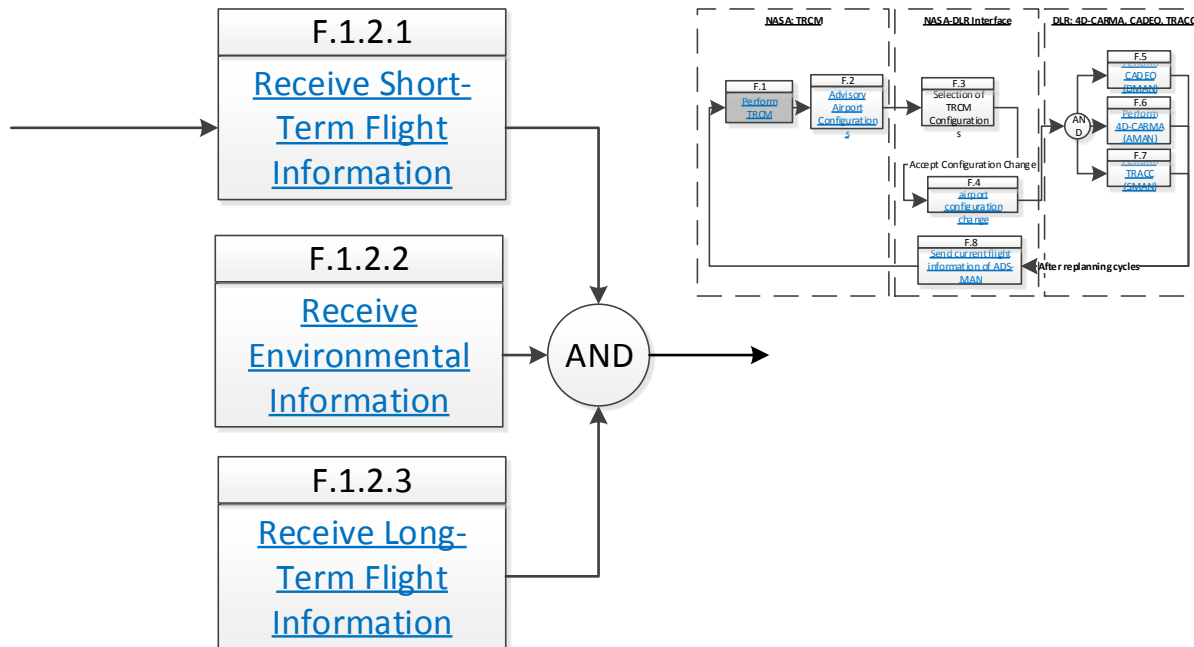

Figure 5: Receive dynamic information function (F.1.2).

4.3.1.3. *Receive Tactical Runway Configuration Management (TRCM) Parameters User Preference Function (F.1.3)*

This function (Figure 6) allows the controllers (users) to change parameters used in TRCM. The controllers can define (1) the baseline configuration (usually is the current active configuration), (2) a list of all configurations to be evaluated, (3) freeze and planning times, (4) minimum time between configuration changes, (5) runway policy, and (6) performance metric used as an objective function.

The freeze horizon is the time duration (from current time) where the algorithm will not generate a new runway configuration recommendation. Currently, TRCM defines this freeze horizon as the next 45 minutes. The *planning horizon* is the time duration (from current time) where TRCM looks ahead. The current TRCM tool defines this as the next 90 minutes from current time. Because the first 45 minutes is the freeze horizon, runway configuration changes are only allowed in the last 45 minutes.

Having a *minimum time between changes* prevents excessive recommended configuration changes. TRCM only considers the next change at least this minimum from the last change. The current algorithm defines

⁸ Unimpeded time is the earliest time for the aircraft if it is the only aircraft in the system.

this as 30 minutes. If the last change occurred at time 1:00 pm, then the next change TRCM could consider is at 1:30 pm because of the 30 minute minimum time between changes.

The *runway policy* relates to the way in which TRCM assigns aircraft to the active runways, given that there is more than one active runway. The users assign arrival and departure fixes to runways. If any fix is assigned to more than one active runway, the users need to define the rule on how to select the runway. This rule (often referred to as runway policy) generally can be either a runway balancing concept, “taxi easy” (shortest taxi distance), or “taxi right” (based on fix location). TRCM checks any aircraft with the defined fix to determine how to assign a runway to the aircraft. If there is more than one active runway available (because the fix is assigned to more than one active runway), then TRCM uses the runway policy that users defined earlier to make the runway assignment.

The users can define which *performance metric* to be considered as the objective function in TRCM. The current algorithm uses total travel time (between fixes and gates) of all aircrafts during the next 90 minutes as the objective. Any configuration schedule that minimizes this total will be the optimum configuration.

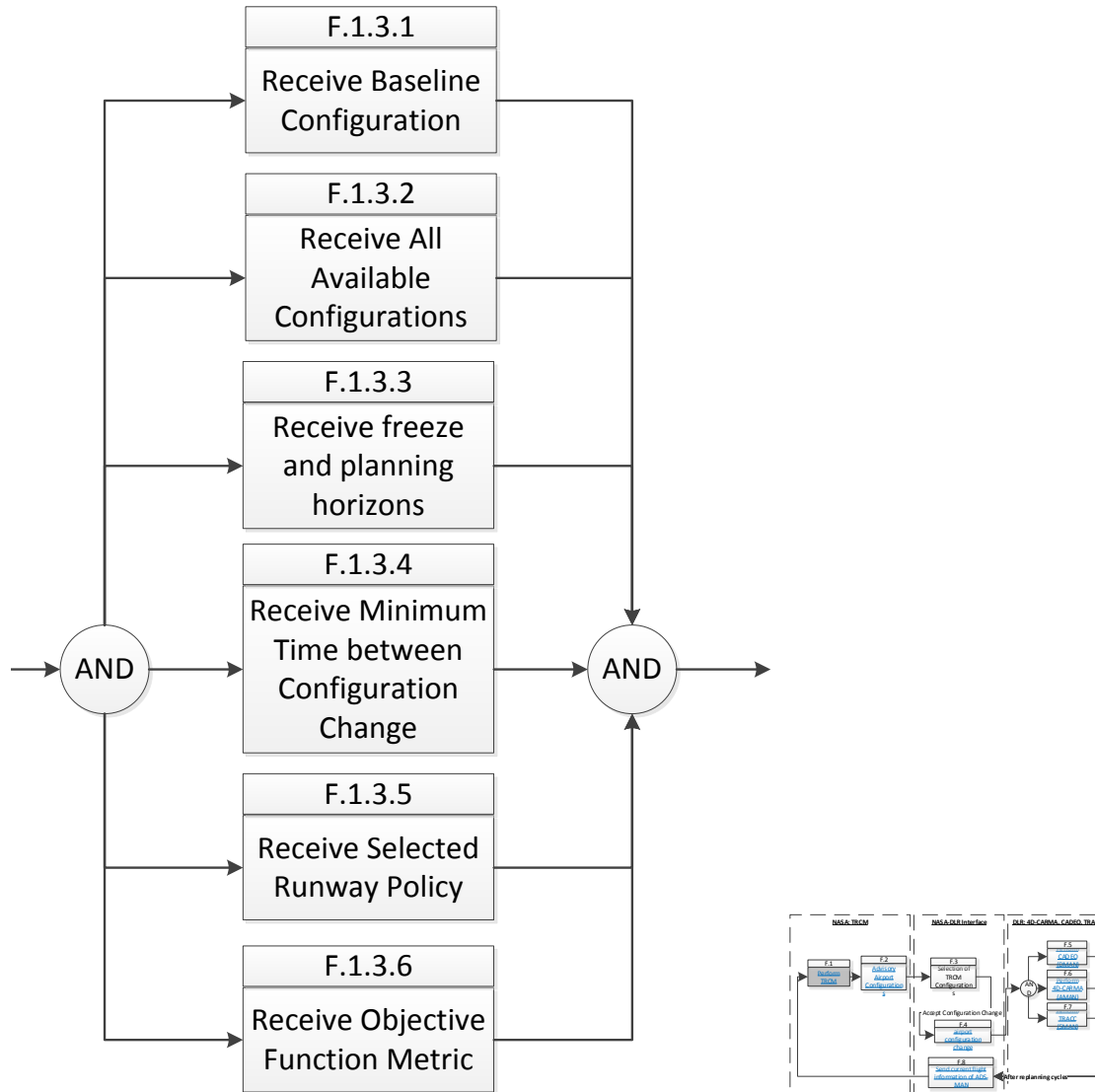

Figure 6: Receive Tactical Runway Configuration Management parameters user preference function (F.1.3).

4.3.1.4. Evaluate Runway Configurations Function (F.1.4)

TRCM performs re-planning every 15 minutes. It takes all flights with the unimpeded time at gate/spot (departures) or the unimpeded time at arrival fix (arrivals) within the next 90 minutes into consideration for each planning cycle. It evaluates the current active (baseline) configuration by using all inputs in functions 1.1, 1.2, and 1.3 in calculation of the earliest times at runway for all flights during the planning horizon of 90 minutes (see Figure 7). These earliest times at runway are then used to sequence flights based on a first-in-first-out rule. That is, flights with the earliest times at runway will be the first in sequence, and flights with the latest times at runway will be the last in the sequence. TRCM uses the wake-vortex separation standards to ensure that there is no violation on the separations between pairwise flights in the sequence. TRCM uses a simple queuing-based performance prediction to compute travel time (between fixes and gates) for all flights. The objective function for current TRCM is to calculate the travel times of all flights. This objective value is recorded for the baseline configuration.

TRCM next evaluates all available configurations. The evaluation is similar to that of the baseline. After evaluations of all configurations, only the best configuration (with the minimum objective function) is recorded and recommended as the optimal configuration.

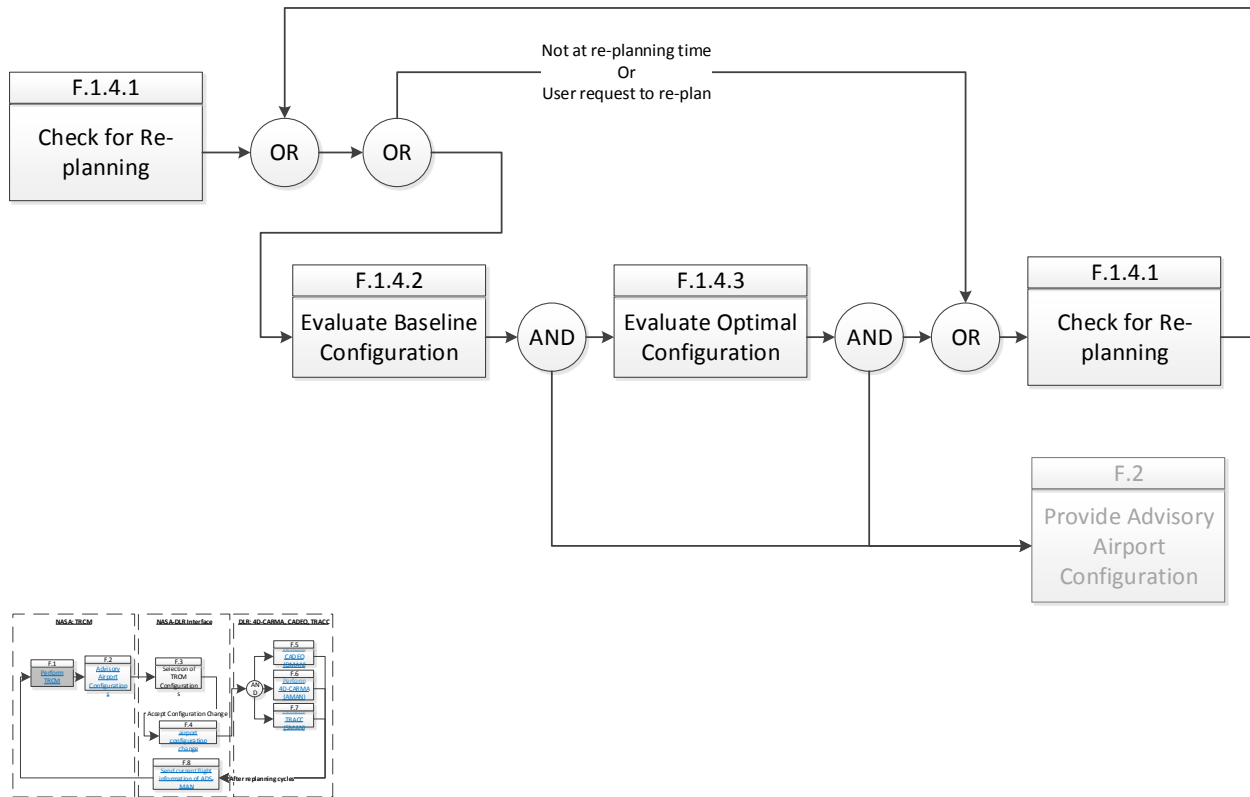

Figure 7: Evaluate runway configurations function (F.1.4).

4.3.2. Provide Advisory Airport Configurations Function (F.2)

After TRCM completes the evaluation from the previous section (F.1), it then provides the advisory airport configurations to the users (controllers). Figure 8 depicts the lower-level diagram for function 2, *Provide Advisory Airport Configurations*. Two sets of configurations are available to the controllers: baseline configuration (F.2.1) and TRCM-based configuration (F.2.2). For each set, configuration, its corresponding objective function value, and the corresponding flight list (the flight-to-runway assignment list) are given.

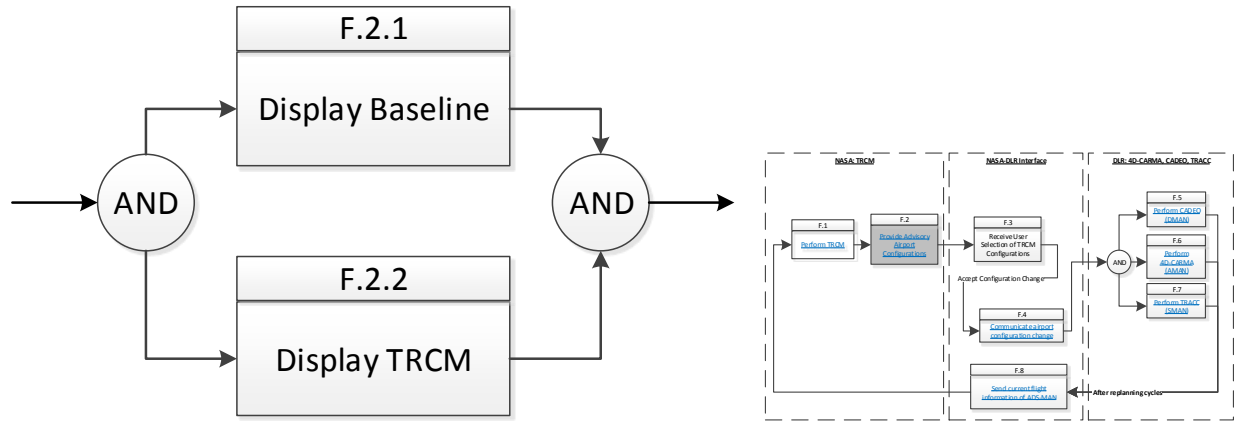

Figure 8: Provide advisory airport configuration function (F.2).

4.3.3. Receive User Selection of Tactical Runway Configuration Management (TRCM) Configurations Function (F.3)

After TRCM provides advisory configurations to users, who make runway management decisions (usually supervisors or traffic flow managers) in the approach and departure control facility and the airport traffic control towers (F.2), the users can select to accept or reject the recommended configuration (F.3). The rejection of the recommended configuration implies no change to the current active configuration, and TRCM will wait until the next planning cycle to repeat the evaluation process. The airport configuration and the flight-to-runway assignment are only updated by function 4 if the recommended configuration is accepted.

4.3.4. Communicate Airport Configuration Change Function (F.4)

Figure 9 gives the lower-level diagram for function 4, *Communicate Airport Configuration Change*. The earliest configuration change time recommended by TRCM is 45 minutes ahead (configurable). Therefore, there is no change to the short-term flight information, which is within the 45 minute period. There is no impact on the A/D/S-MAN for the current planning cycle (< 45 minute horizon.) The recommended change will trigger their future re-planning cycles. For 4D-CARMA, the recommended change time and the new configuration will be input into its database for future re-planning cycles in function 4.1. For CADEO and TRACC, because future flights have not started taxiing, the only update for these flights is done by operators responsible for revising their flight plans to reflect the recommended configuration change (F.4.2). The CADEO and TRACC will then use the latest flight plans in the future re-planning cycles.

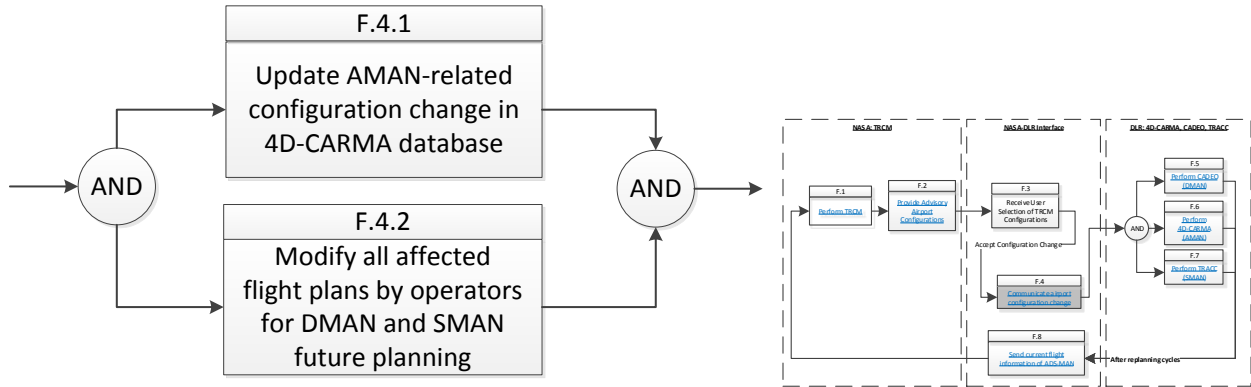

Figure 9: Communicate airport configuration change function (F.4).

4.3.5. Perform Departure Management - Controller Assistance for Departure Optimization (CADEO) Function (F.5)

CADEO’s main functionalities are displayed in Figure 10. This function receives two types of information: static information (F.5.1) and dynamic information (F.5.2). It then uses the information to sequence departures (F.5.3). Once the sequence is calculated, it is given to the controllers for clearance advisories along with TSAT and TTOT (F.5.4).

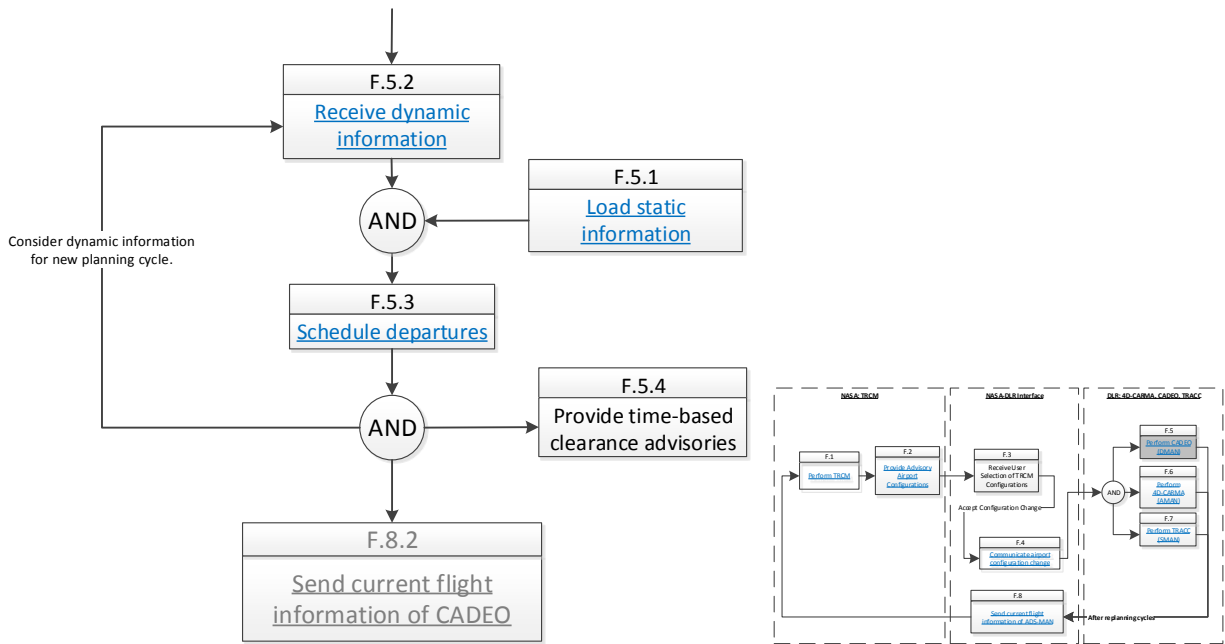

Figure 10: Perform Departure Management - Controller Assistance for Departure Optimization (CADEO) function (F.5).

Generally, CADEO uses the required data to schedule or plan departing aircraft within its planning horizon. It considers all departures within 20 minutes (configurable) prior to their TOBTs to determine the departure schedule. The tool re-plans whenever certain events occur in the air traffic system. Examples of updates that will trigger the re-planning are clearance inputs of controllers, non-occurrence of expected events, or any deviation to the previously planned events. The planning horizon is flight-based, and begins

20 minutes before the departure's off-block and ends when it departs. In other words, each departure has its own planning duration depending upon the traffic demand surrounding the departure. For example, departures during the busy hours (peak demand) generally have longer planning durations than those of the off-peak-hour departures. When there is a configuration change recommended by TRCM and it is accepted by the controllers at least 45 minutes ahead (i.e., at the end of TRCM's freeze horizon), there are two possible groups of departures. The first group is for departures with the old departure runway before the change time. The second group is for departures with the new departure runway after the change time. For the first group, a TRCM recommendation does not affect how CADEO operates. For the second group, since the configuration change is known 45 minutes in advance, flight plans which are part of the dynamic information (F.5.2) have to be modified by the responsible operators accordingly. CADEO has to ensure safe coordination between the two departure groups. For example, sufficient time separation between the departing aircraft of the old and the new configurations must be used if they are on the same runway moving in opposite flow directions. This implementation needs further evaluation if this function is part of automation or operator responsibility.

4.3.5.1. Load Static Information Function (F.5.1)

Figure 11 shows the lower-diagram for *Load Static Information*. Static information usually does not change frequently within the planning horizon time. The information includes runways, standard instrument departures (SIDs), variable taxi times (VTTs), controller working positions (F.5.1.8), and departure runway separations for departure-departure pairwise separations (F.5.1.5 to F.5.1.7). Controller working positions are important for CADEO in order to provide time-based clearance advisories appropriate to all air traffic controllers' working positions: clearance delivery, apron (ramp), ground, and local controllers.

Note that in referring to the Figure 11, the application of departure separation standards represent those used in the German system although there are similarities with the U.S. system. There are three types of separation criteria applied to departing aircraft: (1) wake vortex separations (F.5.1.5), (2) separations for aircraft that will fly a SID (F.5.1.6), and (3) speed separations (F.5.1.7). Wake vortex separations are normally dependent on the ICAO classification of aircraft. The separation values for the airport are provided to CADEO as a predefined data table. Departure runway SID separations and speed separations are dependent on the first turn in the SID of departures, regardless of the direction of their routes. The time separation or speed separation required between two flights sharing the same or common-path SIDs are provided to CADEO as predefined data tables. Separation is irrelevant between two flights with their first turns in different paths. When more than one pairwise separation is available, the greater separation will be used in CADEO to guarantee compliance with regulations.

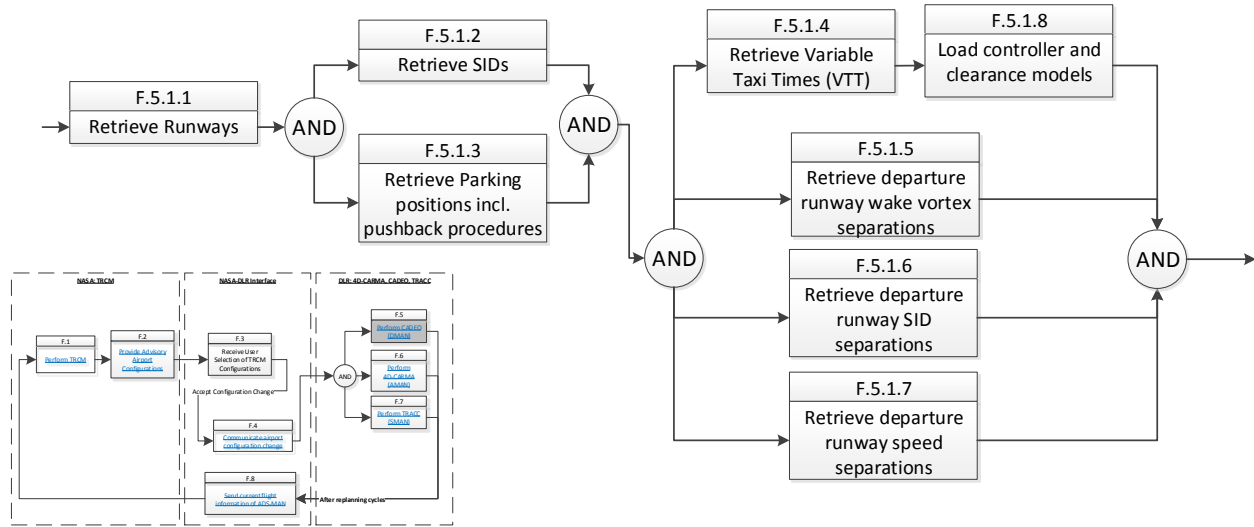

Figure 11: Load static information function (F.5.1).

4.3.5.2. Load Dynamic Information Function (F.5.2)

Dynamic information (Figure 12) for each departure includes flight information, taxi clearance inputs from the controller, and position information by A-SMGCS (a.k.a. ASDE-X in the U.S., see section 3.1) Flight information includes flight plan, call sign, assigned runway, assigned gate, and (dynamic) target off-block time (TOBT⁹). If CADEO has not received confirmation for taxi clearance from the controller, the tool will re-compute the target start-up approval time (TSAT¹⁰) for this departure during the next planning cycle.

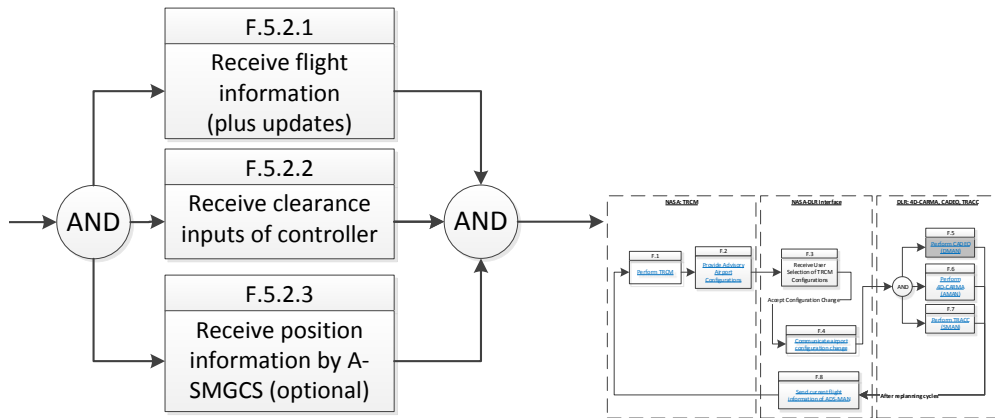

Figure 12: Receive dynamic information function (F.5.2).

⁹ TOBT is the time that an aircraft operator or ground handler estimates that an aircraft will be ready, all doors closed, boarding bridge removed, push-back vehicle available, and ready to start up / push back immediately upon reception of clearance from the TW. R.

¹⁰ TSAT is the time provided to air traffic controller taking into account target off block time (TOBT), calculated take-off time (CTOT) and/or the traffic situation that an aircraft can expect start-up / push back approval. CTOT is the time calculated and issued by the traffic flow management, at which a flight is expected to become airborne.

4.3.5.3. *Schedule Departures Function (F.5.3)*

Figure 13 shows the lower-level diagram for function 5.3, *Schedule Departures*. CADEO tool uses the required information in function 5.1 and function 5.2 to schedule departing aircraft within 20 minutes prior to their TOBTs. CADEO calculates the earliest take-off time (ETT) of all departures using the TOBT and variable taxi times (VTTs). The tool also retrieves the target landing times (TLDTs¹¹) of all arrivals from AMAN at the time of planning cycles. It then uses both ETT and TLDT, along with any required departure runway separations (from F.5.1), to determine the optimal departure sequence at the departure runway. Once CADEO computes the target take-off times (TTOTs), the departure sequence is determined. Based on the TTOT, the TSATs are determined for all departing aircraft by back calculating from TTOT.

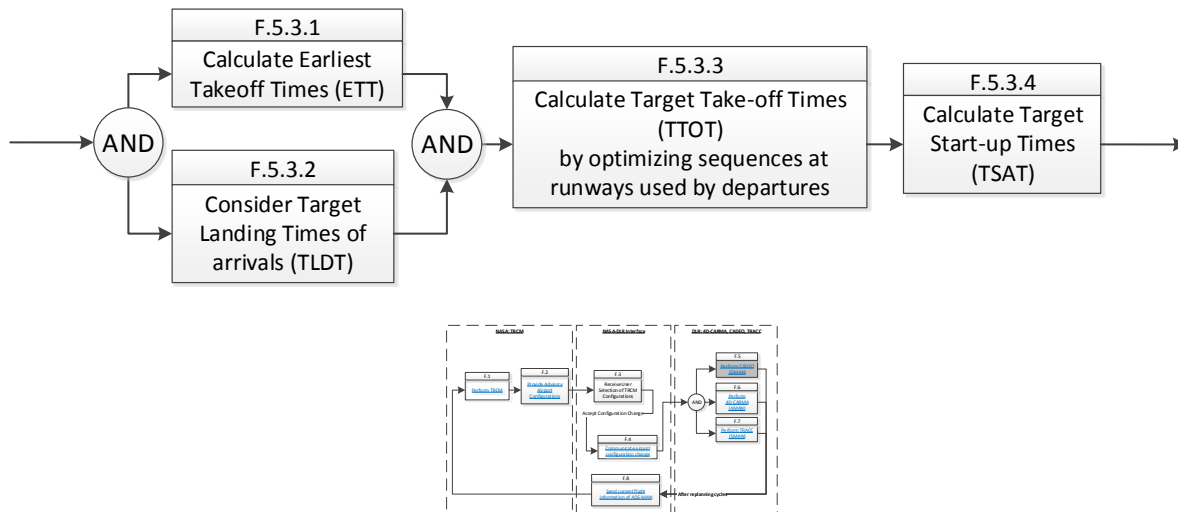

Figure 13: Schedule departures function (F.5.3).

4.3.5.4. *Provide Time-Based Clearance Advisories Function (F.5.4)*

This function provides the recommended time-based clearance advisories to the controllers. When controllers confirm the clearance, CADEO will receive this input through function 5.2. If controllers do not confirm the clearance, CADEO will assume there is a non-occurrence of expected prior events (e.g., push back needs longer time, etc.) for this departure causing the controllers to fail to confirm departure clearance. CADEO will continue to re-compute this departure’s TTOT and/or TSAT in the next re-planning cycle.

4.3.6. **Perform Arrival Management – 4 Dimensional Cooperative Arrival Manager (4D-CARMA) Function (F.6)**

The main functionalities of 4D-CARMA are displayed in Figure 14. This function receives two types of information: airspace information (F.6.1) and dynamic information (F.6.2). It then uses the information to schedule or plan arrivals (F.6.3). Once the arrival schedule is planned, it is given to the controllers with guidance instructions for implementation (F.6.4).

¹¹ TLDT is the target time from the Arrival management process at the runway threshold, taking runway sequence and constraints into account.

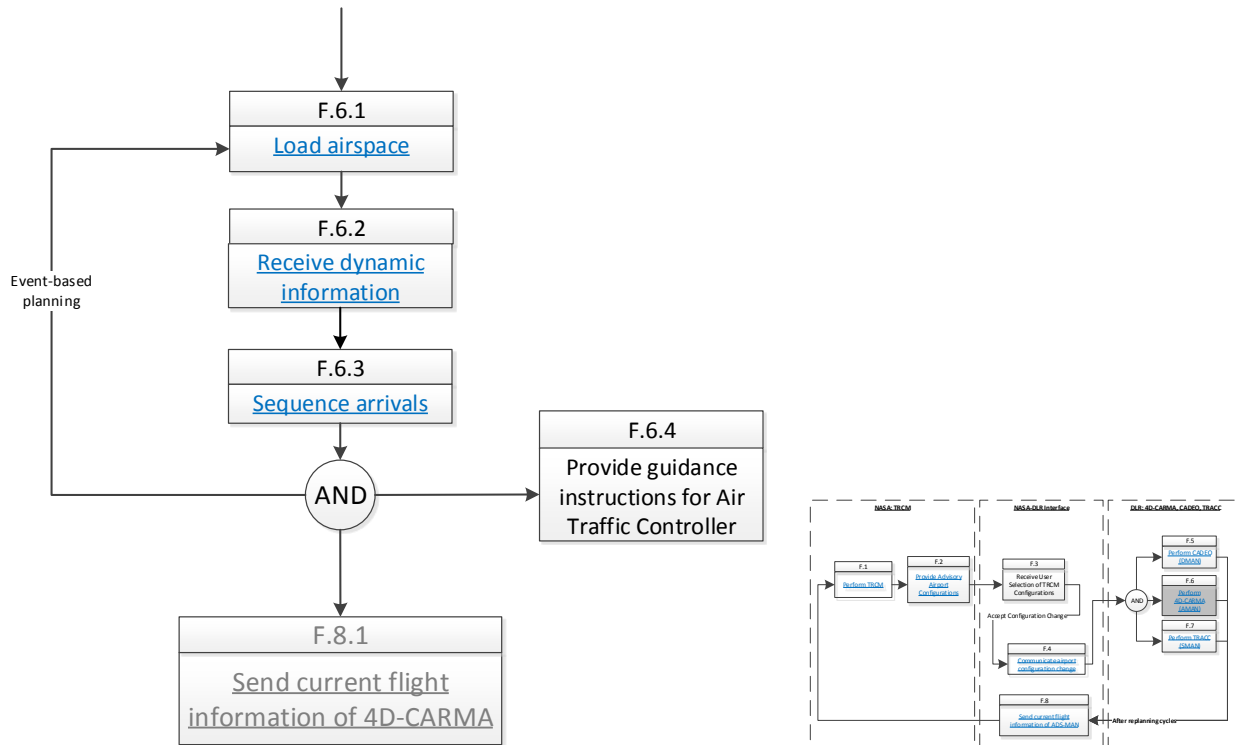

Figure 14: Perform Arrival Management – 4 Dimensional Cooperative Arrival Manager (4D-CARMA) function (F.6).

Generally, 4D-CARMA tool uses the required data to schedule or plan arriving aircraft within its planning horizon. Each arrival has its own planning duration (similar to the DMAN concept), depending on the traffic demand. The planning horizon for each arrival begins when the arrival enters a pre-defined radius around the airport (or terminal airspace), and ends when it passes the runway threshold. 4D-CARMA detects arrivals entering the approach control airspace serving the airport. It then takes all of these arrivals to sequence for an arrival runway. The tool re-plans whenever there is an update of the flight or position information.

When there is a configuration change recommended by TRCM, and it is accepted by air traffic personnel (supervisors or traffic flow managers), arrivals are divided into two groups for the purpose of runway assignment. The first group is for arrivals with their earliest and latest arrival times at the runway thresholds before the change time. Specifically, the arrival time intervals are before the change time. For the first group, there is no impact on the arrivals with respect to runway assignment. The second group is for all other arrivals. For this group, a new configuration will trigger a change in the airspace layout in function 6.1. The change in the airspace layout will be used in the future re-planning cycles for arrivals in the second group. Currently there is no implementation of the transition from one configuration to the other. Because of the planning horizon of TRCM, all affected aircraft of the second group are not yet in the approach airspace of the airport. Flight operators have to be informed by the air traffic controllers in the ACCs (enroute control centers as defined in Table 1) before entering the approach airspace. As the affected aircraft enters the approach airspace, it will be detected by 4D-CARMA. The tool will include this aircraft in the future planning cycles with the new airspace layout corresponding to the new configuration.

4.3.6.1. Load Airspace Function (F.6.1)

This function (Figure 15) loads an airspace model necessary for the 4D-CARMA tool. Approach routes and active runways vary depending upon the runway configuration. All possible routes for all possible configurations must be modelled before running the integrated system.

The airspace model data for all possible configurations includes active runways (F.6.1.3), airport-specific runway-to-STAR assignment (F.6.1.4), routes from the arrival fix to the runway threshold (F.6.1.5), and waypoints with altitude and speed constraints (F.6.1.6).

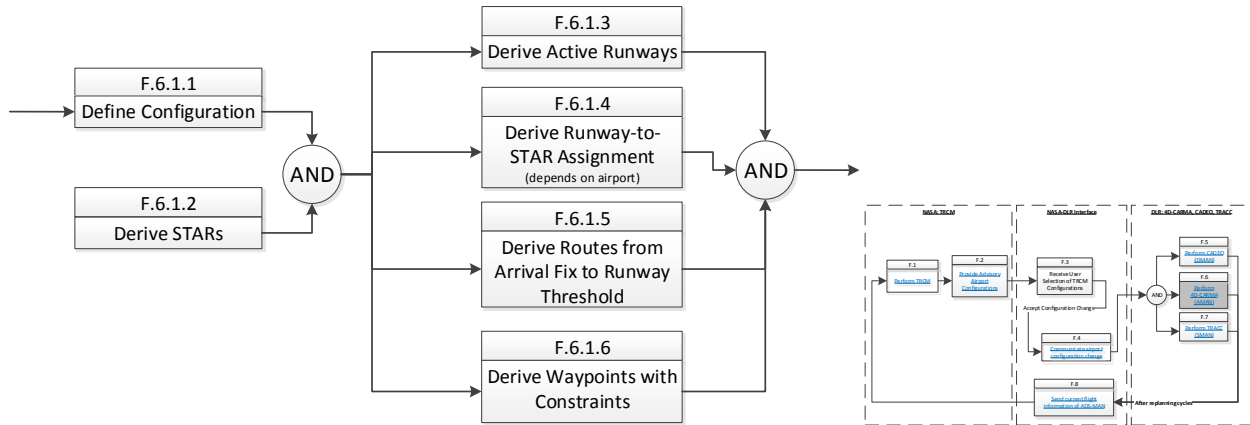

Figure 15: Load airspace function (F.6.1).

4.3.6.2. Receive Dynamic Information Function (F.6.2)

This function (Figure 16) receives flight information and radar data for all arrivals within the approach airspace. Flight information includes flight plan, call sign, and assigned runway. The radar data gives aircraft current positions and is updated every five seconds to reflect the latest aircraft positions. In 4D-CARMA, there is no input from the controller. The impact of controller commands, given through voice communication, can be seen only through an update of radar data. Meanwhile there is an on-going research to extent 4D-CARMA by automatic speech recognition to react much faster and more accurate to changes (ref. 15).

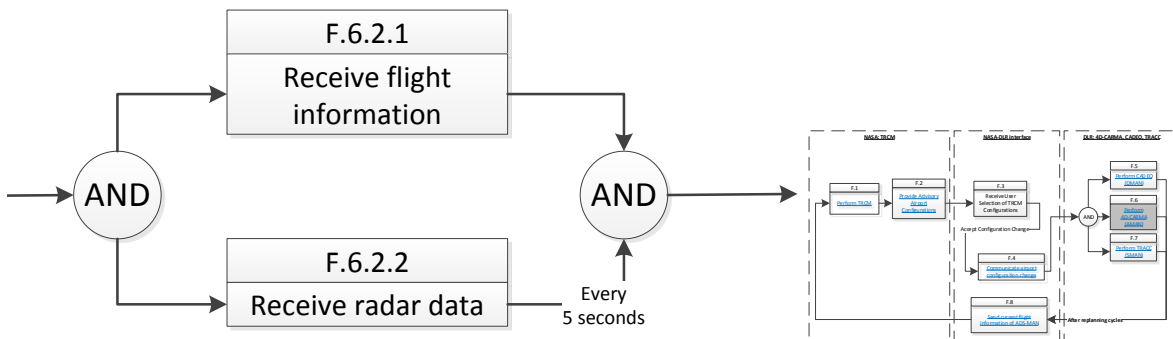

Figure 16: Receive dynamic information function (F.6.2).

4.3.6.3. *Sequence Arrivals Function (F.6.3)*

Figure 17 shows the lower-level diagram for function 6.3, *Sequence Arrivals*. The 4D-CARMA tool uses the airspace layout (from F.6.1) along with aircraft radar data (from F.6.2) to predict the shortest and longest routes from their current position to the active runways (F.6.3.1). Given the known aircraft make and model from the flight plan, the tool uses the BADA database to determine aircraft-specific approaching speeds and descent profiles. Using the shortest and longest distances along with the aircraft-specific approaching speeds and descent profiles, 4D-CARMA calculates the earliest and latest arrival times (or the arrival time intervals) at the runway threshold for all arrivals within the approach airspace (F.6.3.2). These predicted arrival time intervals are then used to sequence all arriving aircraft at the threshold based on a scheduling constraint set of conflicting objectives (F.6.3.3 and F.6.3.4). Given the arriving sequence from F.6.3.4, the tool then computes the required time of arrivals (RTA) at the runway threshold with a consideration of wake vortex separations. 4D-CARMA predicts 4D-trajectories (F.6.3.6 to F.6.3.7) for all arriving aircraft to meet the computed RTA. The prediction of the RTA 4D-trajectory is done using an aircraft-specific approaching speed and descent profile from the BADA database.

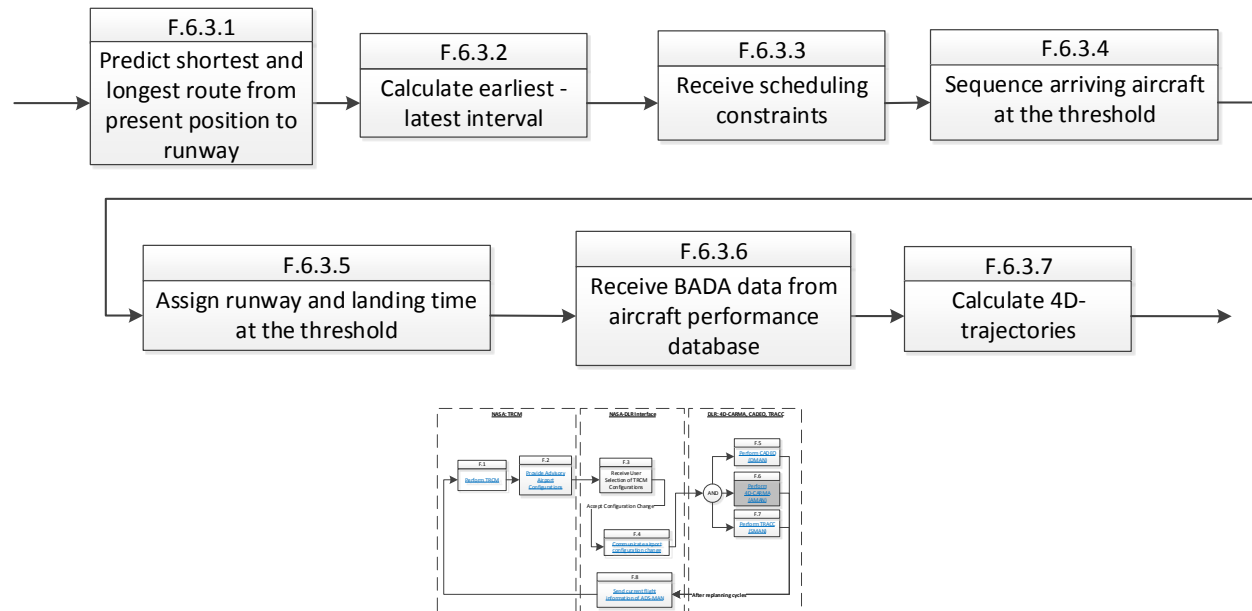

Figure 17: Sequence arrivals function (F.6.3).

4.3.6.4. *Provide Guidance Instructions for Air Traffic Controller Function (F.6.4)*

The predicted RTA 4D-trajectory, RTA at the threshold, and the landing sequence number (from the arrival sequence) are displayed to the controller along with specific guidance instructions (e.g., speed, descent, turn, etc.) for implementation.

4.3.7. Perform Surface Management - Taxi Routing of Aircraft: Creation and Controlling (TRACC) Function (F.7)

Figure 18 shows the functional flow diagram of TRACC. This function receives two types of information: airport-specific node-link models (F.7.1) and dynamic information (F.7.2). It then uses the information to

calculate surface trajectories (F.7.3). Once the surface trajectories are planned, they are provided to the controllers together with guidance instructions (F.7.4.) for implementation.

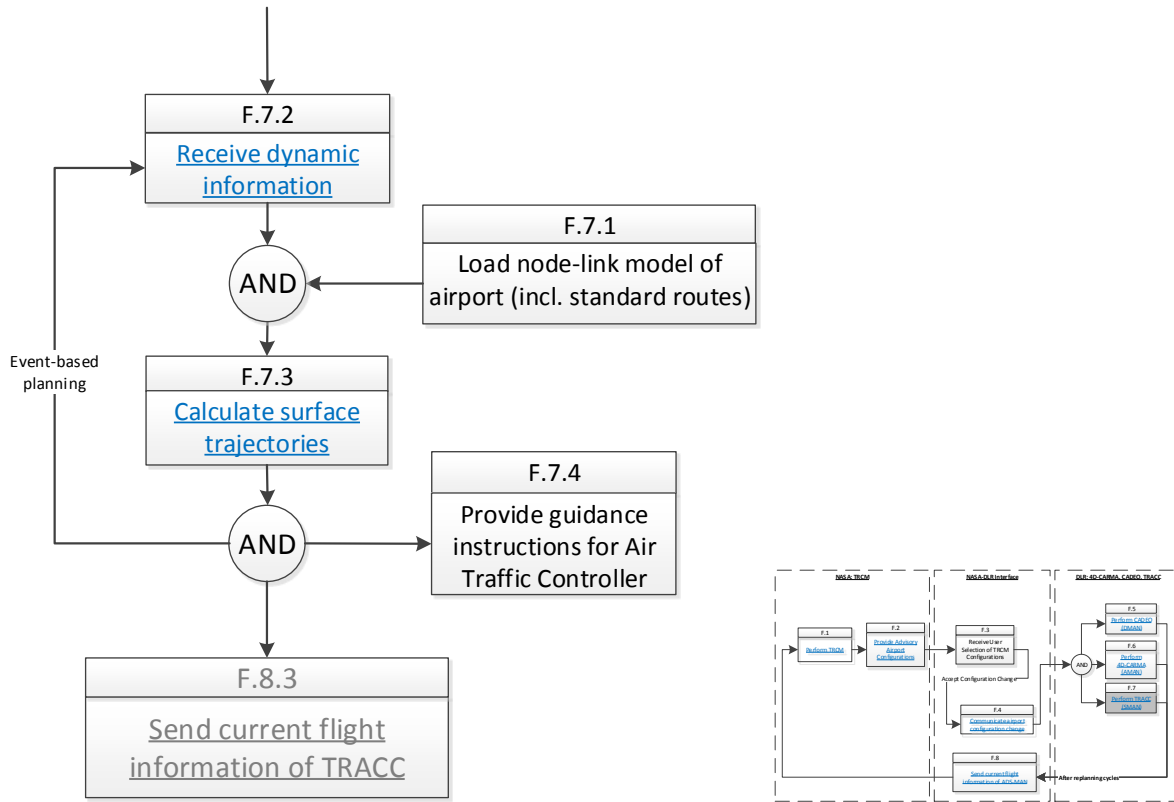

Figure 18: Perform Surface Management - Taxi Routing of Aircraft: Creation and Controlling (TRACC) function (F.7).

Generally, TRACC uses the required data to plan conflict-free optimized taxi routes for all aircraft which are close to their landing or off-block times (approximately five minutes before landing or off-block times). All aircraft meeting this criterion are put into an internal flight list. The internal flight list contains all flights (arrivals and departures) to be optimized by TRACC. The optimization process can occur for two cases. First, there is a new aircraft introduced into the planning horizon. Second, TRACC detects a deviation from the previously planned taxi route or taxi time of any existing aircraft which leads to conflicts or a missed target time. As soon as departures/arrivals reach their departure runways/their arrival gates, TRACC will no longer optimize their taxi-routes.

When there is a configuration change recommended by TRCM and it is accepted by the controllers at least 45 minutes ahead (i.e., at the end of TRCM’s freeze horizon), there are two possible groups for departures and two groups for arrivals. The first group is for departures with the old departure runway before the change time. There is no impact of TRCM recommendation to this first group. The second group is for departures with the new departure runway after the change time. Since the configuration change is known 45 minutes in advance, the second group’s flight plans which are part of the dynamic information (F.7.2) will be modified by ATC accordingly.

For arrivals, the first (second) group is for arrivals with their touchdown times before (after) the change time. There is no impact of TRCM’s recommendation to the first group of arrivals. Since the TRACC’s optimization process begins five minutes before landing, TRACC uses the most recent information about landing time and runway to provide a conflict-free taxi route for all aircraft for the second group. A possible configuration change has not been tested yet.

4.3.7.1. Load Node-Link Model of Airport Function (F.7.1)

TRACC loads the airport-specific node-link surface model which will be used to determine a conflict-free taxi-route in the downstream function (F.7.3). If the airport has a predefined set of standard taxi routes, TRACC will include these routes as part of the node-link surface model.

4.3.7.2. Receive Dynamic Information Function (F.7.2)

Dynamic information (Figure 19) for each aircraft includes flight information, clearance inputs from controller, and position information by A-SMGCS (a.k.a. ASDE-X in the U.S., see section 3.1). Flight information includes a flight plan, call sign, assigned runway, assigned gate, TOBT (for departures), and TLDT (for arrivals). In case there is no “target” time available, TRACC will use the estimated landing/departure times. If those estimated times are not available, TRACC will use the scheduled landing/departure times. Flights without any of these time values will not be optimized or even considered by the tool.

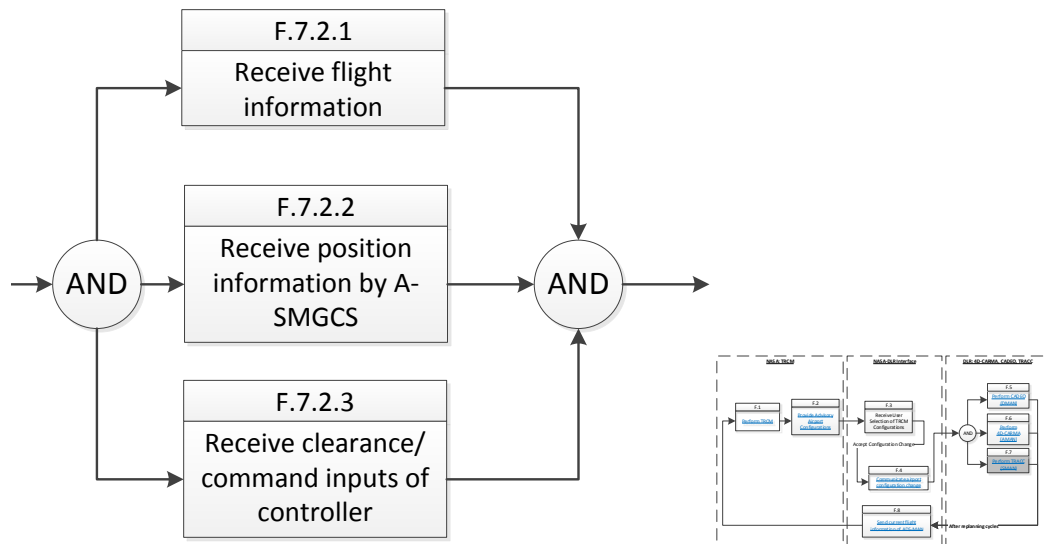

Figure 19: Receive dynamic information function (F.7.2).

4.3.7.3. Calculate Surface Trajectories Function (F.7.3)

Figure 20 shows the lower-level diagram for function 7.3, *Calculate Surface Trajectories*. Generally, the TRACC tool uses the required data from function 7.1 and function 7.2 to plan conflict-free and optimized taxi-routes for all flights in its internal flight list. The internal flight list contains all flights with approximately five minutes before landing (arrivals) or with approximately five to fifteen minutes before off-block (departures). These flights have not yet reached their arriving gates or departure runway.

The optimization can occur for two cases. First, there is a new aircraft introduced to the internal flight list. The TLDTs (arrivals) and TOBTs (departures) are used to determine when they are to be considered as a new aircraft. A standard taxi-route from a set of predefined airport-dependent routes is allocated to the new aircraft. For arriving aircraft, TRACC selects the most probable runway exit to allocate a taxi route. Five minutes before the TLDT (arrivals) and approximately five to fifteen minutes before TOBT (departures) of the new aircraft, TRACC will optimize the taxi route of this aircraft. Second, TRACC detects a deviation from the previously planned taxi route or taxi time of any already taxiing aircraft. For this case, TRACC will adapt the planned trajectory to the actual position and speed, and check the new trajectory for conflicts or missed target times. If a problem occurs, TRACC will re-optimize only the flight with deviation.

Both cases, the time optimization algorithm (TOA) is triggered (F.7.3.2) in an attempt to evaluate an optimal speed profile for the deviated taxi-route of the aircraft. The deviated taxi-route can be either the standard taxi-route (for the first or second cases) or the adapted taxi-route from previous optimization cycle(s) (for the second case). If speed solution from the TOA is not sufficient, TRACC will re-optimize this flight for a better route using a more complex algorithm called the route optimization algorithm (ROA) as shown in F.7.3.5. In other words, TRACC will not try to change other flights' planned speed profiles or taxi-routes, but only try to adjust this flight speed or route to have a conflict-free taxi-route with all others' existing routes.

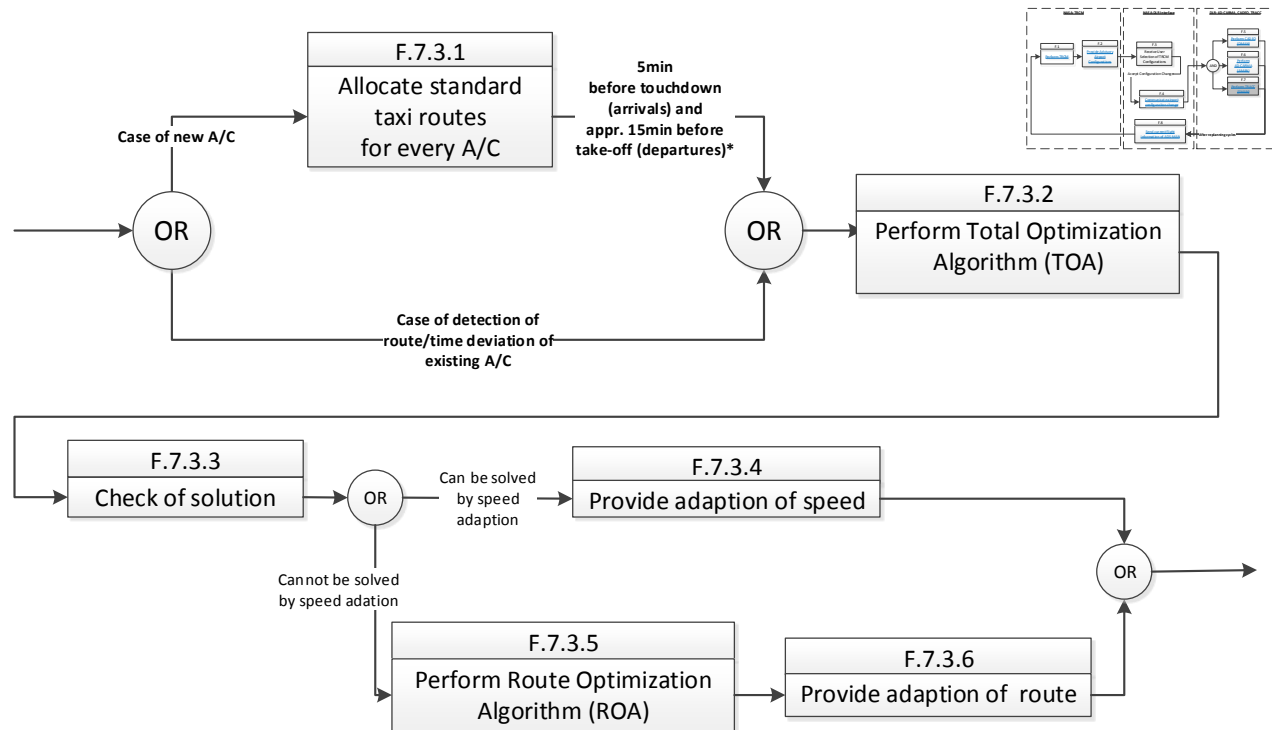

Figure 20: Calculate surface trajectories function (F.7.3).

4.3.7.4. Provide Guidance Instructions for Air Traffic Controller Function (F.7.4)

New aircraft are shown to the controller via a “planned flight list”. The planned flight list is a smaller list (from the internal flight list) to display only to the controller, while the internal flight list is the list for

TRACC to optimize the surface operations. For all new aircraft, the standard taxi-route is provided as the first approach. The controller has an option to view this route by clicking on the flight entry in the planned flight list, but no associated commands are shown at this time. A trajectory with an adjusted speed profile or a completely adapted route is shown to the controller only for optimized aircraft with five minutes before its TOBT or TLDT. Necessary advisories for these optimized trajectories are presented to the controllers (90 seconds plus a command-dependent buffer) before the advisories have to be applied.

4.3.8. Send Current Flight Information of Arrival/Departure/Surface Management (A/D/S-MAN) Function (F.8)

After any re-planning cycle of A/D/S-MAN, an update on flight information takes places in this function so that TRCM has access to the latest flight information for its next planning cycle. This latest information is part of the dynamic information in function 1.2. TRCM uses it in the planning cycle as part of the freeze horizon, where no change can be made to the flights and airport configuration. Figure 21 gives the flow diagram of this function. There are three sub-functions, one for each A/D/S-MAN tools. Each sub-function will provide slightly different flight information, depending on the tool capabilities.

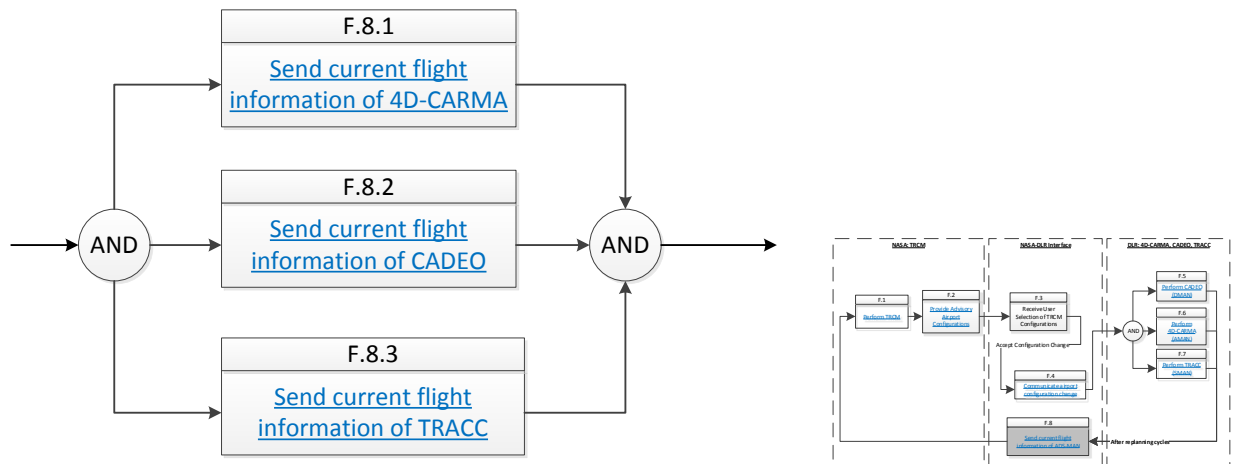

Figure 21: Send current flight information of Arrival/Departure/Surface Management function (F.8).

4D-CARMA (F.8.1) provides three types of information to TRCM: the flight plan, assigned runway for landing, and the TLDT. This information is all part of the short-term flight information. TRCM uses them in its planning cycle as part of the freeze horizon. Similarly, CADEO (F.8.2) provides three types of information to TRCM: the flight plan, assigned departure runway, and the TTOT. They are part of the short-term flight information. TRACC (F.8.3) sends the flight plan, gate information, and the TSAT (for departures) to TRCM as part of the short-term flight information.

5. Conclusions and Recommendations

The German Aerospace Center (DLR) and the National Aeronautics and Space Administration (NASA) have collaborative research effort focused on the integration of arrival/departure/surface management tools and a runway management tool. This document first compares the operational environments for air traffic management (ATM) in Germany and in the United States in which the respective tools were developed.

The basic objectives of the air traffic control systems in Germany and the United States are the same, i.e. to provide for the safe and efficient movement of aircraft. Although fundamentally the same, there are differences in procedures, airspace structure, roles/responsibilities, among others as described in this document.

In a general sense, the problems seem to be the same, though slightly different. In Germany, the general problem is the dense airspace through overflights of European air traffic and the small airport surface. With the consideration of noise abatement and the avoidance of storm cells, the rising traffic demand poses a capacity and efficiency challenge for the airspace area. In the U.S., the problem is the large number of aircraft and in many cases, limited surface area; there are, of course, many other aspects of the air traffic flow process and supporting elements that affect capacity and efficiency. There are on-going research efforts to address many facets of the airspace system in Germany and the U.S.

DLR has developed research prototypes of decision support tools for three well-known concepts in Europe to handle arrival, departure, and surface traffic. Four Dimensional Cooperative Arrival Manager (4D-CARMA) is the DLR arrival management tool that builds an arrival sequence, assigns an arrival time at the runway threshold, predicts trajectories for all aircraft, and transforms them into appropriate guidance instructions for the air traffic controller. For any arrivals, 4D-CARMA's planning responsibility begins when an aircraft enters the terminal maneuvering area, and ends when the aircraft touches down. The corresponding working positions are approach controllers.

Controller Assistance for Departure Optimization (CADEO) is the DLR departure management tool that optimizes the departure sequence at the runways while considering arrivals on the same runway or a dependent runway. For any departures, CADEO's planning responsibility begins approximately 20 minutes before an aircraft's target off-block time (TOBT), and ends when the aircraft departs. The corresponding working positions are local, ground controller, and also clearance delivery controller in the airport traffic control tower.

Taxi Routing of Aircraft: Creation and Controlling (TRACC) is the DLR surface management tool that generates conflict-free taxi routes from gate to runway and vice versa to meet target take-off times (TTOT) with a minimum of speed changes during the taxi process. For any arrivals, TRACC's planning responsibility begins approximately five minutes before an aircraft's target landing time (TLDT) and ends when the aircraft arrives at the gate. For any departures, TRACC's planning responsibility begins approximately five minutes before an aircraft's TOBT and ends when the aircraft lines up for departure. The corresponding working positions are ground controller and apron (ramp) controller either seated in the airport traffic control tower or a dedicated control facility.

NASA has developed a tactical runway configuration management (TRCM) tool that provides runway configuration and runway usage recommendations intended for use by traffic flow managers and supervisors. TRCM makes runway recommendations that optimize overall transit time for arrivals and departures scheduled to be within the terminal boundary for the next 90 minutes from current time. The 90 minute planning horizon used is based on the tactical nature of runway changes.

Functional Analysis of individual tools and of an integrated system are described next. Functional Analysis is a study of process activities that arranges functions in logical sequences, decomposes higher-level functions into lower-level functions, and identifies all internal and external functional interfaces. The tools used to model the functional behavior of a system are functional flow block diagram (FFBD) and N-squared (N2) diagramming techniques. The FFBD technique details the logical and environmental sequence of the system, while the N2 diagramming technique provides the data environment of the system. Both the FFBD and N2 diagrams provide complementary functional behavior of the system.

Because available data sources and data necessary for DLR and NASA tools generally differ, the analysis of the integrated system presented in the document will be at the higher level of details, where the FFBD is applicable to both the German and the U.S. air traffic environments. At the highest level of the integrated system, TRCM evaluates the current and the optimal runway configurations, and repeats the evaluation process at a predetermined time-based planning frequency. At this predetermined re-planning time, TRCM takes snapshots of the current air traffic system as input to its optimization algorithm. TRCM then provides advisory (both the current active and the optimal) configurations along with its performance metrics to the air traffic personnel (supervisors or traffic flow managers). The personnel can choose to accept or reject the recommended configuration. The rejection of the recommended configuration implies no change to the current active configuration, and TRCM will wait until the next planning cycle to repeat the evaluation process. If the recommended configuration is selected, the airport configuration is updated and will be used in planning by arrival, departure, and surface management (A/D/S-MAN) tools. A/D/S-MAN generally re-evaluates whenever there is an update to the air traffic system. As opposed to the TRCM's time-based re-planning cycles, A/D/S-MAN uses flight-based re-planning cycles. Whenever there is an event occurring to a flight such as clearance inputs from controllers, non-occurrence of expected events, and deviation from previously planned events including a configuration change event, etc., the corresponding tool is triggered for re-planning. After any re-planning cycle of A/D/S-MAN, an update on flight information takes place so that TRCM has access to the latest flight information for its next planning cycle. The update of flight information may require controller interactions, but an automatic retrieval may be conceivable. For all tools, if the users fail to interact with the tool, then the tools default to "no system change." The tools continue their planning with the existing information as they are the latest information the tools have.

As the FFBD of the integrated system was assessed in the document, the future collaborative research efforts is to provide a high-level concept of operations (ConOps) detailing how the NASA runway management and DLR arrival, departure, and surface management tools will function together to the benefit of each. Specifically, the future efforts to fully develop the ConOps will include:

- developing scenarios to fully test environmental, procedural, and data availability assumptions;
- executing the analysis by a walk-through of the integrated system using these scenarios;
- defining the appropriate role of operators in terms of their monitoring requirements and decision authority;
- executing the analysis by a walk-through of the integrated system with operator involvement;

- characterizing the environmental, system data requirements, and operator role assumptions for the ConOps.

Acronyms

4D-CARMA	4 Dimensional Cooperative Arrival Manager
A/D/S-MAN	Arrival, Departure and Surface Management System
ACC	Area Control Center
A-CDM	airport collaborative decision making
AIP	aeronautical information publication
AMAN	Arrival Management System
APP	Approach Control Center
ARTCC	Air Route Traffic Control Center
ASDE-X	Airport Surface Detection Equipment, Model X
A-SMGCS	Advanced Surface Movement Guidance and Control System
ATC	air traffic control
ATCO	air traffic control operator
ATCSCC	Air Traffic Control System Command Center
ATCT	Airport Traffic Control Tower
ATFCM	air traffic flow and capacity management
ATIS	Automatic Terminal Information Service
ATM	air traffic management
AVOL	aerodrome visibility operational level
BADA	base of aircraft data
CADEO	Controller Assistance for Departure Optimization
CADRS	combined arrival/departure runway scheduling
CFMU	central flow management unit
ConOps	concept of operations
CTOT	calculated take-off time
DFS	German Air Navigation Service Provider - Deutsche Flugsicherung GmbH
DLR	German Aerospace Center - Deutsches Zentrum fuer Luft-und Raumfahrt
DMAN	Departure Management System
ETT	earliest takeoff time
FAA	Federal Aviation Administration
FAF	final approach fix
FFBD	functional flow block diagram
ICAO	International Civil Aviation Organization
IFR	Instrument flight rules

NAS	National Airspace System
NASA	National Aeronautics and Space Administration
NMOC	Network Management Operations Center
RCM	runway configuration management
RNAV	area navigation
ROA	route optimization algorithm
RTA	required time of arrival
SESAR	Single European Sky ATM Research Program
SID	standard instrument departure
SMAN	Surface Management System
SORM	System-Oriented Runway Management
STAR	standard terminal arrival route
TLDT	target landing times
TOA	time optimization algorithm
TOBT	target off-block time
TRACC	Taxi Routing of Aircraft: Creation and Controlling
TRACON	Terminal Radar Approach Control
TRCM	tactical runway configuration management
TSAT	target start-up approval time
TTOT	target take-off time
TWR	Air Traffic Control Tower
VFR	visual flight rules
VTT	variable taxi times

References

- [1] Okuniek, N., Schaper, M., Christoffels, L., Lohr, G., Phojanamongkolkij, N., and Latorella, K., Conceptual Approach for an Integrated Capability of Arrival/Departure/Surface Management with Tactical Runway Management, internal report, March 14, 2014.
- [2] Hasevoets, N., P. Conroy, Arrival Manager - Implementation GUIDELINES and Lessons Learned, <http://www.eurocontrol.int/sites/default/files/content/documents/nm/fasti-aman-guidelines-2010.pdf> [last access: 2013/06/10].
- [3] Tuinstra, E., K. Haschke, Generic Operational Concept for Pre-departure Runway Sequence Planning and Accurate Take-Off Performance-Enabled by DMAN interaction with Airport CDM and A-SMGCS concepts, EUROCONTROL HQ, Brussels, 2009.

- [4] SESAR consortium, The ATM Target Concept D3, 2007, <http://www.sesarju.eu/news-press/documents/d3-atm-target-concept--424> [last access: 2013/03/26].
- [5] Helmke, H., R. Hann, M. Uebbing-Rumke, D. Müller, D. Wittkowski, Time-Based Arrival Management for Dual Threshold Operation and Continuous Descent Approaches, 8th ATM Seminar, Napa, USA, 2009.
- [6] Schaper, M., CADEO Controller Assistance for Departure Optimisation - a brief introduction, 2010.
- [7] Gerdes, I., Taxi routing for aircraft: Creation and Controlling - Ground Movements with time constraints, 2nd SESAR Innovation Days, November 27th – 29th, Braunschweig, Germany, 2012.
- [8] Lohr, Gary, S. Atkins, "System Oriented Runway Management Concept of Operations," NASA TM/0000-000000 (in review), 2014.
- [9] Atkins, S., Toward System Oriented Runway Management, 29th Digital Avionics Systems Conference, October 3rd - 7th, Salt Lake, USA, 2010.
- [10] Deutsche Flugsicherung, Regulation of the Implementation of Air Traffic Control (Ger. Betriebsanweisung Flugverkehrskontrolle), Air Traffic Flow and Capacity Management, Langen, Germany, 2014.
- [11] U.S. Department of Transportation, Federal Aviation Administration, Air Traffic Organization Policy, Order JO 7110.65, April 3, 2014.
- [12] Deutsche Flugsicherung GmbH (DFS), "Working in the control tower", online available on: https://www.dfs.de/dfs_homepage/en/Air%20navigation%20services/Control%20centre%20and%20tower/Working%20in%20the%20control%20tower/ [last access: 2014-10-27]
- [13] Klußmann, N., A. Malik, Lexikon der Luftfahrt (engl. Encyclopedia of Aeronautics), Springer, 3rd edition, 2012.
- [14] Deutsche Flugsicherung GmbH (DFS), German Aeronautical Information Publication, Enroute Part (ENR 1.5), Langen, Germany, 2013.
- [15] Helmke, H., H. Ehr, M. Kleinert, F. Faubel, D. Klakow, Increased Acceptance of Controller Assistance by Automatic Speech Recognition, 8th ATM Seminar, Chicago, 2013.

REPORT DOCUMENTATION PAGE

*Form Approved
OMB No. 0704-0188*

The public reporting burden for this collection of information is estimated to average 1 hour per response, including the time for reviewing instructions, searching existing data sources, gathering and maintaining the data needed, and completing and reviewing the collection of information. Send comments regarding this burden estimate or any other aspect of this collection of information, including suggestions for reducing this burden, to Department of Defense, Washington Headquarters Services, Directorate for Information Operations and Reports (0704-0188), 1215 Jefferson Davis Highway, Suite 1204, Arlington, VA 22202-4302. Respondents should be aware that notwithstanding any other provision of law, no person shall be subject to any penalty for failing to comply with a collection of information if it does not display a currently valid OMB control number.
PLEASE DO NOT RETURN YOUR FORM TO THE ABOVE ADDRESS.

1. REPORT DATE (DD-MM-YYYY) 01-11-2014		2. REPORT TYPE Technical Memorandum		3. DATES COVERED (From - To)	
4. TITLE AND SUBTITLE Functional Analysis for an Integrated Capability of Arrival/Departure/Surface Management with Tactical Runway Management				5a. CONTRACT NUMBER	
				5b. GRANT NUMBER	
				5c. PROGRAM ELEMENT NUMBER	
6. AUTHOR(S) Phojanamongkolkij Nipa; Okuniek, Nikolai; Lohr, Gary W.; Schaper, Melin; Lothar, Christoffels; Latorella, Kara A.				5d. PROJECT NUMBER	
				5e. TASK NUMBER	
				5f. WORK UNIT NUMBER	
7. PERFORMING ORGANIZATION NAME(S) AND ADDRESS(ES) NASA Langley Research Center Hampton, VA 23681-2199				8. PERFORMING ORGANIZATION REPORT NUMBER L-20466	
9. SPONSORING/MONITORING AGENCY NAME(S) AND ADDRESS(ES) National Aeronautics and Space Administration Washington, DC 20546-0001				10. SPONSOR/MONITOR'S ACRONYM(S) NASA	
				11. SPONSOR/MONITOR'S REPORT NUMBER(S) NASA/TM-2014-218553	
12. DISTRIBUTION/AVAILABILITY STATEMENT Unclassified - Unlimited Subject Category 66 Availability: NASA CASI (443) 757-5802					
13. SUPPLEMENTARY NOTES					
14. ABSTRACT The runway is a critical resource of any air transport system. It is used for arrivals, departures, and for taxiing aircraft and is universally acknowledged as a constraining factor to capacity for both surface and airspace operations. Both the German Aerospace Center (DLR) and NASA have developed concepts and tools to improve atomic aspects of coordinated arrival/departure/surface management operations and runway configuration management. In December 2012, NASA entered into a Collaborative Agreement with DLR. Four collaborative work areas were identified, one of which is called "Runway Management." As part of collaborative research in the "Runway Management" area, the goal is to develop an integrated system comprised of the three DLR tools (arrival, departure, and surface management) and NASA's tactical runway configuration management tool. To achieve this goal, it is critical to prepare a concept of operations (ConOps) detailing how the NASA runway management and DLR arrival, departure, and surface management tools will function together to the benefit of each. To assist with the preparation of the ConOps, the integrated NASA and DLR tools are assessed through a functional analysis method described in this report. Future efforts to fully develop the ConOps are also provided.					
15. SUBJECT TERMS Arrival management; Departure management; Runway management; Surface management					
16. SECURITY CLASSIFICATION OF:			17. LIMITATION OF ABSTRACT	18. NUMBER OF PAGES	19a. NAME OF RESPONSIBLE PERSON
a. REPORT	b. ABSTRACT	c. THIS PAGE			STI Help Desk (email: help@sti.nasa.gov)
U	U	U	UU	47	19b. TELEPHONE NUMBER (Include area code) (443) 757-5802