

**NASA/TP–2014-217518**



**Mobilization Protocols for Hybrid Sensors for Environmental AOP  
Sampling (HySEAS) Observations**

*Stanford B. Hooker*

National Aeronautics and  
Space Administration

**Goddard Space Flight Center  
Greenbelt, Maryland 20771**

---

**April 2014**

## NASA STI Program ... in Profile

Since its founding, NASA has been dedicated to the advancement of aeronautics and space science. The NASA scientific and technical information (STI) program plays a key part in helping NASA maintain this important role.

The NASA STI program operates under the auspices of the Agency Chief Information Officer. It collects, organizes, provides for archiving, and disseminates NASA's STI. The NASA STI program provides access to the NASA Aeronautics and Space Database and its public interface, the NASA Technical Report Server, thus providing one of the largest collections of aeronautical and space science STI in the world. Results are published in both non-NASA channels and by NASA in the NASA STI Report Series, which includes the following report types:

- **TECHNICAL PUBLICATION.** Reports of completed research or a major significant phase of research that present the results of NASA Programs and include extensive data or theoretical analysis. Includes compilations of significant scientific and technical data and information deemed to be of continuing reference value. NASA counterpart of peer-reviewed formal professional papers but has less stringent limitations on manuscript length and extent of graphic presentations.
- **TECHNICAL MEMORANDUM.** Scientific and technical findings that are preliminary or of specialized interest, e.g., quick release reports, working papers, and bibliographies that contain minimal annotation. Does not contain extensive analysis.
- **CONTRACTOR REPORT.** Scientific and technical findings by NASA-sponsored contractors and grantees.
- **CONFERENCE PUBLICATION.** Collected papers from scientific and technical conferences, symposia, seminars, or other meetings sponsored or co-sponsored by NASA.
- **SPECIAL PUBLICATION.** Scientific, technical, or historical information from NASA programs, projects, and missions, often concerned with subjects having substantial public interest.
- **TECHNICAL TRANSLATION.** English-language translations of foreign scientific and technical material pertinent to NASA's mission.

Specialized services also include organizing and publishing research results, distributing specialized research announcements and feeds, providing help desk and personal search support, and enabling data exchange services. For more information about the NASA STI program, see the following:

- Access the NASA STI program home page at <http://www.sti.nasa.gov>
  - E-mail your question via the Internet to [help@sti.nasa.gov](mailto:help@sti.nasa.gov)
  - Fax your question to the NASA STI Help Desk at 443-757-5803
  - Phone the NASA STI Help Desk at 443-757-5802
  - Write to:  
NASA STI Help Desk  
NASA Center for AeroSpace Information  
7115 Standard Drive  
Hanover, MD 21076-1320
-

**NASA/TP–2014-217518**



**Mobilization Protocols for Hybrid Sensors for Environmental AOP  
Sampling (HySEAS) Observations**

*Stanford B. Hooker*

*Goddard Space Flight Center, Greenbelt, Maryland*

National Aeronautics and  
Space Administration

**Goddard Space Flight Center  
Greenbelt, Maryland 20771**

---

**April 2014**

### **Notice for Copyrighted Information**

This manuscript is a work of the United States Government authored as part of the official duties of employee(s) of the National Aeronautics and Space Administration. No copyright is claimed in the United States under Title 17, U.S. Code. All other rights are reserved by the United States Government. Any publisher accepting this manuscript for publication acknowledges that the United States Government retains a nonexclusive, irrevocable, worldwide license to prepare derivative works, publish or reproduce the published form of this manuscript, or allow others to do so, for United States Government purposes.

Trade names and trademarks are used in this report for identification only. Their usage does not constitute an official endorsement, either expressed or implied, by the National Aeronautics and Space Administration.

*Level of Review: This material has been technically reviewed by technical management.*

---

Available from:  
NASA Center for AeroSpace Information  
7115 Standard Drive  
Hanover, MD 21076-1320

National Technical Information Service  
5285 Port Royal Road  
Springfield, VA 22161 Price Code: A17

---

## ABSTRACT

The protocols presented here enable the proper mobilization of the latest-generation instruments for measuring the apparent optical properties (AOPs) of aquatic ecosystems. The protocols are designed for the Hybrid Sensors for Environmental AOP Sampling (HySEAS) class of instruments, but are applicable to the community of practice for AOP measurements. The protocols are organized into eleven sections beyond an introductory overview: a) cables and connectors, b) HySEAS instruments, c) platform preparation, d) instrument installation, e) cable installation, f) test deployment, g) test recovery, h) maintenance, i) shipping, j) storage, and k) small-boat operations. Each section concentrates on documenting how to prevent the most likely faults, remedy them should they occur, and accomplishing both with the proper application of a modest set of useful tools. Within the twelve sections, there are Socratic exercises to stimulate thought, and the answers to these exercises appear in Appendix A. Frequently asked questions (FAQs) are summarized in a separate section after the answers to the exercises in Appendix B. For practitioners unfamiliar with the nautical terms used throughout this document plus others likely encountered at sea, an abbreviated dictionary of nautical terms appears in Appendix C. An abbreviated dictionary of radiotelephone terms is presented in Appendix D. To ensure familiarity with many of the tools that are presented, Appendix E provides a description of the tools alongside a thumbnail picture. Abbreviated deployment checklists and cable diagrams are provided in Appendix F. The document concludes with an acknowledgments section, a glossary of acronyms, a definition of symbols, and a list of references.

---

## 1. INTRODUCTION

A number of international ocean color satellite sensors were designed and launched in the last two decades to support oceanographic studies and applications including the Ocean Color and Temperature Scanner (OCTS), the Sea-viewing Wide Field-of-view Sensor (SeaWiFS), two Moderate Resolution Imaging Spectroradiometer (MODIS) instruments, the Medium Resolution Imaging Spectrometer (MERIS), and the recently launched Visible and Infrared Imaging Radiometer Suite (VIIRS). All of these sensors have contributed solutions to the general problem of inverting optical measurements obtained principally in the visible (VIS) part of the spectral domain to derive concentration estimates of biogeochemical parameters, and some continue to provide coverage of the global biosphere.

The worldwide deployment of commercial off-the-shelf (COTS) radiometers has been the primary source of validation data for ocean color remote sensing data products, because they are designed to sample the dynamic range of water types involved. The SeaWiFS Bio-optical Archive and Storage System (SeaBASS) continues to provide long-term access to these data for the global community, since its inception (Hooker et al. 1994). COTS instruments have also been used for vicarious calibration (Bailey et al. 2008 and Antoine et al. 2008), which is primarily an open-ocean problem because of the need for spatial and temporal homogeneity during sampling, at a similar level of efficacy to custom hardware, e.g., the Marine Optical Buoy (MOBY) activity (Clark et al. 1997).

For the SeaWiFS Project, the first step in the process of controlling uncertainties in calibration and validation data was establishing, through community consensus,

and then publishing, the *SeaWiFS Ocean Optics Protocols* (Mueller and Austin 1992), hereafter referred to as the Protocols. The Protocols are a *work in progress* and were revised (Mueller and Austin 1995) and subsequently expanded (Mueller 2000, 2002, and 2003) by having the scientific community decide the topics to be updated. The Protocols set the requirements for all ground-truth—more properly sea-truth—observations, and although the Protocols were initially established for the SeaWiFS Project alone, follow-on ocean color missions advocated adherence to the Protocols to minimize uncertainties in sea-truth and remote sensing data products.

The central theme presented here is the incremental pursuit of more accurate field observations to ensure access to state-of-the-art advances by making the hardware, software, and information solutions commercially or publicly available. The current challenge in ocean color remote sensing is to extend the accomplishments achieved in the open ocean into much shallower coastal habitats (Hooker et al. 2007), e.g., estuaries and rivers (Antoine et al. 2013). This requirement is driven by the present focus of satellite observations, which is inexorably linked to launching new missions based on novel research topics to derive new scientific results from an expanded spectral domain—i.e., the ultraviolet (UV) to the near-infrared (NIR).

A principal objective of the procedures presented here is to prepare for the next-generation of ocean color satellites (NRC 2007 and NASA 2010)—*which will emphasize expanded spectral (UV to NIR) and dynamic (open ocean to rivers) ranges*—with the most capable COTS instruments (hardware and software) in the shortest time possible. The latter is required to ensure that the science teams

can start collecting the baseline observations needed to begin formulating and testing the myriad details associated with hypotheses, algorithms, and databases for the new, spectrally more expansive, next-generation missions. At the same time, applicability to current-generation missions must be maintained with sampling in the legacy (VIS) domain. Because of the emphasis on the near-shore environment, which is typified by shallow water depths and an optically complex vertical structure, there is the added requirement to demonstrate that the new capabilities can be validated in waters with unprecedented multi-dimensional heterogeneity (Doxaran 2012, Matsuoka et al. 2012, and Fichot et al. 2013).

As part of an emphasis on innovation in global observations of the Earth system from space, NASA has a present- and next-generation requirement to collect high-quality *in situ* data for the vicarious calibration of ocean color satellite sensors and to validate the algorithms that use the remote sensing data. For ocean color, the physical measurement is the spectral radiance emerging from the ocean, the so-called water-leaving radiance,  $L_W(\lambda)$ , where  $\lambda$  denotes wavelength (Hooker and Esaias 1993). “High quality” refers to *measurements with a documented uncertainty to within established metrics for producing climate data records (CDRs)*. Derivations of  $L_W(\lambda)$  are routinely obtained by extrapolating near-surface in-water profiles of the upwelled radiance  $L_u(z, \lambda)$  to null depth,  $z = 0^-$ .

Contemporaneous satellite and *in situ* match-up data (usually collected to within 60–180 min in the open ocean) are required for calibration and validation activities. The applicable COTS field instruments and information systems infrastructure needed to derive and archive  $L_W(\lambda)$  data for next-generation baseline analyses include the following:

- The state-of-the-art field instrumentation, e.g., an in-water Compact-Optical Profiling System (C-OPS) or above-water Biospherical Surface and Celestial Acquisition Network (BioSCAN) with applicable accessories (<http://biospherical.com/>);
- The Ocean Optics Protocols for acquiring the field data and producing the agreed upon data products (<http://oceancolor.gsfc.nasa.gov/DOCS/>);
- A data processing scheme for producing the data products, e.g., the Processing of Radiometric Observations of Seawater using Information Technologies (PROSIT) software program (Hooker and Brown 2014); and
- An accessible repository for the original field data and subsequent processing results, e.g., SeaBASS at GSFC (<http://seabass.gsfc.nasa.gov/>).

A conceptual view of calibration and validation organizes the hardware, protocols, and processing as a triumvirate surrounding a central database (Fig. 1), so results or improvements obtained in one component can influence the other applicable component(s) and lower the risk of being unable to properly maintain uncertainties.

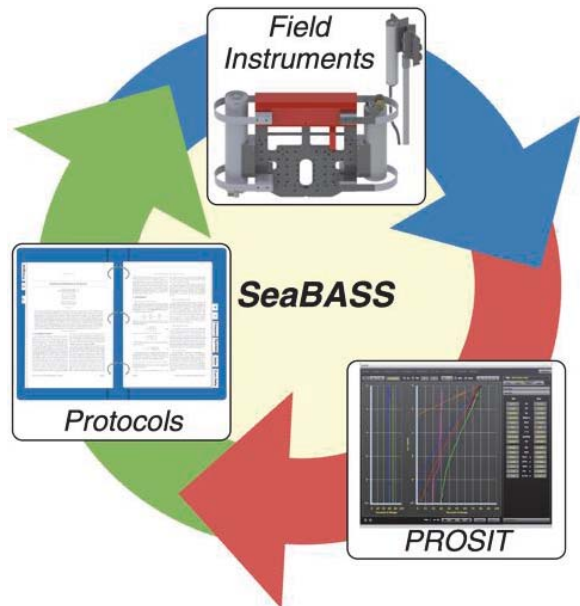

**Fig. 1.** An example information flow wherein the Protocols specify how *in situ* data are acquired with the C-OPS field instruments and then processed with PROSIT to create products to be stored with the data in SeaBASS. PROSIT tools evaluate uncertainties, which might lead to revised Protocols.

In Fig. 1, reduced risk in one component is linked to subsequent components, which in turn benefit from the reduced risk. In the iterative flow of the process, the evolving cost of the system is reduced. Each turn through the cycle is leveraged within the community as a reduced risk in decision making, and expressed in the applicable NASA programs as an overall cost benefit. The savings come from not having to acquire more data, because the quality of the data that were acquired were immediately sufficient. In this regard, risk and uncertainty go hand in hand: data with high uncertainties are inherently risky for next-generation mission planning.

The purpose of the protocols presented here is to reduce the uncertainties in sea-truth observations needed for calibrating and validating the next generation of NASA ocean color satellites by improving the community of practice and linking it directly to commercial-off-the-shelf optical instrument systems and publicly available information systems. This will allow any scientist in the world to contribute to climate change research at the requisite quality level by simply following the procedures with sensors that are available to all.

The majority of the procedures presented here are not addressed in the Protocols, so the material is seen as an important addition to developing the high-quality optical instruments plus the corresponding data acquisition, processing, and analysis protocols needed for next-generation ocean color calibration and validation. When combined with the new technologies that have been developed (Morrow et al. 2010a and Hooker et al. 2012), the procedures



are expected to ensure the new technology is ready for the global scientific community to use for legacy and next-generation climate change research. The approach adopted here is to provide—by specific example—the implicit and explicit tools, both in terms of hardware and procedures, needed by any scientist to confirm the acquired field data are at the requisite quality level.

The inspiration for the level of detail that is presented in each of the following sections was Mr. Horace Mann (4 May 1796 to 2 August 1859), who was an American education reformer and abolitionist. Horace Mann is credited with saying (as adapted in 1880),

*Habit is a cable; we weave a thread of it each day,  
and at last we cannot break it.*

This perspective was adopted because it creates the notion that sensible procedures practiced to the point of habit incrementally reinforce the metrics for success. It also creates the imagery that *the importance of a strong cable is discernible—as is its failure*. Understanding these two states is paramount to successful fieldwork. The level of detail presented here is designed to expose all the procedural “threads,” so they can be woven together over time into strong protocols.

Protocols are not infallible; they are implemented to make use of an instrument system, and system subcomponents can fail of their own accord. Consequently, a complete protocol includes procedures for troubleshooting a fault and restoring an instrument to nominal performance. The latter requires tools and, more importantly, tried and proven tools, so inventories of useful tools are also presented. Given the sophisticated designs of modern instruments, the total number of tools required to remedy all possible faults requires an impractical inventory for cost-effective field campaigns, so only the most likely problems are considered. Furthermore, the emphasis is on mobilizing on a ship, and ships frequently have a large number of tools aboard.

## 1.1 Protocols Organization

The protocols presented here are organized into eleven additional sections: a) cables and connectors, b) HySEAS instruments, c) platform preparation, d) instrument installation, e) cable installation, f) test deployment, g) test recovery, h) maintenance, i) shipping, j) storage, and k) small-boat operations. Each section concentrates on documenting how to prevent the most likely faults, remedy them should they occur, and accomplishing both with the proper application of a modest set of useful tools. The selection of what constitutes a “most likely” fault out of a large and evolving number worthy of inclusion is based on experience. Similarly, the selection of “useful tools” is also based on life experiences involving a large inventory of contemplated, accepted, and rejected hardware.

Within the twelve sections, there are Socratic exercises (i.e., questions posed to the reader) to stimulate thought,

and the answers to these exercises appear in Appendix A. FAQs from students and less experienced practitioners are summarized in a separate section after the answers to the exercises in Appendix B. For practitioners unfamiliar with the nautical terms used throughout this document plus others likely encountered at sea, an abbreviated dictionary of nautical terms appears in Appendix C. An abbreviated dictionary of radiotelephone terms is presented in Appendix D. To ensure familiarity with many of the tools that are presented, Appendix E provides a description of the tools alongside a thumbnail picture. Abbreviated deployment checklists and cable diagrams are provided in Appendix F. The document concludes with an acknowledgments section, a glossary of acronyms, a definition of symbols, and a list of references.

The choices made to create the material presented are a combination of subjective and objective analyses, which must necessarily change over time as the technology they are designed to protect change and as the tools change, either in availability or in design. Consequently, the protocols are not viewed as static and this document is one version of many that will ultimately be produced to correctly mobilize HySEAS instruments.

The procedures are applicable to both above- and in-water AOP sampling systems, but the emphasis is on the at-sea collection of in-water data, because it is the most complicated and least forgiving—a ship can decide to not leave port as severe weather approaches, but once at sea, the scientists and crews are obliged to withstand all the natural environment provides. Because this means all personnel can be placed in circumstances associated with high risk to the safety of themselves and their equipment, the material includes three levels of warning:

 Cautionary explanations to avoid a needless degradation in performance appear separately with the so-called *dangerous bend* graphic, shown to the left;

 If extra caution is warranted, because there is a significant likelihood of compromising performance, the text appears with double dangerous bends; and

 If extreme caution is required, because there is an inherent safety risk to personnel (and secondly safety of equipment) that must be respected, the text appears with triple dangerous bends.

On marine installations, safety of equipment may also contribute to safety of personnel particularly if loss of vital equipment places the ship in danger.

The cautionary notes are provided to identify procedures or aspects of the total environment—protocols, personnel, and hardware—that can lead to avoidable problems if they are misinterpreted or not adhered to. All cautions should be read carefully; adherence to the provided instructions will ensure the safety of personnel and



**Fig. 2.** The two end members in platform sizes showing **a)** the ocean-class R/V *Hakuho Maru* (left), with the height of a person standing on the bow setting the scale, and **b)** the small inflatable boat R/V *Recon 18* (right). The former displaces almost 4,000 tons with an overall length of 100 m and two 1,085 kW generators developing 2,910 hp for propulsion, whereas the latter is a FC 470 military 4.7 m Zodiac fitted with a 30 hp Nissan outboard and custom-equipped for instrument deployments including 12 VDC and 120 VAC power.

equipment. In some cases, mitigation strategies for the identified problem might be possible, but others are simply restrictions that cannot be easily overcome and should not be circumvented.

As an aid to the student and first-time practitioner, Socratic learning exercises are provided throughout the ensuing individual sections. The exercises are designed to reinforce important aspects of the protocols by providing additional details in the answers (Appendix A) to logical questions. They are also designed to establish an inquiring perspective and encourage research, and are identified by the following sequence:

► **Exercise**

which is followed by the section number associated with the material being considered.

Although above-water systems can be deployed on land to make atmospheric or terrestrial observations, the perspective adopted here is for oceanic data collection. This does not result in any loss in applicability, because the ship-based perspective shares common features with land and offshore structures, for example, all require location or global positioning system (GPS) information. At-sea deployments require additional considerations, however, because of the harshness of the marine environment and the fact that a ship is in motion. Consequently, the unique aspects of the oceanographic sampling problem can be ignored if they are not relevant to an alternative structure that is being used.

► **Exercise 1.1** *What is likely the most significant advantage and disadvantage of deploying an autonomous radiometric system on a terrestrial structure as opposed to an offshore structure or research vessel (R/V)?*

## 1.2 Platforms

Five types of at-sea deployments are considered here based on arbitrary, but sensibly constrained, sizes of a wide

range in possible deployment platforms. This approach produces five classifications for the platforms:

- Global- and ocean-class ships (55–90 m or more),
- Regional- and local-class research vessels (20–54 m),
- Coastal (small craft) research vessels (7–19 m),
- Small-boat operations (less than 7 m), and
- Shoreline or shallow-water fixed structures, e.g., a pier, dock, lighthouse, tower, etc.

These five platform options establish three general cabling needs: long (55–90 m ships), medium (8–20 m research vessels and fixed structures), and short (small-boat and shoreline operations). Mobilization protocols for this large range in vessel size (Fig. 2), are virtually the same as given below.

► **Exercise 1.2** *What types of in-water platforms are not mentioned in the five platform classifications that might benefit from mobilization protocols?*

## 1.3 Deployment Options

There are four generalized deployment options for in-water AOP sensors: a) free-fall profilers, b) winch and crane frames, c) buoys (moored or drifting), and d) autonomous vehicles (e.g., gliders). Of these, the emphasis here is on free-fall systems, because next-generation sampling requires shallow-water systems deployed from small vessels, which is most effectively accomplished with a free-fall profiler, e.g., a C-OPS instrument.

► **Exercise 1.3** *What are additional advantages of a free-fall profiler like C-OPS over the following deployment alternatives: a) winch and crane frame, b) buoy, and c) glider?*

The C-OPS instrumentation (Morrow et al. 2010b), which is a state-of-the-art replacement for the Submersible Biospherical Optical Profiling System (SuBOPS) legacy



instrument (Hooker et al. 2010a), illustrates a COTS in-water system that can be used across the full dynamic range of next-generation observational requirements, i.e., from the open ocean to rivers and from the UV to NIR.

The two types of deployment options for above-water instruments—whether on a structure, ship, or airborne vehicle—are either manually or automatically pointed. A manual system is emphasized here, because above-water systems mounted on ships are usually manually pointed.

The BioSCAN instrument is the state-of-the-art replacement of the Biospherical Surface Ocean Reflectance System (BioSORS) legacy instrument (Hooker et al. 2010b) and is selected for describing the mobilization procedures for an above-water system, because it is state of the art and sufficiently similar to C-OPS in its basic components that a unified approach to the protocols is facilitated.

The principle deployment option discussed below is the at-sea mobilization of a C-OPS in-water instrument and an above-water BioSCAN instrument. These two instrument systems are both part of the BSI architecture for HySEAS instrumentation (Sect. 3). Although this focuses the material presented here on two types of sampling systems, the majority of the protocols presented are applicable to other similar instruments, deployment options, or platforms and, therefore, easily adapted to other mobilization scenarios.

## 1.4 Instrument Components

In terms of the categories of components, the C-OPS and BioSCAN instruments are purposely similar, and are comprised of the following five subsystems:

1. A data acquisition computer;
2. A deck box to provide power, control the instruments, receive records, transmit data, and receive commands from the data acquisition computer;
3. A solar reference, with or without the Biospherical GPS (BioGPS) or Biospherical Shadowband Accessory for Diffuse Irradiance (BioSHADE);
4. Either an in-water free-falling backplane with a hand-held *sea cable* or an above-water manually pointed frame, both with two optical sensors; and
5. The cabling that connects the first four components.

Consequently, the distinction between the two systems is with the fourth subsystem, and the two options both typically use two radiometers. In the case of the in-water profiler, an irradiance and radiance sensor pair are used; whereas for the above-water frame, two radiance radiometers are deployed.

For the purposes of keeping track of the inventory of parts involved, the sea cable for the C-OPS instrument is considered part of the backplane subsystem, because it is specially made with a prescribed buoyancy and custom wire-gauge specifications. It is coiled into a cable bucket to keep it organized and safe from ship operations. The bucket shields the cable from side impacts and can be moved to a sheltered location if necessary.

 *It is not advisable to use a different sea cable than the one provided by the manufacturer, because the backplane free-fall characteristics can be negatively altered, which can lead to degraded in-water data products.*

The cabling that is used for all other connections can be obtained from a variety of sources (e.g., directly from SubConn) as long as the wire gauge and connector specifications are correct. The subsequent sections discuss the protocols associated with the successful mobilization of each aspect of cables and connectors.

► **Exercise 1.4** *What types of deployment might logically require a different type of cable for the surface reference than the one provided?*

## 2. CABLES AND CONNECTORS

For the discussion presented here, the principal purpose of an electrical cable and connector assembly is to provide a safe and reliable connection for power and data telemetry between two components. The choice of connector type and cable, i.e., the number of conductors and their specification plus the outer jacketing enclosing all wires, is an important aspect of maintaining the capabilities of a sampling system over the short and long term.

For cable assemblies that provide more functionality than power and telemetry alone, e.g., that are used to deploy and recover an instrument like C-OPS, there are the following additional requirements: a) one or more strength members to accommodate the anticipated tensile forces created when the instrument is pulled back to the surface or deployment platform and recovered, and b) material specifications to set the overall buoyancy of the cable.

► **Exercise 2.0** *What is a principal concern for an electrical cable that is designed to be used to deploy and recover an instrument system?*

Fieldwork is frequently stressful, and most mistakes occur when personnel are distracted (e.g., by an unanticipated problem, sleep deprived from travel or work, lack of familiarity with the workplace, etc.). A sampling system that is designed with components and procedures to facilitate correct installation regardless of the circumstances has a significant advantage over one that can be easily misconstrued and assembled incorrectly—especially for the new practitioner.

As noted earlier, a principle behind the protocols presented here is that safety, both for the personnel and the equipment, is a primary concern. In some cases, there are competing requirements for safety, and the adopted procedure might seem arbitrary, but that is not the case. In fact, a comprehensive point of view has been applied to all of the protocols presented here and tested over many years of fieldwork spanning thousands of hours in the field and thousands of successful data acquisition events.

 The perspective adopted here is that all cable connects and disconnects should be done with the power off, because fieldwork—most notably an oceanographic expedition—involves the high probability of working with wet components, as well as wet hands or feet, which can result in unintended and potentially hazardous electrical pathways that might go unnoticed.

It might seem possible that the direct current (DC) levels associated with modern instrument connections cannot produce hazardous electric shocks to personnel and only alternating current (AC) sources are of concern. Personnel might also believe the only concern for DC current is if power is accidentally applied to the wrong pin or socket on an instrument—which could damage the instrumentation. If the integrity of the cables and connectors have been compromised or if their integrity is unknown, this is ill advised and dangerous in all circumstances.

 If a cable or connector appears worn or physically damaged—e.g., the outer insulation has been cut or the body containing the pins or sockets has been crushed—it should not be used and should be replaced with a fully functional spare.

If cable damage is topical and restricted in extent to the consequences of *normal use*, e.g., fraying of the outer jacket over a small area (Fig. 3), with no evidence that the insulation integrity has been compromised, the frayed jacket should be wrapped with a brightly colored vinyl electrical tape to call attention to the area being protected. At some point, normal use gives way to *worn out* and a cable must be replaced. By inspecting and rectifying normal wear, a cable lasts longer and it will be visually apparent (from the accumulation of brightly colored wraps) when a cable needs to be evaluated for replacement.

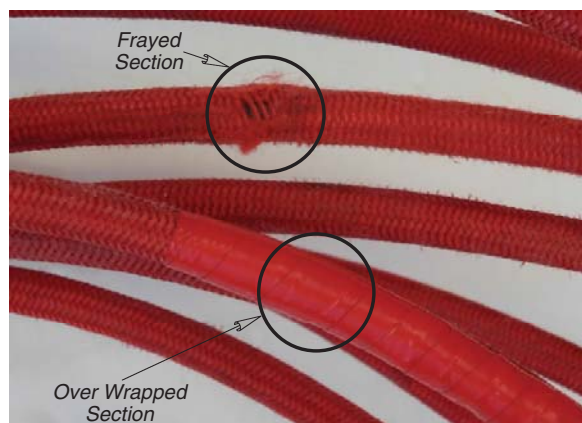

**Fig. 3.** An example of a small cable section where the outer jacket is frayed and needs over wrapping with brightly colored vinyl electrical tape as was done below, but does not need to be removed from service and replaced, because the underlying insulating jacket has not been compromised.

## 2.1 Electrical Grounding

In an electrical circuit, *ground* refers to the following: a) the reference point from which other voltages are measured; b) a common return path for electric current; or c) a direct physical connection to the Earth. For mobilization applications, the latter two are the most applicable and involve *equipment grounding* and *earth grounding*. Equipment grounding ensures the operating equipment within a structure has an unbroken connection to the Earth. Earth grounding is the intentional and physical connection from a circuit conductor, usually the neutral (or *return*), to an electrode placed in the earth or a ship's hull. When this connection is absent, the circuit has a *floating ground*.

Equipment and grounding systems must be kept separate except for a physical connection between the two systems, usually at the point of power distribution. The purpose of the ground connection is to provide a safe path for the dissipation of differences in unintended voltage potentials. The voltage potentials can arise from the normal operation of equipment (e.g., electromagnetic and radio frequency interference), fault conditions (e.g., wiring mishaps that accidentally cross wires), or natural phenomena (e.g., static discharges and lightning strikes). The safe dissipation of unintentional voltage potential protects the people and equipment in contact with the voltage potentials.

For measurement purposes, the Earth serves (essentially) as a zero potential reference against which other potentials can be measured. Consequently, an electrical ground system should have an appropriate current-carrying capability to serve as an adequate zero-voltage reference level. In electronic circuit theory, a ground is usually idealized as an infinite source or sink for charge, which can absorb an unlimited amount of current without changing its potential. As such, a ground is a *path of least resistance* and ideally should have a resistance of  $0\ \Omega$ .

Because of variability in the material structure at the point of contact with the Earth, the resistance to ground is usually not zero. A single standard resistance threshold for ground resistance that is recognized by all relevant authorities does not exist. The National Fire Protection Association (NFPA) provides some guidance on this issue within the National Electrical Code (NEC) whereby if a single rod, pipe, or plate electrode has a ground resistance of  $25\ \Omega$  or less, a supplemental electrode shall not be required (NEC 2011).

 A ground resistance of  $25\ \Omega$  or less ensures the ground is significantly less than the resistance of the human body, which is on the order of 1–1,000 k $\Omega$ .

In facilities or applications involving sensitive equipment (e.g., the telecommunications industry), ground resistance is typically set at  $5\ \Omega$  or less.

The goal in ground resistance is to achieve—and to maintain over time—the lowest ground resistance value possible that makes sense economically and physically. On

a ship, where ground currents represent an opportunity for galvanic corrosion, and where degradation between conducting surfaces is inevitable, this is not always an easy objective to satisfy.

If something is *grounded*, a conducting connection—whether intentional or *accidental*—exists between an electrical circuit or equipment and the Earth, or *another conducting body that serves in place of the Earth*.



An important aspect of electrical safety is to ensure a human body does not become “another conducting body.”

Damaged cables and connectors represent an opportunity for current to *leak* between the electrically energized (or *live*) conductors to a lower voltage potential, usually the ground. The leak to ground is a *ground fault*, and the majority of marine system faults are ground faults. A ground fault occurs when the insulation between live conductors and the ground no longer maintains an effective resistance between the live conductor and ground, e.g., because the cable was damaged.

For a *grounded* system, a ground fault is removed by an automatic opening of the circuit to break the current flow. Because ground has a very low resistance, a large current can immediately flow during a ground fault, which should exceed the current specification of the circuit breaker (e.g., a fuse). The ground fault typically results from a live conductor touching equipment metal cases. Personnel safety can be jeopardized when a live conductor comes into contact with parts that an operator can touch, e.g., the equipment or the cabling.

For marine installations the ground is usually the ship’s hull and all electrical equipment metallic enclosures and cases are conductively connected to the hull. By *bonding* the equipment to the hull, a direct path is provided between the equipment and the Earth ground. A person standing on the hull is then protected against electrical shock, because the person is at the same voltage level as the Earth ground. Furthermore, the path enables the *fault current* to flow, thereby allowing any protection or detection devices to operate.

► **Exercise 2.1** *What is the definition of an ungrounded electrical system, and what are the advantages and disadvantages of such a system?*

## 2.2 Electric Shocks

The design of electrical circuits and equipment includes high attention to and preventing an electrical shock and trapping fault conditions that can cause a shock. The occurrence and severity of an electric shock is a function of many variables† including, but not limited to, the follow-

† Because of the individual circumstances of an electric shock there are no absolute parameters regarding occurrence and severity, so what is presented here is a cautious consensus based on numerous sources, e.g., Ferris et al. (2005), Parker (2009), and NEC (2011).

ing: the integrity of cables and connectors; the voltage level, type, and frequency (AC or DC); the person’s gender (man or woman) and their body mass; and individual resistance factors (e.g., wet or dry conditions). The latter is particularly important during oceanographic fieldwork, because wet skin (from sweat or water) has a reduced resistance compared to dry skin‡. Additionally, work surfaces are often wet, providing a reduced resistance from a human body to ground. These factors combine to lower the effective resistance a body presents to an exposed voltage source, allowing greater currents to flow through the body than would normally be expected.

An electric shock will occur when any source of electricity makes contact with a (human) body part such that sufficient current passes through the skin, muscles, or hair. A properly maintained cable of the type used with HySEAS instruments is not a typical hazard. The most likely reason for a hazard to occur is if the integrity of the cable is compromised and it goes unnoticed or unrepaired.

As a general guideline, for a man exposed to DC current, the quantitative effects are as follows:

- 1 mA A slight tingling sensation;
- 5 mA The perception threshold, i.e., the accepted maximum harmless current;
- 10 mA A shock with minimal loss of muscular control;
- 60 mA A painful shock with a majority loss of muscular control;
- 75 mA The “let-go threshold” (i.e., the current threshold above which a person is unable to release an electrically energized source because of involuntary muscle contractions); and
- 90 mA A painful and severe shock with difficulty breathing and almost total loss of muscular control.

The quantitative effects of DC current thresholds for a woman are about 70% of a man.

Because wet skin is more conductive than dry skin, a common sense approach to safety when working with electrical equipment is to ensure dry contact with any source of electricity.



When handling cable that is wet, it is advisable to wear gloves that keep exposed skin dry, which might require two layers of protection—one for adequate gripping of the cable worn over one that keeps the hands and arms dry.

‡ Dry skin has a resistance of about 500–1,000 k $\Omega$ , but wet skin has a resistance of approximately 1 k $\Omega$ . The resistance of cut or punctured skin can be less than 1 k $\Omega$ , because blood contains electrolytes that facilitate the conduction of electricity. If the point of contact is a metal ring worn on a wet hand, the resistance can be on the order of 100  $\Omega$ , so removing metal objects while working mitigates the likelihood of a shock.



► **Exercise 2.2** *What other common resistance factor besides water, especially seawater, is important to be aware of when working around electrical components?*

## 2.3 Pins and Sockets

A HySEAS instrument cable has two ends, and each end has a connector with a locking sleeve (or equivalent). The connector can have either male pins (MP) or female sockets (FS). The choice as to which type is used is based on safety considerations for personnel and the instrumentation.

 Best engineering practices dictate that a *male connector must not provide power*, because if the cable is dropped against a metal surface (e.g., the deck of a ship) or handled by personnel with power applied, the exposed male pins can short harming the equipment, and potentially the person doing the work.

Damage to the electronics involved includes the deck box (power source), instrument(s), and even the acquisition computer. The vulnerability of the computer is not an exaggeration, because it is not unusual for communications circuits to not use opto-isolators, which means there is usually a direct path between the deck box and the computer, if the serial connection is in place.

In comparison, a female connector can provide power, because if the cable is dropped against a metal surface with power applied, the unexposed female sockets are significantly less likely to short (one mechanism for shorting is if the connector is dropped into salt water). This is the same convention used in household wiring: the outlet on the wall, which has power applied to it, is comprised of female sockets, and the device to be powered has a cable with male pins.

There are additional safety concerns at the point in time when the male pins first engage the female sockets, which might have power applied, that must be considered.

 For some connector specifications, it is possible to energize the male pins while they are still exposed and if the person doing the work is not careful, the energized pins can be touched, which can result in shorting and electrocution. *Connectors that do not shield the male pins during connection are strictly not recommended.*

The above-mentioned vulnerability is a principle reason why the European continental standard for wall outlets uses a recessed housing for the female sockets and why British wall outlets have an on-off switch. *When mating connectors, it is important to always make sure power is off and the pins are not touched.*

Based on the safety rule of applying power to female sockets, an instrument will always have a bulkhead connector with male pins to receive power and the deck box providing the power for the instruments will always have bulkhead connectors with female sockets.

► **Exercise 2.3** *How can the cable pins and sockets be used to establish the run direction, and why is that an advantage?*

Some connectors use a mixture of pins and sockets, so the one or more male pins act like a centering device to prevent incorrect connector orientation during installation.

 *Mixed pin-socket connectors are not recommended*, because cable run direction is not readily discerned.

To maximize the likelihood of error-free mobilizations over the long term, single-gender connectors are recommended.

In some cases, an instrument might receive and send power to another device. As long as the protocol of receiving power on male pins and providing it on female sockets is followed, improper connections will not be possible. In situations where more than one device can be powered, color coding and labeling should be used to minimize incorrect connections. In addition, commonality in pin assignments (e.g., positive voltage is always provided on socket number 1 and ground is always socket number 2) should be adopted to ensure a misconnection does not result in an improper and possibly harmful application of power to the wrong mating pin number.

If different voltage levels are provided on common pins, damage can occur if the connectors and cabling are identical. Given the cost of cable, it is appealing to have one type of cable, so protective circuitry is the best solution here. Similarly, it is appealing to have one type of connector, particularly if it provides the best functionality for the requirements of cabling the instruments to be deployed.

## 2.4 Wet Pluggable

An important function of the connector is to prevent the ingress of water and dirt, which can lead to corrosion of the connector pins and sockets. There are a variety of designs that accomplish this, however, the use of a single design that is equally capable for above- and in-water applications is inherently the most attractive, because it simplifies the inventory of components.



To further simplify the use of cables, the C-OPS and BioSCAN optical instruments and accessories are designed for *straight-through* connections, i.e., pin one connects to socket one, pin two to socket two, etc. The benefit of this approach is the ability to mix and match cables, so the inventory of spares can be kept to a sensible number.

► **Exercise 2.4** *What is a perceived “disadvantage” of all cables having the same pin assignment?*



Within this framework of making connections as easy and trouble free as possible, the so-called *wet pluggable* connectors from SubConn Inc.† (Esbjerg, Denmark) are

† MacArtney Inc.—Northeast is one of the American sales offices for SubConn connectors and cable assemblies. Their contact information is 575 Washington Street, Pembroke, MA 02359, +1-781-829-4440, [www.macartney.com](http://www.macartney.com).

specified with HySEAS instruments. These connectors are designed to be plugged together underwater, so when the connectors are mated, water is removed by internal O-rings in the female sockets, and a clean dry fitting is achieved.

  *Connectors with one or more external O-rings to achieve a water-tight connection are not recommended*, because the O-rings can be easily compromised or lost—particularly if the O-ring is the face seal for the connector.

Two types of SubConn connectors are discussed here, and both are based on gold-plated brass pins and sockets within a neoprene rubber body: a) the circular series, and b) the micro series. The use of a rubber body is an important design feature, because it can absorb pressure and punishment without catastrophically failing, i.e., cracking. The rubber body also permits *hot splicing* of the connector (if the cable is made with an appropriate jacket and can withstand the temperatures involved), which produces durable cable splices with excellent water ingress protection under high pressure (i.e., water depth).

  *Connectors with a fiberglass body for the pins and sockets are not recommended*, because the fiberglass body can readily crack if the connector is dropped against a hard surface (e.g., a metal deck or accidentally compressed (e.g., struck or crushed).

The perspective adopted here is that a connector choice that automatically requires spares to be included in field deployments to overcome avoidable vulnerabilities (e.g., the likelihood of losing an O-ring) is inferior and should not be used.

The SubConn circular series was introduced in 1978 and today is the leading industrial standard in all marine-related markets. The circular series is available in three body sizes from 2–16 contacts rated at 600 V from 5–15 A. When correctly maintained, the connectors are rated to in excess of 500 underwater matings while still retaining the minimum 200 M $\Omega$  insulation resistance. The complete range of in-line and bulkhead connectors with associated locking sleeves and dummy plugs are available with special materials, cable length, and configurations.

The SubConn micro connector is a new development based on the well-proven standard circular series. The product was produced in response to an industry need for a compact, easily assembled and reliable connector for use on equipment, e.g., oceanographic sensors. In addition to the recognized underwater applications, the connectors are particularly suited to use in areas where water is used for cleaning purposes or severe vibrations may be experienced during service. The micro series is available in the same configurations as the standard circular series, i.e., in-line plugs and receptacles plus bulkheads and dummy plugs with either pins or sockets.

The SubConn micro series six-contact connector is the only connector used with the BioSCAN and C-OPS instrumentation. The connector has a contact resistance of

less than 0.01  $\Omega$ , a temperature rating of  $-4$  to  $60^{\circ}\text{C}$  ( $25$ – $140^{\circ}\text{F}$ ), a connector rating of 300 V at 3 A, and a depth rating of 700 bar (10,000 psi). The pins and sockets are gold plated for durability and high conductance.

The designations for the micro (MC) series six-contact connectors are as follows (restricted to only the components described in this document and shown in Fig. 4): a) MCIL designates the in-line connector; MCBH designates the bulkhead connector; MCBHRA designates a bulkhead connector right-angle; MCDL designates a dummy connector; and MCDLS designates a delrin locking sleeve.

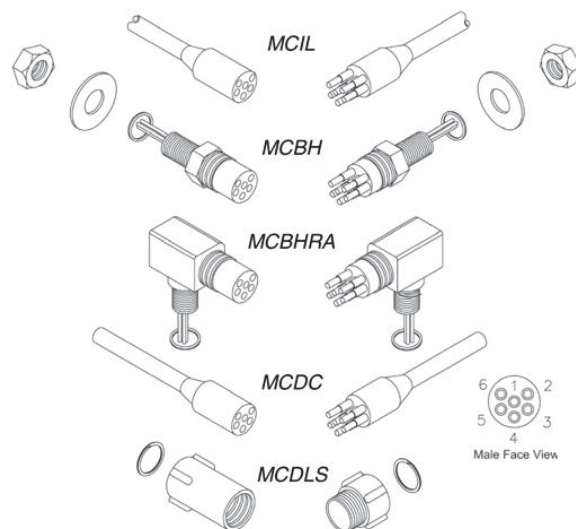



**Fig. 4.** The SubConn micro series of connectors in use with HySEAS instruments with the trade names shown between the female (left) and male (right) versions (<http://www.subconn.com>).

## 2.5 Locking Sleeves

The purpose of a locking sleeve is to tightly and mechanically join the two halves of a connector, so the connection is not easily broken by accident. A common and reliable way of achieving this tight joining is to have the two locking sleeves fasten or thread together. Threaded coupling requires one part to have exterior material removed to expose ridges, and the other to have interior material removed to expose grooves. The former is the male part and the latter is the female part.

Because of the definitions associated with threaded fasteners, locking sleeves also have a gender associated with them, and in most circumstances—but not all (Sect. 3.1)—the gender of the locking sleeve matches the gender of the connector. Consequently, an MP connector will typically have a locking sleeve with male ridges (MR), and an FS connector will have a locking sleeve with female grooves (FG).

  *Connectors with molded non-locking sleeves that can trap air in them when the connectors are mated are not recommended*, because when subsequently pressurized (e.g., submerged), the release of the air can lead to water ingress and subsequent pin corrosion or shorting.



Another reason why molded non-locking sleeves are not recommended is because the ultimate use of a cable is not always in keeping with its original specification, and the lack of a mechanical joining of the two connectors means the connection is much more easily broken by accident.

SubConn locking sleeves contain a stainless steel ring fitted into a retaining groove at the unthreaded end of the delrin plastic shell. Hereafter, a “locking sleeve” is defined as a plastic shell fitted with a steel ring. The steel ring prevents the locking sleeve from sliding past the molded connector, although an unmated locking sleeve is free to slide down the cable. The steel ring is transversely split into three connected layers (like a ring to hold keys) and can be removed by prying one end of the ring out of the groove. A simple prying tool is a miniature flat-bladed screwdriver or metal pick. Once one end is pried away from the shell, a second small screwdriver should be inserted into the gap. Driving the second screwdriver around the inside shell releases the split ring from the groove. Once released, it can be popped out over the locking sleeve shell using the miniature flat-bladed screwdriver or worked out by hand.

With the ring released, the locking sleeve shell can be slid over the molded connector and replaced. The new shell is slid over the molded connector and the split ring is worked into the mating groove. A reliable way to insert the split ring is to push it into the end hole at an angle until a little less than half the split ring is in the hole. The revealed part of the split ring is then rotated into the mating groove until an audible “click” is heard. A miniature flat-headed screwdriver or metal pick can be used to confirm all of the split ring is fitted into the groove.

The ability to change a SubConn locking sleeve in the field means an entire locking sleeve can also be replaced in the field (assuming an available spare). As discussed below, there are circumstances wherein this might be advantageous. Because alternative locking sleeves do not necessarily provide this flexibility, only SubConn connectors are discussed here.

► **Exercise 2.5** *What types of circumstances might require a locking sleeve to be replaced?*

## 2.6 Notation

The MR and FG nomenclature for locking sleeves is used here to reduce errors, because if the locking sleeves are specified as MT and FT (where “T” indicates “thread,” which is a common approach), an accidental switching of “M” for “F” (or vice versa), produces a legitimate combination of FT and MT and the error is hard to detect. If this mistake is made for the MR and FG nomenclature, however, an accidental reversal of “M” for “F” (or vice versa), produces a nonsensical combination (i.e., FR and MG), which is easy to detect.

The protocols presented here use a compact notation for referencing a connector and locking sleeve combination, wherein the connector designation (MP or FS) precedes

the locking sleeve designation (MR or FG) and the two are separated by the solidus or *division* (“/”) character. For example, MP/FG denotes a connector with male pins and a female groove locking sleeve.

► **Exercise 2.6** *What is the advantage of a cable with an MP/MR connector on one end and an FS/FG connector on the other end?*

## 2.7 Dummy Plugs

A dummy† plug is a partially functional copy of a cable connection that is used as a substitute for a normal connector, but does not have an attached cable. In other words, a dummy plug has the pins or sockets to mate with a cable connector, but no attached cable to permit the transmittance of power or telemetry.

The principle purpose of a dummy plug is to mate with a connector to protect the pins or sockets that would otherwise be exposed without the dummy plug. Although male pins are easily cleaned if fouled, female sockets can trap dirt that is difficult to dislodge, so it is particularly important to attach male dummy plugs to female connectors.

 *Dummy plugs should always be used with the appropriate locking sleeve to ensure a watertight seal, especially if the connection being protected will be immersed in water.*

 Although a compatible locking sleeve by itself provides a shield for a bulkhead connector that will not easily fall off, *the use of a locking sleeve without the mating dummy plug does not protect the connector pins or sockets from corrosion or fouling.*

► **Exercise 2.7** *For a cable with an MP/FG connector on one end and an FS/FG connector on the other end—which have locking sleeves that do not mate—what is a reliable way to protect the connectors while stowed, if dummy plugs with the appropriate locking sleeves are not available?*

## 2.8 Cable Types

There are typically four types of field cables, which are based on their intended functions, and some may be interchanged depending on the length of the vessel or size of the deployment platform:

1. Interface cables, which are designed to *directly* connect an instrument to a deck box;
2. Deployment or extension cables, which are designed to span a long distance (e.g., a sea cable) and must have an adapter cable or interface cable attached to them to connect to a deck box with mated locking sleeves;

† In English, any non-functional substitute for an object is referred to as a “dummy”, e.g., in a clothing store, a manikin is a clothes dummy.

3. Interconnect cables, which are special Y-cables designed to interconnect two sensors; and
4. Adapter cables, which are designed to convert the connector or locking sleeve from one specification to another.

The configurations discussed here for these four cable types are for the SubConn series of micro connectors and locking sleeves.

⚠ All SubConn micro connectors have a bulkhead connector with a built-in MR locking sleeve, which means the only locking sleeve that can be used on the cable that will connect to a micro bulkhead connector is an FG locking sleeve.

► **Exercise 2.8** What vulnerability is created when an extension cable is connected to a deck box?

Interface cables have a medium (15–25 m) length and are typically attached to either the solar reference instrument or the end of the main deployment cable (i.e., sea cable for a free-fall profiler). Interface cables take the brunt of the abuse aboard the deployment platform, so they are *sacrificial*, and are the less expensive to replace over time than deployment cables. The cable gender and locking sleeve arrangement for an interface cable is FS/FG at the instrument and MP/FG at the opposite (deck box) end.

Primary deployment cables are longest in length (up to 350 m) and are used as either above-water extension cables or as in-water sea cables. Extension cables are designed to be joined together to form an even longer cable, if necessary, whereas a sea cable cannot be joined together for the in-water part (because the cable might separate at the joint if pulled on strongly, which is possible) and must be at the desired in-water length to begin with. A sea cable is nonetheless considered an extension cable, because its connector and locking sleeve arrangement is the same as an extension cable to allow a *sacrificial* interface cable to be connected to it. The cable gender and locking sleeve arrangement for an extension cable is FS/FG at the instrument end and MP/MR at the opposite (ultimately, deck box) end.

Interconnect cables are short (about 1 m) and are used to interconnect two sensors to a cable from the deck box. The cable has three connectors arranged in a “Y” configuration and is also called a Y-cable. One end is the MP/MR connector that ultimately connects to the deck box, and the other two ends each have a FS/FG connector to connect to two instruments. This configuration means an interconnect cable is a special kind of extension cable and, thus, will always require at least one more cable to connect it to a deck box.

Adapter cables are typically 1 m (or less) in length. The main purpose of an adapter cable is to convert the gender of a cable or locking sleeve. For the instruments presented in these protocols, the cable gender and locking sleeve combinations are FS/FG (at the instrument connection end)

and MP/FG (at the deck box end), which is the same as an interface cable. The use of an adapter cable allows all other cables to be mixed and/or matched without the need to change locking sleeves.

There is also the concept of so-called *laboratory* or *system* cables, which allow the instruments to be powered up in a laboratory (e.g., a calibration facility) as a self-contained system. A laboratory or system cable is in fact an interface or adapter cable of a length suitable for working in a smaller space (e.g., usually 5–10 m). Because they are used indoors, it might seem attractive to specify a less durable and costly outer jacket for laboratory cables.

⚠ Laboratory cables are useful to have in the field to confirm a fault condition that is occurring with an instrument is not due to the cabling being used, so it is not advisable to purchase them without a durable outer jacket.

A summary of the four cable types discussed here and their corresponding connectors and lengths are as follows:

1. An interface cable has a medium length (usually 15–25 m) with one MP/FG and one FS/FG connector;
2. A deployment or extension cable has a long length (usually 25–50 m for an above-water system and 125–350 m for an in-water system) with one MP/MR and one FS/FG connector;
3. An interconnect or Y-cable has a short length (approximately 1 m) with one MP/MR connector and two FS/FG connectors;
4. An adapter cable has a short length (usually 1 m or less) with one MP/FG and one FS/FG connector; and
5. A laboratory cable has a medium length (usually 5–10 m) with one MP/FG and one FS/FG connector, and is further distinguished by not being routinely used in the field except to determine if a fault condition is due to a malfunctioning field cable.

Note that the lengths are simply recommendations and should be changed to match the scientific sampling objectives if necessary.

Considering all cable types except an interconnect cable, which is a Y-cable with a specialized purpose, all four remaining cable types have point-to-point purposes that can be changed. For example, an extension cable can be changed to an interface cable, by simply switching the MR locking sleeve used with the MP connector to a FG locking sleeve.

For an extension or sea cable, which have MP/MR and FS/FG connectors, the cable connectors can be protected when the cable is being stowed by simply connecting the two ends of the cable and tightening the locking sleeves. This is particularly easy to achieve with the sea cable, because the cable is coiled into the cable bucket with the MP/MR connector lying outside the bucket and the FS/FG end lying on top of the cable coil (Sect. 6.2.3).

## 2.9 Connection and Disconnection

Before attempting to mate two connectors, particularly if the cabling is unfamiliar, but anticipated to be of use to the mobilization activity, some cautions are appropriate.

 *Inspect both cables and confirm the locking sleeves and connectors are all manufactured by SubConn.*

 *Do not mix connectors and locking sleeves from different manufacturers, and do not attempt to mate them, because pin and socket tolerances, as well as sealing geometries, are sufficiently different that this can lead to damage and connector failure.*

 *SubConn locking sleeves have a steel ring to prevent the molded part of the connector from pulling through the locking sleeve, whereas some alternatives are all plastic and the molded connector and cable can be pulled through the locking sleeves.*

The problem identified with plastic locking sleeves can be aggravated by differential temperature coefficients of the connector and the mismatched locking sleeves. For example, for a cable pulled up from the colder depth of the water column to warmer surface waters, the interior connector can have shrunk more than the outer locking sleeve, and the cable and connector can be pulled through the locking sleeve. If unintended tension is then applied, the connection can part.

► **Exercise 2.9** *What is another disadvantage of an all-plastic locking sleeves?*

### 2.9.1 First Use

Many connectors require a sparing application of an appropriate lubricant before the connector is first mated. The lubricant ensures the male pins engage the female sockets without stressing the sockets and splaying them.

 *SubConn connectors, including dummy plugs, must not be mated dry, because this can lead to a failure in the rubber lamination of the connection pins and subsequent connector failure.*

To grease the connectors for the first time, apply a sparing amount of grease on the finger and wipe evenly across the female sockets. Over time, the connectors should be inspected for reapplication of the lubricant.

 *The use of too much lubrication should be avoided, because it can negatively effect connection integrity and cause the male pins to *piston* out of the female sockets.*

In normal circumstances for connections not made underwater, the expulsion of excess grease can be heard as it is squeezed out of the connectors when they are mated. If this occurs, or if excess grease is visible around the periphery of where the connectors mate, wipe the excess away with a disposable paper towel, and carefully repeat the mating and wiping process until a smooth and even connection is achieved.

► **Exercise 2.9.1** *What is another reason to not use excessive grease when lubricating a connector?*

### 2.9.2 Connection Protocol

A proven connection protocol for SubConn cables that have already been brought into service (Sect. 2.9.1), is as follows:

1. Remove any dummy plugs by unscrewing the locking sleeves following the disconnection protocol (Sect. 2.9.3), and stow them appropriately (Sect. 6.1).
2. Inspect the connectors and confirm they are clean. If present, dirt or debris in the female sockets should be removed with freshwater; failure to do so could result in the splaying of the female sockets and damage to the internal O-ring seals.
3. Inspect the connectors for proper lubrication<sup>†</sup>. If necessary, apply a sparing amount of grease on the finger and wipe evenly across the female sockets, which should result in the deposition of a small mount of grease in each socket hole. If upon inspection any socket holes do not contain grease, a small amount should be applied.
4. Orient the connectors for proper pin-to-socket alignment (i.e., pin one aligns to socket one, pin two to socket two, etc.); for a symmetrical number of pins and sockets, a centering pin is usually provided as part of the male connector to facilitate proper alignment, but for the six-conductor connectors used with HySEAS instrument, the pins are arranged in an asymmetric pattern (Fig. 4).
5. Mate the connectors by gripping the rubber body containing the pins or sockets, avoid sharp bends in the cabling which can interfere with a smooth alignment of the connectors and needlessly strain the conductors, and then push the male pins into the female sockets. Visually verify the connectors have *bottomed out* or are at their *full-extent* position.
6. Mate the two locking sleeves and tighten them.

Two common mistakes by first-time or novice practitioners are a) not verifying that the connectors are lubricated, and b) applying excessive grease to lubricate new connector pins and sockets.

 *Failure to adhere to a connection and disconnection protocol can result in the completely avoidable loss of connection integrity in the short term, and premature connector or cable failure in the long term.*

<sup>†</sup> SubConn recommends Dow Corning Molykote 44 medium grease, although Dow Corning 111 grease has been shown to be extremely effective over more than a decade of use in the field. Both products are silicone oil compositions.

► **Exercise 2.9.2** What is an “appropriate” procedure to stow dummy plugs?

### 2.9.3 Disconnection Protocol

A proven disconnection protocol for SubConn cables that have already been brought into service (Sect. 2.9.1), is as follows:

1. To disconnect mated connectors, loosen the locking sleeves, grip the rubber body containing the pins or sockets, and pull straight apart. *Do not pull at an angle and do not pull on the cable or the dummy plug short extension.* Pulling at an angle or pulling on the cable can unduly strain the integrity of the physical bond between the wire leads and the sockets or pins.
2. If the disconnect will persist for a long time, connect the appropriate dummy plug with locking sleeve to each exposed connector, and tighten each locking sleeve.

► **Exercise 2.9.3** What is an appropriate way to protect exposed pins or sockets for an extended period of time if no dummy plugs are available?

## 2.10 Shielding

If a mated SubConn connector will be exposed to long-term heat or sunshine, the mated connectors and locking sleeves should be over wrapped with vinyl electrical tape (or a suitable substitute) as a shield and to slow the *baking* of the cable and locking sleeve. Long-term baking of the connectors and cable results in a *drying* effect, wherein the oils that are present are lost and carbon black is leached from the rubber. This results in discoloration, cracking, and deterioration of mechanical properties. Although a slow process, exposed components ultimately fail, frequently due to an ingress of water.

Another source of radiation which might require shielding depending on the design of the equipment being deployed, and particularly on ships which can have powerful radio transmitters, is electromagnetic radiation<sup>†</sup>. A shielded cable has the insulated conductors enclosed by a common conductive layer composed of braided strands of metal (e.g., copper or aluminum) or a layer of a conducting polymer. Usually, this shield is covered by the outer jacket layer(s) of the cable.

The shield functions as a Faraday cage to reduce the interference caused by external electromagnetic radiation sources and minimizes noise that is capacitively coupled to other electrical sources.

 To be effective, the cable shield must be applied across cable splices—that is, *the shield must be continuous across connections.*

<sup>†</sup> The optical instruments used with C-OPS and BioSCAN are completely shielded and do not require additional shielding for electromagnetic radiation.

► **Exercise 2.10** What happens to the integrity of the shield when shielded and unshielded cables are mixed together in a single cable run.

## 3. HySEAS INSTRUMENTS

The HySEAS architecture is based on sensors built with so-called *microradiometers* (Booth et al. 2010). A microradiometer consists of a photodetector (usually silicon), preamplifier with controllable gain, high resolution (24 bit) analog-to-digital converter (ADC), microprocessor, and an addressable digital port. In other words, it is a fully functional networkable sensor, all of which resides on one small, thin, printed circuit assembly (PCA) that is sleeved inside a metal cylinder for mechanical support and electromagnetic radiation shielding. With the addition of the front-end optics (collector, window, and filter stack), the basic form factor resembles a shortened pencil.

► **Exercise 3.0** How does the fact that a microradiometer PCA contains circuits so small it must be machine made affect quality?

The microradiometer design was developed in response to a need for smaller, faster, and potentially less expensive radiometers, which could be easily scaled to either more or fewer channels and more easily deployed in coastal waters. Because each microradiometer channel has an individual ADC, no multiplexer is required, and no cabling is needed, thereby eliminating a source of electronic leakage and improving reliability. The photodiode current is converted to voltage with an electrometer amplifier with three gain settings, and the resulting voltage is directly fed to the ADC. The entire assembly, including the photodetector, is located on a single circuit board measuring  $0.35 \times 3.0$  in<sup>2</sup> ( $0.9 \times 7.6$  cm<sup>2</sup>).

Each microradiometer is also equipped with a temperature sensor located close to the photodetector. Clusters of microradiometers (usually 13 or 19) can be matched with front-end optics to form small, fast, less expensive, multiwavelength radiometers for a variety of measurements. Each cluster is managed by an aggregator that allows the array of individual radiometers, plus any ancillary sensors, to function as a solitary device. Clusters of microradiometers are used to build a variety of sensor classes (Morrow et al. 2010c), but the relevant class here is the Expandable Technologies for Radiometric Applications (XTRA) class, which is used to build C-OPS and BioSCAN instruments.

Microradiometers allow XTRA sensors to have a small form factor, large dynamic range (10 decades), and high spectral resolution, which permits two or more design elements to work together in a hybrid configuration to improve the quality of the acquired data and the resulting data products. The hybrid features of C-OPS and BioSCAN instruments are described below (Sects. 3.1–3.3).

Although C-OPS and BioSCAN support a diversity of configurations, both systems usually measure the spectral



global irradiance as a function of time ( $t$ ) during data acquisition,  $E_d(0^+, \lambda, t)$ , where  $z = 0^+$  denotes just above the sea surface. Both systems use two additional sensors to make simultaneous measurements of the in-water water column (C-OPS) or the above-water sea surface and one or more celestial targets (BioSCAN). For C-OPS, the downward irradiance,  $E_d$ , is measured along with either the upward irradiance,  $E_u$ , or  $L_u$ . For BioSCAN, the (indirect) sky radiance,  $L_i$ , is measured with the total radiance at the sea surface,  $L_T$ . Each measurement system uses three radiometers.

Within a C-OPS or BioSCAN instrument system, the spectral measurements from all sensors are made simultaneously (to within 8 ms) and at the same nominal wavelengths (typically to within 1 nm). Time is used to match the observations to one another. The subsequent sections explain the instruments in more detail, and how to select their deployment locations.

### 3.1 Solar Reference Measurements

High-quality BioSCAN and C-OPS measurements require solar reference observations, which are recorded simultaneously with the two respective above- and in-water radiometers. As long as the solar observations are constant or slowly changing, they are used to correct the other measurements for changes in the solar illumination. Even if atmospheric conditions are stable, changes in the solar zenith angle usually necessitate this correction.

Solar reference observations,  $E_d(0^+, \lambda, t)$ , are required for the following:

- To confirm the solar illumination is stable, i.e., it is constant or slowly evolving (principally by the relatively slow change in the solar zenith angle), during data acquisition;
- To capture the extent of short-term transients (e.g., a small cloud passing in front of the solar disk), so these events can be removed from all observations; and
- To correct the other light observations for changes in the solar illumination.

If the BioSHADE accessory is used, additional information regarding the atmosphere can be derived (depending on how the measurements are made and how frequently they are obtained).

► **Exercise 3.1** *How else might the solar reference be used as a “reference”?*

A minimum configuration for a solar reference is a single  $E_d(0^+, \lambda, t)$  sensor mounted on mast with unobstructed hemispheric viewing of the sky, which has been shown to be superior to floating alternatives (Hooker and Maritorena 2000). In some cases, the same mast is used for more than one solar reference, e.g., for reference intercomparisons. A solar reference can also include the BioGPS and

BioSHADE accessories, which is the typical configuration considered here for HySEAS instrumentation, as shown in Fig. 5.

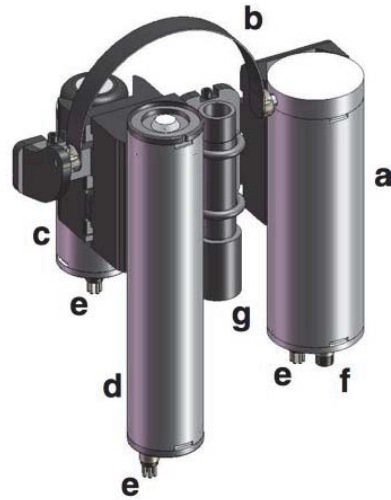

**Fig. 5.** A semi-transparent drawing of the C-OPS and BioSCAN solar reference with cables omitted for clarity and details of the irradiance sensor deferred to Sect. 3.3: **a)** BioSHADE controller; **b)** shadow band; **c)** BioGPS; **d)** irradiance sensor; **e)** bulkhead connector (receive power); **f)** bulkhead connector (supply power, 1 of 2); and **g)** 1 in 316 SS pipe with coupler. There are three bulkhead connectors on the BioSHADE controller end cap.

Although not explicitly shown in Fig. 5, a solar reference typically has two-axis vertical tilt sensors. The pitch and roll sensors are used to confirm the vertical tilting of the assembly during data acquisition, which is inevitable on a boat, is not biased. In other words, they are used to confirm that both axes of motion pass through their respective  $0^\circ$  points, which are established during mast installation by plumbing<sup>†</sup> the mast.

The BioGPS provides the geolocation of the acquired data, as well as Coordinated Universal Time (UTC<sup>‡</sup>) at 1 Hz, which is the worldwide timebase used to regulate clocks. UTC is one of several closely related successors to Greenwich Mean Time (GMT). For most general purposes, for example, logging the start and end time of campaign events like the beginning and ending of data acquisition times, UTC is synonymous with GMT.

<sup>†</sup> Plumbing a mast establishes the vertical direction of the mast that is perpendicular to a level reference, which in most cases is the localized sea surface.

<sup>‡</sup> The definition of the UTC acronym arose from a desire by the International Telecommunication Union (ITU) and the International Astronomical Union (IAU) to use the same abbreviation in all languages. English speakers originally proposed Coordinated Universal Time (CUT), while French speakers proposed *Temps Universel Coordonné* (TUC). UTC was selected as a compromise, because it contains the necessary letters and conforms to letter patterns for the variants of Universal Time (UT0, UT1, UT2, etc.).



The instruments used with BioSCAN and C-OPS are very similar. The most significant differences are the former radiance sensors have a smaller full view angle (FVA) and the latter requires unique design characteristics to function underwater (e.g., the composition of the cosine collector). The following specifications apply to the three 19-channel instruments plus BioSHADE and BioGPS accessories typically used with C-OPS, with clarifying applicable values for BioSCAN indicated in brackets (a specification that is not applicable to BioSCAN is denoted N/A):

|           |   |
|-----------|---|
| Housing   | Anodized aluminum 2.75 in (7.0 cm) diameter.  |
| Depth     | Typically 125 m [N/A].  |
| Spectrum  | Selectable from 305–875 nm [250–1,650 nm].  |
| Sampling  | 12–15 Hz.   |
| Data      | 115,200 baud (full or half duplex).   |
| Power     | 0.60 A typical at the deck box, and more than 6.0 A during battery charging.          |
| FVA       | 14.0° in water [2.5°].  |
| Cosine    | ±3% 0–60°, ±5% 60–70°, and ±10% 70–80°.   |
| Descent   | 5–60 cm s <sup>-1</sup> to within 5° two-axis tilts [N/A].                            |
| Ancillary | Water temperature [N/A],<br>Pressure transducer [N/A], and<br>Two-axis vertical tilt. |
| Thermal   | –15 to 50°C.  |

Individual wavelengths can be changed by the manufacturer, which is a straightforward exercise for instruments built with microradiometers.

### 3.2 BioSCAN Above-Water Measurements

The above-water technique that BioSCAN was designed for is an extension of the so-called Modified Fresnel Reflectance Glint Correction method (Mueller and Austin 1995) that includes a more accurate representation of the sea surface reflectance and bidirectional effects (Hooker et al. 2004) and is called the Q02 method. The Q02 approach is based on measuring the spectral global irradiance (from the sky and Sun) plus  $L_i(0^+, \lambda)$  and  $L_T(0^+, \lambda)$ . The latter is composed of the radiance leaving the sea surface from below ( $L_W$ ), the direct sunlight reflecting off the surface (the sun glint), and the indirect skylight reflecting off the surface (the sky glint).

Consequently, the typical above-water configuration for a BioSCAN frame is two separate above-water radiometers measuring  $L_T$ , and  $L_i$ , as shown in Fig. 6. For BioSCAN, the  $z = 0^+$  nomenclature is understood, and is usually omitted. All three sensors are synchronized by the deck box to make their respective measurements (nearly) simultaneously. Because the BioSCAN frame mounts the optical instruments at the desired viewing angle, usually  $\vartheta = 40^\circ$  up from nadir for  $L_T$  and  $\vartheta = 40^\circ$  down from zenith for  $L_i$ , BioSCAN radiometers typically do not have two-axis vertical tilt sensors; these data are provided by the  $E_d(0^+)$  radiometer, which has tilt sensors. In addition, because the angular geometry is fixed, it is not typically represented in the symbology, because it is an understood constant.

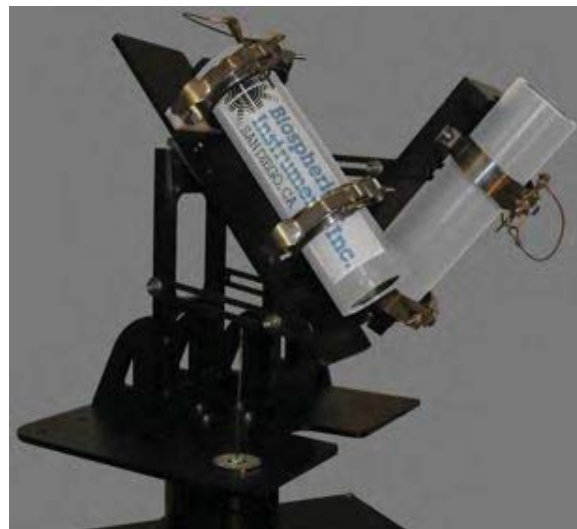

**Fig. 6.** The BioSCAN frame with the optical instruments mounted and the solar compass in the foreground.

The other variable that is important to an above-water method is the solar azimuth angle,  $\phi$ , which necessarily changes as a function of the time of day and is usually specified with respect to an arbitrary reference, e.g., due north. To avoid the sun glint in the sun plane, the BioSCAN radiometers must be pointed away from the Sun (usually 90°). An angle 90° counterclockwise (CCW) away from the Sun (viewed from above) is denoted  $\phi^-$ , and an angle 90° clockwise (CW) away from the Sun (viewed from above) is denoted  $\phi^+$ . The signs on this rotation nomenclature are arbitrary, but follow published conventions. The basic protocol that the BioSCAN frame facilitates involves the following: locating the sun plane, rotating the frame perpendicular to the sun plane to minimize sun glint contamination in the  $L_T$  measurement, and collecting observations under stable illumination conditions.

► **Exercise 3.2** Why does rotating the BioSCAN radiometers perpendicular to the sun plane not eliminate sun glint contamination in the  $L_T$  measurement?

### 3.3 C-OPS In-Water Measurements

The typical in-water configuration for a C-OPS instrument is a combination of upward- and downward-viewing sensor pairs. For example, an  $E_d(z, \lambda)$  sensor plus either a  $L_u(z, \lambda)$  or  $E_u(z, \lambda)$ , sensor. A pressure transducer and seawater temperature probe is typically included in the  $L_u$  sensor end cap. In addition, the  $E_d$  sensor usually contains a two-axis tilt sensor to determination the vertical tilt of the profiler as it descends through the water column. The solar reference and the two in-water sensors are synchronized by the deck box to make their respective measurements (nearly) simultaneously. Figure 7 shows the typical configuration for an  $L_u$  and  $E_d$  sensor pair.

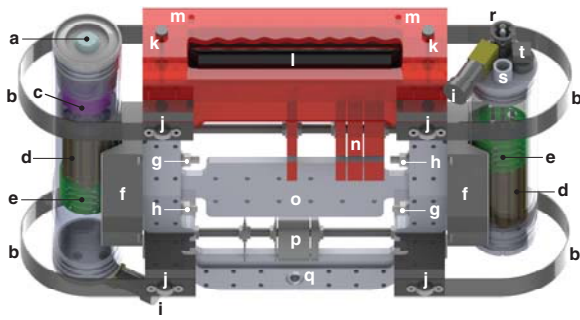

**Fig. 7.** A transparent drawing of the C-OPS in-water instrument components (the *roll* axis is the long axis and the *pitch* axis is the short axis into or out of the page) with cables and harnesses omitted for clarity: **a)** irradiance cosine collector; **b)** side-impact bumper or fender; **c)** irradiance lens; **d)** cluster of 19 microradiometers; **e)** aggregator boards; **f)** sensor v-block; **g)** pitch fixed-point nut; **h)** pitch rotation nut; **i)** dummy plug; **j)** harness attachment; **k)** knurled screw; **l)** hydrobaric buoyancy chamber revealing a black air bladder; **m)** air holes; **n)** foam flotation disks; **o)** perforated backplane; **p)** weight disks; **q)** spar fitting point; **r)** water temperature probe; **s)** pressure transducer port; and **t)** nitrogen purge fitting (one per instrument).

The C-OPS features in Fig. 7 that enhance data quality, directly or indirectly, are as follows:

- The bumpers protect the radiometers from side impacts during deployment and recovery;
- The plano-convex lens inside the irradiance sensor diffuses the light from the cosine collector uniformly across the array of microradiometer apertures below the lens;
- The aggregator and support electronics boards allow the microradiometers to be controlled as a single device with a high sampling rate (12–15 Hz);
- The sensor v-blocks are attached to the backplane at a fixed point and a rotation point;
- The *pitch* rotation nut allows an offset bias of the sensor to be set to counter cable tension or an ambient current that can pitch the instrument away from the desired vertical tilt of less than  $5^\circ$ ;
- The knurled screws hold the lid on the hydrobaric buoyancy chamber, which can contain a mix of up to three air-filled bladders and rigid foam inserts;
- The air-filled bladders slowly compress and allow the instrument to loiter near the sea surface;
- The air holes allow the hydrobaric buoyancy chamber to flood (two of four shown);
- The foam flotation disks can be moved from side to side to trim the *roll* axis to maintain a desired vertical tilt of less than  $5^\circ$  (the slotted edge is visible as the dark band below the letter “n” for clarity, but is

normally oriented downwards and then held tightly by the nuts to the left and right of the disks);

- The holes in the backplane allow for securing the cabling and the mounting of other devices;
- The adjustable weight disks, which are slotted and firmly affixed using nuts to the left and right, establish the negative buoyancy and can be moved from side to side to trim the *roll* axis; and
- The fitting point for a flexible or rigid downward-pointing spar, which if used, can provide protection against a bottom impact.

The use of a flexible or rigid downward-pointing spar can also be used to apply additional weight, which can further increase the righting response of the backplane, because it will apply a downward stabilizing force.

► **Exercise 3.3** Why is knowing the vertical orientation of the profiler during descent important?

Because of its surface loitering, slower descent, and faster acquisition capabilities, C-OPS sampling captures the high-frequency perturbations from wave-focusing effects. This means C-OPS observations minimize the aliasing normally encountered with legacy devices for this phenomenon that can significantly degrade the ability to establish the extrapolation interval in near-surface waters, particularly if the water is very clear. The high vertical resolution also means the presence of thin intrusive layers (perhaps of freshwater origin from rivers or melting ice) are properly sampled for the first time in a free-fall system.

### 3.4 Deck Box

The deck box used with BioSCAN or C-OPS is housed within a Pelican Products, Inc. (Torrance, California) type 1300 case. When the lid is closed and the latches secured, the deck box is waterproof, and can be washed down with freshwater. From the exterior, the deck box has two six-pin micro FS/MR bulkhead connectors; one provides power and telemetry for the solar reference and the other provides the same functionality for the instruments on the BioSCAN frame or the C-OPS backplane.

The interior of the deck box contains a master aggregator circuit board with support electronics, plus a sealed 12 VDC battery and charging circuitry. The master aggregator sets the sampling rates and coordinates the polling of all the attached aggregators with their microradiometer assemblies. The deck box support electronics provide microprocessor-controlled power for all the sensors and is designed to avoid instrument damage due to improper power-up sequences over varying cable lengths. The Recommended Standard 485 (RS-485) signals (or RS-422 for some instruments) from the two six-pin power-telemetry connectors are combined in the deck box and converted to RS-232 communications for computer logging.

The deck box control panel provides an on-off switch, 12 VDC power receptacle for the AC adapter, two safety

fuses, an RS-232 bulkhead and universal serial bus (USB) 2.0 connector for computer logging, indicator LEDs, and a digital display (Fig. 8). The on-off switch is of the latching type and must be unlatched by pulling up on the switch before changing the switch setting.



**Fig. 8.** The front panel of a BioSCAN or C-OPS deck box showing the power switch (slightly below and left of the green display) latched in the off position.

The two fuses, F1 and F2, on the deck box front panel protect each of the power-telemetry ports, respectively, wherein port 1 is the BioSCAN frame or the C-OPS backplane, and port 2 is the solar reference. Both fuse types are 800 mA slow blow  $5 \times 20$  mm. The RS-232 connection is a D-subminiature (D-sub) connector with an E-size (nine-socket) shell (DE-9S) and a pin assignment for communications with a personal computer (PC).

The LEDs provide the following indications:

- If the AC adapter is plugged in, the Charger Power LED is illuminated.
- If the AC adapter has been plugged in long enough, the Charge Complete LED is illuminated.
- If power is provided to the 12 VDC input, it must be 10.0–14.5 VDC, and the Power LED is illuminated.
- If the DC input voltage nominally exceeds 14.5 VDC (the exact voltage could depend upon current draw and component tolerances), the Input Overvoltage! LED is illuminated.
- If the deck box receives RS-232 serial communications, the From PC LED is illuminated and blinks rapidly.
- If the deck box sends RS-232 serial communications, the To PC LED is illuminated and blinks rapidly.

The digital display provides sequence and status information regarding the powering up of all system components (Sect. 7.2.1). The display messages establish what action is taking place (e.g., **Activating Port 1**), the response to the action (e.g., **Drawing 190.4mA**), and other pertinent information (e.g., **Stabilizing ...**). Although designed to be powered by an AC adapter that provides

12 VDC power, the deck box can also be powered from a standalone 12 VDC battery. In this configuration, a special cable is used to connect the external battery to the 12 VDC input on the deck box control panel.

The recommended battery type for externally powering a deck box is an absorbent glass mat (AGM) 12 VDC battery. AGM batteries are discussed in more detail in Sect. 12.4 (as part of small-boat operations).

► **Exercise 3.4** Are there negative consequences if the C-OPS underwater cable is accidentally connected to the reference bulkhead rather than the underwater (profiler) bulkhead on the deck box?

### 3.5 Acquisition Computer

The data acquisition environment is organized around the computer used to acquire the optical data, usually a laptop to save space in the confined areas typically found on ships. The following additional components provide a complete acquisition capability: a) a marine very high frequency (VHF) radiotelephone (R/T), plus a second one for the person conducting deck operations; b) a written log book; c) the optical system deck box; and d) an uninterruptible power supply (UPS).

The purpose of the UPS is to provide protection against a loss of power, or power dropping below the allowed minimum or exceeding the allowed maximum. On a ship, these are usually short-term events, so an extensive battery pack for the UPS is not normally necessary. In addition, both the deck box and the laptop computer have internal batteries, so the opportunity to work with no ship power is extensive, even if the UPS has a small capacity. For this reason, a UPS with a 500–700 VA capacity is recommended.



**Fig. 9.** An example acquisition computer environment aboard the TR/V *Oshoro Maru* showing the following: laptop computer (center foreground), marine radio (left of computer), written log (right of computer), C-OPS deck box (background left), and a small UPS (background right).

► **Exercise 3.5** If so much of a modern acquisition system is computerized and can easily accommodate automated record keeping, why retain a written log?



## 4. PLATFORM PREPARATION

It is an established axiom that approximately 90% of all system performance problems and failures in the field are related to cables and connectors. It is a false economy to choose inexpensive cables and connectors, if that selection compromises reliability. This is particularly true for remote deployments, either in terms of the destination (e.g., the Arctic) or the platform (e.g., a ship), because in such cases a very limited set of resources for problem solving are available. Furthermore, the cost of shipping to remote locations is frequently a significant percentage of the value of some components, so a fewer number of high-quality components are more beneficial than a larger number of low-quality alternatives.

Years of experience have revealed a number of cable and connector strategies that work together to guarantee that an instrument system will be configured correctly for deployment in almost any situation. This section describes an optimum approach for ensuring cables are correctly identified and connected, that the installation of the cables is appropriately safe and respectful (i.e., *ship-shape*), and that the risk of cable failure, perhaps resulting in a campaign ending prematurely, is sensibly minimized.

Near-shore, shallow water, or blue-water oceanographic profiling systems, as well as above-water AOP systems, will all benefit from the use of the following cabling protocol. The strategy involves procuring a number of different cables that are assigned to different tasks. In the short term, the approach may seem more than what is minimally necessary, but the incremental cost of a handful of important intermediate connections is easily offset by the cost of a system failure during an important campaign, especially when groups are dependent on sharing coincident data, which is typical for most deployments.

► **Exercise 4.0** Which is more vulnerable to failure, the cable or the connector?

### 4.1 Installation Preparation

Properly installing a solar reference along with an in-water free-falling backplane or above-water sampling frame involves the following: a) firmly attaching mounting fixtures to hold the solar reference and sampling frame, b) routing the power-telemetry cables between the instruments and the deck box, and c) installing the serial communication cable between the data acquisition computer and the deck box. The order in accomplishing these tasks can be important, especially if little time is available for mobilization and if the present platform has never been used before.

► **Exercise 4.1** What is a common mitigation factor that must be considered when assigning priorities for mobilization work?

Regardless of the prioritized order of the installation, tools are required before starting any work. Because the work plan can be separated into well-specified major tasks (e.g., mounting the sensors, installing the cable, etc.) it is most efficient if the tools for each are prepared ahead of time and put into separate color-coded or labeled bags. The separation of function and inventory also produces manageable lists of what is needed in each bag, which makes it easier to check that all necessary items are in each. Soft bags are preferred, because they pack more efficiently and do not require very much padding to fill voids. The recommended tool bags are as follows:

- Hardware tool bag for instrument installation (Sect. 5.1);
- Computer and deck box installation (Sect. 5.5);
- Tape and cable ties tool bag for cable installation (Sect. 6.1);
- Connectors tool bag for sensor and cable installation (Sect. 6.1); and
- Deployment tool bag (Sect. 7.0); and
- Maintenance tool bag (Sect. 9.1).

The above-cited task sections include inventories of the recommended tools and supplies for each bag.

### 4.2 Prioritizing the Tasks

The order in which cable installation tasks are executed can be important. Consequently, it is sensible to assume the worst and proceed accordingly, *because it might turn out that way for an unanticipated problem*. The underlying principles, which are based on the concept that a “task” is the proper execution of a mobilization activity *plus the successful application of corrective measures if the activity encounters problems*, are as follows:

- If a task can only be done while the ship is docked, do it first.
- If a task cannot be done safely at sea, do it next.
- If a task is likely to require input from the crew, do it next.
- If a task is complicated (i.e., time consuming) and there is a chance it might have to be repeated if a subsequent task is not successful or not adaptable to an unanticipated problem, do the identified subsequent task next.
- If a task is complicated and the subsequent tasks it depends on are all adaptable to change, do it next.
- If a task is easy and quick to accomplish, do it last.

This hierarchy is not foolproof for all problem sets. It has been demonstrated repeatedly to significantly improve the chance of a successful mobilization for a wide array of common and not-so-common mobilization problems, because it manages time and risk, which are interlinked.

For the aforementioned hierarchy to be useful, it is necessary to first assemble all the relevant information. This will involve individualized investigations, because each deployment is a separate set of challenges. Information gathering means accessing the possible areas that are attractive locations for the equipment, and in some cases, permission will be needed to access some of those sites.

It is always a good idea to meet with the responsible crew members, when preparing to install any instrument on a deployment platform, because some of the most important information is only available from the crew and permission might be needed for aspects of the installation.

On large and small platforms, installation discussions can involve a number of people, because of the different types of installed equipment that might be affected (Fig. 10). For example, on an ocean-class vessel, the first officer, chief engineer, radio officer, bosun, and chief (scientific) technician will likely be involved. On smaller vessels, the captain or mate are usually all that are involved.



**Fig. 10.** Cable and instrument installation discussions on board the Lucinda Jetty Coastal Observatory (LJCO) off the coast of Lucinda, Australia.

Even after all the needed information is assembled, there are still hidden vulnerabilities associated with understanding and analyzing the information. Consider, for example, the following scenario:

- A deployment is scheduled for an ocean-class ship in a foreign port with a primarily tourist economy and little access to advanced technology. Shortly before mobilization, a last-minute change in the science objectives necessitates the use of an old instrument that was not part of the original mobilization plan, but the change occurs in time for the old equipment to be included in the shipment to the foreign port.

- Shortly after arriving at the dock, an inventory of the sensors and cabling reveals a missing adapter cable for the deployment of one of the old eight-pin sensors, which cannot be used with the new six-conductor cabling for the other sensors being deployed, because in addition to a difference in the number of pins, the conductor assignments in the new cabling architecture are different than that used with the old sensor.
- The manufacturer of the sensor is notified by satellite telephone, and the missing cable is sent by overnight express delivery, but the remote location and the short mobilization time—one or more days of which are scheduled to occur at sea—means the cable arrives in the afternoon of the last full day in port.
- At this point in time all the instruments are sited and mounted, all the cabling is run, all the other sensors are tested with the installed cabling and confirmed to work properly, and the only cable that is not installed is the missing short adapter cable.

► **Exercise 4.2** What should happen next given the priority matrix?

Here is what actually happened:

1. The new cable was inspected and noted to have a non-standard assembly. It was apparent that the hand-made conductor splices were not staggered, i.e., all the splices were made at the same location along the length of the cable, which meant each splice laid against all the other splices to create a large “ball” of connections in the middle of the cable.
2. Because of the non-standard appearance of the new cable, signal integrity was checked using the pin-to-socket specifications provided with the cable. Pin one was confirmed to be connected to the correct socket, pin two was confirmed to be connected to the correct socket, and so on, until all pins were confirmed.
3. After the successful *pin-out* test, the cable was installed and power was applied to the last instrument.
4. The deck box immediately faulted (blown fuse)—and literally *smoked*—so power was turned off.
5. An inspection of the deck box revealed several burned circuits, as did an internal inspection of the sensor.
6. A postmortem investigation of the adapter cable revealed one of the data-telemetry conductors shorted to the power conductor, because a sharp solder edge in one was pressed up against the other and punctured the protective heat shrink tubing.
7. The ship sailed shortly after the postmortem. Over the next two and a half days, the burned circuits were repaired with spare electronics available on board (spare inductors were unavailable, so some repairs were completed with resistors).



In the end, one full station of data was lost, which is painful for any cruise, but not catastrophic for an ocean-crossing expedition. As a result of this experience, the mobilization protocol was changed as follows:

- Pin-out testing was changed to include the verification of no conductor-to-conductor shorting, in addition to proper pin-to-socket assignments; and
- All new cables are tested for proper pin-out assignments (plus verification that none of the conductors are shorted, per the new pin-out testing procedure) before they are placed into service.

This lesson is presented, because it explains why protocols evolve over time and gives some insight into the logic behind recommended procedures that might otherwise appear redundant or unnecessary.

### 4.3 Siting the Instruments

Siting the instruments begins with surveilling the preferred mounting locations and cable runs. Part of the process involves being prepared to explain to the appropriate crew member what is intended and how much time is needed to mount the instruments. When having discussions with the crew, it is important to emphasize that all safety equipment, operational fixtures, and painted surfaces will be respected, and that no trip hazards in passageways or stairways will be created. The crew will usually want to know the size and weight of instruments that will be deployed on the superstructure, including any cabling. High-latitude cruise discussions may also take into account the weight added by layers of ice and other safety issues.

► **Exercise 4.3** *What is a common and simple way to attach a reference sensor mount to a ship?*

The crew is responsible for the safety of the platform and all aboard, so compromise regarding a desired mounting location is frequently necessary. This means it is advantageous to have more than one location and more than one mounting option. The deployment options should include the preferred location for the acquisition computer and deck box. If an in-water system is being deployed, it is advantageous for the computer operator to quickly be on deck to help with any deployment issues that might arise, so proximity to the deck is important. In all cases, it is advantageous for the computer operator to be able to quickly determine stable solar illumination before and during data acquisition, if this cannot be done by the person(s) on deck.

Instruments must be strategically placed to return data of the highest quality (Fig. 1), but many of the best locations may not be available because of safety concerns, existing equipment, or a lack of accessibility while at sea. For the in-water C-OPS instrument, this requirement is easily satisfied, because the backplane is floated away from the platform. This work is usually done on the stern where there is a maximum amount of space and visibility of the

ocean. In addition, there is good comprehension as to whether or not the power and telemetry cable is free and clear of any submerged ship components, like the propeller.

In the case of BioSCAN, the bow is a preferred location, because this where the ship comes to a point. Consequently, the downward-viewing ( $L_T$ ) sensor can be pointed to either side of the ship's centerline without any part of the ship entering the FVA. In general, the BioSCAN frame must be higher than the nearest part of the ship's structure (Hooker and Zibordi 2005), which is also easily satisfied at the bow, because it is an area of open expanse.

The disadvantage of the bow is the deck is usually sloped, so it can shed water effectively. It is also where anchoring equipment and docking fixtures are located, which can cause awkward mounting possibilities, because they cannot be interfered with.



*Because the bow is where heavy seas usually first encounter the vessel, it is important to ensure sensors mounted on the bow can be removed quickly, if severe weather is forecast; this provides safety for the equipment, and also protects the ship by reducing the loading on whatever bow structures are involved that could break free.*

Small boats usually have minimal bow railing that is designed only to prevent a person from falling overboard, and not to secure a heavy piece of equipment, especially in a rough sea state. Consequently, whatever is used to establish a mounting fixture on the bow of a smaller vessel will likely require strength members for the railing and other spanners to distribute the load away from the railing.

Medium-sized vessels frequently have a sturdy railing around the bow that can accommodate a simple pipe structure to hold the sampling frame and still permit a person to safely stand on the deck and operate it. They also do not have significant anchoring and docking equipment, which facilitates a more straightforward installation.

Large ships, however, usually have bows with awkward geometries and access as a result of more massive anchoring and docking equipment and the need to deflect water away from the ship in heavy seas. Consequently, an open-pipe platform is often mounted on top of the bow to provide a safe area for the frame operator. The platform is usually built with pipe and fittings to form railing around three sides. The pipe railing can be used to affix a pipe to hold the sampling frame in the same fashion that is used to mount a solar reference.

In addition to the accessibility requirement (such as for cleaning the apertures and capping them to measure dark offsets), other factors to consider when evaluating alternative sites are soot from the engine room stacks, perturbations of the light field caused by reflections and shadows from the superstructure of the ship, etc. The height of the solar reference diffuser should be higher than any source of shading or reflections, so there is an unobstructed view of the sky. In general, the solar reference should be the highest piece of equipment on the deployment platform, if possible. A summary of the deployment principles for a large ship is presented in Fig. 11.

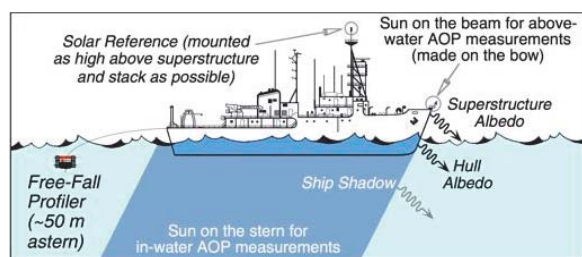

**Fig. 11.** A schematic representation of the platform perturbations associated with a ship and preferred deployment locations for AOP measurements.

Hooker (2010) presented a quantitative analysis of the impact of reference position on the R/V *Roger Revelle* (an ocean-class ship), and made a strong case for using a retractable mast as a viable option to other ship locations. The importance of taking the time to plumb the solar reference cannot be over emphasized. Although the vessel will pitch and roll, if the reference is properly mounted, the motions will move through the zero points for both axes and the angular distribution of the data will be as bias-free during the deployment as possible.

#### 4.4 Siting the Cable Runs

Once the locations of the instruments and the deck box with attendant computer have been determined, the next step is to determine safe routes to install (or *run*) the cable. Planning (or siting) the cable runs before installing the cable is more time efficient than having to remove a cable and start over, because of an unanticipated routing problem. If not already done so, introductions to the deck crew should be made. Each ship is a unique installation, and what was acceptable on the last ship is not necessarily acceptable on the next.

⚠️ *It is proper etiquette to discuss installation plans with the crew and to subsequently follow their directions, regardless of past experience or knowledge base.*

If the best routing to follow when installing cable is elusive, ask an appropriate crew member for advice. Mobilization is frequently done under a compressed time schedule, so it is best not to waste time by having to repeat a task—*do it right the first time.*

⚠️ ⚠️ *Be aware of, and prevent any vulnerabilities posed by, doors or hatches that can be opened and subsequently strike or pinch the cable.*

Routes that shelter the cable from weather and sunlight, as well as provide protection from ship's operations and personnel traffic, are preferred. Similarly, locations where the cable is naturally protected by the structures of the ship itself are considered advantageous.

⚠️ ⚠️ ⚠️ *Be aware that the cable must not interfere with the operation of safety equipment (e.g., a life ring, lifeboat davit, fire extinguisher, alarm, public address equipment, ladders, etc.) or an operational fixture (e.g., jacob's ladder, windlass, fairlead, cleat, etc.).*

The cable route must also provide attachment or *purchase* points where the cable can be secured, so it does not move from its intended location. The superstructure of a ship typically has many purchase points, whereas the bow and stern, which are principally open areas, do not.

⚠️ ⚠️ *Cable should not lay across the deck of a walkway, passageway, or gangway, because it potentially creates a tripping hazard; the cable should cross overhead, which might require the use of one or more standoff poles to support the cable.*

⚠️ *Be aware of any potential to interfere with any other ship's equipment not mentioned above—even if it appears to be used infrequently.*

▶ **Exercise 4.4** *What is a likely reason for avoiding ship's equipment that appears to be used infrequently?*

## 5. INSTRUMENT INSTALLATION

For the protocols presented here, the prioritization of tasks is assumed to result in the installation of the instruments before the cable is physically installed. For the circumstances wherein the opposite might occur, notes are provided in the subsequent sections to facilitate this case. Ships have strong railing to protect personnel on almost all decks (as do many offshore structures), so the installation protocols are based on using either 1 in (2.54 cm) 316 stainless steel (SS) pipe with national pipe thread (NPT†) as the principal structural element for the BioSCAN frame or solar reference when ship perturbations are not a concern.

If ship obstructions, reflections, or shadows are likely to occur during data acquisition, a Biospherical Mast for Advanced Solar Technologies (BioMAST) can provide significant mitigation. The BioMAST units are available as aluminum or powder-coated steel and have excellent corrosion resistance.

The solar reference described in these protocols includes the BioSHADE and BioGPS accessories, which are all three mounted to a 1 in 316 SS pipe nipple, so the 1 in pipe architecture is integral to the reference subsystem. The BioMAST mount includes a 1 in pipe coupler at the top, so it is compatible with the reference subsystem approach.

The specification to use 316 SS pipe or a BioMAST is for superior corrosion resistance and stability. It also ensures the mounting equipment will last through multiple deployments in the harsh marine environment.

⚠️ *Although alternative pipe specifications are suitable for short deployments, over the long term, the inevitable corrosion of other metals means the pipe becomes an undesirable source of particles.*

† NPT is a U.S. standard for threaded pipe and fittings wherein the thread is tapered at a rate of  $1/16$  per inch (6.25% slope), which will pull tight over a small number of turns.

- **Exercise 5.0** *Why is it important that the pipe used for sensor mounts not be corrosive and, thus, not a source of particles?*

## 5.1 Instrument Installation Tools

The presentation of the tools needed for the protocols is based on organizing them for specific tasks and keeping them in separate tool bags, which can be picked up and used for the associated task. By having separate tool bags, multiple personnel can work on multiple tasks without a conflict in tool availability, while keeping the amount of equipment that needs to be shipped to a minimum. The latter is particularly helpful when deploying on smaller vessels wherein storage space is at a premium.

- **Exercise 5.1** *What is a theoretical disadvantage with multiple tool bags—rather than just one big tool box—that might actually provide a practical advantage?*

The tools needed for instrument installation using 1 in 316 SS pipe or a BioMAST are part of the hardware tool bag, as follows:

- 1 ea Large tool bag (color coded or labeled);
- 1 ea Anti-sieze (or anti-galling) joint compound formulated for stainless steel, e.g., FASTORQ AG (FASTORQ, New Caney, Texas);
- 1 pk Disposable paper towels;
- 1 pr Aluminum pipe wrenches (10 in and 12 in);
- 1 ea Large slip-joint pliers;
- 4 ea 316 SS worm-drive hose clamps with  $\frac{1}{2}$  in bands in internal diameters of  $1\frac{1}{16}$ –2 in and  $2\frac{1}{16}$ –3 in;
- 4 ea Scaffolding clamp for 1 in pipe;
- 2 ea 316 SS smooth-band worm-drive hose clamps with  $\frac{1}{2}$  in bands in internal diameters of  $2\frac{3}{4}$ – $3\frac{3}{4}$  in and  $3\frac{1}{4}$ – $4\frac{1}{4}$  in;
- 1 ea Nut drivers in  $\frac{5}{16}$  and  $\frac{9}{32}$  in (7 mm) sizes;
- 1 ea Cordless  $\frac{1}{4}$  in hex-drive impact driver (e.g., Bosch model PS40, Gerlingen, Germany), with quick release screwdriver bits plus  $\frac{5}{16}$  and  $\frac{9}{32}$  (7 mm) hexagonal bits;
- 1 ea Conformable (to  $-18^{\circ}\text{C}$ ), all weather, heavy duty, abrasion resistant, fast buildup, black vinyl electrical tape, e.g., Scotch Super 88† (3M, St. Paul, Minnesota);
- 1 ea Three-axis level, e.g., QuadriLevel (Metrica S.p.A, Milan, Italy); and
- 1 pk Assorted solid rubber strips in different thickness up to  $\frac{1}{4}$  in (6 mm) for shimming material.

---

† Scotch Super 88 8.5 mil vinyl electrical tape has proved to be a durable and reliable product through more than 15 yr of fieldwork and is available in  $\frac{3}{4}$ , 1,  $1\frac{1}{2}$ , and 2 in widths.

The assorted rubber strips are used as shims on railing, which frequently has different upper and lower diameters, so a vertical strength member can be made plumb.

## 5.2 The Solar Reference

The reference subsystem, with both the BioSHADE and BioGPS accessories, is shipped in a specially-designed container that allows the light sensor and two accessories to be mounted on a 1 in 316 SS pipe during transport. The irradiance sensor, BioGPS, and BioSHADE assembly are mounted to v-blocks using smooth-band, worm-drive hose clamps with additional insulation. The subsystem is not shipped with the cables connected, which must be accomplished as part of initiating the cable run (Sect. 6.2.1).

- **Exercise 5.2** *What is the advantage of a smooth-band, worm-drive hose clamp, and how can it be improved?*

If a 1 in 316 SS pipe or a BioMAST is used to hold the solar reference plus BioSHADE and BioGPS accessories, installation of the reference and accessories is significantly simplified, because the 1 in pipe is compatible with the reference and accessories mount and BioMAST has a 1 in pipe coupler at the top of the highest section.

### 5.2.1 Stainless Steel Pipe and Fittings

As stated above (Sect. 5), 1 in 316 SS NPT pipe is recommended for the structural components of a reference mast, because its corrosion resistance provides needed sanitation to help keep the optical apertures clean. The 1 in diameter is chosen for its mechanical properties, and the use of commercially available pipe ensures the pipe and any needed fittings are available at a reasonable cost (recognizing that anything made from 316 SS is more expensive than alternatives, like 304 SS).

- **Exercise 5.2.1** *What is the difference between 304 SS and 316 SS?*

When two surfaces are connected together, the fundamental properties of the materials determine how the surfaces wear, particularly if the surfaces are metals in motion without benefit of conventional lubrication, e.g., when fitting a pipe to a coupler. Although machined surfaces appear smooth to the eye, at smaller scale the finished surfaces associated with conventional bearing applications are actually rough and irregular.

If two seemingly smooth metal surfaces are brought into contact, high points—or *asperities*—are the points of contact and not the nominal areas of the surfaces. Under static loading, the asperities deform until the contact area increases to support the load. If relative motion is introduced, e.g., when screwing together a pipe and coupler, *adhesive wear* or *galling* may occur in one or both surfaces. Adhesive wear results from the shearing of interface

oxides (protective to the base metals) followed by asperity (metal-to-metal) contact.

Under low stress, slight bonds form at the asperity contacts and subsequent motion produces plastic deformation with a loss of malleability resulting in fracture. Under sufficient loading, welding occurs under pressure, with the weaker of the two metals fracturing and yielding. These wear and fracture fragments can transfer back and forth between the surfaces, causing further damage.

As the loading and pressure increases, the fracturing and yielding associated with adhesive wear gives way to galling. The stronger bonds form over a greater contact area with gross surface damage and the asperities seize or freeze-up, such that further motion becomes impossible.

 *Galling occurs as the formation of a weld junction that is stronger than either of the base metals and represents a catastrophic failure.*

In the case of a pipe and a coupler, this means the coupler cannot be further tightened or loosened—the pipe and the coupler are welded together.

Galling is a potential problem in all types of stainless steel threaded assemblies. Consequently, stainless steel pipe requires an anti-seize (or anti-galling) joint compound formulated for stainless steel fittings (e.g., FASTORQ AG).

### 5.2.2 Pipe Assembly Protocols

When connecting two pieces of pipe, a fitting must be used to join the pipe (e.g., a coupler, elbow, or tee). In most cases, a coupler is used. If two references are mounted on the same base pipe, compatible back-to-back mounts can be used or a tee fitting, which allows two risers to be constructed, can be used.

1. A small amount of anti-seizing stainless steel joint compound (e.g., FASTORQ AG) is applied on the MR pipe threads and on the inside of the FG fitting.
2. The fitting is screwed onto the pipe by hand until snug, and then tightened using pipe wrenches.
3. When tightening a fitting with pipe wrenches, one wrench is positioned on the pipe and the other is placed in opposition on the coupler.
4. Use maximum grip and turning force, while ensuring an approximately  $\frac{1}{2}$  in gap is maintained between the shank of the hook jaw and the pipe itself, thereby allowing the pressure of the two gripping points (the heel jaw and the teeth of the hook jaw) to provide the gripping action of the wrench (allowing the back of the hook jaw to contact the pipe greatly reduces the gripping action of the wrench and can cause the wrench to slip or result in the failure of the hook jaw).

 *Do not use a so-called “cheater,” which is a piece of pipe slipped over a wrench handle to increase leverage, because it may result in the bending and breaking of the wrench handle, or it can slip off during use, all of which can cause injury. If greater leverage is needed use a larger wrench.*

5. The coupler is tightened against the retarding force applied by the wrench on the pipe which holds the assembly steady, thereby preventing the transfer of turning torque to the rest of the assembly, which might damage other components.

 *Do not over tighten the fitting, because this can lead to galling and a subsequent inability to disassemble the mast.*

6. Any excess joint compound that is extruded from the fitting is wiped away with a disposable towel.

► **Exercise 5.2.2** *What are the suggested pipe wrench sizes as a function of pipe diameter?*

### 5.2.3 Pipe Mast Installation Protocols

The reference mast is comprised of a 4 ft (1.2 m) base pipe, a 2–4 ft (0.7–1.2 m) riser, plus the solar reference assembly with BioSHADE and BioGPS accessories attached to a short piece of 1 in 316 SS pipe. The riser length is set by the height of the person who will cap and clean the reference diffuser, however, the sum of the base pipe and riser should be at least 6 ft (1.8 m) long. The first level of the railing can be used as a step (when safe to do so), and the mast can be held with one hand while the other hand is used for capping or cleaning. The height of the solar reference diffuser should be higher than any source of shading or reflections and ideally the highest piece of equipment on the deployment platform (Fig. 11).

► **Exercise 5.2.3** *What are some of the advantages of a modular mast made from commercial pipe and fittings?*

For the purposes of pipe installation protocols, three axes are considered: the vertical (upward and downward) axis, and the two horizontal axes perpendicular to the vertical. When a pipe is properly oriented with respect to the vertical it is plumb, and the two horizontal axes are level. Consequently, a three-axis bubble or *spirit*† level can be used to verify if a pipe is plumb. The basic mounting procedures are to mount and plumb the base pipe to the railing, attach the riser to the base pipe, and then attach the solar reference assembly to the riser. All pipe connections are accomplished using the procedures provided in Sect. 5.2.2. Although it is possible to first assemble the entire mast and then mount and plumb it to the railing, a fully assembled mast is top heavy and awkward to control. It is safer to assemble the mast in pieces.

† The word “spirit” is a synonym for “ethanol,” which is used as the liquid in a bubble level because of its low freezing point,  $-114^{\circ}\text{C}$ . Ethanol also has a low viscosity and surface tension, so the glass surface of the incompletely filled vial provides minimal interference with the motion of the bubble, thereby allowing the bubble to travel the tube quickly and settle accurately. A colorant (e.g., yellow fluorescein dye) is usually added to make it easier to see the bubble.



The first step in mounting and assembling the mast is to attach a coupler to the bottom of the base pipe, as long as it will fit and not interfere with subsequently plumbing the pipe when it is laid up against the railing. If there is no room for the coupler where the pipe sits on the deck, the exposed threads should be protected with another mechanism, e.g., a thread-protecting cap or heavy plastic wrapped with vinyl tape. The second step is to attach a coupler to the top end of the base pipe.

After the couplers have been attached to the base pipe, the base pipe is mounted against the railing using two scaffolding clamps or four stainless steel hose clamps. If the latter are used, two should be used at each connection point with one laid crosswise with respect to the other to form an ‘X-shaped fastening around the base pipe and horizontal railing. Each hose clamp should be tightened, but initially kept loose to position the components close to their anticipated final orientation. Because one hose clamp overlies the other, make sure access to both screw heads is maintained and the top clamp does not prevent the bottom clamp from tightening.

Before fully tightening the clamps, it is usually necessary to shim the connection points with pieces of hard rubber in order to plumb the base pipe, i.e., to make it vertical. A three-axis level simplifies the plumbing process. Because the shims are inserted between the pipe and the railing, it is frequently beneficial to tape the shims to the pipe using vinyl electrical tape to keep the shims from falling out of the expanse between the pipe and railing. A proper fitting of the shims frequently involves loosening the hose clamps to insert and tape the shims in place.

Because of the repetitive nature of the work required to plumb the base pipe, a cordless hex-drive impact driver will speed up the tightening and loosening of the hose clamps. Once the base pipe is close to vertical, it is usually advantageous to hand tighten the riser into the top base pipe coupler, so the three-axis level can be used unobstructed. Once the base pipe is plumbed, the riser should be tightened to the upper base pipe coupler using pipe wrenches.

One of the last steps in the procedure is to screw the reference subassembly onto the riser, which might have a simpler configuration than a subsystem involving BioSHADE and BioGPS. This requires holding the entire subassembly with coupler already attached over the riser, squaring the coupler to the riser pipe, and then rotating the subassembly to fasten the coupler to the riser pipe. The important part of the procedure is to keep the coupler and pipe properly squared to one another, so the riser pipe ridges engage the coupler grooves. There is usually sufficient moment arm with the assembly to tighten the connection without the need of pipe wrenches.

Once the mast has been erected and all components screwed together (Fig. 12), the flexibility of the mast with respect to anticipated wave conditions must be evaluated. If the mast exhibits motion to relatively small side forces, guy lines should be attached to limit the range of side motions.



**Fig. 12.** Pipe masts on the R/V *Gulf Challenger* showing the following: **a)** the C-OPS reference plus BioSHADE and BioGPS accessories, with guy lines for stabilization and slack cable coils to facilitate sensor handling (left); and **b)** the older (and larger) SuBOPS reference mounted to a v-block on a flat plate (right), wherein the slack coil is perpendicular to the image and not easily discerned.

#### 5.2.4 BioMAST Installation Protocols

For ships that do not have, or permit access to, high locations wherein a pipe mast will elevate the solar reference above perturbation sources, a BioMAST can provide sufficient vertical extent to significantly minimize or eliminate data degradation. The mast need not be mounted high on the ship if the elevated position sites the reference higher than the most substantial perturbation sources. The latter is a potentially difficult requirement on a large vessel, because of the height of the superstructure, and in some cases large masts are the only solution (Hooker 2010).

► **Exercise 5.2.4** *What is a likely disadvantage of a telescoping mast versus a pipe mast in winter conditions?*

With respect to a pipe mast, a BioMAST represents larger cross-sectional area and mass, which means it is subject to greater wind loading, ice loading, and ship motion. The additional loads need to be considered when installing the mast. The simplest mounting arrangement for a small BioMAST (e.g., the model EM15) is to mount it against a railing or existing shorter mast. The EM15 has a back plate with a bolt pattern that allows the mast to be clamshelled against railing using the matching metal plates and bolts provided with the EM15 mast.

Threaded rod can be bent around the form of whatever BioMAST is being secured to, or hose clamps can be passed through the bolt holes and attached around adjacent structural elements. An example of using bent threaded rods around an existing mast is shown in Fig. 13. When working with a BioMAST, which has a natural tendency to tip

over, safety lines or long cable ties (also called *tie wraps*) are useful during the installation process to restrain the range of motion to what is needed to install the mast.

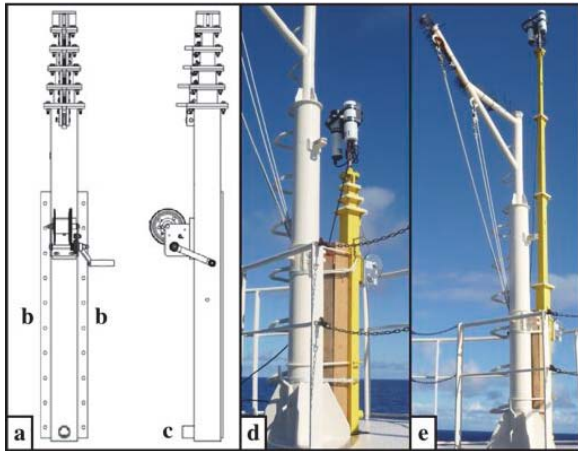

**Fig. 13.** An example installation of a BioMAST on the R/V *Hakuho Maru* showing **a**) front (left) and side (right) line-drawing views of the EM15 mast; **b**) the back plate with bolt patterns on the left and right sides; **c**) the hot air input port for thawing ice during winter conditions; **d**) the mast in the retracted position; and **e**) the mast fully extended.

Regardless of the mounting approach, BioMAST must be plumbed and this frequently requires the use of hard rubber shims. As in the case of the pipe mast (Sect. 5.2.3), if the shim is easily dislodged, vinyl electrical tape should be used to hold it in place until the compressional forces associated with the mounting process secure the shims.

### 5.3 Mounting the BioSCAN Frame

The BioSCAN frame is transported in a shipping case that does not allow the radiometers to be mounted on the frame. Consequently, mounting the BioSCAN frame includes attaching the optical instruments, interconnecting them with a Y-cable, and attaching the power-telemetry cable that goes to the deck box.

The BioSCAN frame has a 1 1/4 in 316 SS pipe flange fitting on the underside. A larger pipe diameter is used than for the solar reference, because the BioSCAN frame with sensors attached is heavier than the solar reference with BioGPS and BioSHADE accessories. The simplest mounting arrangement is to plumb a 4 ft (1.2 m) piece of 1 1/4 in 316 SS pipe at the desired location on the ship, which is usually the bow (Sect. 4.3), following the same procedures used for the solar reference mast (Sects. 5.2.2–5.2.3).

Once the 4 ft (1.2 m) piece of 1 1/4 in pipe is mounted plumb, the BioSCAN frame screws onto the pipe. The frame should not be overtightened, because it is advantageous to be able to remove the radiometers (and perhaps the frame) quickly, if severe weather is forecast. After the frame is secured, the two horizontal axes should be checked for level and adjustments made to the pipe if it is not. An

example easily built aluminum railing system for a bow platform to hold BioSCAN is presented in Fig. 14.



**Fig. 14.** A portable (all aluminum) open-rail platform for mounting the BioSCAN on the R/V *Pelican* while providing a secure area for the operator.

► **Exercise 5.3** What is another reason to not over tighten the fitting that mates the BioSCAN frame flange to the vertical 1 1/4 in 316 SS support pipe?

### 5.4 The C-OPS Backplane

The C-OPS profiler is transported in a specially designed shipping case that allows the radiometers to be mounted on the backplane and connected to the Y-cable. Consequently, it is usually not necessary to do any instrument installation tasks on the backplane. Nonetheless, the installation of the sensors are described, in case they have been, or need to be, removed and reinstalled.

Using Fig. 7 to set the orientation, the C-OPS optical instruments mount against v-blocks using two 316 SS smooth-band hose clamps. The radiometers are first slid through the open bands in their correct orientation. The instruments are then held loosely in place by tightening the two smooth-band hose clamps that hold them to the v-blocks (using a 9/32 in nut driver) so they can be moved up and down, but not fall out.

The v-blocks are set to their zero offset position, by loosening the fixed-point and rotation nuts on each v-block, and then sliding the v-block until it is positioned in the middle of the rotation arc. The orientation of each sensor is set by the end of the sensor that can be aligned to the top of the hydrobaric buoyancy chamber as follows:

$E_d$  The  $E_d$  sensor is properly aligned when the gap between the cosine-collector end cap and the instrument housing is aligned with the top of the red foam, i.e., the top of the optical end cap extends 0.28 in above the top of the red flotation (or 0.61 in for the dark cap);

$L_u$  The  $L_u$  sensor is properly aligned when the cap on the aperture is flush with the bottom of the v-block, i.e., the top flat of the bulkhead connector is 0.32 in below the top of the red foam; and

$E_u$  The  $E_u$  sensor is properly aligned when the flat on the top of the bulkhead connector is flush with the top of the float.

These orientations are used to compute the offsets of all sensor apertures with respect to the pressure transducer.

- **Exercise 5.4** *What is the consequence of not correctly specifying the offsets of the light sensor apertures with respect to the pressure transducer?*

## 5.5 The Deck Box and Computer

On many ships, a sacrificial piece of plywood is attached to counter tops to permit the use of screw eyes plus line or bungee cord to hold equipment in place. When used for computers or other devices with a lid (e.g., a deck box), the line or cord frequently interferes with the closing of the lid or top.

An alternative and equally reliable system for mounting a computer and deck box that does not fail in heavy seas is industrial-grade hook-and-loop (Velcro) fasteners that have an adhesive on one side. The advantage of this system is it does not mar the surface it is applied to, it can be peeled off at the end of the campaign, and it does not interfere with the operation of lids and latches.

The inventory for securing the deck box and computer is as follows:

- 1 ea Tool bag (color coded or labeled);
- 1 ea Oval head stainless steel diagonal cutters (e.g., model 906, General, New York, New York);
- 1 ea Stainless steel scissors;
- 1 ea Premium duct tape, 1.88 in wide 45 yd roll, e.g., Industrial Grade Duck Tape (ShurTech Brands, Avon, Ohio);
- 1 ea Adhesive-sided industrial hook and loop fastener tape in 3 ft (0.9 m) length, e.g., Quake Tape (Q-Safety, Glendora, California);
- 1 pk Single-use isopropyl alcohol cleansing pads, e.g., Chempad (Chemtronics, Kennesaw, Georgia);
- 1 pk High-visibility (e.g., neon pink, red, yellow, or orange) 6 in (15.2 cm) small cable ties (e.g., ACT Fastening Solutions, Gardner, Massachusetts).

The duct tape is used for short-term applications wherein a small amount of holding power is anticipated to satisfactorily secure the deck box or computer. Day campaigns in protected inland waters frequently do not require something more substantial than duct tape to hold equipment in place. The residual adhesive left behind when the tape is peeled off can be removed with an alcohol cleansing pad.

The computer should be mounted close to the deck box, if possible, so the digital display on the deck box can be easily seen. The display provides status messages that are useful to verify nominal operations or to understand fault conditions.

- **Exercise 5.5** *What is one of the potentially hazardous accidental misuses of industrial hook-and-loop fasteners that can lead to damaged equipment?*

## 6. CABLE INSTALLATION

Once the locations of the instruments and cable runs have been determined, and the instruments mounted, the next step is physically installing (or *running*) the cables between the instruments and the deck box. The direction chosen to commence the work is important, because it can determine where excess cable (defined here as an amount beyond one or two coils held within the hand) is stowed. It is usually preferable that excess cable is stowed where it can cause the least interference to ship operations. At the same time, a certain amount of *slack* cable is beneficial at both endpoints to provide strain relief and to permit changes (anticipated or not) in the configuration or operation of the instruments.

From a general perspective, cable is usually run from the instrument to the deck box on large vessels, and the opposite direction for small ships. The reasoning has to do with available space. On a small vessel, the laboratory spaces are necessarily small and there is usually not much room for coiling up an excess amount of cable, either in the laboratory area or immediately outside where foot traffic is high and passageways are narrow. The most convenient place for excess cable on a small ship is where the instrument is mounted.

The length of cable between two points is referred to as the *cable run*. For the purposes of describing the task of installing cable, a cable run is divided into three parts:

- Initiation, starts the run and is usually associated with connecting the cable to the instrument (deck box) on a large (small) vessel;
- Extension, connects the start of the run to the end of the run and is usually associated with safely affixing the cable to the ship and through cable passes; and
- Termination, ends the run and is usually associated with connecting the cable to the deck box (instrument) on a large (small) vessel.

Installing all three parts of a cable run requires the same tools. The extension task typically requires the most analysis and effort, because this is where most of the cable is affixed to the ship. *Each time cable is attached to, or strung between, ship fixtures, care must be exercised to ensure the cabling does not interfere with ship operations or create safety concerns.* What is considered acceptable varies as a function of the ship and its operations. The protocols presented here are based on deployments involving many different domestic and international field campaigns and all the platform types presented in Sect. 1.2.



- **Exercise 6.0** *When planning a cable run should the amount of cable that is strung inside the vessel be minimized or maximized?*

## 6.1 Cable Installation Tools

It does not require many tools to install cable. A recommended inventory involves two tool bags, one for tape and cable ties, and one for connectors (i.e., locking sleeves, dummy plugs, etc.). The inventory for the tape and cable ties bag is as follows:

- 1 ea Tool bag (color coded or labeled);
- 1 ea Oval head stainless steel diagonal cutters (e.g., model 906, General, New York, New York);
- 1 ea Conformable (to  $-18^{\circ}\text{C}$  or less), all weather, high-stretch, fade-resistant, colored vinyl electrical tape (e.g., Scotch 35 in yellow, red, orange, violet, blue, brown, green, white, gray, and black);
- 1 ea High-visibility (e.g., neon colors, pink, red, yellow, or orange) standard cable ties in lengths of 7, 11, and  $14\frac{1}{2}$  in (17.8, 27.9, and 36.8 cm, respectively);
- 1 ea Cable tie tensioning device or *gun* (e.g., Greenlee Communications, formerly Paladin Tools, model 1828.1); and
- 1 ea Heavy duty clear box sealing tape (e.g., Scotch 3750).

The black vinyl tape is used for applications that are considered permanent beyond the present field campaign or where a black color is beneficial. The white vinyl tape is typically reserved as a tracer color, wherein a wide swath of white tape is applied and then a narrower swath of a different color is applied.

- **Exercise 6.1** *What are the advantages of using high-visibility (e.g., neon) cable ties?*

The connectors tool bag serves two purposes: a) storage for tools needed to work with connectors, and b) storage for spare dummy plugs and locking sleeves, including those removed during the mobilization process. The inventory for the connectors bag is as follows:

- 1 ea Tool bag (color coded or labeled);
- 1 ea Dow Corning 111 grease (preferably dispensed into a smaller container, because a 5.3 oz tube greatly exceeds what is needed for many field campaigns);
- 1 pk Disposable paper towels;
- 1 ea Oval head stainless steel diagonal cutters (e.g., model 906, General, New York, New York);
- 25 ft (7.6 m)  $\frac{1}{4}$  in (6 mm) nylon braided line;
- 1 ea Miniature (i.e.,  $\frac{1}{16}$  in) flat-bladed screwdriver;
- 1 ea Metal (dental) pick for releasing the split ring from a SubConn locking sleeve; and

- 2 ea SubConn female 6-pin dummy plug connected to a SubConn male 6-socket dummy plug with mated locking sleeves.

The  $\frac{1}{4}$  in line is for securing equipment that must be released and secured on a routine basis, as well as for guys and standoffs. For example, if each day the sea cable is disconnected from the extension cable leading to the deck box, a short length of the  $\frac{1}{4}$  in line is used to secure the extension cable (Fig. 15) and the cable bucket (after dummy plugs are attached to the loose cable ends).



**Fig. 15.** An example of a cable extension that is disconnected and secured each day, so the cable bucket and C-OPS profiler can be stowed for safety.

## 6.2 Initiating a Cable Run

If not accomplished in a prior mobilization, color coding the cables and connectors with vinyl electrical tape, including the deck box and instruments, helps prevent improper connections. Color coding will also ensure proper identification of the instruments when the connection is made to the deck box, and is particularly useful if someone unfamiliar with the equipment is assisting, perhaps due to the person familiar with the equipment responding to a different problem or a change in personnel scheduling.

- **Exercise 6.2** *When applying color coded tape to a cable, where should it be applied?*

The solar reference, C-OPS backplane, and BioSCAN frame can all have multiple sensors and there is one principal connection for each subsystem of instruments. The connection that provides the principal power connection is color coded, so it is obvious where the power connection from the deck box is made. For the reference this is an instrument bulkhead, but for the BioSCAN frame



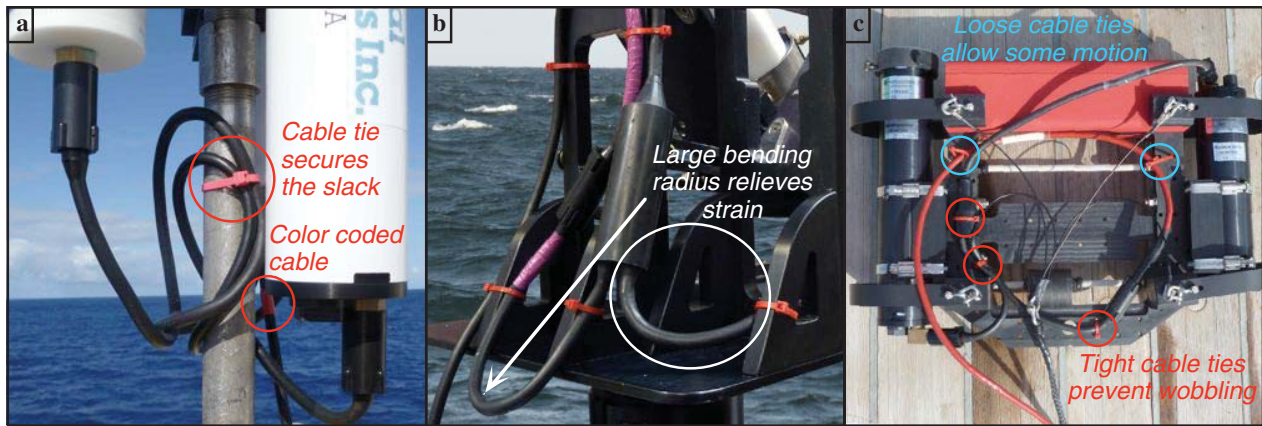

**Fig. 16.** Examples of initiating a cable run: **a)** a close up of slack cable on a solar reference, which is formed into loops and affixed to the instrument mast with a (pink) cable tie to provide strain relief, and color coding used with a reference; **b)** ; and **c)** the loose and tight cable ties on the C-OPS backplane, with the former allowing a range of motion and the latter providing strain relief while preventing strumming which can lead to wobbling of the backplane during descent.

and C-OPS backplane the main connection is a Y-cable MP/MR connector.

A standard color convention is to label the solar reference red, orange, or yellow, the sea cable is usually blue or green, and the BioSCAN Y-cable is violet or brown. These color choices are arbitrary and are selected as mnemonics: the reference views the sun, which is yellow, orange, or red; the C-OPS instrument profiles the blue or green ocean; and the BioSCAN uses the remaining colors.

As noted above, white is reserved as a tracer, which can be helpful when many systems are deployed on the same platform. If only one system is deployed, color coding need not be sophisticated; it need only be consistent.

When running cable from an instrument subsystem to the deck box, the cable connector that plugs into the instrument supplies power with an FS/FG connector, and the cable connector that plugs into the deck box receives power with an MP/FG connector. Both terminus ends of the cable have FG locking sleeves, so an interface cable or its assembled equivalent is needed.

### 6.2.1 The Solar Reference

The main connection for a solar reference with BioGPS and BioSHADE accessories is to the BioSHADE at the MP/MR bulkhead using an FS/FG connector. The other two connections on the BioSHADE end cap are FS/MR bulkheads that supply the power and telemetry for the BioGPS and the irradiance instrument. The latter two are connected to the BioSHADE using short interface cables.

⚠️⚠️⚠️ Whenever connecting a solar reference with a BioSHADE present, *the cable must be dedicated to only this purpose and the BioSHADE may only supply power and telemetry to the BioGPS and irradiance instrument from the two FS/MR bulkheads.* Catastrophic instrument damage may occur if a) the BioSHADE and

any other instruments or accessories are powered together from the deck box on a Y-cable, or b) instruments or accessories in excess of the BioGPS and irradiance instrument are connected to the BioSHADE FS/MR bulkheads.

An overview picture of a solar reference with all three components is presented in Fig. 12a, and details of the cable installation in terms of color coding and strain relief are presented in Fig. 16a.

► **Exercise 6.2.1** How does a coil of slack cable attached to a fixture (e.g., a pipe mast, as shown in Fig. 16a), provide strain relief?

### 6.2.2 The BioSCAN Frame

For a BioSCAN frame, the main connection is to the Y-cable MP/MR connector using a FS/FG connector. The other end of the Y-cable has two FS/FG connectors to interconnect the two radiance instruments at their MP/MR bulkheads. Because the BioSCAN frame is designed to rotate, it is important to leave sufficient slack between the two fixture points that span the main connection, so the frame can be turned more than 180° in both rotational directions. Additional details of proper cable strain relief for a BioSCAN frame are presented in Fig. 16b.

► **Exercise 6.2.2** What is the principle vulnerability of using a Y-cable to power two instruments?

### 6.2.3 The C-OPS Profiler

For a C-OPS profiler, the main connection is to the Y-cable on the back plane at the MP/MR connector. The other end of the Y-cable has two FS/FG connectors that interconnect the two radiometers at their MP/MR bulkheads.

The C-OPS profiler is transported in a specially designed shipping case that allows the optical instruments

to be mounted on the backplane and connected to the Y-cable. Consequently, it is usually not necessary to do any cabling tasks on the backplane, except to connect the sea cable to the Y-cable and secure the requisite components. An example of the cabling secured to the backplane is presented in Fig. 16c.

The C-OPS in-water instrumentation requires a sea cable with MP/MR on the deck box end and FS/FG on the backplane end. The sea cable is stored in a plastic bucket sized for the length of the cable. Holes in the bottom allow water to drain away. Handles allow the bucket to be moved into position on the deck for the deployment of the profiler, and then moved back to a safe location for stowage between stations.

A sea cable is coiled into the cable bucket using a *figure-eight* method. Approximately 1 m of slack cable at the MP/MR (deck box) end is placed outside the bucket, and then CW coils of cable are put into the bucket until all the cable is safely coiled into the bucket with the FS/FG instrument end lying on top.

Each coil put into the bucket will either lie naturally in the bucket on top of the previous coil or will want to be coiled in the opposite (CCW) direction. The CCW coils are reoriented by flipping them under the present coil. If taken out of the bucket together, the top coil of an over-and-under pair can be flipped over to create a figure-eight with the partner coil.



*Do not force the cable to lie as sequential coils in the same circular orientation, because this will add tension to the cable and increase the likelihood of cable snarls when the cable is removed from the bucket during profiling.*

► **Exercise 6.2.3** *How can the cable initiation in Fig. 16c be improved?*

## 6.3 Extending a Cable Run

If the distance between an instrument subsystem and the deck box cannot be spanned with a single interface cable (FS/FG on one end and MP/FG on the other), one or more extension cables are needed. Extension cables have FS/FG on one end and MP/MR on the other, and are used first on a large ship (i.e., connected to the instrument and then run towards the deck box). The run is completed by adding an adapter or interface cable at the MP/MR end.

► **Exercise 6.3** *If the only two cables that will span a cable run are two interface cables, how can they be re-configured to connect properly?*

### 6.3.1 C-OPS Extension Cables

The sea cable for a C-OPS by definition creates a multiple cable run, because the sea cable is configured as an extension cable. This is done so a sacrificial (less expensive) interface or adapter cable is added to the MP/MR

(deck box) end of a sea cable. In addition, a Y-cable is used on the backplane to connect the radiometers to the sea cable. A Y-cable allows the sensors to be connected using a minimum number of bulkhead connectors.

The extension of the deck box MP/MR end of a sea cable requires one or more cables. On a small boat, an interface or adapter cable is used, and on a large ship, one or more extension cables might be needed to get close to the deck box, and then an interface or adapter cable is used to make the deck box connection. The sea cable is the most valuable of the cables, so it is advisable to maximize how much of it is available in the cable bucket. The cable is safest in the bucket and this also ensures the maximum amount of cable can be deployed into the water for profiling.

► **Exercise 6.3.1** *What is another advantage for having a sea cable that can be disconnected close to the cable bucket?*

### 6.3.2 BioSCAN Extension Cables

Like the C-OPS backplane, the BioSCAN instrument system uses a Y-cable on the frame to connect the two radiometers to the cable from the deck box. This means deployment of the BioSCAN frame subsystem will always involve two or more cables. For a large ship, the cable from the deck box is frequently an extension cable, and for small boats it is usually an interface cable.

► **Exercise 6.3.2** *If the BioSCAN (two radiometers) is mounted on the bow of a ship along with a surface reference (1 radiometer) without BioGPS and BioSHADE accessories, how can all three devices be powered and the data acquired with one power-telemetry cable going back to the deck box?*

### 6.3.3 Extension Cable Practices

Running an extension cable from a solar reference, the C-OPS sea cable, or the BioSCAN frame to the deck box involves a number of considerations aboard ship. Not all possible considerations are presented, but a sufficient diversity are provided to establish a framework for determining what to do when unexpected challenges are encountered.

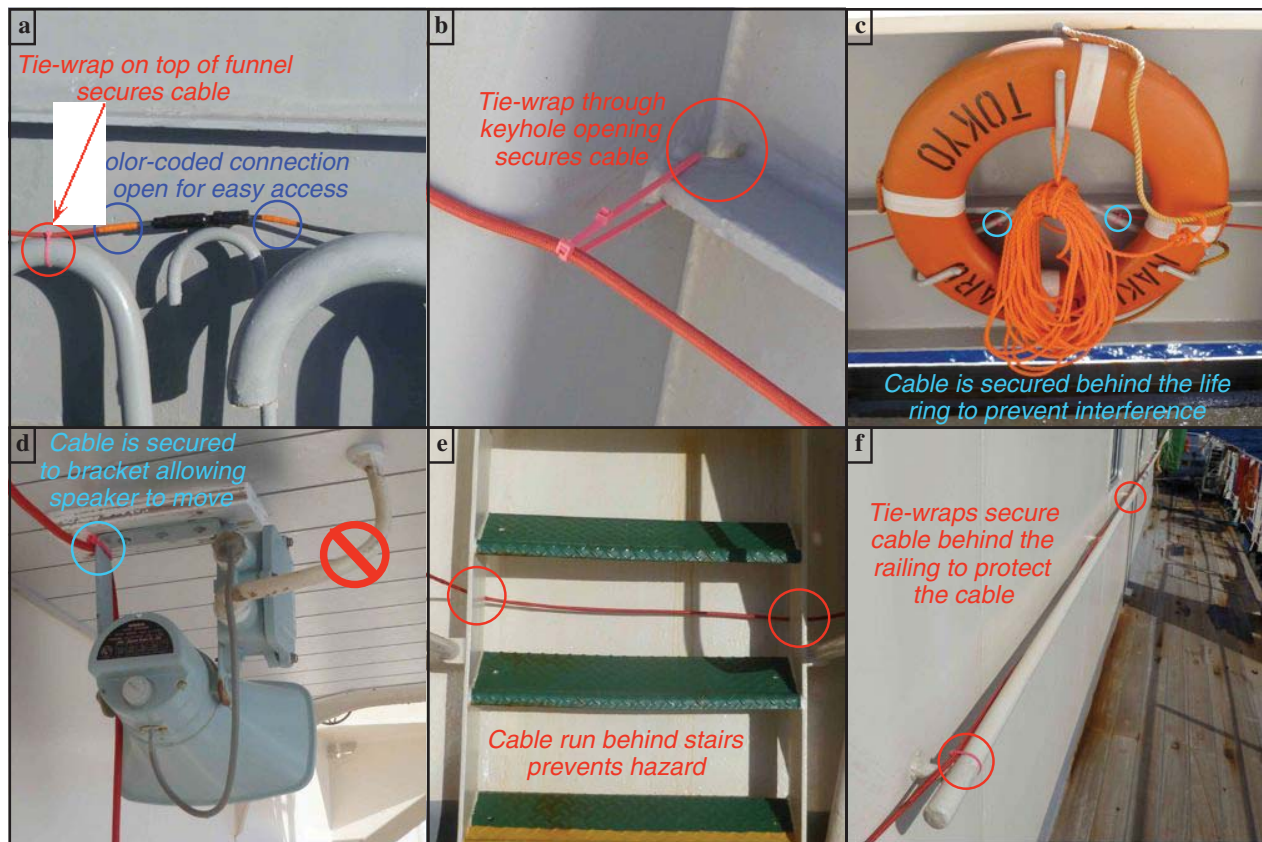

The primary objective when extending a cable run is to affix the cable securely to the ship, all the while minimizing the risk that the cable can be damaged by ship's operations and preventing any interference with the operation of ship's equipment—*especially safety equipment*. Minimizing the opportunity for damage means being aware of the tasks the crew performs, as well as the ship's response to inclement weather.

The cautions and awareness required for properly siting a cable run (Sect. 4.4) are also applicable to extending the cable run (Fig. 17). Some practical aspects of the installation procedures are as follows:



**Fig. 17.** Examples of extending a cable run on the R/V *Hakuho Maru*: **a**) cable is secured to the top of a funnel, well clear of the discharge point, and a connection (properly color coded) is made in the open for easy access; **b**) cable is secured to a keyhole in the bulwark; **c**) cable is secured behind a life ring to prevent interference with the use of safety equipment; **d**) cable transitions from an overhead passage to a lower point using a speaker bracket (note the reminder to *not* attach cable to the ship's electrical wire); **e**) cable is run *behind* stairs to prevent a trip hazard and protect the cable; and **f**) use of railing to span between the bow and stern, wherein the cabling is cable tied behind the railing to protect it.



1. Secure the cable with high-visibility cable ties with a color that is distinctive from black, white, or neutral, which are frequently the colors used by the crew.
2. Set the cable manually by pulling the tape section through the head (in the correct direction) or a cable tie tensioning device may be used to apply a cable tie with a specific amount of tension.
3. Cut the protruding tape section of the cable tie *flush* with the head.

   Do not leave a protruding tape section, because it can have a sharp edge which might cause injury, especially to hands softened from repeated exposure to water (some cable tie guns cut the tape off when the proper tension is achieved).



4. Secure the cable only to passive mechanical fixtures, if possible.

 Do not attach cable to the ship's cabling or any other cable, because the other cable could fail under the added load, especially during severe weather (plus if the other cable needs to be removed, perhaps

as the result of a fault condition, both cables will become unsecured).

  Do not attach cable to moving parts, because this adds mechanical and vibrational wear; if this is unavoidable, add chafe protection and stiffening members to restrict motion response where appropriate.

5. If cable troughs are available, attach the cable to the framing members of the cable trough.
6. Where possible, protect cable by securing it so as to not expose it to likely deck operations or traffic patterns.

  Do not attach cable to anything that might heat up as a result of normal operations, because this might melt the insulation materials of the cable; if this is unavoidable, add heat shielding and cable protection where appropriate.

7. If two cables must be joined to complete a run, tape the locking sleeves together to protect them from so-



lar insulation and to signal caution to anyone who might consider disconnecting them.



In those rare cases wherein it is advisable to lay cable across a deck or to run it where windage can cause it to move and chafe, *the cable should have an overwrap of a sacrificial material (e.g., canvas or rubber) applied as protection.* In the case of a cable laying on a deck, the overwrap should include additional material to keep the assembly flush to the deck and bright coloration to provide an alert for the presence of a tripping hazard.

► **Exercise 6.3.3** *What is a common feature of ship decks that can provide a convenient and secure location to run cable on top of a deck?*

## 6.4 Terminating a Cable Run

Terminating a cable run involves the final connection to the last component, which is the deck box on a large ship and an instrument or Y-cable (interconnected to instruments) on a small boat. For a cable run involving an extension cable, an interface or adapter cable must be added. If there is an excess of slack cable at the end of the run, the majority of it should be coiled up and secured outside the data acquisition area for a large ship and at the instrumentation for a small boat. A small amount of slack cable is needed near the connection to the deck box to provide strain relief plus positioning and repositioning options.

Before connecting the cables to the deck box, verify the cables are being connected to the correct ports on the side of the deck box. For C-OPS, this means the sea cable is connected to the bulkhead connector labeled “Port 1 Underwater” and the solar reference cable is connected to the “Port 2 Surface” bulkhead connector. For BioSCAN the BioSCAN frame instruments are connected to “Port 1 Frame” and the solar reference is connected to “Port 2 Reference.”

Finally, inspect the overall installation and confirm the color coding verifies the connections are correct and the cable runs are *squared-away*. For example, police the installation areas and look for any tools, cable ties, and debris (e.g., cut cable ties). It is important to pick up and properly dispose of any plastic trash (Sect. 12.5). For any uncertainties in the installation in regards to ship equipment, consult a crew member.

► **Exercise 6.4** *What is a sensible precaution before connecting any cables to a deck box?*

## 7. TEST DEPLOYMENT

If being used for the first time, or if being deployed in a significantly different water mass or on a different platform, C-OPS and BioSCAN need to be tested for proper *trim* before commencing data acquisition. “Trim” here

refers to the optical apertures being pointed to within 1–2° of their designed pointing angles—on average and with no discernible bias—while being subjected to the motion of the platform involved, e.g., the descent of the C-OPS backplane, the motion of the ship, etc. If the platform involved is not in motion, e.g., if an offshore structure is being used, the non-moving components should be pointed to within 0.1° of their designed pointing angles.



*One objective of the test deployment is to verify the apertures in motion are traversing their designed angles without a discernible bias, thereby safeguarding the quality of the observations obtained.*

In other words, it is completely acceptable that the apertures move, but the sampling should be equally obtained on both hemispherical sides of the designed pointing angle. Designation of the two hemispherical sides as positive and negative is arbitrary. As long as the designation takes place in software and is understood as up and down, left and right, or in and out with respect to the designed pointing angle, the practitioner can make compensatory adjustments until there is no discernible bias.

The other objectives of the test deployment are as follows:

- a) Verify the functionality of all electrical components, including the operation of each R/T handset;
- b) Confirm the procedures used to initiate and terminate a cast;
- c) Agree on the actions to be taken in the event of likely deployment problems;
- d) Acquire familiarity with handling and operating the instrumentation; and
- e) Practice the communications protocols between the on-deck instrument operator and the in-lab computer operator acquiring the data.

The latter three are especially important for new practitioners. If both C-OPS and BioSCAN are tested together, their data products can be intercompared to provide additional functionality testing (Hooker et al. 2002).

The tools needed for sensor deployment are as follows:

- 1 ea Large tool bag (color coded or labeled);
- 3 ea Rechargeable, floating, and submersible VHF R/T handsets (one is a spare);
- 1 ea <sup>5</sup>/<sub>32</sub> in hexagonal ball-point driver to loosen and tighten the BioSCAN azimuthal band collet;
- 2 ea Line-handling gloves that keep the arms and hands dry while deploying the C-OPS backplane or working around wet components; and
- 1 ea UV-blocking and sun-shielding eye ware (that can be worn over prescription glasses) with an eye protection factor (EPF) of 9–10;
- 1 ea Sun screen with a sun protection factor (SPF) of 30+; and



- 1 ea Collapsible hat with an ultraviolet protection factor (UPF) protection of 50+.

The latter three items are for safe viewing of the solar disk to verify cloud-free data acquisition opportunities and safe exposure to sunlight while working in exposed conditions.



There is no cure for sunburn, so being “sun wary” is always prudent, especially for practitioners with a fair complexion. If sunburn exposure results in fever, chills, upset stomach, and confusion, a doctor should be consulted.

- **Exercise 7.0** What is the difference between SPF and UPF?

## 7.1 R/T Communications

A VHF radio is, by definition, a marine radio and operates on standard, international frequencies (between 156.000 and 162.025 MHz) known as channels. Technically, a VHF radio can only be used on the water (including rivers and lakes).



Once on shore, a VHF radio should not be used (except to test operability), according to Federal Communications Commission (FCC) rules.

Transmission power for R/T communications ranges from about 1–25 W. The maximum line-of-sight range is up to 60 nmi (111 km) between antennas on tall ships and hills, and 5 nmi (9 km) between small boats at sea level. Frequency modulation is used, with vertical polarization, which means the antennas have to be vertically oriented for good reception. R/T handsets are, therefore, well suited for most field campaigns wherein the assembled team is almost always all localized around the same platform.

An R/T is the easiest, most convenient method of relaying communications at sea; all that is necessary is that the sender pick up a handset, select the agreed upon channel for communications, and speak into the microphone or *mic*. An R/T network or *net* would quickly become unusable, however, if everyone on the net failed to follow the same rules and procedures. Much of what is accomplished over an R/T net involves proper techniques and training, coupled with common sense and experience.

It is impossible to cover all situations that may arise when using R/T voice communications. The perspective adopted here is that the R/T handset will be used almost exclusively by the on-deck operator of the instrumentation and the in-lab operator of the data acquisition computer. It is also assumed that the bridge will be monitoring this traffic in case the ship has to maneuver or respond to what is happening with the instrumentation and personnel.

R/T protocols are based on so-called *voice procedures*, which include a variety of techniques used to clarify, simplify, and standardize spoken communications over two-way radios. These protocols are in use by the military, civil aviation, first-responder (e.g., police and fire) dispatching

systems, and citizens’ band (CB) radio, to name a few. The objectives of R/T protocols are to maximize clarity and reduce misunderstanding.

Some aspects of voice procedures are understood across many applications, but significant variations exist. The military of North Atlantic Treaty Organization (NATO) countries use similar procedures in order to make cooperation easier, and pseudo-military organizations often base their procedures on NATO radio protocols. The most basic aspects of the protocols are usually referred to as R/T discipline, which is a set of procedures that all R/T communicators are expected to adhere to.

- **Exercise 7.1** What would be a likely disadvantage of using cellular telephony for two-way communications, if it were available?

### 7.1.1 R/T Handset

R/T communications is a method of conversing on half-duplex† communication lines using a button to switch between audio reception and voice transmission modes. An R/T handset is also called a transceiver, because it can both transmit and receive radio communications, albeit not simultaneously. The push-to-talk or press-to-transmit (PTT) button on the handset keys the microphone and allows the speaker to transmit voice over the selected VHF channel (or frequency). Anyone on the net that is tuned to the selected channel will hear the transmission if they are within signal range and if the signal quality is sufficiently above the noise threshold (discussed below).

For example, large ships will be supervised by a traffic controller near commercial ports, and will use an assigned radio frequency to hear and respond to instructions. They can also hear each other’s transmissions, which allows them to take turns speaking. The conversations are coordinated using procedures and words that allows each party to understand who is the addressee and addresser, what is occurring that might be situationally important, and when the conversations are finished. This allows everyone involved to be aware of each other’s actions and intentions, without the distraction of background noise from the ones who are not speaking.

- **Exercise 7.1.1** What happens when two R/T operators transmit at the same time?

An example R/T handset is depicted in Fig. 18 and has the following features: a) a connector for an external speaker and microphone; b) a PTT button; c) a button to

† A duplex communication system has two connected parties or devices that can communicate by transmitting and receiving signals with one another. A half-duplex system provides transmission and reception, but only one at a time, i.e., a party must wait for the other party to stop transmitting before initiating a transmission. A full-duplex system allows both parties to simultaneously transmit and receive.

immediately switch to the channel 16 and 9 distress frequencies; d) volume and squelch control; e) a frequency scan function; f) a built-in microphone; g) a connector for an antenna; h) a display for active functions; i) up and down buttons for setting channels, volume, and squelch; j) a button to switch to and select weather channels; k) selection of high or low power transmission (if one or more operators are inside the ship, high power is frequently needed); l) a power on/off button; and m) a built-in speaker.



**Fig. 18.** An example R/T handset (model iM36, Icom Inc., Osaka, Japan) with antenna not attached and some important features labeled.

Other features that are useful in a marine VHF handset are as follows:

- A clip, so the handset can be attached to the outside of a buoyant work vest;

 *Make sure the handset has a floating and submersible rating, so if the handset is dropped overboard it is very likely that it can be retrieved as functional.*

- A lanyard, so the handset can be secured to the user while allowing a reasonable range of motion; and
- Voice activation for the operator working on the deck, wherein both hands are frequently in use.

When an R/T handset is powered on and no one on the net is transmitting, all that is heard is noise. The noise originates from atmospheric conditions, leakage from neighboring channels, and local interference sources. The squelch control is a circuit function that filters out the noise, so only the desired and sufficiently strong input signal is heard. The squelch is usually set with a knob (or push buttons, as in Fig. 18) to establish the threshold at which signals will open (un-mute) the audio channel, so they can be heard over the speaker. Backing off the control will turn on the audio, and the operator will hear white noise (also called squelch noise) if there is no signal present.

The usual operation is to set the squelch threshold until the channel just shuts off, so only a small signal above the threshold is needed to provide audio output over the speaker. If a weak signal is distracting, the operator can

adjust the squelch to open only when stronger signals are received. If the squelch is held open, continuous noise will be heard until someone on the net starts speaking.



The point to remember when using squelch is that an incoming signal has to overcome the ambient noise for the squelch control to let the transmission through. If an incoming transmission is quiet or faint, the squelch control cannot distinguish between the signal and the background noise, so the transmission will not be heard. If the squelch is set too high, some messages will not be received.

### 7.1.2 Guiding Principles

The guiding principle for working quickly and efficiently over an R/T net, is to use standard procedures. The techniques presented here are the most common and when mastered, will allow the practitioner to be capable over a large range of communications needs, including emergency situations. Indeed, one of the reasons this material is presented and emphasized is to increase the safety associated with working in the field.

 *When using a radio, say what what needs to be communicated without unnecessary repeats, because extraneous words lead to avoidable confusion.*

Keep in mind that the objective is to deliver the message the first time, so this becomes second nature. The more serious or complex the situation, the more important adherence to the procedures presented here becomes. Practicing proper radio procedures makes emergency radio procedures automatic and reduces confusion.

   *The capability to work quickly and efficiently during an emergency requires the effortless use of approved radio communication procedures as if they were second nature—which is only possible with practice—so it is important to use every R/T communication as an opportunity to practice.*

The guiding principles of good R/T communication are as follows:

- Hold the handset securely, applying firm pressure on the PTT button to prevent unintentional release and consequent signal dropout, while orienting it to prevent the possibility of having feedback added to other background noises;
- Maintain the correct distance between lips and handset, for which a distance of about 2 in (5 cm) is correct for most handsets (if the distance is too great, speech becomes inaudible and background noises interfere, and if the distance is too small, blaring and blasting result);
- Remember the hand-to-voice coordination needed to begin a transmission (pressing the PTT button before speaking) and to end it (releasing the PTT button after speaking);

- Answer a call promptly and succinctly, *while remembering excessive preliminary exchanges waste time*;
- Listen and think before transmitting, *while remembering that unanticipated break-in causes confusion and often blocks a transmission in progress to the extent that neither transmission gets through*;
- Use plain language and common terminology procedure words—more properly *prowords*—as defined in Sect. 7.1.4 and Appendix D, *while remembering not to replace prowords with plain language equivalents*;
- Avoid the use of slang or technical jargon, unless it is operationally necessary, and



*Do not use indecent, obscene, or profane language;*

- Use correct voice procedures (Sect. 7.1.6);
- Speak clearly and slowly, *while remembering that both slurred syllables and clipped speech are hard to understand* (a common error among novices is failure to emphasize vowels sufficiently);
- Speak in a moderately strong voice to override background noises and to prevent dropouts, while remembering to maintain a normal speaking rhythm by grouping words in a natural manner and sending the message phrase-for-phrase instead of word-for-word;
- Use a voice technique that enhances communication, e.g., use standard pronunciation, maintain adequate pauses, speak directly into the microphone, and avoid extremes of pitch (high pitch cuts through interference, but is unpleasant if too high, whereas a lower pitch is more pleasant, but difficult to understand through background noises if too low); and
- Keep all transmissions brief, simply phrased, and to the point—*do not send unnecessary transmissions*.

► **Exercise 7.1.2** *In addition to machinery noise, what is a common source of noise on an outside deck that can degrade R/T clarity, and how can it be mitigated?*

### 7.1.3 R/T Transmission Components

R/T transmissions should be as short and concise as possible without sacrificing clarity. It is important that all personnel using voice communications be instructed in the proper use of the handset and R/T equipment. They should also be aware that there is no expectation of privacy for R/T communications.

Before an R/T handset is used, the communications channel must be agreed to. There are more than 80 U.S. VHF channels (including alternates), plus 7 weather channels. Many channels have preassigned functions and should not be used for general communications, and some of them are for reception only (e.g., the weather channels).



*Channel 16 (156.800 MHz) is the international distress, safety, and calling channel, which shall only be used for emergencies, and channel 9 (156.450 MHz) can also be used in some locations as a secondary call and distress channel.*

Many R/T handsets have a separate function button to go to channel 16 and toggle between channels 16 and 9 (as shown in Fig. 18).



*Channel 13 (156.650 MHz) shall only be used to contact another ship when there is danger of collision.*

Ships that are required to carry a radio (i.e., vessels that are 20 m in length or longer) must monitor channels 13 and 16; the U.S. Coast Guard (USCG) and most coastal base stations maintain a listening watch on channel 16.

Boaters (i.e., field teams) should normally use channels listed as being appropriate for non-commercial communications. These include channels 68 (156.425 MHz), 69 (156.475 MHz), 71 (156.575 MHz) and 72 (156.625 MHz), with the latter for intership (i.e., ship-to-ship) communications only.

In radio communications, a call sign is a unique designation for a transmitting station, and is used to identify the stations on a net. Full call signs need only be used at the initiation of a conversation, because the use of full call signs on every transmission is unnecessary and wastes time. Whenever there is a risk of confusion, however, full call signs should be used. For the examples presented here, the full call signs are “Dry Lab” and “Aft Deck,” which are shortened to “Lab” and “Deck” after the net is first established.

Messages are constructed using call signs, prowords, and plain words. The latter form the majority of the message content that is communicated, whereas the prowords clarify intent and action, i.e., they reduce the possibility of confusion that is inherent in the diversity of word choices that are possible in plain language.

When transmitting to initiate a conversation, the addresser shall adhere to the following sequence of call signs and prowords (there are no plain words to be misinterpreted):

1. Press the PTT button;
2. Say addressee’s call sign twice;
3. Say “This Is” once;
4. Say addresser’s call sign once;
5. Say “Over”; and
6. Release the PTT button.

The “This Is” prowords clarify who is the addresser, and the proword “Over” ends the conversation segment and alerts the addressee that a response is expected and should be transmitted.

For the call signs identified above, the initiating transmission (or traffic) would be, “Dry Lab, Dry Lab; This

Is Aft Deck; Over.” The initiating response from the addressee would be, “Aft Deck, Aft Deck; This Is Dry Lab; Over.” With the initiation completed, the call signs would be shortened to “Deck” and “Lab” during the continuation of the conversation. If there was a “Chem Lab” on the net that might participate in the conversation, “Dry Lab” would either not be shortened to avoid confusion with the other “Lab” call sign, or “Dry” and “Chem” could be the shortened call signs.

Continuation of the conversation involves the same format, except shortened call signs are used (where possible), the “This Is” prowords are omitted, and message text (if any) is inserted after the addresser’s call sign. For example, “Lab, Deck; station in two minutes; Over.” The addressee would then respond, “Deck, Lab; Affirmative; Over. In this example, “Affirmative” is a proword indicating reception and understanding of the message

The addresser is responsible for ending the conversation, by sending a message in which no reply is expected, which is signaled to the addressee by using the proword “Out” instead of “Over.” For example, in the continuation of the conversation above, “Lab, Deck; Out.” ends the conversation.

► **Exercise 7.1.3** *What is a common mistake for new R/T practitioners that leads to incomplete messages?*

#### 7.1.4 R/T Discipline

The foundation of R/T discipline is to understand the prowords that all R/T communications rely on. A relatively small number of prowords must be learned to allow basic functionality on an R/T net, which are as follows (a more complete listing of useful prowords is provided in Appendix D).

**Affirmative** Yes, confirm, permission granted, or correct. With a poor quality connection, the words “Affirmative” and “Negative” can be mistaken for one another, so “Yes” and “Confirm” are also used. Sometimes a *double click* sent over the radio by keying the mic twice to produce an audible “-” sequence (like Morse code) is used when the addressee is unable to talk due to heavy workload or stress.

**Confirm** Affirmative.

**Negative** With a poor quality connection, the words “Affirmative” and “Negative” can be mistaken for one another, so “No” is also used.

**No** Negative.

**Out** This ends my transmission and no answer is required or expected.

**Over** This ends my transmission and a response is required, so go ahead and transmit. Contrary to popular belief, “Over” and “Out” are never used at the same time, because

their meanings are mutually exclusive. (Historically, “Over and Out” was used to mean “Over to you, and when you are done, I am Out.” The same meaning can be communicated with just “Out,” as in “Lab, Deck; station in two minutes; Out.”

**Radio Check** How do you Read me, i.e., what is my signal strength and clarity (Sect. 7.1.5)?

**Read** Hear, as in “I Read you Loud and Clear.”

**Roger** I received the message (even without understanding it), also “Roger That”; a “Roger” response to a “Radio Check” means “Loud and Clear” (Roger was the U.S. military designation for the letter “R,” as in “received,” from 1927 to 1957). It is important to not say “Roger” when actually meaning “Affirmative” or “Negative.”

**This Is** Identifies the addresser (the person speaking).

**Wilco** I understand and will comply with the contents of the received message (noting that “Roger” and “Wilco” are redundant, because “Wilco” includes the acknowledgement function of “Roger,” so “Roger Wilco” should not be used).

**Yes** Affirmative.

► **Exercise 7.1.4** *What is the difficulty with the above example, “Lab, Deck; station in two minutes; Out.” for new practitioners, and how can the messaging be improved?*

#### 7.1.5 Radio Checks

Radio checks provide the means to verify the circuit is operating, to check the strength and clarity of the speech on the net, and to verify the speech is clearly understood and of normal tonal quality for the type of circuit under test. The degree of signal strength and clarity of the transmission may be stated by word or number combinations as given in Table 1 (e.g., “Loud and Clear” or “5 by 5”, noting the use of “by” to separate numeric reporting).

**Table 1.** The degree of signal strength and clarity of a transmission expressed in numbers and terms.

| <i>Signal Strength</i> |                | <i>Signal Clarity</i> |                 |
|------------------------|----------------|-----------------------|-----------------|
| 5                      | Loud           | 5                     | Clear           |
| 4                      | Good           | 4                     | With Distortion |
| 3                      | Weak           | 3                     | With Noise‡     |
| 2                      | Barely Audible | 2                     | With Fading‡    |
| 1                      | Noise†         | 1                     | Inaudible       |

† Inaudible

‡ But Readable

Voice checks are essential before commencing operations relying on R/T communications, both before deploying to the field and prior to their initial use in the



**Table 2.** The identity (ID) of the NATO phonetic alphabet and numbers for radiotelephony with the syllable to be emphasized during pronunciation shown in all capital letters. Note the altered pronunciations, which are used to prevent ambiguity, e.g., “five” and “nine” can sound the same over the radio, so they are pronounced “fife” and “niner” for clarity. And for international clarity, “Juliett” is spelled with a “tt” construct for French speakers, because they may otherwise treat a single final “t” as silent.

| ID | Word    | Pronunciation | ID | Word     | Pronunciation | ID | Word   | Pronunciation |
|----|---------|---------------|----|----------|---------------|----|--------|---------------|
| A  | Alfa    | AL FAH        | M  | Mike     | MIKE          | Y  | Yankee | YANG KEY      |
| B  | Bravo   | BRAH VOH      | N  | November | NO VEM BER    | Z  | Zulu   | ZOO LOO       |
| C  | Charlie | CHAR LEE†     | O  | Oscar    | OSS CAH§      | 1  | One    | WUN           |
| D  | Delta   | DEL TAH       | P  | Papa     | PAH PAH§      | 2  | Two    | TOO           |
| E  | Echo    | ECK OH        | Q  | Quebec   | KEH BECK§     | 3  | Three  | TREE§         |
| F  | Foxtrot | FOKS TROT     | R  | Romeo    | ROW ME OH     | 4  | Four   | FOW ER§       |
| G  | Golf    | GOLF          | S  | Sierra   | SEE AIR RAH   | 5  | Five   | FIFE§         |
| H  | Hotel   | HOH TELL      | T  | Tango    | TANG GO       | 6  | Six    | SIX           |
| I  | India   | IN DEE AH     | U  | Uniform‡ | YOU NEE FORM  | 7  | Seven  | SEV EN        |
| J  | Juliett | JEW LEE ETT   | V  | Victor   | VIK TAH§      | 8  | Eight  | AIT           |
| K  | Kilo    | KEY LOH       | W  | Whiskey  | WISS KEY      | 9  | Nine   | NIN ER§       |
| L  | Lima    | LEE MAH       | X  | X-ray    | ECKS RAY      | 0  | Zero   | ZE RO         |

† Or SHAR LEE§

‡ Or OO NEE FORM§

§ Altered pronunciation.

field. These checks are important because they allow faulty equipment to be identified and replaced before operations are commenced (which means all deployments should have at least one spare radio). When testing a radio or establishing a communication net, a standard short count, e.g., “1, 2, 3, 4, 5, -5, -4, -3, -2, -1” (where “-” is “minus”), should be spoken directly into the microphone at a normal voice level and cadence of speech. By having the addresser use an easily anticipated sequence of words, the addressee can more properly evaluate if the spoken words are clearly understood, because there is little ambiguity in what each word was intended to be. When the addresser finishes the test, the addressee should report signal strength and clarity, and then follow the same voice check procedure the original addresser used.

► **Exercise 7.1.5** *Why is blowing air from the lips over a handset microphone an inadequate radio check?*

### 7.1.6 Voice Procedures

It is useful to adhere to NATO voice procedures for R/T communications, because they are likely to be somewhat familiar to novice and experienced practitioners alike. The NATO phonetic alphabet (Table 2), more accurately known as the International Radiotelephony Spelling Alphabet and also called the International Civil Aviation Organization (ICAO†) phonetic or ICAO spelling alphabet, as well as the ITU‡) phonetic alphabet, is the most widely used spelling alphabet.

† The ICAO is the United Nations agency concerned with civil aviation.

‡ The ITU is the agency of the United Nations which regulates information and communication technology.

To enhance clarity and reduce misunderstanding from similarly sounding words, prowords with specialized meanings (Sect. 7.1.4 and Appendix D) are preferentially used in radio communications in English-speaking countries and in international radio communications wherein English is the common language (e.g., maritime and aviation communications).

► **Exercise 7.1.6** *Assuming the operators in the above R/T traffic are experienced and have deployed the pro-filer many times, what would be a shortened, but equally effective exchange between the Deck and Lab?*

## 7.2 Functionality Test

Whenever an instrument system is transported, it is advisable to perform a functionality or *bench* test at the destination, prior to deploying the *in situ* instruments. In many cases it is advantageous to be able to do this test quickly and in a small amount of space, so visual confirmation that everything is correctly configured is easily obtained. The functionality test should be performed with shorter unequivocally functional cables, e.g., laboratory cables, if possible.

► **Exercise 7.2** *What is the advantage of using laboratory cables for the functionality test?*

The instruments are typically placed on a bench top, connected to the correct deck box port ports, and a serial cable from the computer is connected to the deck box. Typically this is an RS-232 cable, but a USB cable can also be used. The Y-cable routing on the C-OPS backplane allows the underwater instruments to be tested in the shipping container by connecting a laboratory cable to the MP/MR connector on the Y-cable.



*Do not test the solar reference with shadow band attachment in its shipping container—the shadow band must be free to move whenever the deck box is powered.*

The shadow band might have a reusable cable tie that constrains the motion of the shadow band during shipment. It is very important to remove the shadow band from its shipping container and to remove any restraint if present. The solar reference must be positioned so the shadow band is free to move throughout its functional range (about 225°).

The primary purpose of the functionality test is to expose any existing problems and establish a solution. If the test reveals spares are necessary, and if the test is done soon after arriving at the destination, the maximum amount of time is provided to locate a solution from the recommended spares inventory (Sect. 9.2) or place an order for an overnight shipment.

### 7.2.1 Deck Box Functionality

The BioSCAN and C-OPS instruments are powered using a deck box. The deck box is usually powered with an AC adapter (12 VDC at 8.3 A output), which also charges the internal battery. The C-OPS power-up sequence is shown below as a series of eight primary steps, with some steps having secondary steps (identified with letters as being representative, but not completely comprehensive). The C-OPS power-up sequence is shown, because it is a little more complicated than the BioSCAN sequence.

Verify the deck box AC adapter is plugged in and the Charger Power LED is lit, before proceeding (although in some cases, e.g., small-boat operations, a functionality test might be performed using deck box battery power, because an alternative power source is inactive). If external power is applied, but the Charger Power LED is not lit, check the cabling connections back to the power source.

The deck box is powered on using the latching power switch (Fig. 8), which must be lifted up before moving it, and then it will latch into the new position. For each power-up step, the deck box display is shown in green typewriter typeface and explanations of the deck box messages are shown in slanted typeface. The C-OPS configuration for the power-up sequence is as follows:

- Port 1 The underwater port is connected to the C-OPS backplane that has  $E_d$  and  $L_u$  instruments with the latter also containing a pressure transducer and a water temperature probe;
- Port 2 The surface port is connected to the solar reference subsystem that has an  $E_d(0^+)$  instrument plus a BioSHADE and BioGPS.

All three radiometers have 19 channels.

The first step in the power-up sequence describes the deck box, including the communication protocol and the firmware.

1. **Deckbox Standard 115200,N81 v:1.33 12/18/11 HDpx Waiting to stabilize** *Description of the deck box; baud rate, no parity, 8 bits, 1 stop bit; the firmware version; and wait message.*

The second step activates Port 1 at maximum voltage to check the power consumption. If sufficient power is drawn to indicate that a sensor is connected (step 2a), the deck box waits until the remote subsystem has stabilized (step 2b), as indicated by an increasing list of periods (“.”) in the last line of the display.

- 2a. **Activating Port 1 Drawing 190.4mA** *Port 1 activated and current draw is checked.*
- 2b. **Activating Port 1 Drawing 190.4mA Stabilizing .....** *Several seconds will elapse during initialization of the Port 1 instrument(s).*

The deck box gradually reduces power to the port 1 subsystem until it reaches the required voltage as reported by the underwater instruments (step 3). This allows the power to be optimized to the cable lengths that are being used. Note the large power draw is due to the long cable being used (a bench test will use considerably less power).

3. **Activating Port 1 Optimizing: Port1 11.3v 79.5mA Tag: 3 Ed@Depth** *The voltage reported by the instrument is reduced to an optimum of about 7 V to reduce power and heat.*

After the port 1 sequence is completed, it is repeated with port 2 (step 4), which in this case, is connected to a surface reference, BioGPS, and BioSHADE.

4. **Activating Port 2** *Port 2 is activated.*

The fifth step starts the BioSHADE motor and is used to determine the voltage drop over the cable length.

- 5a. **Activating Port 2 Drawing 166.0mA Stabilizing .....** *Port 2 consumes much more current than a radiometer, because of the BioSHADE.*
- 5b. **Motor setup @ port 2 Preparing motor Power: 18.8v 0.20A** *The voltage drop and power consumption over the cable is determined from the motor.*

The sixth step adjusts the power sensed at the end of the cable during motor motion.

- 6a. **Motor setup @ port 2 Preparing motor Drawing 402.3mA** *The current draw increases as the motor is used to move the shadow band over the solar diffuser.*
- 6b. **Motor setup @ port 2 Adjusting line drop - moving motor - Power: 16.3v 0.57A** *Starting at the upper limit, the voltage level is slowly lowered while the motor is moving the shadow band.*
- 6c. **Motor setup @ port 2 Adjusting line drop - moving motor - Power: 14.0v 0.64A** *Intermediate messages display the reduction in power consumption as the voltage is decreased.*

- 6d. Motor setup @ port 2  
Adjusting line drop  
- moving motor -  
Power: 14.1v 0.58A

*When the target voltage at the shadow band is reached, the process stops and the motor stops moving.*

The seventh step reports a summary of the sensors found, and then the power is turned on for port 1.

7. 2 devices on port 1  
3 devices on port 2  
Rechecking with both ports on.....

*The number of devices is reported,  $E_d$  and  $L_u$  on port 1, plus  $E_d(0^+)$ , BioSHADE, and BioGPS on port 2).*

After a delay, the eighth step provides a complete inventory of the attached devices and their aggregator tag numbers.

- 8a. Aggregator 1  
19 channels  
105 bytes  
Tag: 1 Ed surface
- 8b. Aggregator 2  
21 channels  
113 bytes  
Tag: 2 Lu@Depth
- 8c. Aggregator 3  
19 channels  
105 bytes  
Tag: 3 Ed@Depth
- 8d. Aggregator 7  
1 channels  
29 bytes  
Tag: 7 GPS
- 8e. Aggregator 8  
1 channels  
31 bytes  
Tag: 8 Shadowband

*The instruments with both ports on are reported as a sequence of aggregator messages.*

*The  $L_u$  instrument, which has 21 channels (19 wavebands, pressure, and water temperature), is tag 2.*

*The  $E_d$  instrument, which has 19 channels (19 wavebands), is identified as tag number 3.*

*The BioGPS accessory has only 1 channel (the GPS) and is identified as tag number 7.*

*The BioSHADE accessory, with 1 channel (the motor), is identified as tag number 8.*

The ninth step completes the process and ends with a display showing the voltage and current for various parts of the system.

- 9a. Ready...  
26.5C
- 9b. Vext: 13.0V, 1.21A  
Chgr:15.9V, 0.00A  
Bat: 13.8V, 0.00A  
10.3V180mA 16.4v406m

*Initialization complete and deck box temperature.*

*This is the display that is normally seen after successful initialization (described below).*

If the deck box is running on battery power, the display is not backlit to conserve power.

- 9c. Vext: 0.2V, 0.09A  
Chgr:0.1V, 0.09A  
Bat: 13.0V, 0.16A  
1.2v0mA 1.1v0mA

*The deck box is using battery power (Vext is about 0V), and there are no instruments connected.*

Because microradiometers and their attendant aggregators self organize, it is important to observe the deck box displays during power up. If a sensor, e.g., an individual channel in an optical instrument fails to report, the

subsystem will organize into a functional state with the errant channel missing and turned off. If this is not detected by the operator, and if the data acquisition software does not check if the powered on system is not configured as anticipated, the missing channel will be undetected.

If BioSHADE is being used, another functionality check that can be determined during the powering of the deck box is to visually verify the shadow band is moving through its entire range of motion from one side of the irradiance instrument to the *home* position below the opposite side.

► **Exercise 7.2.1** *If the deck box is malfunctioning, what is a good way to record the messages generated by the deck box, so they can be studied more carefully and perhaps transcribed for the manufacturer?*

## 7.2.2 BioSCAN and C-OPS Functionality

Although the deck box functionality test establishes the instruments able to report, it does not establish unequivocally proper configuration. The latter requires the data acquisition software, because it allows the values coming from the instruments to be inspected. This inspection will reveal if an instrument is returning data that is out of bounds or if an anticipated channel is not reporting.

After powering up the deck box, confirm the serial connection from the deck box to the computer is properly connected. If the RS-232 (9-pin) connection is used, a serial adapter or *dongle*, will usually be needed to convert the cabling to USB. Power up the data acquisition software and use it to verify all optical channels are reporting for each instrument and that the values are at the dark levels.

Inspect the ancillary channels, e.g., tilt and roll in the solar reference and profiler (if the testing is for C-OPS), and verify the values being reported are sensible. For example, position the reference so it is approximately plumb and verify the vertical tilt is close to zero. Rotate the reference through a positive-to-negative pitch and roll sequence and verify correct response.

If C-OPS is being tested and it is laying on its side, reorient it vertically and verify the vertical tilt is approximately zero. Rotate the profiler through a positive-to-negative pitch and roll sequence to verify correct response. Check the water temperature value and confirm it is reasonably close to air temperature.

The data acquisition software should also display the data sampling rate (nominally 12 or 15 Hz), voltage levels at the instruments (nominally 6.5 VDC for the profiler and 6.2 VDC for the reference with BioSHADE and BioGPS), and deck box power (nominally 12 VDC).

If BioGPS is being used, the date and time values can be verified, as can the longitude and latitude (e.g., with a handheld GPS or the GPS on the platform).

► **Exercise 7.2.2** *What additional simple procedure can be used to verify the individual light instruments are responding as anticipated?*



### 7.3 Deploying the Solar Reference

The C-OPS and BioSCAN solar reference is designed to be pointed at a zenith angle of  $0^\circ$ , i.e., pointed straight up or plumb, so the cosine collector can collect a planar measurement. For a platform in motion, e.g., a ship, it is not necessary for the reference to be mounted on a gimbal, as long as the reference is plumb before sailing and the ship maintains a level trim at sea. The latter is not an unusual requirement, because almost all ships maintain a rather level trim. Ship operations are safer to conduct and fuel efficiency is maximized if the ship remains trimmed.

► **Exercise 7.3** *What kinds of changes in solar illumination are acceptable on a moving platform?*

### 7.4 Deploying the BioSCAN Frame

Confirm all optical apertures are clean and collect on-deck dark data for all radiometers by placing opaque caps on the apertures. *Dark data must be collected for all three gain stages.* A total of at least 1,024 records per gain setting should be collected, because this allows a power spectral density (PSD) analysis of the data using fast Fourier transform (FFT) techniques. The latter allows, for example, confirmation that no AC 60 Hz contamination is present in the data. Remove the caps after the dark data have been collected, and release the slack in the cable that is attached to the sea cable.

The BioSCAN above-water radiometers are typically pointed to a nadir angle of  $40^\circ$  for the sea-viewing ( $L_T$ ) instrument and a complementary zenith angle of  $40^\circ$  for the sky instrument ( $L_i$ ). These angles are set by movable plates on the frame, which should be checked before a campaign commences and intermittently throughout the campaign or immediately after the system is perturbed.

During data acquisition, the frame is rotated into the sun plane and the solar compass (Fig. 19) is used to verify the instruments are pointed directly at the Sun. This task aligns the shadow from an upward-pointing thin rod with the large mark immediately behind the rod when the frame is pointed into the sun plane. The position of the azimuthal band at the base of the frame is used to then rotate the frame perpendicular to the sun plane by adding or subtracting  $90^\circ$  with respect to the sun plane reading.



**Fig. 19.** The BioSCAN solar compass **a**) pointed (down) into the sun plane (left), and **b**) pointed (CW) perpendicular to the sun plane (right).

The final position is checked using the solar compass to verify the shadow from the rod falls on the large mark that is  $90^\circ$  away from the sun plane mark and in the correct direction. The direction of perpendicular rotation with respect to the sun plane is arbitrary as long as the sea-viewing instrument views the water and is pointed far from the deployment platform. If both perpendicular positions result in views of the sea surface, the one that has the sea-viewing instrument pointed farthest from the deployment platform should be used which for a ship means the Sun is kept amidships and the radiometers point to the bow.

Typically, the BioSCAN is deployed on a reasonably large vessel such that there is a deck operator of the frame and a data acquisition operator for recording the data for each data acquisition event or cast. It is advisable to record at least 1,024 data records from the instruments, because this will permit proper glint filtering and allow the aforementioned PSD analysis of the data using FFT techniques.

In terms of communications between the two operators established in Sect. 7.1.3, the basic sequence involves the deck operator establishing that conditions are stable, pointing the frame into the Sun plane, and then rotating the frame  $90^\circ$  away from the Sun. In each case the computer operator is told what the azimuthal band reading for the frame is, as follows:

Deck: “Lab, Deck; BioSCAN in position with stable sea and sky conditions, Over.”

Lab: “Deck, Lab; Roger, Over.”

Deck: “Lab, Deck; Sun at Wun Ait Six, Over.”

Lab: “Deck, Lab; Roger, Sun Wun Ait Six, Over.”

Deck: “Lab, Deck; sea at Too Seven Six, Over.”

Lab: “Deck, Lab; Roger, sea Too Seven Six; recording data, Over.”

Deck: “Lab, Deck; standing by.”

Usually, three sequential casts are collected for each sampling opportunity, and then a BioSHADE cast is made (if it is being used). It is also typical for the direction of the surface swell to be measured while noting if the direction is towards or away from the observer.

If the wind speed is not being recorded by a separate device mounted on the deployment platform, a handheld anemometer, e.g., Kestrel 1000 wind meter (Nielsen-Kellerman, Boothwyn, Pennsylvania), can be used. In this case, the deck operator will collect the wind speed data while the optical data are being recorded, and report a representative (average) value to the computer operator at the conclusion of the data acquisition sequence. Similarly, if GPS is not available on the ship, a handheld unit can be used by the deck operator and reported once data acquisition commences.

► **Exercise 7.4** *When there are two sea-viewing options with BioSCAN, why is the position that has the sea-viewing instrument pointed farthest from the deployment platform selected?*



## 7.5 Deploying the C-OPS Backplane

The C-OPS in-water radiometers are pointed to a nadir angle of  $0^\circ$  for the  $L_u$  or  $E_u$  instruments and a zenith angle of  $0^\circ$  for the  $E_d$  instrument. The profiler is designed to descend with average vertical tilts of  $5^\circ$  or less, although typically an average vertical tilt of less than  $2.5^\circ$  can be achieved. The sea cable and ambient currents can pitch the sensors out of the vertical. The v-blocks that hold the instruments can be rotated to counter the average influence of these sources of pitch by moving them in the opposition pitch direction (Sect. 7.5.3). To minimize self-shading effects the Sun should be kept on the platform side that the C-OPS instrument is deployed.

When not being deployed, the profiler is stowed in a secure location. A large basket with a white sheet on the bottom can be used for this purpose (Fig. 20). The sheet can be used as a cushion, and as a shield against solar insolation. Fold the sheet in half, wrap it around the profiler so the weight of the instrumentation keeps the sheet in place, and then keep it wet with fresh water. The water weights the sheet (which helps prevent it from blowing away) and keeps the underlying equipment cool.

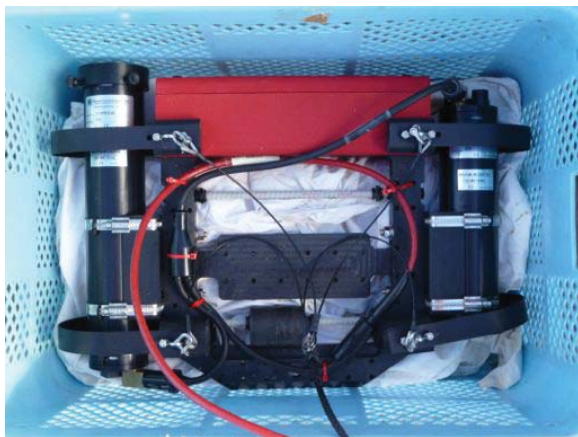

**Fig. 20.** The C-OPS profiler in a basket on top of a white sheet on the R/V *Hakuho Maru*.

 While waiting for a deployment, do not allow the in-water instruments to bake in the sun uncovered, because excessive heat will result in notably higher dark currents and a thermal shock when the instrumentation is deployed into the much cooler water.

► **Exercise 7.5** What is unusual about the configuration of the C-OPS profiler shown in Fig. 20 and what advantage does it provide?

### 7.5.1 Preparing for Deployment



Confirm all optical apertures are clean and collect on-deck dark data for the solar reference and the C-OPS backplane instruments by placing opaque caps on the radiometer apertures. Dark data must be collected for all three gain stages and the procedure used should also tare the

pressure transducer, so the atmospheric contribution to the measured in-water pressure can be removed. Remove the caps after the dark data have been collected, and release the slack in the cable that is attached to the sea cable.

Although cable snarls are reduced with the figure-eight cable coiling method, they are still possible. When cable is pulled from the bucket, some coils that should logically be on top of a prior coil will be below that coil, so more than one coil will be pulled from the bucket when the cable is dispensed and their orientation will be reversed. Consequently, a fair lead should always be used when dispensing cable. A fair lead is a straight unobstructed course of a line, or cable in this case, between two points. One reason the cable is kept in a bucket connected to another cable with slack in it is so the cable bucket can be moved around to establish a fair lead and to minimize the length of the lead. In most cases, the fair lead will be between the cable bucket and the point where C-OPS is being deployed over the side of the platform (Fig. 21).



**Fig. 21.** A fair lead between the cable bucket and the point where C-OPS is being deployed over the stern of the R/V *Hakuho Maru*.

   Do not establish a course for the cable that will expose it to any snags that could cut the cable or the person working with the cable.

Based on the water depth and optical complexity of the water mass, the descent rate and surface loitering characteristics of the C-OPS backplane must be selected. The descent rate is controlled by adding or removing buoyancy as flotation (Fig. 7n) or weight (Fig. 7p) discs, whereas the surface loitering is a function of the descent rate and how many compressible bladders are put into the hydrobaric buoyancy chamber (Fig. 7l). In shallow water, especially if the bottom is rough, a downward-pointing spar can be attached to the bottom of the backplane (Fig. 7q).

For very shallow and optically complex water, a terminal velocity of less than  $10 \text{ cm s}^{-1}$  is desirable. Although

C-OPS can be trimmed to fall even slower, if there are significant surface gravity waves present, the rotary motion of the waves can keep the profiler from sinking below the depth of wave influence, because the rotary will buoy the profiler back up to the surface.

For the open ocean wherein it might be desirable to reach the depth of the chlorophyll maximum (DCM) or the 1% light level, faster descent rates will be required to overcome cable consumed by the drifting vessel and subsurface currents. The selected descent rate will depend on the length of the sea cable, the desired depth, and anticipated cable loss due to horizontal advection.

Another factor to consider, particularly in the open ocean, is the presence of a strong thermocline or other circulation features with significant horizontal shear (e.g., an undercurrent). If the momentum of the profiler (mass times velocity) is too low, it is possible the profiler might not push through a high-shear feature and the depth of the cast will be less than desired. It is not unusual for profilers to slow down as they descend into a high-shear feature even if they are able to descend through it.

The data acquisition computer operator and the deck operator should check their radios for proper channel setting plus loud and clear communications. If radios are not necessary, because of the proximity of the two operators (e.g. small-boat operations), this step is not necessary and is omitted. In some cases, a third party acts as a relay for the communications between the two operators, e.g., if one or both radios have failed or if the size of the vessel easily accommodates relay communications. In this case, both operators should review the communications command set with the relay person to ensure familiarity.

Another important aspect of discussing communications is to establish what will happen when the profiler drop command is given. It is important that the deck operator understands that when the command is given the profiler will be hauled gently to the surface, so the cast begins as shallow as possible. By giving the drop command first and then hauling in on the cable, the computer operator will have sufficient time to start recording the data before the profiler reaches the surface.

► **Exercise 7.5.1** *What is a good habit to learn in order to overcome a common omission when preparing to deploy the C-OPS backplane, especially if there are unanticipated problems, that some software might not detect?*

### 7.5.2 Trimming the Profiler

Profiler buoyancy is adjustable to ensure the profiler is trimmed to be almost neutrally buoyant, but slightly negative. At this point, the relationship between the near-surface behavior and the ultimate terminal velocity is controlled by the ratio of flotation from the air-filled bladders to the amount of excess weight beyond the neutral buoyancy point. The larger this ratio, the longer the profiler

will loiter near the surface (i.e., initially fall slower) and the faster it will fall at depth (i.e., faster terminal velocity). It is the amount of additional weight acting against the air-filled bladders that provides the wide range of sampling strategies that can be applied to a wide range in water depths spanning very shallow coastal water to deep oceanographic stations.

Prior to the first full cast, make an abbreviated cast to confirm the profiler sinks at the desired rate and with near-zero vertical tilts. Lower the profiler to the surface and observe its behavior after releasing some cable. If the profiler immediately sinks, it probably has too much weight or too little flotation. Change the buoyancy with one or more of the following: a) adjust the desired number of air bladders or rigid flotation within the hydrobaric buoyancy chamber (Fig. 7l), which can hold a total of three; b) adjust the number of flotation disks below the hydrobaric buoyancy chamber (Fig. 7n); and c) adjust the desired amount of weight along the lower part of the backplane (Fig. 7p).

It may take one or more short casts to set the buoyancy. During the buoyancy adjustments, observe the pitch and roll readings of the profiler. If either or both show a bias, note the sign and magnitude, and apply the opposite as a correction using the conventions in Fig. 22.

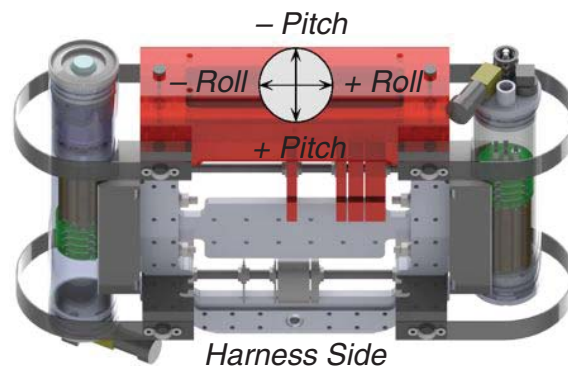

**Fig. 22.** The directionality of the pitch and roll axes on the C-OPS backplane (note the orientation is with respect to the side with the harness, wherein the  $E_d$  instrument is on the left and  $L_u$  instrument is on the right).

For example, if the profiler has positive roll bias, the radiance aperture is lower than it should be and the irradiance aperture is higher. The problem can be corrected by moving the flotation disks (Fig. 7n) towards the radiance instrument or moving the weights (Fig. 7p) towards the irradiance instrument. There are locking nuts on the shaft mounting the flotation disks and the weights that must be loosened and then retightened. Some experimentation and practice will be needed to determine how much lateral motion is needed for either correction approach.

Pitch bias takes a little more time to correct than roll bias, because both of the instruments must be repositioned. The nuts that secure the v-blocks to the backplane must be loosened and the v-blocks rotated in the desired direction.



The plastic caliper should be used to verify both v-blocks are rotated the same amount. This is done by measuring the offset of the v-blocks with respect to the backplane are the same at a common reference (e.g., the bottom edge of the v-blocks where the displacement is the greatest).

- **Exercise 7.5.2** *If the maximum range of adjustable tilt in a particular direction has been achieved, but more tilt adjustment in that direction is needed, what can be done to provide the needed adjustment?*

### 7.5.3 Executing a Cast

Lower the profiler into the water using a hand-over-hand motion (Fig. 23), which ensures one hand is always gripping the cable. It is tempting to let the cable slide through the hands, but this is a more uncontrolled procedure and should be avoided. When aboard medium- and large-sized vessels, it is important to initially place the profiler as far away from the vessel as possible, so surface waves cannot push it against the hull and cause damage.



**Fig. 23.** Lowering the C-OPS over the side of the R/V *Hakuho Maru* with a hand-over-hand motion.

If the distance to the water is relatively small, 10 ft (3 m) or less, the profiler can be tossed into the water. In this case, an effort should be made to *knife* the profiler into the water so it enters along the bottom edge (Fig. 24), rather than on the front or back of the backplane (which is reminiscent of a belly-flop). If the distance to the water is more than 10 ft (3 m), it is advisable to stand on a side of the vessel at the stern and lower the profiler half way to the surface. The profiler can be carefully swung side to side with the top of the profiler facing aft and perpendicular to the vessel. If the profiler is released at the height of the swing towards the stern, with a bit of practice, it will knife into the water along the bottom edge.



**Fig. 24.** Knifing the C-OPS backplane into the propeller turbulence aboard the R/V *SRV-X* in the Chesapeake Bay.

Once the profiler is in the water, a current acting on the ship or profiler, or the wind and waves acting on the ship, will increase the distance between the profiler and the ship. Consequently, it is advisable to use the wind, waves, and current to advantage, i.e., deploy the profiler on the side of the ship wherein the wind, waves, or current will move the vessel away from the profiler. If this is not possible, an effective way to move the profiler away from the ship is to position it at the surface and behind the ship's propeller(s). A short burst of thrust to the propeller will create enough turbulence to push the profiler far away. For larger ships, a thruster can serve the same purpose, and can allow the profiler to be deployed further forward on the vessel if equipped with a bow thruster.

- **Exercise 7.5.3** *What is the disadvantage in using propeller or thruster turbulence to move a profiler away from the ship?*

Although the data acquisition computer operator can observe when the profiler is in the water, the deck operator should provide a timely update when the profiler is sufficiently far away from the platform and if sky and sea conditions are forecast to be satisfactory so the cast can be executed. This communication should also make it clear if the deck operator requires any more time before beginning, and the computer operator should do the same. An example exchange, following the call signs established in Sect. 7.1.3, would be as follows:

Deck: "Lab, Deck; C-OPS in position with stable sea and sky conditions, Over."

Lab: "Deck, Lab; Roger, awaiting your drop command, Over."

Deck: "Lab, Deck; drop, drop drop, Over."

Lab: "Deck, Lab; Roger that, Over."

Deck: "Lab, Deck; standing by."

In this case, the deck operator ends the conversation by saying that a future response from the computer operator

is expected, in this case, it is the command to terminate the cast and start hauling in the profiler. The computer operator should log the cast number, the start time, the geolocation coordinates, and the sky conditions.

An important aspect for collecting good data with a free-fall system is to prevent the power-telemetry cable from coming under tension, because even brief periods of tension can adversely affect the vertical orientation (tilt) and velocity of the profiler. To ensure this does not occur, a coil or two of extra cable should be at the surface as the profiler sinks. A tangle-free and continuous feed of cable into the water is also needed, so an extra portion of cable that exceeds what is going over the side (3–5 coils) should be continuously removed from the bucket and *flaked* onto the deck to minimize the chance for cable entanglements.

When dispensing cable during profiling, a fair lead is established between the cable bucket and the point where the cable goes over the side of the ship (Fig. 21). To maintain the fair lead, the cable is pulled from the bucket using two hands. One hand pulls the cable out of the bucket using a back-and-forth motion, while the other is used to grip the cable and remove any snarls. If this is done, the figure-eight method provides a smooth delivery of cable during handheld profiling.

The termination depth of a profile is determined by the science objectives and the water depth. It is advisable to descend to at least the 10% light level, because this ensures near-surface data products can be produced and deeper ones can frequently be estimated. If this is not possible, because the water depth is less than the 10% light level, then there is likely to be a significant bottom contribution to the water-leaving radiance and additional corrections will be needed for the data products. To obtain a comprehensive description of the optical properties of the water column, it is advisable to profile to the depth of the 1% light level or the depth of the chlorophyll maximum (whichever is deepest). If the water depth is deeper than or on the order of the 1% light level, bottom contributions to the water-leaving radiance will be negligible.

Once the termination depth is reached, the data acquisition operator notifies the deck operator who immediately begins hauling in on the C-OPS sea cable. Meanwhile, the computer operator watches the depth and velocity display, and as soon as the profiler reverses direction, which usually also corresponds to an increase in vertical tilts, data acquisition is stopped and the stop time logged. A typical exchange between the two operators is as follows:

Lab: “Deck, Lab; bring it up, bring it up, Over.”

Deck: “Lab, Deck; Roger, bringing it up.”

Note that the computer operator repeats the command to establish priority and the deck operator leaves the conversation open.

Because the C-OPS backplane is kite shaped, it has a tendency to maintain a somewhat vertical orientation in the water column when the cable is hauled in. This

means the profiler is frequently well positioned, in terms of vertical orientation, when it reaches the sea surface (Fig. 25). Consequently, it is frequently easy to immediately begin another cast once the profiler is at the surface.



**Fig. 25.** The C-OPS profiler being hauled in aboard the Arctic Survey Boat (ASB) launched from the USCGC *Healy*.

If the profiler is too far away or too close to the platform, after it is hauled to the surface, it will have to be repositioned before the new cast is started (as already discussed in Sect. 7.5). In general, it is advisable to keep the profiler 10–50 m away from the platform, with the lower range used for small platforms and the upper range used for large platforms. In situations wherein windage acts upon the vessel to move it away from the profiler, it is likely that the profiler will come to the surface much farther from the ship than desired, so it will need to be hauled in to conserve cable for profiling.

Another important aspect for collecting good data with a free-fall system like C-OPS is to keep a close watch on the sky conditions around the Sun. Although the data acquisition computer operator can monitor the stability of the solar flux, this person cannot usually forecast when conditions will deteriorate, and if they are already unsuitable, when conditions will improve (an exception is on small platforms, e.g., small-boat operations). All forecasting requires an observer, which means the sky around the Sun must be periodically observed to understand trends and predict changes.

Although the deck operator is the logical person to provide solar stability forecasts, both operators should share in this responsibility to the extent possible, so there is good situational awareness as to what is going on environmentally. Although the emphasis here is on the conditions around the solar disc, the opportunity should be taken to also observe the horizon for threatening weather.

 *The Sun is a very bright object, so viewing the sky around the Sun must be done with care, and it is advisable to occlude the solar disk with the hand and wear glasses with appropriate UV blocking, as shown in Fig. 26.*





**Fig. 26.** Observing the sky conditions around the Sun aboard the R/V *Hakuho Maru*, while occluding the solar disk with a hand and wearing glasses with UV blocking.

When the termination depth is reached for the last cast that is to be executed, the exchange between the computer operator and the deck operator should make that clear, as follows:

Lab: “Deck, Lab; bring it on board, bring it on board, Over.”

Deck: “Lab, Deck; Roger, bringing it on board, Over.”

Again, Lab repeats the termination command to establish priority.

At this time, if the BioSHADE accessory is being used, a BioSHADE cast would typically be collected while the profiler is hauled to the surface, in which case the communications would continue as follows:

Lab: “Deck, Lab; acquiring BioSHADE, Over.”

Deck: “Lab, Deck; Roger.”

Once the profiler has been retrieved and stowed, the communications would usually continue as follows:

Deck: “Lab, Deck; profiler on board, Over.”

Lab: “Deck, Lab; Roger, standing by for the water sample, Over.”

Deck: “Lab, Deck; taking the water sample now, Over.”

Lab: “Deck, Lab; Roger, Over.”

Deck: “Lab, Deck; water sample completed, Out.”

It is common that water sampling occurs after a certain number of optical casts (usually three), so this exchange has been added to the conversation for completeness. Under normal circumstances Deck tells Lab when the sample is taken, so Lab can enter the time and geolocation into the written log.

## 8. TEST RECOVERY

With the BioSCAN frame there is no recovery per se. Once the desired number of observations have been collected, the frame needs to be stowed to complete the data acquisition event. The C-OPS in-water subsystem, however, requires a separate more complicated recovery operation and subsequently it must be stowed. Both the BioSCAN and C-OPS require the reference to be stowed when data acquisition is completed. All these functions are described in the following three sections.

► **Exercise 8.0** *Are there circumstances wherein the safest place for the backplane is at depth, i.e., it should not be recovered?*

### 8.1 Stowing the BioSCAN Frame

To stow the BioSCAN frame, the azimuthal collet is loosened with a  $\frac{5}{32}$  (hexagonal) ball-point driver, and the instruments are rotated until they are facing the operator, i.e., towards the deployment platform. The instruments are capped, and the collet is tightened (Fig. 27). This protects the instruments from weather coming towards the platform and, if on a ship, wave spray coming over the bow (assuming a preferred mounting on the bow).

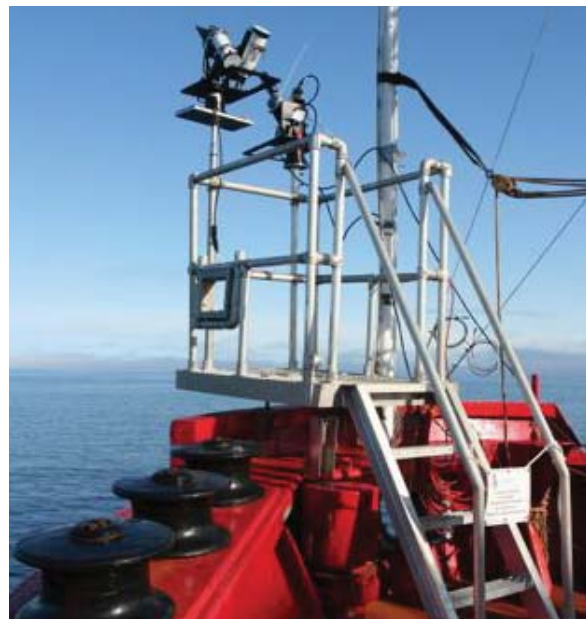

**Fig. 27.** An earlier version of the BioSCAN frame in the stowed position aboard the Canadian Coast Guard Ship (CCGS) *Amundsen* with the instruments capped and pointed inward.

► **Exercise 8.1** *How should the BioSCAN frame be stowed if severe weather is anticipated?*

### 8.2 Recovering and Stowing C-OPS

Recovering C-OPS is essentially a reversal of deploying it. Once the profiler is hauled in close to the ship,

a hand-over-hand motion is used to lift the backplane up and over the gunwale (Fig. 28). Shortly after recovery, the equipment should be rinsed with freshwater making sure to force the water into all crevices and orifices, to the extent practicable. The optical apertures should be blotted dry and the caps affixed. The profiler should then be placed in its storage basket.



**Fig. 28.** Recovering C-OPS aboard the R/V *Gulf Challenger* in the Piscataqua River.

- **Exercise 8.2** *If severe weather is expected, how should the C-OPS backplane be stowed?*

### 8.3 Stowing the Solar Reference

If a BioMAST is being used, the mast should be retracted and the restraining rod put into place with the security pin affixed. The solar diffuser should be inspected. If the diffuser is not damaged, rinse it with freshwater and blot dry; if the diffuser is damaged, follow the procedures in Sect. 9.5. Because the reference is frequently mounted in a more remote part of the ship, a squirt bottle filled with fresh water can be used for the freshwater rinse. After the rinse, the diffuser should be blotted dry with a lint-free cloth or paper towel. Then the cap should be fastened to the irradiance instrument.

On very large platforms with difficult opportunities to mount a solar reference, e.g., an icebreaker that has a large box-like superstructure, it is advisable to use a large telescoping mast mounted on top of the bridge to deploy the solar reference (Fig. 29). If this is done, stowing the mast is a more complicated procedure, because the mast is retracted in two steps. The first step retracts the mast, and the second step breaks down the retracted mast, so the

instruments are easier to access and to ensure safety during severe weather (the instruments can be accessed with the telescoping components retracted, but this requires the use of a built-in ladder that might be difficult to use in bad weather).



**Fig. 29.** A Telescoping Mount for Advanced Solar Technologies (T-MAST), the precursor device to BioMAST, aboard the CCGS *Amundsen* which, when deployed, placed the solar references at the highest point on the ship.

- **Exercise 8.3** *How should the solar reference be stowed if severe weather is anticipated?*

## 9. MAINTENANCE

The most recurring and periodic maintenance activity involves almost no tools and this is the daily maintenance that must be performed while in the field. After a data acquisition event is completed (usually a set of three casts), all of the instrumentation and support frames should be rinsed with freshwater. This is particularly important for the C-OPS backplane, because it is immersed in seawater. If the instrument cannot be washed down soon after use, the apertures should be blotted dry with a lint-free cloth or paper towel.

⚠️ ⚠️ *The quartz window of a radiance instrument can stain if salt water is left to dry on it.*

Based on a visual inspection of the irradiance instrument teflon diffuser, it should be cleaned with soap and water or isopropyl alcohol, whenever there are visible particles or foreign matter on the diffuser.

 Do not use stronger solvents or abrasives to clean the radiance quartz window or the irradiance teflon diffuser, which can etch or scratch the surfaces and compromise the calibrated responsivity.

In addition to maintaining the instrument apertures, the freshwater rinse protects the anodized aluminum housings, which can pit if stored with salt water on them and this is not covered by the manufacturer's warranty and neither is aperture damage. After rinsing, the apertures should be blotted dry with a lint-free cloth or paper towel.

 Do not use a wiping or swirling motion to dry an aperture, because if there is a rough particle left on the aperture, the wiping or swirling motion can cause scratching.

Once the apertures are clean and dry, they should be immediately protected by putting on the caps.

Longer-term maintenance procedures should also be pursued, wherein the instrumentation is returned to the manufacturer every 6–12 mos for calibration, inspection, and service. If field campaigns are conducted frequently or if the objective of the fieldwork is to support calibration and validation activities, the 6 mo calibration interval is recommended. As part of a calibration, the manufacturer will provide a standard evaluation of all components, O-ring service, and calibration of the optical instruments. On at least an annual basis, the pressure transducer, temperature probe, and tilt sensors should all be calibrated. If additional accessories are being used, e.g., BioSHADE and BioGPS, these should also be inspected.

Periodic intercomparisons with a different group or instrument system are recommended within every 5 yr or less. These types of exercises not only validate the capabilities of the instrumentation, but also the data processing and protocols being used. There are many types of uncertainties that can be exposed through intercomparisons, especially biases (e.g., the misapplication of a correction in two different parts of the data processing procedure). Example intercomparisons for both above- and in-water instrument systems are presented in Fig. 30.

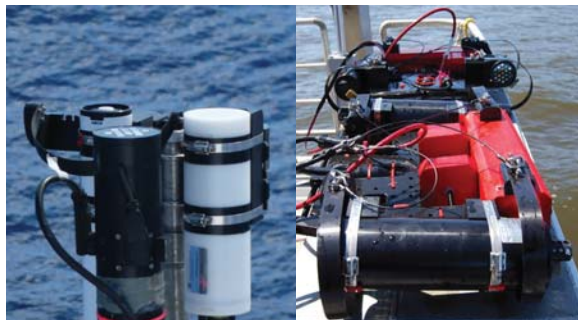

**Fig. 30.** The intercomparison of above- and in-water instruments as follows: two solar references aboard the R/V *Atlantic Explorer* (left), and the C-OPS and SuBOPS deployed from the R/V *Gulf Challenger* (right) within Great Bay, New Hampshire.

► **Exercise 9.0** If a cap is lost, what is a good substitute that can be obtained or fashioned in the field?

## 9.1 Maintenance and Minor Repair Tools

The tools discussed below are for common types of maintenance and repair—they are not intended for arbitrary problems requiring larger tool sets. This is not necessarily a concern when deploying on medium- and large-sized vessels, because they usually have technicians and an inventory of spare parts. On small platforms, spare parts are usually restricted to what is brought aboard, but the field campaigns are frequently day trips, which means spares can frequently be received as an overnight delivery.

The contents of the recommended maintenance and repair tool set is as follows:

- 1 ea Tool bag (color coded or labeled);
- 1 ea Multi-tool with all locking blades and tools constructed of 100% stainless steel, e.g., Leatherman Tool Group, Inc. model Wave (Portland, Oregon);
- 1 ea 6 in adjustable wrench;
- 1 ea 6<sup>5</sup>/<sub>8</sub> in needle-nose pliers;
- 1 ea 6<sup>1</sup>/<sub>2</sub> in combination jaw slip-joint (two-position) pliers;
- 1 ea 10 in slip-joint pliers;
- 1 ea six-piece slotted and Phillips screwdriver set (with blade sizes for slotted narrow round <sup>3</sup>/<sub>16</sub> × 3 in, <sup>3</sup>/<sub>16</sub> × 6 in; slotted round <sup>1</sup>/<sub>4</sub> × 4 in, <sup>5</sup>/<sub>16</sub> × 6 in; and Phillips #1 × 3 in, #2 × 4 in);
- 1 ea Can of (oil-free) compressed air with nozzle;
- 1 pk Lint-free paper towels or cloths;
- 1 ea 8 oz (237 mL) squirt bottle for freshwater;
- 1 ea Electrical coating 15 oz (444 mL) can (e.g., 3M Scotchkote);
- 1 ea Black, self-fusing, insulating putty in tape form (e.g., 3M Scotchfil Electrical Insulation Putty);
- 1 ea Conformable (to −18°C) rubber self-fusing tape (e.g., Scotch 23);
- 1 ea Conformable (to −18°C) rubber electrical splicing tape (e.g., Scotch 130C);
- 1 ea All weather, heavy duty, abrasion resistant, black vinyl electrical tape (e.g., Scotch Super 88);
- 1 pk Assorted sizes of heat-shrink tubing spanning <sup>1</sup>/<sub>32</sub>–<sup>1</sup>/<sub>2</sub> in diameters.;
- 1 ea Handheld soldering iron with lead-free solder;
- 1 ea Handheld voltmeter; and
- 2 ea 1.5 ft (0.5 m) red and black 18 AWG wire with small alligator clips at the ends.

The diversity of tapes above reflects their intended uses, and it is important to use the right tape for the right conditions. The example Scotch vinyl tapes discussed in this



document, i.e., Scotch 35 and Super 88, provide protective jacketing, electrical insulation, identification and color coding, as well as harness and bundling. These tapes are rated for cold-weather applications of 0°F (−18°C) and high-temperature environments of 221°F (105°C).

Rubber tapes provide electrical insulation, waterproof sealing, mechanical padding, and shaping. The temperature ratings for the Scotch rubber tapes discussed above are as follows: Scotch 23 and 130C are rated for 194°F (90°C) continuous and 266°F (130°C) short-term exposure, and Scotchfil is rated for 176°F (80°C).

Vinyl electrical tape is used the most often and is relatively straightforward to apply. A safe and reliable protocol for its use is as follows:

1. Apply tape with enough stretch (pulling force) to conform to the object(s) being wrapped.

 *Relax the amount of stretching on the last 2–3 in before tabbing it down to prevent unwinding (also called flagging, because the unwound end resembles a flag).*

2. Wrap cone-shaped splices *uphill*—that is, from the smallest to the largest point, thereby always securing the previous layer.
3. Wrap an irregular connection with rubber or mastic tape.

 *Pad all sharp edges before over wrapping with vinyl electrical tape.*

4. Keep fingers close together when tearing tape.

 *The farther fingers are apart when tearing, the more the tape will stretch before it tears, which can lead to flagging.*

5. Always use a minimum of two half-lapped layers.

 *The last layer should be wrapped in a more relaxed manner to prevent the layer from flagging.*

6. For short-term use with anticipated disassembly, fold the torn end under to leave a flag for easy removal.

Rubber tape is used as a build-up compound on irregular surfaces to pad sharp edges and provide a smooth taping surface. For example, to replace insulation removed for a splice, rubber tape is used to build up the section with missing insulation. Scotchfil putty is soft and pliable—simply press the putty into place, mold with finger pressure, and over tape using standard methods. Rubber self-fusing tape is designed to achieve a waterproof seal of a splice, particularly for cable with a neoprene outer jacket. For this application, all surfaces must be clean (use alcohol saturated pads to remove dirt and oils).

► **Exercise 9.1** *What is another name for self-fusing tape?*

## 9.2 Spares Inventory

The number and types of spares taken into the field is a function of the remoteness of the sampling location(s), the harshness of the anticipated environment, the duration of the field campaign, the fragility of certain components, and the age of the equipment being deployed.

The perspective adopted here is that field campaigns are rather expensive and the data is sufficiently precious that all deployments should include a spares inventory. Field campaigns are complicated affairs, so problems are inevitable. The objective of the spares inventory is to be prepared for likely problems. Upon receipt of the instrumentation from the manufacturer, a so-called *enhanced* spares inventory is recommended. These spares are simple additions to the tool set supplied by the manufacturer, which also contains some useful spares.

For more complicated, but nonetheless relatively short, campaigns close to the home institute, or deployments in areas with good overnight service possibilities, a *standard* spares inventory, that builds upon the enhanced inventory, is suggested. The standard inventory supports deployments on larger or more complicated platforms wherein additional flexibility in mobilizing the equipment is needed. For remote campaigns or sampling conducted with older equipment, an *extended* spares inventory is recommended.

As the spares inventory is built up, it is inevitable that the items will not fit into one of the original containers from the manufacturer, so additional container space is needed. It is important to note that the information regarding spares is simply advisory. It is expected that each researcher will make an informed decision as to what spares are appropriate based on available resources and science objectives. In some cases, a spare might simply be having access to another piece of equipment that is part of the campaign and is available at no conflict when the optical sampling requires it (e.g., a spare computer).

► **Exercise 9.2** *Why is containerizing spares and tools important to successful problem solving?*

### 9.2.1 BioSCAN Spares Inventory

The BioSCAN tools, which are supplied with the frame, are the starting point for establishing a BioSCAN spares inventory. It is intended to facilitate trimming and maintaining the frame and should contain the following spare components and tools (some items are in addition to what is provided by the manufacturer):

- 3 ea Mated six-contact SubConn micro dummy plugs with mated locking sleeves, i.e., three male and three female;
- 1 ea Small, resealable plastic container of Molykote 44 lubrication;
- 1 ea  $\frac{5}{32}$  in and  $\frac{3}{16}$  in (hexagonal) ball-point drivers for loosening and tightening cap screws;



- 1 ea Solar compass vertical rod;
- 1 ea Triangular angle set (40° and 45°) for setting instrument viewing angles;
- 1 ea Oval head stainless steel diagonal cutters;
- 1 ea Kestrel 1000 handheld wind speed meter (Nielsen-Kellerman, Boothwyn, Pennsylvania);
- 1 ea 6 in (15 cm) spirit level; and
- 1 ea Scotch Super 88 8.5 mil vinyl electrical tape.

► **Exercise 9.2.1** *Why is it desirable that certain tools appear in more than one tool inventory?*

### 9.2.2 C-OPS Spares Inventory

The C-OPS orange waterproof toolbox is supplied with the instrumentation and is the starting point for establishing a C-OPS spares inventory. It is intended to facilitate trimming and maintaining the profiler and contains the following components and tools (some items are in addition to what is provided by the manufacturer):

- 3 ea Mated six-contact SubConn micro dummy plugs with mated locking sleeves, i.e., three male and three female;
- 1 ea Small, resealable plastic container of Molykote 44 lubrication;
- 6 ea Slotted floats (two widths);
- 3 ea Long rectangular floats for hydrobaric buoyancy control;
- 3 ea Plastic air-filled bladders for hydrobaric buoyancy control;
- 7 ea Slotted weights (three sizes) for trimming the roll axis and buoyancy of C-OPS;
- 2 ea Nut drivers ( $1/4$  in and  $9/32$  in) for loosening and tightening hose clamps and backplane nuts;
- 2 ea  $1/2$  in open end wrenches for loosening and tightening weight and flotation nuts plus pitch adjustment nuts;
- 1 pk Small 6 in (15.2 cm) black cable ties for securing cable to the backplane;
- 1 pk Small 4 in (10.2 cm) cable ties for securing shackle pins;
- 1 ea Oval head stainless steel diagonal cutter;
- 1 ea Scotch Super 88 8.5 mil vinyl electrical tape; and
- 1 ea Plastic caliper and metal ruler for use as a reference when making mechanical adjustments.

Note that the cable ties are in addition to the inventory provided with the tape and cable ties tool bag (Sect. 6.1).

► **Exercise 9.2.2** *How is a small cable tie used to secure a shackle pin?*

### 9.2.3 Standard Spares Inventory

The standard spares inventory is designed to be applicable to both the BioSCAN and C-OPS instrumentation. The list of equipment is anticipated for common problems that experience has shown are likely to be encountered by first practitioners and seasoned field scientists alike. The recommend parts are as follows:

- 3 ea Waterproof marine R/T radios (one voice activated for hands-free deck operations, if possible);
- 1 ea 500–700 VA UPS;
- 1 ea 25 ft (7.6 m) grounded extension cord;
- 1 ea Surge protected power strip with on-off switch;
- 2 ea Dark cap screw (black nylon  $1/4$ -20 thumb screw with shoulder  $1/2$  in long);
- 1 ea Dark cap;
- 1 ea Handheld GPS;
- 1 ea Handheld low-speed anemometer (Kestrel 1000, Nielsen-Kellerman, Boothwyn, Pennsylvania);
- 2 ea 5 m adapter cable (MP/FG and FS/FG MCIL6 connectors);
- 1 ea anti-corrosion lubricant, e.g., Break Free Cleaner Lubricant Preservative (CLP) 16 oz (474 mL) bottle (Safariland, Jacksonville, Florida); and
- 1 ea Spare data acquisition computer.

The spare computer can be a computer that is used for another task, but is available during optical data collection in the event it is needed. In anticipation for its role as a spare, all needed software should be loaded onto the computer and tested as part of mobilizing for the field campaign.

► **Exercise 9.2.3** *Why is a handheld GPS useful even if a BioGPS is part of the instrumentation?*

### 9.2.4 Enhanced Spares Inventory

The enhanced spares inventory is also designed to be applicable to both the BioSCAN and C-OPS instrumentation and is intended for deployments on larger or more complicated platforms wherein additional flexibility in mobilizing the equipment is needed. The recommend parts are as follows:

- 1 ea 25 m extension cable (MP/MR and FS/FG MCIL6 connectors);
- 2 ea 15 m extension cable (MP/MR and FS/FG MCIL6 connectors);
- 2 ea 5 m laboratory cable (MP/FG and FS/FG MCIL6 connectors);
- 1 ea 1 m serial extension cable;
- 1 ea Computer AC adapter;
- 1 ea Serial adapter dongle, e.g., Tripp-Lite (Chicago, Illinois) Keyspan Model USA-19HS;
- 1 pk AA batteries (handheld GPS); and
- 1 ea CR2032 coin cell battery (handheld wind meter).

- **Exercise 9.2.4** *If an underwater cable is damaged, why is it important to not deploy it to depth?*

### 9.2.5 Extended Spares Inventory

The extended spares inventory is anticipated for remote deployments wherein overnight service is not possible and spares on the deployment platform are expected to be limited. The recommend parts are as follows:

- 1 ea Deck box AC adapter;
- 1 ea Deck box logic board;
- 1 ea 25 m extension cable (MP/MR and FS/FG MCIL6 connectors);
- 1 ea Y-cable (one MP/MR and two FS/FG MCIL6 connectors);
- 1 ea MCIL6 mated *pigtail* cables (one MP/MR and one FS/FG);
- 1 ea Fast-setting (5 min), two-part epoxy in two single-plunger 1 oz (30 mL) tubes (e.g., Devcon 5 Minute Epoxy Gel, Riviera Beach, Florida); and
- 1 ea Slow-setting (4–6 hr), two-part epoxy in two separate 1 oz (30 mL) tubes (e.g., J-B Weld, Sulphur Springs, Texas).

The Y-cable and logic board should not be viewed as luxuries, because if either are damaged, there are no alternatives except to repair the damage (if possible). Although it might be possible to fashion a replacement cable from other spares, that option is unlikely for the logic board.

- **Exercise 9.2.5** *What is a cable pigtail?*

## 9.3 Routine Maintenance

The most important routine maintenance are those activities that can be accomplished on a daily basis.

- **Exercise 9.3** *Why are daily activities so important to routine maintenance?*

⚠ *Daily rinsing of the equipment with freshwater is recommended to the extent practicable, so corrosive salts are washed away as promptly as possible.*

⚠ ⚠ *For C-OPS, the optical apertures should be rinsed repeatedly with freshwater after every recovery, and the aperture surfaces blotted blotted dry with a lint-free cloth or paper towel.*

⚠ ⚠ ⚠ *If compressed air is used to clean or dry an aperture, especially a cosine collector, verify it does not contain any petroleum products, which are sometimes used as a propellant (e.g., butane).*

The body of the C-OPS backplane or the BioSCAN frame can air dry. After the apertures are dry, they should be inspected for damage (e.g., cuts or abrasion) and contamination (e.g., foreign particles or oils and rinsed again

if present). If no damage is detected, and no additional cleaning is needed, affix the caps to the apertures.

The remainder of this section documents those maintenance activities which cannot typically be performed on a daily basis, but are necessary for maintaining the equipment in a high state of functionality.

### 9.3.1 Maintaining the Reference Mount

Because it does not get submerged into the water and automatically rinsed with freshwater daily, the solar reference can get rather dirty, particularly on a ship. Although the forward progress of a vessel sweeps air over the instrumentation, which assists in preventing particles from settling on the cosine collector, this is not true during stations wherein the vessel usually stops. Once a ship is stopped, the relative direction of the wind and the hot stack gases determines the areas that will be subjected to soot deposition, which can be significant (Fig. 31).



**Fig. 31.** The solar reference irradiance instrument after 10 dy at sea aboard the TR/V *Oshoro Maru* in the Bering and Chukchi Seas during which the ambient wind exceeded 20 kts ( $37 \text{ km hr}^{-1}$ ).

The solar reference subsystem should be rinsed with freshwater as often as practicable (e.g., some large masts remain extended for as long as possible, because of the extra work of retracting them), but at least weekly. Even at the top of a 60 ft (18 m) mast, there will be notable soot deposits if the cosine collectors are not cleaned on a regular cycle, because the hot stack gases buoy the particles to a high altitude. After the freshwater rinse, all surfaces should be wiped down to remove soot deposits, which can be corrosive. The diffuser should then be blotted dry with a lint-free cloth or paper towel, and immediately capped.

Fasteners that are rarely tightened or loosened should be removed on a periodic basis, e.g., at least once a year and preferably every 6 mos. The parts should be cleaned

in freshwater using a mild grease-removing soap, rinsed in freshwater, and air dried. If the threads of the fasteners enter a dissimilar metal, the threads should be greased with a small amount of Dow 111 and the parts reassembled. Any excess grease should be wiped away, and the affected area washed while being wiped clean. Any pipe fittings should be similarly cleaned and a stainless steel anti-seizing compound should be applied before reassembly. Again, any excess compound should be wiped away.

► **Exercise 9.3.1** *What other sources of airborne particulates can be deposited on the solar reference aperture?*

### 9.3.2 Maintaining the C-OPS Backplane

In addition to the daily maintenance conducted while in the field (e.g., freshwater rinses and aperture drying), periodic maintenance is needed to keep the instrumentation in a high state of functionality. A useful schedule for periodic maintenance is to perform it well before the instrumentation is shipped for the fieldwork. If this is done, there will be sufficient time to deal with any unanticipated failures with the equipment. The following are recommended inspections as part of periodic maintenance:

- Check the four-point harness to ensure each clip is held with two pieces of threaded rod capped with nylon-insert nuts (tighten with a 1/4 in nut driver).
- Check the shackles securing the harness to the backplane (tighten with a pair of pliers).
- Check the hose clamps affixing the instruments to the v-blocks (tighten with a 9/32 in nut driver).
- Verify the offsets of the v-blocks with respect to the backplane are the same (set them both to the average of the two offsets and remember to evaluate the pitch angle the next time the profiler is deployed).
- Check the nuts securing the pitch adjustment for the v-blocks (tighten, but do not over tighten with a 1/2 in open end wrench, while taking care not to bend the insert).
- Check the knurled nuts holding the lid on to the hydrobaric buoyancy chamber (hand tighten, while taking care not to over tighten).
- Check the nuts holding the movable flotation disks and weights in place (tighten with a 1/2 in open end wrench, while taking care not to round the nuts over).
- Check the locking sleeves on all the cables and make sure they are hand tightened.

► **Exercise 9.3.2** *Why are threads that fasten dissimilar metals greased with Dow 111?*

### 9.3.3 Maintaining the BioSCAN Frame

Because the BioSCAN is usually mounted on the bow of a ship, it receives a significant amount of salt spray

from the forward motion of the vessel, breaking waves, and white caps. The BioSCAN frame and instruments should be rinsed with freshwater as often as practicable (e.g., on some large ships freshwater must be hand carried to the bow), but at least every 7 dy. After the freshwater rinse, all surfaces should be wiped down to remove salt deposits, which can be corrosive. The radiance apertures should then be blotted dry with a lint-free cloth or paper towel.

Fasteners that are rarely tightened or loosened should be periodically removed, e.g., at least once a year and preferably every 6 mos. The parts should be cleaned in freshwater using a mild grease-removing soap, rinsed in freshwater, and allowed to air dry. If the threads of the fasteners enter a dissimilar metal, the threads should be greased with a small amount of Dow 111 and the parts reassembled. Any excess grease should be wiped away, and the affected area washed while being wiped clean.

► **Exercise 9.3.3** *What are some cautions that must be observed when removing fasteners that have held fast for a long time without being tightened or loosened?*

## 9.4 Damaged Backplane or Frame

The C-OPS backplane is made with several synthetic components, whereas the BioSCAN frame is made almost entirely with metal. Nonetheless, both are very strong and not likely to be damaged under normal use. For example, Fig. 32 shows a long line of scientists and crew hauling in the C-OPS backplane against a strong current and the combined pulling tension of so many people had no negative effect on backplane components.



**Fig. 32.** A line of scientists and crew hauling in the C-OPS backplane against a strong current aboard the R/V *Hakuho Maru*.

A likely source of damage are impact strikes. For the C-OPS backplane, waves tossing the backplane against the deployment platform are a concern, as are waves coming up and over the BioSCAN frame. Whether or not sustained damage is repairable requires a case-by-case analysis that exceeds the objectives of this report. A possible type of damage to the C-OPS backplane that can be repaired, if all broken pieces are recovered, is damage to the red flotation, which can be reassembled with a two-part epoxy (e.g., 3M Scotch-Weld 1838).

A type of damage on the BioSCAN frame, or any other metal housing, that should be repaired promptly is if the

surface is scratched so deeply bare metal is exposed. In this case, the area should be thoroughly cleaned with freshwater, the area around the scratch should be masked off with tape, and the scratch similarly painted.

► **Exercise 9.4** *Why should scratched anodized aluminum be painted promptly?*

## 9.5 Damaged Optical Apertures

If an aperture shows evidence of contamination, the following procedures should be followed:

1. Log a description of the contamination and note the data acquisition events that might have been, or will be, negatively effected.
2. Rinse the aperture repeatedly with freshwater.
3. If the contamination persists, use more freshwater and light brushing strokes with a lint-free cloth or paper towel to try and remove the contamination; then rinse again with freshwater.
4. If the contamination appears *adhered* to the aperture, blot isopropyl alcohol against the contaminated area and use light brushing strokes with a lint-free cloth or paper towel, followed by a freshwater rinse.

 *Do not use any chemicals except isopropyl alcohol, and if compressed air is used, ensure it does not contain oils of any kind (some compressed air contains a hydrocarbon in the propellant).*

5. If the aperture remains contaminated, remove the instrument in question, apply the dummy plug(s), and immerse the sensor in freshwater for a long period of time (e.g., over night), and repeat steps 1–3.

If an aperture shows evidence of permanent damage (e.g., a scratch or stained area in the radiance quartz window, a scratch in the irradiance diffuser, etc.), the following procedures should be followed:

1. Log the observation(s) and note the data acquisition events that might have been negatively effected.
2. Take a picture of the aperture to record its present state as the new baseline as to what the aperture looks like.
3. After returning from the field campaign, request a return merchandise authorization (RMA) from the manufacturer, and provide a detailed description of what occurred in the field, including all cleaning attempts.

► **Exercise 9.5** *Why is a scratched aperture a concern?*

## 9.6 Power or Telemetry Integrity Faults

Troubleshooting a loss of power or telemetry integrity, because of a fault in instrument performance, inevitably leads to an investigation of the cables and connectors being used. If a visual inspection does not identify the problem, a common tool for further investigations is the voltmeter.

 *Many voltmeter probes are sufficiently large that they can splay female sockets, especially if the probes are firmly inserted into the socket at an awkward angle.*

An alternative practice for measuring signals on female sockets is to plug a spare male pigtail into the female connector and measure the desired signals from the stripped wires of the male pigtail.

► **Exercise 9.6** *What is another safe technique for measuring signals on female sockets?*

 *Using a secondary smaller probe or stripped wires with a voltmeter requires caution if the power must be applied to the cable to troubleshoot a fault condition, but is safe if the signal measurements are to determine continuity or obtain resistance readings, which can be accomplished with the power off.*

Troubleshooting a fault condition with a cable involves confirmation of proper pin-to-socket conductivity for the power and telemetry conductors (Sect. 4.2.), which means engineering drawings or wiring diagrams for the cables being used are required. In most cases, these are only available from the manufacturer. Figure 33 presents the BSI engineering drawing for an interface cable, which is one of the more common cables used in the field.

Although it may be possible to receive diagrams like Fig. 33 while at sea, there are frequently size limitations for attachments sent to research vessels. Consequently, it is advisable to have all cabling diagrams for the instrumentation before commencing field operations. For convenience, the other cable diagrams needed for HySEAS instruments (in addition to Fig. 33) are presented in Appendix F.

## 9.7 Repairing a Damaged Cable

Repairing a cable that has more than topical abrasion, i.e., it has been cut or crushed, will likely require splicing to remove the damaged area. In such a case, the cable is cut on both sides sufficiently far from the damaged area such that unequivocally undamaged conductors are present.

 *The sea cable should not be spliced except close to the MP/MR end, because no techniques exist to properly splice the kevlar strength member and, thus, ensure the cable will not part under load.*

If the sea cable is spliced at the MP/MR end, only a small length of cable, or pigtail, containing the MP/MR connector should be retained. After the splice is completed, brightly colored tape should be affixed to the splice to make it clear that the cable is compromised at that end.

Staggered splicing is advised because each splice lies against one or more unspliced neighbors and are protected by the original insulation of nearby conductors. Consequently, if there is a sharp edge from the splice (e.g., from solder) it is first covered with heat-shrink tubing, and then



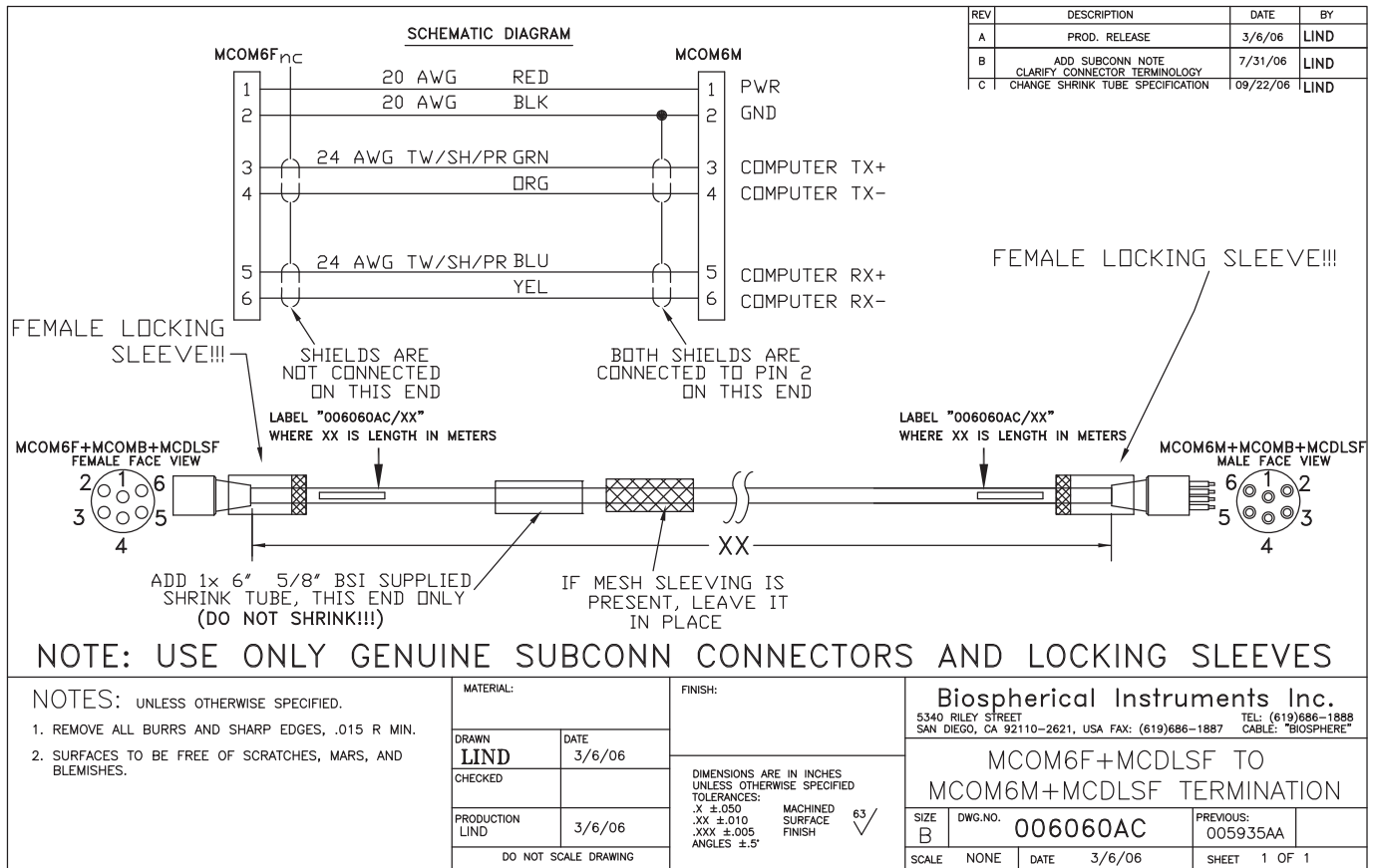

**Fig. 33.** An engineering drawing of an interface cable to be used with HySEAS instruments (e.g., the C-OPS or BioSCAN reference) divided into four parts (bottom to top):

- The title block (bottom) identifies (right to left) the firm (Biospherical Instruments Inc.) with their contact information; the name of the work piece MCOM6F+MCDLSF to MCOM6M+MCDLSF TERMINATION, wherein the terminology used is provided by the manufacturer (MCOM is a micro connector for over molding, 6F is six female sockets, 6M is six male pins, and MCDLSF is a micro connector delrin locking sleeve with female grooves); the drawing (paper) size (B), number (006060AC), and previous version (005935AA); finish, dimensions, tolerances, and surface machining (radius of 63 μm); material, drawing author with date, and scaling; plus assembly notes and a clear requirement to **USE ONLY GENUINE SUBCONN CONNECTORS AND LOCKING SLEEVES**.
- The detailed drawing (middle) of the assembled cable showing the connector faces with pin (right) and socket (left) face views; the presence of the locking sleeves; applied labels to both ends (006060AC/XX, where XX is the length of the cable in meters between the connector ends); the requirement to leave (a chinese finger) mesh in place, if present; and to add one 6 in long piece of 5/8 in shrink tube to the socket end, in case a chafe guard is needed (so it is not shrunk into place).
- The schematic diagram (top left and center) specifying straight-through pin-to-socket assignments wherein (right to left) PWR is power, GND is ground (or common), TX+ is transmit positive (voltage), TX- is transmit negative (voltage), RX+ is receive positive (voltage), RX- is receive negative (voltage), RED is red, BLK is black, GRN is green, ORG is orange, BLU is blue, YEL is yellow, AWG is American wire gauge†, TW/SH/PR is twisted shielded pair, and nc indicates no connection.
- The version control block (top right) shows when the original (REV. A) was established and by whom, and all subsequent new versions (B and C) with a description of what changed for the new versions.

† A 20 AWG wire has a diameter of 0.0320 in (0.812 mm) and a 24 AWG wire has a diameter of 0.0201 in (0.511 mm), so smaller AWG wire numbers are larger in cross-sectional area and ampacity. The diameter in inches (millimeters) of a number  $n$  AWG wire is computed as  $d_n = 0.005 d_p$  ( $d_n = 0.127 d_p$ ), where the diameter proportionality term  $d_p = 92^{(36-n)/39}$ .

lies against the original insulation of the neighboring conductor(s) rather than another taped or heat-shrunk splice.

A partial representation of a staggered splice is provided diagrammatically in Fig. 34, wherein the heat shrink tubing that must be put on before the wires are joined is not shown for clarity. The top shows two wires exposed with a gray over jacket and stripped back with the bare conductors crossed. In the bottom, the bare conductors have been twisted together to create a mechanical bond of the conductors. They are then individually soldered and the heat-shrink tubing applied (the heat-shrink tubing must have been placed over the conductors before they were twisted and soldered).



**Fig. 34.** A schematic of a staggered splice with the ground wire and heat-shrink tubing omitted for clarity: the wires stripped back within the gray over jacket and the bare conductors laid across one another at angles (top), so they can be twisted together and soldered (bottom).

After the heat-shrink tubing is applied, the spliced conductors can be covered or *painted* with ScotchKote, making sure to get good coverage over all irregular surfaces. After 15 min of drying, the area between the gray over jacket is then built up with self-fusing rubber tape that is then extended outwards approximately 2 in (5 cm) from each end as a series of overlapping wraps. Finally, vinyl electrical tape is applied, again as a series of overlapping wraps to cover the rubber tape and provide an abrasive-resistant layer for protection.

Staggered splicing creates a slightly enlarged diameter over a longer span of the cable. Wherever two wires are soldered together, flexibility is compromised. Consequently, reinforcing ribs cut from cable ties can be added to provide strain relief over the extent of the splice, so the cable cannot be bent so much as to break the soldered joint.

► **Exercise 9.7** *What is a common mistake when applying heat-shrink tubing that must be avoided for splices that will be submerged to depth?*

## 10. SHIPPING

Sensitive equipment, like optical instruments, should be shipped in rigid-shell, reusable containers that are foam lined, preferably with custom inserts to keep the instruments from moving. Plastic boxes that cannot corrode with stainless steel hardware are preferred, because of the

frequency of deployments in the marine environment. The hardware should have multiple closing hasps that securely latch the lid to the bottom of the container.

The density and thickness of the foam lining should be selected based on the weight and fragility of the item(s) being packed. For general purposes, a 1 in (2.5 cm) rigid-foam lining is appropriate. If items requiring a less dense material are included, they should be over wrapped with the proper insulation. Another consideration is that fieldwork involves exposure to inclement weather during mobilization and demobilization, so containers and their contents can be wetted. Consequently, closed-cell foam lining with a sealed outer surface that can be wiped dry is preferred, because it prevents the retention of water, which could be salty.

⚠ ⚠ *Small pieces of insulation (e.g., so-called styrofoam peanuts) should not be used, because packing and unpacking on an open deck frequently means exposure to windy conditions that can blow the material into the harbor or out to sea, which is forbidden (Sect. 12.5).*

A critical aspect of successful packing is to ensure no voids allow the packed contents to move (Fig. 35). In some cases, this means filling voids with an insulating material, e.g., bubble wrap. An overlooked void is the top of the box. When closing a box that is presumed full, there should be mild resistance to the lid being closed; if not, insulating material should be used to fill the void.



**Fig. 35.** An improperly packed instrument sent to the manufacturer wherein loose packing material permitted the instrument to tumble inside the container and completely flatten a piece of bubble wrap insulating material (courtesy J. Morrow).

For long-distance and remote shipments, the most sensitive components should be packed using a box-within-a-box approach. For example the optical containers should

be packed inside a second container to further protect them. In some cases, this might not be feasible, because of restrictions in container size and weight for unique, usually remote locations. For example, sometimes the final cargo flight might be on a small propeller plane or a helicopter with small cargo hatches.

Another important aspect of successful packing is to ensure the over wrapped insulating material is held in place. For heavy and fragile items, like glassware, this might mean taping the insulating material to keep the heavier item from working its way out of the insulating material due to vibration. If glassware shakes free of the insulating material, it can come into contact with another hard object, like a second piece of glassware, and break.

It is advantageous to label the general contents of each box to facilitate mobilization, particularly if the time to do so will be short. It is also useful to have one box designated as being the first to be opened, so unpacking tools are immediately available. For example, if wooden crates are part of the shipment, it is advantageous to be able to access a cordless hex-drive impact driver to remove screws from the wooden boxes. Such a box should include large pliers or diagonal cutters for removing any banding applied to the containers (a very useful safety precaution).

► **Exercise 10.0** *How does labeling the contents of boxes aid demobilization?*

To facilitate return shipping, it is convenient to use plastic self-adhesive envelopes to hold the shipping labels. The label itself is a folded piece of paper with the address for going out to the field on one side and the return address on the other. To return the shipment, all that is required is the plastic envelope is opened, the piece of paper flipped over, and the plastic envelope resealed with clear tape.

## 11. STORAGE

There are two kinds of storage of interest here: a) short-term storage during a field campaign, and b) long-term storage between campaigns. During a campaign some equipment is stowed daily to keep it safe, e.g., the C-OPS backplane and sea cable. This equipment is used each day under varying conditions, so it is not practical to try and keep it dry between use. The objective should be to always rinse the equipment with freshwater after use and dry the optical apertures before the caps are put on. Under these circumstances, the equipment can be stowed wet.

The cable bucket is open to the atmosphere and if holes are drilled into the bottom it will drain, which means the cable will also mostly dry between deployments. The same is true for the profiler if it is stored in an open basket. If a container with a lid is used, which has the advantage of providing sun shielding, the lid should be kept slightly open so the contents can mostly dry between deployments.

Long-term storage presents opportunities for problems, because the containers are typically sealed shut.

 *Do not store equipment that is wet inside a sealed container for an appreciable amount of time—especially the optical instruments—because seawater can stain the radiance quartz window, significant corrosion can occur on metal parts, and the aluminum housing can pit.*

All equipment and the container plus insulating material used for holding and protecting the equipment must be completely dry for long-term storage. Because boxes that are stored for a long time can get moved around, the contents should be packed from the perspective as if they were being shipped (Sect. 10). Any solar shielding material, e.g., a white sheet, should be cleaned (laundered) and dried before being packed.

Cabling, which by definition gets wet, should be cleaned and air dried before it is stored. If the outer jacket is rough, it should be soaked in freshwater for approximately 1 hr to dissolve the salts in the over braid, and then cleaned with a mild grease-removing soap; if the outer jacket is smooth, it should be cleaned with a cable cleaner and degreaser or a mild grease-removing soap. After cleaning, the cable should be coiled into a container, a large diameter line passed through the center, and the coil hung to dry.

The C-OPS backplane and the BioSCAN frame should be rinsed with freshwater, cleaned with a mild grease-removing soap, and then rinsed repeatedly with freshwater. The backplane and frame should be dried on both sides. It is important to open up the C-OPS hydrobaric buoyancy chamber and make sure it and the contents are cleaned and then fully dry before reassembly. For the BioSCAN frame, the collet and azimuthal band components should be rinsed with freshwater several times.

The solar reference, BioGPS, and BioSHADE should be cleaned and rinsed as a unit. It is important to use freshwater to clean out the pivot points for the shadow band with running freshwater and to force freshwater into all areas where salt can accumulate. After repeated freshwater rinses, the unit should be allowed to air dry.

If used, the BioMAST should be cleaned with a mild grease-removing soap and repeatedly rinsed with freshwater. It is important to force water into all the gear and cable pathways to dissolve and remove any salt accumulation. The stainless steel winch should be operated back and forth with freshwater running over the moving parts. All components must be allowed to dry before the mast is packed into its shipping crate.

During inclement weather, it may be necessary to take equipment indoors to air dry. If this occurs during demobilization on a ship, it will strain the schedule, so the cleaning and drying tasks might need to be started earlier than initially planned.

► **Exercise 11.0** *What other activity should be synchronized with long-term storage?*

## 12. SMALL-BOAT OPERATIONS

Small-boat operations can be undertaken from a large vessel by simply launching a smaller one (Fig. 36). Frequently, and just as effectively, small-boat operations are conducted by trailering a small boat to a sampling site. This approach can add new dimensions to data acquisition in near-coastal shallow waters. Small-boat operations are particularly well suited for field campaigns to lakes, reservoirs, rivers, bays, and estuaries.



**Fig. 36.** The small boat or *barge* launched from the CCGS *Amundsen* wherein the smaller vessel could drift into sea ice areas with minimum mixing of the water mass to be sampled.

Trailering provides flexible exploration of shallow-water ecosystems, because a trailer allows economical boat storage between expeditions to a diversity of sites that might not otherwise be connected by waterways (as opposed to renting a boat at each site, which might not be possible). This approach provides the advantage that the boat need only be outfitted once, which can be a big time saver, particularly in comparison to establishing a mount for the solar reference on a variety of vessels.

The operator is responsible for understanding the restrictions, regulations, and safety precautions for using a small boat for scientific research. A paramount concern is safety, which is a function of properly preparing for the known aspects of a field campaign and then acting responsibly to unknowns, e.g., changes in weather.

 *High winds can lead to a small craft advisory, whereupon, as a safety precaution, boat ramps should not be used to launch a boat and are frequently closed, although they can be used to retrieve a boat.*

In the U.S., a small craft advisory is issued by the National Weather Service when winds have reached, or are expected to reach within 12 hr, a speed of nearly gale force. The wind speed warning encompasses the combined ranges of forces 6 and 7 on the Beaufort scale, which is 22–33 kts (about 11–17  $\text{ms}^{-1}$ ) and seas 10 ft (3 m) or greater. For the purposes of the advisory, a small craft is typically a vessel with an overall length less than 65 ft (about 20 m). Inexperienced mariners, especially those operating small craft, should avoid navigating in these conditions.

For the shallow estuaries, rivers, and lakes anticipated here for small-boat operations, the remainder of the material presented is based on a more restrictive definition of a small boat and its intended operations as follows:

*A small-boat operation uses a vessel less than 23 ft (7 m) long with an outboard motor and portable gas tank that is manned by adults during good visibility and daylight hours in navigable U.S. waters.*

For determining the length of the boat, the distance is measured from end to end, over the deck, excluding sheer. This means a straight line measurement of the overall length from the foremost part of the vessel to the aftermost part of the vessel, measured parallel to the centerline (bowsprits, bumpkins, rudders, outboard motors, brackets, attached diving platforms, and similar fittings or attachments are not included in the measurement).

The requirements to safely operate or *handle* a small boat are significant. Even with the more restrictive definition of a small boat given above, the amount of detail needed to convey all this topic entails is beyond the scope of this document. Consequently, only a few of the most important topics are provided as a means to motivate the practitioner to seek the proper training and information†.

In the U.S., a boat is required to be registered in the state of principal operation. The registration must be available for inspection at all times when the vessel is in use and the boat registration numbers must be displayed on the forward half of the vessel. The numbers must be painted or permanently attached with state validation stickers, when required, affixed within six inches of the registration number (state requirements may vary).

► **Exercise 12.0** *Why are the limits and cautions of a small craft advisory useful to understand even on a large deployment platform?*

### 12.1 Trailering

The trailer is an important part of small-boat operations and the National Marine Manufacturers Association (NMMA) has a trailer certification program to assist boat trailer manufacturers in the U.S. comply with established industry standards and federal safety regulations. This program benefits the public by ensuring a trailer with NMMA certification that is purchased or rented is compliant in regards to identification plates, capacity ratings, couplings, safety chains, lighting, winches, brakes, registration, and conspicuity. A manufacturer participating in the NMMA program certifies all model years are fitted with factory-supplied equipment, and inspectors visit the manufacturer and inspect each trailer model for compliance to all certification standards.

† In the U.S., to find a boating course near the practitioner's location, visit [www.boatus.com/foundation](http://www.boatus.com/foundation) or contact a local Coast Guard auxiliary.



There are several elements that need to be considered to trailer a boat. The first is the towing capacity of the vehicle to be used. This information is in the vehicle owner's manual. Sedans are generally not suitable for towing. Most standard pick-ups, large sports utility vehicles (SUVs), and small 10–12 ft (3.0–3.7 m) box trucks, however, can trailer boats that are 25 ft (8 m) in length or less.

If the vehicle has the requisite towing capacity, there are two types of weight that are important to towing: the tongue weight and the towing weight. The tongue weight sets the downward weight limit on the trailer tongue, and the towing weight sets the horizontal limit. The tongue weight is always a small fraction (about 10%) of the total tow weight and requires adherence to sensible balancing of the boat on the trailer, as well as paying attention to the height of the tow ball with respect to the frame height of the trailer. The trailer is also designed to be towed with a tow ball of a specific size, e.g., 1 7/8 in.

 *Do not attempt to tow a trailer with a vehicle that does not have the towing capacity for the weight of the trailer being towed, as well as the necessary ratings in terms of the trailer tongue weight and towing weight, the size of the tow ball, and the height of the tow ball above the ground.*

In general, as the weight, length, and beam of a boat increase, the difficulty in launching and retrieving it increases. For small boats as defined here—less than 23 ft (7 m) in length—they may all be safely handled by one person in the vehicle and one person at the ramp. From the perspective of conducting sampling on the water, three people are preferred: one to handle the boat, one to deploy and recover the instrumentation, and one to operate the data acquisition software.

Trailing laws vary from jurisdiction to jurisdiction and often are based on weight and beam. The regulations that apply to the local jurisdiction where the fieldwork is occurring should be checked prior to commencing small-boat operations.

► **Exercise 12.1** *If the tow vehicle meets all trailering requirements except the tow ball is not at the correct height above the ground, what is a possible solution?*

## 12.2 Towing

Before attempting to tow a particular trailer and boat, the towing capacity of the intended vehicle and the towing hitch must be compared to the weight of the boat and trailer. The boat owner's manual lists the *dry weight* of the boat, which is the weight of the boat, without fuel, gear, and any modifications made after manufacturing. When assessing the towing capacity of the vehicle and hitch, it is advisable to add several hundred pounds to the dry weight of the boat to account for the extra equipment that will be added for the field campaign. The weight of the trailer

is usually provided on a specification plate affixed to the front of the trailer near, or as part of, the tongue.

The hitch on the tow vehicle must be rated for the anticipated weight of the fully loaded trailer. Hitch classes vary from Class I with a capacity of up to 2,000 lb gross trailer weight and 200 lb tongue weight, to Class V with a capacity greater than 10,000 lb gross trailer weight and 1,000–1,200 lb tongue weight. The hitch attaches directly to the tow vehicle and provides the physical connection between the tow vehicle and the trailer.

For the operations considered here, hitch installations are usually permanent and involve two types of hitches:

1. A fixed tongue hitch has a flat, non-removable drawbar; and
2. A receiver-style hitch has a square receptacle (usually 1 1/4 or 2 in) wherein a hitch bar is slid into the receptacle.

The hitch bar is designed to hold a hitch (or trailer) ball, as well as accessories. Recreational and light commercial hitch balls come in a variety of sizes, with 1 7/8 and 2 in being the most common.

The trailer coupler is the forward-most part of the trailer tongue. The coupler attaches to the hitch ball to secure the trailer on the tow vehicle, and articulates around the hitch ball during towing. The size stamped on the ball must be the same size stamped on the coupler. If the ball is too small, a bump in the road could cause the coupler to lift off the hitch.

A release mechanism on top of the coupler facilitates connecting the coupler to the hitch ball. Pull up on the coupler latch to fit the coupler onto the ball and then release the latch. Lift up on the trailer tongue to verify the coupler is properly engaged and does not lift off the ball. There is also a hole in the mechanism to accept a safety pin, so the release mechanism cannot accidentally engage.

The hitch also contains receptacles for safety chains. The chains are attached to the trailer tongue and have hooks on their free ends to attach to the hitch (Fig. 37). The chains keep the trailer connected to the tow vehicle should the coupler or hitch ball detach from the tow vehicle.



**Fig. 37.** A partial view of a trailer attached to a hitch, showing the coupler attached to the hitch ball on a receiver with crisscrossed safety chains attached below (<http://www.boat-ed.com>).

 Once a suitable vehicle-boat-trailer combination is selected, *the functionality of the trailer with the boat attached should be checked before towing as follows:*

1. The wiring harness attaches securely (perhaps with adapter) and all trailer lights work as intended;
2. The coupler functions and has the safety pin;
3. If a receiver is being used, the safety pin is present;
4. The hand winch securing the boat to the trailer works in both directions;
5. The front wheel winch works and the wheel rotates (this functionality can be invaluable during parking);
6. Both safety chains are crisscrossed under the coupler and in place;
7. The vessel is secured to the trailer with several tie-down straps to prevent shifting (do not trust the bow hand winch alone to hold the vessel onto the trailer);
8. The tow vehicle and trailer tires are properly inflated;
9. The lug nuts (or bolts) on the wheels of both the towing vehicle and the trailer are properly tightened;
10. The spare tire for both the vehicle and the trailer are in good shape and properly inflated; and
11. No safety equipment has visible signs of wear.

 *Replace any worn or questionable equipment as necessary and as soon as possible.*

A needed awareness for steering a vehicle while towing a trailer is the increased length, which means the vehicle-trailer combination requires more space to turn. In the U.S., this means righthand turns must be made wider than normal to prevent the trailer from hitting or bumping over the curb. Furthermore, if the tongue weight is too light, the trailer will tend to swing from side-to-side (or *fishtail*). If the tongue weight is too heavy, the rear wheels of the tow vehicle will be weighted down and make steering difficult.

Backing a vehicle with trailer can be challenging, because there is limited visibility around the boat and the trailer will move opposite the direction the tow vehicle is steered. For example, if the steering wheel is turned to the right (CW) while backing up, the trailer will move to the left side of the tow vehicle (and vice versa).

Many hotels do not have parking areas to accommodate a vehicle-trailer combination, so the trailer might need to be detached from the tow vehicle and parked separately by manually moving the trailer into the parking space using the front wheel winch. If the trailer is removed for parking, remember to use the appropriate locks and if a receiver-style hitch is used to disconnect the receiver and stow it in the tow vehicle with the safety pin.

► **Exercise 12.2** *If the vehicle mirrors are used for backing up a trailer, what precaution should be followed in regards to steering the vehicle?*

For trailer security, a wheel lock and a coupler lock are advisable. A wheel lock is usually a hardened steel cable with a lock. With the lock open, a free end is fed through the trailer wheel spokes and through the trailer frame; once the lock is engaged, the trailer cannot be moved. A coupler lock is a special lock designed to a) fit through the coupler latching mechanism when the trailer is hitched to the tow vehicle, or b) attach to the ball receptacle when the trailer is not hitched to the tow vehicle.

## 12.3 Equipping

Safety equipment is arguably the most important equipment loaded on the boat, some of which must be Coast Guard approved. The term “Coast Guard approved” is applied only to those items required by regulation to be in compliance with U.S. Coast Guard specifications.

 *For recreational boats of the type commonly used for the defined small-boat operations considered here, i.e., vessels less than 23 ft (7 m) in length with an outboard motor and portable gas tank that are operated and manned by adults during good visibility and daylight hours in navigable U.S. waters, the items of equipment that must be Coast Guard approved are as follows:*

1. Personal flotation devices (PFDs);
2. Fire extinguishers; and
3. Visual distress signals (VDSs).

In addition, the following equipment that might be carried aboard is as follows:

4. Sound producing devices;
5. Navigation lights; and
6. Recommended items.

► **Exercise 12.3** *What is one of the difficulties of using safety equipment on a small boat?*

### 12.3.1 PFDs

Aside from the capabilities of the boat operator, PFDs are usually the most important safety equipment on a boat, because they provide protection against drowning—a universal concern when working on a vessel.

 *To be effective, PFDs must be in serviceable condition, and correctly sized for the user.*

There are six types of Coast Guard approved PFDs. Type I, II, and III PFDs are designed to maintain a person in an orientation that is not face down. Type I PFDs are the most capable, but also the most cumbersome. Type II and III PFDs are intended for use in inland waters where there is a reasonable chance of a speedy rescue. Type IV are throwable devices and Type V are intended for special use activities, e.g., exposure suits and work vests. The inflatable recreational PFD is a sixth type and is more comfortable to wear, especially while working.

Following the axiom that *the best PFD is the one that is worn*, the inflatable PFD might seem a perfect choice. Unlike other types of PFDs, however, inflatables require the user to pay attention to the condition of the firing device (e.g., a CO<sub>2</sub> cylinder). Inflatable PFDs must have a full cylinder and all status indicators confirming functionality to satisfy the requirement for carrying this PFD.

Wearable PFDs must be readily accessible and available for immediate donning in an emergency (vessel sinking, fire on board, etc.) PFDs should not be stowed in plastic bags, in locked or closed compartments, or have other gear stowed on top of them. Throwable devices must be immediately available for use. Although not required, boaters should wear a PFD when a vessel is underway.

- **Exercise 12.3.1** *What common accident might render an inflatable PFD ineffective for the person wearing it?*

### 12.3.2 Fire Extinguishers

Fire extinguishers are only required on certain boats, but all must be specifically marked “Marine Type U.S. Coast Guard Approved.” Extinguishers are classified by a letter and a roman numeral. The letter indicates the type of fire the unit is designed to extinguish. Type B, for example, is designed to extinguish flammable liquids, e.g., gasoline, oil, and grease. The roman numeral indicates the relative size of the extinguisher (minimum extinguishing agent weight). The extinguishing agents include CO<sub>2</sub>, dry chemical, halon, or aqueous film-forming foam (AFFF).

- **Exercise 12.3.2** *Although designed for safety purposes, what are some hazards posed by fire extinguishers?*

### 12.3.3 VDSs

All vessels 16 ft (4.9 m) and over in length must be equipped with Coast Guard approved VDSs. Between the hours of sunset and sunrise all boats must carry on board a means of distress signaling suitable for night use. Floating and handheld orange smoke or an orange flag are suitable for day use. A handheld flare, pistol or handheld parachute red flare, and aerial pyrotechnic red flare can be used day or night. An electric distress light can only be used at night. The required number of VDSs aboard is three, except for the orange flag and electric distress light for which only one is required.

 *Each VDS must be in serviceable condition and the date of small-boat operations must be no more than 42 mos from the date of manufacture.*

After 42 mos the VDSs are considered expired, do not meet requirements, and must be replaced.

- **Exercise 12.3.3** *What is a sensible use for an expired VDS?*

### 12.3.4 Sound Signaling Devices

Sound signals are required to be made under certain circumstances. Meeting, crossing, and overtaking maneuvers, as well as periods of reduced visibility, all require sound signals to be used (Sect. 12.8.2).

 *All vessels under 39.4 ft (12 m) in length are required to carry an efficient sound signaling device (e.g., whistle, horn or other means), and to use that device to signal their intentions, as well as their position in periods of reduced visibility.*

- **Exercise 12.3.4** *For small-boat operations, what commonly available sound signaling device can be used?*

### 12.3.5 Navigation Lights

Vessels 16 ft (4.9 m) or more in length are required to display navigation lights between sunset and sunrise, as well as during other periods of reduced visibility, e.g., fog, rain, and haze. The details for the lighting requirements (e.g., the arcs of visibility and their location on the vessel) are not presented, because the defined small-boat operations are for good visibility and only during daylight hours. Furthermore, vessels under 23 ft (7 m) are not required to display anchor lights or day shapes unless anchored in or near a narrow channel, fairway, or anchorage, or where other vessels normally navigate. This restriction is rather easily avoided for the type of sampling envisioned for the small-boat operations described in this document.

- **Exercise 12.3.5** *What are the operating requirements for a small boat having installed lights that are not required?*

### 12.3.6 Recommended Items

There are a number of useful or recommended items that boat operators should carry regardless of explicit requirements for equipping a vessel.



**12.3.6.1 Marine VHF Radio** Most recreational vessels under 65 ft (19.8 m) in length do not have to carry a marine VHF radio. Cellular phone coverage is available in many coastal areas, but the use of a cellular phone should not be considered a substitute for VHF marine band radios for emergency purposes.

 *Cellular phones do not allow for direct communications with the rescue craft, so it is always recommended to have a marine VHF radio on board.*

Operators of vessels that carry a marine radio must follow the applicable FCC rules. The FCC does not require an operator of a recreational vessel with VHF radio (with or without digital selective calling capability) to have a license to operate the equipment. Operators must, however, follow the procedures and courtesies that are required of licensed operators specified in FCC rules (Sect. 7.1).





**12.3.6.2 Dewatering Device** The equipment recommendation for removing or *bailing* water from a boat is based on common sense. This may be the only means to take care of an emergency situation.

  All boats should carry at least one effective manual dewatering device, i.e., a hand-operated plunger, a bucket, or a large plastic bottle with the bottom cut off to serve as a water scoop.

This recommendation is in addition to any installed equipment the boat may have on board.



**12.3.6.3 Anchor** An anchor is useful, because an anchored vessel is a stable platform. More importantly, it can be used to keep the boat from running aground or into danger. A 3–6 ft (1–2 m) length of galvanized chain should be attached to the anchor. The chain resists abrasion better than a fiber line, and helps to hold the anchor flat on the bottom so it can dig in better. A suitable length of nylon anchor line should be attached to the end of the chain. Nylon line resists the strain from wind or wave action better.

**12.3.6.4 Fire Extinguisher** Boats less than 26 ft (7.9 m) long with outboard motors, portable fuel cans, and not carrying passengers for hire, need not carry portable fire extinguishers if the construction of the boat will not permit the entrapment of explosive or flammable gases or vapors.



  For small-boat operations, however, it is nonetheless advisable to carry one B-I fire extinguisher using CO<sub>2</sub> (4 lb), dry chemical (2 lb), halon (2.5 lb), or AFFF (1.75 gal) as the extinguishing agent.

The fire extinguisher should be checked to ensure it is not damaged and the pressure gauge or indicator is in the operable range (note CO<sub>2</sub> extinguishers do not have gauges). Mount or stow the fire extinguisher such that it is readily accessible.



**12.3.6.5 First Aid** To assist in retrieving a person in the water, extra PFDs are recommended as well as a life ring (or horseshoe) with a polypropylene line tied to it. A line attached to the PFD or ring thrown to the person in the water will provide a means for pulling them back to the vessel. A gaff hook should not be used to retrieve a person in the water. The boat operator should always make sure the propeller is stopped when assisting a person back on board near the stern.

   For small-boat operations, a first aid kit in a waterproof container is recommended.

**12.3.6.6 Batteries** Although, a laptop computer has a battery, as does the deck box for the optical equipment discussed here, it is recommended the vessel be equipped with a second battery to ensure scientific operations do not place an undue strain on the boat's original battery (Sect. 12.4), which is primarily used to start the engine.

   Batteries must be secured and terminals covered to prevent accidental arcing, which is a significant burn hazard to personnel and can start a fire.



**12.3.6.7 Fuel Tank** A portable fuel tank (7 gal capacity or less) must be constructed of unbreakable material and be free of corrosion and leaks. All vents must be capable of being closed.

   The fuel tank must be properly secured and have a vapor-tight, leak-proof cap.

**12.3.6.8 Engine** On vessels less than 20 ft (6.1 m) long and others with capacity plates, the small-boat operator should verify that the engine horsepower is equal to or less than that stated on the capacity plate. If installed, a kill-switch mechanism must be in proper working order.



► **Exercise 12.3.6** What is a kill-switch mechanism?

**12.3.6.9 Capacity** If there is no capacity plate on a single hull boat under 20 ft (6.1 m) in length, the carrying capacity should be computed.

  The maximum number of persons safely carried in calm weather can be determined by multiplying the length of the vessel by the width (both in feet), dividing by 15, and ignoring any fraction.

**12.3.6.10 Waste** There are several regulations governing the disposal of waste and garbage from a vessel (Sect. 12.5), so it is advisable to make sure a sealable container is brought aboard for all types of trash.

**12.3.6.11 Cold Waters** Sudden immersion of a person in cold water can induce rapid, uncontrolled breathing, cardiac arrest, and other physical body conditions that can result in drowning. An immersion suit delays the onset of hypothermia—the abnormal lowering of internal body temperature. Immersion suits should be stored and maintained according to the manufacturer's instructions, while being readily accessible on board the vessel. Prior to leaving the dock, all participants should be familiarized with the proper donning of an immersion suit.

   For small-boat operations in cold waters, i.e., ambient water temperatures of 59° F (15° C) or less, an immersion suit should be carried for every person on board.

If a person is forced to enter the water without an immersion suite, they should do the following (where possible): a) button up all clothing; b) cover the head; c) enter the water slowly, to give the body time to adjust; d) keep the head out of the water; and e) raise both knees with legs tucked and cross the arms across the chest to minimize the exposed surface area of the body.

If the boat capsizes it will likely float on or just below the surface. The effects of hypothermia can be reduced by getting as much of the body as possible out of the water. Most small boats built since 1978 are designed to stay afloat even if filled with water.

⚠️⚠️⚠️ *It may be possible to revive a drowning victim who has been under water a considerable amount of time and shows no signs of life by administering cardiopulmonary resuscitation (CPR) as quickly as possible.* Conventional CPR—that is, CPR with a combination of breaths and compressions—is recommended for all infants and children, for adult victims found unconscious and not breathing normally, and for any victims of drowning or collapse due to breathing problems (<http://www.heart.org> or <http://www.redcross.org>).

**12.3.6.12 Offshore Operations** For offshore operations, carry additional equipment beyond the minimum federal requirements, ensure all persons wear a PFD, and adhere to *all* the recommendations given above.

⚠️⚠️ *Offshore operations should also include an Emergency Position Indicating Radio Beacon (EPIRB), which provides a means to accurately determine the location of a vessel in distress.*

An EPIRB is registered when purchased with the vessel name, owner, and point-of-contact information. Once activated, it provides a signal to aid rescue operations (some EPIRB units provide a GPS position, but that is not the primary means of position determination).

## 12.4 Lead Acid Batteries

Flooded-electrolyte lead acid batteries have been available for a long time (before 1860) and are inexpensive and reliable for many applications. They have major deficiencies compared to AGM or gel batteries, however. For example, the escape of hydrogen and oxygen during charging (visually perceptible as bubbles in the individual cells) is a serious safety hazard if the gases are not properly vented.

⚠️⚠️⚠️ *A lead acid battery can produce an explosive mixture of hydrogen and oxygen, and contains a sulphuric acid electrolyte that can cause severe burns to body tissue.*

Furthermore, electrolyte stratification, wherein the concentration of acid becomes higher at the bottom of the cell and lower at the top, occurs as the battery is cycled during normal use. The stratification leads to reduced capacity and shortened battery life.

Gel batteries have been available since 1970. They use a combination of silica gel and dilute sulfuric acid in a viscous suspension as an electrolyte. Although a gel battery cannot be spilled when new, the electrolyte is difficult to keep homogeneous and the mixture can separate, thereby creating a flooded battery. Handling, vibration, and high temperatures contribute to separation, and the process occurs gradually even for normal temperatures and use. Gel batteries also require tight controls on the charging voltage and the inrush current or battery life suffers.

⚠️⚠️⚠️ *If the external terminals are short circuited, a lead acid battery is capable of delivering a high current that can cause severe burns and pose a potential fire hazard.*

AGM batteries, e.g., those manufactured by Concorde Battery Corp. (West Covina, California) use a glass fiber mat to hold the liquid electrolyte in direct contact with the plates (Fig. 38). The electrolyte remains immobilized even during use in high-vibration environments. AGM batteries require less space between plates, which provides a lower internal resistance, greater charging efficiency, and improved performance on discharge, especially at low temperatures.

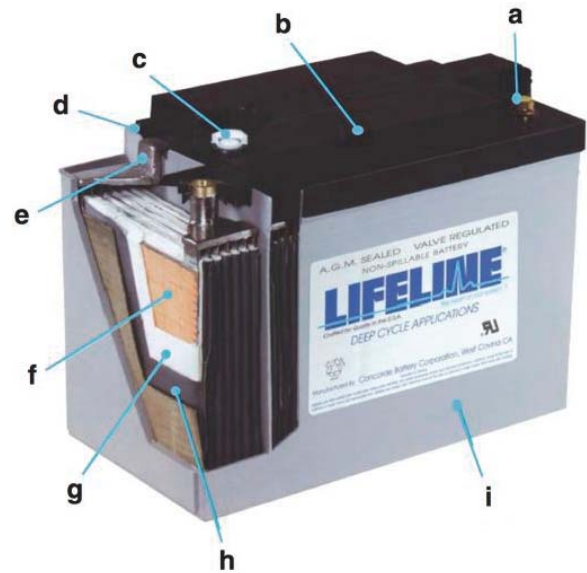

**Fig. 38.** A cutaway view of a Concorde AGM battery, in this example, one of the Lifeline models (<http://www.lifelinebatteries.com>) emphasizing the following design features: **a**) copper alloy terminals; **b**) lifting handle; **c**) sealed, pressure relief safety valve; **d**) cover-to-container seal; **e**) intercell connections; **f**) thick plates and high density oxide paste materials; **g**) AGM separator; **h**) polyethylene envelope; and **i**) reinforced copolymer polypropylene container and cover.

AGM batteries offer superior performance for small-boat operations for the following additional reasons: **a**) cannot be spilled in all orientations; **b**) never needs water added; **c**) the discharge rate is 3–5 times less than a flooded battery; **d**) negligible hydrogen gas emissions *unless severely overcharged*; **e**) no damage when frozen; and **f**) no electrolyte stratification, which prolongs battery life.

⚠️⚠️⚠️ *If a lead acid battery is at high ambient temperature (e.g., due to environmental factors or the charging voltage is set too high), battery temperature can increase rapidly, thereby producing extreme overheating of the battery, and the battery can melt, catch on fire, or even explode.*

To overcome the inherent risk of a lead acid battery, the following precautions should be followed when one (or more) is used for small-boat operations:

- Remove all metallic items (e.g., rings and watches), wear insulating gloves, eye and face protection, and use insulated tools when installing or servicing;
- Avoid contact with the electrolyte and in the event of an accident, flush with water and seek medical treatment immediately;
- Install in an adequately vented enclosure to prevent sun loading and accidental placement of metal objects across the terminals;
- Do not install near heat sources and provide adequate air circulation around the battery to prevent heat build up;
- Charge a battery in accordance with the instructions provided by the manufacturer;
- Keep all sparks, flames, and cigarettes away from batteries;
- Connect the cables tightly to the terminals to avoid sparks; and
- Never remove or damage built-in vent valves.

► **Exercise 12.4** *If a separate 12 VDC AGM battery is brought for the optical sampling, should it be kept separate or wired to the starting battery for the engine?*

## 12.5 Pollution and Trash

There are several applicable laws that govern pollution and trash while boating in U.S. navigable waters, as follows:

- The Refuse Act of 1899 prohibits throwing, discharging, or depositing any refuse matter of any kind (including trash, garbage, oil, and other liquid pollutants) into U.S. waters.
- The Water Pollution Control Act prohibits the discharge of oil or hazardous substances which may be harmful into U.S. navigable waters and requires all vessels with propulsion machinery to have a capacity to retain oil mixtures on board. A fixed or portable means to discharge oily waste to a reception facility is required. A bucket or bailer is suitable as a portable means of discharging oily waste on recreational vessels.
- The Act to Prevent Pollution from Ships places limitations on the discharge of garbage from vessels. It is illegal to dump plastic trash anywhere in the ocean or U.S. navigable waters. It is also illegal to discharge garbage in U.S. navigable waters, including the Great Lakes.

Given these regulations and the fact that small boats necessarily operate in windy conditions (usually) without an enclosed cabin to keep trash from being blown overboard, it is prudent to make sure a sealable container is available for all types of trash.

► **Exercise 12.5** *How can the requirement for proper trash disposal aboard a vessel be used to advantage?*

## 12.6 Instrument Mounts

For C-OPS deployments, the only instrument requiring a physical mount is the solar reference. Some small boats have a small console or radar mount that can be used to affix a pipe mast for the solar reference. In other cases, there may be opportunities to mount the mast to the transom, but some work prior to the field campaign might need to be scheduled. If none of these opportunities are available the so-called *bar stool* method is recommended. This method is particularly advantageous for soft-bottomed boats, e.g., inflatables.

The bar stool is fashioned from  $\frac{3}{4}$  in (1.9 cm) solid wood cut into a 1.5 ft (0.5 m) diameter circle, wherein a 1 in (2.5 cm) 316 SS pipe flange is attached to the middle of one side. The opposite side is covered with  $\frac{1}{2}$  in (1.3 cm) rigid foam (it is convenient to use a spray-on adhesive to attach the foam). The wood and foam are then covered with a thick vinyl material that is cut larger than the wood, e.g., about 30 in (76 cm) square. The vinyl is stretched over the wood and rigid foam and then stapled to the underside of the wood on the same side as the pipe flange. Once the staples are installed, excess vinyl is removed.

A 4 ft (1.2 m) long 1 in 316 SS pipe is then attached to the pipe flange, and a 1 in 316 SS coupler with a 1 ft (0.3 m) 316 SS pipe nipple is attached to the 4 ft (1.2 m) long pipe. The foam and vinyl padded side of the bar stool is placed facing the deck in the middle of the small boat. Four guy lines are attached to the pipe above the coupler (thereby preventing slippage). The four guy lines are then affixed to the sides of the vessel and tightened while checking that the vertical pipe remains approximately plumb. The reference mount is screwed onto the 1 ft (0.3 m) pipe nipple. The installation of a bar-stool mount is presented in Fig. 39.



**Fig. 39.** The installation of a bar-stool mount for the C-OPS solar reference with BioSHADE and BioGPS on a small inflatable launched from the R/V *SRV-X* into the Blackwater National Wildlife Refuge.

As soon as everyone is in the boat and seated at their sampling positions, the solar reference should be checked



for plumb and adjusted as necessary. As long as the persons conducting the sampling do not substantially change their positions, the solar reference data will be unbiased.

- **Exercise 12.6** *What is a disadvantage of the bar-stool surface reference mounting system?*



## 12.7 Launching and Loading

Small boats are typically launched at a boat ramp (or slipway) made of concrete. To facilitate launching, the vessel should be launched unloaded to the extent practicable. Most boat ramps have an adjoining parking facility with pull-through parking so the towing vehicle and the boat trailer can be parked conveniently nearby.

- **Exercise 12.7** *Why is it important to launch a boat as unloaded as practical?*

There are restrictions on launching and retrieving a small boat at most boat ramps. The simplest restriction is set by access permissions. In most cases, boat ramps are public and the public may use the facility by paying a fee. Usually the fee is paid by filling out vehicle and user information on an envelope, placing the fee in the envelope, and then depositing the envelope in a tamper-proof container. Another common restriction on boat ramp use is the time of day, i.e., the ramp and parking area might have hours of operation. Some boat ramps are in parks that are frequently locked after sunset.



The height of the tide can restrict the usability of the ramp unless the ramp continues well below the low-water level. Many lakes, which frequently have boat ramps, are artificial and may function as reservoirs. It is common for the water level to be controlled for agricultural, industrial, or municipal purposes, which means the water level may change significantly over a relatively short part of a season.

  *Proper planning of small-boat operations includes research as to the anticipated water level at the boat ramp during launch and retrieval.*



A recurring limitation on small-boat launching is the use of mitigation strategies to prevent the introduction of invasive species (e.g., the zebra mussel) into an uncontaminated ecosystem. This is particularly true in lakes used as freshwater reservoirs, wherein the invasive species may clog water distribution equipment. It is not unusual that the only boats permitted in such reservoirs are the ones already approved to be in the lake. For particularly important reservoirs, boat launching might be forbidden as a last resort to control the introduction of invasive species. It is also possible that gasoline engines will be prohibited in some reservoirs and only electric so-called *trolling* motors can be used for propulsion.

In some areas, small boats must undergo a rigorous inspection to ensure there is no evidence of water present

anywhere in or on the vessel that might transport an invasive species. Such *dry* requirements forbid the launching of a boat that is wet from rain or a wash down, because the water source cannot be determined. It is also possible that the launching of vessels registered in areas where the invasive species is already established will not be allowed.

  *Proper planning of small-boat operations in lakes and reservoirs must include research as to the existing regulations to control the introduction of invasive species.*

Prior to launching the boat, make sure the drain plug is in place and verify the fuel tank is full or sufficiently full to reach the sampling location, conduct the sampling, and return with a sensible fuel reserve.

  *Boaters should adhere to the one-third rule for fuel by using one third going out for sampling, one third for getting back, and one third held in reserve.*

Prepare the vessel for launching away from the ramp to the greatest extent practicable. Use at least two experienced people to launch the vessel. One is needed to drive the towing vehicle and the other to control the vessel. In many cases, three people are needed, so two hand lines on the boat can be properly controlled.

Do not block a ramp with an unattended vessel or vehicle. If the boat ramp is crowded, move the vessel away from the launch lane as soon after removing it from the trailer as possible. Return briefly to pick up the vehicle driver once the driver has parked the vehicle and is back at the ramp.

To launch the boat, the restraints keeping the boat on the trailer are loosened or removed. The towing vehicle is then used to back the trailer and boat down the ramp and into the water until the boat floats free, after which the boat is pulled to shore or a neighboring dock using a line attached to the vessel. Once the boat is secured, it is ready for loading, and the vehicle can be driven from the boat ramp and parked (usually in a designated area with pull-through parking to accommodate vehicle-trailer combinations).

Loading a small boat is based on distributing the load across the length of the vessel, while recognizing that the engine, battery, and fuel are heavy components mounted in the stern, plus the boat operator is seated in the stern. Another consideration is to ensure access to safety equipment and needed equipment, e.g., the anchor. To power the data acquisition computer, it is common to use a DC-to-AC inverter that is connected to a 12VDC battery.

From a layout perspective, the data acquisition operator should be positioned forward and the instrument operator amidships. This also places the cable bucket amidships, which helps balance the stern loads. This means the proximity of the needed items for the data acquisition operator should be placed forward. A useful and safe arrangement is to put the computer in a large waterproof case.

The inverter, computer AC adapter, deck box, and other equipment brought on board can be kept in a large plastic tub. The closed deck box can be rested on top of a plastic cover to protect the contents of the tub from any splashes. Care must be taken to ensure all cabling and connections are secure and not stressed by working in a confined space. Optical data are rarely collected in isolation, so the cooler for holding the water samples should be placed forward to help balance the load.

## 12.8 Boat Handling

An important aspect of boat handling is mastering the so-called *Rules of the Road*, which are published by the U.S. Government Printing Office, and involve international and inland rules<sup>†</sup>. Although they are mandatory to be kept on vessels over 12 m (39.4 ft) in length, every boat operator should have a copy. Because the emphasis here is on small-boat operations, only the inland rules are considered—and only in a brief format to establish the perspective for additional study.

These rules deal with the responsibilities of the boat operator when encountering marine facilities, shore structures, navigation aids, and other vessels. The latter involves a set of rules to establish which boat has the right of way and, thus, which boat must *give to*, i.e., yield the right of way to avoid a collision.

Common marine facilities encountered during small-boat operations are boat ramps, docks, yacht clubs, and marinas. Although small boats like the one in Fig. 1b can be launched with a minimal ramp, perhaps completely earthen, it is safer to use proper facilities wherein a concrete apron and floating dock are available. In terms of understanding the local marine environment, launching a boat at a yacht club or marina usually affords access to local knowledge about water depth and attendant hazards.

A common shore structure encountered during small-boat operations is a bridge. Bridges, dock areas, marinas, and yacht clubs are points of congestion with limited room to maneuver wherein the likelihood of encountering another vessel is increased, so caution is paramount.

► **Exercise 12.8** *What is a common restriction on boat handling within a marine facility, channel, or bridge?*

### 12.8.1 Navigation Aids

Two different colored buoys and markers mounted on pilings driven into the seabed are used to identify a channel of safe passage. The two colors are red and green. If

<sup>†</sup> The Coast Guard publication entitled “Navigation Rules, International—Inland” provides the present version of the rules and is available in principal ports or directly from the U.S. Government Printing Office (GPO) as follows: a) online at [www.bookstore.gpo.gov](http://www.bookstore.gpo.gov); b) by telephone order at +1-202-512-1800; or c) by mail from Superintendent of Documents, U.S. GPO, Washington, DC 20402.

a vessel stays midway between the two different colored navigation aids, it will not run aground. There is no assurance of not running aground if a vessel is too close to either of the channel markers—safe passage is assured in the middle of the channel, not on the edges.

To prevent confusion as to what constitutes the channel, a vessel returning to a port or dock must keep the red aids on the starboard (right) side. If a vessel is leaving a port or dock, the red navigation aids will be on the port (left) side. The red navigation aids have even numbers, and green ones have odd numbers.

The center of a channel with separated one-way traffic lanes is marked with red and white or black and white navigation aids. A vessel operating in separated one-way traffic lanes should stay in the middle of the lanes on the correct side and not maneuver in such a way as to oppose the direction of traffic. Separated traffic lanes are usually associated with very large ships and small boats should exercise extra caution when operating in such situations.

► **Exercise 12.8.1** *What is the memory mnemonic regarding navigation markers and a vessel returning to the dock?*

### 12.8.2 Right of Way and Signaling

The right of way is assigned to the vessel with the highest priority, represented here numerically, so 6 has the highest priority, as follows:

1. Power driven;
2. Sailing;
3. Commercial fishing;
4. Restricted to channel water depth;
5. Limited in turning ability; and
6. Unable to steer.

► **Exercise 12.8.2** *Given the description of a small boat for this document, what priority will typically be assigned to a small boat for right-of-way purposes?*

The three most common meeting engagements between two vessels, with the applicable rules of the road, are as follows:

- When vessels meet head-on, both keep astarboard.
- When crossing the path of a vessel, the right of way is given to the boat ahead and astarboard.
- When overtaking a vessel, the passing boat gives the right of way to the boat being passed.

A horn is used to signal the intended maneuvers of a vessel, wherein a “•” indicates a short blast on the horn and a “—” indicates a prolonged blast, as follows:

- a) Turning astarboard (•);
- b) Turning aport (••);
- c) Going astern (•••);

- d) Leaving the dock (—);
- e) Open bridge (—•); and
- f) Danger (•••••).

For the types of waters and, thus, vessels encountered during small-boat operations, horn signaling is usually not necessary.

### 12.8.3 Weather, Assistance, and Accidents

If the weather rapidly changes for the worse, the following precautions should be taken (where possible and applicable):

1. Recover any equipment that is in the water as quickly and safely as possible.
2. With a reduced speed, but with enough power to maintain headway, turn the bow of the boat into the waves at about a 45° angle.
3. Set a course for the nearest harbor that is safe to approach.
4. All persons should put on any extra clothing, don immersion suits, put on PFDs, and cover their heads.
5. Seat everyone except the boat operator on the bottom of the boat near the centerline.
6. Turn on navigation running lights.
7. Keep all accessible areas free of water.

► **Exercise 12.8.3** *If the shortest course to the nearest harbor results in a rough ride and water splashing into the boat, what should the boat operator do?*

 *If the engine subsequently fails, a sea anchor should be trailed on a line from the bow to keep the boat headed into the waves (a metal bucket will function as a sea anchor in an emergency).*

The operator or person in charge of a vessel is required by law to provide assistance that can be safely administered to any individual in danger at sea. In the U.S., the Good Samaritan Act protects boaters rendering responsible assistance.

 *Failure to render assistance to a boat in distress could result in fine or imprisonment.*

The operator or person in charge of a vessel is required to file a Boating Accident Report (BAR) if the boat is involved in an accident that results in the following: a) loss of life; b) personal injury which requires medical treatment beyond first aid; c) damage to the boat and other property exceeding \$500 (amount may vary in some states); or d) complete loss of the boat.

 *Boat operators are required to file a BAR with the nearest state and local authorities in the state where the accident occurred.*

The type of information collected includes, but is not limited to, the following: a) date, time and exact location of the accident; b) name of each person involved and their status (i.e., witness, dead, or disappeared); c) registration number and name of the vessel; and d) name and address of the owner and operator. If a person dies, disappears from the boat, or there are injuries requiring medical treatment beyond first aid, the BAR must be filed within 48 hr of the accident. If the accident involves more than \$500 damage or complete loss of a vessel, the BAR must be submitted within 10 days.

 *The owner of the vessel can be held responsible for the safety and condition of their boat even if someone else is at the helm; this is also true if the owner is not on board and someone else has permission to use the boat.*

## 12.9 Sampling

As noted above (Sect. 12.7), boaters should adhere to the one-third rule by using one third of the fuel going out for sampling, one third of the fuel for getting back, and one third of the fuel held in reserve. This practice encourages boaters to have full fuel tanks before conducting any sampling. The other caution is to not have more than one person standing at the same time, because a small boat can be a lively platform and sudden unanticipated motions can lead to a loss of balance and perhaps a person falling overboard.

► **Exercise 12.9** *What is the best orientation of the person operating the C-OPS backplane during small-boat operations, in terms of the stability of the vessel?*

Data acquisition on a small boat is simpler than on a large vessel. Although much of what was presented in Sect. 7.5.3 is applicable, the close proximity of all the persons and functions makes for much simpler communications and radios are not needed for data acquisition—although still useful for safety on the water (Sect. 12.3.6.1). As in the large vessel case, the computer operator starts and stops data acquisition and is responsible for the written log.

### 12.9.1 Personnel

Three people are preferred for conducting sampling on a small boat: one to handle the boat, one to deploy and recover the instrumentation, and one to operate the data acquisition software. Because small boats necessarily have limited space, however, only two persons might be practical if the vessel is quite small.

► **Exercise 12.9.1** *If only two people are available for small-boat operations, what are the safest assignments for the three tasks involved (boat handling, instrument operation, and software control)?*



### 12.9.2 Data Acquisition and Logging

Regardless of the number of persons aboard, attention must be paid to the proximity of the needed items to conduct sampling, as provided in Sect. 12.7. When sampling is commenced, the waterproof case holding the computer can be placed on top of the cooler holding the water samples. The case can then be opened and the computer plugged into the AC adapter that will be powered with 120 VAC power from the inverter.

Placing the computer on top of the cooler provides a useful height and stable configuration for the computer operator. The deck box can be placed on top of a plastic cover in the tub holding the additional electronics and other equipment brought on board. When sampling out on the water, the deck box lid can be lowered to provide splash protection for the deck box panel.

 *The inverter should only be turned on when all the equipment is ready to be used and the stability of the boat is assured.*

A recurring element in small-boat operations is the need to shield the computer screen from sunshine, so it can be properly viewed. An effective mechanism for this is to use the sheet that protects the profiler from overheating in sunshine as a shade (Fig. 40). If winds are a problem, the sheet can be held to the waterproof container holding the computer with large clips.



**Fig. 40.** Using the sheet that protects the profiler from overheating in sunshine as a shade, so the data acquisition computer screen can be seen in bright sunlight on board the R/V *Recon 18*.

For the first cast of the operations, or if the sampling environment has changed significantly (e.g., going from salt water to freshwater), an abbreviated cast should be conducted at first to verify the descent rate of the profiler and its vertical stability (i.e., trim). If the BioSHADE is part of the system, it should be used to collect one cast after three sequential in-water casts. Similarly, a water sample should be collected after the third cast.

If a current will take the profiler away from the vessel and if the water depth is suitable, it is advisable to anchor the boat while sampling. The general sampling sequence for small-boat operations follows from Sects. 7.5.1–7.5.3, so only cursory details are provided here: dark data are acquired and all caps removed, the profiler is lowered into the water and positioned away from the vessel, and then the desired number of casts are executed.

► **Exercise 12.9.2** *In areas of high heterogeneity or if the desired three casts cannot be obtained quickly, how should the sampling strategy be modified?*

### 12.10 Docking, Unloading, and Retrieval

Do not pull the vessel into a launch lane until the towing vehicle is at the ramp. The line is formed by vehicles with trailers, not by vessels in the water. Drop off the vehicle driver, and wait offshore and clear of the ramp until the driver arrives with the trailer.

Docking a small boat involves approaching the dock slowly, which is a natural consequence of the requirement to not leave a wake in a marine facility. One of the persons in the boat should have the bow line in hand, and once the boat is close to the dock, the line should be looped around one of the dock cleats. The forward momentum of the boat can be decreased by having the operator reverse the engine for a short time. Once the person with the bow line has secured it, that person can get on the dock with the stern line and secure it to a dock cleat. The preferred orientation is to use a cleat ahead of the vessel and another behind (Fig. 2b). In some cases, the lines will need to be repositioned to provide the desired orientation and stability against the dock.

After the boat has been docked, the equipment loaded for the sampling campaign should be removed, so the boat will float as high in the water as possible. The contents removed from the vessel should be placed where they cannot interfere with other persons using the dock or packed immediately into the towing vehicle. When packing the towing vehicle, it is important to position the contents so they cannot move or shift while driving, i.e., to fill all voids as is done when packing a box for transport (Sect. 10).

 *Do not leave anything in the boat that is not secured or tied down, because at highway speeds it might be blown out of the vessel and become a significant hazard to other motorists.*

Retrieving a boat from the water essentially involves the reverse of the steps to launch the boat. The towing vehicle is used to back the trailer into the water at an appropriate distance down the boat ramp. Hand lines are used to position the boat correctly over the partially submerged trailer.

 *Do not power the boat onto the trailer using the motor, because this can cause damage.*

In addition to damaging the boat and trailer if a mistake is made during *power loading*, the propeller wash can erode the sediment just beyond the ramp surface, thereby creating a large hole in the sediment and a mound where the eroded sediment is deposited behind the propeller. Trailer tires can get stuck in the hole, and boats can potentially run aground on the mound.

Attach the trailer winch line to the bow eye of the vessel and finish pulling the vessel onto the trailer by cranking the winch.



Stay clear of the direct line of the winch cable in case it snaps or control is lost of the winch.

Raise the engine or outdrive, pull the vessel out of the water, and inspect the positioning of the boat on the trailer. If the positioning is inappropriate, back down the ramp until the vessel floats free and correct the positioning.

While still at the ramp area, remove and dispose of all aquatic vegetation from the vessel and trailer. Remove any drain or scupper plug(s) to release any bilge or stored water. This will help prevent the spread of aquatic nuisance plants and organisms.

After the boat is correctly positioned on the trailer, drive the trailer away from the boat ramp to prepare for highway driving. Carefully stow and secure all equipment that is to be transported in the vehicle or boat. Secure the raised engine or outdrive with the appropriate mechanisms, which will usually include a stiffener to restrict the range of motion that the engine or outdrive can move.

Reapply the straps or mechanisms that hold the boat onto the trailer, taking care to secure all loose ends against windage. If removable trailer lights are used, reapply and secure them. Double check all cargo stowed inside the boat cannot be blown out of the boat. A large zipper bag that can be tied into the boat is a good container for properly stowing numerous smaller items. For open-hull designs, a netting that can be secured at the bow and from side to side is useful for providing an outer barrier to keep cargo inside the vessel at highway speeds.

Wash the boat and trailer down with freshwater making sure to force water into all crevices or areas where water can be stored. Attach a hose to the proper fitting on the engine, so it can be run and flushed with freshwater. Many boat launching facilities include an area and water source for this purpose (sometimes it is coin operated).



After the boat and trailer have been washed down, the functionality of all trailer lights should be confirmed to ensure the recent submersion in water has not created a fault.

► **Exercise 12.10** What should be the course of action if one of the trailer lights stops working after being submerged to launch or retrieve the boat?

Before towing the trailer, inspect the functionality of the trailer and hitch components following the list provided in Sect. 12.2.

## APPENDIX A ANSWERS TO EXERCISES

► **Exercise 1.1** What is likely the most significant advantage and disadvantage of deploying an autonomous radiometric system on a terrestrial structure as opposed to an offshore structure or research vessel (R/V)?

A terrestrial structure will very likely not need to generate its own power, but will very probably have to deal with light contamination sources, particularly if nighttime observations are made.

► **Exercise 1.2** What types of in-water platforms are not mentioned in the five platform classifications that might benefit from mobilization protocols?

Buoys, unmanned surface vessels (USVs), unmanned underwater vehicles (UUVs), and taught cable moorings are not mentioned. All of these deployment options can use the same instrumentation and cabling presented in this report, so those sections will have applicability to these alternative platforms.

For example, a proposed use of the C-OPS instrumentation is to mount the solar reference on a USV and tow the backplane at depth, using the same cable presently used, behind the USV (Fig. A1). In this scenario digital thrusters from the new Compact-Propulsion Option for Profiling Systems (C-PrOPS) accessory (Exercise 3.1 and FAQ 18) are used to drive the backplane to the surface and slightly towards the USV every 30 min (weather and illumination conditions permitting). A profile is then obtained from the free descent of the backplane back to the tow depth while the tow cable is relatively slack.

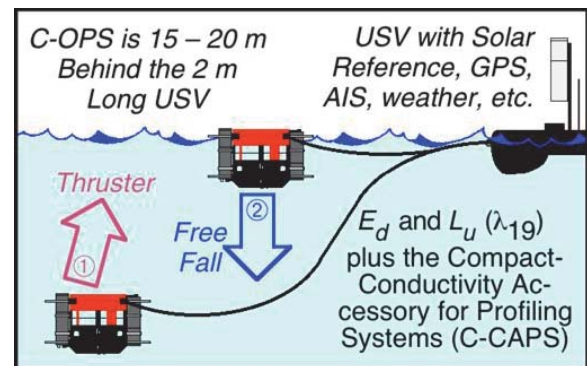

**Fig. A1.** A concept drawing for deploying a C-OPS system with a small USV.

In addition, the Compact-Conductivity Accessory for Profiling Systems (C-CAPS) would also be added to the backplane so the verification of homogeneity of the upper water column when influenced by freshwater input (e.g., ice melt and estuaries) can be better verified. The USV would also have weather instruments, a GPS, and an Automatic Identification System (AIS). The AIS is used for automated collision avoidance with other vessels similarly equipped (medium- and large-sized vessels that could damage the USV are required to have AIS).

- **Exercise 1.3** *What are additional advantages of a free-fall profiler like C-OPS with respect to the following deployment alternatives: a) winch and crane frame, b) buoy, and c) glider?*

The respective advantages of a free-fall profiler are as follows: a) it is not perpetually responding to the surge and heave of the sea surface, b) it is not in near proximity of a surface perturbation, and c) it has minimal self-shading.

- **Exercise 1.4** *What types of deployment might logically require a different type of cable for the surface reference than the one provided?*

The cable provided with a new system assumes relatively short-duration campaigns (i.e., up to 8 weeks) with a standard power configuration, in terms of voltage and current. For longer-duration deployments, cable with a thicker outer jacket might be needed for enhanced protection against a greater likelihood of accidental damage from increased exposure to platform maintenance operations or enhanced wind loading, which can lead to chaffing.

Similarly, if a cable must be laid on a deck and subjected to foot traffic, a stronger outer jacket and a sacrificial overwrap to minimize the trip hazard and protect the cable is recommended. In addition, if the cable run is significantly longer than usual, cable with a larger wire gauge might be needed to overcome resistive losses, while staying within a preferred voltage range.

- **Exercise 2.0** *What is a principal concern for an electrical cable that is designed to be used to deploy and recover an instrument system?*

Whenever an electrical cable is used to support a mechanical load (i.e., it is pulled), a primary concern is ensuring the induced strain is restricted to the cable and not transmitted to the connectors and conductors, because neither the connector, the locking sleeve, nor the pin and socket connections are designed to withstand significant pulling forces. A common and reliable way of preventing tensile forces being applied to the connector and locking sleeve is to transfer the load from the cable to a strength member using a *chinese finger*. For an in-water instrument like C-OPS, the strength member is the harness attached to the backplane, which is connected to the chinese finger using a shackle.

- **Exercise 2.1** *What is the definition of an ungrounded electrical system, and what are the advantages and disadvantages of such a system?*

In an ungrounded electrical system, there is no intentional conducting connection between a service or equipment enclosure and the Earth. Although grounding has the advantage of high fault levels to trip over-current-protection devices (e.g., a fuse or circuit breaker), such faults present dangers posed by electrical arcing and flashing hazards.

In addition, some functions require higher service continuity to ensure a more significant safety hazard is not produced when the circuit that would normally trip open removes a vital capability, e.g., propulsion or steering. This is based on the argument that most ground fault currents are small and result in negligible burning or heating when the fault is not cleared; consequently, line-to-ground faults can be left on the system until it is appropriate to find and clear them under controlled circumstances.

A major disadvantage to an ungrounded system is the difficulty in locating a line-to-ground fault. In general, the fault must be located and repaired quickly, because if a second fault occurs, the subsequent fault is usually more extensive than the first (e.g., burning and loss of protective insulation is likely), thereby extending the extent and cost of the repair process. Finding the fault can be a time-consuming process and if it occurs during a period of heightened safety concerns (e.g., during a severe storm), the amount of time to clear the fault can be significant and the initial problem that created the fault can escalate to more dangerous levels.

- **Exercise 2.2** *What other common resistance factor besides water, especially seawater, is important to be aware of when working around electrical components?*

The resistance of the internal human body can be as low as  $500\ \Omega$ . Consequently, if there is a puncture of the skin at the current path, the shock danger increases dramatically.

- **Exercise 2.3** *How can the cable pins and sockets be used to establish the run direction, and why is that an advantage?*

Because an instrument will always have a bulkhead connector with male pins to receive power, the run direction to the instrument is set by simply taking the end of the cable with the female sockets towards the instrument. Similarly, the male pins are run towards the deck box. This provides the advantage of not having to actually have the instruments in question to properly plan a cable run.

- **Exercise 2.4** *What is a perceived “disadvantage” of all cables having the same pin assignment?*

If all cables have the same pin assignment, the electronics must be able to detect the “resistive” length of the cable to ensure proper line voltage is provided. This extra circuitry adds to the cost of the electronics and, thus, is sometimes perceived as a disadvantage.

- **Exercise 2.5** *What types of circumstances might require a locking sleeve to be replaced?*

A common reason for replacing a locking sleeve is that it is accidentally damaged, in which case, it should be replaced promptly. Another reason for replacing a locking sleeve is to change the purpose of the cable, because a particular type is needed, but only other types are available. For example, if an extension cable is needed, but only an interface cable is available.



- **Exercise 2.6** *What is the advantage of a cable with an MP/MR connector on one end and an FS/FG connector on the other end?*

It can be coiled up and plugged into itself to protect the connector pins and sockets, and the locking sleeves mate to prevent accidental disconnection.

- **Exercise 2.7** *For a cable with an MP/FG connector on one end and an FS/FG connector on the other end—which have locking sleeves that do not mate—what is a reliable way to protect the connectors while stowed, if dummy plugs with the appropriate locking sleeves are not available?*

Plug the male pins into the female sockets and then use vinyl electrical tape to join the two FG locking sleeves together to prevent disconnection.

- **Exercise 2.8** *What vulnerability is created when an extension cable is connected to a deck box?*

The male pins on the cable can be pushed into the female sockets on the deck box, but the locking sleeves will not mate, which means the cable can be accidentally disconnected from the deck box.

- **Exercise 2.9** *What is another disadvantage of an all-plastic locking sleeves?*

An all-plastic locking sleeve cannot be changed in the field. A common way this type of locking sleeve is changed is to cut a slit through the outer shell along the long dimension of the locking sleeve, so it can be spread open enough to pass over the diameter of the much smaller cable; the locking sleeve is then taped together to give it some holding strength, but it is obviously and seriously compromised in such a state.

- **Exercise 2.9.1** *What is another reason to not use excessive grease when lubricating connectors?*

Excess grease is easily transported from one surface to another through the routine handling of the cabling and equipment, and could ultimately be transferred to one of the optical apertures (e.g., irradiance diffuser or radiance window), which will alter the characterized responsivity of the aperture.

- **Exercise 2.9.2** *What is an “appropriate” way to stow dummy plugs?*

Like cables, dummy plugs should be stowed connected to their opposite type and joined together with mated locking sleeves.

- **Exercise 2.9.3** *What is an appropriate way to protect exposed pins or sockets for an extended period of time if no dummy plugs are available?*

The connector is inserted into a clean plastic bag, and the bag is over wrapped with vinyl electrical tape to secure the bag to the cable. If a bag is unavailable, tape can be used as follows: a) invert the tape, so the sticky side is up away from the connector; b) wrap the inverted tape around the connector to form a small pouch that completely covers the connector; and c) invert the tape, so the sticky side is now facing the connector pouch, and overwrap the pouch with the tape to secure it to the cable.

- **Exercise 2.10** *What happens to the integrity of the shield when shielded and unshielded cables are mixed together in a single cable run.*

Mixing shielded and unshielded cables in a cable run will nullify the protection of the shield. Typically the simplest way to preserve the benefit of shielded cable is to only use shielded cable, or to enclose the cabling in a separately grounded shield, which is usually not practical.

- **Exercise 3.0** *How does the fact that a microradiometer PCA contains circuits so small it must be machine made affect quality?*

Machine-made components provide a higher quality assurance (QA) than legacy handmade components, because the high degree of repeatability removes almost all of the individualized sources of variance in the manufacturing process, e.g., operator-to-operator skill differences, alertness stressors at the start or end of the day (or week), etc. Machines are not foolproof, however, but machine-made components tend to fail quality control (QC) procedures in batches whereas handmade components usually fail as individual items.

*Batch failures are easier and cheaper to detect than individualized failures, because a subset of a production can be analyzed for QA, rather than every single item. The experiences with microradiometers is that the overall quality is significantly improved with having as many machine-made components as possible.*

- **Exercise 3.1** *How else might the solar reference be used as a “reference”?*

Because microradiometers have 10 decades of dynamic range, they can be used for making measurements under moonlight, typically the Disseminating to Gibbous Moon (75% of lunar disk), although challenges do exist for some of the shorter wavelengths due to low signal levels. If C-OPS is deployed under moonlight, the solar reference becomes a lunar reference and provides the same functionality except now the source of temporal evolution is the Moon rather than the Sun.

As a proof of this concept, in-water measurements were made under a full Moon using a C-OPS with the C-PrOPS accessory (Fig. A2a) for Compact-Buoyant Environmental AOP Measurements of the Moon and Sun (C-BEAMMS) activity (Fig. A2b). The thrusters on C-PrOPS allow the profiler to be maneuvered away from the deployment platform, in this case a dock, under difficult conditions (night-time).

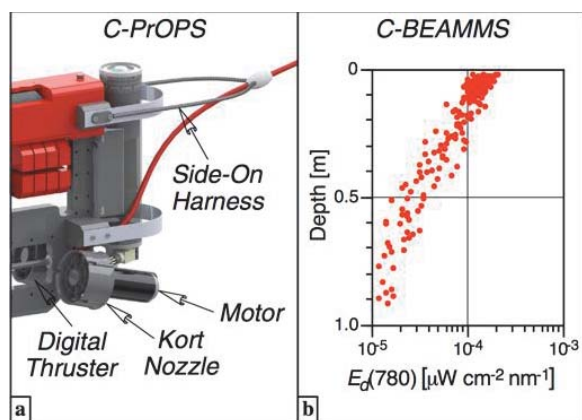

**Fig. A2.** Optical measurements made under challenging low-light levels from a dock used a) the C-PrOPS accessory concept for obtaining in-water profiles, for example, b)  $E_d(780)$  in the upper 1 m of the water column.

- **Exercise 3.2** Why does rotating the BioSCAN radiometers perpendicular to the sun plane not eliminate sun glint contamination in the  $L_T$  measurement?

Rotating the BioSCAN radiometers perpendicular to the sun plane does not eliminate sun glint contamination in the  $L_T$  measurement, because the sea surface is typically wind roughened. A rough sea surface contains a random occurrence of capillary waves wherein oblique wave facets can reflect light into the FOV of the  $L_T$  instrument. Because the capillary waves represent small, fast-changing wave slopes, the glint pattern is always changing and can be filtered out if the data acquisition is sufficiently fast, i.e., 6 Hz or more (Hooker et al. 1999).

- **Exercise 3.3** Why is knowing the vertical orientation of the profiler during descent important?

All sensors on the C-OPS backplane ( $E_d$  and  $L_u$  or  $E_u$ ) must make planar measurements to within  $5^\circ$ , because the light fields are not isotropic. C-OPS uses a two-axis set of tilt sensors (arbitrarily denoted pitch and roll) to determine the resulting departure from vertical. The same sensor set is also in the solar reference.

The vertical tilt data, however, are used differently for the above- and in-water sensors. Because the in-water sensors are falling through the water column, there is a separate source of changing illumination that is convolved with the tilting of the sensors. Given that the light fields are not isotropic and the water column is in general not homogeneous, the convolution of changing illumination from tilting and falling is difficult to correct. The simplest procedure is to filter out all data exceeding a  $5^\circ$  vertical tilt.

The above-water sensors does not experience a similar convolution, and in fact remains at the same vertical point in the light field (within the limits of the vertical scale of the atmosphere). Although cloud heterogeneity contributes to the anisotropy, the effect is usually small and the measured solar illumination can be derived from a fit to the data rather than having to filter it.

- **Exercise 3.4** Are there negative consequences if the C-OPS underwater cable is accidentally connected to the reference bulkhead rather than the underwater (profiler) bulkhead on the deck box?

There is no difference between the two deck box bulkhead ports—both support the reference or profiler. There is a potential for software problems, however, if port assignments are changed between software restarts. If ports are reassigned, the acquisition software should be restarted (remembering that connections and disconnections should only be done with all power off).

- **Exercise 3.5** If so much of a modern acquisition system is computerized and can easily accommodate automated record keeping, why retain a written log?

Despite the advantages of computer logging, maintaining a written log is frequently faster during data acquisition, because it does not interrupt the acquisition process. In addition, failures in electronic systems do occur, so a written log provides a minimum backup in the case of such failures. A written log should be transcribed to a digital file promptly after data acquisition is completed, so all details are fresh and easily remembered.

- **Exercise 4.0** Which is more vulnerable to failure, the cable or the connector?

Each are similarly vulnerable for different reasons. A cable is much longer than a connector, so it has an *integrated exposure to a fault* that makes it more vulnerable and if the cable is strung in a particularly hazardous location, the vulnerability increases significantly. For example, if 50 m of cable is strung out along a ship, each point in the cable can be accidentally damaged by normal activities.

A connector is a *single point of stress*, so it can fail catastrophically if stresses exceed thresholds. For example, if the cable is pulled on inappropriately, the connector usually takes the brunt of the load and the conductors can be pulled to the point wherein connection to the pins or sockets is broken. For this reason, it is advisable to apply strain relief where two cables connect.

- **Exercise 4.1** What is a common mitigation factor that must be considered when assigning priorities for mobilization work?

Weather can completely alter a well-planned mobilization activity. If there is a high probability of rain, snow, or icing during a particular part of the work plan, it is advisable to reschedule the work plan so that time period involves indoor work, especially if there is a chance for lightning or other conditions (e.g., high wind) that might restrict access to needed parts of the ship.

- **Exercise 4.2** What should happen next given the priority matrix?

The fact that the manufacturer provided the adapter cable suggests it should simply be installed, and the old sensors tested for proper functionality as soon as possible, so a timely mobilization can be completed. The remote location of the field campaign and the fact that the ship is about to sail, however, suggests caution is warranted.

► **Exercise 4.3** *What is a common and simple way to attach a reference sensor mount to a ship?*

The railing on a ship is designed to prevent a person from falling overboard and is a common attachment point for a sensor mount. It also affords a simple attachment mechanism, because the scaffolding industry provides a diversity of fixtures to join pipe securely. If pipe is the primary part of a mast, it can be quickly and reliably attached to the ship's railing with scaffolding clamps or stainless steel hose clamps (Fig. A3). Railing is usually made of pipe with two different diameters, so shimming material is frequently needed to plumb the mast (usually at the bottom).

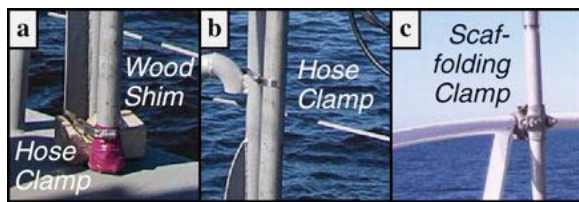

**Fig. A3.** Three examples of affixing a mast on a ship: **a)** the bottom of a pipe mast shimmed away from a stanchion, the threads of the pipe protected with rubber and purple vinyl tape, and the mast affixed with a hose clamp aboard the R/V *Gulf Challenger*; **b)** a mid-point part of the mast affixed with a hose clamp aboard the R/V *Gulf Challenger*; and **c)** a pipe mast affixed to the railing using a scaffolding clamp aboard the R/V *Tethys II*.

► **Exercise 4.4** *What is a likely reason for avoiding ship's equipment that appears to be used infrequently?*

It is common that infrequently used pieces of equipment nonetheless are serviced and tested at sea. If the cabling has to be removed for this work to be completed, valuable data might be lost.

► **Exercise 5.0** *Why is it important that the pipe used for sensor mounts not be corrosive and, thus, not a source of particles?*

The concern for preventing pipe from being a source of particles is mostly to stop the transportation of contamination from the pipe to the optical apertures of the sensors. If the pipe is *dirty*, it is rather easy to transfer dirt to the optical apertures when handling both in the field.

► **Exercise 5.1** *What is a theoretical disadvantage with multiple tool bags—rather than just one big tool box—that might actually provide a practical advantage?*

The use of multiple tool bags means some tools are duplicated, whereas in a single tool box there need only be one. The duplication is actually an advantage, however, because such tools are clearly needed for more than one task, so having more than one provides built-in spares.

► **Exercise 5.2** *What is the advantage of a smooth-band, worm-drive hose clamp, and how can it be improved?*

The smooth-band design prevents the drive screw from cutting into the material below the band, so the individual components are not marred. The band also has rolled edges to prevent them from cutting into the surface being clamped. Extra insulation can be provided by adding heat-shrink tubing around the band where it is in contact with the device being clamped.

► **Exercise 5.2.1** *What is the difference between 304 SS and 316 SS?*

304 SS contains 18% chromium and 8% nickel and is also known as 18/8 SS. 316 SS contains 16% chromium, 10% nickel, and 2% molybdenum. The molybdenum helps resist corrosion to chlorides, e.g., seawater (FAQ 5).

► **Exercise 5.2.2** *What are the suggested pipe wrench sizes as a function of pipe diameter?*

The suggested pipe wrench sizes as a function of pipe diameter (Table A1) show that the 10 and 12 in wrenches used in these protocols (Sect. 5.1) provide a large range of useful and commonly encountered pipe diameters.

**Table A1.** The recommended† pipe wrench sizes (left entry in columns) for ranges of pipe diameters (right entry in columns).

| Wrench and Range |            | Wrench and Range |              |
|------------------|------------|------------------|--------------|
| 6 in             | 1/8–1/2 in | 12 in            | 1/2–1 1/2 in |
| 8                | 1/4–3/4    | 14               | 1/2–1 1/2    |
| 10               | 1/4–1      | 18               | 1–2          |

► **Exercise 5.2.3** *What are some of the advantages of a modular mast made from commercial pipe and fittings?*

A modular mast built from commercial pipe and fittings provides a significant amount of flexibility for several deployment problems, as follows:

- It is more easily shipped, because the longest piece is 4 ft (1.2 m);
- If one component is damaged, it is easily and cost effectively replaced; and
- If additional sensors need to be added, it is easily reconfigured using easy-to-obtain fittings.

► **Exercise 5.2.4** *What is a likely disadvantage of a telescoping mast versus a pipe mast in winter conditions?*

A telescoping mast has moving parts that must slide past one another for the mast to be extended or retracted.





During winter conditions, water can freeze between the moving parts and prevent movement, which means the mast will be frozen in place.

With BioMAST, hot air can be blown into the base of the mast (e.g., with a heat gun), which rises up and melts the ice (Fig. 13).

► **Exercise 5.3** *What is another reason to not over tighten the fitting that mates the BioSCAN frame flange to the vertical 1<sup>1</sup>/<sub>4</sub> in 316 SS support pipe?*

It is essential that the connection between the flange on the bottom of the BioSCAN frame and the vertical pipe supporting the frame can be disassembled at the end of the field campaign for proper demobilization and packing. Although anti-seizing stainless steel joint compound will significantly help reduce the likelihood of galling (Sect. 5.2.1), not over tightening the connection is also beneficial.

► **Exercise 5.4** *What is the consequence of not correctly specifying the offsets of the light sensor apertures with respect to the pressure transducer?*

An incorrect depth offset for a light sensor aperture artificially brightens or darkens the data. If the offset places the aperture shallower (deeper) in the water column than it is supposed to be, the data will appear darker (brighter) than the offset would normally provide. Similarly, an incorrect pressure tare can artificially brighten or darken the data. A comprehensive analysis of the sensitivity of common optical data products to these avoidable uncertainties is provided by Hooker et al. (2013).

► **Exercise 5.5** *What is one of the potentially hazardous accidental misuses of industrial hook-and-loop fasteners that can lead to damaged equipment?*

If too large a surface is used, either as one piece or the sum of several pieces, the pulling force to remove the equipment can be so great the shell of the equipment can be damaged, i.e., distorted or even pulled apart.



Industrial hook-and-loop fasteners withstand a large pulling or shearing force and must be used sparingly.

► **Exercise 6.0** *When planning a cable run should the amount of cable that is strung inside the vessel be minimized or maximized?*

Opinions differ about which of these choices is optimal. On the one hand, cable strung within a ship is more protected from mishap and weather than cable strung outside the ship, but it is usually harder to install than the open areas outside and it is much less accessible once the ship sails, because so much happens inside the ship. The perspective adopted here is to be prepared for, and to be able to respond rapidly to, fault conditions. This means outside cabling is preferred and the rest of this document assumes such a perspective.

► **Exercise 6.1** *What are the advantages of using high-visibility (e.g., neon) cable ties?*

By selecting a unique easy-to-see color, it becomes much easier to remove an installed cable without accidentally releasing the wrong cable tie and compromising a prior cable installation. In addition, the high visibility makes it easier to find cable ties or ends that are cut loose and then dropped. The latter is important, because it is the responsibility of all mariners to not introduce plastics into U.S. navigable waters (Sect. 12.5).

► **Exercise 6.2** *When applying color-coded tape to a cable, where should it be applied?*

Color-coded tape should not be applied to the locking sleeve. It should be applied as a few number of over wraps a short distance away from the connector bodies (1–2 in or 2–5 cm) at each end of the cable (e.g., Fig. 15), so it is obviously visible when each locking sleeve is mated.

► **Exercise 6.2.1** *How does a coil of slack cable attached to a fixture (e.g., a pipe mast, as shown in Fig. 16a), provide strain relief?*

The strain relief is provided by the cable tie, because if the long end of the cable is brought under tension, the cable tie prevents the tension from being transmitted to the cable connector and instrument bulkhead combination.

► **Exercise 6.2.2** *What is the principle vulnerability of using a Y-cable to power two instruments?*

The principle vulnerability of a Y-cable is two instruments can be removed from service by a single cable failure. Furthermore, unless a spare Y-cable is available, it cannot be simply swapped out. In most cases, a replacement Y-cable will have to be fashioned from available pigtail and cable spares, which might mean sacrificing one or more cables to make the replacement (assuming no part of the original cable is available for useable parts).

► **Exercise 6.2.3** *How can the cable initiation in Fig. 16c be improved?*

The top left blue circle indicates a loose cable tie, which provides a range of motions for the red sea cable. The red sea cable should pass over—not under—the black Y-cable connecting the two sensors to the sea cable.

► **Exercise 6.3** *If the only two cables that will span a cable run are two interface cables, how can they be re-configured to connect properly?*

One of the interface cables will have to be converted to an extension cable, by changing the MP/FG connector to a MP/MR connector. The easiest way to do this is to use a MR locking sleeve from a dummy plug. The sequence of steps are as follows (Sect. 2.5):

1. Slide the FG locking sleeve away from the connector.

2. Remove the split ring from the MR locking sleeve using a miniature flat-bladed screwdriver.
3. Wedge open one edge of the split ring, and rotate it over the cable until the ring is captured around the cable.
4. Slide the MR locking sleeve over the MP connector body.
5. Push the split ring into the MR locking sleeve and seat it into the groove using the miniature screwdriver.

Because this is probably a temporary cabling arrangement, it is advisable to not remove the original FG locking sleeve, so the original configuration can be easily restored by removing the added MR locking sleeve when appropriate.

 Do not simply mate the two original male and female connectors and leave them without mated locking sleeves, even if tape is applied to the connectors, because a proper mating of the pins and sockets requires mated locking sleeves.

► **Exercise 6.3.1** *What is another advantage for having a sea cable that can be disconnected close to the cable bucket?*

Being able to disconnect the cable bucket from the cable that runs to the deck box allows the cable bucket and the profiler to be easily moved to a safe location inside the ship in the event of severe weather, i.e., behind a door that will be closed or dogged shut.

► **Exercise 6.3.2** *If the BioSCAN (two radiometers) is mounted on the bow of a ship along with a surface reference (1 radiometer) without BioGPS and BioSHADE accessories, how can all three devices be powered and the data acquired with one power-telemetry cable going back to the deck box?*

An extra Y-cable is needed to provide a cable route from the one cable coming from the deck box. In this case, one part of the Y-cable will go to the Y-cable on the BioSCAN frame, and the other part will go to the solar reference following the cautions in Sect. 6.2.1.

If using one cable from the deck box is required as a mission-saving requirement and the BioGPS data are also required, then the BioSCAN instrument cluster and the BioGPS and irradiance instrument may all be connected together with spare y-cables. The BioSHADE instrument must be disconnected from the system and the shadow band stowed out of the field of view of the irradiance instrument. Dummy plugs should be properly installed on the bulkheads of the BioSHADE.

► **Exercise 6.3.3** *What is a common feature of weather decks that can provide a convenient and secure location to run cable on top of a deck?*

Scuppers are usually installed along the bulwarks of the weather decks. They are frequently continuous troughs and at each brace that supports the bulwark, a *keyhole* is cut in the corner where the deck and bulwark meet. The keyhole allows cable to be run along the scuppers. Vents and other pipes that emerge from the deck below, or the grating covering the trough, allow the cable to be secured.

 *The water that drains into the scuppers can be rather dirty and contain oils and grease, so any cable that is laid in a scupper should be cleaned with a degreasing solvent and thoroughly scrubbed with mild soap at the end of the field campaign.*

► **Exercise 6.4** *What is a sensible precaution before connecting any cables to a deck box?*

Before any cables are connected to a deck box, make sure the power switch is off. Deck boxes have internal batteries, so it is insufficient to expect they are off if they are not plugged in. The switch on a deck box latches, which means it must be lifted up before moving it to a new state. The latching feature prevents accidental movements of the switch.

► **Exercise 7.0** *What is the difference between SPF and UPF?*

SPF is a standard for measuring the effectiveness of sunscreens applied to the skin to mitigate exposure to UVB (280–315 nm) radiation—there is no agreed upon standard for UVA (315–400 nm) protection in the U.S. The numerical rating indicates a longevity for exposure. For example, if a person's skin turns red after 10 min in sunlight, an SPF 10 sunscreen should enable the person to remain outside 10 times longer (i.e., approximately 100 min) before that person's skin turns red. UPF is a transmission test for measuring how much UVA and UVB radiation is blocked by a fabric. A UPF rating of 50+ is the highest rating and means the fabric blocks 97.5% of both UVA and UVB rays.

► **Exercise 7.1** *What would be a likely disadvantage of using cellular telephony rather than R/T, if it were available?*

An important feature of R/T is the ability for other operators to monitor the traffic on a particular channel. This is an important safety feature, because it means, for example, the bridge can intercede if an emergency situation develops during a deployment of an instrument from the deck of a ship. Although some cellular telephone providers do provide such a capability, it is not automatically available to all customers, particularly if a customer uses an alternative service provider. Another advantage of R/T is there is no subscription costs; once the handsets are purchased, an unlimited amount of communications are available at no extra cost.

- **Exercise 7.1.1** *What happens when two R/T operators transmit at the same time?*

If the length of the transmissions are almost exactly the same, neither operator will be aware the other transmitted and both will wait for a reply, if one is expected. If one transmission is rather longer than the other, the operator who sent the shorter transmission will hear the clipped ending of the longer transmission, and should realize the other operator transmitted a message. The cognizant operator should provide the lost original short message and at the same time request a retransmission of the other operator's longer message.

- **Exercise 7.1.2** *In addition to machinery noise, what is a common sources of noise on an outside deck that can degrade R/T clarity, and how can it be mitigated?*

A common source of noise on an outside deck besides engine noise is the wind. When wind blows over a handset microphone it creates a significant amount of noise. If it is not possible to move to a location that is sheltered from the wind, sometimes facing opposite of the wind direction, i.e., with the wind to the back, will mitigate this noise source.

- **Exercise 7.1.3** *What is a common mistake for new R/T practitioners that leads to incomplete messages?*

A common mistake for new R/T practitioners that leads to incomplete messages is not synchronizing the coordination between pressing the PTT button and speaking. The two common failure modes are either speaking first and then pushing the PTT button, or forgetting to push the PTT button at all. Another source of incomplete or missing messages is trying to use a handset while wearing gloves, which can sometimes not provide the kind of tactile feedback to the fingers that the PTT button was pressed.

- **Exercise 7.1.4** *What is the difficulty with the above example, "Lab, Deck; station in two minutes; Out." for new practitioners, and how can the messaging be improved?*

The example message assumes someone is listening, and if they are not, there is no way for the sender to know that because the sender was "Out" at the end of the message. For new practitioners who might not be capable of the kind of R/T discipline the example requires (e.g., perhaps they left their post to deal with an unexpected problem and did not take their radio with them), a more foolproof message is, "Lab, Deck; station in two minutes; Over." Now, if Lab does not respond, Deck knows there is a breakdown in R/T discipline and can send someone to investigate.

- **Exercise 7.1.5** *Why is blowing air from the lips over a handset microphone an inadequate radio check?*

Blowing air from the lips over a handset microphone confirms a level of operability, but it does not provide a good measure of signal strength and no measure of clarity. Both of these transmission qualities are important when evaluating radio checks.

- **Exercise 7.1.6** *Assuming the operators in the above R/T traffic are experienced, what would be a shortened, but equally effective exchange between the Deck and Lab?*

Deck: "Lab, Deck; surface, surface." «Deck knows Lab is aware the only instrument being deployed is the profiler and that Lab is waiting to be told it is on the surface and properly positioned under stable illumination conditions, so surface is repeated to establish that the required priorities have been met. If Deck had to get the profiler farther from the ship or if a cloud was approaching the Sun, the exchange would have been, "Lab, Deck; surface, wait one." and Lab would have responded, "Deck, Lab; Roger, standing by.»»

Lab: "Deck, Lab; good-to-go, good-to-go." «Lab knows Deck is aware that instabilities, like clouds nearing the Sun or near proximity of the profiler to the ship, will be reported or properly dealt with, so there is no need to ask for something that was not stated. Furthermore, Lab knows Deck is waiting to be told to proceed, so the "good-to-go" command is repeated to establish the required priority is understood.»

Deck: "Drop-drop-drop." «Deck knows Lab is aware the drop command is for the profiler and provides a three-word repeat of the command to establish priority. Note the omission of the call sign sequence, which is not absolutely necessary, because it was already established in the initiating sequence above.»

Lab: "Roger that; Out." «Lab knows Deck understands the information exchanged only involves the drop command, which must be acknowledged, and now has nothing to do, so the conversation can be ended by the addressee.»

In this conversation, eighteen words are exchanged in just a few seconds.

- **Exercise 7.2** *What is the advantage of using laboratory cables for the functionality test?*

If the system configuration works with the laboratory cables, then when the system is tested after the field cables are installed and something is found to not work, it can safely be assumed that the fault is with one of the field cables.

- **Exercise 7.2.1** *If the deck box appears to be malfunctioning, what is a good way to record the messages generated by the deck box, so they can be studied more carefully and perhaps transcribed for the manufacturer?*



Most modern digital cameras have an option allowing the recording of a video or motion picture. This feature can be used to document the messages displayed by the deck box as they emerge during the power-up process. The individual frames can then be viewed (Fig. A4) and transcribed, if necessary.



**Fig. A4.** A single deck box panel display during a normal power-up sequence as recorded with a digital camera aboard the R/V *John Le Conte*.

If the ability to record a video is not an option, the individual messages can nonetheless be recorded as still pictures, which can be subsequently transcribed. The rate at which the messages emerge might require multiple attempts to capture all the messages. Comparisons of the transcribed messages with documentation provided by the manufacturer, as well as summary information in Sec. 7.2.1, might be sufficient to understand the fault condition and clear it.

► **Exercise 7.2.2** *What additional simple procedure can be used to verify the individual light instruments are responding as anticipated?*

An additional simple procedure to verify the individual light instruments are responding as anticipated can be executed in a well lit area or with the aid of a flashlight. Remove the cap off one of the instruments, illuminate the aperture (with the flashlight, if necessary), and verify that the computer display for that instrument shows elevated signals across all channels. Put the cap back on the sensor and verify the signals return to dark values. Repeat this process for each instrument.

► **Exercise 7.3** *What kinds of changes in solar illumination are acceptable on a moving platform?*

Slow and linear changes in solar illumination do not pose a data processing challenge. Consequently, the change in illumination from a varying solar zenith angle is not a problem on a moving platform nor is a slow brightening or darkening during overcast conditions. Rapid changes, as can occur when a small cloud moves across the solar disk or when the Sun emerges temporarily from an overcast condition, must be avoided.

► **Exercise 7.4** *When there are two sea-viewing options with BioSCAN, why is the position that has the sea-viewing instrument pointed farthest from the deployment platform selected?*

The position with the sea-viewing instrument pointed farthest from the deployment platform is preferred, because this position will have less chance of a platform perturbation than the alternative. An exhaustive analysis of platform perturbation effects is provided by Hooker and Morel (2003), Hooker et al. (2003), and Hooker and Zibordi (2005).

► **Exercise 7.5** *What is unusual about the configuration of the C-OPS profiler shown in Fig. 20 and what advantage does it provide?*

The unusual aspect of the C-OPS profiler in Fig. 20 is that no flotation disks are present (compare to Fig. 7). The hydrobaric buoyancy chamber has sufficient buoyancy that the profiler can be trimmed using weights alone. The advantage of this configuration is the backplane is more transparent to the swell, which means it is easier to haul in, it is less responsive to surface gravity waves, and it has a smaller shading cross-section.

► **Exercise 7.5.1** *What is a good habit to learn in order to overcome a common omission when preparing to deploy the C-OPS backplane, especially if there are unanticipated problems, that some software might not detect?*

A common omission when preparing C-OPS for deployment, especially if there are unanticipated problems that some software might not detect, is that the cap was left on the solar reference radiometer. A good habit to learn is to place all caps in the C-OPS instrument basket, and count them when the in-water radiometer caps are added to the basket, i.e., there should always be three caps.

► **Exercise 7.5.2** *If the maximum range of adjustable tilt in a particular direction has been achieved, but more tilt adjustment in that direction is needed, what can be done to provide the needed adjustment?*

To add to the maximum range of adjustable tilt in a particular direction, weight or foam flotation can be moved to the appropriate place on the backplane where extra tilting is desired. For example, if more negative pitch adjust is needed, weights can be moved to the inside of the bumpers on the negative pitch side of the backplane, so they are acting over a longer moment arm. The concept of having the flotation or weights repositioned so they act over a longer moment arm can be further augmented by adding more weight or flotation, but this will impact the descent rate.

► **Exercise 7.5.3** *What is the disadvantage in using propeller or thruster turbulence to move a profiler away from the ship?*

The disadvantage in using propeller turbulence to move a profiler away from the ship is it artificially mixes the water and introduces a significant amount of bubbles and foam (Fig. A5). A vertical profile cannot commence until

sufficient time has elapsed for the turbulence to dissipate, so normal water properties can be restored. The directed energy of the propeller aids in clearing the turbulence, but in some cases a significant amount of time must be devoted before profiling can commence.



**Fig. A5.** The C-OPS backplane in the thruster turbulence of the TR/V *Oshoro Maru* revealing the large amount of small bubbles formed as a result of using the bow thruster.

In shallow water, propeller or thruster turbulence can resuspend bottom material that will significantly alter the optical properties of the localized water mass. If there is little or no current, the overturning motions associated with the turbulence can persist for a long time, so extra caution is needed when maneuvering in shallow waters.

- **Exercise 8.0** *Are there circumstances wherein the safest place for the backplane is at depth, i.e., it should not be recovered?*

When the proximity of the profiler with respect to the deployment platform is unknown and sea surface conditions are very rough, the profiler is usually safer at an intermediate depth (i.e., between the surface and the sea bottom). Before recovery is attempted, the position of the profiler with respect to the deployment platform must be confirmed. If the profiler is being deployed from a ship, the intermediate depth should be between the keel and the sea bottom. The reason the profiler is relatively safer at depth is because there is usually nothing that the profiler can be thrown against to damage it, whereas at the surface there is the hull of the vessel.

The exception to this general rule is when the profiler is being deployed from an offshore structure, which will necessarily extend to the sea bottom, so there is no intermediate depth wherein the profiler cannot be thrown against the submerged parts of the structure.



*When deploying a profiler from an offshore structure, it is important to keep the profiler and cable*

*leading to the profiler in sight, to the greatest extent practicable, so there is continuing visual evidence that it is not becoming ensnared on a hidden obstruction.*

- **Exercise 8.1** *How should the BioSCAN frame be stowed if severe weather is anticipated?*

If severe weather is anticipated, the radiometers on the BioSCAN frame should be capped, removed, and dummy plugs affixed to the instruments as well as the Y-cable on the frame. If the frame is located on the bow or in the direction that severe weather is expected to come from, the cable leading to the Y-cable should be disconnected and a dummy plug affixed to both free ends. The resulting slack in the cable coming from the deck box should be coiled up and cable tied to a permanent fixture. Then the frame should be removed by unscrewing it from the pipe below the flange. The entire frame assembly should then be stowed and secured indoors.

- **Exercise 8.2** *If severe weather is expected, how should the C-OPS backplane be stowed?*

Whenever severe weather is expected, the C-OPS sea cable should be disconnected from the cable coming from the deck box and dummy plugs affixed to the free ends of both cables. The resulting slack in the cable coming from the deck box should be coiled up and cable tied to a permanent fixture. Then the cable bucket and C-OPS basket should be stowed indoors and secured.

- **Exercise 8.3** *How should the solar reference be stowed if severe weather is anticipated?*

In the event of severe weather, the BioMAST should be retracted. The cable from the deck box should be removed from the solar reference subsystem and dummy plugs affixed to the exposed bulkhead connector and the free end of the disconnected cable. The resulting slack in the cable coming from the deck box should be coiled up and cable tied to a permanent fixture. The radiometer should be capped, and the solar reference subsystem unscrewed from the 1 in pipe it is affixed to, and stored indoors.

- **Exercise 9.0** *If a cap is lost, what is a good substitute that can be obtained or fashioned in the field?*

A replacement cap can be fashioned using some lint-free cloth, aluminum foil, and black vinyl tape. The most difficult caps to replace are for radiance instruments, because on the C-OPS backplane and BioSCAN frame, these apertures have the least amount of exposed areas in their mounting systems. Consequently, if a radiance cap is the one that is lost, the irradiance cap should be moved to the radiance aperture in question and an irradiance replacement made.

To fashion the cap, cut a piece of cloth that is about 10 in (25.4 cm) square. Black or dark-colored cloth is preferred, but not required. Cover one half of one side of the

cloth with successive applications of lapped vinyl electrical tape, wherein each application is longer than the cloth, so the tape ends can be folded over the cloth ends. Roll the cloth loosely around the instrument with the vinyl side laid against the housing. Position the cloth cylinder such that it projects beyond the aperture, and then fold the extra cloth over the aperture. Tape the exposed outer cloth using vinyl electrical tape by applying it in successive lapped layers, being careful not to apply the tape too tightly, so the cap can be reliably positioned and removed.

Complete the cap by over wrapping all surfaces with aluminum foil. Cover the aperture end with overlapping layers of tape, and then finish the taping with a long circular application of overlapping tape layers from the bottom of the cap to the aperture end. Additional taping can be added to increase the relative stiffness of the cap. The cap should fit on with a bit of resistance, but not be difficult to slide on.

► **Exercise 9.1** *What is another name for self-fusing tape?*

Self-fusing tape is also known as self-vulcanizing, or simply vulcanizing, tape. Vulcanization, in this context, is the process whereby the tape hardens to provide the needed final elasticity, strength, and stability properties without the need for adding any secondary agents (e.g., chemicals or heat).

► **Exercise 9.2** *Why is containerizing spares and tools important to successful problem solving?*

During a field campaign, there is frequently a limited amount of time between the onset of a problem and the needed resolution before the next sampling opportunity. This means problems necessarily require prompt solutions. In this situation, time spent looking for tools or spares is time that is wasted on not solving the problem, so a sensible system that facilitates finding spares and tools is an advantage.

► **Exercise 9.2.1** *Why is it desirable that certain tools appear in more than one tool inventory?*

Any tool that is used for a multitude of tasks should be present in more than one tool bag, because by definition, its loss will be an inconvenience and one or more spares are needed. The most recurring hand tool that is needed with spares is a pair of diagonal cutters.

► **Exercise 9.2.2** *How is a small cable tie used to secure a shackle pin?*

To keep a shackle pin from loosening, a small cable tie is fed through the shackle pin eye and then it is looped around the shackle pin and tightened (Fig. A6). For the anticipated uses of shackles described here, the use of a cable tie for immobilization is preferred over a stainless steel wire, because a twisted wire usually produces very sharp edges that can cut or puncture the skin.



**Fig. A6.** A small cable tie fed through the shackle pin eye and looped around the shackle pin on the C-OPS harness to prevent the shackle from coming loose during deployments aboard the R/V *Shearwater*.

► **Exercise 9.2.3** *Why is a handheld GPS useful even if a BioGPS is part of the instrumentation?*

The handheld GPS is used to set UTC time on the data acquisition computer (at least on a daily basis) and for geolocation coordinates if the BioGPS is not part of the reference subsystem. Even if a BioGPS is available, it is not always easy to set the computer clock with the BioGPS display in the data acquisition environment (although it is possible with practice).

► **Exercise 9.2.4** *If an underwater cable is damaged, why is it important to not deploy it to depth?*

An underwater cable that is damaged should not be deployed to depth, because the increased pressure might force water into the interior wraps of the cable, which will waterlog it (make it heavier) and possibly lead to corrosion. If a cable is damaged at depth and then brought to the surface, any repairs will have to include an investigation as to how far water penetrated into the cable above and below the point of damage. In many cases, a significant amount of cable will have to be thrown away to remove the waterlogged portions.

► **Exercise 9.2.5** *What is a cable pigtail?*

A cable pigtail is a short length of cable, usually 18 in (0.5 m) long, with a connector at one end. A pigtail is also referred to as a *whip* and is intended to be used to repair the end of a damaged cable or create an unanticipated cabling configuration.

► **Exercise 9.3** *Why are daily activities so important to routine maintenance?*

Daily activities are important to routine maintenance because they provide a recurring opportunity to inspect the equipment and determine if repairs are necessary.



- **Exercise 9.3.1** *What other sources of airborne particulates can be deposited on the solar reference aperture?*

Other sources of airborne particulates that can be deposited on the solar reference aperture include, but are not limited to, the following: a) most large vessels have an incinerator and the burning of trash can add to the amount of soot deposits; b) there are areas of the world ocean wherein plumes of desert dust are transported out to sea and these deposits can be significant (they are frequently easily identified by their red-brown color); c) in coastal areas deposits from industrial areas can be substantial; and d) the sea surface, especially when breaking waves and white caps are present, is a recurring source of particles. Consequently, if an instrument aperture is not collecting data, it should be kept capped to ensure cleanliness.

- **Exercise 9.3.2** *Why are threads that fasten dissimilar metals greased with Dow 111?*

Threads that fasten dissimilar metals should be greased with Dow 111, because it is a dielectric compound, which means it will help prevent the galvanic corrosion that takes place between dissimilar metals.

- **Exercise 9.3.3** *What are some cautions that must be observed when removing fasteners that have held fast for a long time without being tightened or loosened?*

A fastener held fast for a long time may be partially seized, which means the head of the fastener can round out when the tool to remove the fastener is used. It is important to grip the tool being used firmly, and apply a strong downward pressure, before attempting to loosen the fastener. If the fastener does not initially release, an anti-corrosion and rust breaking lubricant should be applied to the fastener, e.g., Break Free CLP (Safariland, Jacksonville, Florida), and a sufficient amount of time needs to be provided for the lubricant to work into the threads. If possible, the lubricant should be applied at more than one point (e.g., if the fastener is through bolted, lubricant should also be applied at the end of the through-bolt threaded hole and the end of the fastener).

- **Exercise 9.4** *Why should scratched anodized aluminum be painted promptly?*

Anodized aluminum should be painted promptly if it is scratched, because the freshly exposed metal will become the point for galvanic corrosion for the entire piece of metal.

- **Exercise 9.5** *Why is a scratched aperture a concern?*

A scratch on an aperture creates uncharacterized scattering of light. Depending on the severity of the scratch, it can invalidate the calibration of the instrument.

- **Exercise 9.6** *What is another safe technique for measuring signals on female sockets?*

A smaller conductor, like a paper clip or smaller gauge solid wire, can be attached to the voltmeter probe, e.g., by using a wire with alligator clips on the ends.

- **Exercise 9.7** *What is a common mistake when applying heat-shrink tubing that must be avoided for splices that will be submerged to depth?*

When heat-shrink tubing is applied it is important to apply the heat starting at one end, and then slowing working towards the other end. If this is not done, air bubbles can be trapped inside the tubing. When a bubble is subject to pressure at depth, water can ingress into the collapsing air volume.

- **Exercise 10.0** *How does labeling the contents of boxes aid demobilization?*

Labeling the contents of boxes aids the demobilization process, because it provides guidance as to what equipment should be packed in which containers. This can save time, which is frequently needed, because modern field campaigns frequently have inadequate time allotted for demobilization.

- **Exercise 11.0** *What other activity should be synchronized with long-term storage?*

It is advantageous to conduct all periodic maintenance prior to long-term storage. This will ensure the equipment is in a known state of serviceability at the time of storage, which means corrosion during storage (if any) can be properly assessed.

- **Exercise 12.0** *Why are the limits and cautions of a small craft advisory useful to understand even on a large deployment platform?*

A small craft advisory is useful to understand even on a large deployment platform, because it indicates a sea state that will likely be hazardous for instrument deployments. Whenever a small craft advisory occurs, personnel should exercise extra caution regardless of the size of the deployment platform.

- **Exercise 12.1** *If the tow vehicle meets all trailering requirements except the tow ball is not at the correct height above the ground, what is a possible solution?*

If the trailer hitch uses a removable (rather than fixed) receiver, an adjustable receiver can be used instead, and the correct height selected from the range of possibilities.

- **Exercise 12.2** *If the vehicle mirrors are used for backing up a trailer, what precaution should be followed in regards to steering the vehicle?*

Backing up a trailer can be confusing, because the steering wheel must be turned opposite to the desired turning of the trailer, i.e., if the steering wheel is turned to the right (CW), the end of the trailer will track to the left (and vice versa). If this process is executed while looking through the vehicle mirrors it can be doubly confusing. The precaution that should be followed is to make small course corrections until sufficient experience is gained.

► **Exercise 12.3** *What is one of the difficulties of using safety equipment on a small boat?*

Small boats are frequently cramped and wet, so safety equipment must frequently be stowed to protect it, which makes it less accessible.

► **Exercise 12.3.1** *What common accident might render an inflatable PFD ineffective for the person wearing it?*

⚠️⚠️⚠️ *If a person wearing a PFD is knocked unconscious and falls overboard, it is unlikely the PFD will function as intended.*

► **Exercise 12.3.2** *Although designed for safety purposes, what are some posed by fire extinguishers?*

⚠️⚠️⚠️ *Halon fire extinguishing agents may cause toxic fumes or be lethal; halon discharged in closed spaces consumes the available oxygen and persons should be evacuated immediately; and CO<sub>2</sub> is discharged at sub-zero temperatures and the operator may be injured if contact is made with the horn of a portable CO<sub>2</sub> extinguisher.*

► **Exercise 12.3.3** *What is a sensible use for an expired VDS?*

An expired VDS may be retained as additional backup, or used for inland waters (in some states).

► **Exercise 12.3.4** *For small-boat operations, what commonly available sound signaling device can be used?*

An athletic whistle is an acceptable signaling device for small-boat operations.

► **Exercise 12.3.5** *What are the operating requirements for a small boat having installed lights that are not required?*

If lights are installed on a boat that does not require them, they must work properly.

► **Exercise 12.3.6** *What is a kill-switch mechanism?*

A kill switch is an engine ignition switch wherein the key can be removed at any position. If the engine is running when the key is pulled out, the engine immediately stops. For this feature to be useful, the boat operator usually wears a lanyard looped around a wrist with the other end of the lanyard attached to the key.

⚠️⚠️⚠️ *If the boat operator is knocked down—perhaps overboard—the engine stops.*

► **Exercise 12.4** *If a separate 12VDC AGM battery is brought for the optical sampling, should it be kept separate or wired to the starting battery for the engine?*

⚠️⚠️⚠️ *In terms of boating safety, it is advisable to not use the designated starting battery for any other purpose other than starting the engine.*

If the capacity of the starting battery and second battery are high, the two can usually be wired together for a single battery having greater capacity. The advantage of this approach is that when the engine is running and providing a charge, both batteries will be charged.

Two batteries can be connected either in series or in parallel (Fig. A7). When wired in series, the net voltage is the sum of the two batteries, whereas the capacity is the average of the two; when wired in parallel, the voltage is the average of the two batteries, and the capacity is the sum.

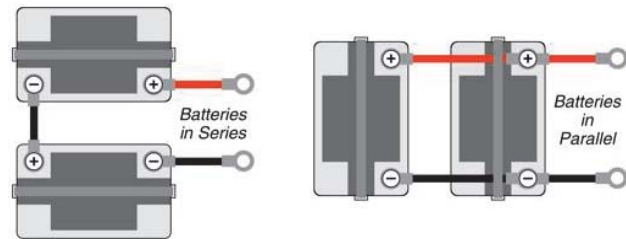

**Fig. A7.** The two standard configurations for connecting two batteries: **a)** in series (left), and **b)** in parallel (right).

For the case of adding a second battery to a small boat, the two batteries should have comparable capabilities (i.e., both should be starting or deep cycle batteries), similar capacities (i.e., the same VA or Ah ratings), and they should be wired in parallel (Fig. A7b). This allows both batteries to be charged when the motor is used. Although there is a risk for draining both batteries with excessive data acquisition, this is easy to prevent for the type of sampling documented here, wherein data collection is over a very short time period (usually less than 30 min).

► **Exercise 12.5** *How can the requirement for proper trash disposal aboard a vessel be used to advantage?*

Use a container that can be draped over or positioned on top of other equipment to provide water proofing.

► **Exercise 12.6** *What is a disadvantage of the bar-stool surface reference mounting system?*

A disadvantage of the bar-stool surface reference mounting system is the presence of the four stabilizing lines, which can interfere with operations inside the boat, although Fig. 39 shows this disadvantage can frequently be accommodated.

- **Exercise 12.7** *Why is it important to launch a boat as unloaded as practical?*

It is important to launch a boat as unloaded as practicable, because it will float free from the trailer sooner. This means the trailer does not have to be backed as far into the water and the vehicle will be far enough up the boat ramp to have good traction.

- **Exercise 12.8** *What is a common restriction on boat handling within a marine facility, channel, or bridge?*

When navigating in a marine facility, a channel, or under a bridge, the boat operator should adhere to a speed that is slow enough to leave “No Wake” (which is frequently posted for these circumstances).

- **Exercise 12.8.1** *What is the memory mnemonic regarding navigation markers and a vessel returning to the dock?*

When a vessel is returning to the dock, red navigation markers are on the starboard (right) side of the boat or red right returning.

- **Exercise 12.8.2** *Given the description of a small boat for this document, what priority will typically be assigned to a small boat for right-of-way purposes?*

A small boat as described herein will typically have the lowest priority and must yield the right of way under most circumstances.

- **Exercise 12.8.3** *If the shortest course to the nearest harbor results in a rough ride and water splashing into the boat, what should the boat operator do?*

If the shortest course to the nearest harbor results in a rough ride and water splashing into the boat, the boat operator should *fall off* the desired course and follow a course that is in the general direction of the harbor, but that provides a smoother ride and less water splashing into the vessel. At some point, the operator will have to turn away from the desired course and *tack* towards the harbor until the smoother course can be aligned with the harbor entrance. In some cases, more than one tacking maneuver will be required.

- **Exercise 12.9** *What is the best position for the person operating the C-OPS backplane during small-boat operations, in terms of the stability of the vessel?*

The C-OPS backplane is typically deployed, positioned away from the vessel, and recovered with the operator standing up. Once casts are commenced it is advantageous for the operator to be seated, because it creates less ship motion, which is beneficial for the solar reference measurements and the data acquisition computer operator.

- **Exercise 12.9.1** *If only two people are available for small-boat operations, what are the safest assignments for the three tasks involved (boat handling, instrument operation, and software control)?*

If the boat can be anchored, the boat does not have to be steered, so one person can deploy and recover the instrumentation, and the other person can operate the data acquisition software.

If the boat cannot be anchored, one person must handle the boat and the other person must deal with the data acquisition, as well as instrument deployment and recovery. A recommended set of procedures, based on a slow descent rate for the profiler (i.e., a terminal velocity of  $15 \text{ cm s}^{-1}$  or less) is as follows:

1. Start recording the data.
2. Deploy the backplane and float it away from the deployment platform.
3. Once the backplane is far enough away to avoid platform perturbations, pull out the amount of cable equal to the desired depth from the cable bucket.
4. Release the cable and as the profiler descends, estimate the amount of cable used since the release as a proxy for the depth of the profiler and verify this corresponds with the amount of cable pulled from the bucket (i.e., the cable out of the bucket should be consumed when the desired depth is reached).
5. Pull the profiler back to the surface and repeat the process for as many times as needed (usually three times).
6. Recover the profiler and stop recording the data.

This scenario assumes the single data file can be split into the requisite number of individual casts, which should usually be three.

- **Exercise 12.9.2** *In areas of high heterogeneity or if the desired three casts cannot be obtained quickly, how should the sampling strategy be modified?*

In areas of high heterogeneity or if the desired three casts cannot be obtained quickly, a second set of three casts is advised after the water sample, so the optical sampling temporally brackets the water sample.

- **Exercise 12.10** *What should be the course of action if one of the trailer lights stops working after being submerged to launch or retrieve the boat?*

If a trailer light stops functioning as a result of being immersed in water, remove the lens, remove the bulb and verify it is not blown (if it is blown, replace it), and then rinse the bulb and interior of the light assembly with fresh water. Wipe everything dry and inspect for corrosion. If corrosion is present, scrape it loose, and rinse with fresh water, and wipe dry. Insert the bulb and test. If it does not work, replace the bulb.



APPENDIX B  
FREQUENTLY ASKED QUESTIONS (FAQs)

**FAQ 1.** *What are the principal differences between the C-OPS and a legacy rocket-shaped profiler?*

The C-OPS instrumentation represents a significant improvement over legacy profilers which are not suitable for shallow-water sampling or for determining the optical properties of near-surface waters. The C-OPS backplane was designed from inception specifically to operate in shallow coastal waters while maintaining an equal capability to sample in the deep ocean (Hooker et al. 2010a).

In terms of the mechanics of operating the instrumentation and its behavior during descent, the most significant improvement was to change the basic design for mounting the light sensors from a rocket-shaped deployment system, used in legacy profilers, to the kite-shaped backplane. This change allowed the flotation to be distributed as a primary hydrobaric buoyancy chamber along the top of the profiler (Fig. 7l), plus an adjustable secondary set of one or more movable floats (Fig. 7m) and weights below (Fig. 7p).

The primary flotation set provides the upward buoyant thrust to keep the profiler vertically oriented. The secondary set, coupled with an adjustment mechanism perpendicular to the flotation adjustment axis (Fig. 7h) is used to ensure the two optical apertures are level. The hydrobaric buoyancy chamber can contain one to three air-filled bladders, which compress slowly and allow the profiler to loiter close to the sea surface, thereby significantly improving the vertical sampling resolution in near-surface waters to 1 cm or less.

For deep-ocean sampling, three compressible bladders are typically used, because once the bladders have compressed, the maximum amount of differential ballast is available to drive the profiler downwards at a high terminal velocity (usually 25–50 cm s<sup>-1</sup>). A higher rate of descent is attractive because it minimizes how much cable is consumed by horizontal advective processes rather than vertical descent. In a shallow river, either less positive buoyancy is used (i.e., some weight is removed) or a smaller number of bladders and less weight are used to establish a smaller ballast differential (thereby achieving a typical descent rate of 10–25 cm s<sup>-1</sup>).

With respect to a legacy profiler, C-OPS records greater than a factor of 10 more samples in the near-surface 5, 10, and 15 m of the water column because of its surface loitering, slower descent rate, and higher acquisition rate (12–15 Hz versus 6 Hz or less). This means C-OPS sampling captures the high-frequency perturbations associated with wave-focusing effects (Fig. B1), thereby minimizing the aliasing normally encountered with legacy devices for this phenomenon that can significantly degrade the ability to establish the extrapolation interval in near-surface waters, particularly if the water is very clear. The high vertical resolution also means the presence of thin intrusive

layers (perhaps of freshwater origin from rivers or melting ice) are properly sampled for the first time in a freely falling package.

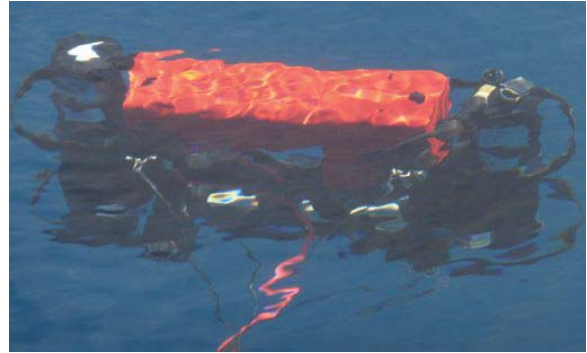

**Fig. B1.** Wave focusing effects on the primary flotation of the C-OPS backplane deployed from the R/V *John Le Conte* in Lake Tahoe.

From an electronics point of view, the biggest difference between C-OPS and legacy instruments is the use of microradiometers (Booth et al. 2010) to build the optical instruments. The microradiometer approach established—for the first time in oceanographic optical instrumentation—a single-instrument design with inherent flexibility and dynamic range (10 decades) as to be scalable across all the sampling requirements for both above- and in-water AOP measurements (Morrow et al. 2010c).

*A microradiometer has components so small they must be machine assembled.* The outer diameter of 1.1 cm is set by the photodetector, and after the fore optics and metal shielding are applied the overall length is 9.6 cm. Automated production with conformal coating of the electronics removes almost all of the instrument-to-instrument performance variability that had plagued handmade legacy instruments.

**FAQ 2.** *What are the quantitative electrocution effects for a man exposed to 60 Hz AC current?*

The sensitivity to electrocution effects for AC current is more pronounced than for DC current, in terms of the thresholds for which the same quantitative effects are experienced (Sect. 2.2). For a man exposed to 60 Hz AC current, the approximate quantitative effects are as follows:

- 0.5 mA A slight sensation (tingling) on the hand is felt;
- 1 mA The perception threshold, i.e., the accepted maximum harmless current, is reached;
- 5 mA A shock with no loss of muscular control occurs;
- 9 mA A painful shock with 50% loss of muscular control is experienced;
- 15 mA The “let-go threshold” (i.e., the current value above which a person is unable to release an electrically energized source because of involuntary muscle contractions) is reached; and

35 mA A painful and severe shock with difficulty breathing and more than 99% loss of muscular control is experienced.

The quantitative effects of AC current thresholds for a woman are about 70% of a man.

**FAQ 3.** Explain the truth and fallacy of the old adage, “It is not the voltage that kills, it is the current.”

⚡⚡⚡ Electric current can burn tissue, create a loss of muscular control (which can result in other injuries, including broken bones), and cause cardiac arrest or arrhythmias†.

Current can only enter the body, however, if the amount of voltage applied between two points on the body is sufficient to allow electrons to flow between the two points despite the resistance of body parts to oppose the flow of electrons. In an electrical shock, the amount of electrical current (in amps) that flows through a body of constant resistance (in ohms) increases when the voltage (in volts) increases. This is a restatement of Ohm’s law,  $I = V/R$ , where  $I$  is current,  $V$  is voltage, and  $R$  is resistance.

Following Ohm’s Law, anything that lowers the resistance of the body (e.g. wet skin or an open wound) or enhances current flow (e.g., metal jewelry) will increase the current if the voltage remains constant. Similarly, the higher the voltage available to cause electrons to flow, the more readily they will flow through any given amount of resistance and the more likely the current level will be high enough to be harmful.

⚡⚡⚡ Consequently, the danger of high voltage is it represents a potential for large amounts of current to pass through the body, which can injure or kill. A worst-case scenario is a shock between the hands, because the current path from one hand to the other is across the heart and lungs.

A common practice to protect the heart when working around a live circuit is to use only one hand and to place the other in a pocket. The right hand is preferred, because most people are right handed and the heart is left of center in the chest cavity. The best protection against shock from a live circuit is resistance, and resistance can be added through the use of insulated tools and clothing (e.g., gloves and boots), but they must not provide a secondary conduction pathway (e.g., from water) to be fully effective. Resistances are additive, so by Ohm’s law, an increase in resistance will lower the current that can flow for a particular voltage source.

† The heart has an internal electrical system controlling the rate and rhythm of the heartbeat. An electric shock can create problems with this electrical system resulting in abnormal heart rhythms (arrhythmias) or the heart suddenly not beating (cardiac arrest). There are many types of arrhythmias, wherein the heart can beat too fast, too slow, or irregularly. Some arrhythmias can cause the heart to stop pumping blood. If the blood cannot carry oxygen to the brain, brain death occurs in about 3–4 min. Normal heart rhythm is restored with another electric shock, from a defibrillator.

**FAQ 4.** How is it possible to tell which end of a mated cable connection goes to the deck box?

The deck box provides power, so the cable end coming from the deck box will have a female connector so it can safely supply power. When two cables are mated, one side will have a female connector with female locking sleeve (i.e., it will be FS/FG) and the other will have a male connector with male locking sleeve (i.e., it will be MP/MR). The female half of the mated pair is identified by the larger locking sleeve, as shown in Fig. 4 (bottom) and Fig. B2, and this connector leads back to the deck box. Consequently, in Fig. B5, the cable leading back to the deck box is the one with the small reveal of orange tape on the left side of the figure.

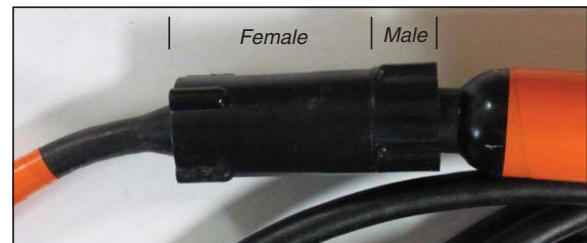

**Fig. B2.** Two mated connectors with the female connector on the left and the male connector on the right aboard the R/V *Tethys II*.

**FAQ 5.** What are the components and types of stainless steel and why do they not rust?

The “stainless steel” designation is a misnomer, because the material is not made from steel—it is an iron-based metal that has at least 10.5% chromium. Other alloying elements, e.g., nickel, molybdenum, and manganese, are added to achieve specific corrosion resistance and physical properties. The combinations of the different alloys results in over 100 different kinds of stainless steel.

Only a few of the stainless steel grades are routinely used, however, with 304 SS being the most popular grade. The 300 series designation indicates the grade is composed basically of 18% chromium and 8% nickel. Consequently, 304 SS is also referred to as 18-8 SS or 18/8 SS. It is sufficiently corrosion resistant for common applications, is not magnetic, and cannot be hardened by heat treatment.

The next most popular grade of stainless steel is 316 SS, which contains a lesser amount of chromium (16%), but a greater amount of nickel (10%) and an additional amount of molybdenum (2%). The added alloying with respect to 304 SS increases the resistance to salt corrosion, which makes 316 SS very suitable for marine applications. To ensure quality and protection for the consumer, all products made with 316 SS must be marked “316” by the manufacturer.

The 400 series has less corrosion resistance than the 300 series. These stainless steels contain only one alloy, chromium, and are magnetic. The chromium content of

the three principal types are 16% (430 SS), 11.5% (410 SS), and 10.5% (409 SS).

Stainless steel does not rust, i.e., the red iron oxide discoloration that is normally seen on carbon steel is not present, because stainless steel contains chromium and has a very low carbon content (compared to mild steel). The chromium combines with airborne oxygen to form a very adherent surface film that resists further oxidation. No iron is oxidized, so no red rust is present.

**FAQ 6.** *Can the cabling assignments for the two ports on the deck box be switched (i.e., can the sea cable be attached to port 2 and the solar reference to port 1)?*

From the perspective of the deck box, cable assignments to the deck box ports can be reversed without harming any of the instrumentation and without compromising the ability of the deck box to determine the correct operating voltage for the cable lengths associated with either port.

Some acquisition software, however, may require the port assignments to be correct as a way of determining incorrect configurations of the instrumentation, so it is advisable to connect the cabling to the labeled port assignments. As shown in Fig. B3, it is helpful to use color coding on the deck box and cabling to facilitate correct connections to the deck box and this practice should be continued all the way to the instrument bulkhead or Y-cable (as appropriate).



**Fig. B3.** Cable connections to the deck box with port 1 (underwater) labeled blue and port 2 (surface) labeled orange aboard the R/V *Hakuho Maru*.

**FAQ 7.** *How long can a C-OPS configured with three 19-channel  $E_d$ ,  $L_u$ , and  $E_d(0^+)$  instruments, plus a BioSHADE and BioGPS, operate on the deck box battery?*

Longevity of battery operations depends more exactly on the total length of the cables and the number of times the BioSHADE accessory is used (which consumes the most power). For a 150 m sea cable and 25 m reference cable, the deck box battery will power the optical subsystems for approximately 5 hr at a 100% duty cycle.

**FAQ 8.** *What can be used to protect the sea cable from chaffing, when it is hauled in over the gunwale of a ship?*

Most vessels wherein this is likely to be a problem will have a roller assembly that can be mounted on the gunwale. The assembly provides perpendicular rollers that provides curvature at the edge of the gunwale and motion to absorb the strain of pulling on the cable (Fig. B4). If such a device is not available, a suitable synthetic material that allows the cable to move easily without binding on the metal gunwale can help protect the cable.



**Fig. B4.** A roller assembly to protect line or cable when hauled aboard the TR/V *Oshoro Maru*.

**FAQ 9.** *What does wave focusing and ship shadow look like in an optical profile, so the latter can be recognized during data acquisition and the cast repeated if so contaminated?*

Wave focusing is represented in an optical profile as high amplitude light-to-dark excursions in the data, for which the amplitude of the phenomenon decreases with depth. Although it might look like noise, wave focusing is not noise, because the light and dark flashes are not the result of a signal-to-noise problem, they are the correct record of a real phenomenon. Ship shadow appears as a typically large extent of anomalously darkened data that ultimately brightens with depth and the profile resumes a normal decay.

If the ship-shadow contamination begins at the surface, the profile will steadily brighten until the profiler reaches a depth wherein there is no ship shadow, and then a typical decay will resume. The depth interval where ship shadow is replaced by normal decay is characterized by a reversal in the spectral  $K_d$  values from negative to positive values.

Figure B5 presents a portion of a PROSIT data processing display showing the upper 5 m of an  $E_d$  profile containing both wave focusing effects and ship shadow contamination. The wave focusing appears from 0–2 m, and



the ship shadow starts a little before 3 m and extends a little past 4 m. The black diagonal lines are the slopes of the linear least-squares fit to the extrapolation intervals established for red and blue-green wavelengths (left and right, respectively). The ship shadow contamination cannot likely be explained by an unusual set of layers with anomalous properties, because the temperature data (not shown for clarity of the optical wavelengths) shows the upper 5 m was homogeneous.

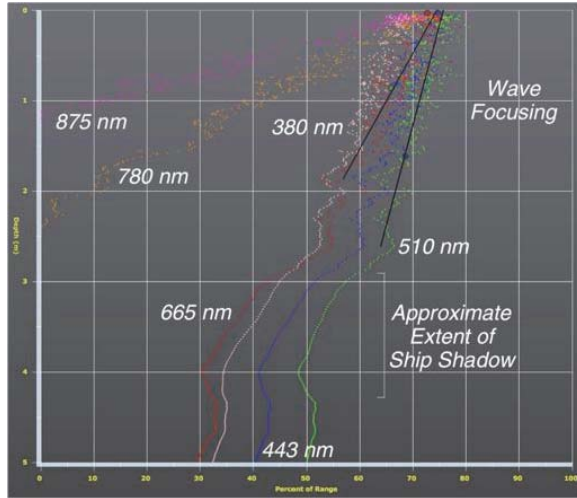

**Fig. B5.** An example of wave focusing and ship shadow contamination for the top 5 m of an  $E_d(\lambda)$  profile obtained aboard the TR/V *Oshoro Maru* in the Chukchi Sea. The temperature data are omitted and only a subset of wavelengths are shown for clarity.

**FAQ 10.** *How else have microradiometers been used to create new instrument systems?*

Since being field commissioned in 2009, microradiometers have been used in the following COTS instruments: a) the above- and in-water BioSCAN and C-OPS, respectively (documented here); b) the in-water Impacts of Climate on Ecosystems Profiler (ICE-Pro); c) the above-water and laboratory instruments for the Optical Sensors for Planetary Radiant Energy (OSPRey) activity; and d) the airborne Coastal Airborne In-situ Radiometer (C-AIR), which was flight certified by NASA aboard the Center for Interdisciplinary Remotely-Piloted Aircraft Studies (CIR-PAS) Twin Otter aircraft.

The microradiometer architecture facilitates hybridization with another technology. For example, a principal objective of the OSPRey project was to integrate a microradiometer cluster of 19 or 18 wavebands (depending on the radiance or irradiance model) with a spectrograph to form the first so-called *hybridspectral* instrument, thereby capitalizing on the best features of both technologies.

The microradiometer has also been used to expand AOP systems to include a novel inherent optical properties (IOPs) *hybridmetric* instrument, the Transfluorometer Two-Emission Extension (TF2E). The TF2E uses a

small LED in a form factor and firmware configuration compatible with a microradiometer to provide an excitation wavelength, and the emission of the water volume is measured with two traditional microradiometers (in the radiance configuration).

The use of one or more compatible LED microradiometers has been proposed for bio-fouling mitigation in longer-duration deployments of optical instruments as part of the Passive and Active Radiometers for Advanced Light, Ecosystem, and Littoral Studies (PARALELS) project. In this application the LED operates on an appropriate duty cycle to prevent bio-fouling.

A hybrid microradiometer technology is presently under development as part of the Ocean Color Underwater Low Light Advanced Radiometer (OCULLAR) Project that pairs a silicon photodetector (SiP) microradiometer with a photomultiplier tube (PMT) microradiometer, as shown in Fig. B6. The resulting *hybriddynamic multitector* increases the paired sensitivity an estimated six additional decades, with two decades overlapping, yielding 14 decades of linear dynamic range in a form factor compatible with standard microradiometers.

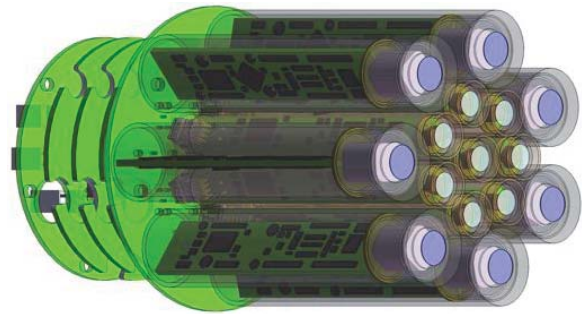

**Fig. B6.** A concept schematic of an OCULLAR hybriddynamic multitector instrument with a cluster of eight smaller SiP microradiometers in the interior, seven of which are paired to the slightly larger PMT microradiometers on the exterior circle. The small round left-most (green) boards are the so-called aggregators that allow the cluster of paired SiP and PMT microradiometers to be controlled as a solitary device.

Low-light measurements (Fig. A2) have the potential to expand the temporal and geographic capabilities of NASA missions to include historically undersampled regimes, e.g., large solar zenith angles or high latitudes late or early in the year. The large-angle domain is also relevant to the viewing geometry problems that will need to be addressed for geostationary missions, such as GEO-CAPE, so the research associated with deriving high-quality data products at large angles has a broader relevance.

Increasing the dynamic range of the *in situ* instruments will overcome present limitations and allow the pursuit of unprecedented new science. For example, diurnal processes in the ocean and atmosphere can be studied optically using moonlight as the light source. The ability to make low-light

measurements means high latitude processes can be investigated during the substantial time of the year when illumination is restricted to twilight, moonlight, or low solar elevations. Other areas of new research using OCULAR sensors include the study of coral spawning, plankton vertical migration, bioluminescence, and light-dependent predation (e.g., by tuna and squid).

**FAQ 11.** *What is a chinese finger, what does it look like, and how does it function?*

A chinese finger is a woven lacing strung securely over a cable with crossings that increase in distance from one another away from the cinch point. The cinch point usually has a loop with a shackle, and when tension is applied to the shackle, the lacings tighten on the cable, becoming tighter as tension is increased.

For C-OPS, a chinese finger is used to prevent tensile forces being applied to the connector and locking sleeve on the Y-cable connected to the sea cable on the backplane. This is accomplished by transferring the load from the sea cable to the backplane harness which is connected to the chinese finger using a shackle (Fig. B7).



**Fig. B7.** The chinese finger on a C-OPS sea cable deployed from a small inflatable launched from the R/V *SRV-X* into the Chesapeake Bay.

To ensure the sea cable below the chinese finger does not come under tension, a range of motion for the slackened sea cable is required, which results in a catenary that is visible in Fig. B7 as a drooping loop of red sea cable. The details of the chinese finger are not readily discernible in Fig. B7, but the mesh-like details of the chinese finger material is visible in Fig. A6, which shows a close up of the shackle connected to the two harness straps. The amount of cable in the catenary must be appropriately minimized so the weight of the shackle does not pull it into the FOV of the radiance radiometer.

**FAQ 12.** *What is a simple way to create a flexible spar and add weight to it?*

A large reusable cable tie, i.e., one wherein the head has a releasable lock for the tape, can be used to create a flexible spar. In this case, the tape end is pushed through

the spar fitting point (Fig. 4q) and the head end is blocked. Large stainless steel nuts wrapped in black vinyl electrical tape can be used as weights, which are secured to the flexible spar by two reusable cable tie heads (cut from two other cable ties). Two cable tie heads are used for security. An example configuration of this approach is shown in Fig. B8.

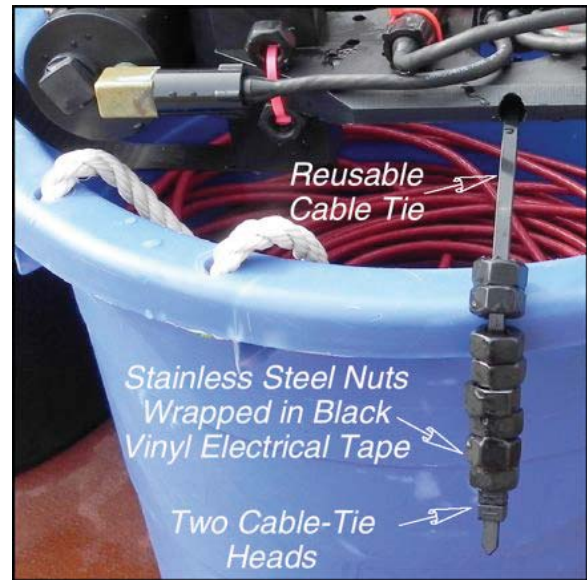

**Fig. B8.** The flexible spar on an early version of the C-OPS backplane deployed from the ASB launched from the USCGC *Healy* in the Chukchi Sea.

The stainless steel nuts are not in the FOV of the radiance sensor, but if they are not covered in black tape, they can scatter light into the FOV, so it is important to blacken them in some fashion. As described in Sect. 3.3, an advantage of this approach is it increases the righting response of the backplane, because the lower weights apply a downward stabilizing force.

**FAQ 13.** *What additional information regarding the atmosphere can be derived from BioSHADE measurements (depending on how the measurements are made and their frequency of collection)?*

The main purpose of the BioSHADE accessory is to provide measurements of the optical properties of the atmosphere and, in particular, to allow the calculation of the direct-horizontal and direct-normal spectral irradiance (i.e., the irradiance on a horizontal plane from direct solar illumination). Langley plots from irradiance data collected with the BioSHADE accessory can also be used to determine the extraterrestrial direct-normal irradiance and the aerosol optical depth.

**FAQ 14.** *When cable is flaked onto the deck of a deployment platform, what does it look like and why is it done?*

Cable is flaked onto the deck of a deployment platform in anticipation of a deployment scenario requiring the immediate use of a long length of cable that must go over the side quickly without entanglement. For example, if the C-OPS instrument is pushed away from a ship using turbulence from a thruster, the profiler will rapidly move away from the ship once the thruster is activated, which means a long length of cable is needed to ensure maximum benefit from the thruster is obtained.

The flaking of cable is usually accomplished by laying the needed length of cable in long lines formed into parallel loops (Fig. B9). Lines are used rather than coils, because the lines can be quickly confirmed to be tangle free, whereas coils cannot. Also, the lines give notice to deck personnel to stay clear of the area and, thus, the cable.



**Fig. B9.** The C-OPS instrument awaiting deployment (upper left) with the sea cable flaked onto the deck of the TR/V *Oshoro Maru* in the Bering Sea.

In rough seas, flaked cable can move, pile up, and be difficult to handle smoothly as the ship pitches and rolls. This is not as limiting as it sounds, because at some point operations are too rough for hand deployment of the profiler and deck operations will be suspended.

**FAQ 15.** *What commands can be sent from a terminal (or serial communications) interface to confirm a fault is with the acquisition software and not the instrumentation?*

If there is concern that there might be a fault with the system, all components should be powered down and restarted, including the data acquisition computer. Each component should be monitored during the power-up sequence to detect any anomalies. For the deck box, Sect. 7.2.1 should be consulted to confirm the messages on the deck box display are as anticipated for the system.

If the fault condition persists, the ensuing steps can be used to determine if the fault is not with the instrumentation and, thus, likely with the acquisition software.

1. Use a terminal emulation software program, wherein an RS-232 serial connection is made from a computer

terminal (or console) to the deck box. The command and control parameters should be set as follows for the selected communications port on the computer:

- 115,200 bits per second (baud rate);
  - 8 data bits;
  - No parity bit (i.e., none);
  - 1 stop bit; and
  - No flow control (i.e., none).
2. Send >OE! to the deck box and the reply should be <OE. If there is no reply, confirm that the terminal is accepting key strokes. The terminal might not be accepting key strokes because of one or more of the following:
    - a) a difference in the required baud rate and the bits per second value being used;
    - b) a bad console cable; or
    - c) the scroll lock option is enabled on the keyboard (if present, make sure the scroll lock key is disabled on the keyboard).
  3. Probe each instrument using the >␣I! command, wherein the “␣” character is replaced with an instrument address number of 0, 1, 2, 3, 5, 7, or 8 corresponding to the following with the reply also given for 19-channel radiometers (the typical case) with pressure transducer, water temperature sensor, BioGPS, and BioSHADE:
    - 0 The deck box, reply <0I,6,123578;
    - 1 The EdZ instrument (in-water downward irradiance), reply <1I,19,ABCDEFGHIJKLMNOPS;
    - 2 The LuZ instrument (in-water upwelling radiance), reply <1I,19,ABCDEFGHIJKLMNOPS;
    - 3 The Ed0 instrument (above-water solar reference), reply <3I,21,ABCDEFGHIJKLMNOPS [, ], where [ is pressure and ] is water temperature;
    - 5 The CAPS instrument (in-water temperature and conductivity accessory), reply >5I,3,CDS;
    - 7 The GPS instrument (BioGPS), reply <7I,1,\@; and
    - 8 The Shad instrument (BioSHADE accessory), reply <8I,1,/.

If the anticipated reply is not received for any of the instrument components, there is a fault condition with that component that must be resolved.

**FAQ 16.** *Can the C-OPS backplane be used in extreme environments?*

The C-OPS backplane has been used successfully in waters with very low salinity and temperatures (e.g., the Arctic Mackenzie River estuary), as well as very high salinity and temperatures (e.g., the Great Salt Lake) with no discernible degradation in data quality. For the latter, a large amount of weight was added along the bottom of the backplane to counter the extra buoyancy of the hypersaline water mass (Fig. B10).







**Fig. B10.** A closeup of a portion of the C-OPS backplane as configured for sampling in the Great Salt Lake aboard R/V *Recon 18* showing the large amount of weight used: one large weight plus several smaller weights on the left and two large weights on the right.

The requirement for negative (positive) buoyancy in hypersaline (fresh) water masses need not be accomplished solely by adding (removing) weight; it is equally effective to remove (add) flotation. This duality allows for a fine tuning of buoyancy, because of the different sizes provided in the weight and flotation discs. If the addition or removal of buoyancy unbalances the roll of the profiler, either flotation or weight discs can be moved along the roll axis (Fig. 22) to restore a balanced orientation during descent.

**FAQ 17.** *What are sensible rules to follow for standard and nonstandard cable configurations?*

 *Nonstandard C-OPS and BioSCAN cabling configurations could have deleterious unintended consequences, so caution is warranted whenever new cabling scenarios are contemplated.*

This overarching cautionary statement is true for all nonstandard uses of Y-cables and especially true if the BioSHADE instrument is involved (Exercise 6.3.2). The latter extra caution is warranted, because the voltage regulator in the BioSHADE that supplies the outputs for the other instruments (i.e., the BioGPS and solar reference) must handle the excess voltage drop from the elevated BioSHADE input voltage to the desired lower voltage for all other aggregator types. The inclusion of any additional load will result in additional power dissipation (heat) and likely either damage the output regulator or force it into thermal shutdown.

 *The use of a Y-cable at the deck box is ill-advised—even without a BioSHADE—if the cable runs for each branch have dramatically different lengths or loads.*

For example, a 5 m run to a single irradiance instrument, and a 300 m run to three underwater instruments is an unbalanced load. The deck box power adjustment routine works by finding the lowest reported aggregator voltage and setting its voltage. For the in-water above example, it is conceivable that the instrument at the end of the 5 m run will either be exposed to excess voltage or at least have its voltage regulators stressed as they attempt to dissipate the undesired voltage overhead.

Consequently, sensible rules for all cable configurations are as follows:

1. The cable run for the C-OPS profiler should be limited to 350 m and can support two or three instruments.

 *The BioSHADE cannot be connected to this cable run.*

2. The cable run for the BioSCAN is limited to 350 m and can support two or three instruments.

 *The BioSHADE cannot be connected to this cable run.*

3. The cable run for the solar reference is limited to 125 m and can support the BioSHADE, BioGPS, and an irradiance instrument.

4. A Y-cable is only to be used at the instrument end of a cable run, and each branch of the Y-cable should be less than 5 m in length.

5. If required to overcome an unanticipated cable failure, up to five instruments can be operated from a single deck box port with a cable run of up to 200 m by using multiple Y-cables at the instrument end of the cable run, taking care to observe rule 4 above.

6. If necessary to overcome an unanticipated cable failure, the output of a deck box port may be connected to a Y-cable with branch runs of greater than 5 m only if the relative loads and cable lengths of each branch are balanced.

 *No branch of the cable run should exceed 200 m, no more than five instruments total can be connected, and the BioSHADE cannot be connected to this cable run.*

Considering rule 6 in more detail, a single deck box port could be connected to a Y-cable with a short adapter cable, and then a 100 m sea cable with two instruments could be run from one branch of the Y, and a 100 m deployment cable with a BioGPS and an irradiance instrument could be run on the other branch (100 m times two instruments on each branch is a balanced load). Alternatively, a 50 m sea cable with two instruments could be run from one branch of the Y, and a 100 m deployment cable with a single irradiance instrument could be run on the other branch (50 m times two instruments equals 100 m times 1 instrument, and is a balanced load).

 *Load and cable length products that are not balanced to within 10% must be avoided.*

For example, a 200 m sea cable run with two instruments on one branch, and a 5 m interface cable with a single irradiance instrument on the other branch is not balanced and must be avoided (200 m times 2 instruments is greater than 5 m times 1 instrument, and is not balanced).

**FAQ 18.** What are the advantages of C-PrOPS for deep- and shallow-water sampling?

The recently commissioned C-PrOPS accessory (Fig. A2) allows a C-OPS with state-of-the-art microradiometer instruments to be steered from the deployment platform (e.g., an anchored boat or shoreline) with two small digital thrusters, thereby minimizing mixing. In deep waters, the thrusters allow the C-OPS to be moved away from the large ship without the need for time consuming ship maneuvers or the negative consequences of propeller or thruster turbulence (Fig. A5). In shallow waters, the thrusters provide the same advantages (Fig. 24) plus the ability to position the profiler close to the shore without significantly stirring up bottom sediment (Fig. B11).

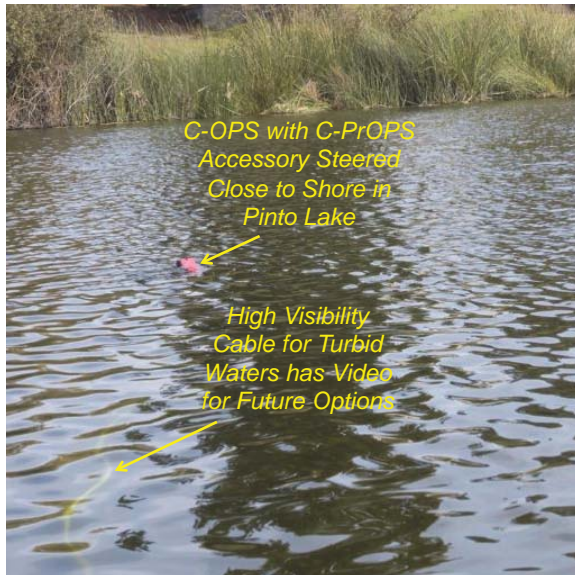

**Fig. B11.** The steering of C-OPS close to the shore in Pinto Lake (Watsonville, California) using the C-PrOPS accessory from the anchored R/V *Recon 18*. The high-visibility cable has a video capability for future imaging options.

A comparison of C-OPS with and without the C-PrOPS accessory in the shallow waters of Elkhorn Slough (Monterey, California) verified the improved ability to collect high-quality data using C-PrOPS in shallow waters. A direct and tangible expression of the improvement is how long it took to collect the replicate casts at each station and whether or not the extrapolation interval used to derive the water-leaving radiance had to be substantively changed from one cast to the next at a particular station. Before C-PrOPS, it took about 17.6 min (on average) to collect 3–4 replicate casts, whereas with C-PrOPS, 5 replicate casts were obtained in 8.8 min (on average)—a factor of 2 improvement. Equally importantly, either no or minor adjustments to the extrapolation intervals for each station of replicates were needed, because C-PrOPS minimized the influence of heterogeneity on the sampling across all wavelengths.

**FAQ 19.** Is there a mechanical system to keep a reference level if the platform (or pipe mast) does not maintain (or start with) a level trim?

There are a number of approaches to adjusting the level of a surface reference, including the use of wedges, rubber shims, hose clamps, and guy wires (Sect. 12.4). Another common approach uses three threaded rods to orient two surfaces relative to one another. In regards to the latter, the Biospherical Field Leveling Accessory with Adjustable Trim (BioFLAAT), shown in Fig. B12, allows a mast to be installed *close* to plumb and then have the reference system leveled or a system that was originally plumbed to be adjusted to being level.



**Fig. B12.** The prototype BioFLAAT device built from two 1½ in 316SS pipe flanges. Black passivated components were used for simplicity and to improve clarity (courtesy J. Morrow).

In the BioFLAAT design, the three threaded rods are actually 316 SS bolts. The bolts are fitted through two pipe flanges and act as *legs* to establish the reference plane for leveling. The device uses 12 self-leveling flange nuts with cupped washers (also known as spherical collar nuts) to accommodate angle adjustments easily made using commonly available tools (e.g., a small- or medium-sized adjustable wrench). The convex nut swivels against the concave surface of the washer to align with the threaded bolts at angles of up to  $\pm 4^\circ$  without distortion. The use of only three legs mechanically constrains the design, so it does not wobble when the nuts are tightened, and makes adjustment less time consuming.

Differing pipe sizes are accommodated using reducers (e.g., 1½ to 1 in NPT in Fig. B12). The flanges in Fig. B12 are also drilled with four holes, so they can be mounted on a field tripod for deployments wherein the reference is to be used on a platform that is not moving (e.g., on land or an offshore structure).

**FAQ 20.** *What does changing a locking sleeve look like graphically?*

Changing a locking sleeve (Sect. 2.5) is presented graphically in Fig. B13. A miniature flat-bladed screwdriver or metal pick is needed to facilitate working with the steel ring part of the locking sleeve (Fig. 4). The steel ring prevents the locking sleeve from sliding past the connector, but only if it is securely positioned in the retaining groove at the end of the locking sleeve shell. The steel ring is a helix “spring” with three layers (similar to a ring used to hold keys), as shown in Fig. B13a.

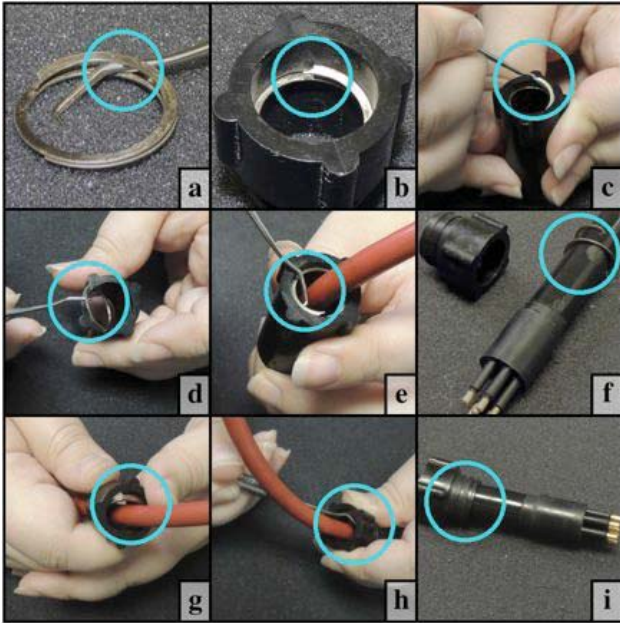

**Fig. B13.** Changing a locking sleeve in nine graphical steps with the focus of each step shown in a cyan circle: **a)** a metal pick reveals the split layers of the steel ring; **b)** each end of the ring has an indent; **c)** working a metal pick into the indent allows the ring to be released from the retaining groove; **d)** the ring completely released from the retaining groove; **e)** initially releasing the ring from a locking sleeve on a cable; **f)** the female locking sleeve removed from the connector with the new male lacking sleeve ready to be pushed over the connector body; **g)** the steel ring pushed into the back of the male locking sleeve at an angle; **h)** the steel ring fitted into the retaining groove; and **i)** the replacement male locking sleeve ready for use (courtesy J. Morrow).

A steel ring retained inside a groove within the end of a locking sleeve shell is shown in Fig. B13b, wherein the ring is not entirely seated in the retaining groove of a male ridge (MR) locking sleeve to emphasize that the ring can be pried out of the ring at one end and it will remain accessible for additional work. Figure B13b also emphasizes that the end of the ring has a small indent to allow a tool (miniature screw driver or metal pick) to catch the end of the ring and pull it out of the groove.

Once the ring is initially pulled out of the retaining groove, it can be incrementally pried from the rest of the groove by working from the starting edge to the other end. Figure B13c shows this being done for a female groove (FG) locking sleeve.

Once the entire ring has been worked out of the retaining groove, the ring is usually still captured in the locking sleeve shell (Fig. B13d), because it is larger than the inner diameter of the shell. The ring can be worked out of the shell with the tool being used or grasping it by hand (or with a pair of needle-nose pliers) and pulling it out.

When replacing a locking sleeve on a cable, the presence of the cable complicates the task somewhat, but it remains straightforward if small tools are used. Again, the process begins by working one end of the ring out of the retaining groove for the steel ring, as shown in Fig. B13e for a female locking sleeve. Note that a female locking sleeve is easier to work with, because the retaining groove is closer to the end of the locking sleeve shell than for a male locking sleeve (Fig. B13b).

Once the steel ring is released from the retaining groove, the original locking sleeve shell can be slid over the molded connector and replaced with a new locking sleeve. In Fig. B13f, the new male locking sleeve is shown next to the connector with the steel ring still coiled around the connector body. Note that the steel ring is “sprung” outward and is no longer collapsed as in Fig. B13a, but this is not a source of impediment for any future steps.

A reliable way to insert the split ring into the replacement locking sleeve is to push the steel ring into the back of the locking sleeve shell at an angle by hand (Fig. B13g). Because the inner diameter of the shell is less than the steel ring, the steel ring will tend to mostly collapse from its sprung state during this process.

Starting on one edge of the steel ring, the remaining part of the ring is then rotated into the retaining groove until an audible “click” is heard. In some cases, it is helpful to push the ring into place incrementally around the circumference of the ring. The pry tool can then be used to confirm all of the split ring is fitted into the retaining groove (Fig. B13h). This is done by going around the circumference of the steel ring and pushing the ring into the groove to make sure no sprung part of the ring is sticking out of the retaining groove.

 *It is critical to confirm the entire steel ring is correctly fitted into the retaining groove, because this prevents the locking sleeve from sliding past the connector and unintentionally allowing the connector to be disconnected if either cable is pulled on.*

Once a proper fitting of the steel ring inside the retaining groove has been confirmed, the replacement locking sleeve is now ready for use (Fig. B13i).

 *When the new locking sleeve is mated, it is advisable to confirm it holds securely against the connector body by pushing and pulling on the locking sleeve assembly.*



## APPENDIX C

NAUTICAL TERMS (<http://en.wikipedia.org/>)

- 01 Level The first deck that is *above* the main deck (pronounced “oh-one level”); although called a deck, it is referred to as a level, because it is usually an incomplete deck that does not span from bow to stern and from side to side.
- 02 Level The deck *above* the 01 level (pronounced “oh-two level”).
- 03 Level The deck *above* the 02 level (pronounced “oh-three level”).
- Abaft In, on, or toward the stern, usually relative to some part of the ship (“abaft the stack”).
- Adrift Afloat and unattached in any way to the shore or seabed, and not under way.
- Afore In, on, or toward the bow, usually relative to some object (“afore the bridge”).
- Afterdeck The deck behind (to the stern of) the bridge.
- Aground Resting on or touching the seabed (usually involuntarily).
- Amidships In the middle of a ship, in terms of its length.
- Anchor A metal, hook-like or plough-like object attached to the ship by a line or chain and designed to grip the seabed to prevent or slow the drift of a ship, or to deploy an anchor (“the ship anchored offshore”).
- Aport To port, as in, “turn hard aport” (to avoid an obstacle).
- Astarboard To starboard, as in, “turn astarboard” (to avoid a head-on collision).
- Athwartship Being across the ship from side to side.
- Beam The width of a ship at the widest point as measured at the nominal waterline.
- Bight A loop in a line.
- Bilge The bottom of a ship just over and around the keel (being the lowest part of the ship, water and other fluids collect here and must be pumped out).
- Bosun The (petty) officer who controls the work of other seamen (also boatswain).
- Bow The front end of the ship, i.e., the end in the direction of forward motion.
- Bowsprit A spar projecting from the bow that is used as an anchor for rigging.
- Bridge The space from which the ship is controlled.
- Bridge Wing A deck on the side of the bridge.
- Bulbous Bow A rounded protrusion at the bow just below the waterline that modifies the flow of water around the hull to reduce drag and increase speed, range, fuel efficiency, and stability.
- Bulkhead A watertight vertical panel, except for the hull itself, which increases the structural rigidity of the vessel, divides areas into spaces, creates watertight compartments that can contain water in the event of flooding, and creates firebreaks to contain fires.
- Bulwark The extension of the ship’s side along the gunwale of the main weather deck.
- Bumpkin A spar, similar to a bowsprit, but projecting from the stern and used as an anchor for rigging.
- Captain The person in command of a ship (also called the master).
- Chafe To cause wear on a line by repetitive rubbing against another surface.
- Clear Having freedom of motion without opportunity for interference by collision or entanglement.
- Cleat A T-shaped (usually metal) fixture used to secure a line aboard a vessel or dock.
- Compartment A room (or “space”) formed by decks and bulkheads to contain everything needed to operate the ship (generally speaking, compartments are not called rooms, however, some compartments are called rooms, e.g., state-room, fan room, engine room, etc.).
- Complete Deck A deck that extends from bow to stern and athwartship.
- Crow’s Nest The highest platform on the main mast that will support a person.
- Deck A horizontal structure dividing a ship into separate levels (analogous to a floor in a building), which also strengthens the hull and protects internal spaces. When using “deck,” to mean the floor, it means just the upper surface of the deck, not the entire structure of the deck. “Deck” may also refer to an entire level, such as, “the radio room is on the second deck.”
- Draft The vertical distance from the bottom of the keel to the waterline on the hull.
- Dog A lever or clamp around all edges of a hatch, which when tightened, makes the hatch watertight.
- Door A usually swinging barrier by which an entry is opened (closed) to access (seal) a space. The door may be freestanding or incorporated with a hatch; the hatch is normally kept open and only closed when necessary.
- Fair Lead A straight unobstructed course of a line between two points.
- Fairlead A ring, hook, or other device used to keep a line or chain running in the correct direction or to prevent it rubbing or fouling.
- Fairway A navigable part of a river, bay, or harbor.
- Fall Off The opposite of pointing up or heading up wherein the heading of the ship is changed in a direction that is more down wind, which brings the bow leeward (also bear away, bear off, or head down).
- Fantail The stern area of the main deck for a ship without a poop deck (also called the main deck aft).
- Fast Fastened or held firmly (e.g., “fast aground” means stuck on the seabed and “made fast” means tied securely).
- Fathom A unit of length used especially for measuring the depth of water wherein 2yd (6ft) equals 1ftm (exactly 1.8288m). When burying the dead, it is customary to inter the corpse at a depth of 1ftm, or *six feet under*. For a burial at sea, wherein the corpse must be weighted to remain at depth under the column of water, a minimum of six fathoms of water is required,

## Mobilization Protocols for HySEAS Observations

- which established the origin of the phrase “to deep six” something, as in to discard or dispose of something.
- First Mate** The officer who is second in command to the captain on a commercial ship and also called the executive officer or XO (pronounced “ex-oh”).
- Following Sea** A sea where waves are directly in the same motion of the ship (which increases the speed and produces a smoother ride).
- Forecastle** The deck above the main deck and located at the bow, where anchor machinery is positioned (pronounced “fohk’sel”).
- Foul** Having freedom of motion interfered with by collision or entanglement, and, thus, the opposite of clear (a line is foul when it does not run straight or smoothly, and an anchor is foul when it is caught on an obstruction).
- Freeboard** The distance from the waterline to the upper edge of the hull.
- Funnel** A smokestack (or stack) on the superstructure to expel steam, smoke, or exhaust (especially from an engine).
- Gangplank** A movable bridge used in boarding or leaving a ship at a pier (also known as a “brow”).
- Gangway** An opening in the bulwark of the ship to allow passengers and crew to board or leave the ship.
- Gunwale** The top edge of the hull (pronounced “gunnel” to rhyme with “tunnel”).
- Guy** A line (chain, rod, or wire) attached to something as a brace or guide (also guyline).
- Hatch** A horizontal or vertical door through a water tight deck or bulkhead containing dogs (levers) around all edges, so it may be tightened to make it watertight.
- Hawse** A shaft or hole in the side of a ship (usually at the bow and stern) through which a hawser (or an anchor chain) passes (also called a hawsehole or hawsepipe).
- Hawser** Large diameter line used for mooring or towing a ship.
- Hawsehole** A hawse (or hawsepipe).
- Hawsepipe** A hawse (or hawsehole).
- Head Sea** A sea where waves are directly opposing the motion of the ship (which slows the speed and produces a rougher ride).
- Heave** The transient up-and-down (vertical) motion of a ship, or to haul or pull on a line.
- Heaving To** Turning into the seas (i.e., the direction the wind waves are coming from) and applying only enough power to maintain position (used to protect the ship in heavy seas).
- Heel** The angle of a tilt caused by the force of the wind on a ship.
- Hold** A large open compartment below the weather deck used mostly for storage or cargo or items needed for ship operation.
- Hove To** In a stationary position and headed into the wind.
- Hull** The main outer body of a ship with interior strengthening members designed to prevent structural collapse, plus decks, bulkheads, and partitions that form individual compartments.
- Icing** A serious hazard wherein cold temperatures (below about  $-10^{\circ}\text{C}$ ) plus high wind (typically force 8 or above on the Beaufort scale) result in spray blown off the sea freezing immediately on contact with the ship.
- Jacob’s Ladder** A rope ladder having wooden rungs that is used to board (or disembark) a ship up (down) the side.
- Keel** The central structural basis of the hull, to which all other members used in constructing the hull are attached either directly or indirectly.
- Knot** A unit of speed equal to 1 nmi (1.8520 km or 1.1508 mi) per hour (originally speed was measured by paying out a line from the stern of a moving boat; the line had a knot every 47 ft 3 in (14.40 m), and the number of knots passed out in 30 s gave the speed through the water in nautical miles per hour).
- Ladder** Stairs, which may also be actual vertical ladders, that lead between decks.
- Ladder Well** The space containing a ladder that leads from one deck to another.
- Lay** To come and go, used in giving orders to the crew (e.g., “lay forward”), to direct the course of the ship (e.g., “lay to starboard”), and to twist the strands of a rope together.
- Lead** The course of a line from end to end (pronounced “leed”).
- Lee Side** The side of a ship sheltered from the wind.
- Level** A general term used to designate decks above the main deck (the first level above the main deck is the 01 level, the second level is the 02 level, etc.).
- Line** Any of the majority of cordage (“ropes”) used on a ship (the specificity of intended use is part of the specific name of a line, such as *mizzen topsail halyard*).
- List** The angle of a stable tilt caused by improperly loaded or shifted cargo or ballast (can also be caused by flooding).
- Main Deck** The uppermost complete deck (except on an aircraft carrier, wherein the hangar deck is the main deck).
- Mainmast** The tallest mast on a ship (also called the main).
- Mast** A vertical spar that extends above the superstructure to support a yardarm used for hoisting flags and supporting a variety of equipment (e.g., antennas, radar, lights, etc.).
- Master** The person in command of a ship (also called the captain).
- Mate** One a large ship, any one of a number of officers, but on a small ship, the first mate.
- Memory** A tendency of cable (or tape) to attempt to return to the original shape (length) after being uncoiled (elongated).
- Nautical Mile** A unit of length (denoted here as nmi) used in navigation that is about one minute of arc of latitude along any meridian or one minute of arc of longitude at the equator, and set by international agreement at exactly 1,852 m (6,076.12 ft.).

|              |   |                |  |
|--------------|---|----------------|--|
| Overhead     | The underside of a deck, i.e., the “ceiling” of a space.  |                |  |
| Partial Deck | Any deck that is not a complete deck.   |                |  |
| Passageway   | A hallway that connects compartments.   |                |  |
| Pitch        | The fore-aft motion of a ship from a rotation about the beam (transverse) axis, thereby causing the bow and stern to rise and fall.   | Stack          | A funnel (or smokestack).  |
| Poop Deck    | A partial deck above the main deck located all the way aft.   | Standoff       | A fixture used for holding something at a distance from a surface.   |
| Port         | The left side of a ship, when facing the bow (denoted with a red light at night).   | Starboard      | The right side of a ship, when facing the bow (denoted with a green light at night).   |
| Porthole     | A small window through the hull of a ship to provide light and viewing, for which the glass section may swing open to provide air, usually consisting of a circular glass disk encased in a metal frame that is attached into the side of the hull. A porthole has a metal cover that may be closed and dogged to secure it for heavy seas, prevent light from escaping, and to provide protection. | Stateroom      | A private compartment (or cabin) with sleeping accommodations on a ship.   |
| Propeller    | The screw at the end of the shaft that turns to propel the ship.  | Stern          | The rear end of the ship, i.e., the end in the opposite direction of forward motion.   |
| Quarterdeck  | Not an actual deck, but an area designated by the commanding officer for the conduct of official functions, and it serves as the station of the officer of the deck (its location in port depends on how the ship is moored).   | Stow           | To store, or to put away (e.g., personal effects, equipment, or cargo).  |
| Roll         | The side-to-side motion of a ship from a rotation about the fore-aft axis, causing the port and starboard sides to rise and fall.   | Superstructure | The structure that rises above the main deck of a ship.  |
| Rudder       | A vertical device near the stern of a ship used to steer the ship as it moves through the water by redirecting the water moving past the hull to impart a turning or yawing motion to the ship.   | Tack           | A zig-zag course change wherein the heading is into and through the wind so as to sail directly towards the wind.  |
| Scuppers     | Drains and ports, frequently installed in a continuous trough, along the bulwarks that allow water to flow out and over the side of the ship during heavy weather.  | Third Deck     | The first complete deck <i>below</i> the second deck.  |
| Sea Anchor   | A stabilizer, in the form of a large bag or drogue made of heavy canvas, deployed in the water for heaving to in heavy weather (it acts as a brake and keeps the hull in line with the wind and perpendicular to waves).  | Transom        | A more or less flat surface across the stern of a ship.  |
| Second Deck  | The first complete deck <i>below</i> the main deck.   | Under Way      | A vessel that is moving under control (neither at anchor, made fast to the shore, aground, nor adrift).  |
| Shackle      | A usually u-shaped fastening device secured by a bolt or pin through holes in the end of the two arms; or a unit of measure for the lengths of nautical cables and chains, especially anchor chain, having a standardized value of 15 ftm (27.432 m).   | Void           | An empty space that is not used for anything and is sealed.  |
| Shipshape    | In good order (or squared away); trim and neat.   | Wake           | The turbulence behind a vessel (not to be confused with wash).   |
| Slack        | The part of a line not held taut; the loose or unused part.   | Walkway        | A demarcated area (sometimes as a platform) with stanchions and chains that extend around the perimeter of a hazardous area to permit safe passage.            |
| Smokestack   | A funnel (or stack).  | Wash           | The waves created by a vessel (not to be confused with wake).  |
| Space        | A compartment, or a section of a compartment, can also be referred to as a space.   | Waterline      | The line on the hull of a ship to which the surface of the water rises (the portion of the ship above the line is afloat, and the portion below is submerged). |
| Sponson      | A projection from the side of a ship for protection, stability, or the mounting of equipment.   | Way            | Speed, progress, or momentum (to make way is to move and to lose way is to slow down).   |
| Squared Away | To figuratively have everything in order and readiness, or shipshape (derived from the practice of having yards held rigidly perpendicular  | Weather Deck   | A deck or part of a deck that is exposed to the weather.   |
|              |   | Weather Side   | The side of a ship exposed to the wind.  |
|              |   | Wheel          | The steering device on a ship; usually a wheel with a horizontal axis, connected by cables to the rudder (also called the ship’s wheel).                       |
|              |   | Wheelhouse     | The location where the wheel is located (also called pilothouse or bridge).  |
|              |   | Whitecaps      | Foam or spray on wave tops caused by stronger winds (usually above Force 4).   |
|              |   | Windlass       | A winch mechanism, usually with a horizontal axis.   |
|              |   | Windward       | In the direction that the wind is coming from.   |
|              |   | Yard           | A horizontal spar (also a dockyard or shipyard).   |
|              |   | Yardarm        | The very end of a yard (often mistaken for a “yard,” which refers to the entire spar).   |
|              |   | Yaw            | A ship’s rotational motion about the vertical axis, causing the fore and aft ends to swing from side to side.  |



APPENDIX D  
 RADIOTELEPHONE TERMS  
 (<http://en.wikipedia.org/>)

- 5×5 Five By five.
- Acknowledge I understand the contents of the received message.
- Affirmative Yes, confirm, permission granted, or correct. With a poor quality connection, the words “Affirmative” and “Negative” can be mistaken for one another, so “Yes” and “Confirm” are also used. Sometimes a *double click* sent over the radio by keying the mic twice to produce an audible “-” sequence (like Morse code) is used when the addressee is unable to talk due to heavy workload or stress.
- Break Signals a requested pause to open the channel for other transmissions, especially for allowing higher priority traffic to get through.
- Break-Break Signals to all listeners on the frequency, the message to follow is priority.
- Call Sign The combination of characters or words assigned to an operator for use in communication.
- Come In Permission given to begin speaking.
- Confirm Affirmative.
- Copy Transmission heard; okay or all right.
- Disregard Cancel transmission in progress or last transmission.
- Do You Read? How do you hear my transmission (e.g., loud and clear)?
- Five By Five Loud and Clear†.
- Go Send your message; also Go Ahead or Send Your Traffic.
- I Spell I will spell the following phonetically (e.g., “GMT, I spell, Golf Mike Tango.”).
- Loud And Clear I understand; also, Five By Five.
- Mayday A distress call, which is repeated three times at the beginning of every following transmission relating to the current distress situation (has priority over urgency and safety calls).
- Negative With a poor quality connection, the words “Affirmative” and “Negative” can be mistaken for one another, so “No” is also used.
- No Negative.
- Out Transmission ended and no answer is required or expected.
- Over Transmission ended and a response is both required and expected, so go ahead and transmit (short for “Over To You”). “Over” and “Out” are never used at the same time, because their meanings are mutually exclusive. Historically, “Over and Out” was used to mean “Over to you, and when you are done, I am out.” The same meaning can be communicated with just “Out,” as in “Lab, Deck; station in Two minutes; Out.”
- Pan-Pan An urgency call, which is repeated three times at the beginning of every following transmission relating to the urgent situation (has priority over safety calls).
- Radio Check How do you Read me, i.e., what is my signal strength and clarity (Table 1)?
- Read Hear, as in “I Read you Loud and Clear.”
- Read Back Repeat last transmission.
- Read You I hear you, with signal strength by clarity (as in “I read you five by five”).
- Repeat An artillery proword not be used as an R/T proword, although it can be used in the middle of an R/T transmission to emphasize information, as in, “Lab, Deck, the profiler is under the boat; Repeat, the profiler is under the boat; Over.”
- Roger Transmission received (even without understanding it), also “Roger That”; a “Roger” response to a “Radio Check” means “Loud and Clear” (Roger was the U.S. military designation for the letter “R,” as in received, from 1927 to 1957). It is important to not say “Roger” when actually meaning “Affirmative” or “Negative.”
- Roger That Roger.
- Say Again Please repeat last transmission (the word “repeat” should not be used, because it is associated with artillery requests).
- Sécurité A safety call, which is repeated three times at the beginning of every following transmission relating to the safety situation (has priority over routine calls).
- Send Initial call received; send me your message.
- Speak Slower You are talking too fast.
- Standby Pause for a few seconds (also, Wait One), otherwise “I Will Call You Back” must be used.
- This Is Identifies the addresser (the person speaking).
- Voice Procedure The variety of techniques used to clarify, simplify, and standardize spoken communications over two-way radios.
- Wait The answer or requested information is not immediately available, but will be available shortly; until then, no transmission will be sent, so do not expect a reply (can be suffixed with a number to indicated estimated number of minutes until a reply can be expected, e.g., “Wait Two” indicates a reply in approximately two minutes).
- Wait One Standby for a short time (approximately one minute or less).
- Wilco I understand the received message and will comply with the contents (thus, “Roger” and “Wilco” used together is redundant, because “Wilco” includes the acknowledgement function of “Roger,” so “Roger Wilco” should not be used).
- Yes Affirmative.

† In voice procedure, a transmitting station may request a report on the quality and strength of their signal, which is reported by the receiving station on two scales wherein the first is for signal strength (loudness) and the second for signal clarity (Table 1). Both scales range from one to five, with one as the worst and five as the best. The receiving station reports these numbers separated with the word “by,” so “five by five” means a signal that has excellent strength and perfect clarity (the most understandable signal possible).

APPENDIX E  
DESCRIPTION OF TOOLS AND PARTS



An **adjustable wrench** has one fixed jaw and one movable jaw wherein turning a knurled gear sets the variable width of opening at one end of the handle and the maximum opening is sized to match the specific dimensions of a common range of fasteners, e.g., nuts and bolts.



A **ball-point driver** is a specific kind of hex (or Allen) key or wrench wherein on one end the hexagonal cross-section used to drive bolts and screws that have a hexagonal socket in the head is on a tip that is ball shaped. The ball-shaped end permits angled entry of the driver of up to 25° to engage and drive the bolt or screw thereby allowing the fastener to be tightened or loosened in space-limited situations.

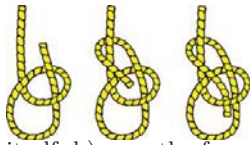

A **bowline** (rhymes with “toe pin”) is a knot used to form a secure loop in a line that will not jam while remaining easy to untie as follows: a) form a loop in a line by passing the free end over itself; b) pass the free end under and through the loop to take a turn behind the standing line before the loop; c) pass the free end of the line over and through the loop; and d) tighten the knot by pulling on the free end while holding the standing line.



A (usually nylon) **cable tie** binds several electronic cables or wires together to secure or organize them (also called a tie-wrap, zip tie, or Ty-Rap per the Thomas & Betts brand name). The cable tie is put around the item(s) to be bound, with the loose tape end pulled through the space in the head. When the loose end with integrated rack is pulled past the head ratchet, it is prevented from being pulled back and the resulting loop may only be pulled tighter.



A **cable tie gun** is a tensioning device or tool used to apply a cable tie with a specific tension. The tool may cut off the tape flush with the head to avoid a sharp edge which might cause injury (e.g., the Paladin model 1828.1).



A **chinese finger** is a woven lacing secured over a cable with crossings or webbing that increase in distance from one another away from the cinch point. The cinch point usually has a loop with a shackle, and when tension is applied to the shackle, the lacings tighten on the cable, becoming tighter as tension is increased.



A **cleat** is a T-shaped (usually metal) fixture with two horns above a protruding base wherein the horns extend parallel to a flat surface, especially on a boat or dock. A cleat resembles an anvil and is used for securing a line and usually used to hold something fast (e.g., a boat to a dock).



A **cleat hitch** is a knot used to hold something fast to a cleat (e.g., a boat to a dock) as follows: a) a line is turned around the base of the far side of the cleat making a full round turn that is looped under the opposite horn and over the top of the cleat; b) a figure eight is made by passing the line around and under the opposing horn with the free coming over the top of the cleat; and c) a half hitch is mated parallel to the first hitch, wherein the line is passed around and under the opposite horn with the free end pulled tight *under* the line forming the figure eight.



A **diagonal cutter** is a pliers with beveled cutting jaws at an angle to the handles to permit cutting off wires close to terminals. Because the jaws are sharpened, they can be used for cutting a wide variety of materials.



A (worm gear) **hose clamp** consist of a stainless steel band with a screw thread pattern and a captive screw at one end that is turned with a screwdriver or nut driver to tighten or loosen the band.



The Bosch PS40 cordless **impact driver** has a voltage rating of 10.8DCV (12VDC maximum), a no-load speed of 0–1,800 min<sup>-1</sup> with an impact rate of 0–3,000 min<sup>-1</sup>, a maximum torque of 800 in lb, and a 1/4 in hex-shank chuck with locking sleeve.



A **needle-nose pliers** has long slender jaws used for grasping small or thin objects, which when held perpendicular to the jaws, can be bent or turned. Cutting blades are usually formed at the vertex of the jaws, which can be used for cutting (e.g., the free end of a cable tie).



A **nut driver** is a tool for tightening hexagonal nuts and bolt heads, wherein a socket is attached to a shaft with cylindrical handle (similar in appearance to a screw driver). The shaft is usually hollow to accommodate varying lengths of exposed shank onto which a nut is threaded.



An **open end wrench** has jaws with a fixed width of opening at one or both ends of the handle, wherein the fixed width is sized to match the specific dimensions of common fasteners, e.g., nuts and bolts.



A **pipe coupler** is a short piece of pipe that is usually threaded on both ends with female grooves. If the coupler has different sized threads, it is called a reducing coupler or *reducer*.



A **pipe nipple** is a short piece of pipe that is usually threaded on both ends with male ridges. If there is no exposed pipe between the threads (shown left), the nipple is called a *close*.



A **scaffolding clamp**, as presented here, has two clamping surfaces joined at a swivel connection. The clamping surfaces are shaped to securely clamp to a range of pipe sizes, and the swivel permits two pieces of pipe to be secured at arbitrary angles to one another, but usually perpendicular to one another.



A **shackle** is a metal link, typically U-shaped and noncorrosive, closed by a bolt, and used to secure a chain or line to another fixture. The bolt, even if it is captive, is usually secured using wire or a cable tie to prevent loosening.



A **slip-joint pliers** has the joint adjustable to two or more positions so as to obtain a wide to narrow opening for the jaws.



A (worm gear) **smooth band hose clamp** wherein the band is solid and the worm gear cannot penetrate to mar the surface underneath the band. Like a standard hose clamp, the clamp is put around the item(s) to be joined, with the loose end fed into the space between the band and the captive screw. When the screw is turned CW, it acts as a worm drive pulling the threads of the band, causing the band to tighten (or when turned CCW to loosen). Because of their strong holding power, they can be used to affix an instrument to a mount without damaging the painted or anodized surface of the instrument.



**Velcro** is commonly used to mean any type of *hook-and-loop fastener*, but it is a registered trademark by the Velcro company (Amsterdam, Netherlands) for their brand of fasteners. A hook-and-loop fastener consist of two fabric strips attached to opposing surfaces to be fastened. The first component has small hooks and the second has smaller loops. When the two different materials are pressed together, the hooks catch in the loops and the mated surfaces are temporarily bound together. The two components are separated by pulling or peeling them apart, which results in a distinctive “ripping” sound.

## APPENDIX F DEPLOYMENT CHECKLISTS

For first-time or novice practitioners, it is convenient to have deployment checklists for C-OPS and BioSCAN to ensure all important steps are executed for each instrument system. This philosophy is an extension of the effort to list and organize the components needed to mobilize the instrumentation and execute the data acquisition protocols documented here.

To keep the checklists brief, so they are not overly burdensome, a streamlined approach is used wherein it is assumed that certain time consuming activities have been completed or will not occur. For example, it is assumed the solar reference has been properly installed (Sects. 3.1, 4.3, 5.2, and 7.3), b) atmospheric conditions are sufficiently stable that extra procedures to deal with unstable illumination are not required, c) ship maneuvers during data collection have been confirmed, and d) all personnel understand how to start and end an acquisition event.

Other details that might be useful to a particular acquisition event are not always presented in detail, but are mentioned as reminders. For example, the direction of the surface swell and the true wind speed are noted in the BioSCAN checklist, plus recording of the GPS location is mentioned in both checklists. Other types of metadata that should be recorded include overall sky conditions, cloud cover in tenths or octals, and personal observations that impact data quality (e.g., surface debris on the surface of the water).

Also presented for handy reference are diagrams for the following cable assemblies:

1. A six-conductor extension cable for all systems (Fig. F3);
2. A full-duplex (six-conductor) interconnect cable for all systems (Fig. F4);
3. A half-duplex (four-conductor) interconnect cable for all half-duplex systems (Fig. F5);
4. A C-OPS backplane (six-conductor) Y-cable, which is also compatible with the SuBOPS instrument system (Fig. F6); and
5. A BioSCAN Y-cable, which is also compatible with the BioSORS instrument system (Fig. F7).

## ACKNOWLEDGMENTS

The success of the data acquisition and data processing capabilities presented here would not have been possible without support from a variety of NASA programs. The micro-radiometer, aggregator, and resulting instruments were developed as a joint activity between BSI and NASA GSFC under a Small Business Innovation Research (SBIR) program entitled “In Situ Radiometers: Smaller, Faster, and Scalable to Hyperspectral.” The “smaller” refers to the optical instrument that is built with microradiometers being significantly smaller than legacy devices (i.e., more than 25% smaller), the “faster” refers to the sampling rate being significantly faster (i.e., 50–100% or more), and the “scalable to hyperspectral” refers to a significant increase in the number of channels within the same form factor (i.e., a 50–100% increase).

The SBIR Phase I contract NNG05CA40C (2005) resulted in a fully functional microradiometer prototype (not required), which served to illustrate the potential for success of the project. The SBIR Phase II contract NNG06CA03C (20052007) moved the prototype instrument through a complete development cycle, which concluded with the release of a field-tested device. Since then, microradiometers have been used in the following commercial applications: a) the above- and in-water BioSCAN and C-OPS, respectively; b) the ICE-Pro; c) OSPREy above-water and laboratory instruments; and d) the flight certified airborne C-AIR sensor suite.

Much of the perspective presented here was developed as part of the calibration and validation activities of the SeaWiFS, SIMBIOS, MODIS, GEO-CAPE, and ACE projects. The high level of success achieved in the fieldwork for those activities established a foundation of understanding that was the direct consequence of contributions from many individuals who contributed unselfishly to the work involved (e.g., calibration, acquisition, processing, and sampling). The scientists include (alphabetically) D. Antoine, J. Brown, C. Dempsey, K. Hayashi, R. Lind, S. Maritorea, J. Morrow, K. Suzuki, and G. Zibordi; their dedicated contributions are gratefully acknowledged.

The opportunities to establish and refine the mobilization protocols presented here were the result of deployments on a number of exemplary vessels. The officers and crew of these vessels patiently endured a continuing series of requests for assistance and advice when it came time to collect optical data. The professional seamanship and good cheer of the following vessels provided the highest caliber of research opportunities:

- CCGS *Amundsen* (Québec City, Canada), with a particular acknowledgment to the officers and crew of the barge;
- R/V *Gulf Challenger* (Portsmouth, New Hampshire);
- R/V *Hakuho Maru* (Tokyo, Japan);
- USCGC *Healy* (Seattle, Washington), with a particular acknowledgment to the officers and crew of the ASB;
- R/V *John Le Conte* (Tahoe City, California);
- TR/V *Oshoro Maru* (Hakodate, Japan);
- R/V *Pelican* (Cocodrie, Louisiana);
- R/V *Shearwater* (Santa Barbara, California);
- R/V *SRV-X* (Norfolk, Virginia), with a particular acknowledgment to the crew who deployed a small inflatable into the Blackwater National Wildlife Refuge; and
- R/V *Tethys II* (Nice, France).



### ***C-OPS Streamlined Deployment Checklist***

This checklist assumes the following: a) the solar reference was plumbed to minimize shading and reflections from the deployment platform; b) atmospheric conditions are stable; c) communications and ship's procedures for executing a cast have been agreed to with the bridge or ship operator; and d) the initiation and termination of a cast has been established with all personnel.

- 1. Power up the deck box and confirm nominal operation of all devices.
- 2. Ensure all caps are affixed to the optical instrument apertures.
- 3. Collect dark data at all gain stages and tare the pressure transducer.
- 4. Remove the caps (usually three), and stow them in the C-OPS basket.
- 5. After coordinating with the bridge or ship operator to keep the Sun on the deployment side of the ship, lower or *knife* the profiler into the water.
- 6. Using the current and wind acting on the ship, position the profiler away (30–50 m on a large vessel and 10 m on a small boat); if ineffective, use turbulence from the ship's propeller (or a thruster) to position the profiler.
- 7. Verify conditions around the profiler are free of turbulence (e.g., bubbles, and foam) to the greatest extent practicable.
- 8. Execute a shallow cast to verify profiler descent with no pitch or roll biases and average vertical tilts to within 5°. Verify surface loitering and terminal velocity are as desired; if not, adjust flotation and buoyancy and retest.
- 9. Reposition the profiler away from the deployment platform in unperturbed waters (to the extent practicable).
- 10. Verify the deck and computer operators are ready to commence profiling.
- 11. The deck operator issues the *drop-drop-drop* command.
- 12. The computer operator affirms the drop command, starts recording the data, and logs the cast number, plus UTC time and geolocation.
- 13. To finalize the drop initiation, the deck operator slowly hauls the profiler to the surface until the cosine collector is seen, and then releases the cable.
- 14. Once the desired depth is reached, the computer operator tells the deck operator to terminate the cast and haul the profiler back to the surface.
- 15. The deck operator affirms termination and hauls in the profiler.
- 16. After three casts, BioSHADE data are acquired while the profiler is hauled aboard, and subsequently rinse all apertures and profiler with freshwater.
- 17. Blot all optical apertures dry with a lint-free cloth or paper towel, and place the caps on all the optical instruments.

18Sep2013

Fig. F1. An abbreviated checklist for deploying the C-OPS instrumentation.

### ***BioSCAN Streamlined Deployment Checklist***

This checklist assumes the following: a) the solar reference was plumbed to minimize shading and reflections from the deployment platform; b) atmospheric conditions are stable; c) communications and ship's procedures for executing a cast have been agreed to with the bridge or ship operator; and d) the initiation and termination of a cast has been established with all personnel.

- 1. Power up the deck box and confirm nominal operation of all devices.
- 2. Ensure all caps are affixed to the optical instrument apertures.
- 3. Collect dark data at all gain stages and tare the pressure transducer.
- 4. Remove the caps (usually three), and stow them properly.
- 5. Loosen the collet screw so the frame is free to rotate in the azimuthal direction.
- 6. Coordinate with the bridge or ship operator for a stable heading to last approximately 3 min with the Sun positioned amidships, i.e., on the port or starboard side of the ship.
- 7. Point the frame into the swell direction, and report the azimuthal position and direction (towards or away from the frame) to the computer operator.
- 8. Point the BioSCAN frame into the Sun, align the solar compass shadow with the appropriate principal compass marking, and report the azimuthal position to the computer operator.
- 9. Rotate the frame 90° from the Sun so the radiometers are pointed towards the bow, and report the azimuthal position to the computer operator.
- 10. Tighten the collet screw so the frame cannot rotate azimuthally.
- 11. Tell the computer operator to commence data acquisition.
- 12. The computer operator affirms acquisition, starts recording the data, and logs the cast number, plus UTC time, GPS location, and true wind speed.
- 13. To finalize the cast, the computer operator announces when the requisite data (at least 1,024 samples) have been successfully recorded.
- 14. Verify the ship's heading was stable by pointing into the Sun and comparing the azimuthal position is to within  $\pm 2.5^\circ$  of the prior value.
- 15. If needed, coordinate with the bridge for a corrected stable heading.
- 16. After three casts, BioSHADE data are acquired, after which all apertures are rinsed with freshwater.
- 17. Blot the optical apertures dry with a lint-free cloth or paper towel, and place the caps on all the optical instruments.

18Sep2013

Fig. F2. An abbreviated checklist for deploying the BioSCAN instrumentation.

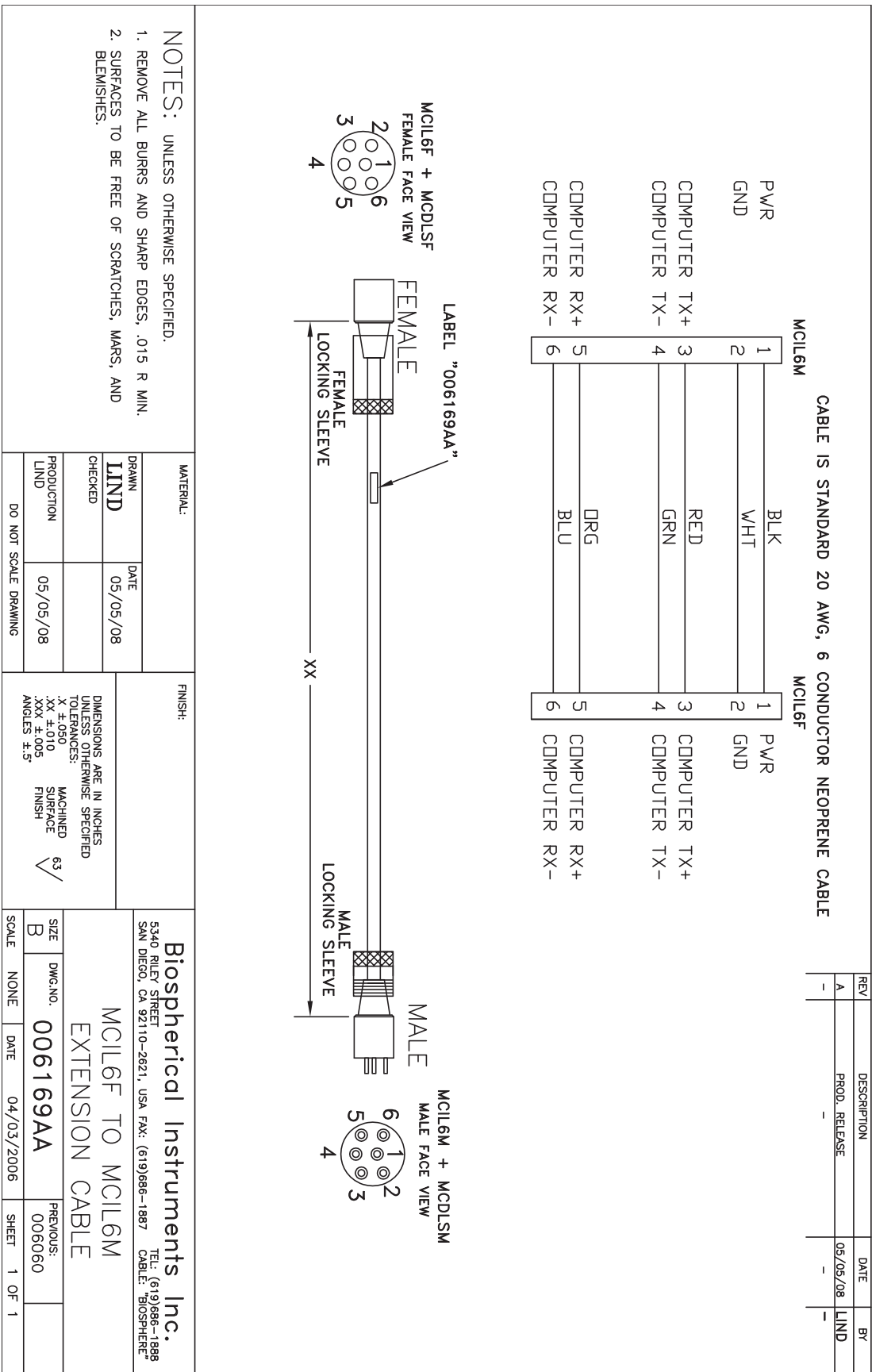

Fig. F3. A HySEAS extension cable.



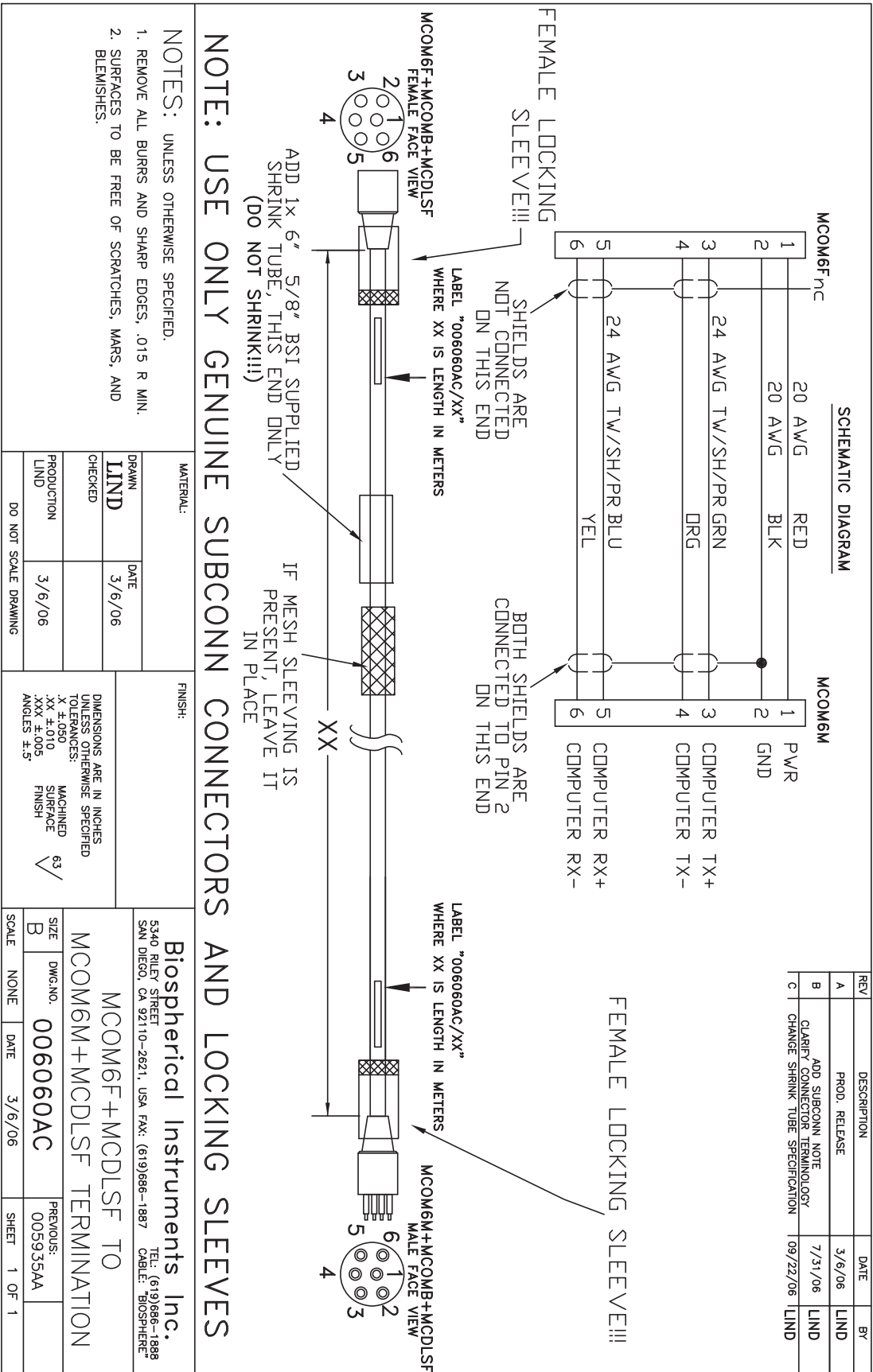

Fig. F4. A HySEAS (full-duplex) interconnect cable.

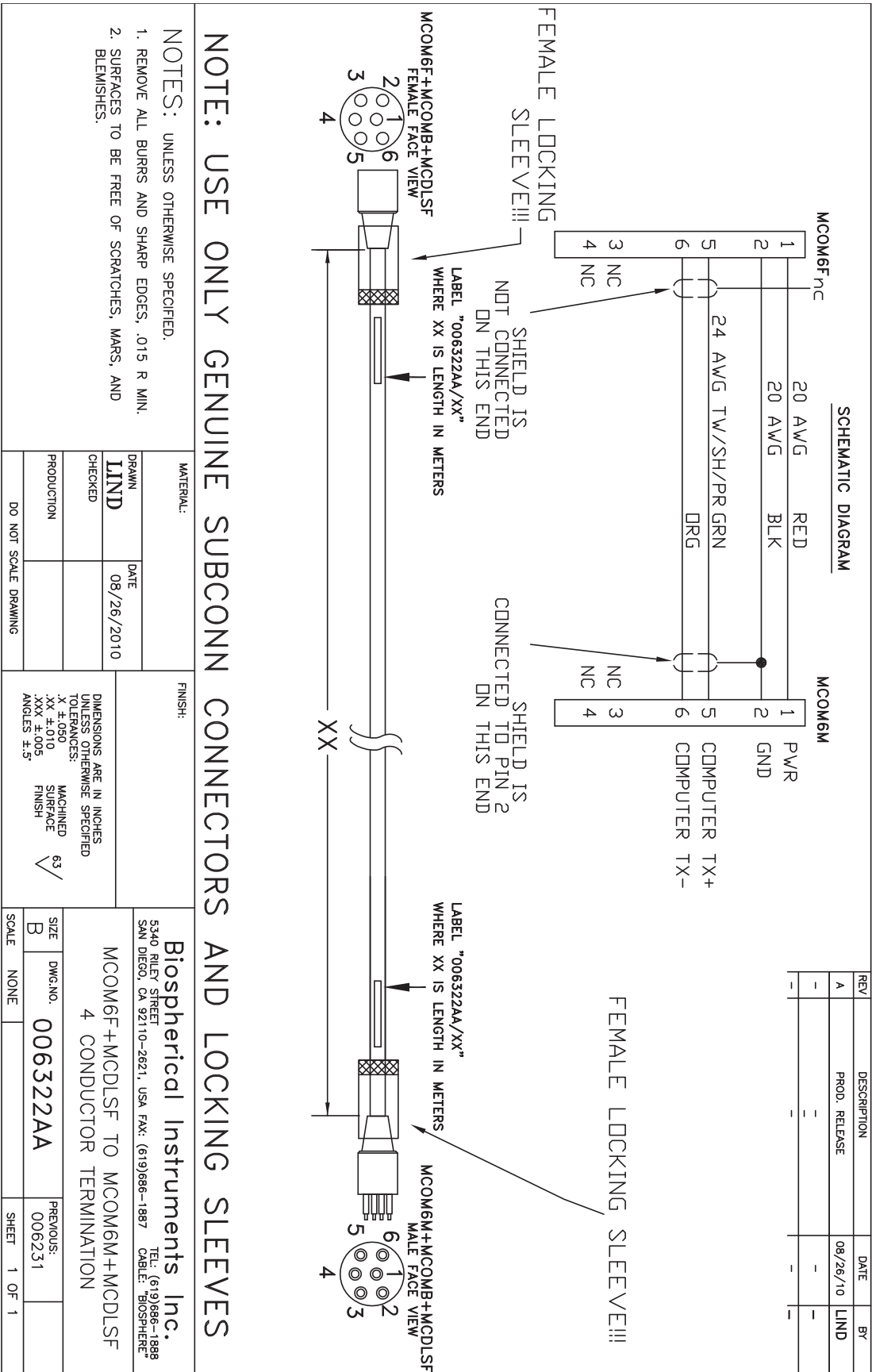

Fig. F5. A HySEAS half-duplex interconnect cable.

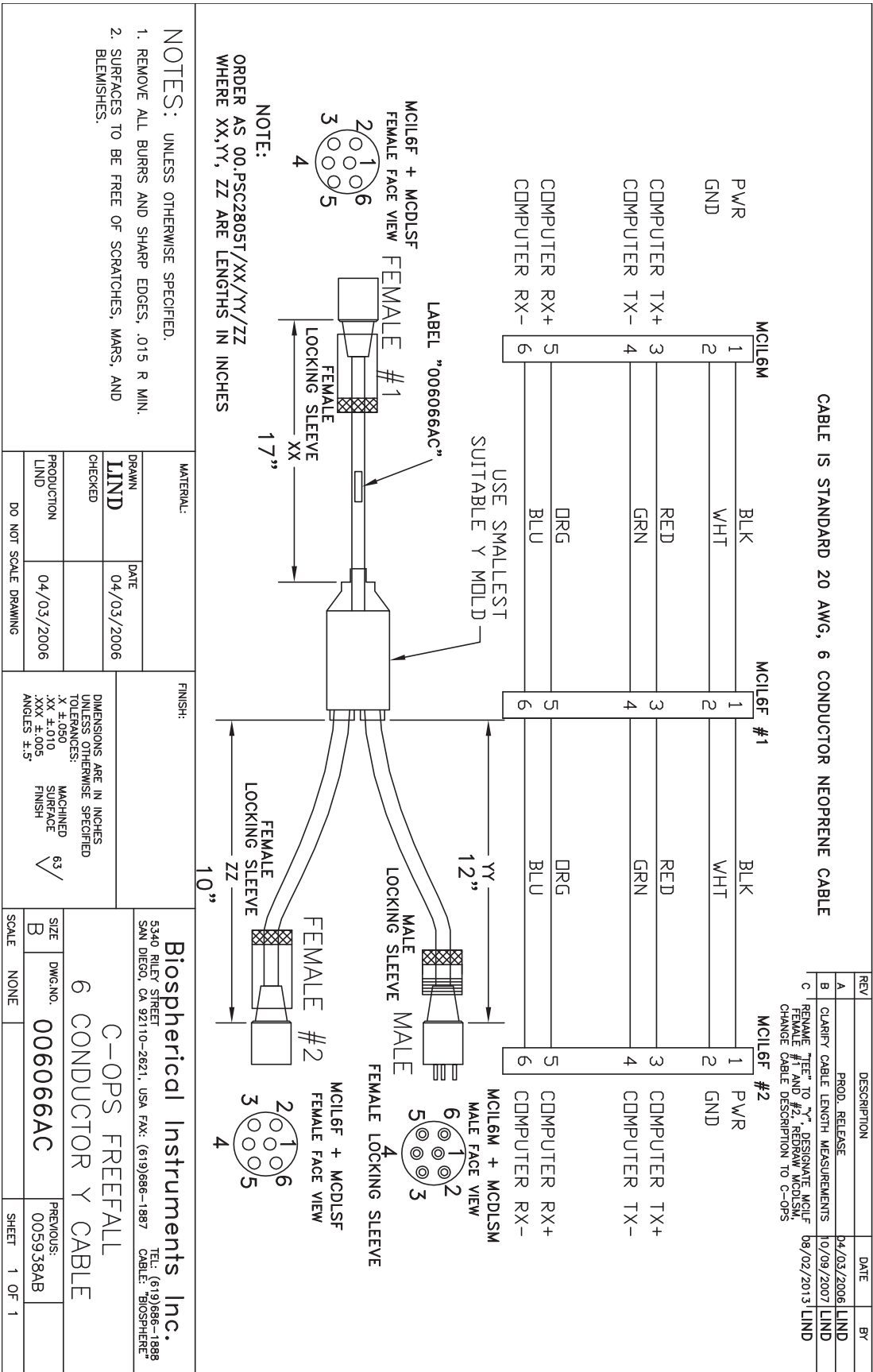

Fig. F6. A C-OPS backplane Y-cable.



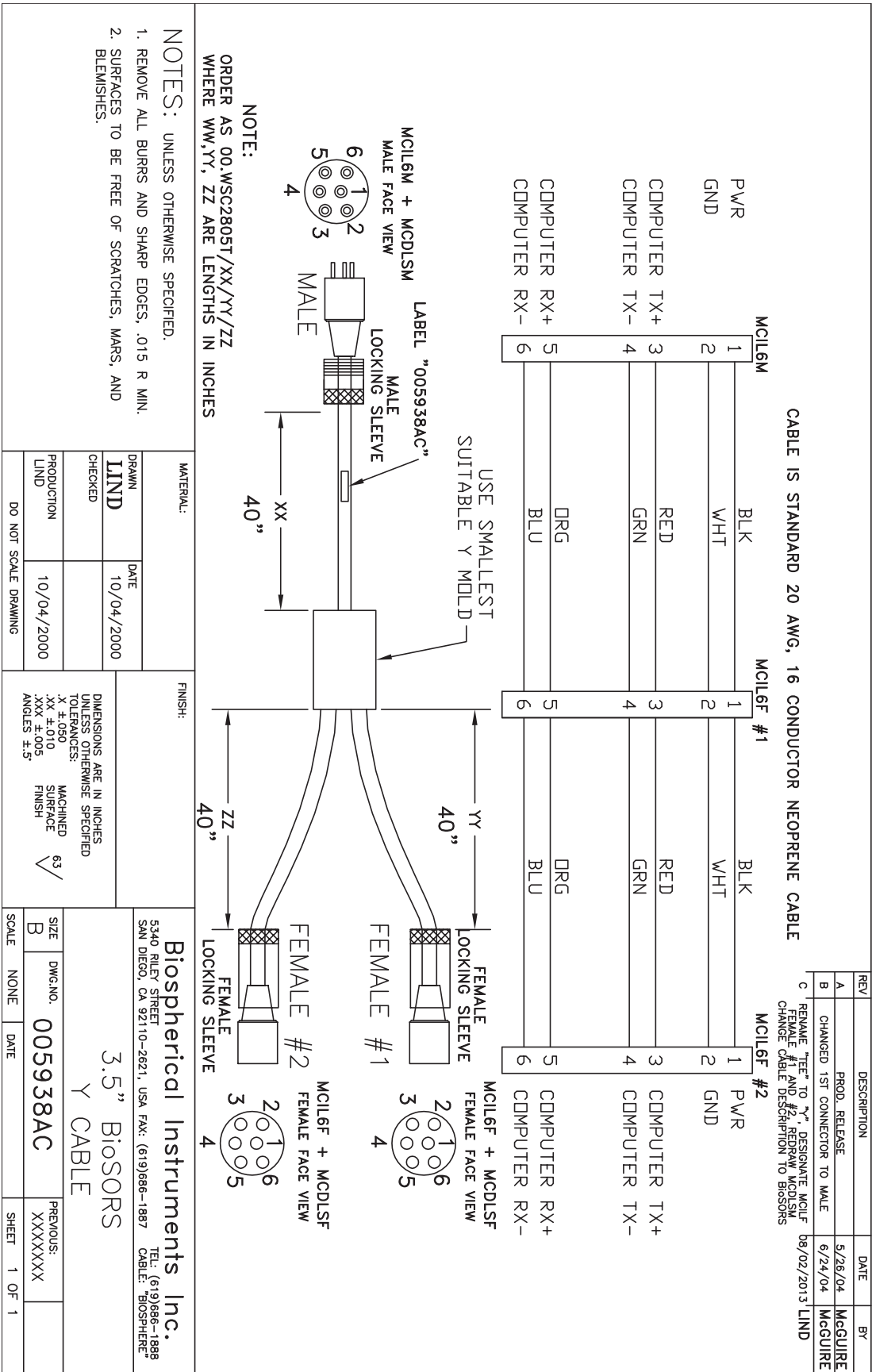

Fig. F7. A BioSCAN frame Y-cable.

## Mobilization Protocols for HySEAS Observations

### GLOSSARY

|          |  |          |  |
|----------|--|----------|--|
| AC       | Alternating Current  | GEO-CAPE | Geostationary Coastal and Air Pollution Events                                     |
| ADC      | Analog-to-Digital Converter  | GMT      | Greenwich Mean Time  |
| AFFF     | Aqueous Film-Forming Foam  | GPO      | Government Printing Office   |
| AGM      | Absorbent Glass Mat  | GPS      | Global Positioning System  |
| AIS      | Automatic Identification System                                    | GSFC     | Goddard Space Flight Center  |
| AOPs     | Apparent Optical Properties  | HySEAS   | Hybrid Sensors for Environmental AOP Sampling (HySEAS)                             |
| ASB      | Arctic Survey Boat   | IAU      | International Astronomical Union   |
| AWG      | American Wire Gauge  | ICAO     | International Civil Aviation Organization  |
| BAR      | Boating Accident Report  | IOPs     | Inherent Optical Properties  |
| BioFLAAT | Biospherical Field Leveling Accessory with Adjustable Trim         | ITU      | International Telecommunication Union  |
| BioGPS   | Biospherical Global Positioning System                             | LJCO     | Lucinda Jetty Coastal Observatory  |
| BioMAST  | Biospherical Mast for Advanced Solar Technologies                  | MERIS    | Medium Resolution Imaging Spectrometer   |
| BioSCAN  | Biospherical Surface and Celestial Acquisition Network             | MOBY     | Marine Optical Buoy  |
| BioSHADE | Biospherical Shadowband Accessory for Diffuse Irradiance           | MODIS    | Moderate Resolution Imaging Spectroradiometer                                      |
| BioSORS  | Biospherical Surface Ocean Reflectance System                      | MP       | Male Pins  |
| BSI      | Biospherical Instruments Inc.                                      | MR       | Male Ridges  |
| C-AIR    | Coastal Airborne In-situ Radiometer                                | N/A      | Not Applicable   |
| CB       | Citizens' Band   | NASA     | National Aeronautics and Space Administration                                      |
| C-BEAMMS | Compact-Buoyant Environmental AOP Measurements of the Moon and Sun | NATO     | North Atlantic Treaty Organization   |
| C-CAPS   | Compact-Conductivity Accessory for Profiling Systems               | NEC      | National Electrical Code   |
| CCW      | Counterclockwise   | NFPA     | National Fire Protection Association   |
| CCGS     | Canadian Coast Guard Ship  | NIR      | Near-Infrared  |
| CDR      | Climate-quality Data Records                                       | NMMA     | National Marine Manufacturers Association  |
| CIRPAS   | Center for Interdisciplinary Remotely-Piloted Aircraft Studies     | NPT      | National Pipe Thread   |
| CLP      | Cleaner Lubricant Preservative                                     | NRC      | National Research Council  |
| C-OPS    | Compact Optical Profiling System                                   | OCULLAR  | Ocean Color Underwater Low Light Advanced Radiometer                               |
| COTS     | Commercial-Off-The-Shelf   | OCTS     | Ocean Color and Temperature Scanner  |
| CPR      | Cardiopulmonary Resuscitation                                      | PARALELS | Passive and Active Radiometers for Advanced Light, Ecosystem, and Littoral Studies |
| C-PrOPS  | Compact-Propulsion Option for Profiling Systems                    | PC       | Personal Computer  |
| CTD      | Conductivity, Temperature, and Depth                               | PCA      | Printed Circuit Assembly   |
| CUT      | Coordinated Universal Time   | PFD      | Personal Flotation Device  |
| CW       | Clockwise  | PMT      | Photomultiplier Tube   |
| DC       | Direct Current   | PROSIT   | Processing of Radiometric Observations of Seawater using Information Technologies  |
| DCM      | Depth of the Chlorophyll Maximum                                   | PSD      | Power Spectral Density   |
| EPF      | Eye Protection Factor  | PTT      | Push-To-Talk or Press-To-Transmit.   |
| EPIRB    | Emergency Position Indicating Radio Beacon                         | QA       | Quality Assurance  |
| FAQ      | Frequently Asked Question  | QC       | Quality Control  |
| FCC      | Federal Communications Commission                                  | RMA      | Return Merchandise Authorization   |
| FFT      | Fast Fourier Transform   | RS       | Recommended Standard   |
| FG       | Female Grooves   | R/T      | Radiotelephone   |
| FS       | Female Sockets   | R/V      | Research Vessel  |
| FVA      | Full View Angle  | SBIR     | Small Business Innovation Research   |
|          |  | SeaBASS  | SeaWiFS Bio-Optical Archive and Storage System                                     |
|          |  | SeaWiFS  | Sea-viewing Wide Field-of-View Sensor  |

|         |   |
|---------|---|
| SIMBIOS | Sensor Intercalibration and Merger for Biological and Interdisciplinary Oceanic Studies |
| SIP     | Silicon Photodetector   |
| SPF     | Sun Protection Factor   |
| SuBOPS  | Submersible Biospherical Optical Profiling System                                       |
| SUV     | Sports Utility Vehicle  |
| T-MAST  | Telescoping Mount for Advanced Solar Technologies                                       |
| TF2E    | Transfluorometer Two-Emission Extension   |
| TR/V    | Training Research Vessel  |
| TUC     | <i>Temps Universel Coordonné</i>  |
| UPS     | Uninterruptible Power Supply  |
| USB     | Universal Serial Bus  |
| USCG    | United States Coast Guard   |
| USCGC   | United States Coast Guard Cutter  |
| USDA    | United States Department of Agriculture   |
| UPF     | Ultraviolet Protection Factor   |
| USB     | Universal Serial Bus  |
| USV     | Unmanned Surface Vessel   |
| UTC     | Coordinated Universal Time  |
| UUV     | Unmanned Underwater Vehicle   |
| UV      | Ultraviolet   |
| VDS     | Visual Distress Signal  |
| VHF     | Very High Frequency   |
| VIIRS   | Visible and Infrared Imaging Radiometer Suite   |
| VIS     | Visible   |
| XTRA    | Expandable Technologies for Radiometric Applications                                    |

## SYMBOLS

|                     |   |
|---------------------|---|
| $E$                 | Irradiance.   |
| $E_d(z, \lambda)$   | The in-water vertical profile of downward irradiance.   |
| $E_d(0^+, \lambda)$ | The downward irradiance above the water surface (the global solar irradiance).                            |
| $E_u(z, \lambda)$   | The in-water vertical profile of upward irradiance.   |
| $I$                 | Current.  |
| $L$                 | Radiance.   |
| $L_i(0^+, \lambda)$ | The indirect sky radiance.  |
| $L_T(0^+, \lambda)$ | The total radiance at the sea surface.  |
| $L_u(z, \lambda)$   | The in-water vertical profile of upwelled radiance.   |
| $L_W(\lambda)$      | The water-leaving radiance.   |
| $Q$                 | The bidirectional function for the radiance field, which is expressed as an irradiance-to-radiance ratio. |
| $Q_n$               | The $Q$ -function for nadir-viewing observations.   |
| $R$                 | Resistance.   |

|             |  |
|-------------|--|
| $t$         | Time.  |
| $V$         | Voltage.   |
| $x$         | The generalized horizontal direction.  |
| $y$         | The generalized meridional direction.  |
| $z$         | The vertical (depth) coordinate.   |
| $z = 0^-$   | A depth immediately below the sea surface (the null depth).                          |
| $z = 0^+$   | A height immediately above the sea surface.  |
| $\vartheta$ | The viewing angle with respect to the vertical.                                      |
| $\lambda$   | Wavelength.  |
| $\phi$      | The solar azimuth angle.   |
| $\phi^-$    | An angle $90^\circ$ CCW (from above) away from the Sun plane, i.e., $\phi - \pi/2$ . |
| $\phi^+$    | An angle $90^\circ$ CW (from above) away from the Sun plane, i.e., $\phi + \pi/2$ .  |

## REFERENCES

- Antoine, D., F. d'Ortenzio, S.B. Hooker, G. Bécu, B. Gentili, D. Tailliez, and A.J. Scott, 2008: Assessment of uncertainty in the ocean reflectance determined by three satellite ocean color sensors (MERIS, SeaWiFS and MODIS-A) at an offshore site in the Mediterranean Sea (BOUSSOLE project). *J. Geophys. Res.*, **113**, C07013, doi:10.1029/2007JC004472, 2008.
- Antoine, D., S.B. Hooker, S. Bélanger, A. Matsuoka, and M. Babin, 2013: Apparent optical properties of the Canadian Beaufort Sea, part I: Observational overview and water column relationships. *Biogeosci.*, **10**, 4,493–4,509.
- Bailey, S.W., S.B. Hooker, D. Antoine, B.A. Franz, P.J. Werdell, 2008: Sources and assumptions for the vicarious calibration of ocean color satellite observations. *Appl. Opt.*, **47**, 2,035–2,045.
- Booth, C.R., J.H. Morrow, R.N. Lind, and S.B. Hooker, 2010: "Development of the Microradiometer." In: Morrow, J.H., S.B. Hooker, C.R. Booth, G. Bernhard, R.N. Lind, and J.W. Brown, 2010: Advances in Measuring the Apparent Optical Properties (AOPs) of Optically Complex Waters. *NASA Tech. Memo. 2010-215856*, NASA Goddard Space Flight Center, Greenbelt, Maryland, 27–41 pp.
- Clark, D., H.R. Gordon, K.J. Voss, Y. Ge, W. Broenkow, and C. Trees, 1997: Validation of atmospheric correction over the oceans. *J. Geophys. Res.*, **102**, 17,209–17,217.
- Doxaran D., J. Ehn, S. Bélanger, A. Matsuoka, S. Hooker, and M. Babin, 2012: Remote sensing the dynamics of suspended particles in the Mackenzie River plume (Canadian Arctic Ocean). *Biogeosci.*, **9**, 3,213–3,229.
- Fichot, C.G., K. Kaiser, S.B. Hooker, R.M.W. Amon, M. Babin, S. Bélanger, S.A. Walker, and R. Benner, 2013: Pan-Arctic views of continental runoff in the Arctic Ocean. *Sci. Rep.*, **3**, 1053, doi:10.1038 /srep01053.
- Ferris, C.D., W.F. Hammett, J.C. Whitaker, and W.E. DeWitt, 2005: "Safety." In: *The Electronics Handbook, Second Edition*, J.C. Whitaker, Ed., CRC Press, Boca Raton, 2,317–2,324.

- Hooker, S.B., 2010: “The Telescoping Mount for Advanced Solar Technologies (T-MAST).” In: Morrow, J.H., S.B. Hooker, C.R. Booth, G. Bernhard, R.N. Lind, and J.W. Brown, *Advances in Measuring the Apparent Optical Properties (AOPs) of Optically Complex Waters. NASA Tech. Memo. 2010-215856*, NASA Goddard Space Flight Center, Greenbelt, Maryland, 66–71.
- , and W.E. Esaias, 1993: An overview of the SeaWiFS project. *Eos, Trans., Amer. Geophys. Union*, **74**, 241–246.
- , C.R. McClain, J.K. Firestone, T.L. Westphal, E-n. Yeh, and Y. Ge, 1994: The SeaWiFS Bio-Optical Archive and Storage System (SeaBASS), Part 1. *NASA Tech. Memo. 104566, Vol. 20*, S.B. Hooker and E.R. Firestone, Eds., NASA Goddard Space Flight Center, Greenbelt, Maryland, 40 pp.
- , G. Zibordi, G. Lazin, and S. McLean, 1999: The SeaBOARR-98 Field Campaign. *NASA Tech. Memo. 1999-206892, Vol. 3*, S.B. Hooker and E.R. Firestone, Eds., NASA Goddard Space Flight Center, Greenbelt, Maryland, 40 pp.
- , and S. Maritorena, 2000: An evaluation of oceanographic radiometers and deployment methodologies. *J. Atmos. Ocean. Technol.*, **17**, 811–830.
- , G. Lazin, G. Zibordi, and S. McLean. 2002. An evaluation of above- and in-water methods for determining water-leaving radiances. *J. Atmos. Oceanic Technol.*, **19**, 486–515.
- , and A. Morel, 2003: Platform and environmental effects on above- and in-water determinations of water-leaving radiances. *J. Atmos. Ocean. Technol.*, **20**, 187–205.
- , G. Zibordi, J-F. Berthon, D. D’Alimonte, D. van der Linde, and J.W. Brown, 2003: Tower-Perturbation Measurements in Above-Water Radiometry. *NASA Tech. Memo. 2003-206892, Vol. 23*, S.B. Hooker and E.R. Firestone, Eds., NASA Goddard Space Flight Center, Greenbelt, Maryland, 35 pp.
- , —, —, and J.W. Brown, 2004: Above-water radiometry in shallow, coastal waters. *Appl. Opt.*, **43**, 4,254–4,268.
- , and —, 2005: Platform perturbations in above-water radiometry. *Appl. Opt.*, **44**, 553–567.
- , C.R. McClain, and A. Mannino, 2007: NASA Strategic Planning Document: A Comprehensive Plan for the Long-Term Calibration and Validation of Oceanic Biogeochemical Satellite Data. *NASA Special Pub. 2007-214152*, NASA Goddard Space Flight Center, Greenbelt, Maryland, 31 pp.
- , R.N. Lind, J.H. Morrow, and J.W. Brown, 2010a: “The Submersible Biospherical Optical Profiling System (SuB-OPS).” In: Morrow, J.H., S.B. Hooker, C.R. Booth, G. Bernhard, R.N. Lind, and J.W. Brown, *Advances in Measuring the Apparent Optical Properties (AOPs) of Optically Complex Waters. NASA Tech. Memo. 2010-215856*, NASA Goddard Space Flight Center, Greenbelt, Maryland, 17–26.
- , J.H. Morrow, and J.W. Brown, 2010b: “The Biospherical Surface Ocean Reflectance System (BioSORS).” In: Morrow, J.H., S.B. Hooker, C.R. Booth, G. Bernhard, R.N. Lind, and J.W. Brown, *Advances in Measuring the Apparent Optical Properties (AOPs) of Optically Complex Waters. NASA Tech. Memo. 2010-215856*, NASA Goddard Space Flight Center, Greenbelt, Maryland, 8–16.
- , G. Bernhard, J.H. Morrow, C.R. Booth, T. Comer, R.N. Lind, and V. Quang, 2012: Optical Sensors for Planetary Radiant Energy (OSPRey): Calibration and Validation of Current and Next-Generation NASA Missions. *NASA Tech. Memo. 2012-215872*, NASA Goddard Space Flight Center, Greenbelt, Maryland, 117 pp.
- , J.H. Morrow, and A. Matsuoka, 2013: Apparent optical properties of the Canadian Beaufort Sea, part II: The 1% and 1 cm perspective in deriving and validating AOP data products. *Biogeosci.*, **10**, 4,511–4,527.
- , and J.W. Brown, 2014: Processing of Radiometric Observations of Seawater using Information Technologies (PROSIT): In-Water User Manual. *NASA Tech. Memo.*, NASA Goddard Space Flight Center, Greenbelt, Maryland, (in prep.).
- Matsuoka, A., S.B. Hooker, A. Bricaud, B. Gentili, and M. Babin, 2012: Estimating absorption coefficients of colored dissolved organic matter (CDOM) using a semianalytical algorithm for southern Beaufort Sea (Canadian Arctic) waters: application to deriving concentrations of dissolved organic carbon from space. *Biogeosci.*, **10**, 917–927.
- Morrow, J.H., S.B. Hooker, C.R. Booth, G. Bernhard, R.N. Lind, and J.W. Brown, 2010a: *Advances in Measuring the Apparent Optical Properties (AOPs) of Optically Complex Waters, NASA Tech. Memo. 2010-215856*, NASA Goddard Space Flight Center, Greenbelt, Maryland, 80 pp.
- , C.R. Booth, R.N. Lind, and S.B. Hooker, 2010b: “The Compact-Optical Profiling System (C-OPS).” In: Morrow, J.H., S.B. Hooker, C.R. Booth, G. Bernhard, R.N. Lind, and J.W. Brown, *Advances in Measuring the Apparent Optical Properties (AOPs) of Optically Complex Waters. NASA Tech. Memo. 2010-215856*, NASA Goddard Space Flight Center, Greenbelt, Maryland, 42–50.
- , S.B. Hooker, G. Bernhard, and R.N. Lind, 2010c: “Scalable Hydro-optical Applications for Light-Limited Oceanography (SHALLO).” In: Morrow, J.H., S.B. Hooker, C.R. Booth, G. Bernhard, R.N. Lind, and J.W. Brown, *Advances in Measuring the Apparent Optical Properties (AOPs) of Optically Complex Waters. NASA Tech. Memo. 2010-215856*, NASA Goddard Space Flight Center, Greenbelt, Maryland, 60–65.
- Mueller, J.L., 2000: “Overview of Measurement and Data Analysis Protocols.” In: Fargion, G.S., and J.L. Mueller, *Ocean Optics Protocols for Satellite Ocean Color Sensor Validation, Revision 2. NASA Tech. Memo. 2000-209966*, NASA Goddard Space Flight Center, Greenbelt, Maryland, 87–97.



- , 2002: “Overview of Measurement and Data Analysis Protocols.” In: Mueller, J.L., and G.S. Fargion, Ocean Optics Protocols for Satellite Ocean Color Sensor Validation, Revision 3, Volume 1. *NASA Tech. Memo. 2002-21004/Rev3-Vol1*, NASA Goddard Space Flight Center, Greenbelt, Maryland, 123–137.
- , 2003: “Overview of Measurement and Data Analysis Methods.” In: Mueller, J.L., and 17 Coauthors, Ocean Optics Protocols for Satellite Ocean Color Sensor Validation, Revision 4, Volume III: Radiometric Measurements and Data Analysis Protocols. *NASA Tech. Memo. 2003-211621/Rev4-Vol.III*, NASA Goddard Space Flight Center, Greenbelt, Maryland, 1–20.
- , and R.W. Austin, 1992: Ocean Optics Protocols for SeaWiFS Validation. *NASA Tech. Memo. 104566, Vol. 5*, S.B. Hooker and E.R. Firestone, Eds., NASA Goddard Space Flight Center, Greenbelt, Maryland, 43 pp.
- , and —, 1995: Ocean Optics Protocols for SeaWiFS Validation, Revision 1. *NASA Tech. Memo. 104566, Vol. 25*, S.B. Hooker, E.R. Firestone, and J.G. Acker, Eds., NASA Goddard Space Flight Center, Greenbelt, Maryland, 66 pp.
- National Aeronautics and Space Administration, 2010: *Responding to the Challenge of Climate and Environmental Change: NASA’s Plan for a Climate-Centric Architecture for Earth Observations and Applications from Space*. National Aeronautics and Space Administration, Washington, DC, 48 pp.
- NEC, 2011: *National Electrical Code Handbook, Twelfth Edition*. M.W. Earley and J.S. Sargent, Eds., and C.D. Coache and R.J. Roux, Contribs., National Fire Protection Association, Quincy, 1,497 pp.
- NRC, 2007: *Earth Science and Applications from Space: National Imperatives for the Next Decade and Beyond*. The National Academies, Washington, DC, 456 pp.
- Parker, C.D., 2009: In: *Encyclopedia of Electrochemical Power Sources*, Garcke, J., C. Dyer, P. Moseley, Z. Ogumi, D. Rand, and B. Scrosati ,Eds., Elsevier, Amsterdam, 225–232 pp.





