

# Atmospheric Processing Module for Mars Propellant Production

A. Muscatello<sup>1</sup>, R. Devor<sup>2</sup> and J. Captain<sup>3</sup>

<sup>1</sup>Applied Chemistry Laboratory, Surface Systems Office, NE-S-2, National Aeronautics and Space Administration, Kennedy Space Center, FL 32899; Ph (321) 867-3498; email: [anthony.c.muscatello@nasa.gov](mailto:anthony.c.muscatello@nasa.gov)

<sup>2</sup>Applied Science and Technology Group, ESC-870, QinetiQ NA, Kennedy Space Center, FL 32899; Ph (321) 867-4985; email: [robert.w.devor@nasa.gov](mailto:robert.w.devor@nasa.gov)

<sup>3</sup>Applied Science and Technology Group, ESC-870, QinetiQ NA, Kennedy Space Center, FL 32899; Ph (321) 867-8185; email: [james.g.captain@nasa.gov](mailto:james.g.captain@nasa.gov)

## ABSTRACT

The multi-NASA center Mars Atmosphere and Regolith Collector/Processor for Lander Operations (MARCO POLO) project was established to build and demonstrate a methane/oxygen propellant production system in a Mars analog environment. Work at the Kennedy Space Center (KSC) has focused on the Atmospheric Processing Module (APM). The purpose of the APM is to freeze carbon dioxide from a simulated Martian atmosphere at Martian pressures (~8 torr) by using dual cryocoolers. The resulting pressurized CO<sub>2</sub> and hydrogen are fed to a Sabatier subsystem to make methane and water vapor. This paper covers (1) the design and selection of major hardware items, such as the cryocoolers, pumps, tanks, chillers, and membrane separators, (2) the determination of the optimal cold head design and flow rates needed to meet the collection requirement of 88 g CO<sub>2</sub>/hr for 14 hr, (3) the testing of the CO<sub>2</sub> freezer subsystem, and (4) testing of the Sabatier subsystem.

## INTRODUCTION

“Living off the land” with resources indigenous to a planetary body such as Mars, or *in situ* resource utilization (ISRU), requires mission-enabling capabilities that will be a necessary part of further exploration of the solar system. It is vital to demonstrate the practicality of these technologies for future Martian missions. Current work, focusing on developing a first-generation Mars ISRU demonstration lander for atmospheric and soil processing operations, is being performed as a multicenter NASA effort. Known as the MARCO POLO project (for Mars Atmosphere and Regolith Collector/Processor for Lander Operations) (Interbartolo, 2012), this work is aimed at using Martian resources to produce methane, oxygen, and hydrogen for use as rocket propellant and fuel cell consumables. The mission goals of the MARCO POLO project align with the “game-changing” technology objectives put forth by NASA headquarters; ISRU will open the solar system to a broader range of missions than would be possible if everything had to be brought along for the ride—and MARCO POLO’s space mining and resource utilization technologies are essential for achieving ISRU on Mars.

The MARCO POLO lander will provide a demonstration platform for all aspects of Martian soil and atmospheric processing, beginning with the capture of carbon dioxide ( $\text{CO}_2$ ) from the Martian atmosphere to produce methane ( $\text{CH}_4$ ) and the extraction of water from Martian soil, which would then be electrolyzed into hydrogen ( $\text{H}_2$ ) and oxygen ( $\text{O}_2$ ). The lander is designed in a modular fashion with an Atmospheric Processing Module (APM), Soil Processing Module, Water Cleanup Module, Water Processing Module, and Power Production Module. The proposed layout of the MARCO POLO lander is shown in Figure 1a.

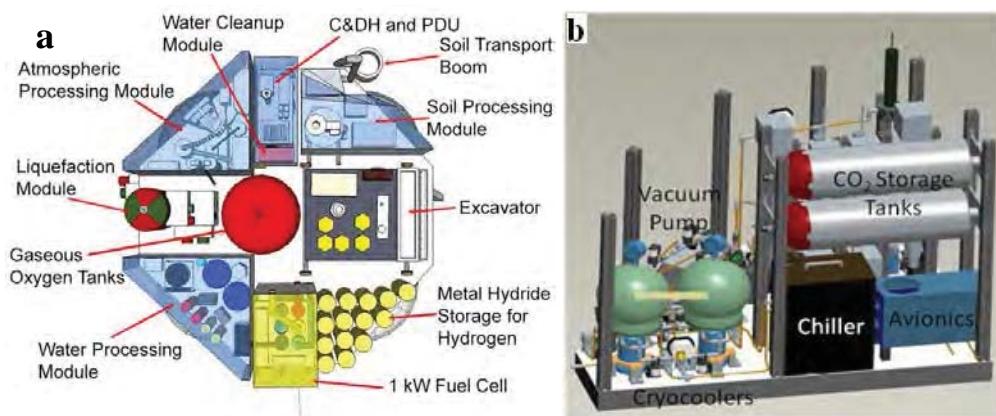

Figure 1. (a) The proposed MARCO POLO system configuration and (b) a 3-D model of the APM

Originally, the primary goal of the MARCO POLO project was to design, build, and test an end-to-end Mars ISRU atmospheric and soil processing system. This system would be powered by mission-relevant DC power and be capable of closed-loop power production through the use of a fuel cell and electrolyzer, as well as producing  $\text{O}_2$  and  $\text{CH}_4$  for use with a thruster (to demonstrate the end-to-end Mars resource-to-thrust concept). The original demonstration was to take place on the Mauna Kea volcano in Hawaii, at a site used for other analog ISRU demonstrations. Later, the location was changed to the Johnson Space Center (JSC) Planetary Analog Site, using Mars simulant. However, a change in direction during 2012 resulted in the cancellation of the field demonstration of the MARCO POLO lander and a reduction in scope to produce only a laboratory-scale demonstration unit, at least for the time being, with the potential for a future field demonstration.

## ATMOSPHERIC PROCESSING MODULE

This paper focuses on the APM (shown in Figure 1b), whose primary function is to capture  $\text{CO}_2$  from the Martian atmosphere (separating it from the other atmospheric gases) and convert it into  $\text{CH}_4$ , using a Sabatier reactor. Originally, several different technologies were evaluated as possible techniques for  $\text{CO}_2$  capture and gas separation, including freezing, membrane separation, ionic liquids, acid-base chemistry, and molecular sieves or other types of preparative chromatography. A thorough literature search was performed on all of these possible options, and the various pros and cons were identified and evaluated (Muscatello, 2011). In the end,

CO<sub>2</sub> freezing was chosen as the most promising option to pursue for several reasons. These include the ability to obtain relatively pure CO<sub>2</sub> at high pressures, as well as provide an enriched feedstock for buffer gas preparation, which is a benefit not offered by other separation options. In addition, freezing is well understood and simpler than the other processes. The Mars atmosphere consists of 95.32% CO<sub>2</sub>, 2.7% nitrogen, 1.6% argon, and trace amounts of water, carbon monoxide, and several other gases. The initial step in this process is to separate and capture CO<sub>2</sub>. At 7 millibars, the average pressure on the Martian surface, the freezing point of CO<sub>2</sub> is 150 K (-123°C), which makes it necessary to use a cryocooler as the condensation method.

At this temperature and pressure, all of the other constituents, except the water, will remain in the gas phase. Fortunately, the concentration of the water is so low that only about 1 g of water will be captured for every 700 g of CO<sub>2</sub> that is captured, and such low levels will not detrimentally affect the Sabatier conversion process. The current requirements call for 1.24 kg of CO<sub>2</sub> to be collected during the 14 hours of daytime operation, which will provide the 88 g of CO<sub>2</sub> per hour necessary for the Sabatier reactor system. The collected CO<sub>2</sub> will be allowed to sublime to provide sufficient pressure (50 psi) for the Sabatier reactor to function. To accommodate the need to collect CO<sub>2</sub> at the same time the Sabatier reactor is operating; dual cryocoolers are needed to operate in tandem (one collecting CO<sub>2</sub> while the other is supplying the Sabatier reactor) on a 14-hour duty cycle. This will allow for one duty cycle per 14-hour Martian “day” and provide a continuous supply of CO<sub>2</sub> to the Sabatier subsystem of the APM. The system will revert to a dormant, reduced power state for the Martian “night.” Current plans allow for a total of 850 W during the “day” and only 50 W during the “night.” The system was built to provide 24 VDC power conversion.

## CO<sub>2</sub> FREEZER SUBSYSTEM

The CO<sub>2</sub> Freezer subsystem was built around the dual cryocoolers used to separate gases from the simulated Martian atmosphere. Prior work (Zubrin, 2013) found that Sunpower Cryotel Model GT cryocoolers (Figure 2) have the proper lift, low mass and power, and space flight heritage for a similar model. Sunpower data shows the GT model provides 34 W lift at 150 K. Two GT units were installed in the APM test bed (Figure 3). Initial laboratory work began with the design of an efficient cryocooler cold head to collect the maximum amount of CO<sub>2</sub> during the 14-hour cycle time. Several factors had to be taken into account, such as geometry, available surface area (SA), and thermal mass



Figure 2. Sunpower GT cryocooler

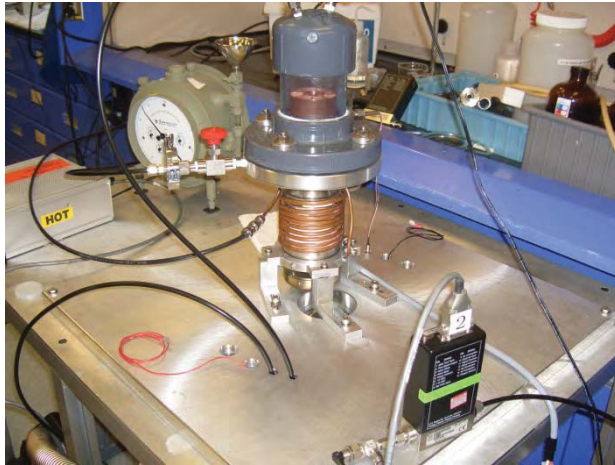

Figure 3. Cryocooler head testing apparatus

(TM). Several different geometries were designed and tested to determine the most efficient. The three designs that were tested are shown in Figure 4. The “orange slicer” has an SA of 2,472 cm<sup>2</sup> and a TM of 1,296 g, the “starburst” has an SA of 192 cm<sup>2</sup> and a TM of 260 g, and the “Ferris Wheel” has an SA of 299 cm<sup>2</sup> and a TM of 254 g. These cryocooler heads were tested with the Sunpower Cryotel GT cryocooler, using pure CO<sub>2</sub> at ~8 torr. The cryocooler head designs evolved as testing

showed the first two designs did not meet the requirements.

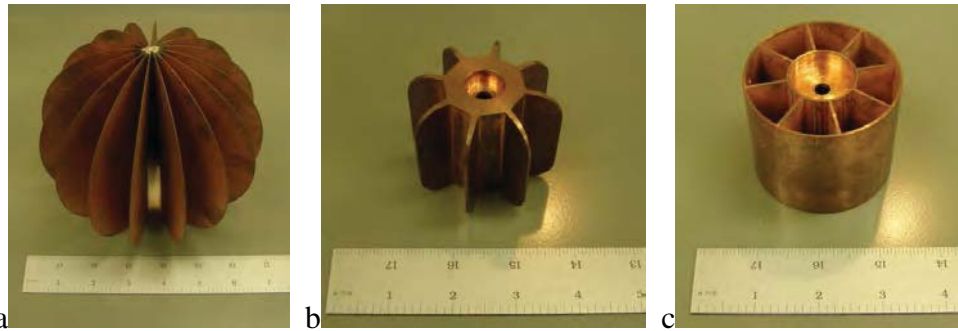

Figure 4. Cryocooler cold head configurations: (a) orange slicer, (b) starburst, and (c) Ferris Wheel

The first cryocooler head that was tested was the orange slicer, which was based on prior work at Lockheed Martin to freeze CO<sub>2</sub> (Clark, 2001). The cold head was scaled up to have eight fins with a diameter of 15.24 cm, which was calculated to be large enough to freeze 1.232 kg of CO<sub>2</sub> in 14 hr. Unfortunately, even in pure CO<sub>2</sub>, this design did not capture the 88 g/hr necessary to supply the Sabatier subsystem. To solve this problem and other issues with the cost and mass of commercial high pressure vessels to contain the cold heads and the sublimated CO<sub>2</sub>, the design was changed to alternate the two cryocoolers on a 1.4 hr cycle and collect the sublimated CO<sub>2</sub> in two commercial storage tanks (10 liters each) using a pump to increase the pressure in the tanks as high as 100 psia. The 100 psia pressure was selected to allow overnight storage of 247 g of CO<sub>2</sub> so an immediate supply of CO<sub>2</sub> to the Sabatier reactor at 50 psia during daily startup operations of the full APM, before a new batch of sublimating CO<sub>2</sub> was available. The short 1.4-hour duty cycle reduced the CO<sub>2</sub> batch size to 123.2 g, which could be accommodated by a much smaller, lighter cold head.

This led to the starburst design, which had only 20% of the thermal mass of the orange-slicer design and could be machined from a single block of 5.33 cm OD x 6.35 cm L solid copper with 0.26 cm thick fins to improve thermal conductivity. The starburst design proved capable of capturing ~110 g of CO<sub>2</sub> per hour when pure CO<sub>2</sub> was used. At this point, testing using a Mars simulant gas began. Unfortunately, results were not as favorable with this simulant gas mixture. An average of only ~70 g of CO<sub>2</sub> was collected per hour by the starburst design, using the Mars simulant gas. This led to the design of the “Ferris Wheel” cryocooler head, machined from a 6.25 cm OD x 5.33 cm L copper block with eight-1.65 cm wide x 0.127 cm thick fins connecting the 0.127 cm thick outer cylinder and the 0.127 cm thick inner cylinder. The “Ferris Wheel” had two major advantages over the starburst cryocooler head: it had a lower thermal mass (254 g vs. 260 g) and a >200% larger surface area (409 cm<sup>2</sup> vs. 192 cm<sup>2</sup>). Tests (e.g. Figure 5) showed that only the “Ferris Wheel” design was capable of capturing the required 88 g of CO<sub>2</sub> per hour at the expected pressure of ~8 torr, using the Mars simulant gas. A variety of flow rates were tested using the simulant gas at ~8 torr to determine which flow rate could be used to capture the maximum amount of CO<sub>2</sub> at the highest level of efficiency. Figure 6 shows that this design is capable of capturing ~94 g of CO<sub>2</sub> per hour from Mars simulant gas and has a capture efficiency of ~64% at a flow rate of 1.4 L/min.



Figure 5. Ferris wheel cryohead with solid CO<sub>2</sub>

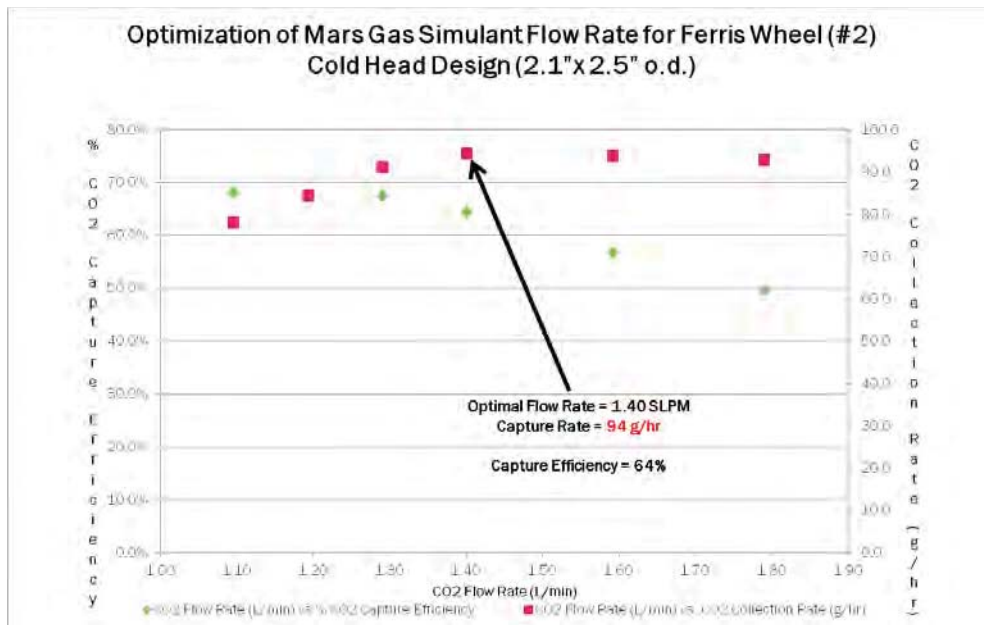

Figure 6. Ferris wheel plot of optimization data (CO<sub>2</sub> capture vs. efficiency)

With the design of a cryocooler head capable of capturing sufficient CO<sub>2</sub> to supply the Sabatier subsystem complete, work began on assembling the automated test bed system for the APM. The original plan called for the automated test bed to be constructed on an octagonal platform to match the lander footprint with an area of ~9,000 cm<sup>2</sup>. However, after the field demonstration of the MARCO POLO project was canceled, the CO<sub>2</sub> freezer (as well as the Sabatier subsystem) was built onto a rectangular platform mounted on a moveable cart, sized to allow easier transport in our laboratory. Built with 80/20 hardware, the unit has multiple vertical levels that allow for optimal use of space. The fluid diagram for the CO<sub>2</sub> Freezer subsystem is shown in Figure 7.

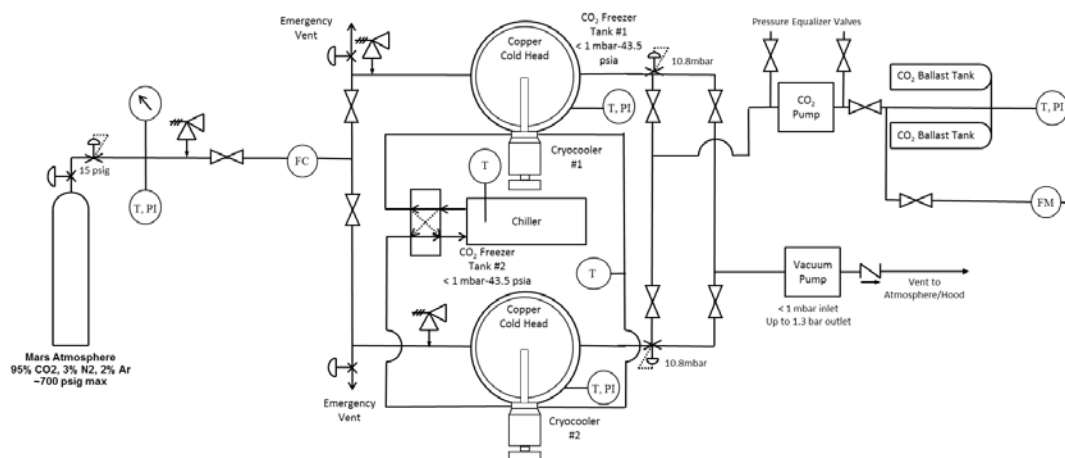
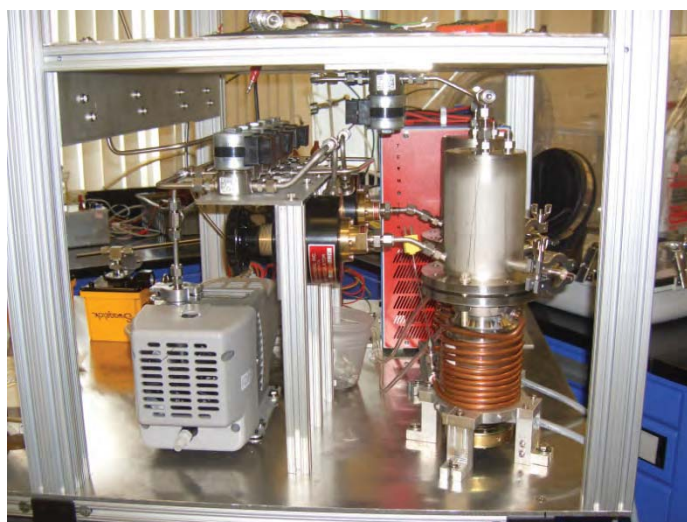

Figure 7. Fluid diagram for the CO<sub>2</sub> Freezer subsystem

Stainless steel cylinders for the cryocoolers were designed and built, and fittings were welded on as necessary. Latching solenoid valves were obtained from Peter Paul Electronics Co. The system is controlled using a National Instruments CompaqRIO data acquisition system and a LabVIEW interface. Figure 8 shows the CO<sub>2</sub> Freezer Subsystem under construction.



*Figure 9. CO<sub>2</sub> Freezer Subsystem Under Construction*

### **CO<sub>2</sub> FREEZER SUBSYSTEM**

Figure 10 shows the completed CO<sub>2</sub> Freezer subsystem. (The recirculation chiller is missing from the system in this image; it had been removed and sent back to the manufacturer for repair.) All testing discussed below was conducted using the completed LabVIEW interface and either pure CO<sub>2</sub> or the low-fidelity Mars atmospheric simulant gas (95% CO<sub>2</sub>, 3% N<sub>2</sub>, and 2% Ar). The primary goal was to operate the subsystem with the fully functional LabVIEW interface and verify that the system was capable of capturing the required 88 g of CO<sub>2</sub> per hour in the 84-minute cycle currently planned. In addition, this testing was designed to reveal whether the current design would also allow the captured CO<sub>2</sub> to be sublimed during the 84-minute cycle, using the installed heaters.



*Figure 10. APM test bed, CO<sub>2</sub> Freezer subsystem (FY13)*

Multiple test runs were performed with this subsystem at different feed rates, and the data from those runs are shown in Figure 11. The CO<sub>2</sub> Freezer subsystem demonstrated capturing an average of 100.3 g CO<sub>2</sub>/hr in 1.4 hr at a total feed rate of 1.2 SLPM, well above the required rate of 88 g/hr. This performance is better than found in the test stand (94 g/hr at 1.4 SLPM). The CO<sub>2</sub> capture fraction averaged 76% under the same conditions. In many of the runs, the CO<sub>2</sub> Freezer subsystem sublimed most, if not all, of the captured CO<sub>2</sub> in the requisite 84-minute cycle. A notable exception is the most recent runs where the sublimation rate fell below 88 g/hr. This is most likely a result of using the CO<sub>2</sub> pump to pull a vacuum while forcing the CO<sub>2</sub> out through a wet test meter. The extra gas present in the cryochamber during sublimation causes convection. This convection, combined with the radiation of heat from the walls of the chamber, warms the frozen CO<sub>2</sub> faster and speeds up sublimation. Using the pump neutralizes the convection. It is interesting to note that, in two runs using the CO<sub>2</sub> pump to pull a vacuum while forcing CO<sub>2</sub> out through the wet test meter did produce an acceptable sublimation rate (greater than 88 g/hr); more testing will need to be done to fully understand this phenomenon.

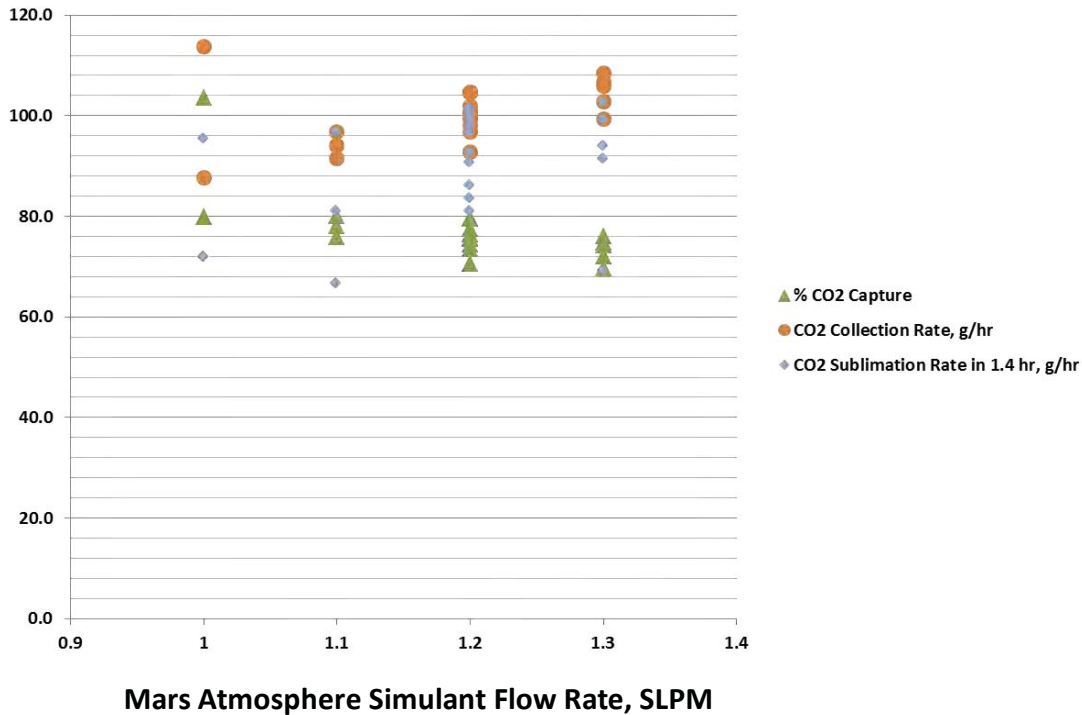

Figure 11. CO<sub>2</sub> Freezer subsystem testing results

To date, the only untested portion of the CO<sub>2</sub> Freezer is its capability to pressurize the CO<sub>2</sub> tanks by subliming CO<sub>2</sub> from the cryochambers. A dual solenoid pump from PumpWorks (LX Thruster™) capable of 150 psid pressure and of pulling 18-25”Hg (167-404 mbar) vacuum at the required flow rate. A few scouting tests with the solenoid pump showed that it could reach high pressures, but that it was loud. Not enough resources remained to test it fully.

## SABATIER SUBSYSTEM

The initial Sabatier subsystem was based upon a modified, simplified, straight-through design. The system was built around a Sabatier reactor obtained from JSC (shown in Figure 12), although all other components were procured by KSC. Testing of the reactor at JSC had shown that it operated as designed and that the optimal conditions for meeting the MARCO POLO production rate of 32 g CH<sub>4</sub>/hr were a ratio of 4.5:1 of H<sub>2</sub> to CO<sub>2</sub>, with a flow rate of 88 g CO<sub>2</sub>/hr or 0.747 SLPM CO<sub>2</sub> and 3.36 SLPM H<sub>2</sub>. Initial attempts to operate the Sabatier reactor at these flow rates resulted in an exotherm that exceeded the maximum operating temperature of 600°C. Thus, the Sabatier reactor was run under a variety of conditions in an attempt to determine the optimal settings for methanation to occur. Several parameters were changed over the course of the tests: the internal heater set point, the flow rates of H<sub>2</sub> and CO<sub>2</sub>, the application of an external heater, and the application of insulation. The flow rates of H<sub>2</sub> and CO<sub>2</sub> were initially kept at a 4:1 ratio, respectively, with CO<sub>2</sub> flows as low as 0.25 L/min and as high as 1 L/min. The internal heater’s set point was varied between 200 °C and 550 °C, and heat tape was wrapped around the reactor,



which was being supplied power from a Variac. In the final few experiments, the external heater was removed and insulation was added. The only constant condition during all experiments was that no pressure regulation was used in the reactor; the reactor was always supplied with H<sub>2</sub> and CO<sub>2</sub> at 25 psig and was vented directly into a fume hood at 0 psig. The original plan was to run the experiments at elevated pressure in the reactor (50 psia); however, difficulty in controlling the exotherm of the methanation reaction called for a reevaluation of this experimental parameter. Figure 13 shows the current APM configuration of the Sabatier subsystem. The Sabatier reactor is on the right with motorized valves in the center.

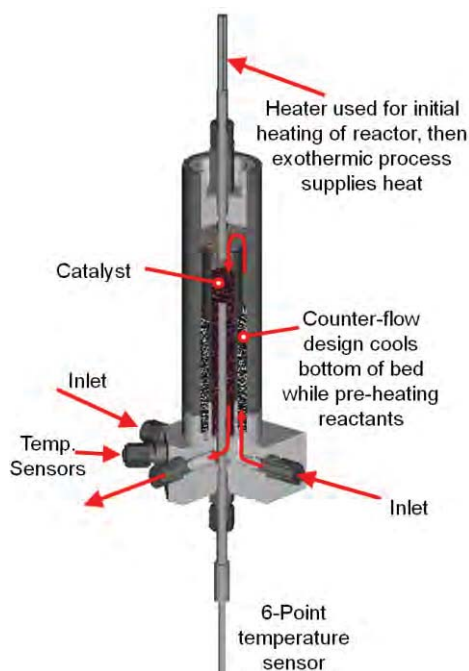

Figure 12. JSC Sabatier Reactor Drawing



Figure 13. APM test bed, Sabatier subsystem

Many of the experimental conditions were repeated in multiple tests; however, the only similar result from these experiments was the over-temperature condition that occurred in the reactor, in all but one test, when the reaction became highly exothermic ( $T_{\max} > 600^{\circ}\text{C}$ ). No correlation could be made between any of the temperature readings on the internal multipoint thermocouple and the time when the reaction became highly exothermic. In general, it was advantageous to use the external heater because it allowed starting the reaction more quickly than when only the internal heater was used. Similar results were achieved by using insulation, but because the reaction was regularly overheating, insulation is unlikely to be used around the reactor.

In one run, an over-temperature condition did not occur soon after the reactor became highly exothermic. This was when the flow rates for H<sub>2</sub> and CO<sub>2</sub> were 1 L/min and 0.25 L/min, respectively. The internal heater was set to 500°C at the same time that the external heater was on. After an initial temperature spike, the rate of increase slowed around 560°C. It continued to rise slowly for more than 30 minutes, without reaching the 600°C shutdown mark, before the external heater was manually turned off to determine the effect this would have on the system. After an initial drop in temperature, the flow rate of CO<sub>2</sub> was increased to 0.5 L/min, which caused an

immediate over-temperature condition and a system shutdown. An attempt to replicate these experimental conditions did not result in the same temperature leveling, but instead the over-temperature condition that was seen in all of the other tests occurred. It did not appear that the thermal profile is the same between the two runs. This has led to the conclusion that there may be channeling or packing issues occurring within the catalyst itself inside of the Sabatier reactor, which could cause inconsistent results.

Additional runs were made to replicate testing performed at JSC, where a flow rate of 3.36 L/min of H<sub>2</sub> and 0.747 L/min of CO<sub>2</sub> were (4.5:1 H<sub>2</sub>:CO<sub>2</sub> ratio). The reactor was initially heated to 160°C, and an exothermic reaction was not observed (indicative that methanation did not occur). The heater temperature was increased incrementally, and an exothermic reaction was seen at a temperature of 230°C, although the reaction was still difficult to control. The same test was performed after regenerating the Sabatier catalyst, with similar results as before.

The last set of tests performed using the JSC Sabatier reactor was to simulate the recirculation of excess gas by passing additional nitrogen (up to a total volume of 10 L/min). It was hoped that the additional gas may exert a cooling effect which would allow for better control of the temperature in the reactor (preventing the overheating that was seen during other tests); however the same issue occurred even with the additional gas flow. The inconsistent results observed during the multitude of Sabatier runs suggests that channeling may be occurring within the Sabatier catalyst itself. Unfortunately, the design of the JSC reactor does not allow for direct examination or replacement of the catalyst because it is welded closed. To overcome these issues, a new reactor was designed for use at KSC. This reactor was built using COTS equipment for both ease of assembly and cost-effectiveness. Details cannot be shared because it is based on a proprietary design.

To improve the efficiency of conversion of CO<sub>2</sub> and to recover unreacted H<sub>2</sub> in the Sabatier subsystem, a recycling process was added to the simple once-through subsystem tested above. A membrane module and a compressor were added to separate the methane product from residual CO<sub>2</sub> and H<sub>2</sub> after the water product was condensed, then compress the CO<sub>2</sub> and H<sub>2</sub> to send them back through the Sabatier reactor. The recycling design was based on a similar system operated at Pioneer Astronautics (Zubrin, 2013). The hardware was installed, but the project ended before the new Sabatier reactor could be tested with it. Figure 14 shows the design of the Sabatier Subsystem with the recycling process added.

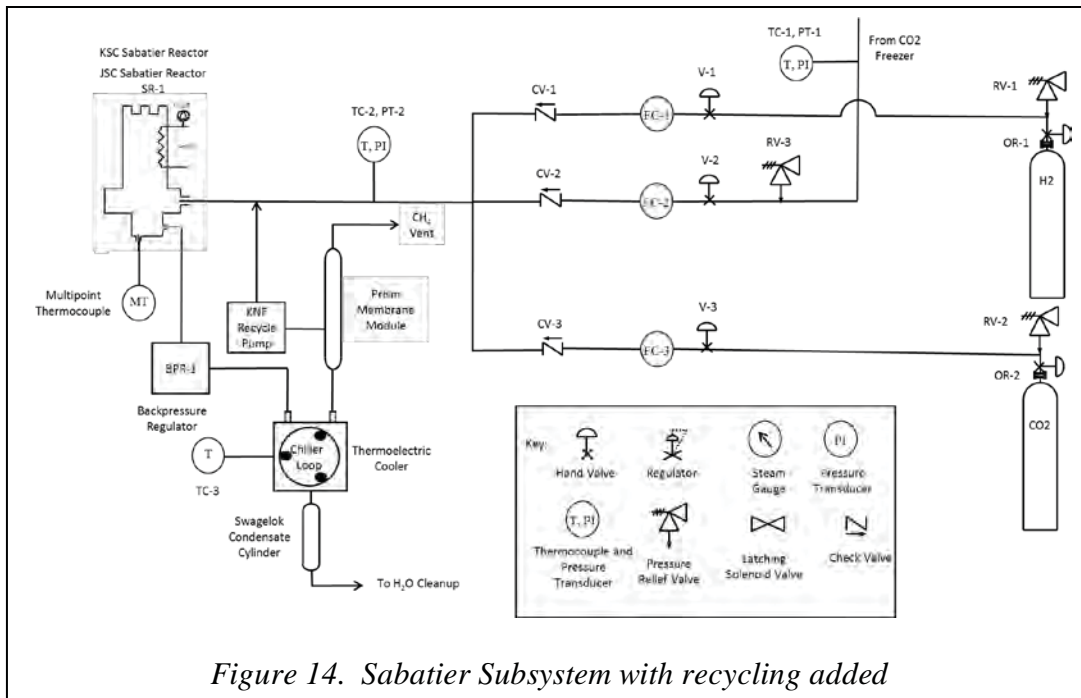

## CONCLUSIONS

The MARCO POLO Atmospheric Processing Module was built and tested. The CO<sub>2</sub> Freezer subsystem was successfully automated, and is capable of capturing and supplying more than the required 88 g/hr of carbon dioxide from a low-fidelity Mars atmospheric simulant gas. The Sabatier subsystem was designed and built, but the JSC Sabatier reactor experienced difficulty in controlling the reaction, leading to the design of a new reactor which is expected to mitigate the overheating. The Sabatier subsystem was also automated. In addition, a recirculation system was incorporated into the Sabatier subsystem to recycle excess hydrogen and improve CO<sub>2</sub> conversion rates since the recycled hydrogen will increase the hydrogen/carbon dioxide ratio.

## FUTURE WORK

Future work will focus on the testing and optimization of the Sabatier reactor. The primary goal will be to test membrane module and recirculation pump to recover unreacted H<sub>2</sub> and CO<sub>2</sub> and integrating the upgraded Sabatier system with the existing CO<sub>2</sub> Freezer subsystem, as well as performing validation testing of the system. Testing will use high-fidelity Mars simulant atmospheric gas.

## REFERENCES

Clark, D. L., Payne, K. S., and Trevathan, J. R. (2001). "Carbon dioxide collection and purification system for Mars." *AIAA 2001-4660*, AIAA Space 2001 Conference and Exposition, Albuquerque, NM.

Interbartolo III, M. A., Sanders, G. B., Oryshchyn, L., Lee, K., Vaccaro, H., Santiago-Maldonado, E., and Muscatello, A. C. (2012). "Prototype Development of an Integrated Mars Atmosphere and Soil-Processing System." *Journal of Aerospace Engineering*, 26, 57-66.

Muscatello, A. C., Santiago-Maldonado, E., Gibson, T., Devor R., and Captain, J., "Mars Atmospheric Capture and Gas Separation," *AIAA 2011-7349*, AIAA SPACE 2011 Conference & Exposition, 27 - 29 September 2011, Long Beach, California.

Zubrin, R., Muscatello, A., and Berggren, M. (2013). "Integrated Mars In Situ Propellant Production System." *J. Aerosp. Eng.* 26, 43-56.