

DESIGN AND PRELIMINARY TESTING OF THE INTERNATIONAL DOCKING ADAPTER'S PERIPHERAL DOCKING TARGET

Christopher W. Foster,^{*} Johnathan M. Blaschak[†], Erin A. Eldridge[‡], Jack P. Brazzel^{**}, and Peter T. Spehar^{***}

The International Docking Adapter's Peripheral Docking Target (PDT) was designed to allow a docking spacecraft to judge its alignment relative to the docking system. The PDT was designed to be compatible with relative sensors using visible cameras, thermal imagers, or Light Detection and Ranging (LIDAR) technologies. The conceptual design team tested prototype designs and materials to determine the contrast requirements for the features. This paper will discuss the design of the PDT, the methodology and results of the tests, and the conclusions pertaining to PDT design that were drawn from testing.

INTRODUCTION

The International Docking Adapter (IDA) will be the module used for docking any of the Commercial Crew vehicles to the International Space Station (ISS). Since there are multiple sensor technologies for determining relative alignment for rendezvous and docking, the IDA asked the IDA Docking Targets team to come up with requirements for a Peripheral Docking Target (PDT) to be compatible with any relative navigation sensor technology currently planned or in use. This docking target would be located outside the docking ring as shown in Figure 1 and would provide assets both for automated systems to determine the relative alignment between the vehicle and docking port and for crew situational awareness for monitoring the automated system. To refine the requirements for the PDT, the ISS program authorized the production of engineering prototypes to be tested. This report describes the engineering prototypes and the tests that were performed with them to assess their feasibility as solutions for the final PDT design.

DESIGN AND PROTOTYPES

The Peripheral Docking Target (Figure 2) was designed according to four main constraints. First, the PDT was designed to be launched in place on the International Docking Adapter. This

^{*} Rendezvous GN&C Engineer, Aerosciences and Flight Mechanics Section, Jacobs Engineering, 2224 Bay Area Blvd, Houston, TX 77058.

[†] On Orbit GN&C Engineer, Aerosciences and Flight Mechanics Section, Jacobs Engineering, 2224 Bay Area Blvd, Houston, TX 77058.

[‡] On Orbit GN&C Engineer, Aerosciences and Flight Mechanics Section, Barrios Technology, 2224 Bay Area Blvd, Houston, TX 77058.

^{**} Branch Chief, GN&C Autonomous Flight Systems Branch, Mail Code EG6, NASA Johnson Space Center, 2101 NASA Parkway, Houston, TX 77058.

^{***} Sr. Engineer, GN&C Autonomous Flight Systems Branch, Mail Code EG6, NASA Johnson Space Center, 2101 NASA Parkway, Houston, TX 77058.

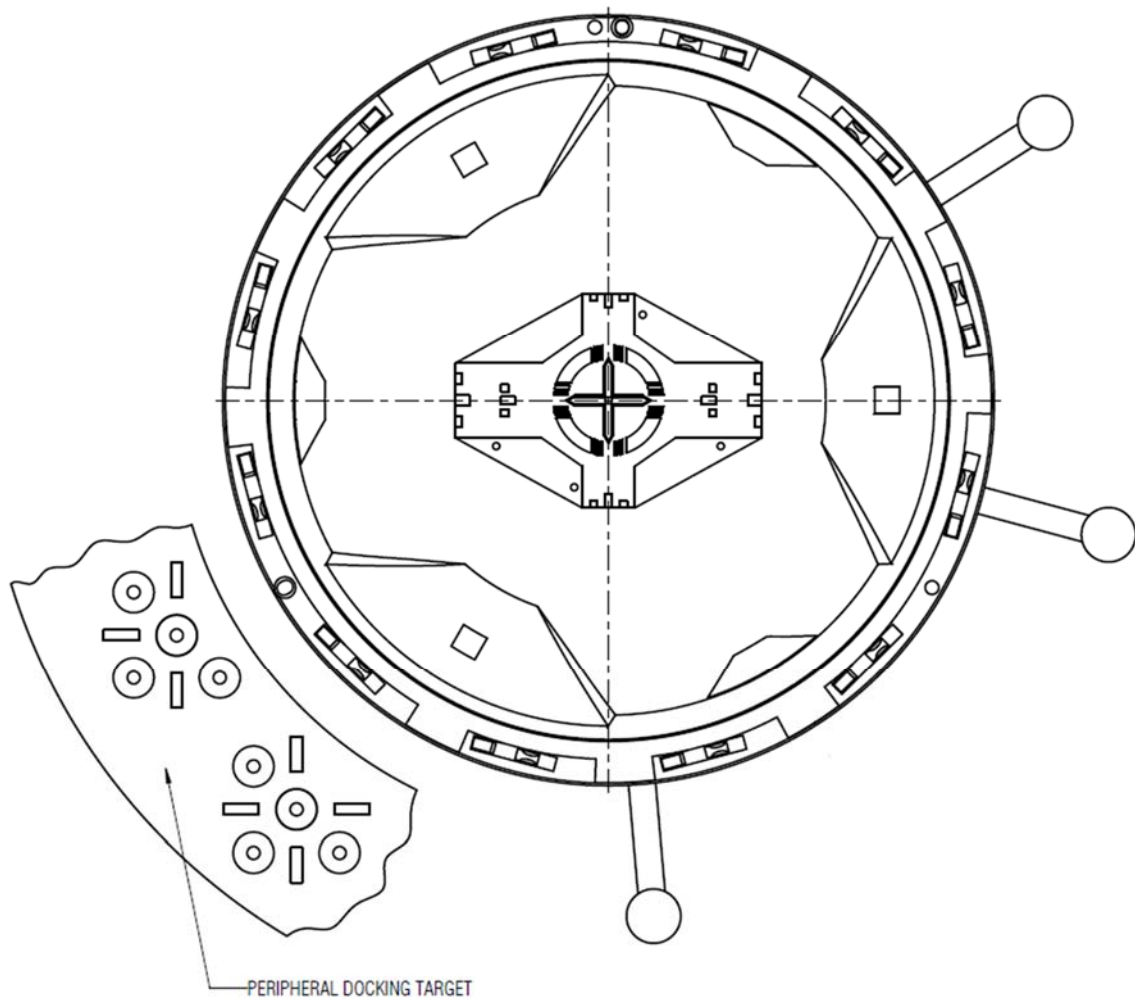

Figure 1. Docking Adapter with Peripheral Docking Target

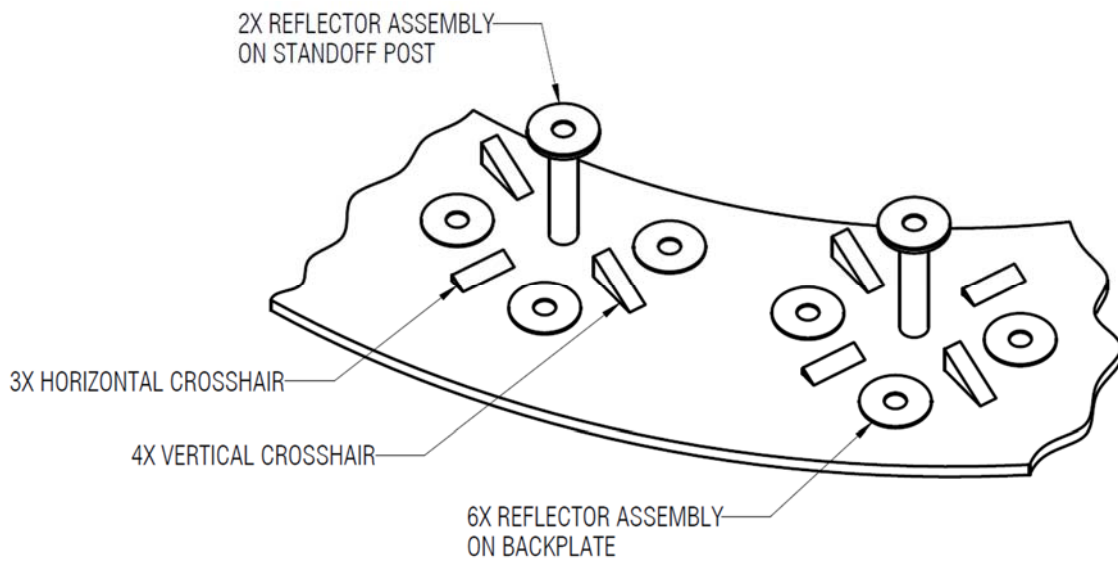

Figure 2. Peripheral Docking Target

requirement imposed overall size and weight constraints to permit the PDT to fit within allowable payload volume of the launch vehicle. Second, since the IDA design was mature by the time the PDT design effort began, the PDT was designed to require no power. Third, the PDT was designed to provide fiducials compatible with the main three relative navigation sensor types currently in use: visible light cameras, thermal imagers, and Light Detection and Ranging (LIDAR) sensors. Finally, the PDT's purpose was to allow either a navigation algorithm or a crew member to assess the alignment of the incoming vehicle with respect to the IDA's interface plane.

In order to design the markings on the backplate, the design team performed an analysis of how many individual errors in reading a peripherally-mounted docking target contribute to an accumulated error at the docking interface. This is an integrated problem that requires including the control system errors of each vehicle. However, since the rendezvousing vehicle has not been determined, some assumptions were made about the capability of the attitude control system based on experience with other spacecraft. A stackup of the errors (Figure 3) revealed that with these assumptions about attitude control capability, there is not enough error allowed to the reading of the docking target to allow a human observer to judge alignment within the 4.2 inch lateral misalignment limit specified in the International Docking System Standard. Thus, the design team made the decision

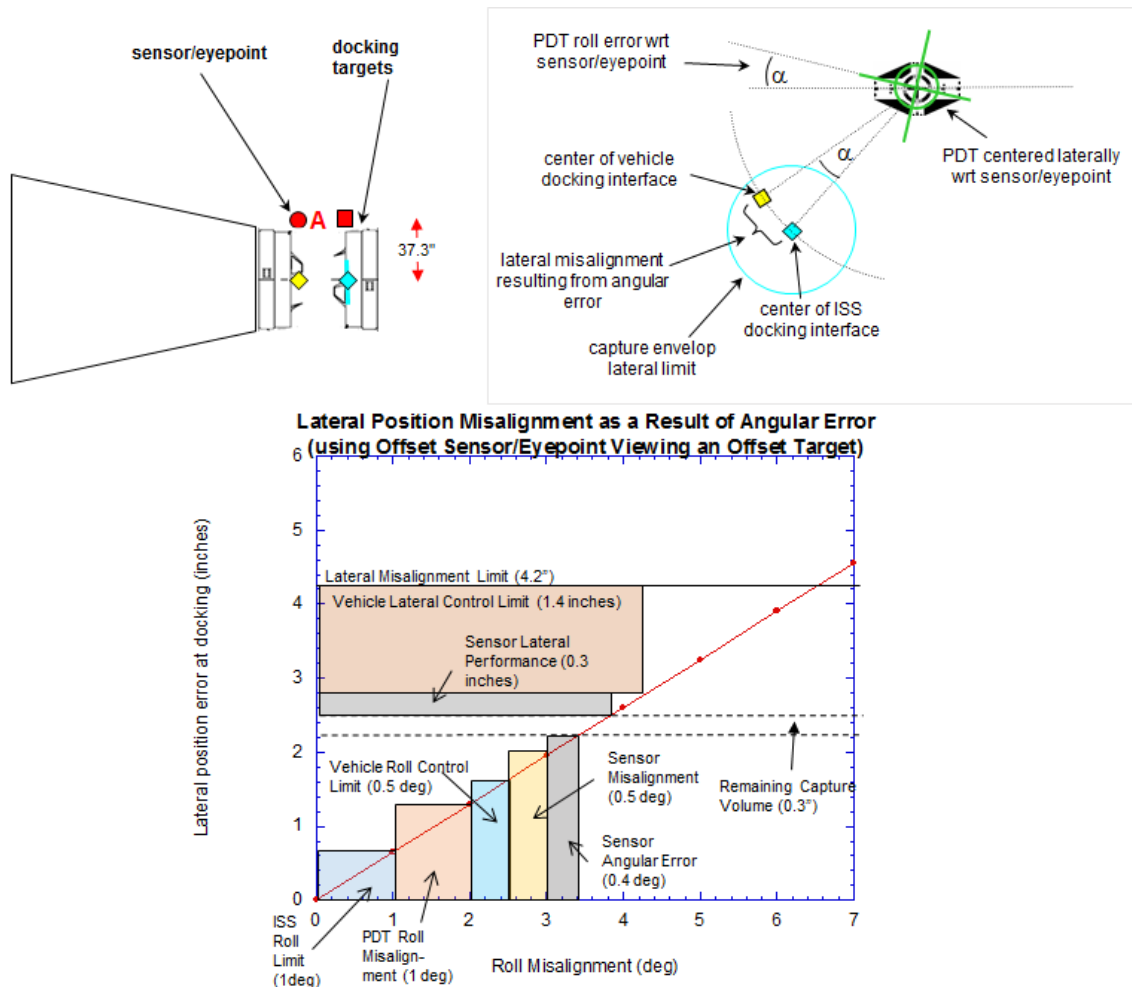

Figure 3. Lateral Misalignment Resulting from Peripheral Docking Target

to specifically not include markings on the PDT that would enable human crew to align for a manual docking, but markings would be included to allow a human crew to monitor the alignment. The markings do not indicate an envelope within which the alignment is considered adequate, but the center point is indicated by a set of crosshairs on the backplate, and the crew can assess the deviation from center in any direction.

The PDT provides two redundant targets, with each target providing three fiducials (such as depicted in Figure 4) on a backplate plane, and one fiducial on a standoff post. Having a fiducial on a standoff makes it easier for an automated system to determine and a human to monitor the misalignment with respect to the PDT. Because of the desire for the PDT to be compatible with multiple sensor technologies, the fiducials were designed to be usable by multiple technologies. The fiducials include prismatic reflective tape in the center, surrounded by a circle that is designed to contrast with the backplate in both the visible and thermal radiation bands.

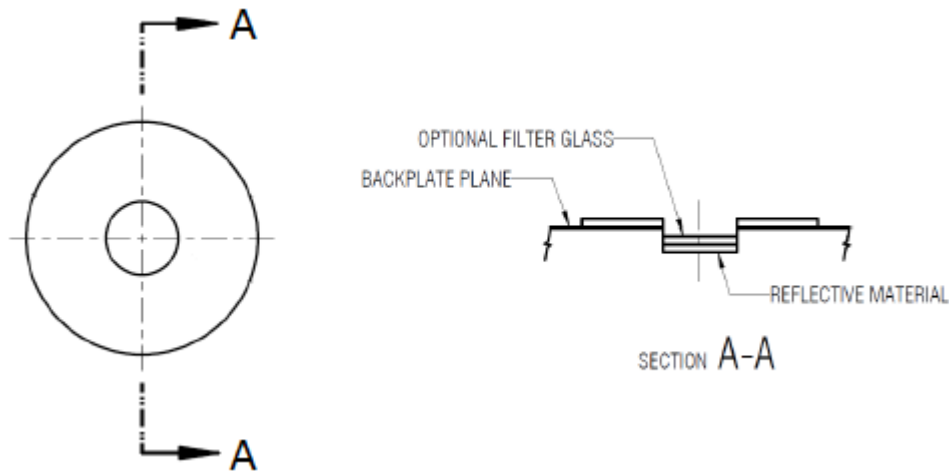

Figure 4. Fiducial Details

In researching the principles of thermal imaging, the IDA Docking Targets team found that thermal emissivity is what determines the contrast visible to thermal imagers, and that surface finish (not the underlying material) is what makes a difference in emissivity values. According to Kirchoff’s Law of thermal radiation, the radiation absorbed by an object equals the radiation emitted by that object.

$$\alpha_{\lambda} = \varepsilon_{\lambda}$$

According to the conservation of energy, the fraction of radiation incident on the object is the sum of the reflected energy, the transmitted energy, and the absorbed energy.

$$\Phi_0 = \Phi_R + \Phi_T + \Phi_A$$

For an opaque item, there is no energy transmitted. Combining conservation of energy with Kirchoff’s Law, we obtain:

$$\varepsilon = 1 - R$$

In other words, the less emissive a material is, the more reflective it is. Thus, in the design goal to provide contrast for a thermal imager, any low emissivity features must be designed with the consideration that thermal energy from the environment, the ISS, or the active rendezvous vehicle will be reflected in the thermal image.

To reduce the chance of thermal reflections of the active rendezvous vehicle, the crosshairs are angled to reflect the thermal sink of deep space. However, the same angling could not be done with the circular fiducials because any “tunnel” formed by the angling would reduce the visible diameter of the reflective tape at the center. The design team tested two options: a flat circle, and a circle that had a peaked cross-section.

The team evaluated several different surface finishes using two different prototypes of the peripheral docking target: one with a white backplate and dark features, and one with a dark backplate and light features. In both of the targets, all of the material was aluminum with different surface coatings. In both, the circular navigation features had an outer diameter of 3 inches and an inner diameter of ~1”. The crosshairs were 2 inches long by 0.5 inches wide.

The white backplate was coated with AZ Technologies’ AZ-93 thermal paint, selected for its white color and high emissivity. The circular navigation features were coated by AnoPlate with their AnoBlack Cr (aka “black chrome”) coating. The crosshairs were coated with a chemical film. The reflective elements (for LIDAR compatibility) were made of 3M 3000X reflective tape sitting under a Schott GG-395 1” diameter X 3 mm thick circular glass filter (nominally clear in color).

The black backplate was given a black anodized coating. Each of the crosshairs and two of the circular navigation features were made of mechanically polished aluminum. One of the backplate circles was made of unfished aluminum. To give the final backplate circle a different finish, the team took an 16 microinch finish aluminum circle and roughed it up using a coarse grit sandpaper. The reflective elements (for LIDAR compatibility) were made of 3M 3000X reflective tape sitting under a Schott RG-1000 1” diameter X 3 mm thick circular glass filter (nominally black in color).

TEST METHODOLOGY

To test the prototypes’ performance with a visual camera, the targets were tested in the Electro Optics Laboratory at NASA’s Johnson Space Center. The targets were set up one at a time at one end of the tunnel-like facility. The targets were illuminated using a Litepanels 1’x1’ Daylight Flood LED Panel, and pictures were taken using a Nikon CoolPix S800 (14.2 Mpixel [4320x3240], Focal length 3.5-5.6 and digital zoom up to 2x) mounted on a tripod such that the camera was aligned with the standoff post of the target. Photographs were taken at 1 meter, 5 meters, 10 meters, and ~15 meters range. To assess the effects of placement of the spacecraft lights, at each range position, the LED panel was placed in five positions with respect to the camera as shown in Figure 5. At 1 meter range, the LED panel was also canted towards the target at each of the 5 lighting positions to assess the stressing case of light placement causing a washout of the features in the visible camera.

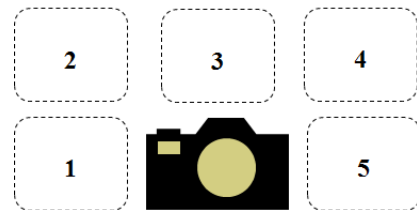

Figure 5: Lighting Positions for Visual Contrast Tests (as seen from behind the camera)

To test the prototypes’ performance with a thermal imager, the target concept required the low-emissivity features to have a thermal sink to reflect to the thermal imager to provide contrast. The team found that a clear sky served as a very good thermal sink for use during the test. The tests of the prototypes with the thermal imager were performed outdoors at NASA Johnson Space Center. The team performed tests with the targets in the shade and after soaking for an amount of time in the sun to assess whether either case would present problems in discerning the thermal contrast. The approximate ambient temperature at the time of the test was 65°F. The portion of the test performed in the sun was done in the early afternoon (1:26-1:53pm) in the winter (January 22, 2014). The prototypes were allowed to soak in the sun for 10 minutes before any test images were

taken. One at a time, each prototype was mounted such that it was facing the sun. Thermal imaging of each target took about 10 minutes. Thermal images were taken with a FLIR E60 thermal imager set on a tripod such that it was aligned with the standoff post of the target, and images were taken at 1, 5, 10, and 15 meters from the target.

Further testing was performed to refine the thermal contrast requirement between the backplate and the features. Five different black materials were placed on the white backplate: two samples of Anoplate black chrome, and one sample each of Anoplate Black NiTE, Anoplate black nickel, and a Neptec black Inconel interference stack. The measured emittance of the samples are recorded in Table 1. Thermal imagery was taken, both in the shade and after a 20-minute soak in the sunlight.

Table 1: Measured Emittance and Solar Absorptance of the Candidate Black Materials

Material	Emittance	Solar Absorptance
Black Chrome (January 2013)	0.64	0.94
Black Chrome (July 2013)	0.74	0.95
Black Inconel	0.49	0.96
Black Nickel	0.52	0.79
Black NiTE	0.66	0.90

To test the prototypes' performance with a LIDAR, both prototypes were sent to Ball Aerospace's facility in Boulder, Colorado to test with their Vision Navigation System (VNS) sensor. This test provided the opportunity to test the effects of several variations in the target design. First, the effect of performing a thermal-vacuum bakeout of the reflective tape was tested. The black prototype was outfitted with unbaked, out-of-the-box tape, and the white prototype was outfitted with tape that had been baked at 210°F, 1×10^{-3} torr, for three hours. Second, the effect of different glass filters on the LIDAR return was tested. Each prototype was outfitted with Schott GG395 clear glass, NG11 neutral density filtered glass, OG515 orange glass, and RG1000 black glass. With these setups, the effect of the filters could be assessed by comparing the lidar returns on each backplate, and the effect of the reflective tape bakeout could be assessed by comparing one backplate to the other.

TEST RESULTS

At different ranges, a navigation system performing feature recognition will be focusing on different parts of the Peripheral Docking Target. Inside of around 5 meters, the features of interest would likely be the inner circle. Thus the contrast of interest would be the contrast between the glass filter and the circular navigation feature. Outside of 5 meters, the features of interest would likely be the outer circle. Thus the contrast of interest would be the contrast between the circular navigation feature and the backplate. The use of the crosshairs (whether by a system performing feature recognition or by a crew member monitoring the alignment) is not range dependent.

The images captured during testing were evaluated according to the following criteria:

- Visible contrast between backplate and circles/crosshairs
- Visible contrast between circles and filtered glass
- Thermal contrast between backplate and circles/crosshairs
- Thermal contrast between circles and filtered glass

In addition, the images from the visible light tests were checked for any effects that may cause problems for feature recognition, such as glinting, glare, or washout.

Visible Light

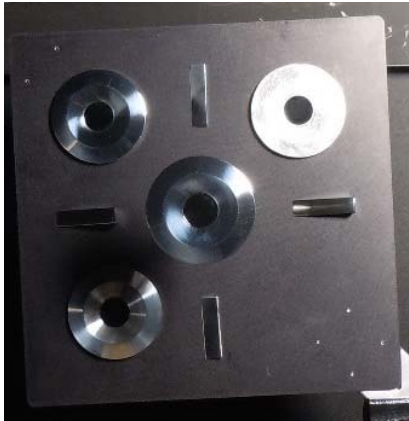

**Figure 6: Black Backplate at 1m
(Light to the upper right)**

Figures 6 and 7 show the images that have the best contrast for each prototype design. Figure 6 shows that of the finishes tested, the circle had been sanded (upper right) provided the most uniform return. The polished aluminum (upper left and center) and the smooth finish (lower left) not only have the ability to reflect glint from the light source more intensely, but also



**Figure 7: White Backplate at 1m
(Light to the upper left)**

reflect the dark areas of the room, reducing the apparent contrast with the backplate. Both glinting and loss of contrast can cause problems for feature recognition software. On the other hand, Figure 7 shows that the white paint and the black chrome are all relatively low gloss, with less susceptibility to the lighting environment.



**Figure 8: Black Backplate at 5m
(Light to the upper right)**

Figures 8 and 9 show the images that have the worst contrast for each prototype design. The black backplate prototype has several problems in producing adequate contrast for feature recognition. The most problematic is that surface reflection can occur off of the black filtered glass, making it appear white. This color inversion is dependent only on lighting geometry (and not on the intensity of the lighting environment) and hinders the targets usability right up until docking, when the relative alignment is most crucial. In addition, the black anodized backplate can reflect glare from the lights, washing it out and making it appear white. In addition, the aluminum features can reflect glint from the lights, causing intensity peaks that could fool a feature recognition algorithm. Figure 9 highlights some of the problems the white backplate prototype has in certain lighting geometries. First, the 3000X reflective tape can bloom when the light source and camera are configured at the right angle. The white color of the backplate is susceptible to glare that can wash out the black chrome features. Also, the black chrome features themselves are not perfectly flat finish, and can reflect

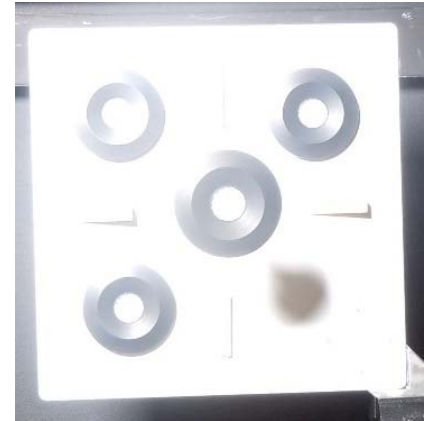

**Figure 9: White Backplate at
1m (Light to the upper left and
canted towards the target)**

dependent only on lighting geometry (and not on the intensity of the lighting environment) and hinders the targets usability right up until docking, when the relative alignment is most crucial. In addition, the black anodized backplate can reflect glare from the lights, washing it out and making it appear white. In addition, the aluminum features can reflect glint from the lights, causing intensity peaks that could fool a feature recognition algorithm. Figure 9 highlights some of the problems the white backplate prototype has in certain lighting geometries. First, the 3000X reflective tape can bloom when the light source and camera are configured at the right angle. The white color of the backplate is susceptible to glare that can wash out the black chrome features. Also, the black chrome features themselves are not perfectly flat finish, and can reflect

light making their color appear less black. However, the worst contrast the white prototype can offer is better than the worst the black prototype offers. Even though there is reduced contrast in Figure 9, even the faintest black chrome feature is still visible to some extent, allowing a feature recognition to extract some signal out of the glare.

Thermal Imaging

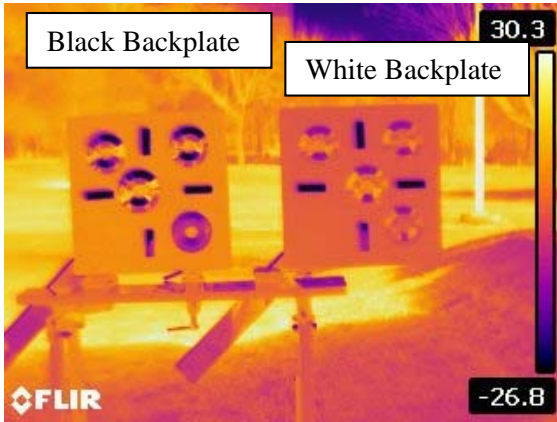

Figure 10: Black and White Backplate Targets at 2.5m in the shade

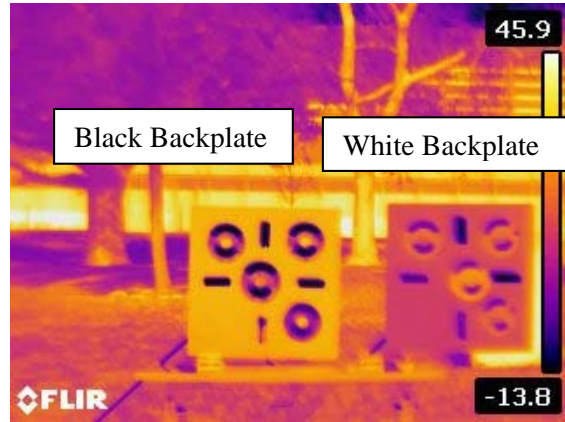

Figure 11: Black and White Backplate Targets at 2.5m in the sun

Figures 10 and 11 show side-by-side comparisons of the white and black backplate prototypes. At this range, a feature recognition could use either the contrast between the outer circles and the inner circles, or the contrast between the outer circles and the backplate. Figure 10 shows that in the shade, reflected heat from the environment has a more pronounced effect on the contrast due to the cooler temperature of the thermally emissive backplate. Both backplates show that, except for the sanded aluminum circle, the circle features do not produce a very uniform return, but there are arcs that reflect the cold temperature. Contrast between the circles and the backplate does not appear to be a problem, but contrast between the circles and the glass at the center of each is more difficult to discern. Overall, the thermal contrast of the black backplate performs better than the white backplate. The black backplate has sharp contrast between the backplate and the circles, and enough contrast between the glass and the circles that the size of the glass can be discerned. The white backplate provides enough contrast that the circles can be differentiated from the backplate, but the size of the glass circles cannot be clearly discerned. Figure 11 shows that in the sun, the contrast between the backplate and the features is more pronounced, and thus the relative effect of the thermal reflection from the environment is reduced. Yet even in the sun, the circles do not produce a uniform return. However, the dark parts of the circles (that are reflecting the sky's thermally cold signature) are crisper. Consequently, the glass circles on the white backplate prototype, which were very difficult to discern in the shade, are much easier to discern in the sun. Just as in the shade, the black backplate prototype provides better contrast than the white backplate.

Materials Study for Thermal Imaging

Figures 12 and 13 show thermal images taken to compare the thermal contrast between the backplate painted with AZ-93 paint and various samples of black materials under consideration for the black features. In both pictures, the materials are as follows:

- A- Anoplate black chrome, manufactured January 2014
- B- Anoplate black chrome, manufactured July 2014
- C- Neptec black Inconel interference stack

- D- Anoplate Black NiTE
- E- Anoplate black nickel

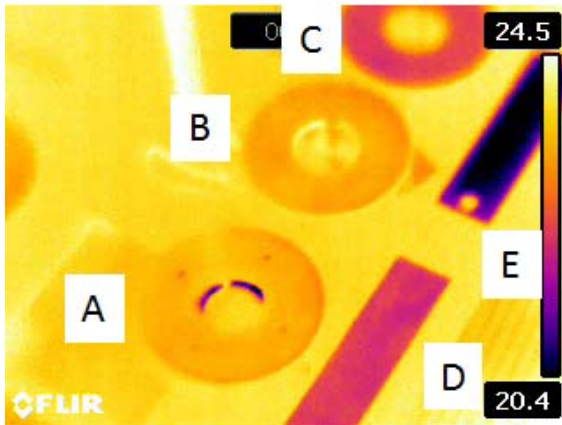

Figure 12: Comparison of the Thermal Contrast between AZ-93 Paint and Various Black Materials in the Shade

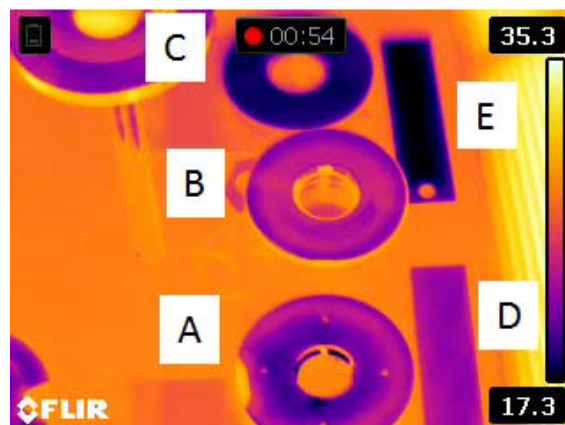

Figure 13: Comparison of the Thermal Contrast between AZ-93 Paint and Various Black Materials in the Sun

The team identified that the worst case for thermal contrast is where the backplate has not had a chance to be warmed by the sun. Figure 12 shows the results when the prototype was brought straight from inside to the shade. Samples C, D, and E show some more pronounced reflection of the sky than samples A and B. These results were consistent with the expectation based on the measured emittance of the materials in Table 1. It is difficult to clearly discern the edge of samples A and B, especially given the small temperature range in the image as shown by the bar on the right side of the image.

Figure 13 shows the same test setup after it had been allowed to soak in sunlight for 20 minutes. Because the backplate has had a chance to rise in temperature, the contrast between the backplate and the black features is greater. While it is easy to discern the edge of all five of the samples, the contrast is greatest for samples C and E.

LIDAR Test

Figures 14-16 shows the results of the testing with the Vision Navigation System (VNS) at 3 meters, 5 meters, and 10 meters, respectively. In these boxplots, the bold line in the box represents the median, the bottom and top of the box indicate the first and third quartile, respectively. The ends of the whiskers represent the point nearest the median that falls within 1.5x the width of the box, and any points outside the whiskers are represented as individual dots. The upper and lower case letters correspond to the glass filters as follows:

- A – clear GG395 glass
- B – gray NG11 glass
- C – orange OG515 glass
- D – black RG1000 glass

One of the more surprising results was that the black anodized backplate provided more LIDAR return than the white painted backplate, including enough return that at 5 meters or less, that more than half of the intensity measurements exceed the discard threshold. Unwanted returns from the backplate can result in degraded performance of a centroiding algorithm.

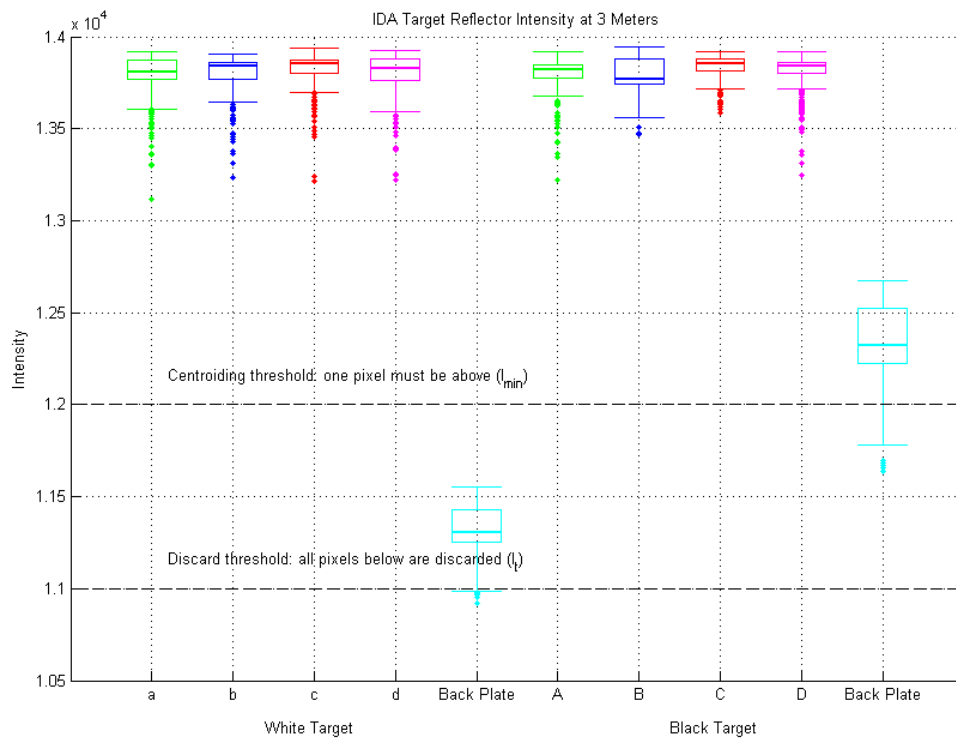

Figure 14: LIDAR Intensity Return of the PDT Prototypes at 3 Meters Range

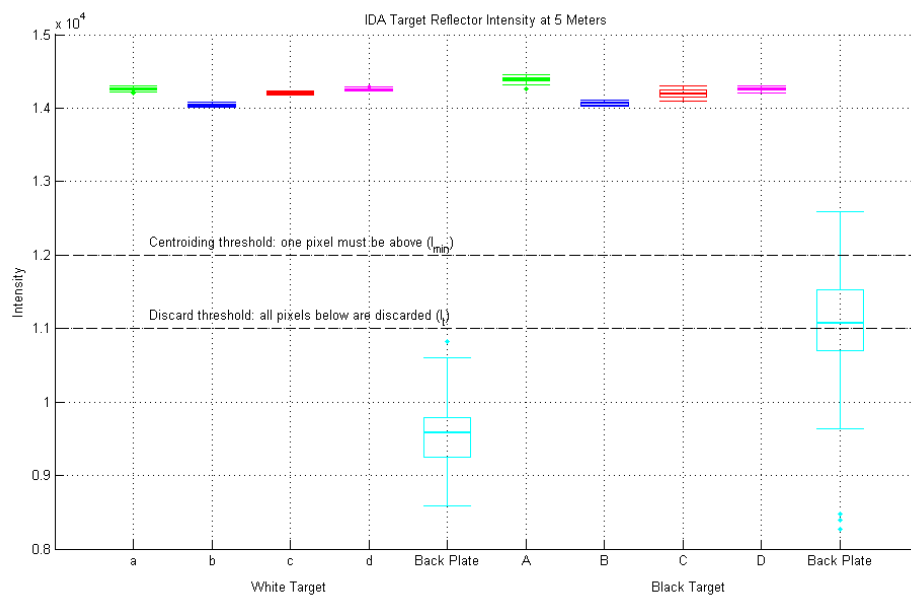

Figure 15: LIDAR Intensity Return of the PDT Prototypes at 5 Meters Range

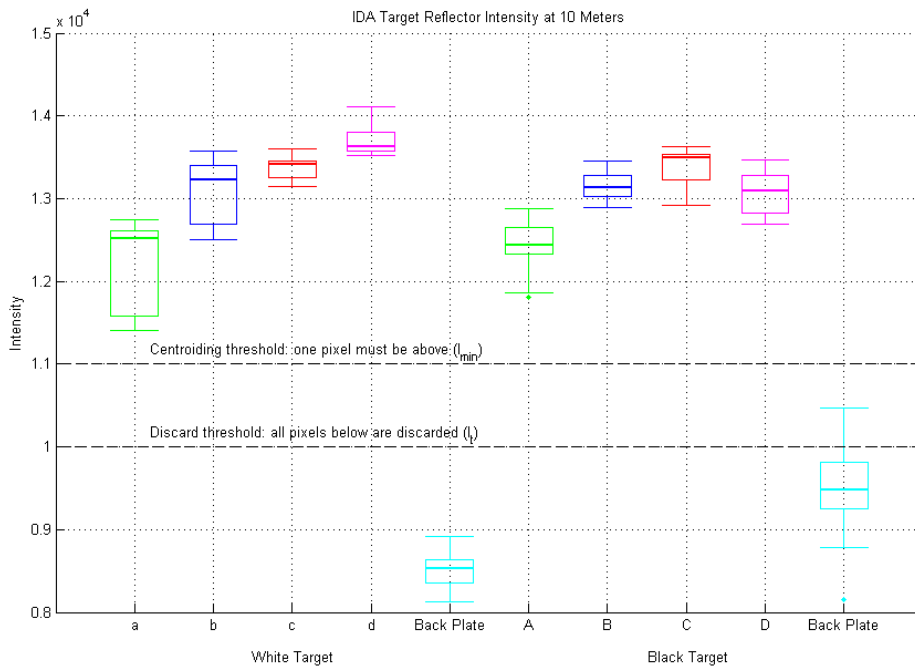

Figure 16: LIDAR Intensity Return of the PDT Prototypes at 10 Meters Range

The second result of note is that the thermal-vacuum “bakeout” of the reflective tape does not appear to have any effect on the intensity return. At all three ranges, the intensity return for the reflectors on the white backplate (baked) is about the same as the return from those on the black backplate (not baked).

The final result is that there is a minor effect of the filtered glass on the intensity return, but that while the effect is consistent from one backplate to the next, it is inconsistent with respect to range. Figure 14 shows that there is no discernable effect of the glass filtering at 3 meters. Figure 15 shows that the NG11 filter results in the lowest intensity return at 5 meters, as would be expected. But Figure 16 shows that the GG395 filter results in the lowest intensity return at 10 meters. It is not known why the results vary with range, or what experiment setup effects may be contributing to these results. But the useful result that can be gleaned is that all of the tested filters result in sufficient LIDAR return to perform relative navigation.

CONCLUSION

The biggest lesson gleaned from this testing effort was that it was very difficult to emulate the flight-like environment for testing the thermal imager. In space, the primary sources of emitted or reflected thermal energy are the sun, earth, ISS, and visiting vehicle. While qualitative conclusions about the quality of the reflectivity could be drawn, determining what the flight-like returned thermal image may look like was impossible in the test environments used for this effort.

In combining thermal and visible contrast across several lighting conditions, the best of the tested material combinations was the white backplate (painted with AZ Technologies’ AZ-93 thermal control paint) and black features (coated with Anoplate’s Anoblack Cr black chrome) and clear filtered glass (Schott GG-395). The black backplate prototype provided excellent thermal contrast, but the shininess of the aluminum features and the surface reflection from the filtered black glass made it an undesirable candidate for a multi-use docking target. The IDA Docking Targets team

recommends a combination of white, high-emissivity and black, low-emissivity features for the design of a dual-use visible camera and thermal imager docking target.

ACKNOWLEDGMENTS

The PDT team wishes to thank Rebecca Johanning and Shane Robinson for coordinating, performing, and analyzing the testing of the PDT prototypes with the VNS, and Thang Le and his team for producing the drawings in this document.

REFERENCES

1. Gilmore, David G. *Spacecraft Thermal Control Handbook Volume 1: Fundamental Technologies*. The Aerospace Press. El Segundo, CA. 2002.
2. Vollmer, Michael; and Möllmann, Klaus-Peter. *Infrared Thermal Imaging: Fundamentals, Research and Applications*. Wiley-VCH. Weinheim, Germany. 2010.