

Agenda – Day 1



November 18, 2014 (Day 1)		
Time (CST)	Topic	Presenter
8:00-8:30 am	Registration, Welcome and Introductions	
8:30 – 9:15 am	History & Manufacture of EDU	Arthur Werkheiser
9:15 – 10:00 am	Multi-Layer Insulation (MLI)	Jessica Wood
10:00 – 10:15 am	BREAK	
10:15 – 11:30 am	Thermal Analysis of EDU	Tim Page
11:30 – 1:00 pm	LUNCH	
1:00 – 1:45 pm	Radio Frequency Mass Gauge (RFMG)	Greg Zimmerli
1:45 – 2:45 pm	Pressurization test results	Jonathan Stevens
2:45 – 3:15 pm	Fill model	Ali Hedyat
3:15 – 4:00 pm	Cryo Valves	Becky Crownover
4:00 – 4:20 pm	Liquid Acquisition Device (LADs)	Arthur Werkheiser
4:20 – 4:45 pm	TVS	Joe Zoeckler
4:45 – 5:00 pm	Success criteria & Wrap up	Arthur Werkheiser
	Adjourn to the Firehouse Pub	



Evolvable Cryogenics (eCryo) Project Technology Workshop with Industry

Engineering Development Unit (EDU) Workshop

Thermal Design of EDU

Tim Page



Outline

- Test Objectives
- Requirements
- Design
- Thermal Test Phases
- Thermal Test Results
- Status of Analysis With Results
- Correlation Efforts
- Future Plans



Test Objectives

- Safely load the EDU to 90% full with Liquid Hydrogen (LH2)
- Operate Cryogenic Valves to manage the cryogenic fluid to mimic payload tank lockup mode
- Evacuate TS300 chamber to vacuum conditions (1×10^{-5} Torr or greater vacuum) with LH2 loaded
- EDU Tank thermally reaches steady state conditions (- 0.5K change rate in 6hr)
- Use Thermodynamic Vent System (TVS) to control (to a specified bandwidth) pressure in tank
- Safely perform pressurization testing
- Safely perform Liquid Acquisition Device (LAD) outflow testing
- Conduct mass gauging measurements with Radio Frequency Mass Gaging Device (RFMG) and compare to liquid level information provided by temperature rake
- Measure EDU Boil off for simulated on-orbit heat load
- Data collection from above objectives



Design Requirements

- Design requirements driving the thermal aspects of EDU were derived from the anticipated test objectives and prior work when EDU was the Ground Test Article (GTA).
- While design requirements do not include any quantitative performance metrics such as maximum heat load or storage duration, there is a desire to reduce heat loads as much as possible.
- Final configuration then results from compromises between

reducing heat load vs. functionality,
 vs. manufacturing/assembly, and
 vs. access.

plus...

reducing heat load at vacuum vs. reducing heat load at ambient pressure



Thermal Design

- **Built to reduce heat loads at atmospheric pressure and vacuum conditions**
 - Foam insulation on the tank, structure, components, wetted lines, and non-wetted lines near wetted interfaces
 - Multi-Layer Insulation (MLI) on the tank, struts, structure, wetted lines, some non-wetted lines and wiring
 - MLI Covers or Caps at the top and bottom tank to cover components and access ports
 - Low emittance surface materials/coatings
 - Strut tubes made from S-glass composite
 - Thermal isolation at critical mount interfaces
- **Built to cope with liquefaction concerns during ground hold associated with LH₂ fluid and GN₂ purge**
 - Foam insulation thickness specified to keep the surface above liquefaction temperatures
 - Purge bags and localized He purges
 - Support Struts: foam could not be applied across the ball/pin mount interface nor on the composite tube
 - MLI Covers/Purge Bags

Thermal Design- Spray Foam

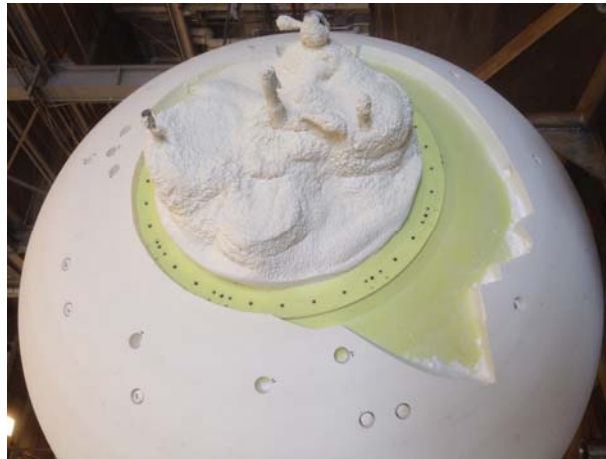

Thermal Design- Spray Foam

Components were hand sprayed prior to assembly to the extent possible.

Mount Bracket



Mount Bracket
Integrated to the Tank

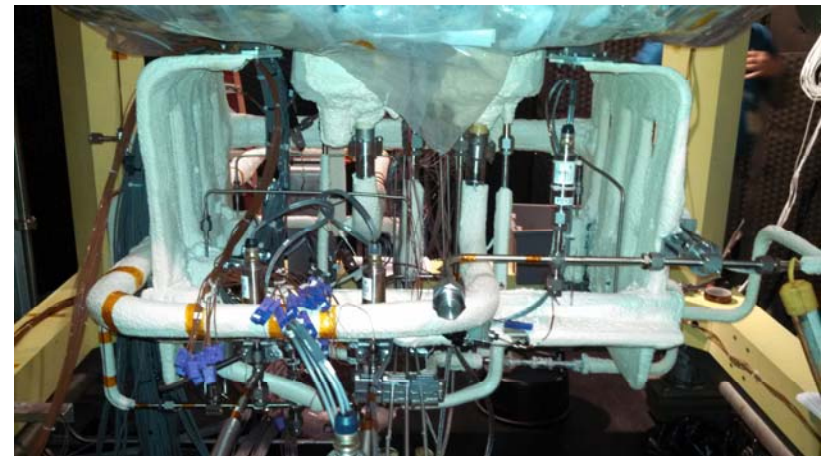

Thermal Design- Pour Foam

After final integration bare areas were masked off for closeout pour foam.

LAD Si-Diodes



Pressure Transducers



Valves



Thermal Design- Pour Foam

LAD TVS Valve Closeout



AFT Press Valve Closeout



Fill/Drain Valve Closeout



Press Line Xducer Closeout



Thermal Design- Pour Foam

L-Bracket Closeouts

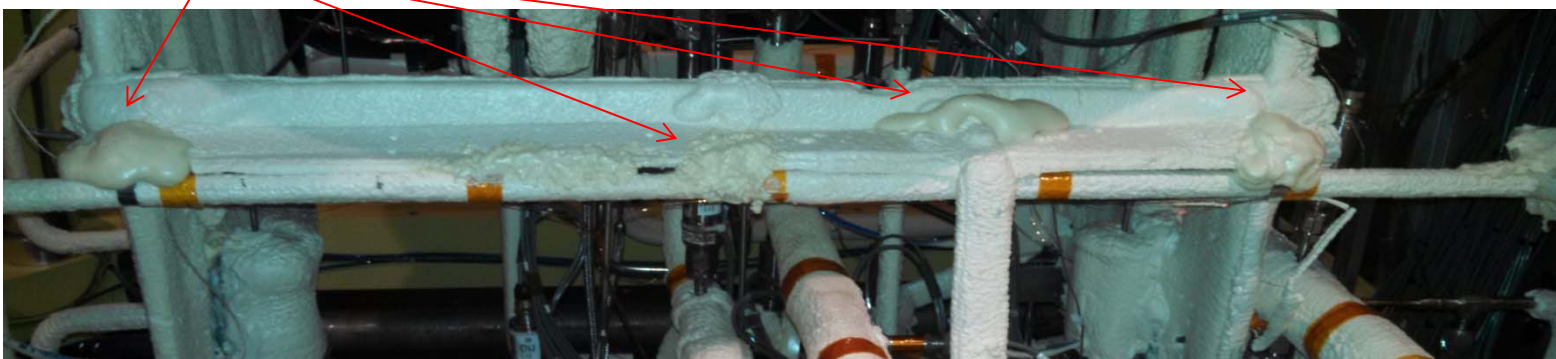

AJ TVS Inlet Closeout

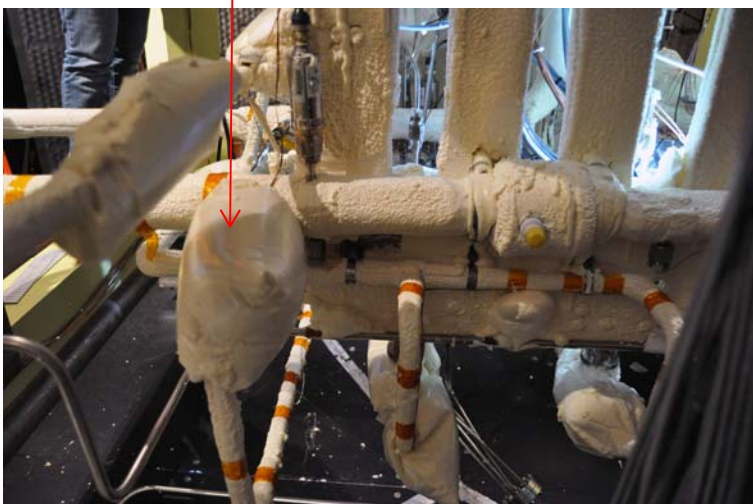

Mount Bracket & AJ TVS Pump Closeout

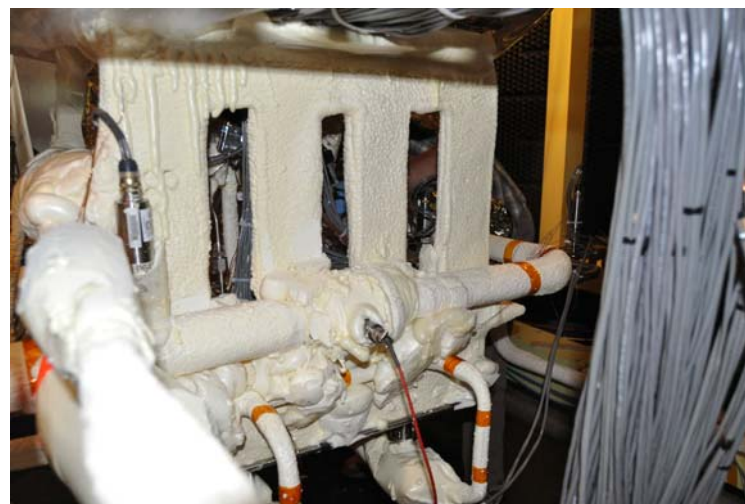

Thermal Design- Pour Foam

Back to the top of the tank...

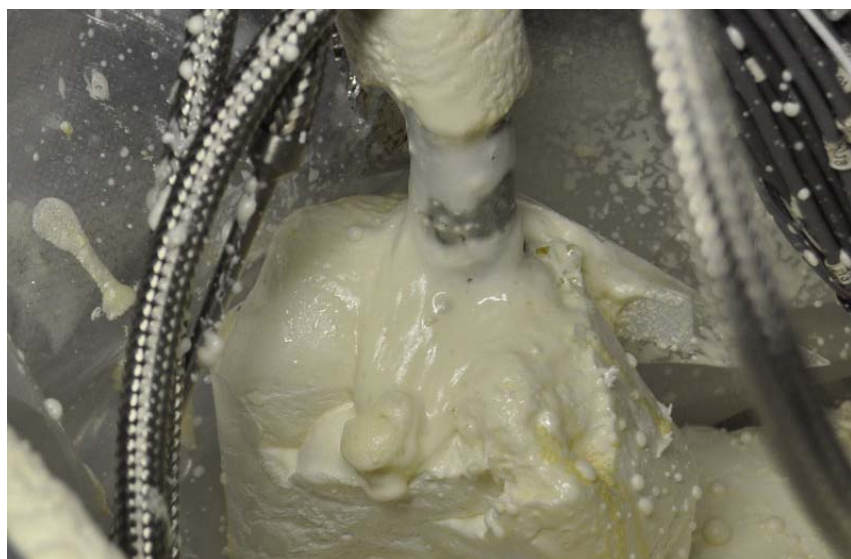

Thermal Design- Low e Wrap

Aluminized [®]Kapton wrapped over components

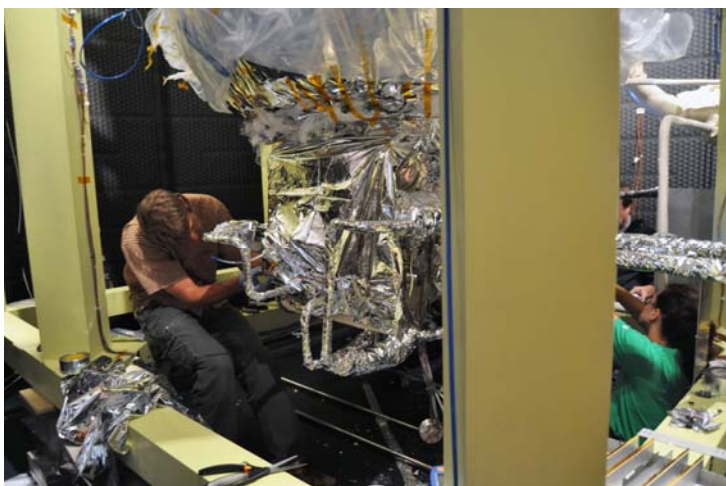
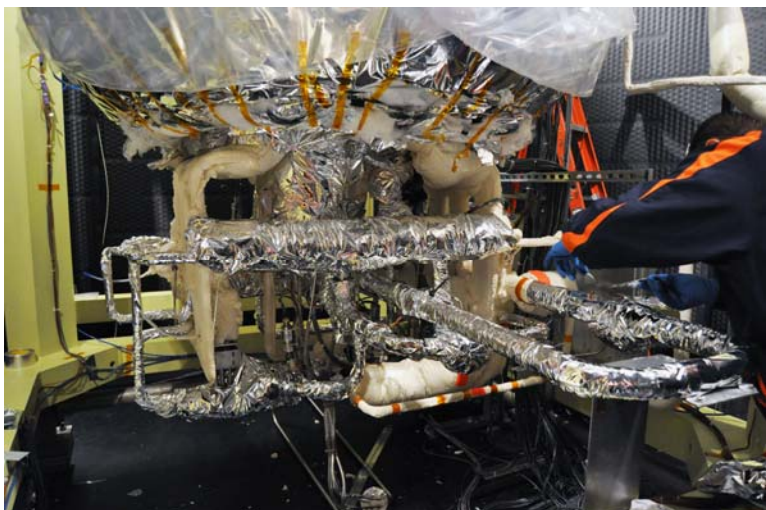

Thermal Design- Purge Bags/Final MLI

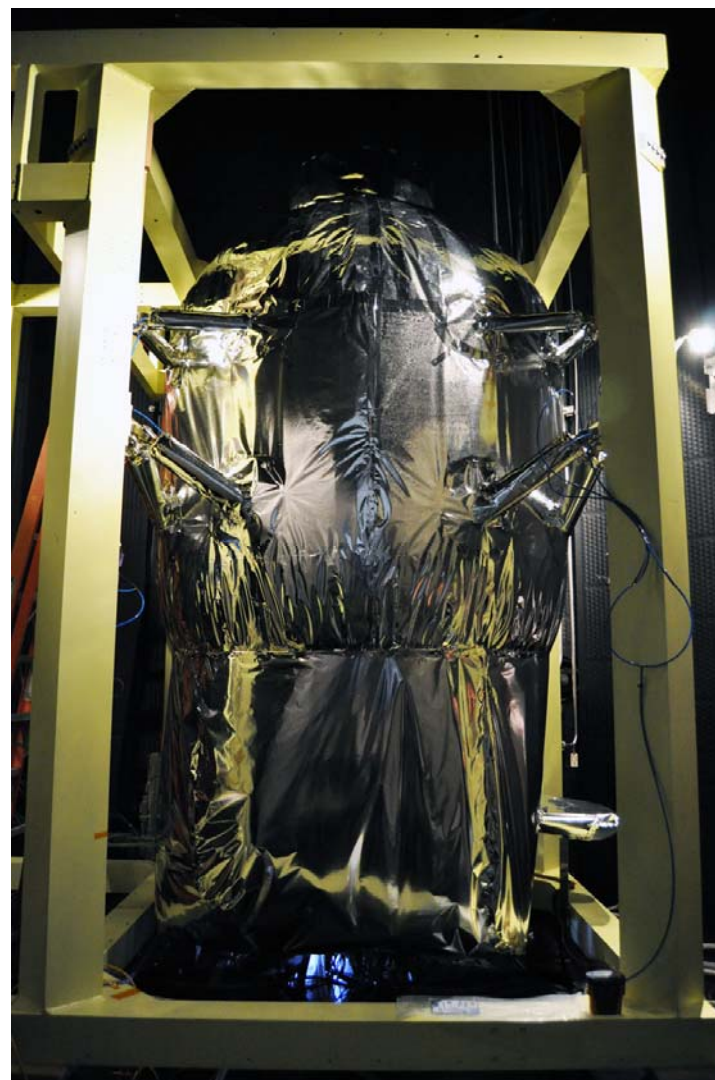

Thermal Design- Struts

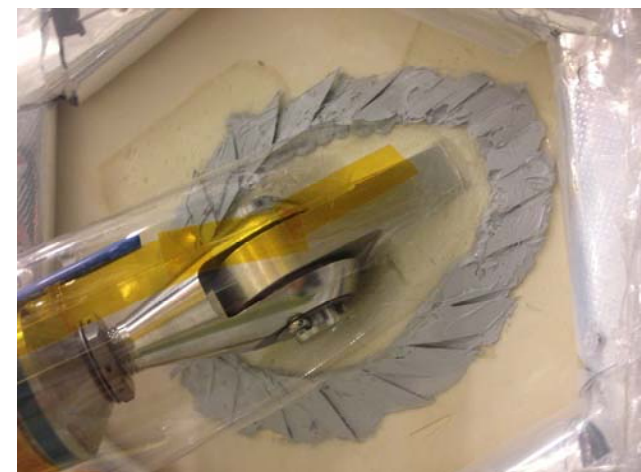
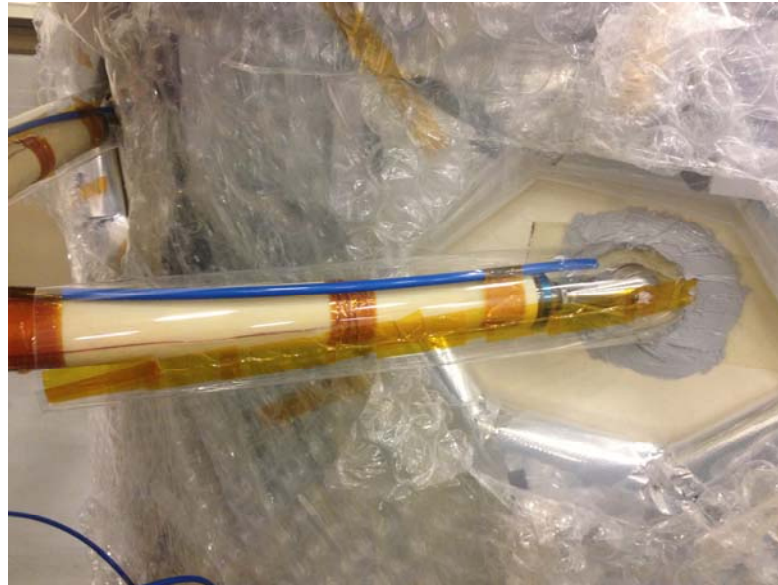

Thermal Design- Struts



Thermal Design- Struts



Thermal Design- MLI





Thermal Tests

- Ground Hold Boil-off: Transient
- Ground Hold Boil-off: Transient
- Ground Hold Pressure Rise: Transient
- Vacuum Boil-off: Steady-state
- Vacuum Pressure Rise: Transient
- Vacuum Pressure Rise: Transient
- Vacuum Boil-off: Steady-state



Thermal Tests

- Ground Hold Boil-off: Transient 06-12-14 [16:39:37 – 17:11:51]
- Ground Hold Boil-off: Transient 06-12-14 [17:52:04 – 18:11:20]
- Ground Hold Pressure Rise: Transient 06-12-14 [18:20:01 – 18:30:38]

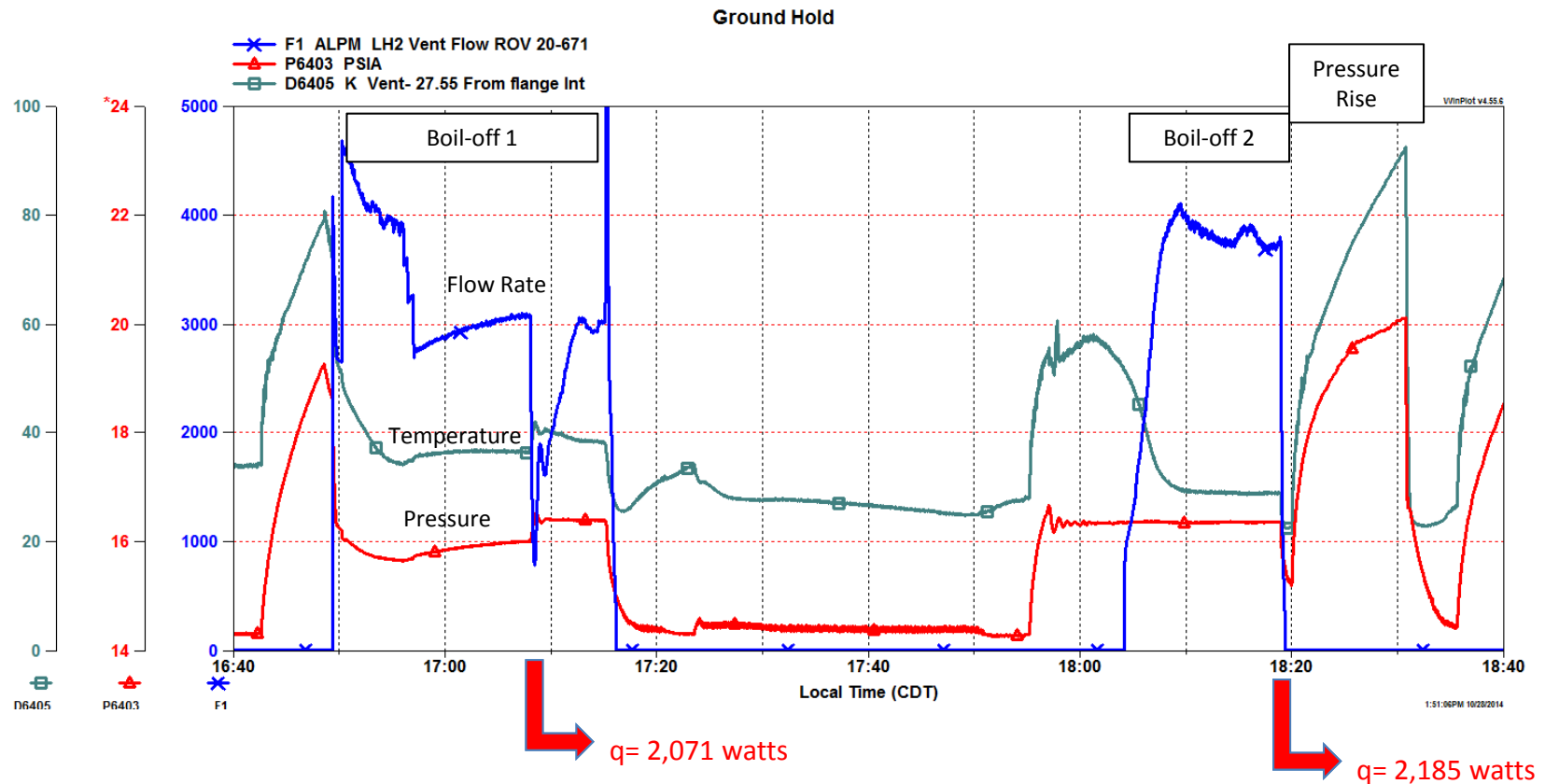



Thermal Tests

- Vacuum Boil-off 1: Steady-state 06/12/14 – 06/18/14 (06:30)
- Vacuum Boil-off 2: Steady-state 06/25/14 – 06/28/14 (12:26)

Flow rate was stable and slightly effected by the diurnal cycle

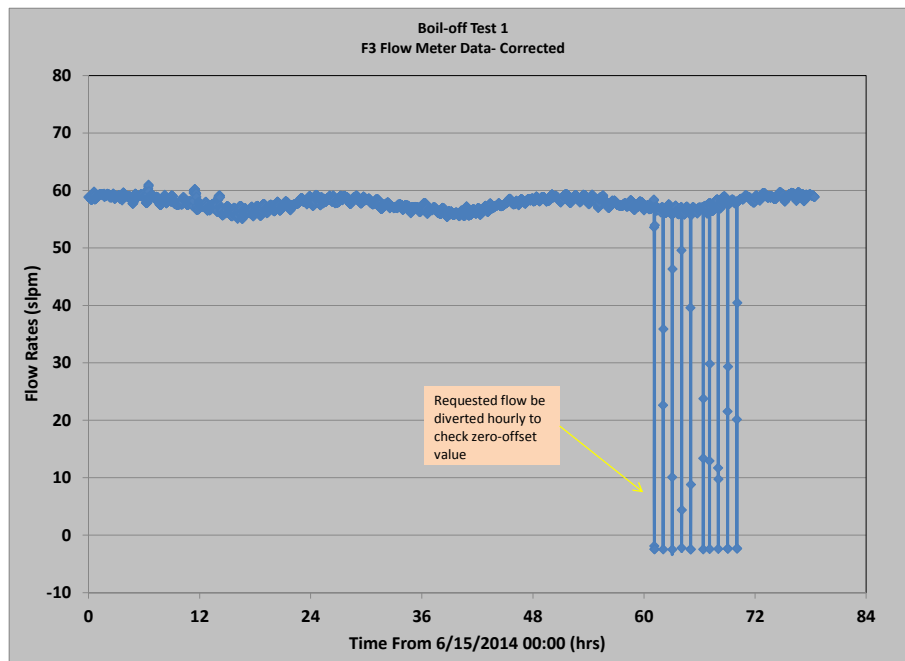

Liquid level rate of change was linear and in good agreement between measurement methods

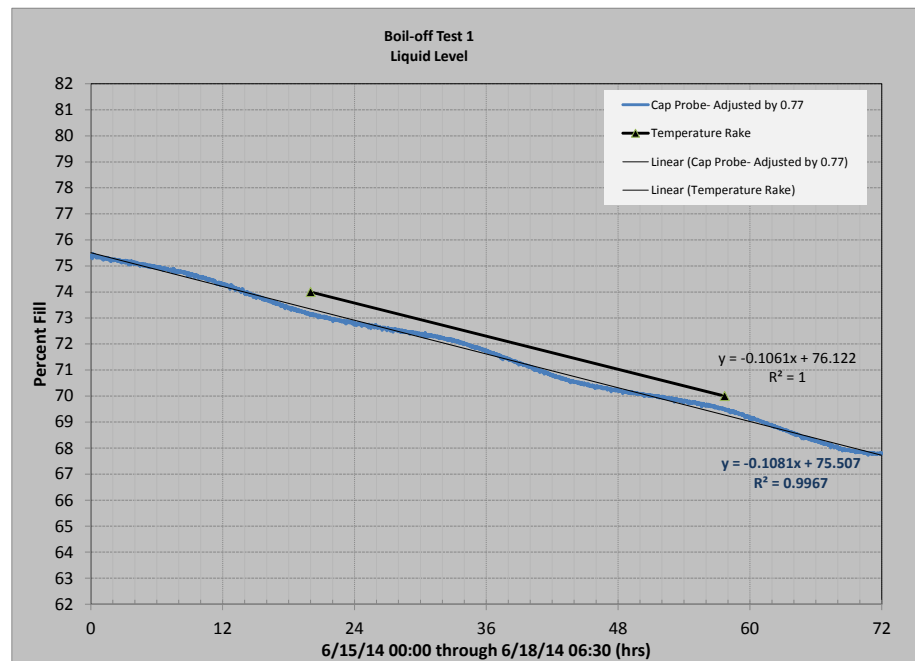



Thermal Test Results

	Boil-off Test 1	Boil-off Test 2
Day	Wednesday 6/18/14 169	Saturday 6/28/14 179
Time	06:26	12:25
Min dT/dt (K/hr)	-0.013	-0.047
Max dT/dt (K/hr)	0.196	0.117
Avg dT/dt (K/hr)	0.028	0.005
Std Dev dT/dt (K/hr)	0.033	0.025
# of sensors outside 0.08 K/hr	6 of 119	3 of 119
Cap Probe (%/hr)	-0.11	-0.12
Liquid Level (%)	~ 70	~80

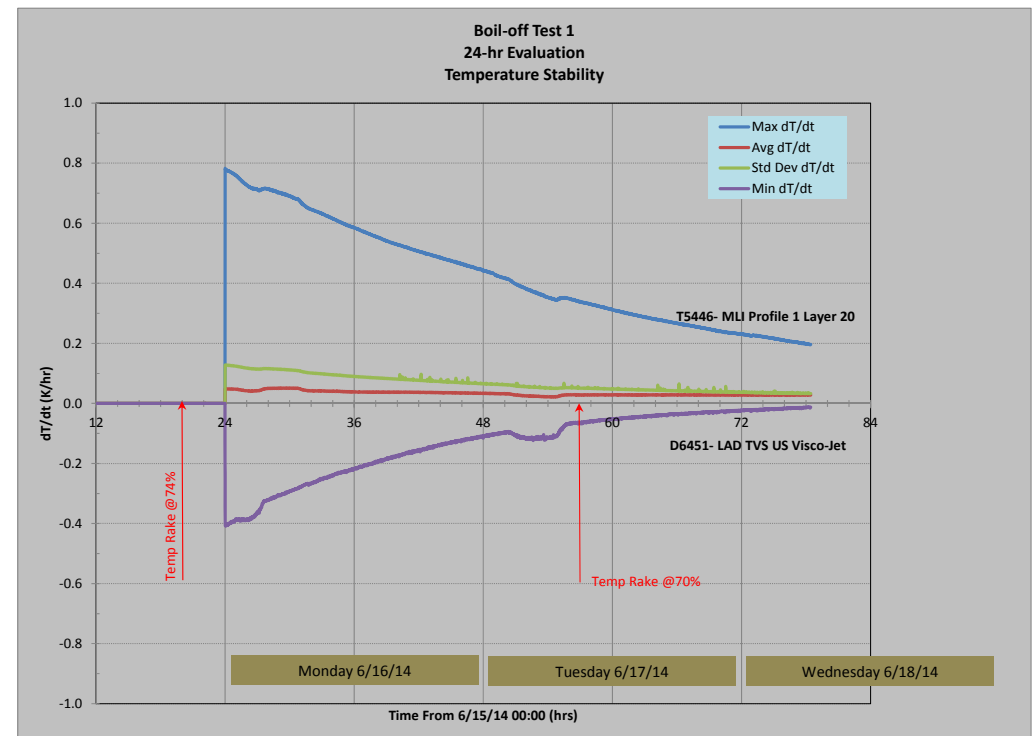



Thermal Test Results

	Boil-off Test 1	Boil-off Test 2
Day	Wednesday 6/18/14 169	Saturday 6/28/14 179
Time (CDT)	06:26	12:25
Vacuum Pressure (Torr)	1.7 E-05	1.4 E-05
F3 Flow Meter Data Total Heat Input (w) ^[1]	60	62
Cap Probe Liquid Level Data Total Heat Input (w)	59	61
Temp Rake Liquid Level Data Total Heat Input (w)	58	60
F3 Flow Meter Data Ullage/LH2 Heat Load (w) ^[1]	20/40	20/42
Cap Probe Liquid Level Data Ullage/LH2 Heat Load (w)	19/40	19/42
Temp Rake Liquid Level Data Ullage/LH2 Heat Load (w)	19/39	19/41

= > Avg +/- 1.7%

1- Value includes correction factor from post-test calibration review plus inclusion of the -2.5 slpm zero-offset.

Thermal Analysis

- Original pre-test model and analysis completed by Mark Wall
- Updated to as-built configuration
- Updated to add detail in local areas
- Some heat loads are not included (wiring & cables)

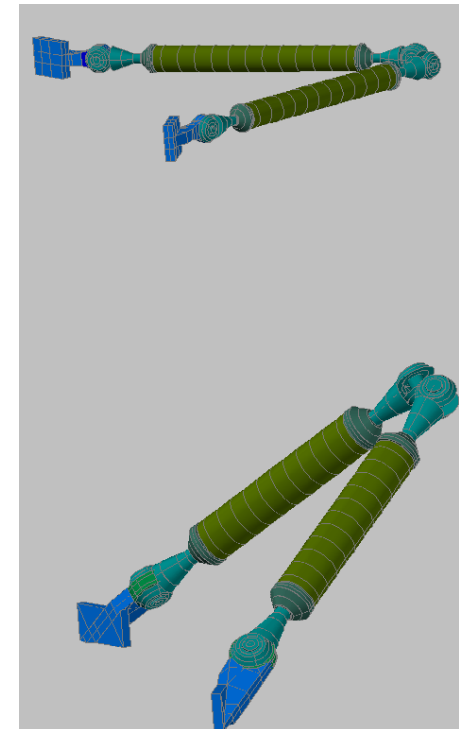
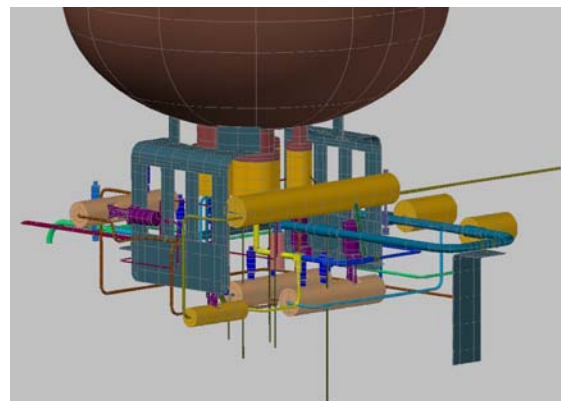
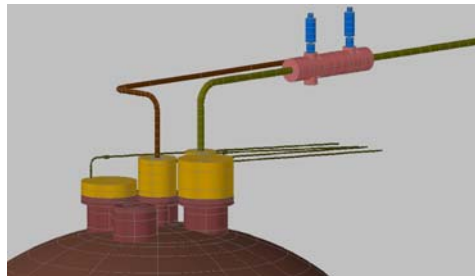
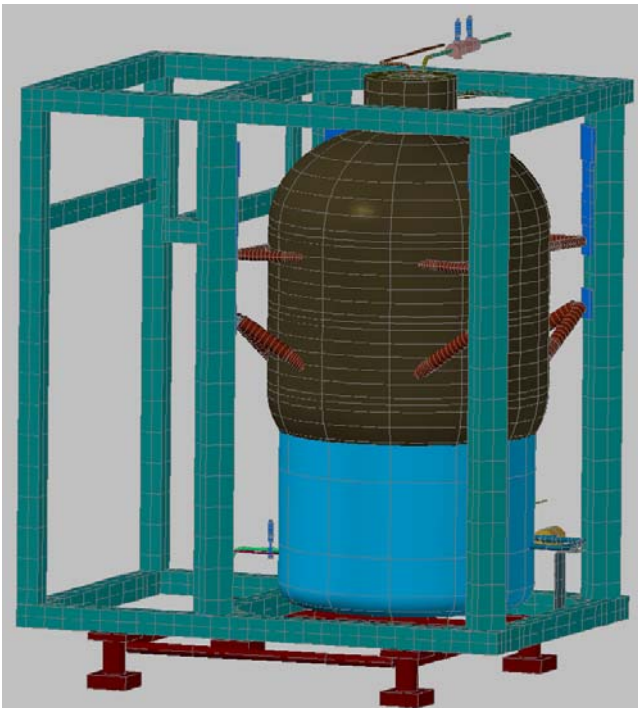



Thermal Analysis

- **Initial results Boil-off Test 1**
 - 70% fill level
 - $T_{\text{hot}} = 303 \text{ K}$
- **Key Assumptions**
 - Wetted lines remain wetted
 - MLI e^* is increased to match measured loads

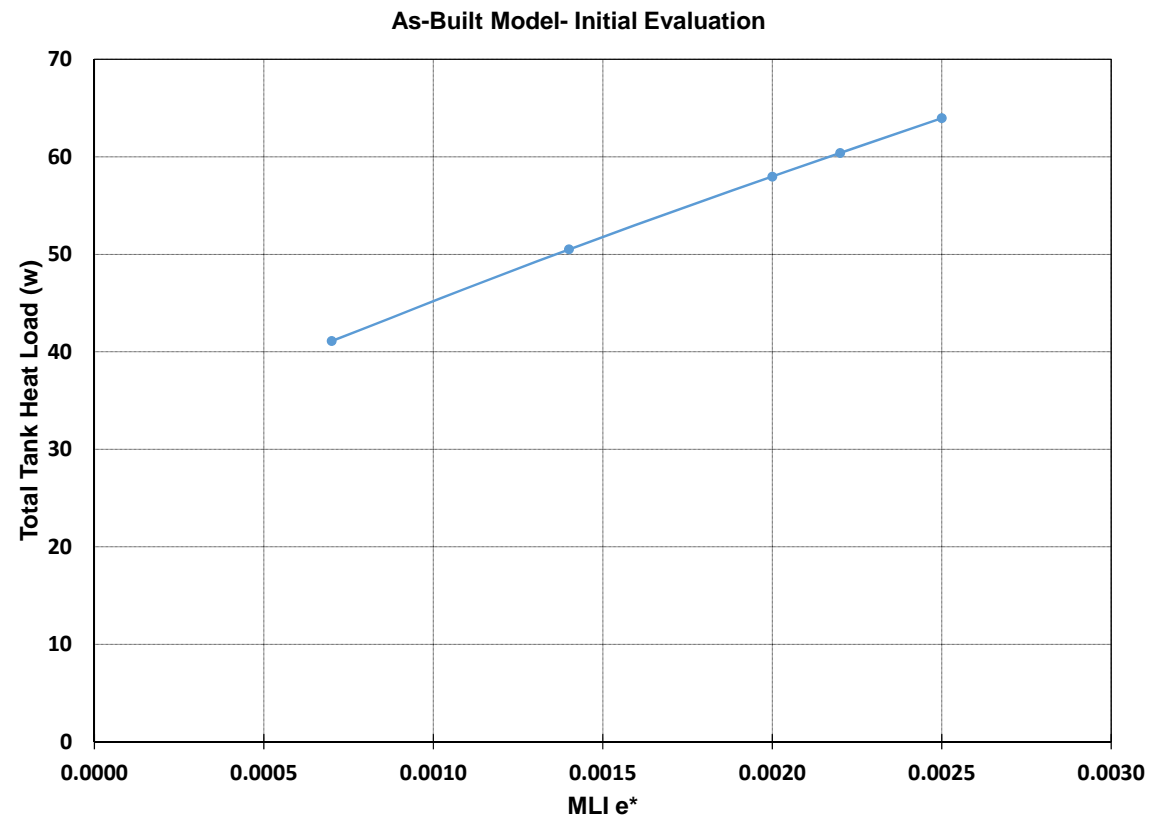



Thermal Analysis

estar = 0.0022

Heat Flow (watts)

Totals	LH2	-40.1
	Ullage	-20.3

MLI	Tank & Upper Cover	-20.2
	Lower Cover	-10.3

Struts	Upper	-4.6
	Lower Struts	-10.7
	Purge Bag	-2.6

Wetted Lines	AJ Recirculation	-9.2
	Lower Pressurization	-0.8
	Joint TVS Supply	-0.6
	Fill/Drain	-0.3
	AJ TVS	-0.1
	LAD TVS	-0.1

Non-Wetted Lines	Vacuum Lines (C-seals)	-4.7
	Vent Line	-3.1

Pressure Transducers	Fil/Drain Line	-0.3
----------------------	----------------	------

Valves	AJ Recirculation Line	-0.3
--------	-----------------------	------

Valves	Lower Pressurization	-0.9
	Fill/Drain	-0.4
	AJ TVS	-0.3
	LAD TVS	-0.2

Total of Components = -59

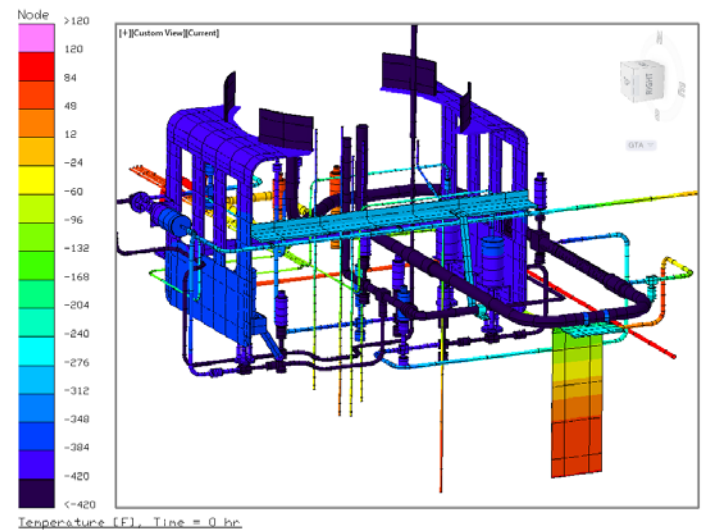
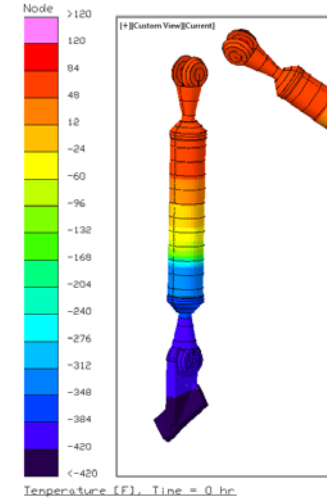
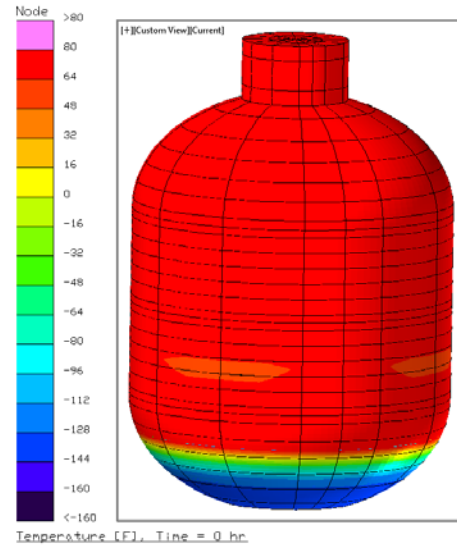

Correlation Efforts

- Strut Detailed Model Correlation
- Completed by Ken Kittredge

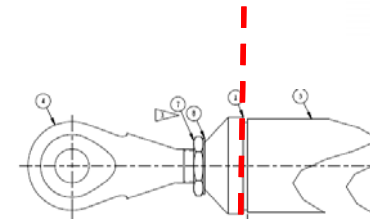
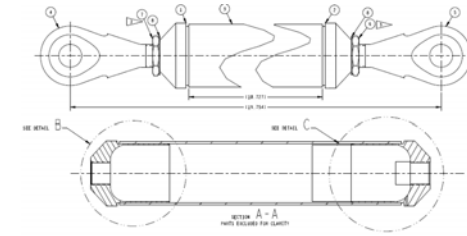

1st Boil-off Test: Upper Struts

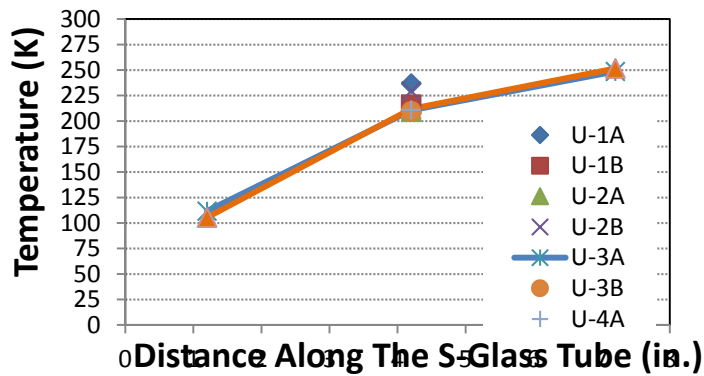

1st Boil-off Test: Lower Struts

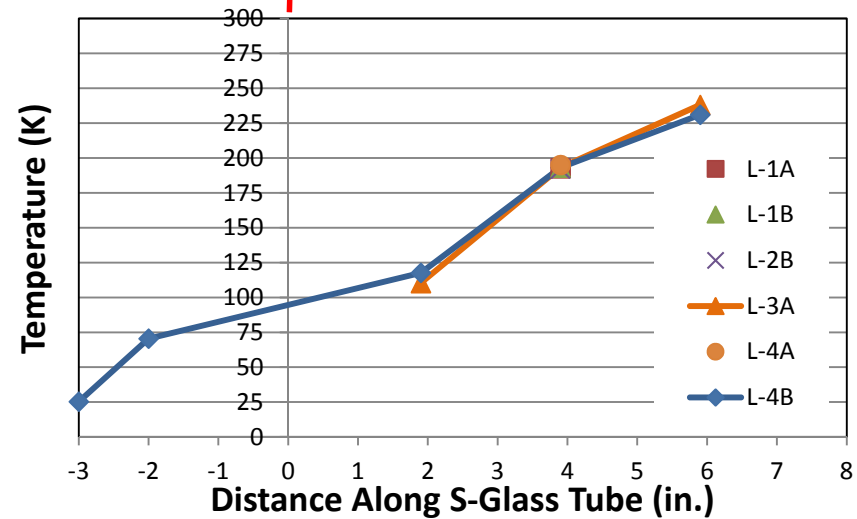

Correlation Efforts

- Strut Detailed Model

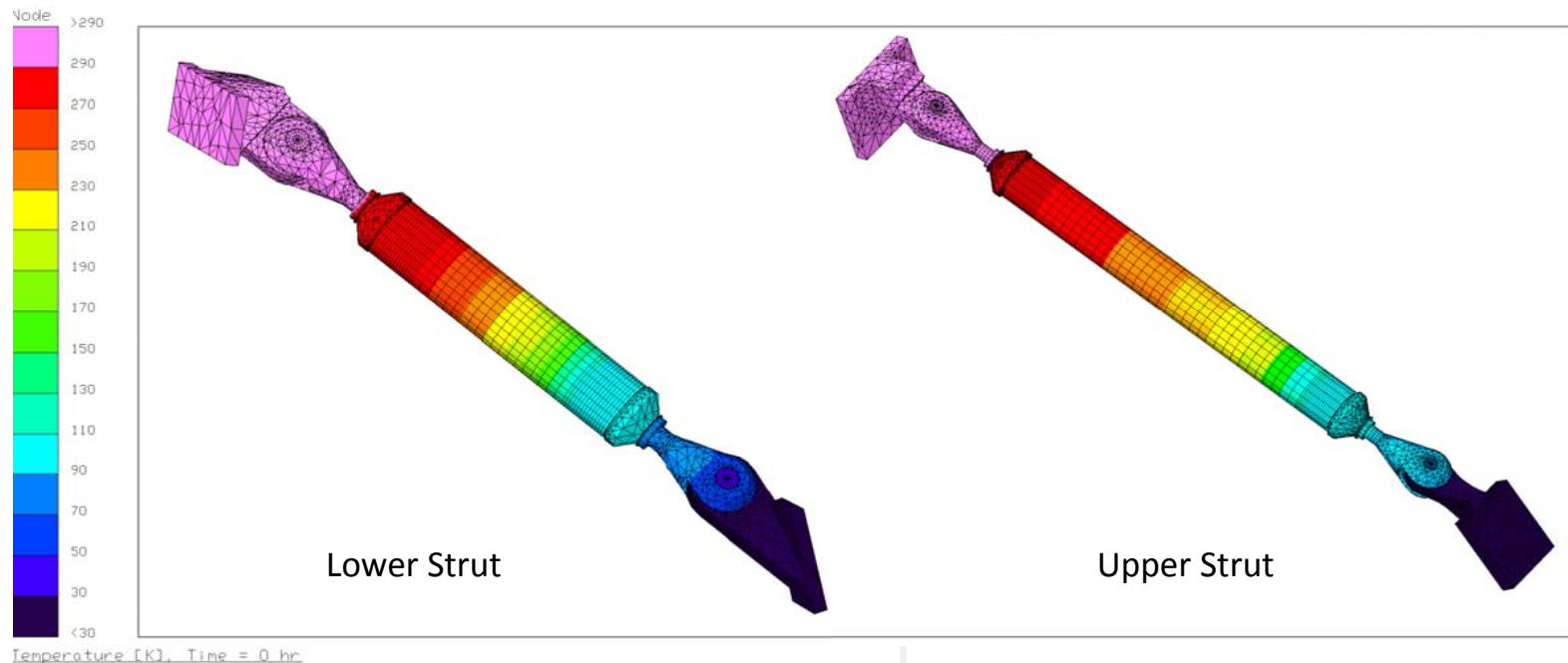

	Lower Strut (Test 1/Test 2)	Upper Strut (Test 1/Test 2)
Correlation (w/strut)	0.58/0.56	0.31/0.29
(w total)	4.6/4.5	2.5/2.3
Integrated Model (w/strut)	1.3/	0.56/
(w total)	10.7/	4.6/

Radiation is a major contributor



Future Plans

- **Analytical Efforts**
 - Add “measurements” to the integrated model
 - Add logic to capture enthalpy in the vent flow network on a per node basis
 - Begin model correlation of the integrated model
 - Start with struts
 - Next, environment inside the lower MLI cover
 - MLI ϵ^* and others
- **Write the test report**



<<<<<< Backup Slides >>>>>>>

Test Methods

Boil-off Test

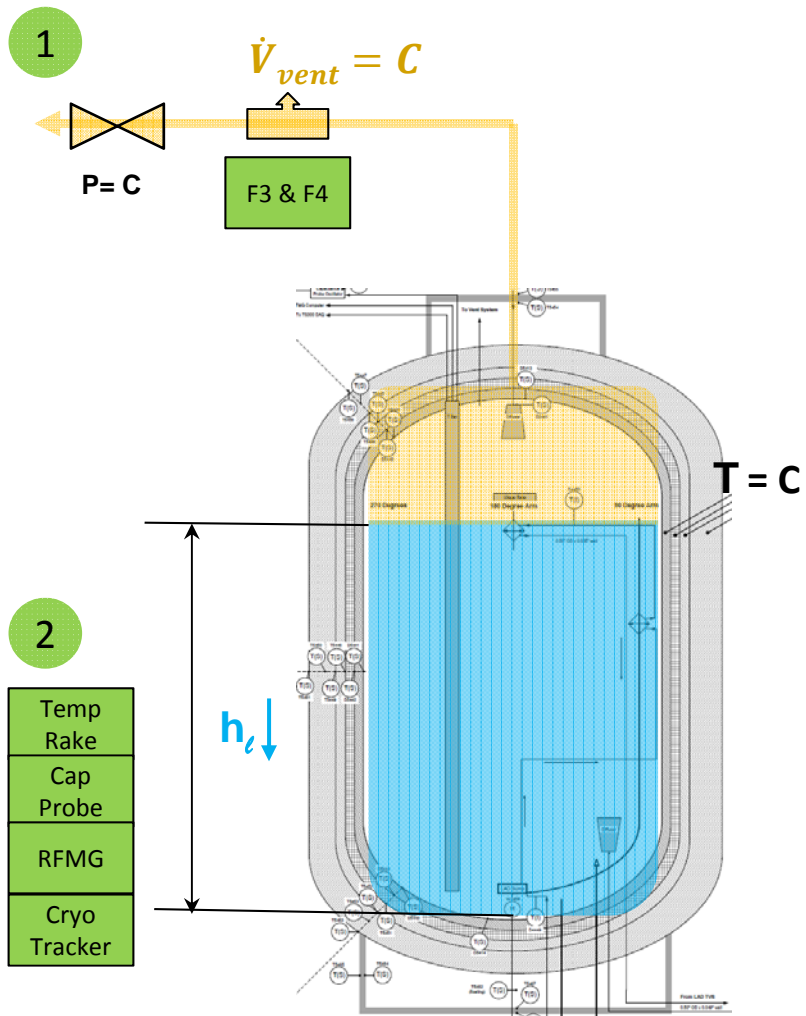

Pressure Rise Test

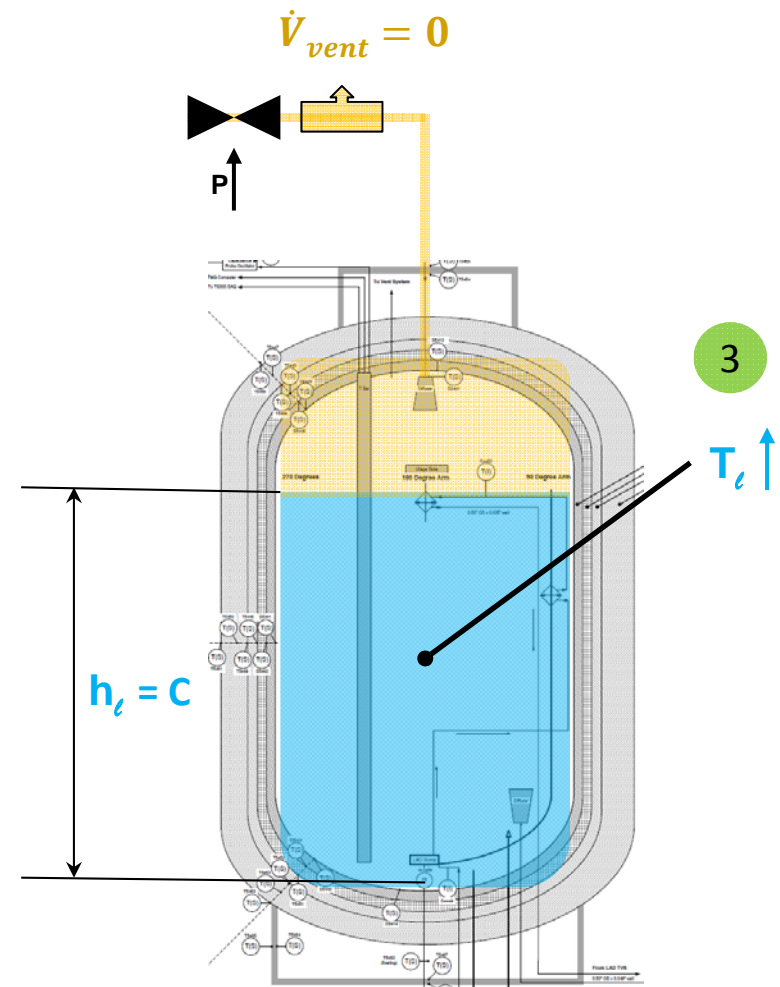

Measurements-to-Heat Loads

Boil-off Test

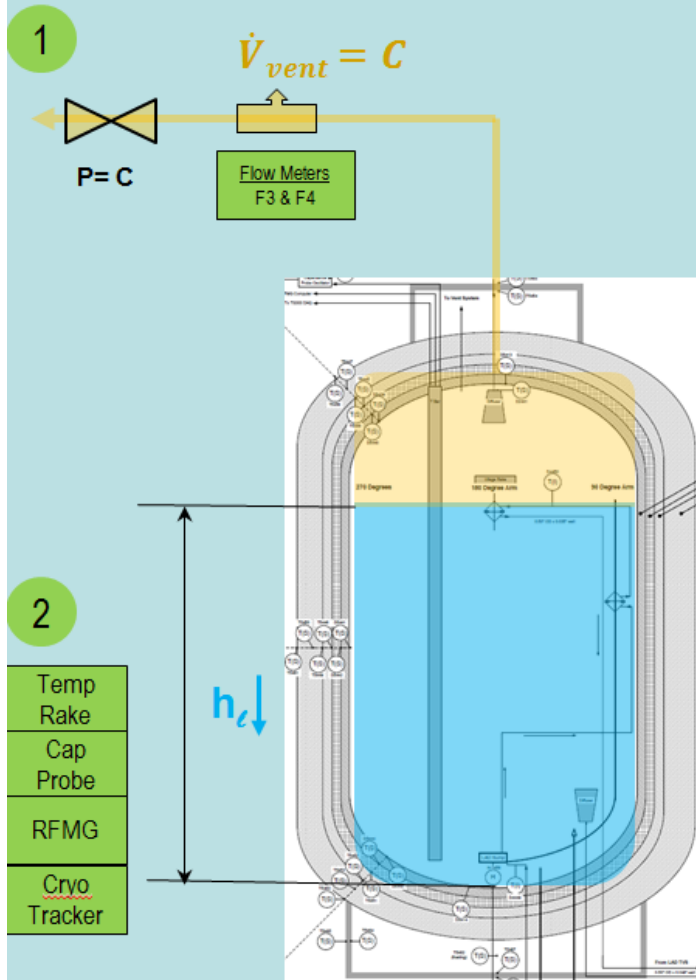

1

$$\dot{m}_{vent} = \rho_{vent} * \dot{V}_{vent}$$

2

$$\dot{m}_{boiloff} = \frac{\rho_l * (V_1 - V_2)}{dt}$$

$$\dot{m}_{boiloff} = \frac{\rho_{vent} * \dot{V}_{vent}}{(1 - \frac{\rho_u}{\rho_l})} = (1.03) * \dot{m}_{vent}$$

Energy leaving the tank equals the latent heat of boiloff plus the sensible heat into the ullage picked up between the surface and the vent exit. This can also be based on the rate of liquid level change.

$$\dot{q}_T = \dot{q}_{boiloff} + \dot{q}_{sensible}$$

$$\dot{q}_T = \dot{m}_{boiloff} * h_{LHV} + \dot{m}_{vent} * (h_{vent} - h_{sat})$$

Agenda – Day 1



November 18, 2014 (Day 1)		
Time (CST)	Topic	Presenter
8:00-8:30 am	Registration, Welcome and Introductions	
8:30 – 9:15 am	History & Manufacture of EDU	Arthur Werkheiser
9:15 – 10:00 am	Multi-Layer Insulation (MLI)	Jessica Wood
10:00 – 10:15 am	BREAK	
10:15 – 11:30 am	Thermal Analysis of EDU	Tim Page
11:30 – 1:00 pm	LUNCH	
1:00 – 1:45 pm	Radio Frequency Mass Gauge (RFMG)	Greg Zimmerli
1:45 – 2:45 pm	Pressurization test results	Jonathan Stevens
2:45 – 3:15 pm	Fill model	Ali Hedyat
3:15 – 4:00 pm	Cryo Valves	Becky Crownover
4:00 – 4:20 pm	Liquid Acquisition Device (LADs)	Maureen Kudlac
4:20 – 4:45 pm	TVS	Joe Zoeckler
4:45 – 5:00 pm	Success criteria & Wrap up	Arthur Werkheiser
	Adjourn to the Firehouse Pub	