



US009031689B1

(12) **United States Patent**
Fink et al.

(10) **Patent No.:** **US 9,031,689 B1**
(45) **Date of Patent:** **May 12, 2015**

(54) **SYSTEMS AND METHODS FOR
RFID-ENABLED DISPENSER**

(71) Applicant: **The United States of America as
represented by the Administrator of
the National Aeronautics and Space
Administration, Washington, DC (US)**

(72) Inventors: **Patrick W. Fink**, Missouri City, TX
(US); **Gregory Y. Lin**, Friendswood, TX
(US); **Timothy F. Kennedy**, Sugar Land,
TX (US); **Phong H. Ngo**, Friendswood,
TX (US); **Diane Byerly**, Seabrook, TX
(US)

(73) Assignee: **The United States of America as
represented by the Administrator of
the National Aeronautics and Space
Administration, Washington, DC (US)**

(*) Notice: Subject to any disclaimer, the term of this
patent is extended or adjusted under 35
U.S.C. 154(b) by 286 days.

(21) Appl. No.: **13/791,584**

(22) Filed: **Mar. 8, 2013**

Related U.S. Application Data

(60) Provisional application No. 61/671,403, filed on Jul.
13, 2012.

(51) **Int. Cl.**
G07F 9/02 (2006.01)
G06F 7/10 (2006.01)
G06Q 10/08 (2012.01)
A47F 1/12 (2006.01)

(52) **U.S. Cl.**
CPC **G06F 7/10** (2013.01); **G07F 9/026**
(2013.01); **G06Q 10/087** (2013.01); **A47F**
1/126 (2013.01)

(58) **Field of Classification Search**

CPC **G06Q 10/087**; **G07F 9/026**; **A47F 1/126**
USPC **221/6**, **7**; **700/236**
See application file for complete search history.

(56) **References Cited**

U.S. PATENT DOCUMENTS

6,189,727	B1 *	2/2001	Shoenfeld	221/2
6,684,126	B2 *	1/2004	Omura et al.	700/231
6,752,277	B1 *	6/2004	Sempliner	211/59.3
8,401,697	B2 *	3/2013	Templer et al.	700/236
8,812,378	B2 *	8/2014	Swafford et al.	705/28
8,933,789	B1 *	1/2015	Fink et al.	340/10.1
2006/0132351	A1 *	6/2006	Le Sesne	342/124
2006/0145863	A1	7/2006	Martin et al.	
2007/0254080	A1	11/2007	Schackmuth et al.	
2007/0268139	A1	11/2007	Sweeney, II	
2012/0091162	A1 *	4/2012	Overhultz et al.	221/1

* cited by examiner

Primary Examiner — Timothy Waggoner

(74) *Attorney, Agent, or Firm* — Kurt G. Hammerle

(57) **ABSTRACT**

Methods, apparatuses and systems for radio frequency identification (RFID)-enabled information collection are disclosed, including an enclosure, a collector coupled to the enclosure, an interrogator, a processor, and one or more RFID field sensors, each having an individual identification, disposed within the enclosure. In operation, the interrogator transmits an incident signal to the collector, causing the collector to generate an electromagnetic field within the enclosure. The electromagnetic field is affected by one or more influences. RFID sensors respond to the electromagnetic field by transmitting reflected signals containing the individual identifications of the responding RFID sensors to the interrogator. The interrogator receives the reflected signals, measures one or more returned signal strength indications ("RSSI") of the reflected signals and sends the RSSI measurements and identification of the responding RFID sensors to the processor to determine one or more facts about the influences. Other embodiments are also described.

38 Claims, 25 Drawing Sheets

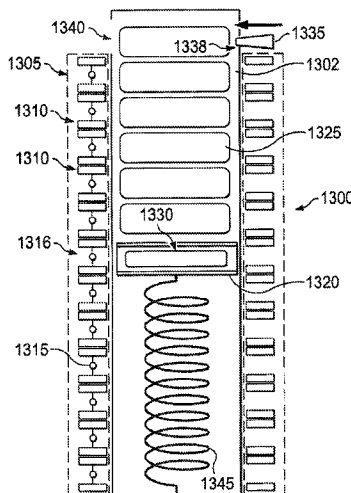

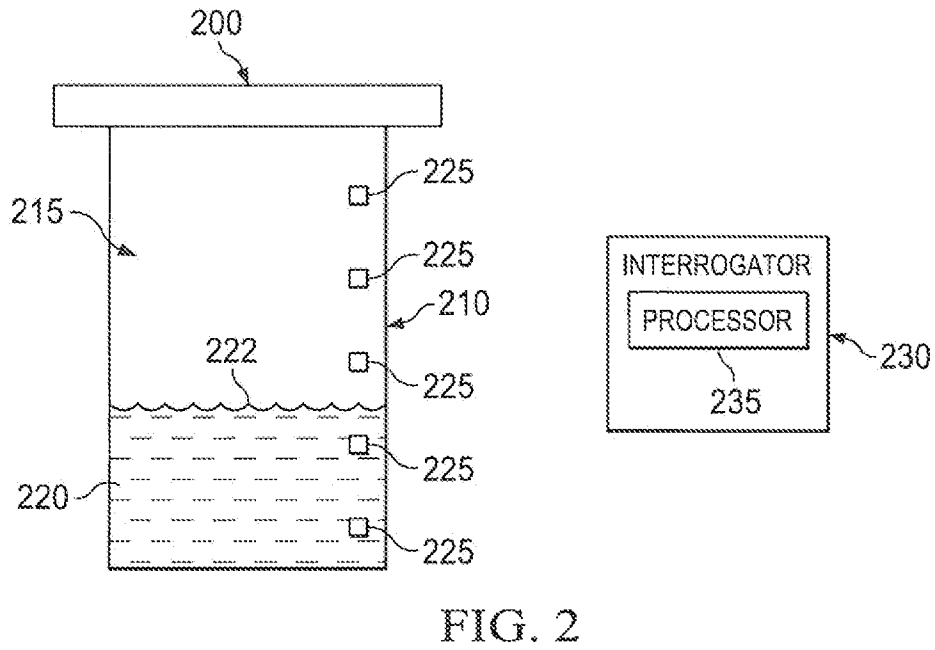
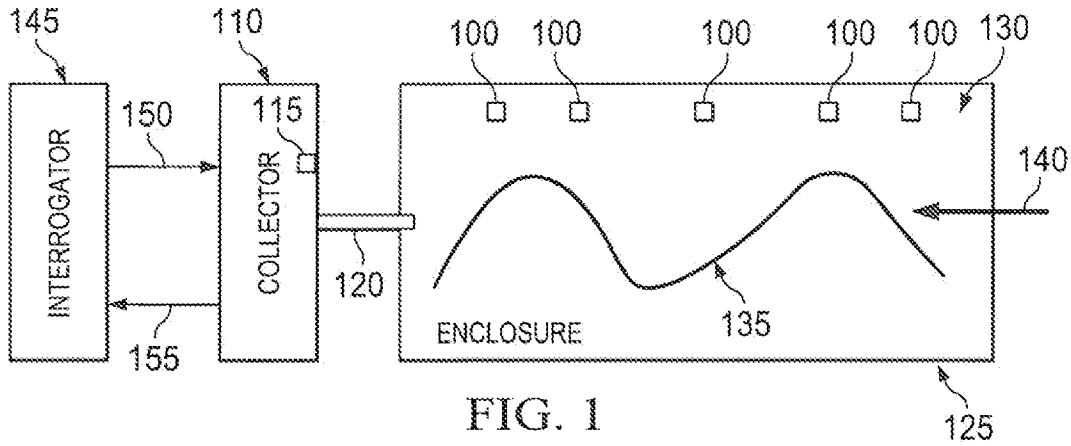

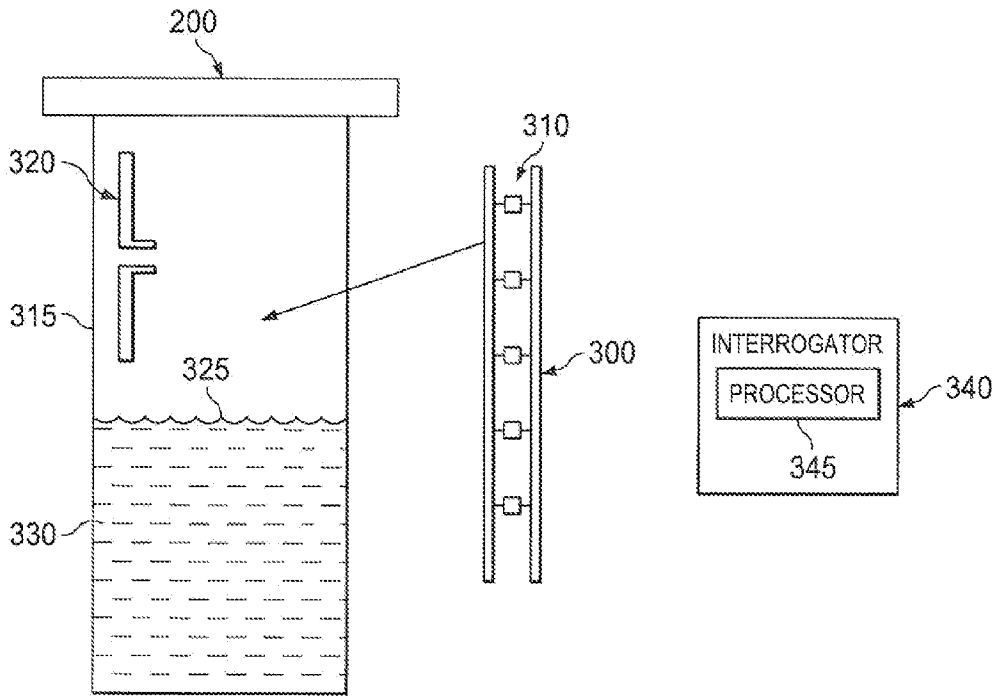

FIG. 3

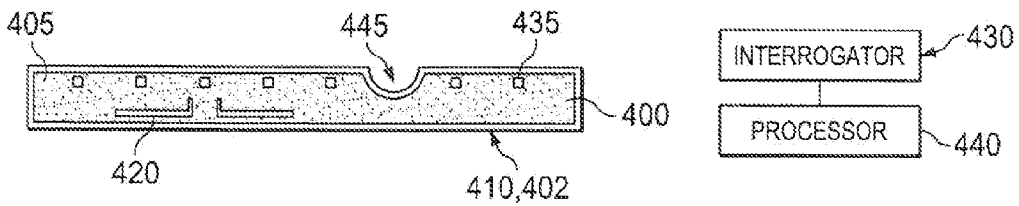

FIG. 4

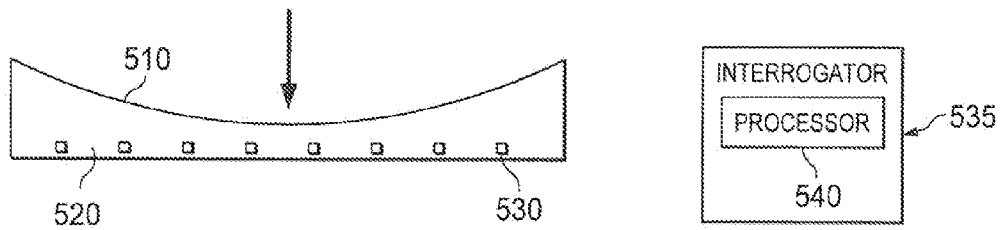

FIG. 5

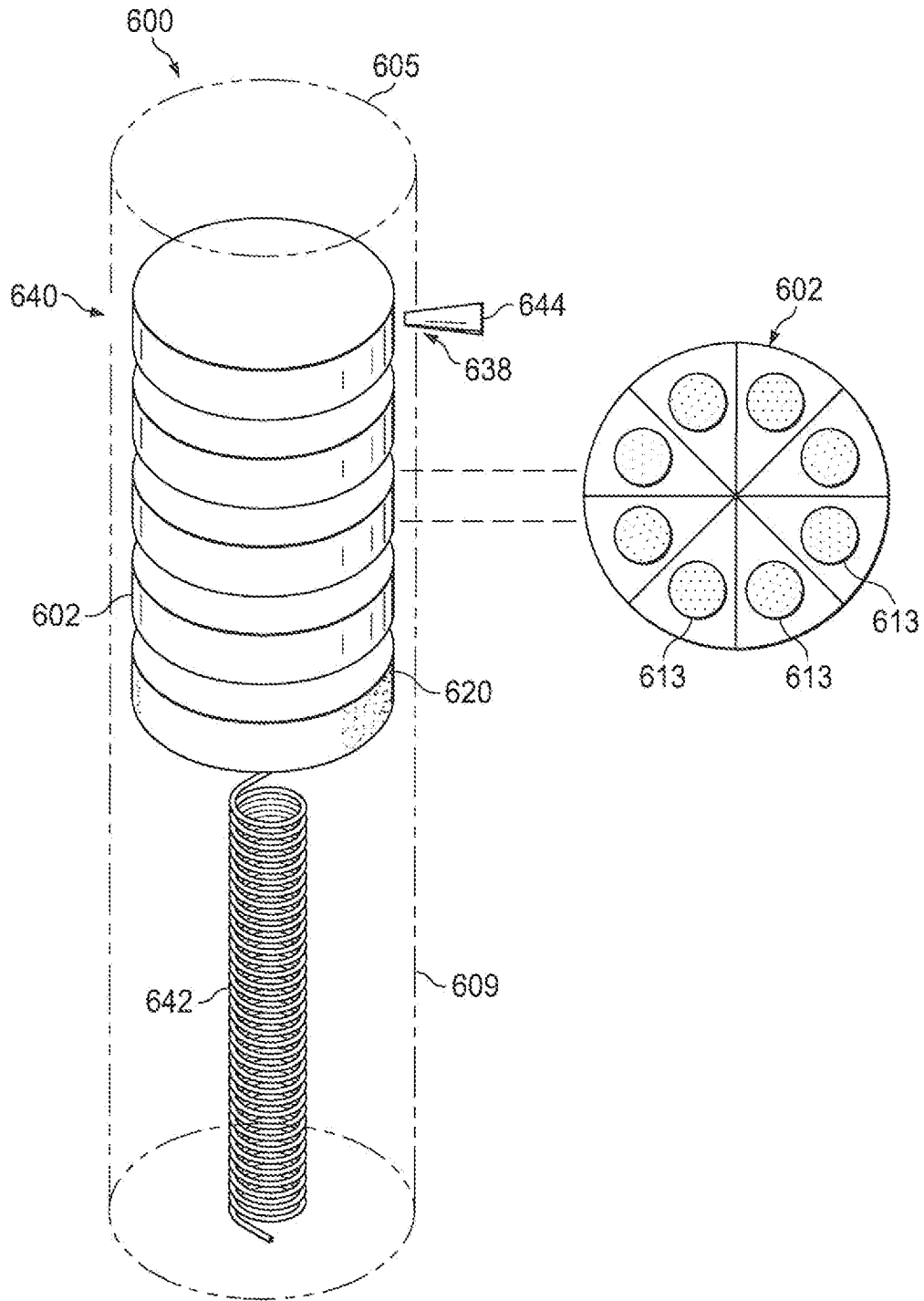

FIG. 6

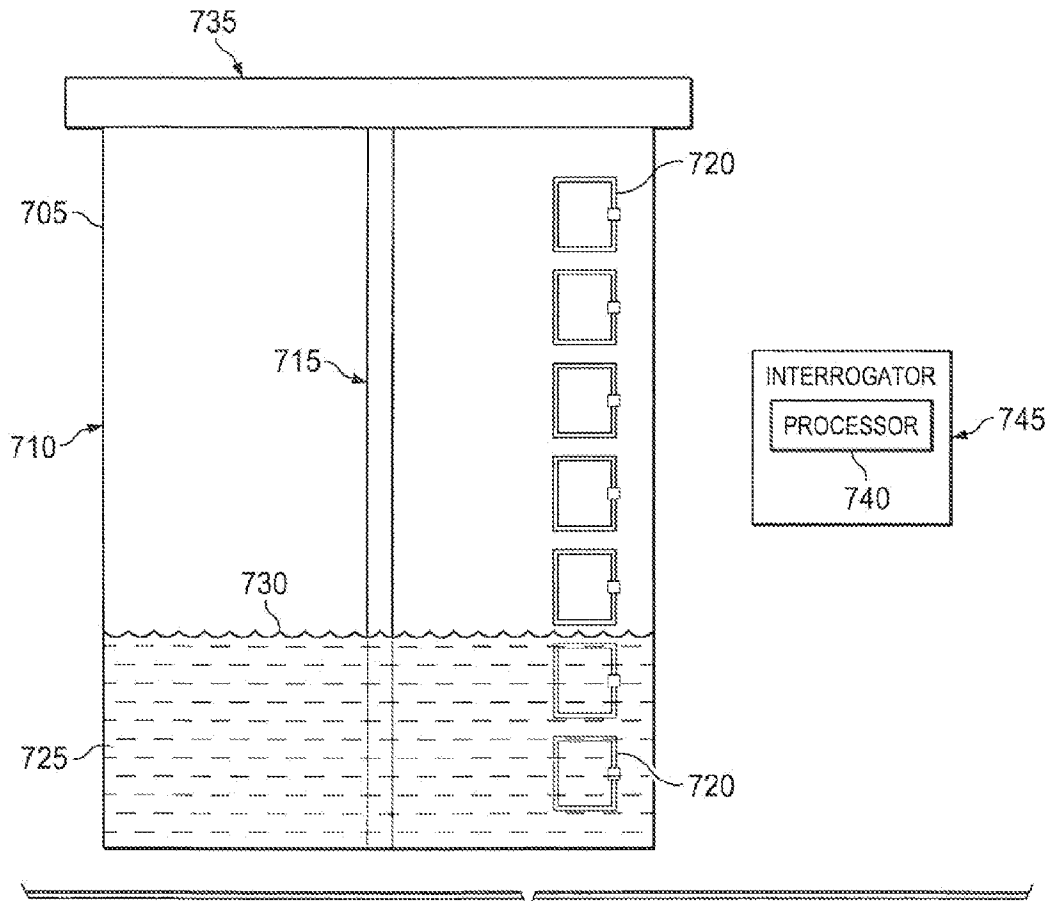
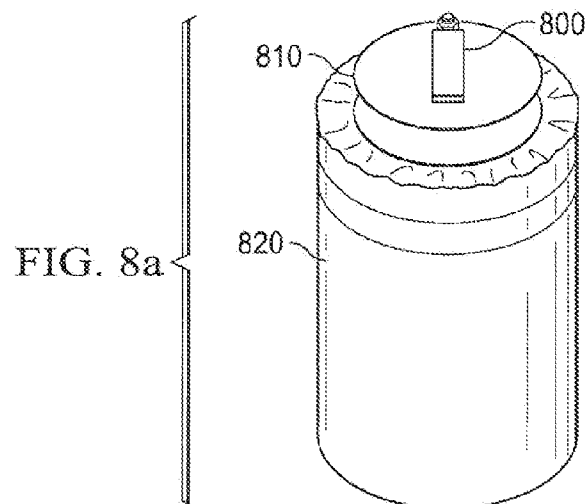

FIG. 7



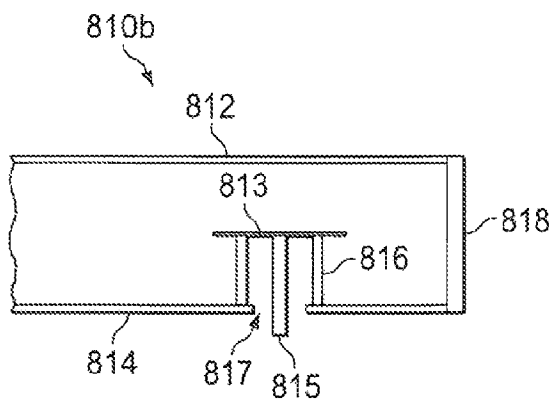

FIG. 8b

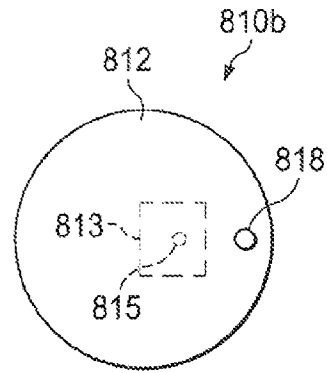

FIG. 8c

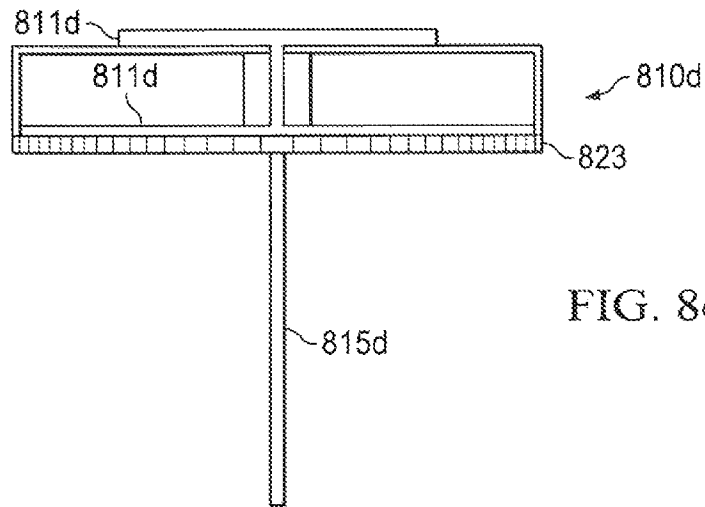

FIG. 8d

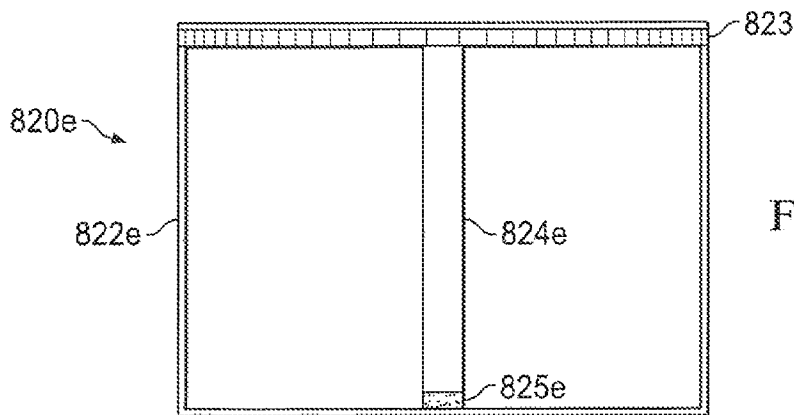

FIG. 8e

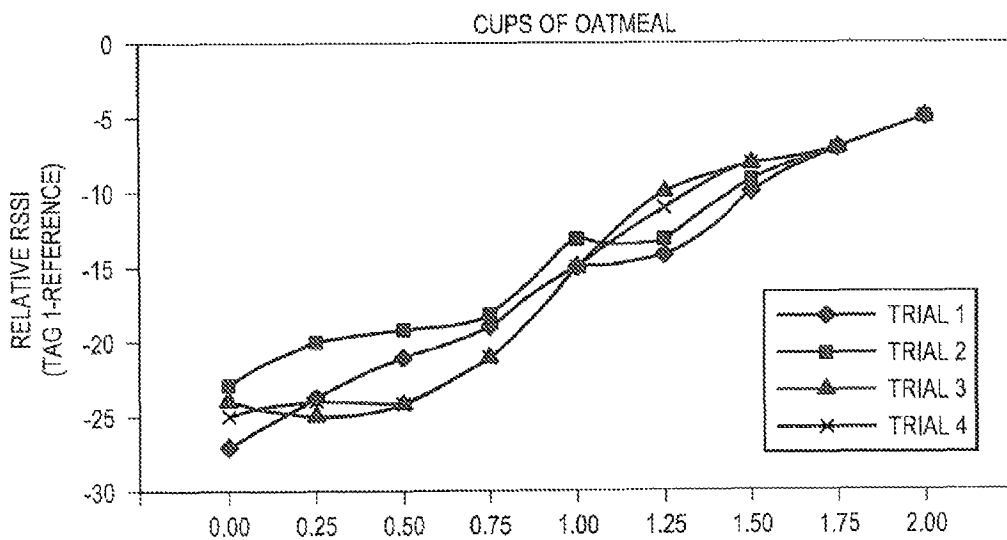

FIG. 9

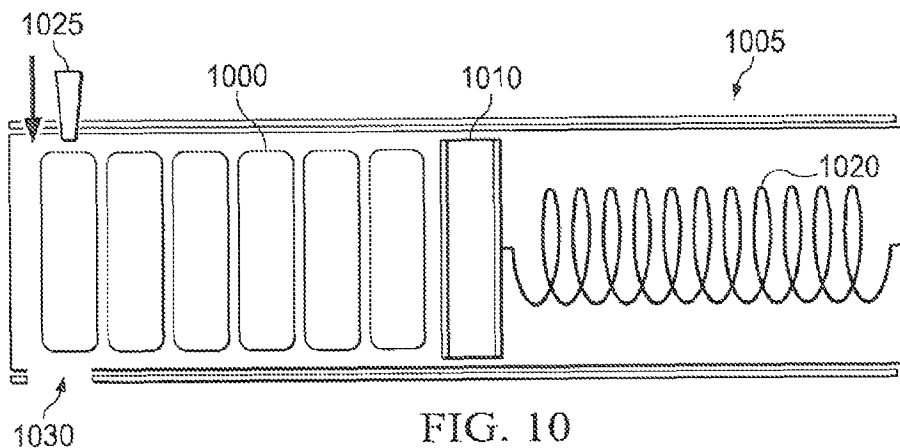

FIG. 10

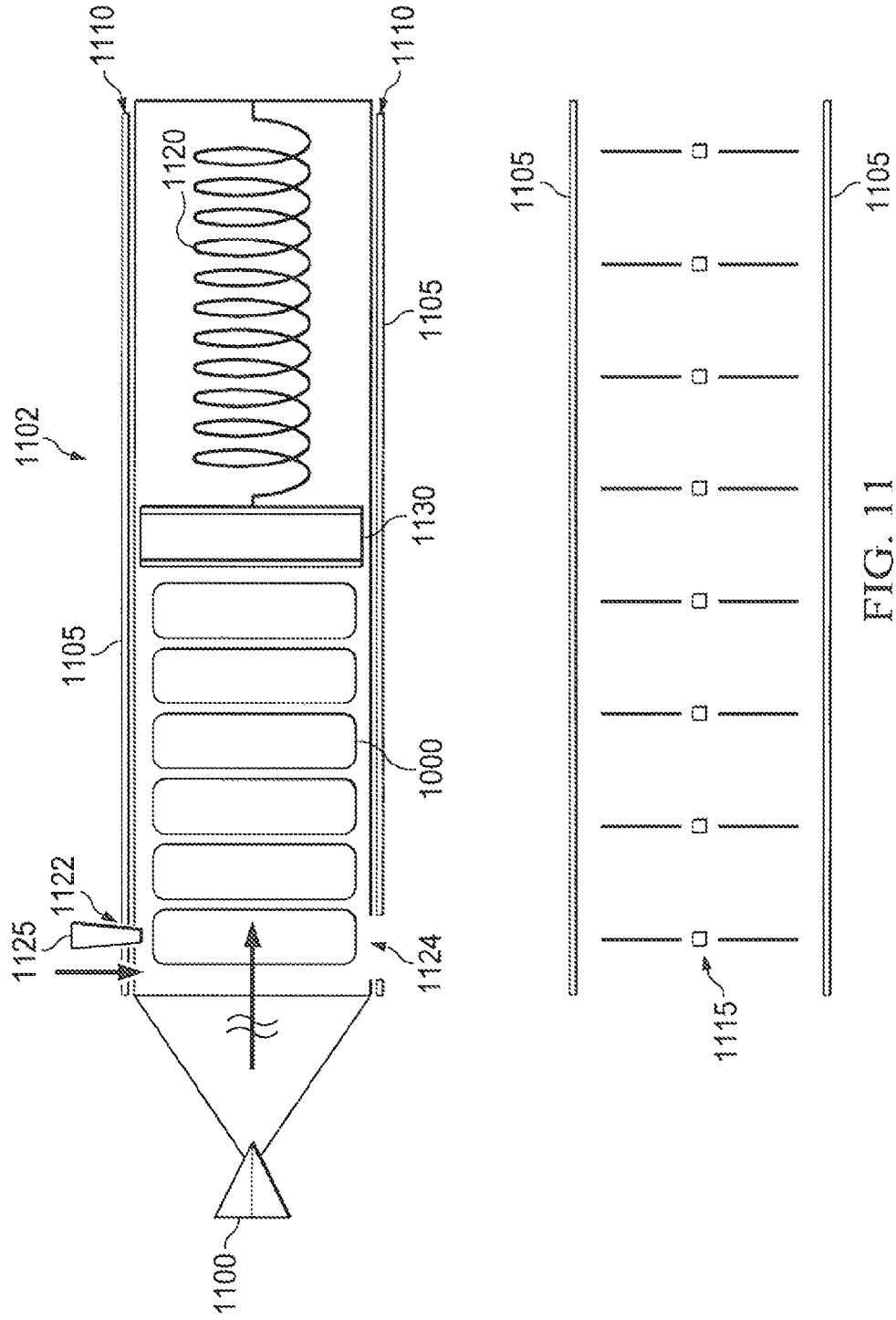

FIG. 11

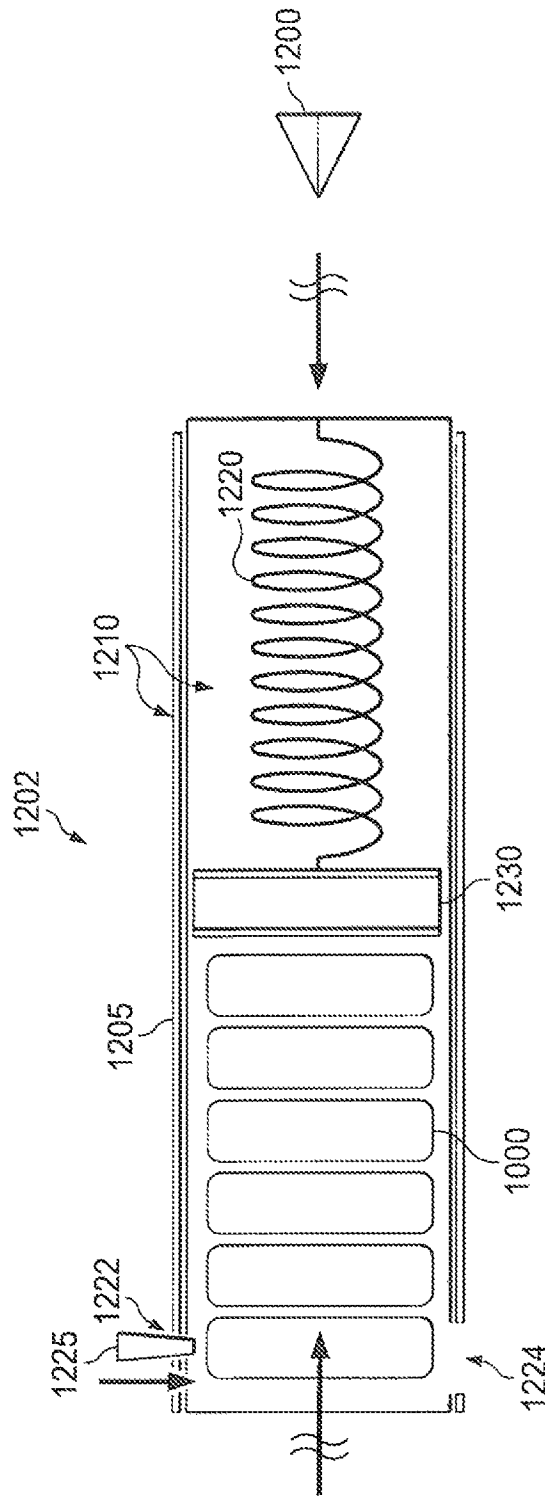

FIG. 12

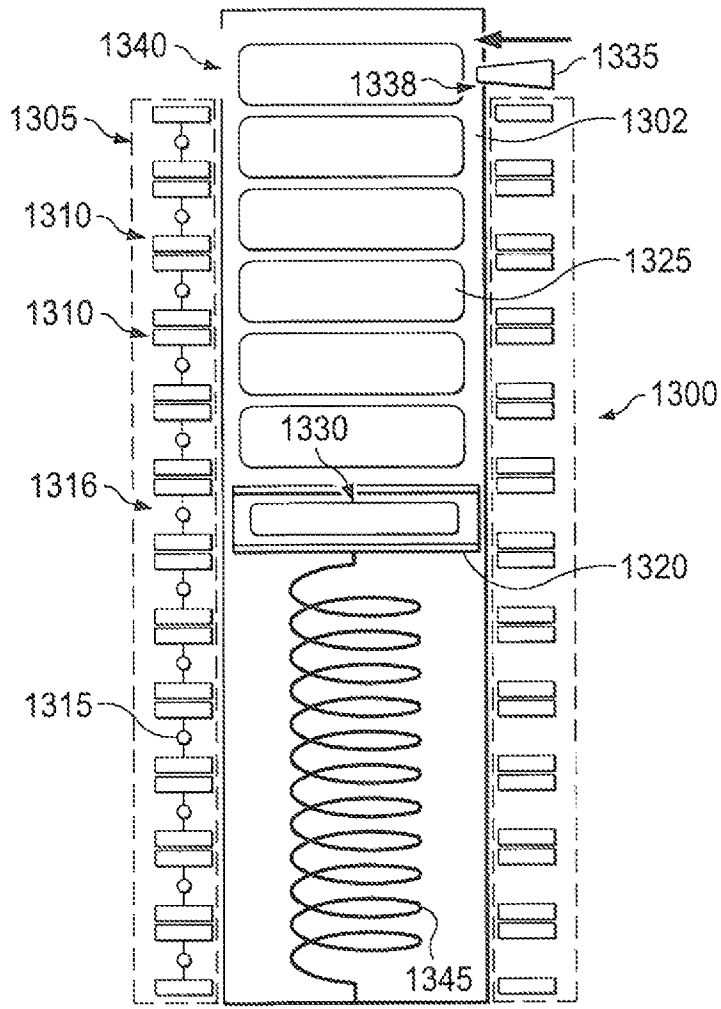

FIG. 13

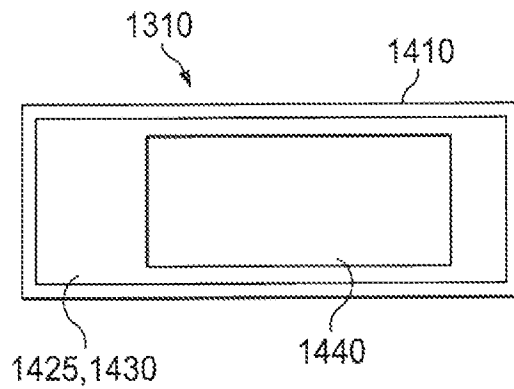
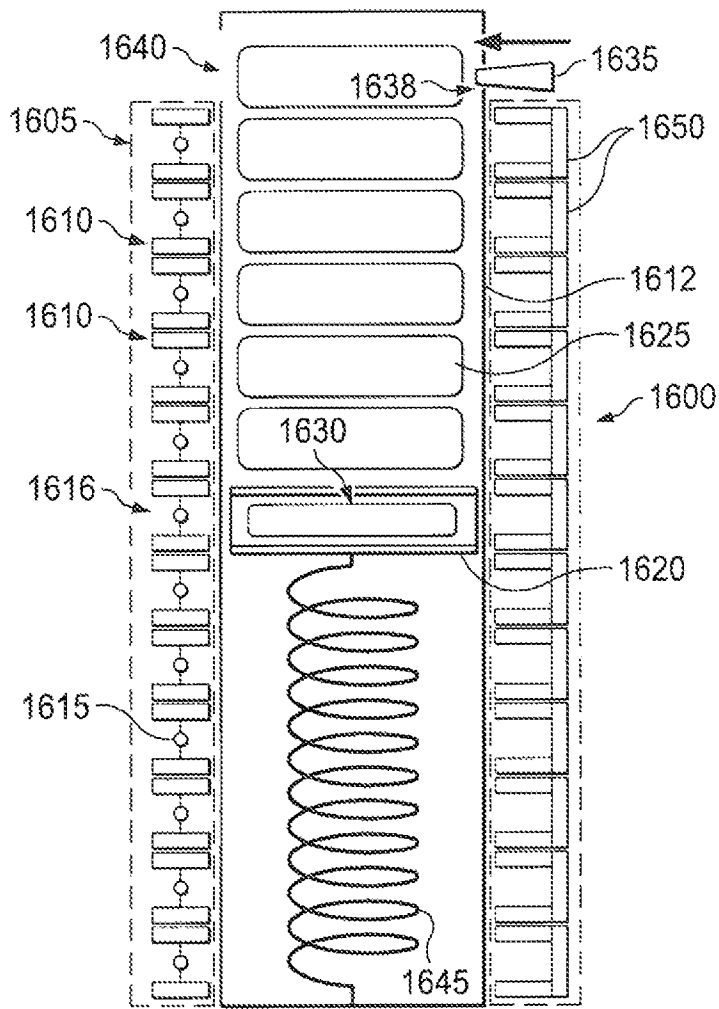
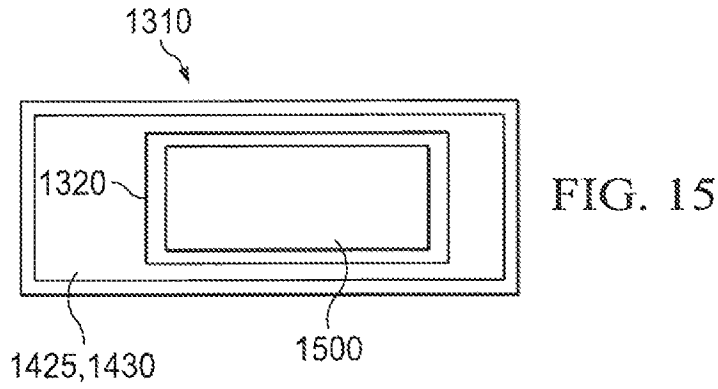

FIG. 14



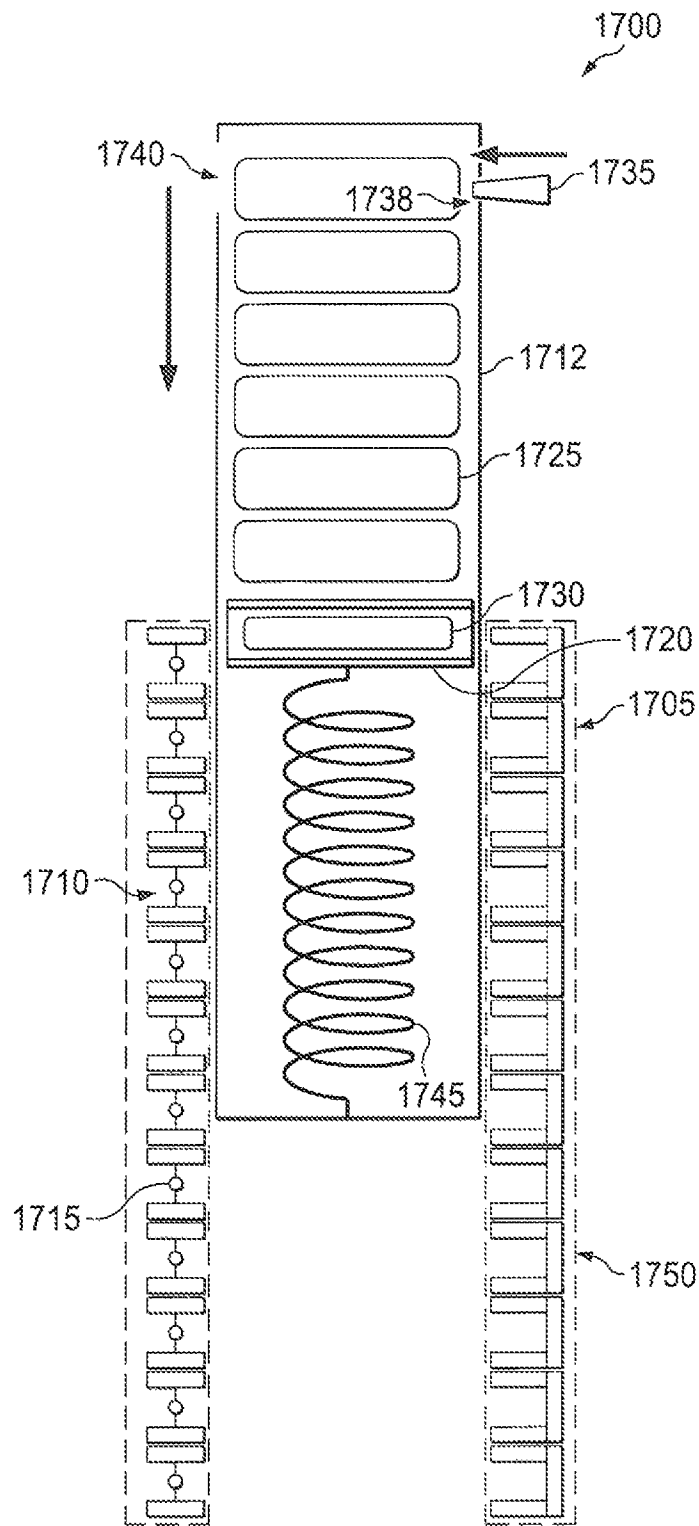

FIG. 17

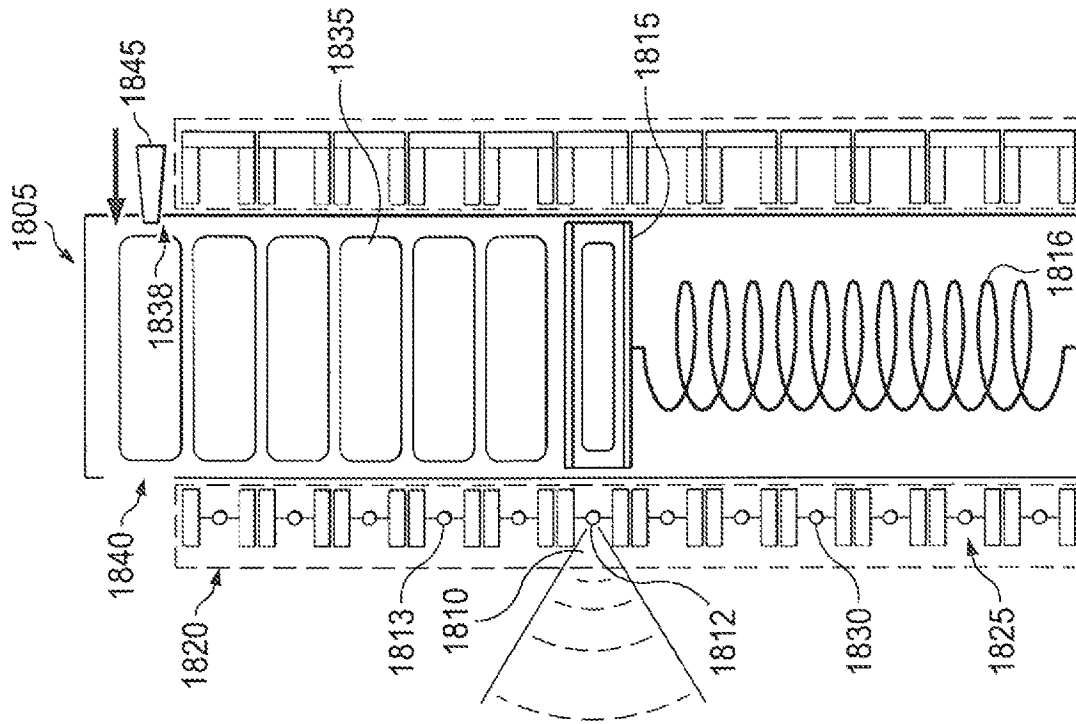
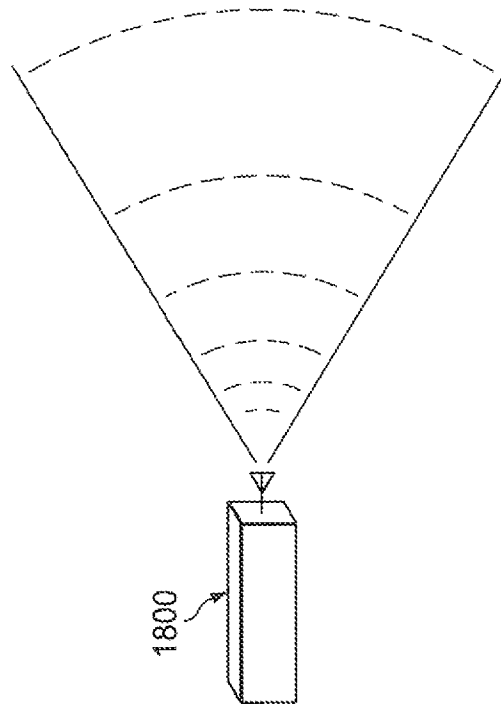

FIG. 18



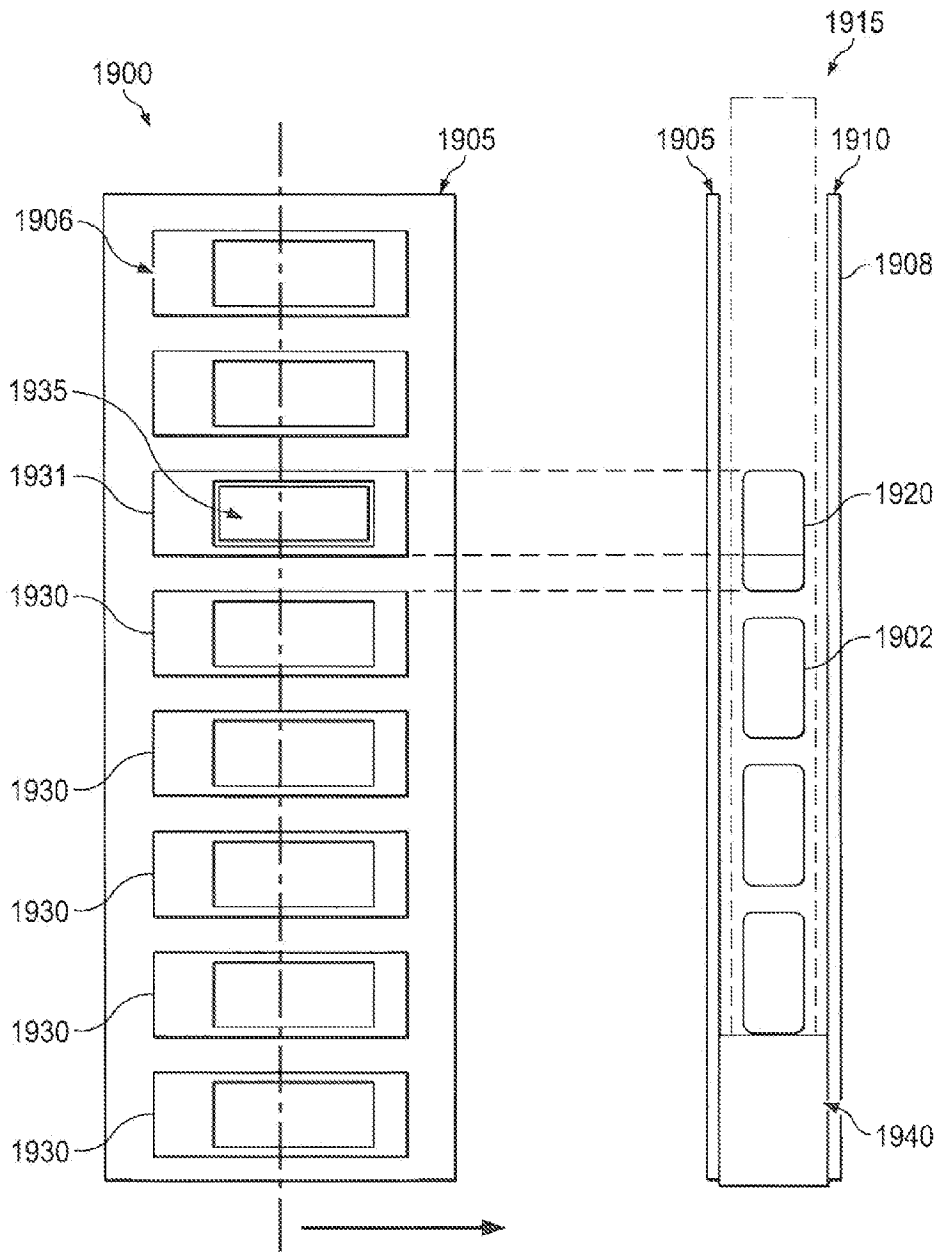

FIG. 19a

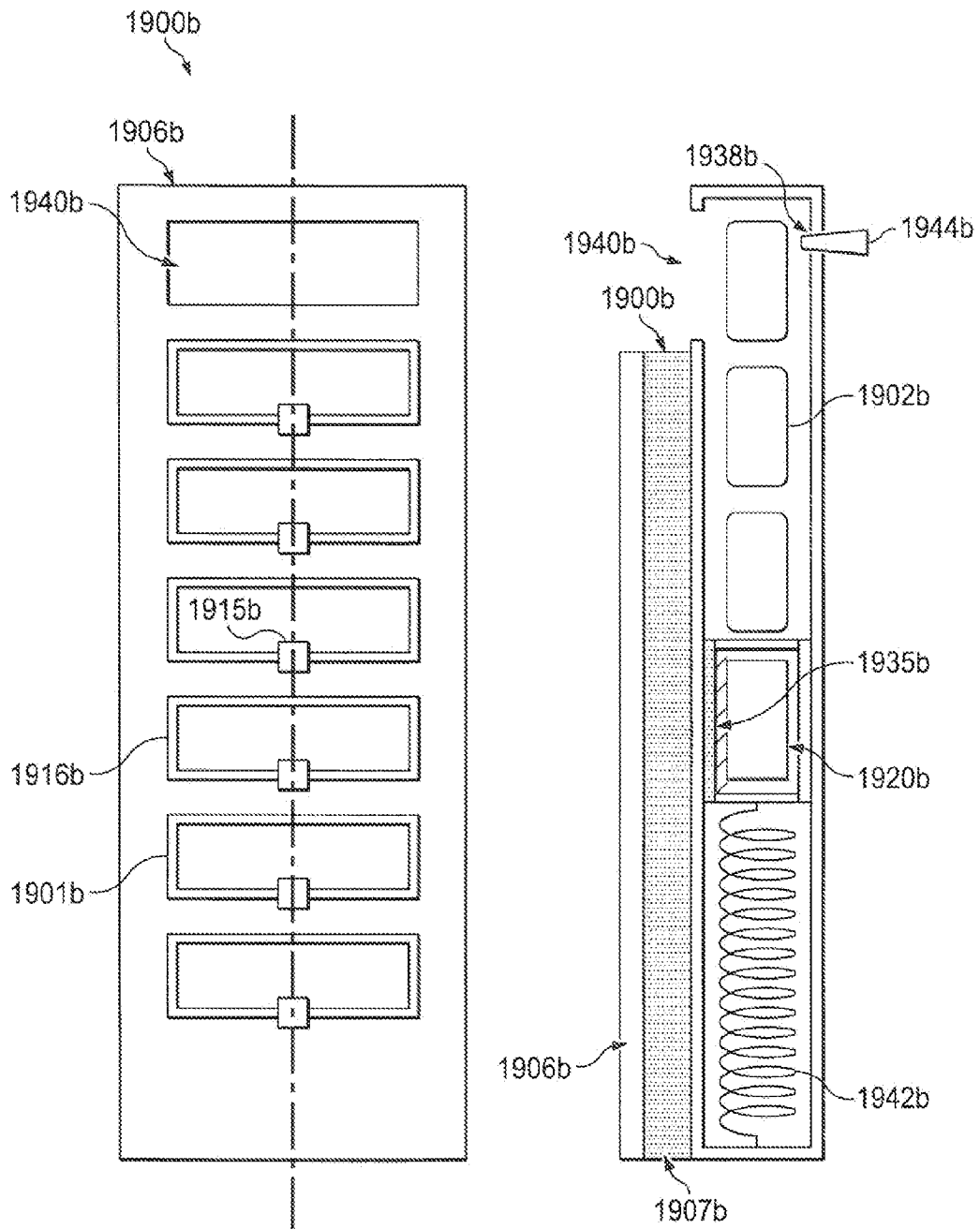

FIG. 19b

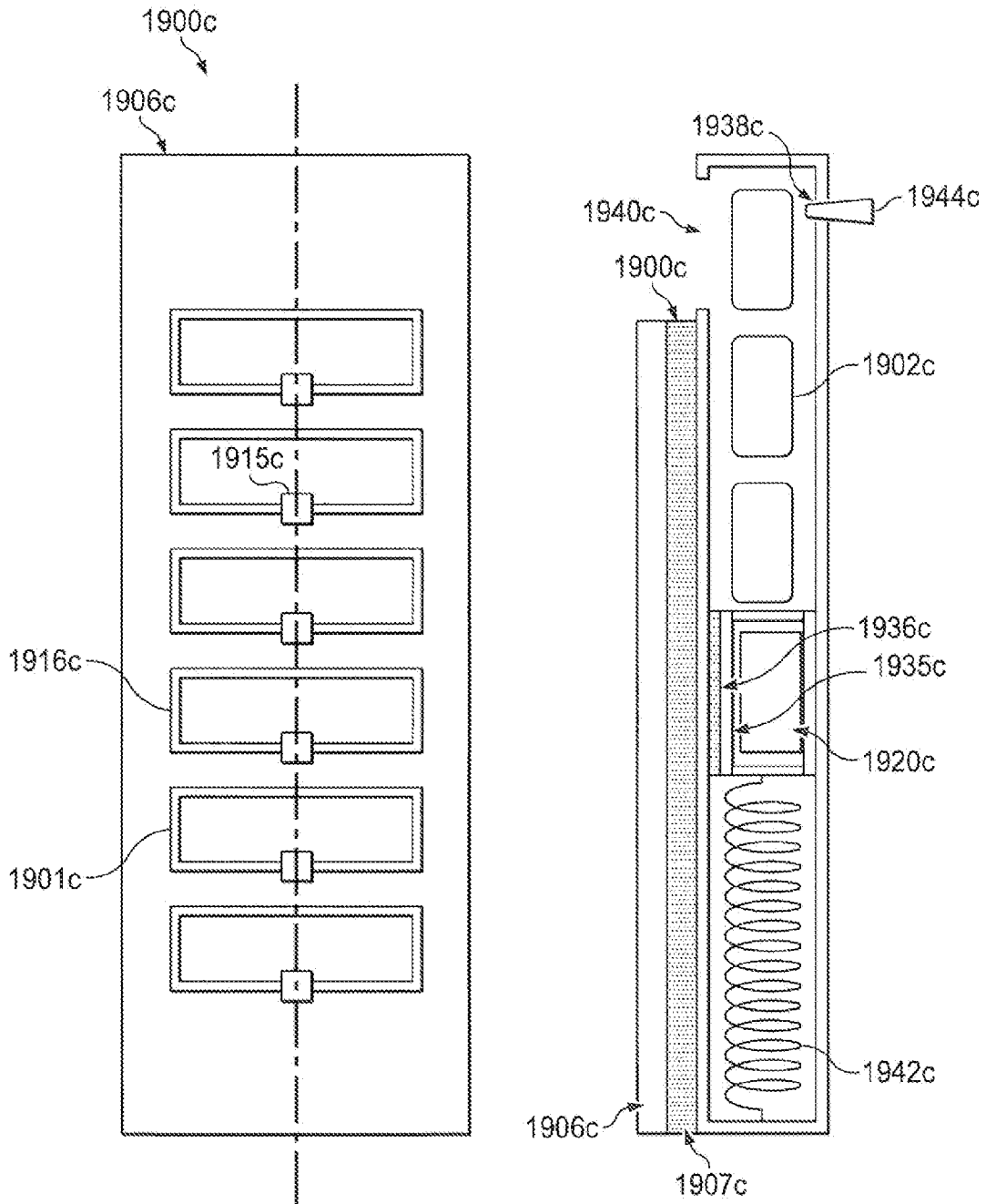

FIG. 19c

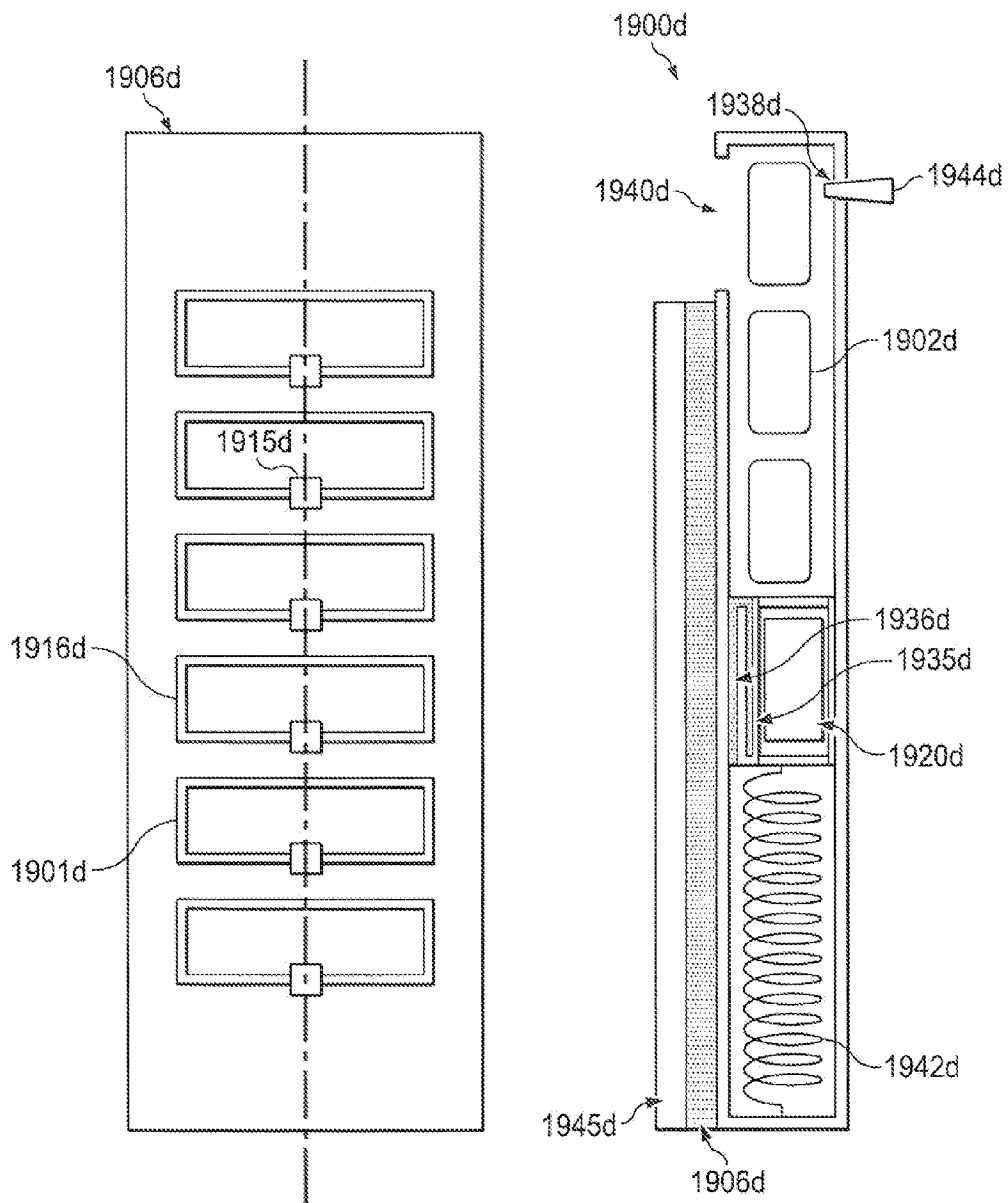
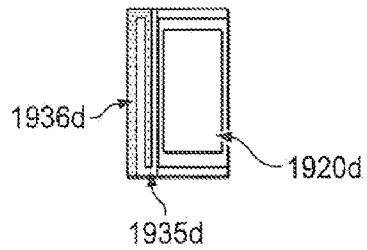

FIG. 19d



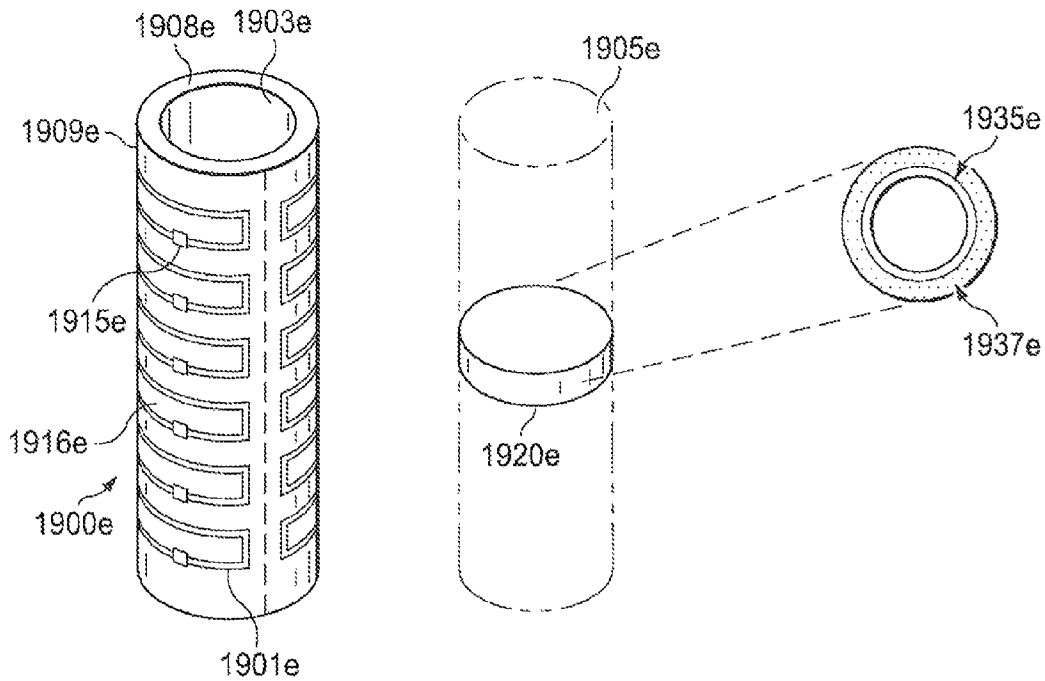

FIG. 19c

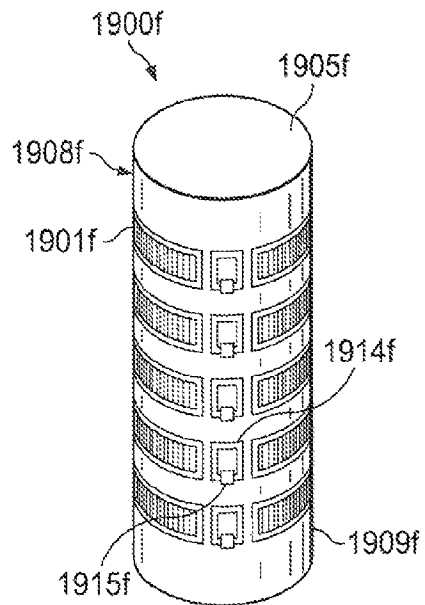

FIG. 19f

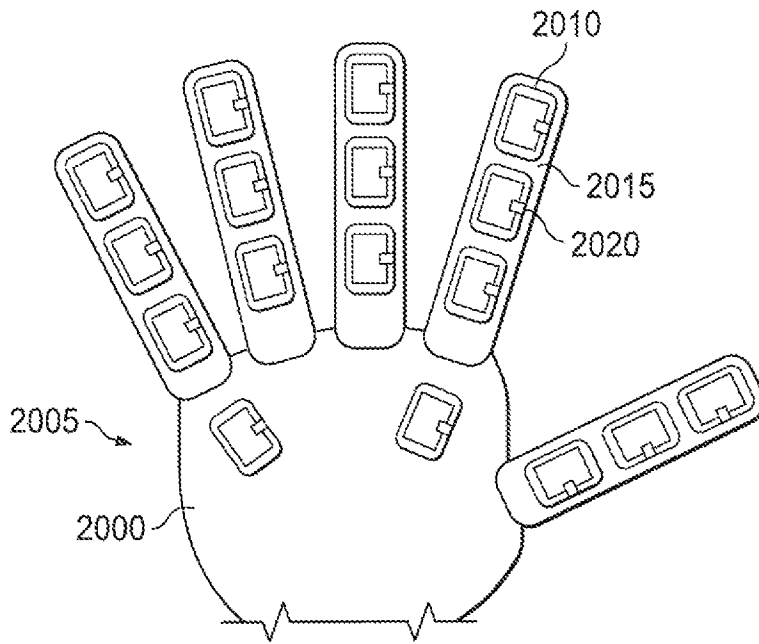

FIG. 20

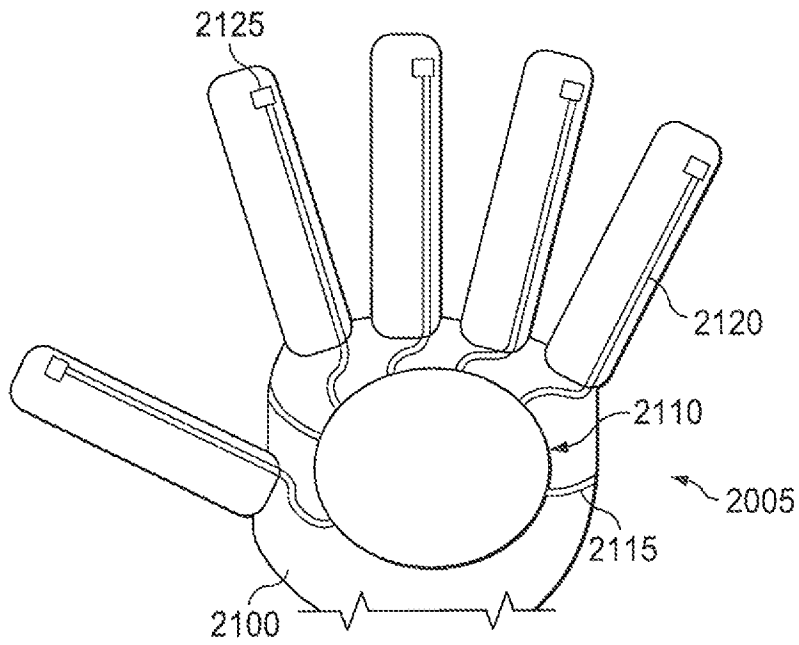

FIG. 21

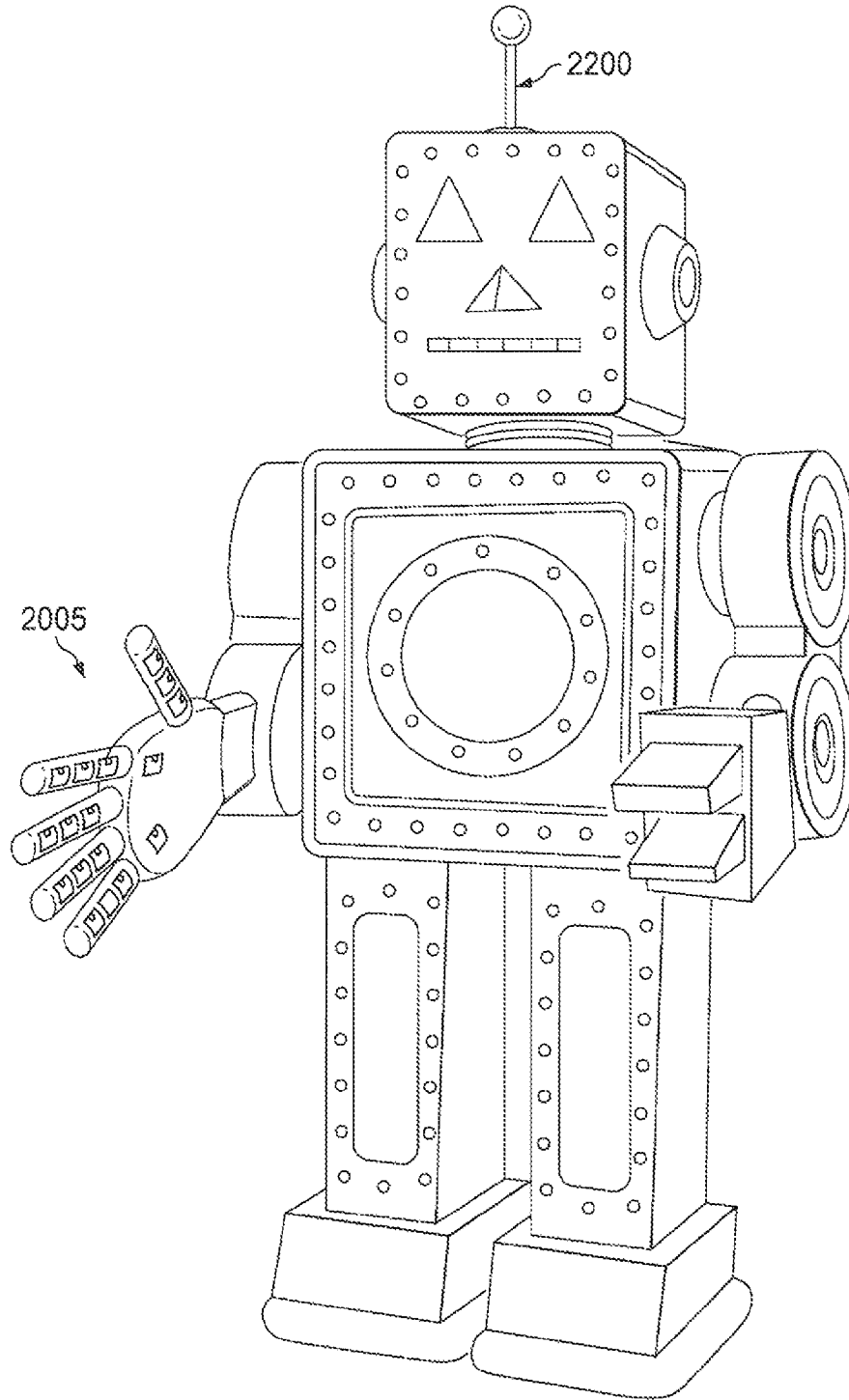
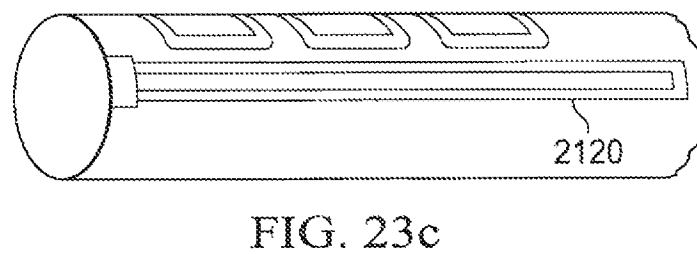
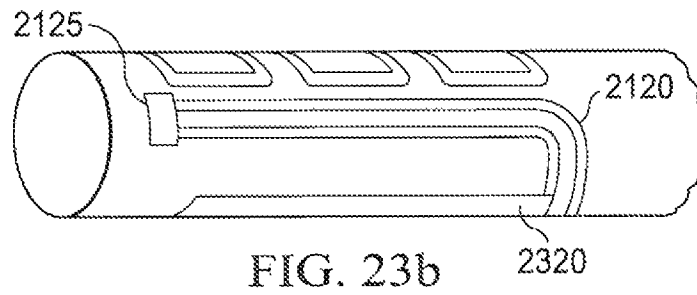
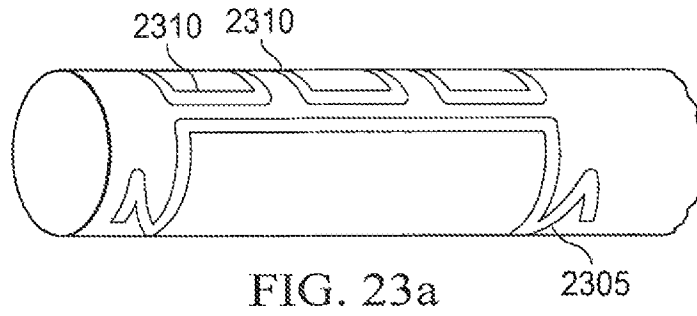

FIG. 22



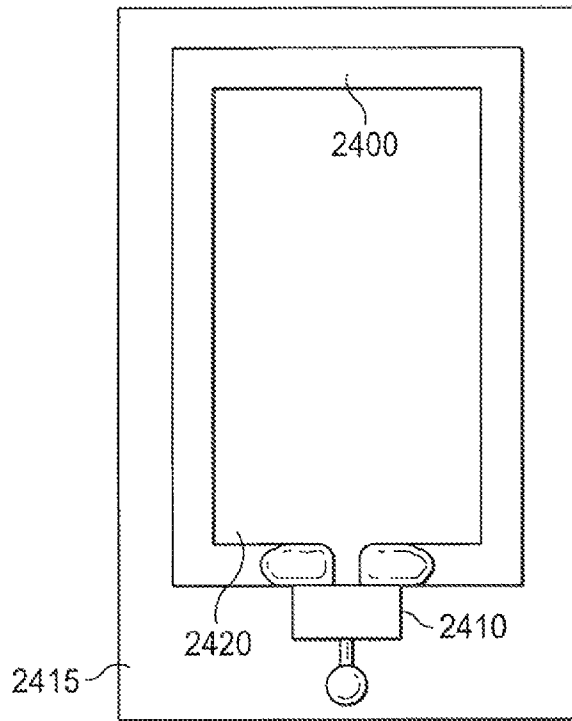

FIG. 24

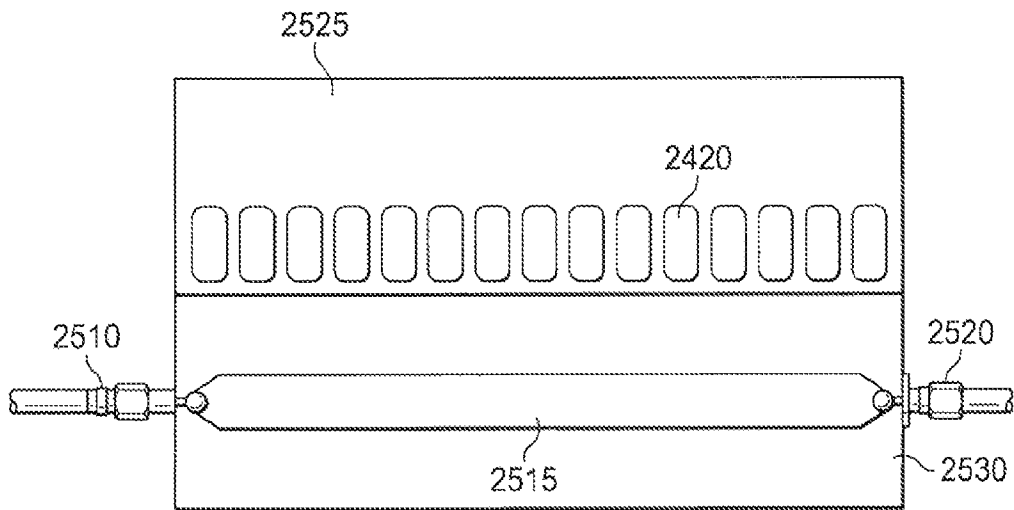

FIG. 25

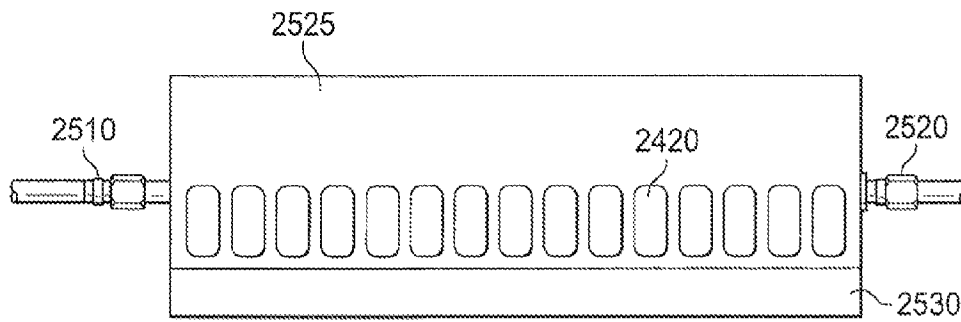

FIG. 26

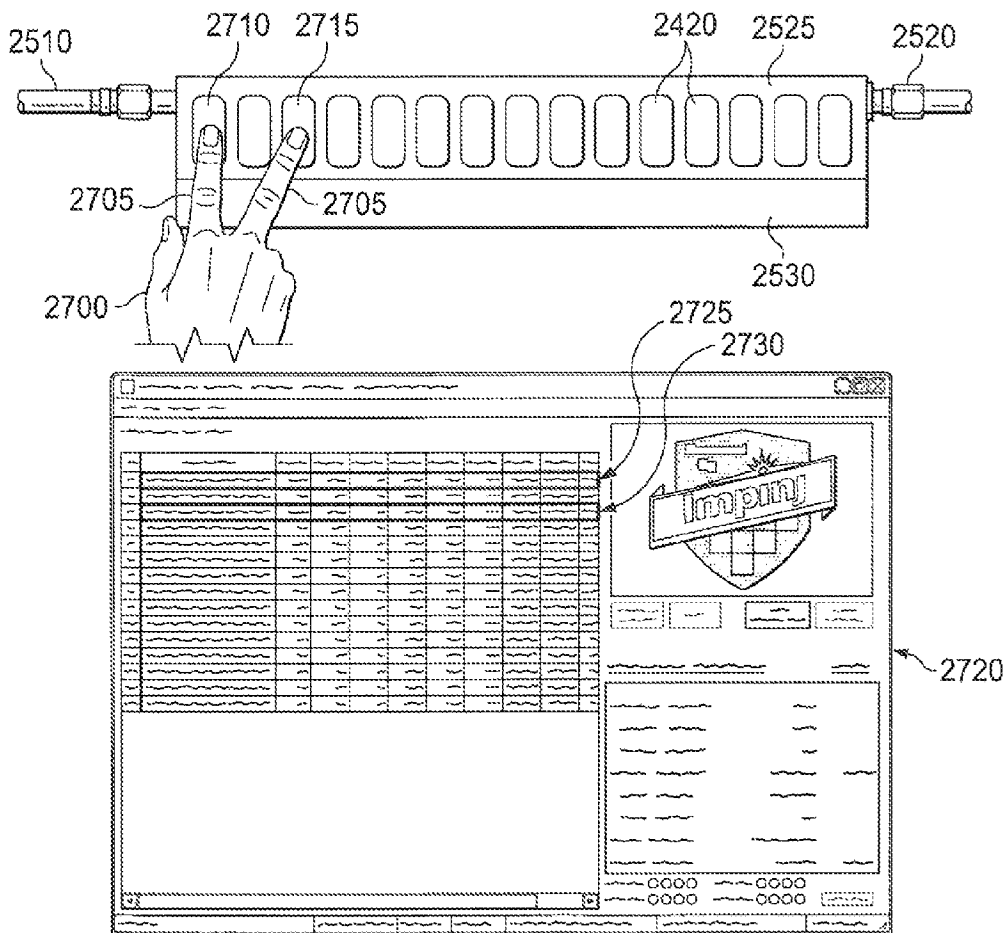

FIG. 27

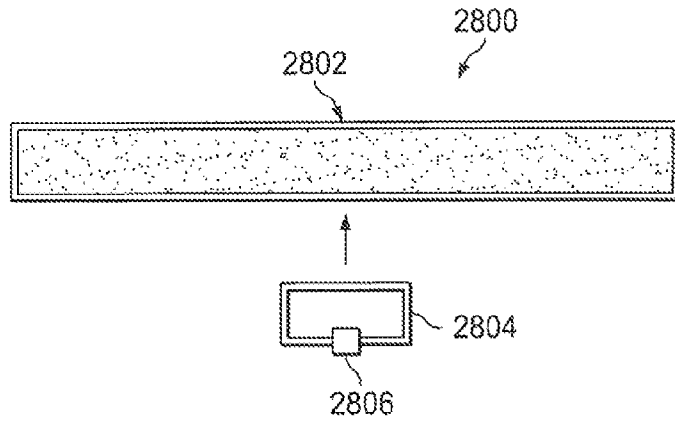

FIG. 28

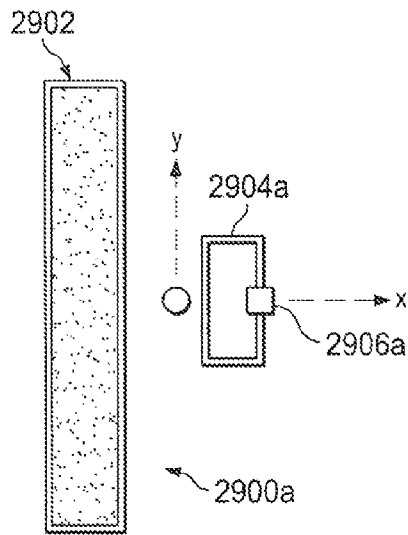

FIG. 29a

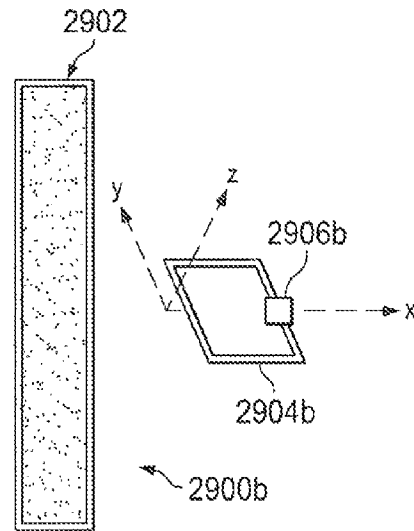

FIG. 29b

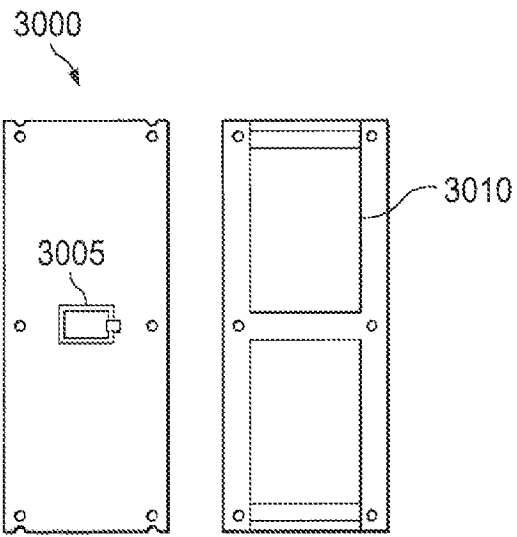

FIG. 30a

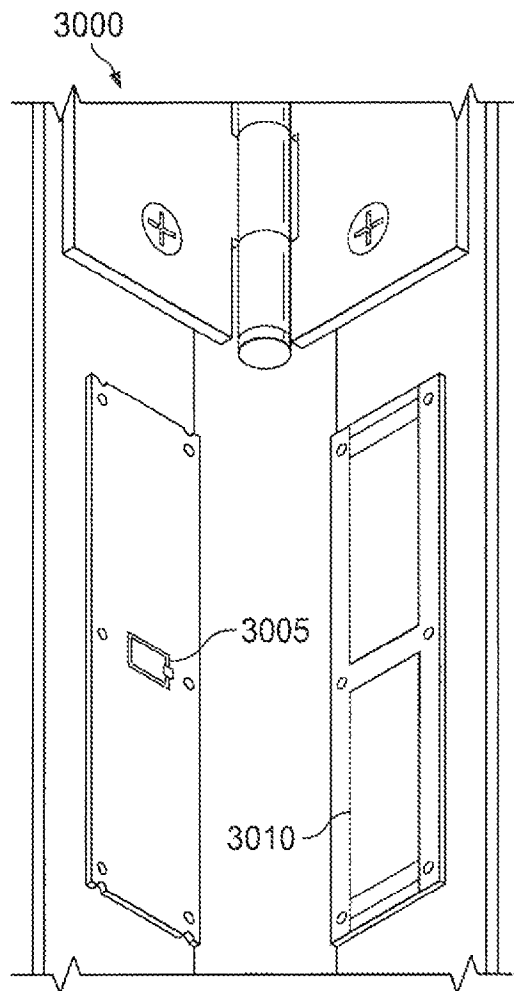

FIG. 30b

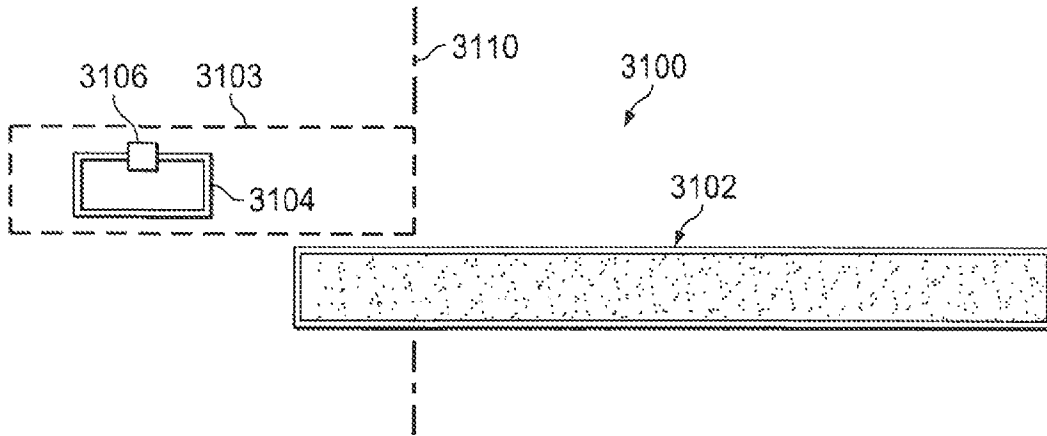

FIG. 31a

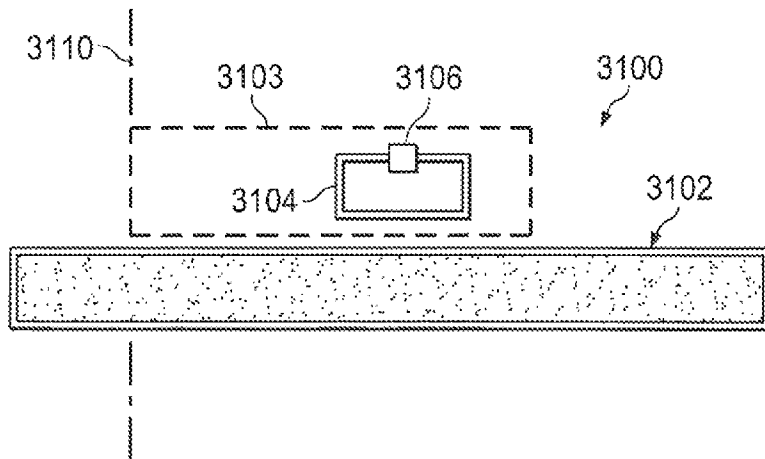

FIG. 31b

1

SYSTEMS AND METHODS FOR RFID-ENABLED DISPENSER

I. ORIGIN OF THE INVENTION

The invention described herein was made employees of the United States Government and may be manufactured and used by or for the Government of the United States of America for governmental purposes without the payment of any royalties thereon or therefor.

II. FIELD OF THE DISCLOSURE

The present disclosure relates generally to radio frequency identification (RFID) systems, methods, and apparatuses. More particularly, the disclosure relates to systems, methods and apparatuses for a RFID-enabled dispenser.

III. SUMMARY

The embodiments described herein relate to applications of radio frequency identification (RFID) technology to monitor and manage inventory, including RFID-enabled dispensers, which permit tracking of small items, such as pills or grains, for which attachment of individual RFID sensors is impractical. Other inventory management applications include level detectors, in which the level of material filling a volume is sensed. Sensor applications include a distributed pressure sensor.

Methods, apparatuses and systems for RFID-enabled information collection are disclosed, including a system comprising an enclosure, a collector coupled to the enclosure, an interrogator, a processor, and one or more RFID field sensors, each having an individual identification, disposed within the enclosure. The interrogator is configured to transmit an incident signal to the collector, causing the collector to generate an electromagnetic field within the enclosure. The electromagnetic field is affected by one or more influences. One or more of the RFID sensors respond to the electromagnetic field by transmitting, via the collector, a reflected signal to the interrogator, the reflected signals containing the individual identifications of the responding RFID sensors. The interrogator is configured to receive the reflected signals, measure one or more returned signal strength indications ("RSSI") of the reflected signals and send the RSSI measurements and the corresponding identification of the responding REID sensors as information to the processor. The processor is configured to analyze the information to determine one or more facts about the influences.

Another embodiment disclosed is a RFID-enabled dispenser including a parallel plate waveguide comprising a plurality of conductive layers and a dispensing container placed within the waveguide. The dispensing container has an opening for dispensing items and a dispensing element for moving the items to be dispensed through the opening. The dispensing container also has a traveler for moving items within the dispensing container towards the opening, the traveler moving in response to force exerted by a forcing element. An antenna, coupled to the waveguide, is configured to generate an electromagnetic field within the waveguide in response to an incident signal sent from an interrogator, the electromagnetic field being affected by one or more influences. One or more RFID field sensors are placed inside the waveguide at intervals along the axial direction of the waveguide. Each RFID field sensor has an identification and is capable of responding to the electromagnetic field by transmitting, via the antenna, reflected signals to the interrogator,

2

the reflected signals containing the identification of the responding RFID field sensors. The interrogator is further configured to receive the reflected signals, measure one or more returned signal strength indications (RSSI) of the reflected signals and send the RSSI measurements and the corresponding identification of the responding RFID field sensors as inputs to the processor for use by the processor in making at least one determination about the one or more influences.

Another embodiment disclosed is a RFID-enabled dispenser comprising a holder and a dispensing container placed within the holder. The holder has an elongated structure with multiple antenna cells, each antenna cell containing an RFID circuit having a unique identification. Each antenna cell is of sufficient size for resonance, so that the antenna cell may tune to an operating frequency of its RFID circuit. The dispensing container has an opening for dispensing items from the dispensing container and a traveler for moving items within the dispensing container towards the opening. The traveler moves in response to force exerted by a forcing element. The traveler includes a dielectric body (which may include optional metallic or conductive components), the position of the traveler and its dielectric body activating a particular antenna cell in which the traveler is positioned and enabling the RFID circuit within the particular antenna cell to receive an incident signal from an interrogator and to send a response to the interrogator. The interrogator is configured to receive the response, measure one or more returned signal strength indications ("RSSI") of the response and send the RSSI measurements and the corresponding identification of the responding RFID field sensors as information to a processor. The processor is configured to use the information received from the interrogator to determine the position of the traveler. The items may comprise packages of one or more objects. In one embodiment, for example, the items may be disk-shaped and include segmented packaging for separating two or more of the objects.

Another embodiment described herein is an apparatus for a radio frequency identification (RFID)-enabled pressure sensing glove, including a glove having a palm side, a back side, and at least one digit. The glove includes a plurality of ring elements, each on a foam pad, the foam pads being attached to the palm side of the glove on the at least one digit and palm, each ring element including a RFID sensor attached to a near field loop, and a microstrip patch antenna on the back side of the glove. The microstrip patch antenna is connected to one or more microstrip lines coupling the antenna to the ring elements, the microstrip lines each terminating in a load element near the end of each digit, which prevents development of a standing wave pattern. Pressure on a ring element activates its RFID sensor allowing the RFID sensor to transmit a signal to an interrogator.

Yet another embodiment described herein is an apparatus for a radio frequency identification (RFID)-enabled pressure sensitive keypad. The RFID-enabled keypad includes a plurality of RFID tags bonded to an operatively insulating and compressible substrate and an operably planar open waveguide, the waveguide being bonded on an operatively insulating dielectric base and in communication with a collector. A load is connected to one end of the waveguide. The substrate bearing the RFID tags is positioned over the base and adjacent to a conductor of the waveguide, one or more of the RFID tags being energized when operably depressed to send signals via the collector to an interrogator, an electromagnetic coupling being enabled between the waveguide and the depressed RFID tag.

Another embodiment described herein is a method of determining one or more influences on a generated electromagnetic field. The method comprises the step of transmitting an incident signal from an interrogator to a collector coupled to a waveguide causing the collector to generate the electromagnetic field along the waveguide. The electromagnetic field may be affected by the one or more influences. The waveguide contains one or more radio frequency identification (RFID) sensors, each RFID sensor having an individual assigned identification. The method further comprises the steps of transmitting a reflected signal from one or more of the RFID sensors via the collector to the interrogator in response to the electromagnetic field, the reflected signal including the individual identification from the responding RFID sensors, measuring one or more returned signal strength indications (“RSSI”) of the reflected signal by the interrogator, and sending the RSSI measurements and the corresponding identification of the responding RFID field sensors from the interrogator to a processor. The method further comprises the step of analyzing the RSSI measurements and identifications by the processor to make determinations about the one or more influences.

Another embodiment disclosed is an apparatus for use as a switch, comprising at least one RFID tag, each RFID tag comprising an antenna element and an RFID integrated circuit, at least one source element, and at least one lever arm. Each lever arm is connected to one of the RFID tags, and each lever arm is capable of two positions. One of the positions places the lever arm and the RFID tag connected thereto into alignment with the source element.

Another embodiment disclosed is a system for radio frequency identification (RFID)-enabled information collection comprising one or more antenna cells comprising ring elements, each ring element including a conductive ring connected to a RFID integrated circuit, at least one source element, an interrogator capable of transmitting a signal to the source element and a processor in communication with the interrogator. At least one of the conductive rings is capable of coupling to its source element when the conductive ring is in a first position, energizing the RFID circuit associated with the conductive ring to respond to the interrogator’s signal. The processor is capable of deriving information regarding the positions and orientations of the one or ring elements relative to the one or more sources. The source element may be an antenna element, or in another embodiment the source element may be an open waveguide, such that the ring element can couple to the waveguide structure when it is in the proper position and/or orientation. The conductive ring and the source element may be placed on door components such that the conductive ring couples to the source element only when the door is in a first position.

Other aspects and advantages of the embodiments described herein will become apparent from the following description and appended claims, taken in conjunction with the accompanying drawings, illustrating the principles of the embodiments by way of example only.

IV. BRIEF DESCRIPTION OF THE DRAWINGS

FIG. 1 is a schematic diagram, in accordance with one or more embodiments described herein, of an RFID-enabled enclosure in the form of a cavity comprising a container.

FIG. 2 is a schematic diagram in accordance with one or more embodiments described herein in which an RFID-enabled enclosure is in the form of a cavity comprising a container and a collector comprising an antenna lid on the container.

FIG. 3 is a schematic diagram in accordance with one or more embodiments described herein of an RFID-enabled container with RFID field sensors in the form of an array of RFID integrated circuits.

FIG. 4 depicts a schematic diagram in accordance with one or more embodiments described herein of an RFID-enabled cavity filled with foam and bounded by a conductive fabric exterior.

FIG. 5 depicts a schematic diagram in accordance with one or more embodiments described herein of an RFID-enabled conductive cavity in which a conductive, flexible diaphragm applies pressure to and reduces the volume of the RFID-enabled conductive cavity.

FIG. 6 is a schematic diagram of an RFID-enabled item dispenser having multiple items in each dispensed disc, in accordance with one or more embodiments described herein.

FIG. 7 depicts a schematic diagram in accordance with one or more embodiments described herein of an RFID-enabled container or dispenser having conductive walls and a conductive center post.

FIG. 8a is an illustration of an RFID-enabled container made in accordance with one or more embodiments described herein. FIGS. 8b-8e are illustrations depicting additional details of a capacitively-fed planar inverted F antenna (“PIFA”), such as the one used for the RFID-enabled container of in FIG. 8a.

FIG. 9 is a graph depicting the results of four tests performed using the embodiment of FIG. 8a.

FIG. 10 is a schematic diagram of a spring-operated item dispenser.

FIG. 11 is a schematic diagram of the item dispenser of FIG. 10, modified to be an RFID-enabled item dispenser having an enclosure in the form of a parallel plate waveguide, in accordance with one or more embodiments described herein.

FIG. 12 is a schematic diagram of an RFID-enabled item dispenser having an enclosure in the form of a coaxial waveguide, in accordance with one or more embodiments described herein.

FIG. 13 is a schematic diagram of an RFID-enabled item dispenser in accordance with one or more embodiments described herein, wherein a traveler contains a dielectric body within.

FIG. 14 is a schematic diagram of an embodiment of the holder cells of FIG. 13.

FIG. 15 is a schematic diagram of another embodiment of the holder cells of FIG. 13, illustrated with a traveler, having a conductive pattern, within the holder cell.

FIG. 16 is a schematic diagram of an RFID-enabled item dispenser in accordance with one or more embodiments described herein, having holder cells on two sides of the dispenser, with an electromagnetic short on one side of the holder cells.

FIG. 17 is a schematic diagram of an RFID-enabled item dispenser with the dispensing component outside of the holder in accordance with one or more embodiments described herein.

FIG. 18 is a schematic diagram of an interrogation of an RFID-enabled item dispenser in accordance with one or more embodiments described herein.

FIG. 19a is a schematic diagram of an RFID-enabled item dispenser, depicting an end view cross section of a dispenser unit, in accordance with one or more embodiments described herein.

FIG. 19b is a schematic diagram of an RFID-enabled item dispenser in which a top conductive layer comprises a top circuit having one or more ring microstrip antenna cells, in accordance with one or more embodiments described herein.

FIG. 19c is a schematic diagram of an RFID-enabled item dispenser having a traveler conductive layer beneath a traveler dielectric layer, in accordance with one or more embodiments described herein.

FIG. 19d is a schematic diagram of an RFID-enabled item dispenser in accordance with one or more embodiments described herein, in which a traveler conductive surface provides a folded ground plane with a short.

FIG. 19e is a schematic diagram of an RFID-enabled item dispenser having a circular cross section and ring microstrip antennas, in accordance with one or more embodiments described herein.

FIG. 19f is a schematic diagram of an RFID-enabled item dispenser having a top conductive layer of one or more microstrip antennas wrapped around a cylinder with a circular cross-section, in accordance with one or more embodiments described herein.

FIG. 20 is a schematic diagram of the palm side of an RFID-enabled pressure sensor glove in accordance with one or more embodiments described herein.

FIG. 21 is a schematic diagram of the back (top) side of an RFID-enabled pressure sensor glove in accordance with one or more embodiments described herein.

FIG. 22 is a schematic diagram of a robot with an RFID-enabled pressure sensor glove in accordance with one or more embodiments described herein.

FIGS. 23a-23e depict alternate embodiments each representative of a finger on the RFID-enabled pressure sensor glove of FIGS. 20-22.

FIG. 24 is a diagram of an RFID tag in accordance with one or more embodiments described herein.

FIG. 25 is a diagram of components of another embodiment described herein.

FIG. 26 is a diagram of the proper placement of the components depicted in FIG. 25.

FIG. 27 illustrates the embodiments of FIGS. 24-26 combined with a screen shot of software displaying the results of a test of a prototype.

FIG. 28 depicts a ring sensor that may be used in various embodiments described herein.

FIG. 29a depicts a ring sensor positioned to couple with a source element in accordance with one or more embodiments described herein.

FIG. 29b depicts a ring sensor, which may be used in one or more embodiments described herein, positioned so as to not couple with the source element.

FIGS. 30a and 30b depict a ring sensor used as a sensor to detect whether a hinged door is in an open or closed position in accordance with one or more embodiments described herein.

FIGS. 31a and 31b depict a ring sensor, which may be used in one or more embodiments described herein, configured to be used as a switch.

While the appended claims are subject to various modifications and alternative forms, specific embodiments thereof are shown by way of example in the drawings and the accompanying detailed description. It should be understood, however, that the drawings and detailed description are not intended to limit the appended claims to the particular embodiments described herein. This description and disclosure is instead intended to cover all modifications, equivalents, and alternatives falling within the scope of the present invention as defined by the appended claims.

V. DETAILED DESCRIPTION

The drawings are not necessarily to scale and certain features may be shown exaggerated in scale or in somewhat

generalized or schematic form in the interest of clarity and conciseness. In the description which follows, like parts may be marked throughout the specification and drawings with the same reference numerals. The foregoing detailed description is provided for a more complete understanding of the accompanying drawings. It should be understood, however, that the embodiments described herein are not limited to the precise arrangements and configurations shown. Although the design and use of one or more embodiments are discussed in detail below, it should be appreciated that the present description provides many inventive concepts that may be embodied in a wide variety of contexts. The specific aspects and embodiments discussed herein are merely illustrative of ways to make and use the embodiments described, and do not limit the scope of the appended claims. It would be impossible or impractical to include all of the possible embodiments and contexts of the appended claims in this description. Upon reading this description, alternative embodiments within the scope of the appended claims will be apparent to persons of ordinary skill in the art.

FIG. 1 depicts one or more embodiments described herein comprising two or more RFID field sensors 100, a collector 110, a coupling 120, and an enclosure 130 comprising an enclosing surface or volume 125 defining a resonator (such as a waveguide or a cavity, as depicted in FIG. 1) or other enclosure 130. The collector 110 funnels, via the coupling 120, electromagnetic energy creating an electromagnetic field 135 into the enclosure 130. The electromagnetic field 135 is distributed throughout the enclosure 130 according to Maxwell's equations. The distribution of the electromagnetic field 135 within the enclosure 130 may be affected by one or more conditions referred to herein as influences 140. The influences 140 may be connected to substances such as materials or liquids within the enclosure. The RFID field sensors 100 are within and preferably distributed throughout the enclosure 130. An RFID reference sensor 115 is typically located within or adjacent to the collector 110.

Continuing to refer to FIG. 1, an interrogator 145 sends an incident signal 150, to the collector 110, which, as described above, generates the electromagnetic field 135 within the enclosure 130. The RFID field sensors 100 and/or the RFID reference sensor 115, each having their own identification information, respond to the electromagnetic field 135 by sending reflected signals 155 with the identification of the responding RFID field sensor 100 or RFID reference sensor 115, to the interrogator 145 via the coupling 120 and collector 110. The incident signal 150 and reflected signals 155 comprise radio frequency (RF) signals. The interrogator 145 measures returned signal strength indications ("RSSI") of the reflected signals 155, the RSSI measurements preferably including the strength and the phase of the reflected signals 155. A processor (not separately depicted in FIG. 1) residing in, or connected to, the interrogator 145 determines the characteristics of the influences 140 based on the reflected signals 155 from the one or more RFID field sensors 100 and/or the RFID reference sensor 115. Measurements of the reflected signal 155 from the RFID reference sensor 115 may be compared to measurements of the reflected signals 155 from the responding RFID field sensors 100 to identify and remove extraneous variations not related to the influences on the electromagnetic field.

In alternate embodiments, measurements of the electromagnetic field 135 may be made by the RFID field sensors 100 and reference sensor 115 and transmitted to the interrogator.

Although the cross-section of the enclosing surface 125 in FIG. 1 is depicted as a rectangle or box, the enclosing surface

125 may be of any shape convenient to the application. Although RF signals described above are commonly transmitted at 900 MHz UHF, different frequency bands may be used with the embodiments described herein. The RFID sensors **100**, **115** used may be for example RFID integrated circuit sensors, Surface Acoustic Wave (SAW) RFID sensors or any other RFID sensor suitable for the purpose.

FIG. 2 depicts one or more embodiments of the present disclosure described herein in which the collector comprises a lid antenna **200** on a cylindrical enclosure **210**, which defines a cavity **215** (or waveguide) and which is at least partially filled with fill material **220** to a fill level **222**. The amount of fill material **220** and corresponding fill level **222** may vary over time. An interrogator **230** sends an incident signal (not depicted) to a coupler (not depicted in FIG. 2) which transfers the incident signal into the cavity **215** so as to establish an electromagnetic field distribution therein. The coupler might comprise, for example, an aperture shared between the lid antenna **200** and the cavity **215**, or the coupler might comprise a probe from the lid antenna **200** that protrudes into the cavity **215**.

Continuing to refer to FIG. 2, one or more RFID field sensors **225** having identification information are positioned within the enclosure **210**. Each RFID field sensor **225** may be, for example, an RFID integrated circuit, a SAW RFID or any other suitable RFID sensor. The RFID field sensors **225** that respond to the electromagnetic field send their identification information in reflected signals to the interrogator **230** via the lid antenna **200**. The fill material **220** and fill level **222** comprise influences affecting the electromagnetic field. The interrogator **230** receives the reflected signals, measures the RSSI of the reflected signals, and sends the RSSI measurements with the corresponding identification of the responding RFID field sensors **225** to a processor **235**, which may be within or connected to or otherwise in communication with the interrogator **230**. The processor **235** determines the type of fill material and/or the fill level based on the information received from the interrogator **230**. In FIG. 2, the processor **235** is depicted within the interrogator **230**, but the processor **235** and interrogator **230** could be separate and in communication with each other. One or more reference RFID field sensors (not depicted in FIG. 2) may be disposed on the exterior of the enclosure **210** or on or within the lid antenna **200**.

In an alternative embodiment, the RFID field sensors **225** measure or estimate the received power and/or phase of the electromagnetic field and transmit the measurements to the interrogator **230**, along with the corresponding identification numbers of the responding RFID field sensors **225**.

For embodiments of the present disclosure in which the enclosure **210** forms a hollow waveguide or cavity, propagation of the electromagnetic field down the cavity or waveguide depends on wavelength, so the cavity or waveguide may need to be of a sufficient size such that the signal is above a "cutoff" frequency. In one or more embodiments, the cavity or waveguide is below cutoff when empty but is above cutoff during the presence of an influence. For example, the dielectric property of a fill material can shift the waveguide cutoff frequency below the RFID operating frequency to enable one or more RFID field sensors. In other embodiments, metamaterials are employed in the cavity or waveguide to lower the cutoff frequency as an alternative to increasing the waveguide or cavity size. In other embodiments, a second conductor, such as an inner conductor, which may be in a coaxial configuration or offset, is used so as to avoid size restrictions and the associated cutoff frequency. In embodiments of the present disclosure having an outer conductor and an inner conductor, the electromagnetic field will

be generated between the outer conductor and the inner conductor. In such a configuration, the waveguide is capable of propagating a wave that is substantially transverse electromagnetic (TEM). Transverse waves are waves where the disturbance is perpendicular to the direction of propagation. If one throws a stone into a lake, a transverse wave is created: the waves move outward from the point the stone entered the water, but to create the "wave," the water in the lake moves up and down. In TEM waves, the electric and magnetic field disturbances are perpendicular both to each other and to the direction of the propagation of the wave. The outer conductor and the inner conductor may have various shapes and/or cross sections. The inner conductor may be centered within the outer conductor or may be offset.

FIG. 3 depicts an exploded diagram of one or more embodiments of an RFID-enabled information collection system comprising a thin transmission line **300** attached to a non-conductive enclosure **315**, with one or more RFID tags such as RFID integrated circuit chips **310** attached in parallel fashion along the transmission line **300**. An antenna **320** attached to the enclosure **315** serves as the collector. The antenna **320** is connected to the transmission line **300**. An interrogator **340** sends an incident signal to the antenna **320**, which launches an electromagnetic field along the transmission line **300**. Similar to conventional RFID tags, the thin RFID transmission line **300** can be printed on a thin, flexible plastic layer that attaches to the inside or outside of the enclosure **315** with an adhesive.

In the embodiment depicted in FIG. 3, the enclosure **315** is nonconductive and sufficiently thin-walled, such that the electromagnetic field along the transmission line **300** is influenced by fill material **330** and its fill level **325** inside the enclosure **315**. Each RFID integrated circuit chip **310** responding to the electromagnetic field sends its identification with a reflected signal to the interrogator **340**, which measures the RSSI, such as the strength and or phase of the reflected signals. In alternative embodiments, the RFID integrated circuit chips **310** on the transmission line **300** may measure the power of the electromagnetic field and transmit the measurements of electromagnetic field, along with the identification of each RFID integrated circuit chip **310** performing the measurement, to the interrogator **340**.

The interrogator **340** includes or is connected to a processor **345**, which uses the RSSI measurements with algorithms running on the processor **345** to determine the fill level **325**, distribution, permittivity, or conductivity of one or more fill materials **330** in the enclosure **315**. The algorithms can be determined by empirical methods, by modeling, or by solving the inverse problem, a process known to those skilled in the art in which the field solutions are determined based on an estimate of the fill level **325** and/or material, the results are compared to the measured results, and a nonlinear global optimizer is used to refine the best estimate of the fill level and/or material in order to minimize the difference between the measured response and the simulated response.

In one or more embodiments, the fill material **330** may be a liquid that effectively shorts the transmission line **300**, thus prohibiting response from one or more of the RFID integrated circuit chips **310** that are positioned below the fill level **325**.

If the fill material **330** comprises one of two or more similar substances with similar electrical properties, such as cornflakes and oatmeal, the processor **345** may be able to tell the fill level but not distinguish between the similar substances. If the substances are different, such as liquid versus oatmeal or gravel versus oatmeal, the processor **345** may be able to distinguish the type of material **330** as well as the fill level **325** and/or volume.

FIG. 4 depicts a schematic diagram of another embodiment described herein in which a cavity 405, at least partially filled with foam 400, is formed within a conductive fabric boundary 410. A fabric antenna 420 on the outside of the conductive fabric boundary 410 functions as a collector. An interrogator 430 sends an incident signal (not depicted in FIG. 4) to an antenna 420, generating an electromagnetic field in the cavity 405 with a coupling in the form of a cavity feed probe or aperture (not depicted in FIG. 4). The interrogator 430 receives reflected signals (not depicted in FIG. 4) containing identification information from one or more RFID integrated circuits 435 positioned within the cavity 405 and responding to the electromagnetic field. One or more depressions 445 in the cavity 405 acts as an influence on the electromagnetic field. The interrogator 430 measures the RSSI of the reflected signals and sends the RSSI measurements and the corresponding identification of the RFID integrated circuits 435 to a processor 440, within or in communication with the interrogator 430. The processor 440 may analyze information received from the interrogator 430 to deduce the location, or locations, at which the cavity 405 has the depressions 445.

In an alternate embodiment of the system of FIG. 4, the RFID integrated circuits 435, as they respond to the electromagnetic field in the cavity 405, measure the electromagnetic field strength and/or phase and send the measurements with their corresponding identification in response to the interrogator 430.

In yet another alternate embodiment of the present disclosure depicted in FIG. 4, a conductive layer 402 is formed by a conductive paint on the boundary 410, which comprises an inflatable structure. The conductive layer 402 of paint is continuous and contiguous for many applications, but some embodiments might allow for use of patterns of conductive paint. Fill material within the cavity 405 created by the inflatable structure comprises one or more gases. The temperature and pressure of the gas or gases exert an influence on the flexible conductive boundary 410 of the cavity 405 and thus affect an electromagnetic field distribution (not specifically depicted in FIG. 4 but represented in general previously as electromagnetic field 135 in FIG. 1) within the cavity 405, the electromagnetic field being generated by the antenna 420 in response to a signal from the interrogator. RFID integrated circuits 435 within the cavity 405 respond to the electromagnetic field and transmit the identification of the responding RFID integrated circuit(s) 435 in reflected signals to the interrogator 430, which measures RSSI of the reflected signals and sends the measurements to the processor 440. Alternatively, the strength and phase of the electromagnetic field is measured by the RFID integrated circuits 435, which transmit the measurements and the specific identification of each of the responding RFID integrated circuits 435 to the interrogator 430. The processor 440 in communication with the interrogator 430 can use the information received from the interrogator 430 to determine the volume of the gas or gases within the cavity 405, thus permitting solution for the pressure, assuming the temperature is known. If there is a depression 445 of the boundary 410, the depression 445 would act as an influence on the electromagnetic field and facts about the extent of the depression 445 could be determined by the processor 440 in analyzing the information received from the interrogator 430.

FIG. 5 depicts one or more embodiments of the present disclosure in which a conductive, flexible diaphragm 510 applies pressure to and reduces the volume of a conductive cavity 520, resulting in changes in an electromagnetic field (not depicted) within the cavity 520. An antenna (not depicted in FIG. 5) which receives an incident signal from an interro-

gator 535 and couples electromagnetic energy to the cavity 520, creating the electromagnetic field within the cavity 520. The electromagnetic field distribution within the cavity 520 is sensed by one or more RFID field sensors 530 within the cavity 520. The RFID field sensors 530 may respond with reflected signals, including identification of the responding RFID field sensors 530 to the interrogator 535. The interrogator 535 measures the RSSI of the reflected signals and sends the measurements and the corresponding identification of the responding RFID field sensors 530 as information to a processor 540, within or connected to the interrogator 535. The processor 540 uses the information to determine the pressure applied by the diaphragm 510. The processor 540 in FIG. 5 is depicted as being within the interrogator 535, but the processor 540 could also be in communication with the interrogator without being within the interrogator 535.

In an alternate variation of the embodiment of FIG. 5, the cavity width is designed to render the cavity 520 close to the cutoff frequency on that dimension. The degree to which the diaphragm 510 is depressed determines how far below cutoff the antenna is as a function of frequency. The interrogator 535 may communicate over a number of channels, each channel distinguished by a range of frequencies. The interrogator 535 may hop between alternative channels using a frequency-hopping spread spectrum technique, as is well known in the art. An RSSI associated with each RFID field sensor 530 is reported for the various frequencies used by the interrogator 535, thus providing information from which the extent and location of the volume reduction of the cavity 520 can be estimated.

FIG. 6 will be discussed in more detail with FIG. 10 below.

Referring now to FIG. 7, an enclosure in the form of a container or dispenser 710, with a quantity of N embedded RFID tags 720, enables sensing of fill material 725 and fill level 730. The container or dispenser 710 has an inner conductor 715 and conductive container walls 705. (The inner conductor in FIG. 7 is depicted as coaxial, but in other embodiments, the inner conductor may be offset. The enclosure and inner conductor may have a variety of cross sectional shapes, such as circular, triangular, rectangular, trapezoidal, or any other polygonal-shape.) A lid antenna 735 serves as a coupling and, stimulated by an incident signal from an interrogator 745, excites a coaxial waveguide formed by the container 710 and inner conductor 715 and generates an electromagnetic wave (not specifically depicted in FIG. 7). The electromagnetic wave travels down the waveguide and provides power to the quantity N RFID tags 720. The powered RFID tags 720 respond by transmitting their identification to the interrogator 745, which measures the RSSI and provides information comprising the RSSI measurements and the corresponding identification of the responding RFID tags to a processor 740, within or connected to the interrogator 745. The processor 740 may be configured to use the information received from the interrogator 745 to determine facts regarding the fill material 725 and fill level 730. Preferably, a reference RFID tag (not depicted in FIG. 7) resides on top of or within the lid antenna 735, or is placed somewhere on the exterior of the container 710. The reference signal strength is compared with that from the other responding RFID tags 720 within the waveguide in order to remove variations due to the exterior propagation channel between the interrogator 745 and the lid antenna 735. Although the bottom of the container or dispenser 710 (opposite the lid) presents a short circuit of the coaxial structure in the embodiment depicted in FIG. 7, in general, a matched or other suitable load can be used to terminate the waveguide. Material can be removed through the lid antenna 735 or, alternatively, from a dispensing

11

mechanism (not shown). Alternatively, the lid and antenna can be on opposing ends of the container or dispenser **710**.

FIG. **8a** is a diagram of an exterior of a prototype of another embodiment described herein. In FIG. **8a**, a reference RFID tag **800** is fastened to the top of a container lid antenna **810**, which may comprise a capacitively-fed planar inverted F antenna (“PIFA”). A container wall **820** also serves as the outer conductor of a coaxial waveguide in FIG. **8a**. An inner conductor (not shown in FIG. **8a**) protrudes through the lid **810**, with isolation to prevent shorting to the lid **810**, and makes contact with a capacitive feed plate (not visible in FIG. **8a**). The container is filled with oatmeal, an example of a fill material. An interrogator (not visible in FIG. **8a**) sends an incident signal to the container lid antenna **810**, which generates an electromagnetic field. One or more field RFID tags (not depicted in FIG. **8a**), each having identification information, are placed on the internal side (not visible in FIG. **8a**) of the container outer conductive wall. The field RFID tags and the reference RFID tag **800** respond to the electromagnetic field, transmitting their identifications via the container lid antenna **810** to the interrogator. The interrogator measures the RSSI of the transmissions from the responding RFID tags and sends information including the measurements and the identification of the corresponding responding RFID tags for recordation and analysis by a processor (not visible in FIG. **5a**) within or in communication with the interrogator. The processor uses the recorded information to determine the quantity of oatmeal within the container **820**. Measurements of responses from the RFID reference tag **800** may be compared to measurements of responses from the responding field RFID tags to identify and remove extraneous variations not related to the influences on the electromagnetic field.

FIGS. **8b**, **8c**, **8d** and **8e** are diagrams showing additional details of a capacitively-fed planar inverted F antenna (“PIFA”), such as the antenna **810**, which could be used with embodiments described herein similar to the one pictured in FIG. **8a**. As depicted in FIG. **8b**, which provides a side view of the lid antenna, the lid antenna **810b** comprises a top plate **812**, a capacitive feed plate **813**, and a ground plate **814**, with a shorting strip **818** connecting the top plate **812** to the ground plate **814**. A feed post **815** attached to the capacitive feed plate **813** passes through an opening in the ground plate **814** and extends into the cavity of container **820e**. The feed post **815** is provided with an insulating standoff **816** from the body of the antenna **810b** at a clearance **817**. FIG. **8ec** provides a top view of the lid antenna **810b**, the top plate **812** and the shorting strip **818**.

FIG. **8d** and FIG. **8e** depict a patch lid antenna **810d** for a coaxial feed to an embodiment of the present disclosure comprising an RFID-enabled container **820e** with conductive walls **822e**. FIG. **8d** depicts a patch lid antenna **810d** with top and bottom layers **811d** and a feed post **815d** (which may also be called a “center post”). Optional threads **823** may be used to couple the lid antenna **810d** to the container **820e**. As depicted in FIG. **8e**, within the container **820e**, the feed post **815d** may be received by an insulating center post guide **824e** terminating in a conductive termination pad **825e**.

FIG. **9** depicts a graph of results of four different trials using the prototype of FIG. **8a**. As discussed above, for each trial, when the interrogator sends an incident signal to the container lid antenna **810**, the container lid antenna **810** receives an electromagnetic field. The interrogator measures RSSI from signals sent by RFID tag 1 and the reference tag and sends the measurements and identification of the corresponding RFID tags **800** to the processor. For each trial, the container **820** is removed from its position near the interrogator, emptied, and then filled with oatmeal to the level indi-

12

cated on the X-axis and a new trial is run. For this prototype, no attempt was made to maximize the power passed from the container lid antenna **810** to the container **820**, nor was any attempt made to equalize the sensitivity for different depths of fill material. Note how the trial lines vary somewhat at lower levels of cups of oatmeal, but the trial plots converge more closely as the cups of oatmeal increase. This convergence indicates that in these tests, this particular prototype is more accurate for higher fill levels than for lower level fills. However, the prototype serves the purpose of monitoring the fill level of a container **820** or dispenser. No batteries are required, and a single interrogator may remotely monitor a wide angular span of different containers or dispensers.

The embodiments described herein permit moderate to very fine resolution RFID tracking. A pill dispenser is an example of an application that would require fine resolution RFID tracking. Pills are typically too small for secure attachment of conventional RFID tags. In addition, accidental ingestion of RFID tags might not be beneficial for the patient. Furthermore, the tag cost would likely be prohibitive for attachment at the pill level.

Referring now to FIG. **10**, a schematic of a conventional dispenser, such as a pill dispenser, is shown. The items **1000** to be dispensed, which may be pills or other small items, from a dispenser **1005** are placed on top of or adjacent to a traveler **1010**, which compresses a spring **1020**. Items **1000** can be removed by a plunger **1025** which pushes one of the items **1000** through an opening **1030**. Spring tension in the compressed spring **1020** pushes the traveler **1010** and items **1000** forward to fill the vacated slot.

FIG. **6** is a schematic diagram depicting an RFID-enabled dispenser **600** that would be placed in a holder (not depicted in FIG. **6**) having one or more cells (not depicted in FIG. **6**). The RFID-enabled dispenser of FIG. **6** could be used as part of embodiments of the present disclosure like those depicted in FIGS. **11-19** herein, which are discussed in more detail below. The dispenser **600** may have a cylindrical structure **609**, with a circular cross-section **605**. A traveler **620** positioned by a spring **642** moves items **602**, which can be pushed by a plunger **644** (acting through a first opening **638**) through second opening **640**. The items **602** might comprise disks containing one or more individual objects **613**. The disc **602** depicted in the inset of FIG. **6** is segmented in a pie fashion, with an object **613** in each segment, but the item **602** may comprise any kind of convenient or desired type of packaging and may have shapes other than that of a disc. Items comprising a package containing a plurality of objects may be used with various embodiments of the RFID-enabled item dispenser of the present disclosure.

FIG. **11** is an exploded view of a modified version of the dispenser of FIG. **10**, wherein additional components are included to create an embodiment of the present disclosure, an RFID-enabled dispenser. As in FIG. **10**, the items **1000** to be dispensed are placed on top of or adjacent to a traveler **1130**, which compresses a spring **1120**. But the RFID-enabled dispenser **1102** of FIG. **11** has additional components which include a collector **1100**, such as an antenna, conductive layers **1105** to form a waveguide, such as a parallel plate waveguide **1110** (the parallel plates of the parallel plate waveguide comprising the conductive layers **1105**), and one or more RFID sensors **1115**. The RFID sensors **1115** are positioned on one or both sides of the parallel plate waveguide **1110** such that the ends establish electrical connection to the waveguide conductive layers **1105**. The conductive layers **1105** are typically solid but specialized applications may permit the use of patterned conductive layers. The RFID sensors **1115** could be placed intermittently or periodically

13

along the axial direction of the waveguide **1110**. An interrogator, not depicted in FIG. **11**, sends an incident signal to the collector **1100**, creating an electromagnetic field in the waveguide **1110**. The RFID sensors **1115** may respond to the electromagnetic field and send information including their identification as reflected signals to the interrogator. The interrogator measures the RSSI of the reflected signals and transmits information comprising the measurements and corresponding RFID sensor identification to a processor within or in communication with the interrogator. The processor records and/or analyzes the information received from the interrogator and may determine data concerning the items **1000** to be dispensed, such as the number of items already dispensed and/or the number of items remaining in the dispenser **1102** and possibly the type or material of the items **1000**. A first opening **1122** in one waveguide plate permits a plunger **1125** to move forward, and a second opening **1124** in the opposing waveguide plate permits items **1000** to be dispensed. Both the first opening **1122** and the second opening **1124** are sufficiently small to not disrupt continuity of the conductive waveguide **1110**. Alternatively, the first and second openings **1122**, **1124** may be located on the two sides orthogonal to the conductive waveguide plates, in which case an RFID sensor **1115** would be positioned so as not to interfere with the plunger **1125** or block the dispenser opening. As an alternative to a plunger **1125**, other dispensing mechanisms could be used to dispense items from the dispenser **1102**.

In a variation of the embodiment of FIG. **11**, the traveler **1130** may be modified from a conventional form to have one or more conductive surfaces, or to be predominantly conductive, so as to present an electromagnetic short to the waveguide **1110**. The position of the modified traveler **1130**, and hence the short, affects the wave pattern of the electromagnetic field and hence the RSSI, and possibly phase measurements, from each of the one or more RFID sensors **1115**. For example, the one or more conductive surfaces could short one of the adjacent RFID sensors **1115**. Alternatively, the one or more conductive surfaces could enable one of the RFID sensors **1115** by establishing the proper impedance presented by the RFID sensor **1115** to the waveguide. The processor, upon receiving the information from the interrogator, determines the quantity of the items **1000** remaining in the RFID-enabled dispenser **1102**, and possibly the type or material of the items **1000**.

In another version of the embodiment of FIG. **11**, an RFID sensor **1115** is embedded into the traveler **1130** such that the traveler **1130** absorbs incident energy from the incident signal, providing a different type of load to the waveguide **1110** and an RSSI value (and possibly phase) corresponding to the terminal end of the waveguide **1110**. The position of the traveler **1130** would be determined from RSSI measurements made by the interrogator from signals carrying identification information sent by the responding RFID sensors **1115** to the interrogator. (Alternatively, in some embodiments, the RFID sensors **1115** may measure an electromagnetic field created by the configuration of the embodiment and transmit the RSSI measurements to the interrogator.) In another embodiment, the traveler **1130** is designed to present a predetermined, but arbitrary, electromagnetic load.

FIG. **12** depicts one or more embodiments of the present disclosure in the form of a dispenser **1202** in which the collector **1200** provides an input signal to a spring end of the waveguide **1210** (on the opposite side compared to FIG. **11**). The waveguide of FIG. **12** is a type of coaxial waveguide **1210** with the spring **1220** serving as a center conductor and exerting a force to traveler **1230**.

14

In a variation of the embodiment of FIG. **12**, the surrounding structure constitutes a parallel plate waveguide, while in another version the structure constitutes a fully enclosed conductive cylinder **1205**, of arbitrary shaped cross-section. For the parallel plate embodiment, one or more RFID sensors (not depicted in FIG. **12**) having individual identification information would be positioned along one or both gaps between the parallel plates. For the fully enclosed cylinder embodiment, the RFID sensors would be positioned in the internal volume or at the entry/exit plane of the waveguide.

In each version of the embodiment of FIG. **12**, an interrogator (not depicted) sends an incident signal to the collector **1200**, which generates an electromagnetic field. The RFID sensors which respond to the electromagnetic field send their identification information via the collector **1200** to the interrogator, which measures the RSSI and sends the measurements and corresponding identification information to a processor, within or in communication with the interrogator, for analysis. (Alternatively, the RFID sensors make measurements of the electromagnetic field and send the measurements and the responding RFID sensors' identification as reflected signals via the collector **1200** to the interrogator.) The processor uses the measurements and sensor identification information to determine the amount or type of items within the dispenser and/or the number of items which have been dispensed.

FIG. **13** depicts a cross-section of a fine resolution RFID dispenser assembly **1300** in accordance with another embodiment described herein. In FIG. **13**, a dispenser **1302**, with items **1325** to be dispensed within, is placed within a holder **1305**, which comprises an elongated structure with multiple holder cells **1310**, each holder cell **1310** containing an RFID circuit **1315** with an individual identification. The holder cells may comprise but are not limited to parallel plate cells. A plunger **1335**, acting through a first opening **1338**, pushes an item **1325** to be dispensed through a second opening **1340**. A traveler **1320** contains a dielectric body **1330** within and is connected to a spring **1345**, operating similarly as in FIGS. **11** and **12**. The position of the traveler **1320** is determined by the number of items **1325** remaining within the dispenser **1300**. The position of the traveler **1320** and its dielectric body **1330** enables one of the RFID holder cells **1316** to be energized in that it receives signals from an interrogator (not depicted) and responds to the signals. The interrogator and a processor within or in communication with the interrogator, upon receiving the unique ID code of the responding RFID circuit in the energized RFID holder cell **1316**, are able to deduce the number of items **1325** remaining within the dispenser. (In alternate embodiments, all holder cells except one could be energized by an appropriate design, and the number of items remaining in the dispenser could be deduced by the interrogator and an appropriately programmed processor by determining the identity and thus the location of the non-responding holder cell).

Details of the holder cells of FIG. **13** are provided in FIG. **14**. Each holder cell **1310** comprises a top floor **1410** and bottom floor (not visible in FIG. **14**), each with a corresponding conductive pattern **1425**, **1430**. The top and bottom floor conductive patterns **1425**, **1430** may be identical. The interior sections **1440** of the floors are hollow in order to support the dispenser **1302** body (not depicted in FIG. **14**).

FIG. **15** is a schematic diagram depicting a holder cell **1310** and a resulting conductive pattern **1500** from the traveler **1320** when the traveler **1320** moves within the structure of a holder cell **1310**, in accordance with one or more embodiments described herein. Referring back to FIG. **13**, note that the convergence of the dielectric body **1330** of the traveler

1320 with the conductive patterns **1425**, **1430** of the holder cell **1310** energizes an RFID circuit (not depicted in FIG. **15**) within the holder cell **1310**.

FIG. **16** depicts one or more embodiments of an RFID enabled dispenser **1600** in accordance with the present disclosure. Similar to the embodiment depicted in FIG. **13**, the dispenser **1600** comprises a dispensing chamber **1612**, with items **1625** to be dispensed within, placed within a holder **1605**. The holder **1605** comprises an elongated structure with multiple holder cells **1610**, each holder cell **1610** containing an RFID sensor **1615** with a unique identification. A plunger **1635** is designed to act through a first opening **1638** to push an item **1625** to be dispensed through a second opening **1640**. A traveler **1620** contains a dielectric body **1630** within and compresses a spring **1645**, operating similarly as in FIGS. **11-13**. The position of the traveler **1620** is determined by the number of items **1625** remaining within the dispenser **1600**. Unlike FIG. **13**, in FIG. **16**, an electromagnetic short **1650** on one end of the holder cells **1610** functions to reduce the physical size of the holder cell **1610** required for resonance, such as a quarter-wave patch antenna or a planar inverted-F antenna (PIFA). The position of the traveler **1620** and its dielectric body **1630** enables one of the holder cells **1610**, a RFID holder cell **1616** that is energized, to function as an operable antenna at the frequency of operation, and hence enables the RFID sensor in the energized holder cell **1616** to receive signals from an interrogator (not depicted) and to respond to the signals. The interrogator and a processor within it, upon receiving the unique ID code of the responding RFID sensors **1615**, are able to deduce the number of items **1625** remaining within the dispenser **1600**.

FIG. **17** depicts one or more embodiments of an RFID enabled dispenser **1700** in accordance with the present disclosure. In structure and operation, the embodiment in FIG. **17** is similar to that of FIGS. **13** and **16**. The dispenser assembly **1700** includes a dispensing chamber **1712**, with items **1725** to be dispensed, placed within a holder **1705**. The holder **1705** comprises an elongated structure with multiple holder cells **1710**, each holder cell containing an RFID sensor **1715** with a unique identification. A plunger **1735** is designed to act through a first opening **1738** to push an item **1725** to be dispensed through a second opening **1740**. A traveler **1720** contains a dielectric body **1730** within and compresses a spring **1745**, operating similarly as in FIGS. **11-13** and **16**. The position of the traveler **1720** is determined by the number of items **1725** remaining within the dispenser **1700**. As with the embodiment of FIG. **16**, an electromagnetic short **1750** on one end of the holder cells **1710** functions to reduce the physical size of the holder cell **1710** required for resonance, such as a quarter-wave patch antenna or a planar inverted-F antenna (PIFA). The position of the traveler **1720** and its dielectric body **1730** enables one of the holder cells **1710** to function as an operable antenna at the frequency of operation, and hence enables the RFID sensor in the energized cell to receive signals from an interrogator (not depicted) and to respond to the signals. In the embodiment of FIG. **17**, the dispensing chamber **1712** of the RFID enabled dispenser **1700** is separable from the holder **1705**, as depicted.

FIG. **18** illustrates another embodiment in which a remote RFID reader (also called an interrogator) **1800** interrogates an RFID-enabled dispenser **1805**, and only a single active RFID holder cell **1810**, determined by a traveler **1815** position, responds. A holder **1820** comprises a collection of holder cells **1825**, each of which may comprise any of a number of types of antennas, including but not limited to half-wave microstrip patches, quarter-wave patches, and PIFAs. Each holder cell **1825** contains an RFID sensor **1830**. When the

traveler **1815**, positioned by a spring **1816**, moves to the location of the representative holder cell **1810**, that holder cell **1810** is energized, that is, suitably tuned or enabled as an antenna to receive energy from the interrogator **1800**, transfer energy to the particular RFID sensor **1812** operatively connected to the energized holder cell **1810**, and re-radiate energy from the RFID sensor **1812** to the interrogator **1800**. When the traveler **1815** is not positioned within the location of the holder cell **1810**, holder cell **1810** is not conducive to transferring energy from the collector means to the RFID sensor **1812** associated with this particular holder cell. When the traveler **1815** is within the location of the holder cell **1810**, this particular holder cell **1810** activates and sends signals back to the interrogator **1800** for analysis by a processor (not separately depicted in FIG. **18**) within or in communication with the interrogator **1800**. Based on the RFID sensor **1812** that responds, the processor can determine the position of the traveler **1815** and hence the quantity of items **1835** remaining within the dispenser **1805** (or the quantity of items which have been dispensed). As with the embodiments of FIGS. **13** and **16**, a plunger **1845** acts through a first opening **1838** to push an item to be dispensed through a second opening **1840**.

To augment the effect of the traveler **1815** residing within the holder cell **1810**; i.e. to enhance the ability of the energized holder cell **1810** to couple energy to the RFID sensor **1812** that shares the same holder cell **1810** as the traveler **1815**, the structural body of traveler **1815** might include an enhanced coupler. Examples of possible enhanced couplers include but are not limited to a high dielectric body that tunes (1) the resonant frequency of the holder cell **1810** so as to be functioning as an antenna; (2) the impedance of the holder cell **1810** to match that of a collector; or (3) the resonance of the energized holder cell **1810** to affect the cavity impedance response of the holder cell **1810**. In another embodiment, the traveler **1815** might comprise a top conductive pattern and a bottom conductive pattern with an insulator in the middle. In yet another embodiment, the traveler **1815** might comprise a short between the top and bottom conductive patterns, in which the short tunes the holder cell **1810** as the traveler **1815** enters.

Communication protocols organize exchanges of information between devices. The response of the RFID sensors within the holder cells functioning as an antenna of FIG. **18** may follow such a communication protocol, with the interrogator also following the same protocol. One such protocol is the EPCglobal Class 1 Generation 2 protocol.

FIG. **19a** is a combined front and side view of another embodiment described herein in which an RFID-enabled item dispenser **1900** dispenses items **1902**. A first half **1906** of conductive cell patterns are formed on a first printed circuit board (a first PCB) **1905** and a second half **1908** of the conductive cell patterns are formed on an opposing (or "back") side (a second PCB) **1910** with a dispenser unit **1915** between the first and second PCBs **1905**, **1910**. Similar to previous embodiments described above, a traveler **1920** enables communications to and from an RFID circuit (not depicted in FIG. **19a**) within a particular cell **1931** of the holder cells **1930** formed by the first and second halves of the conductive patterns **1906**, **1908**. A top conductive pattern **1935** on the traveler **1920**, possibly in conjunction with a dielectric body, enables the particular cell **1931** hosting the traveler **1920** to receive and send RFID signals from/to the interrogator. (As the traveler changes position, other holder cells would become activated.)

Continuing to refer to FIG. **19a**, the conductive patterns **1906**, **1908** on the first and second PCB's **1905**, **1910** might be different; e.g., the first half of the conductive pattern **1906**,

on the first PCB, might be characterized with one or more empty regions, whereas the second half **1908** of the conductive pattern, on the second PCB **1910**, might be a single filled conductive region. In other embodiments, the conductive patterns **1906**, **1908** might be identical.

FIG. **19a** also depicts a dispenser door **1940** at the base of the dispenser **1900**. Although other embodiments discussed herein have indicated a spring that presents a force to propel the traveler **1920**, other mechanisms (called “forcing elements” herein) might be used to propel the traveler **1920**, such as (but not limited to) gravity (as depicted in FIG. **19a**), levers, masses placed above the traveler **1920** in the presence of gravity, or gears.

In a variation of the embodiment depicted in FIG. **19a**, the second PCB **1910** does not contain the second half of the conductive pattern **1908**. Instead, an additional conductive pattern is placed on the back side of the traveler **1920**. In various embodiments, the traveler may have a conductive pattern on one side and solid metal on the other or the traveler may have solid metal on one side and a dielectric on the other or both sides of the traveler may have conductive patterns. In one or more embodiments of the present disclosure, the traveler may have a side with a solid metal and one of the PCB’s may have a continuous ground plane. When the traveler rests in a holder cell functioning as an antenna, the traveler shorts out the holder cell, deactivating it and its operation as an antenna. As other holder cells are activated, the location of the de-activated holder cell provides the location of the traveler and thus discloses the number of items contained in the dispenser.

FIG. **19b** is a schematic diagram depicting one or more embodiments of the present disclosure in the form of an RFID-enabled item dispenser **1900b** in which a top conductive layer **1906b** comprises one or more ring microstrip antenna circuits **1901b**, each of which is attached to an RFID sensor **1915b**. As the terms are used with respect to FIGS. **19a-19f**, a “conductive layer” is not necessarily a solid conductive layer. The top conductive layer **1906b** is conductive in the sense that it includes the ring microstrip antenna circuits or other antenna pattern; it does not have to be a solid conductive layer. The ring microstrip antenna circuits **1901b** may be rectangular, as depicted in FIG. **19b**, circular, triangular or have some other configuration. The top conductive layer **1906b** is attached to a dielectric layer **1907b**. A traveler conductive layer **1935b** is parallel and adjacent to the dielectric layer **1907b**. When adjacent to one of the ring antenna circuits **1916b**, the traveler conductive layer **1935b** enables the adjacent ring microstrip antenna circuit **1916b**, with its RFID sensor, to send and receive signals to and from an interrogator (not depicted in FIG. **19b**) within a frequency band of operation. The traveler **1920b** in FIG. **19b** is propelled by a spring **1942b**, although other forcing elements might be used. As with similar embodiments of an RFID-enabled dispenser discussed herein, in FIG. **19b**, a plunger **1944b**, acting through a first opening **1938b**, pushes the item **1902b** to be dispensed through a second opening **1940b**.

FIG. **19c** depicts another embodiment of an RFID-enabled item dispenser **1900c**, in accordance with one or more embodiments described herein. The RFID-enabled item dispenser **1900c** is otherwise similar to the embodiment depicted in FIG. **19b**, but in which a traveler conductive layer **1935c** is inserted between the body of the traveler **1920c** and a traveler dielectric layer **1936c**. Similar to FIG. **19b**, in FIG. **19c**, a ring microstrip conductive layer **1906c** overlays a dielectric layer **1907c** on the dispenser. The ring microstrip conductive layer **1906c** forms microstrip ring antenna cells **1901c**, each having an RFID sensor **1915c**. The conductive layer **1906c** may be

outside the dielectric layer **1907c** as depicted in FIG. **19c** or inside the dielectric layer **1907c** as depicted in FIG. **19d**. Similar to other embodiments discussed herein, a plunger **1944c** may act through a first opening **1938c** to propel items **1902c** through a second opening **1940c**. The traveler **1920c** activated by a spring **1942c**, forces the items **1902c** upwards toward the second opening **1940c**. The position of the traveler **1920c** and the traveler conductive layer **1935c** activates a particular microstrip ring antenna cell **1916c** to send and receive signals to and from an interrogator (not depicted in FIG. **19c**) within a frequency band of operation.

FIG. **19d** depicts yet another embodiment of an RFID-enabled item dispenser **1900d**, otherwise similar to the embodiments of FIGS. **19b** and **19c**, in which a traveler conductive surface **1935d** folded around the traveler dielectric layer **1936d** provides a ground plane with a short on traveler **1920d**. In FIG. **19d**, an insulating layer **1945d** overlays a ring microstrip conductive layer **1906d** on the dispenser. The ring microstrip conductive layer **1906d** forms microstrip ring antenna cells **1901d**, each having an RFID sensor **1915d**. The design with the ring microstrip conductive layer **1906d** on the inside of the insulating layer **1945d** and the traveler design may allow one to make the microstrip ring antenna cells **1901d** and the RFID-enabled item dispenser **1900d** more compact than in other embodiments. Similar to other embodiments discussed herein, a plunger **1944d** may act through a first opening **1938d** to move or propel items **1902d** through a second opening **1940d**. The traveler **1920d** activated by a forcing element such as a spring **1942d**, propels the items **1902d** upwards toward the second opening **1940d**. The position of the traveler **1920d** and the traveler layers **1935d**, **1936d** activates a particular microstrip ring antenna cell **1916d** to send and receive signals to and from an interrogator (not depicted in FIG. **19d**) within a frequency band of operation.

FIG. **19e** depicts another embodiment in accordance with the present disclosure. An RFID-enabled dispenser **1900e** has a cylindrical structure **1909e**, with a circular cross-section **1905e** and a hollow interior region **1903e**. A top layer of ring microstrip antennas **1901e** are wrapped around the circumference of cylindrical structure **1909e**. The ring microstrip antennas **1901e** are each attached to an RFID circuit **1915e**. The cylindrical structure **1909e** optionally has an insulating layer **1908e**. A ground plane typically associated with ring microstrip antennas **1901e** is absent in the embodiment depicted in FIG. **19e**, except as provided by a traveler **1920e**. The traveler **1920e** may have an optional traveler dielectric layer **1937e** that surrounds a traveler conductive layer **1935e**. The traveler **1920e** is displaced due to a forcing element, such as a spring (not depicted in FIG. **19e**) or as described in other embodiments described herein, when items (not depicted in FIG. **19e**) are removed or added. The position of the traveler **1920e** allows the traveler conductive layer **1935e** to provide a ground plane to a particular microstrip antenna **1916e**, to enable the particular microstrip antenna **1916e** and allow the RFID circuit attached to the particular microstrip antenna **1916e** to send and receive signals to and from an interrogator. The interrogator and a processor operate as described herein with respect to other RFID-enabled item dispensers, but are not specifically shown in FIG. **19e**.

FIG. **19f** is an illustration of an RFID-enabled item dispenser **1900f** in accordance with one or more embodiments of the present disclosure in which a top conductive layer **1908f** of one or more microstrip antennas **1901f** is wrapped around a cylinder **1909f** with circular cross-section **1905f**. As in previously described embodiments, a traveler (not depicted in FIG. **19f**) provides the ground plane associated with the top

conductive layer **1908f** to form a completed microstrip antenna conformal to the cylinder **1909f**. A loop **1914f** with an RFID integrated circuit **1915f** is preferably placed in the gap of each antenna **1901f** as depicted in FIG. **19f**. In one embodiment, the microstrip antenna **1901f** is resonant at approximately one-half wavelength. A traveler mechanism, including the traveler, a forcing element, and a dispensing mechanism would operate as described with respect to other embodiments described herein but is not shown in FIG. **19f**.

FIGS. **20**, **21**, **22**, and **23a-c** illustrate one or more embodiments of the present disclosure in the form of a pressure sensor glove **2005**. Referring first to FIG. **20**, the “palm” **2000** side of a pressure sensor glove **2005** comprises ring elements **2010** positioned on foam pads **2015**. The foam pads **2015** are placed at various locations on the palm and digits (i.e., in the areas for the fingers and the thumb), as depicted in FIG. **20**, to yield desired sensitivity such that when a ring element **2010** is depressed, the ring element **2010** couples to a source, such as a first microstrip line **2115** or a second microstrip line **2120** (both depicted in FIG. **21**). The first microstrip line **2115** would be visible in FIG. **20**, but it is hidden under a layer of the glove. On the palm side of the glove, the first microstrip line **2115** may terminate with load elements close to the ring elements situated on the palm. An RFID circuit **2020** is attached to each ring element **2010**. FIG. **21** depicts the other side **2100** of the glove, in other words, the back or top side of the glove **2005**, in accordance with one or more embodiments described herein. A microstrip patch antenna **2110** is connected to the first microstrip line **2115** for coupling to the ring elements **2010** positioned on the palm and to the multiple second microstrip lines **2120** for coupling to the ring elements **2010** positioned on the digits. A load element **2125** is at the end of each second microstrip line **2120**. The load elements **2125** can comprise (for example): (1) a resistive material that absorbs incident electromagnetic (EM) energy to prevent reflections; or (2) an RFID integrated circuit (IC) that reports received power as a status on the health of the system and the amount of power coupled to ring elements **2010**. The load elements **2125** act to prevent unintended impedance mismatch. As depicted in FIG. **22**, an interrogator **2200**, such as a robot-based interrogator, can communicate with the pressure sensor glove **2005** wirelessly, thus eliminating cable runs across joints. A processor (not depicted) may be in communication with the interrogator **2200** to analyze information received by the interrogator **2200**.

The “glove” **2005** could take the form of an artificial hand or other gripping tool, as well as a glove that can be removed from a human or mechanical hand. Similarly, although human hands typically have four fingers and one thumb (designed to be an opposing thumb), the glove **2005** of the present disclosure may be designed with a different number or type of digits, if it would be advantageous for a particular application, for example.

FIGS. **23a-23c** each depict a different detailed embodiment of components on the digits of the glove **2005** of FIGS. **20-22**, with similar arrangements also available for use on the palm (not shown). In FIG. **23a**, a dipole antenna **2305** with direct coupling to depressed rings **2310** is used. The dipole antenna **2305** is partially disposed on the surface of the digit opposite to the positioning of ring elements **2310**. The dipole antenna **2305** may include meandered lines to achieve resonance. In operation, when one or more of the ring elements **2310** are depressed, the depressed ring element **2310** directly couples with the dipole antenna **2305**. The RFID circuit **2020** on the depressed ring element **2310** is correspondingly energized. The RFID circuit **2020** sends information via the

dipole antenna **2305** to the interrogator **2200** and the associated processor for further analysis.

Alternatively, in FIG. **23b**, a top antenna **2320** is placed on top of the digit of the glove **2005**. (Note the position of the top antenna **2320** relative to the load element **2125**.) The top antenna **2320** may, for example, comprise a microstrip patch or a planar inverted “F” antenna. In operation, when one or more of the ring elements **2010** are depressed, the RFID circuit **2020** on the depressed ring element **2010** (or elements) is energized. The energized RFID circuit **2020** sends a response via the top antenna **2320** to the interrogator **2200** and the processor for analysis.

FIG. **23c** depicts another alternate embodiment wherein the antenna is remote from the digit (and thus not depicted in FIG. **23c**). In this embodiment, the second microstrip line **2120** may be connected to the antenna or the interrogator. In operation, when one or more of the ring elements **2010** are depressed, the RFID circuit **2020** on the depressed ring element **2010** (or elements) is energized. The energized RFID circuit **2020** sends a response via the remote antenna to the interrogator **2200** and the processor for analysis.

FIGS. **24-27** depict another group of embodiments of the present disclosure. FIG. **24** is a diagram of a prototype of one embodiment. In the diagram of FIG. **24**, a microstrip transmission line in a loop **2400** creates a circuit with an RFID sensor **2410**. Collectively the transmission line **2400**, circuit and RFID sensor **2410** are called an RFID tag **2420**. The microstrip transmission line loop **2400** of FIG. **24** is printed on a 20 mil thick piece of hydrocarbon ceramic laminate manufactured by the Rogers Corporation and sold commercially as RO 4350. In this prototype, the RFID sensor **2410** comprises an Alien® Higgs-3 SOT sold commercially by Alien Technology of Margan Hill, Calif. While the loop **2400** is shown as being rectangular, other shapes (square or oval for example) could also be used.

FIG. **25** is a diagram of components of a prototype of another embodiment of the present disclosure. In the diagram of FIG. **25**, a 50 ohm load **2510** is connected to a board structure comprising a second microstrip transmission line **2515**, with an RF feed **2520** on the opposing end of the second microstrip transmission line **2515**. The RF feed **2520** is connected to an RFID interrogator (not shown in FIG. **25**) for this prototype, but alternatively, an antenna could be used to receive and transmit signals from and to an RFID interrogator, which may have an internal processor or may be connected to an external processor such as a laptop or desktop computer. The second microstrip transmission line **2515** in FIG. **25** is printed on a second base **2530** of a 175 mil thick, ceramic-filled polytetrafluoroethylene (PTFE) composite material sold by the Rogers Corporation commercially as RO 3003. The 50 ohm load **2510** prevents development of a standing wave pattern. The RFID tags **2420** of FIG. **24** are placed on a substrate **2525**, such as a one half inch thick foam block, face down. The RFID tags **2420** are bonded or otherwise fastened to the substrate **2525** to form this component of the prototype.

FIG. **26** is a diagram of the proper placement of the components shown in FIG. **25**. Specifically, in the diagram of FIG. **26**, proper placement of the substrate **2525** with respect to the second transmission line **2515** is depicted. (The second transmission line **2515** is not visible in FIG. **26** or FIG. **27**, but its position can be determined by the position of the load **2510** and the RF feed **2520**, which can be seen in FIGS. **26** and **27**.) The substrate **2525** bearing the RFID tags **2420** is lined up such that that the top of the RFID tags **2420** line up with the bottom edge of the second microstrip transmission line **2515**, but the RFID tags **2420** do not lay across the top of the second

21

microstrip transmission line **2515** (which, again, is not visible in FIG. **26**, as it is covered by the substrate **2525**).

FIG. **27** contains an illustration of the prototype of FIGS. **24-26** combined with a screen shot of software displaying the results of a test of the prototype. Near the top of FIG. **27**, a schematic diagram depicts that the substrate **2525** is properly positioned over the second transmission line **2515**, leaving part of the second base **2530** exposed. Near the top of FIG. **27**, a schematic diagram of a hand **2700** with two fingers **2705** extended is shown depressing the first and third RFID tags **2710** and **2715**. In general, RFID tags **2420** are only energized and thus are only read when depressed, and multiple RFID tags **2420** may be read at one time, or in succession so quickly that to the user the reading is seemingly occurring at the same time. Software such as the multi-reader software sold as Speedway® Gen2 RFID sold commercially by Impinj, Inc., installed on a processor connected to the RF feed, displays readings from depressed tags. A software display **2720** is depicted in the screenshot of FIG. **27**. The display in the screenshot depicts a line for each of the fifteen RFID tags **2420** shown in FIG. **27**. If an RFID tag **2420** is not being read, the line for that RFID tag **2420** is red in color. Lines representing the RFID tags being read (**2710** and **2715** in this illustration) are displayed in the color white. The first line **2725** and the third line **2730** in the screenshot of FIG. **27** are outlined. On the display, the software provides relevant information from the depressed RFID tags **2420** in a black font with a white background. In this illustrated example, the first and third lines **2725** and **2730**, respectively, are providing relevant information, indicating that depression of the corresponding tags **2710** and **2715** are being read successfully.

FIG. **28** depicts a diagram of a ring sensor **2800** which may be used in various embodiments described herein. The ring sensor **2800** may comprise a source element **2802** such as a microstrip waveguide or a type of antenna and a conductive ring **2804** connected to an RFID integrated circuit **2806**. While the conductive ring **2804** of FIG. **28** is represented as having a predominantly rectangular shape, the loop of conductive ring **2804** may comprise a variety of other shapes, such as circular, elliptical, triangular, square, trapezoidal, polygonal, or any other shape suitable for performing the function of indicating a position in relation to the source element **2802**.

FIG. **29a** depicts a diagram of a ring sensor **2900a**, which may be used in various embodiments described herein. The ring sensor **2900a** comprises a source element **2902**, which might be a microstrip waveguide or a type of antenna, and a conductive ring **2904a** connected to an RFID integrated circuit **2906a**. An RFID interrogator (shown generally in FIG. **1** as interrogator **145** although not shown in FIG. **29a**) communicates with the RFID integrated circuit **2906a** when the position and rotation of the ring **2904a** is suitable for coupling to the source element **2902**. In this general sense, the source element **2902** and ring **2904a** can be used as a sensor to detect when the ring **2904a** has been moved laterally into the enabling position (as shown), vertically, or in general a combination of lateral and vertical positioning (both not shown). In addition, the ring **2904a** will not generally couple well when the orientation of the ring edges are not predominantly aligned with the source element **2902**. For example in FIG. **29a**, the ring **2904a** will couple to the source element **2902**, whereas in FIG. **29b**, the ring **2904b** has been rotated about an x-axis such that it no longer couples with the source element **2902**. While the conductive ring **2904a** of FIG. **29a** and the conductive ring **2904b** of FIG. **29b** are each represented as having a predominantly rectangular shape, the conductive rings **2904a** and **2904b** of FIGS. **29a-29b** may have a variety

22

of other shapes, such as circular, elliptical, triangular, square, trapezoidal, polygonal, or any other shape suitable for performing the function of indicating a position in relation to the source element **2902**.

FIGS. **30a** and **30b** are diagrams of a two-part RFID ring tag **3000** used as a sensor to detect whether a hinged door is in an open or closed position, with FIG. **30b** comprising a diagram of the two-part RFID ring tag **3000** installed on a door hinge. The two-part RFID ring tag **3000** comprises a ring circuit **3005** and an antenna **3010**. When the two-part RFID ring tag **3000** door is installed on the door hinge as depicted in FIG. **30b** and the door is closed, the ring circuit **3005** is suitably close to the antenna **3010** such that the antenna **3010** couples energy to the ring circuit **3005**. An interrogator (shown generally as interrogator **145** of FIG. **1** although not depicted in FIG. **30a** or **30b**) is able to send information to, and receive information from, the energized ring circuit **3005** of the two-part RFID ring tag **3000**, signaling that the door is closed.

FIGS. **31a** and **31b** depict another embodiment described herein. In this embodiment, a ring sensor **3100** is used as a switch. The ring sensor or switch **3100** comprises a ring tag **3104** with an RFID integrated circuit **3106** operatively connected thereto. The ring tag **3104** is attached to a membrane **3103** that pivots about a rotational axis **3110**. In FIG. **31a**, the membrane **3103** is in the “off” state such that the ring tag **3104** is not enabled to couple energy to and from a source element **3102**, which might be, for example, a meandered dipole or a microstrip patch antenna. When the membrane **3103** is rotated about the rotational axis **3110**, as shown in FIG. **31b**, however, the ring tag **3104** is enabled and can receive energy from, or transmit energy to, an interrogator (shown generally as interrogator **145** of FIG. **1** although not shown in FIG. **31a** or **31b**). The membrane **3103** may be fastened at one or both ends by a latch, a hook-and-loop fastener (commonly referred to as “Velcro”, a magnet, or any of a number of other fastening elements, including an adhesive (although not depicted in FIG. **31a** or **31b**)). The membrane **3103** might be an insulating fabric or rigid insulating element. In one embodiment, the membrane **3103** comprises a strip of insulating fabric, the source element **3102** comprises a fabric antenna, and a section of a hook-and-loop fastener is used to fasten the end of the membrane **3103** in either the “off” or “on” position. An array of similar switches may be worn on a shirt and used to communicate commands or other information to a processor through an RFID interrogator.

Any of a number of other switch mechanisms is possible with a variety of options to captivate the ring sensor in both “off” positions, which disable communications to the tag, and “on” positions, which enable communications to a tag.

In light of the principles and exemplary embodiments described and illustrated herein, it will be recognized that the exemplary embodiments can be modified in arrangement and detail without departing from such principles. Also, the foregoing discussion has focused on particular embodiments, but other configurations are contemplated. In particular, even though expressions such as “in one embodiment,” “in another embodiment,” “in a version of the embodiment” or the like are used herein, these phrases are meant to generally reference the range of possibilities of embodiments, and are not intended to limit the disclosure to the particular embodiments and configurations described herein. As used herein, these terms may reference the same or different embodiments that are combinable into other embodiments.

Similarly, although exemplary processes have been described with regard to particular operations performed in a particular sequence, numerous modifications could be

applied to those processes to derive numerous alternative embodiments of the present disclosure. For example, alternative embodiments may include processes that use fewer than all of the disclosed operations, processes that use additional operations, and processes in which the individual operations disclosed herein are combined, subdivided, rearranged, or otherwise altered.

In view of the wide variety of useful permutations that may be readily derived from the exemplary embodiments described herein, this detailed description is intended to be illustrative only, and should not be taken as limiting the scope of the disclosure. What is claimed as the disclosure, therefore, are all implementations that come within the scope of the following claims, and all equivalents to such implementations. In the claims, means-plus-function and step-plus-function clauses are intended to cover the structures or acts described herein as performing the recited function and not only structural equivalents, but also equivalent structures. Thus, while a nail and a screw may not be structural equivalents in that a nail employs a cylindrical surface to secure wooden parts together, whereas a screw employs a helical surface, in the environment of fastening wooden parts, a nail and a screw may be equivalent structures.

What is claimed is:

1. A system for a radio frequency identification (RFID)-enabled dispenser comprising:

a plurality of conductive layers forming a waveguide;

a dispensing container placed within the waveguide, the dispensing container having a first opening for dispensing items located therein;

a plunger capable of acting through a second opening in the dispensing container for moving the items to be dispensed through the first opening;

a traveler for moving items within the dispensing container towards the first opening, the traveler movable in response to force exerted by a forcing element;

a collector coupled to the waveguide;

an interrogator configured to transmit an incident signal to the collector, creating an electromagnetic field within the waveguide, the electromagnetic field being affected by one or more influences;

a processor configured to receive information from the interrogator; and

one or more RFID field sensors placed inside the waveguide at intervals along the axial direction of the waveguide, each RFID field sensor having an identification and capable of responding to the electromagnetic field by transmitting, via the collector, reflected signals to the interrogator, the reflected signals containing information that identifies the responding RFID field sensors, wherein the interrogator is configured to receive the reflected signals, measure one or more returned signal strength indications ("RSSI") of the reflected signals and send the RSSI measurements and the corresponding identification of the responding RFID field sensors as inputs to the processor and the processor is configured to use the inputs to make at least one determination about the one or more influences.

2. The system of claim 1, wherein the collector comprises an antenna.

3. The system of claim 1, wherein the waveguide comprises a parallel plate waveguide.

4. The system of claim 1, wherein the one or more influences includes the number of items located in the dispenser.

5. The system of claim 1, wherein the one or more RFID field sensors comprise an array of RFID integrated circuits attached to a transmission strip.

6. The system of claim 1, wherein the traveler is predominately conductive and the one or more influences includes the position of the traveler.

7. The system of claim 1, further comprising an RFID sensor embedded into the traveler, wherein the one or more influences includes the position of the traveler.

8. The system of claim 1, wherein the traveler is designed to present a predetermined, but arbitrary, electromagnetic load and the one or more influences includes the position of the traveler.

9. The system of claim 1, wherein the forcing element comprises a spring connected to a side of the traveler opposite to the location of items to be contained in the dispensing container, and wherein the collector provides an input signal to a spring end of the waveguide, the waveguide comprising a coaxial waveguide having an inner conductor, the inner conductor comprising the spring.

10. The system of claim 9, wherein the waveguide comprises a parallel plate waveguide, wherein the RFID field sensors are positioned along one gaps between the parallel plates.

11. The system of claim 9, wherein the waveguide comprises a fully enclosed conductive cylinder and wherein the RFID field sensors are positioned in an internal volume of the conductive cylinder.

12. A radio frequency identification (RFID)-enabled dispenser comprising:

multiple antenna cells, comprising two sets of a plurality of antenna patterns, each antenna pattern containing an RFID field sensor having a unique identification encoded therein; and

a dispenser unit having a dispensing mechanism configured to dispense items from the dispenser unit, and a traveler for moving items located within the dispenser unit towards the dispensing mechanism, the traveler configured to move in accordance to force exerted by a forcing element,

wherein the traveler comprises a dielectric body and the position of the traveler and its dielectric body being configured to enable at least one of the RFID field sensors to send a response to an incident signal from an interrogator, said response being configured so as to enable the interrogator to receive the response, to measure one or more returned signal strength indications ("RSSI") of the response and to send the RSSI measurements and the corresponding identification of the responding RFID field sensors as information to a processor, wherein such information once processed enables the interrogator to determine the position of the traveler.

13. The dispenser of claim 12, further comprising a holder having an elongated structure upon which the multiple antenna patterns are positioned, the holder configured to allow the dispenser unit to be positioned therein.

14. The dispenser of claim 12, wherein the first set of antenna patterns comprises a set of first conductive cell patterns on a first printed circuit board and the second set of antenna patterns comprises a set of second conductive cell patterns on a second printed circuit board, and wherein the dispenser unit is positioned between the first printed circuit board and the second printed circuit board, the first and second printed circuit boards comprising a holder for the dispenser unit to be positioned therein.

15. The dispenser of claim 13, wherein the response to be received by the interrogator from the RFID field sensors includes a frequency response.

25

16. The dispenser of claim 15, wherein the frequency response includes a multitude of channels corresponding to EPCglobal RFID protocols.

17. The dispenser of claim 14, wherein the RFID field sensors comprise surface acoustic wave (SAW) devices.

18. The dispenser of claim 14, wherein the set of first conductive cell patterns comprises an RFID inlay circuit, the first printed circuit board being formed by attaching the RFID inlay circuit to a dielectric layer, the RFID inlay circuit comprising a plurality of conductive patterns, each conductive pattern containing an RFID integrated circuit.

19. The dispenser of claim 14, wherein the set of first conductive cell patterns is electrically connected to a region of the set of second conductive cell patterns, the first conductive cell patterns and the second conductive cell patterns being positioned outside of an interior volume of the dispenser unit through which the traveler passes, the set of second conductive cell patterns configured to create a quarter-wave antenna in the antenna cell.

20. The dispenser of claim 14, wherein the set of first conductive cell patterns is electrically connected to a region of the set of second conductive cell patterns, the first conductive cell patterns and the second conductive cell patterns being positioned outside of an interior volume of the dispenser unit through which the traveler passes, the set of second conductive cell patterns configured to create a planar inverted-F (PIFA) antenna in the antenna cell.

21. The dispenser of claim 14, wherein the set of first conductive cell patterns are characterized with at least one empty region and an RFID integrated circuit, and the set of second conductive cell patterns comprise a single filled conductive region.

22. The dispenser of claim 14, wherein the set of first conductive cell patterns are positioned on the inside of the dispenser unit and supported by an insulating outer body, the traveler further comprising a conductive surface so as to provide a folded ground plane with a short.

23. A method of measuring an amount of items located within a dispenser, comprising:

providing a holder having an elongated structure and multiple antenna cells, each antenna cell containing a radio frequency identification (RFID) field sensor, the dispenser having an opening for dispensing the items and a traveler for moving the items within the dispenser towards the opening, the traveler moving in response to force exerted by a forcing element, the traveler having a dielectric body;

placing the dispenser with the holder;

transmitting an incident signal from an interrogator to an antenna indirectly coupled to the holder causing the antenna to generate an electromagnetic field along the holder, the electromagnetic field being affected by the amount of items located within the dispenser, each RFID field sensor having an individual identification;

enabling a single one of the RFID field sensors to receive and respond to the incident signal from the interrogator based on the position of the traveler and the dielectric body of the traveler within one of the multiple antenna cells containing the single one of the RFID field sensors;

transmitting a reflected signal from the single one of the RFID field sensor to the interrogator in response to the electromagnetic field, the reflected signal including the individual identification from the responding RFID field sensor;

measuring one or more returned signal strength indications ("RSSI") of the reflected signal by the interrogator;

26

sending the RSSI measurements and the corresponding individual identification of the responding RFID field sensor from the interrogator to a processor; and analyzing the RSSI measurements and identifications by the processor to make determinations about the one or more influences.

24. The method of claim 23, wherein the identification of the single one of the RFID circuits responding to the incident signal is used by the processor to determine the position of the traveler and the number of the items within the dispensing container.

25. A radio frequency identification (RFID)-enabled dispenser comprising:

a holder comprising an elongated structure with multiple antenna cells, each antenna cell containing an RFID circuit having a unique identification, each antenna cell being of sufficient size for resonance so as to enable the antenna cell to tune to an operating frequency of its respective RFID circuit; and

a dispensing container placed within the holder, the dispensing container having an opening for dispensing items from the dispensing container, a traveler for moving items within the dispersing container towards the opening, the traveler moving in response to force exerted by a forcing element, wherein the traveler includes a dielectric body, the position of the traveler and its dielectric body being configured for activating a proximate antenna cell in which the traveler is positioned nearby and enabling the RFID circuit within the proximate antenna cell to receive an incident signal from an interrogator and to send a response to the interrogator such that the response is capable of being received by the interrogator, the response further comprising one or more returned signal strength indications ("RSSI") capable of being measured and received along with a corresponding identification of the responding RFID circuits as information by a processor configured to use the information received to determine the position of the traveler.

26. The apparatus of claim 25, wherein each antenna cell comprises a top floor and bottom floor, both the top floor and the bottom floor being both operably flat and operably perpendicular to the direction of movement of the traveler, the top floor having a first conductive pattern and the bottom floor having a second conductive pattern, with interior sections of the top floor and the bottom floor being hollow to support the dispensing container.

27. The apparatus of claim 26, wherein the first and second conductive patterns comprise identical patterns.

28. The apparatus of claim 25, further comprising an electromagnetic short on one end of the antenna cells.

29. The apparatus of claim 25, wherein the traveler comprises an enhanced coupler.

30. The apparatus of claim 29, wherein the enhanced coupler comprises a dielectric body that tunes antenna performance of the proximate antenna cell, the enhanced coupler further comprising a top conductive pattern and a bottom conductive pattern that align respectively with a first conductive pattern and a second conductive pattern of the proximate antenna cell when the traveler is positioned in the proximate antenna cell.

31. The apparatus of claim 29, wherein the enhanced coupler is configured to improve an impedance match between an antenna located within the proximate antenna cell within which the traveler is positioned and the RFID circuit to which the proximate antenna is tuned.

27

32. The apparatus of claim 29, wherein the enhanced coupler alters resonance of an antenna located within the proximate antenna cell within which the traveler is positioned and wherein the processor is configured to determine the position of the traveler according to the frequency response of the activated proximate antenna cell.

33. The apparatus of claim 32, in which the frequency response comprises at least one channel corresponding to the EPCglobal Class 1 Generation 2 protocol.

34. The apparatus of claim 29, wherein the enhanced coupler includes at least one conductive pattern and further comprises a top conductive pattern and a bottom conductive pattern with an insulator in the middle.

35. The apparatus of claim 34, wherein the traveler comprises a short between the top conductive pattern and the bottom conductive patterns of the enhanced coupler, the short being configured to tune the proximate antenna cell as the traveler is positioned thereby.

36. The apparatus of claim 34, wherein the forcing element comprises one of a spring, gravity, a lever system, and a system of gears.

28

37. The apparatus of claim 25, wherein each antenna cell comprises a microstrip ring antenna cell formed by a conductive layer on the dispensing container, the dispensing container coated with a dielectric layer beneath the conductive layer, the traveler further comprising a traveler conductive layer beneath a traveler dielectric layer such that the traveler conductive layer forms a ground with a proximate microstrip ring antenna cell near which the traveler is positioned, thereby enabling a RFID field sensor operatively coupled with the proximate microstrip ring antenna cell to exchange signals with the interrogator.

38. The apparatus of claim 25, wherein the RFID circuits are disposed on an insulating layer of the dispensing container, the dispensing container having a hollow interior region with a top conductive layer, and wherein the antenna cells are microstrip antennas wrapped around an outside surface of the dispensing container, the traveler further comprising a traveler dielectric layer and a traveler conductive layer.

* * * * *