

Lessons Learned From Developing Advanced Space Power Systems Applied to the Implementation of DC Terrestrial Micro-Grids

**IEEE EnergyTech 2012
Case Western Reserve University**

**Cleveland, Ohio
May 29-30, 2012**

**James F. Soeder
Raymond Beach
Larry Trase
NASA Glenn Research Center
Cleveland, Ohio**



Discussion Topics

- **Why is NASA interested in Smart Grid?**
- **Advanced Terrestrial Smart Grids**
- **ISS Description**
- **DC Power Challenges**
 - **Fault Control**
 - **Stability**
- **Wrap-up**

Why Intelligent Power / Smart Grid?

- **NASA**
 - Provide a utility-like power generation and distribution capability with automated operation to enable deep space exploration and settlement
- **Terrestrial**
 - Increase the power delivery capability and reliability of the grid by integrating renewables and energy storage without major increases to the transmission and generation infrastructure

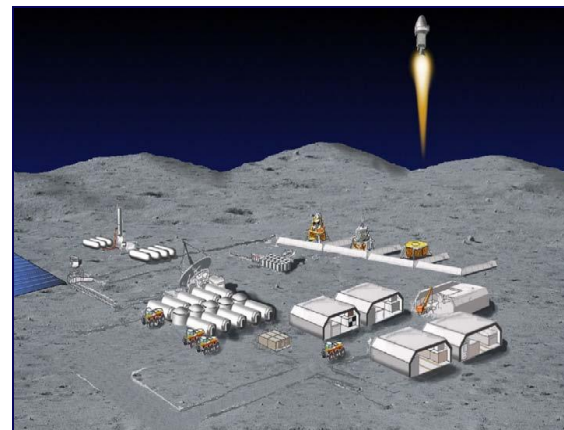



Power Grid Challenges

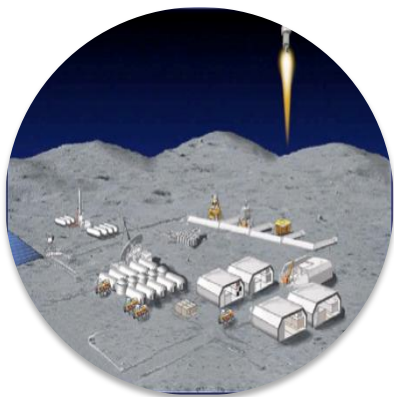

Exploration Power

Terrestrial Power

X	Increased power demands	X
X	Utilization of diverse power sources (renewables)	X
X	Incorporation of large amounts of distributed energy storage	X
X	Seamless accommodation of Variable / Peak load demand	X
X	Failure diagnostics and prognostics for power components	X
X	Automated control for operations management, fault detection and system reconfiguration	X
X	Long term reliability / availability for exploration survivability and terrestrial users	X

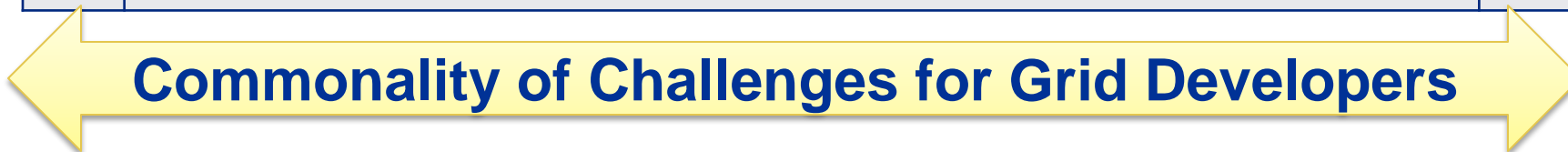



Advanced Terrestrial Smart Grids



...the Grid of the Future?*

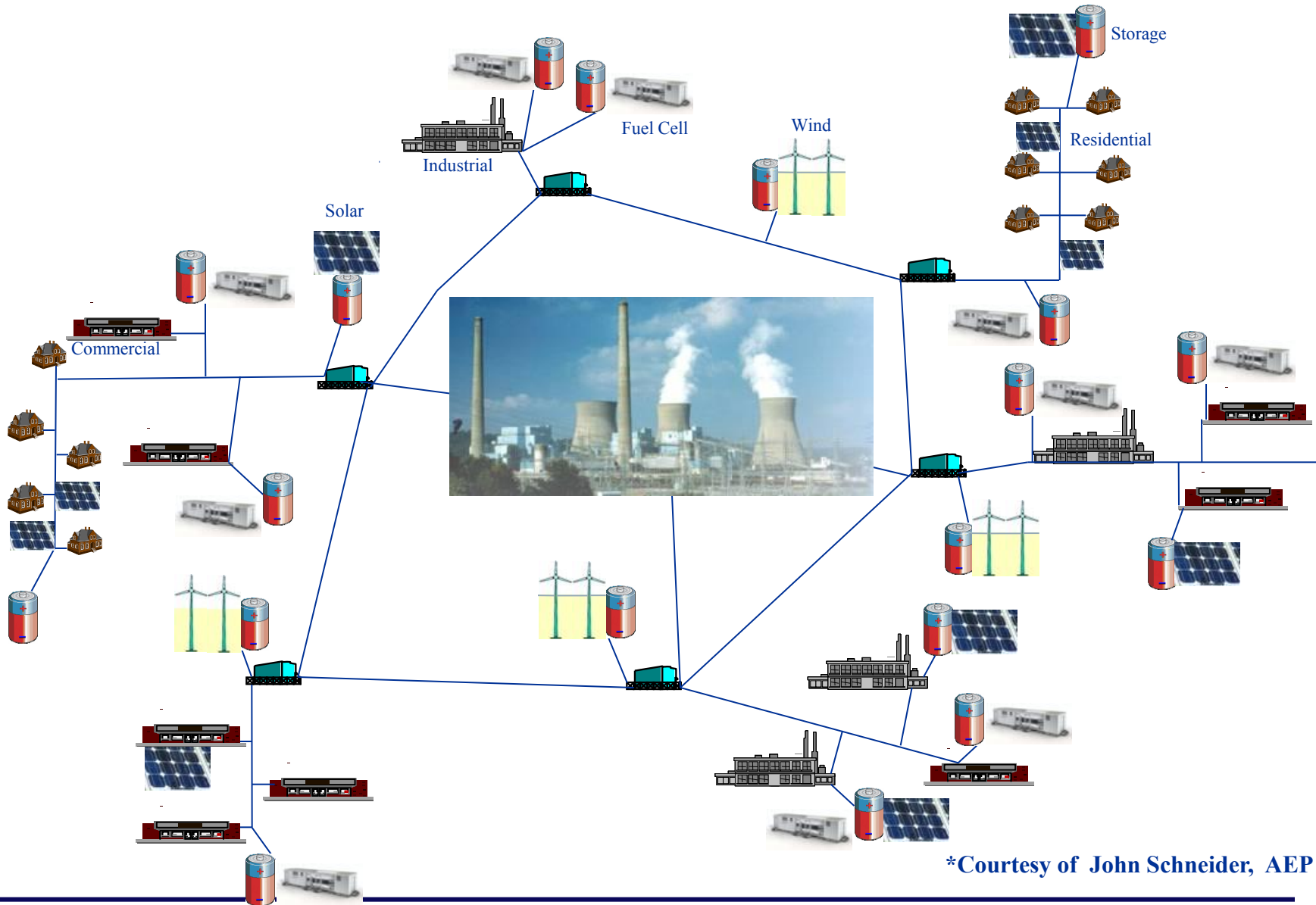

*Courtesy of John Schneider, AEP



Advanced Power Grid Hierarchy

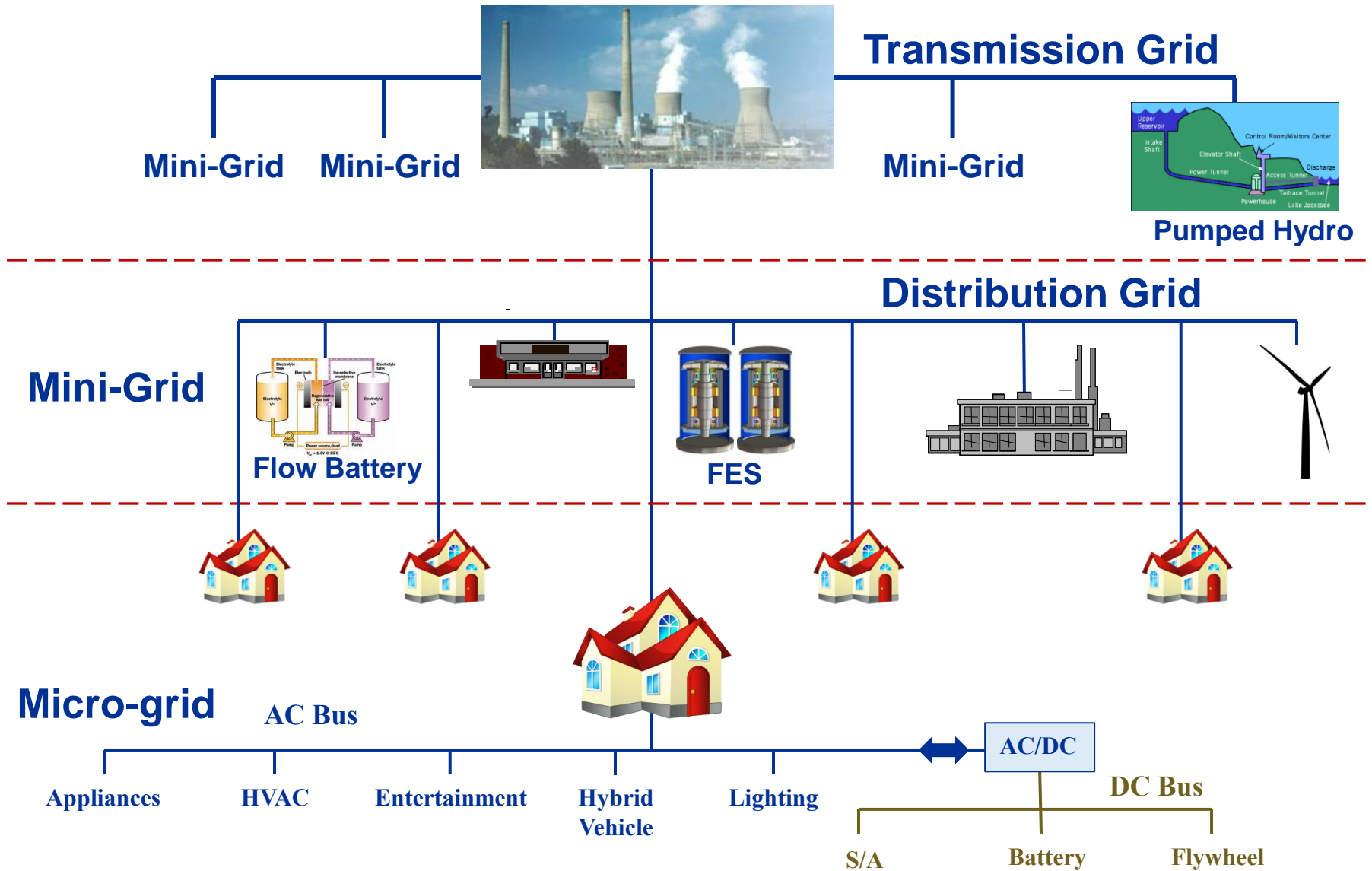



More Advanced Power Grid Hierarchy

Transmission Grid

Mini-Grid

Mini-Grid



Mini-Grid

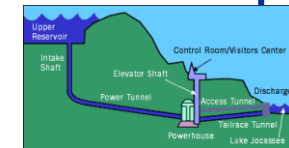

Pumped Hydro

AC/DC

AC Bus

DC Bus

Mini-Grid

Flow Battery

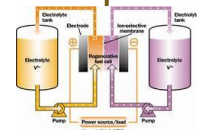

FES

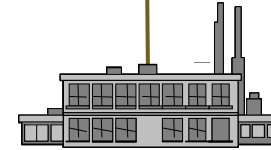
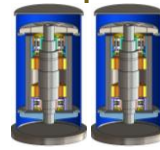

Micro-grid

DC Bus

Appliances

HVAC

Entertainment

Hybrid Vehicle

Lighting

S/A

Battery

Flywheel



Why DC Micro grids?

- **DC powered electrical devices make up 50 to 80%* of the load in many buildings**
 - **Computing equipment**
 - **LED lighting will become more common**
- **Variable speed drives are penetrating into the appliance market.**
- **Many renewables such as solar / wind / batteries (flow and non-flow) fuel cells flywheels etc. are already compatible with DC systems (Have DC outputs)**

*** Nextek Power Systems**



DC Distribution and the International Space Station

Size

Width: 108 meters
Length: 80 meters

Weight:
456,279 kilograms

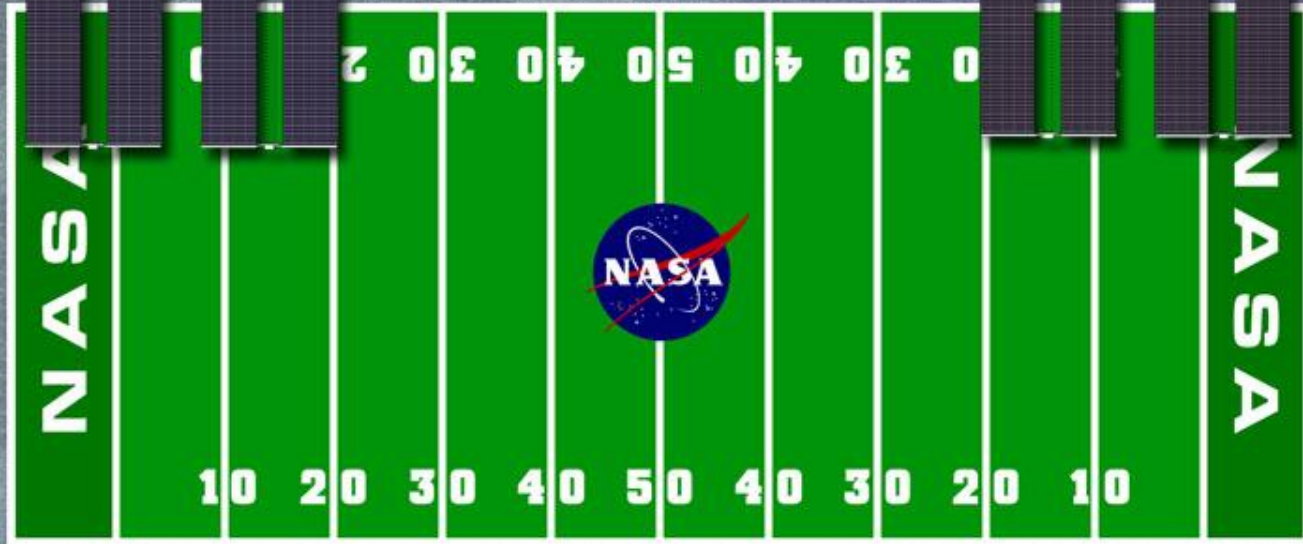



International Space Station

Power System Characteristics

- **Power 75 kW average**
- **Eight independent power channels -- 9.75 kW**
- **Solar array power 200+ kW**
 - **Planar silicon arrays**
 - **18% Efficient**
- **NiH battery storage – 3 per channel (2 ORUs)**
 - **76 cells @ 81 amp*hrs / battery**
- **Distribution**
 - **116 - 170 V primary**
 - **120 V secondary**
- **Contingency power > 1 orbit**
- **System lifetime of 15+ years**





ISS Primary Grid

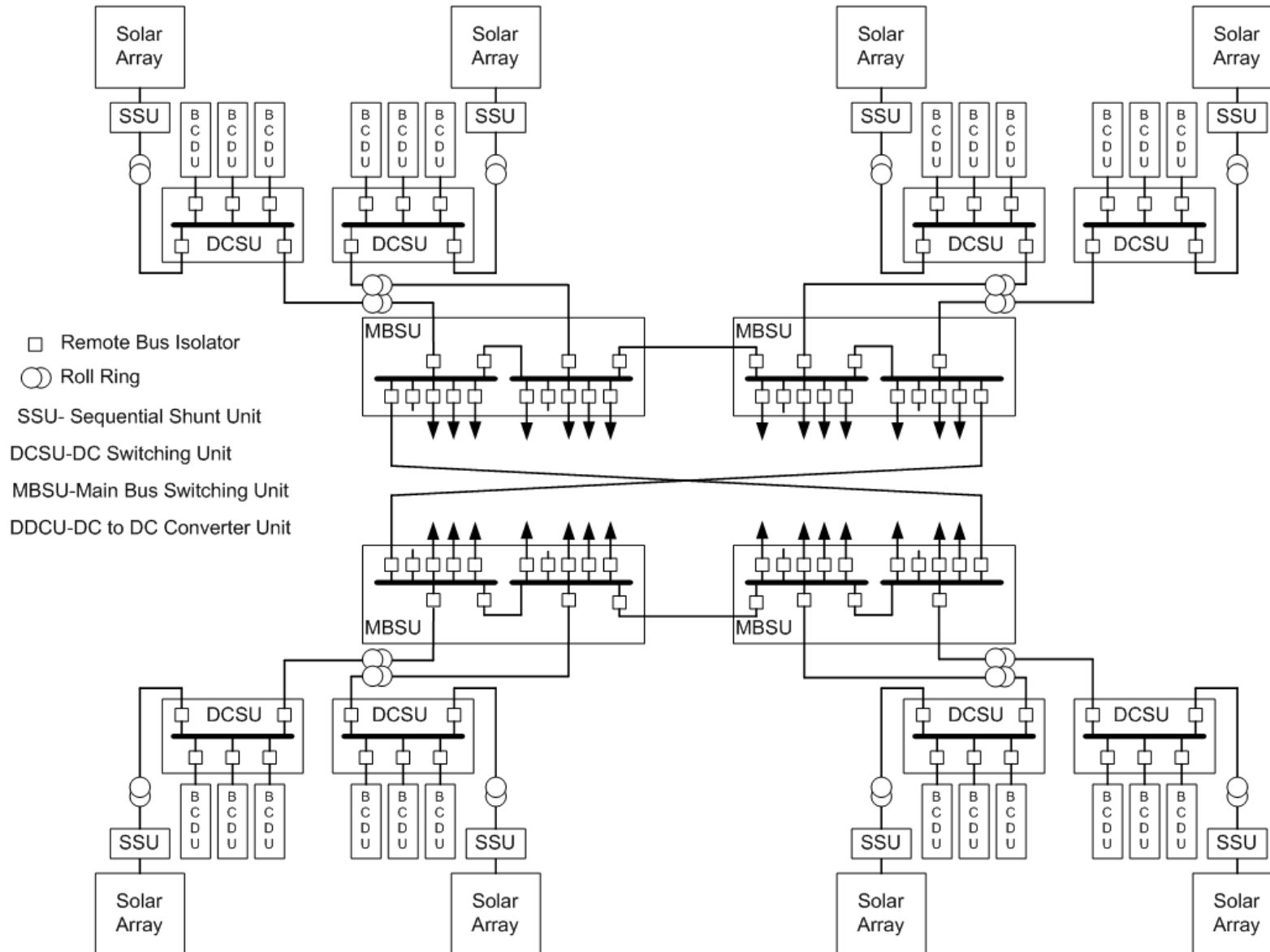



Considerations in DC Distribution Systems

- **Stability with multiple power converters**
- **Coordinated DC fault control @ high voltage**

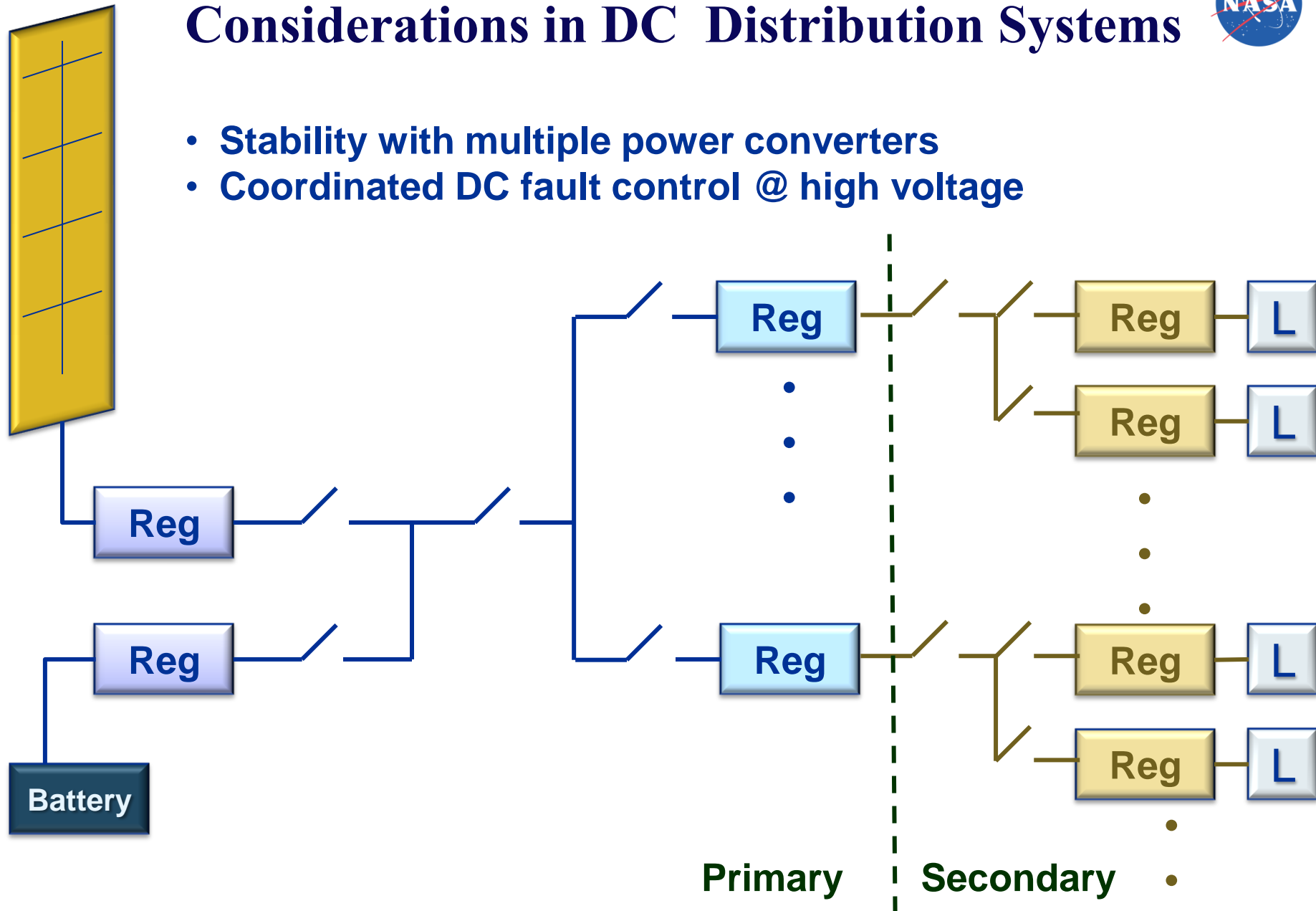



Stability

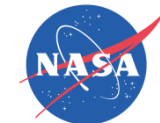

Power System Stability

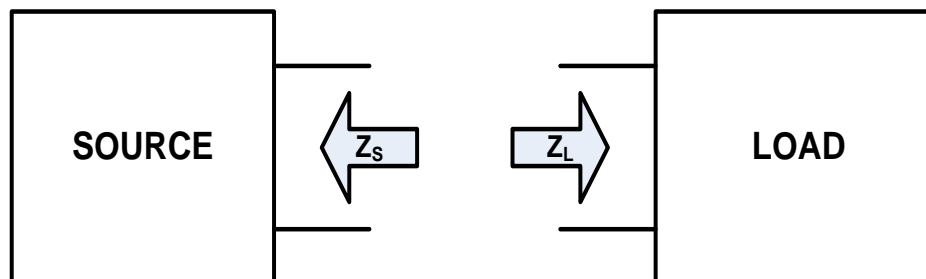

- If $|Z_S| < |Z_L|$ for all frequencies, then the system is stable
- When $|Z_S| > |Z_L|$, further analysis is needed to determine system stability.

$$Z = \frac{Z_S \cdot Z_L}{Z_S + Z_L} = \frac{Z_S}{\frac{Z_S}{Z_L} + 1}$$

From SAE Spec AS5698

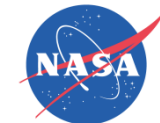

Power System Stability

- If $|Z_S| < |Z_L|$ for all frequencies, then the system is stable

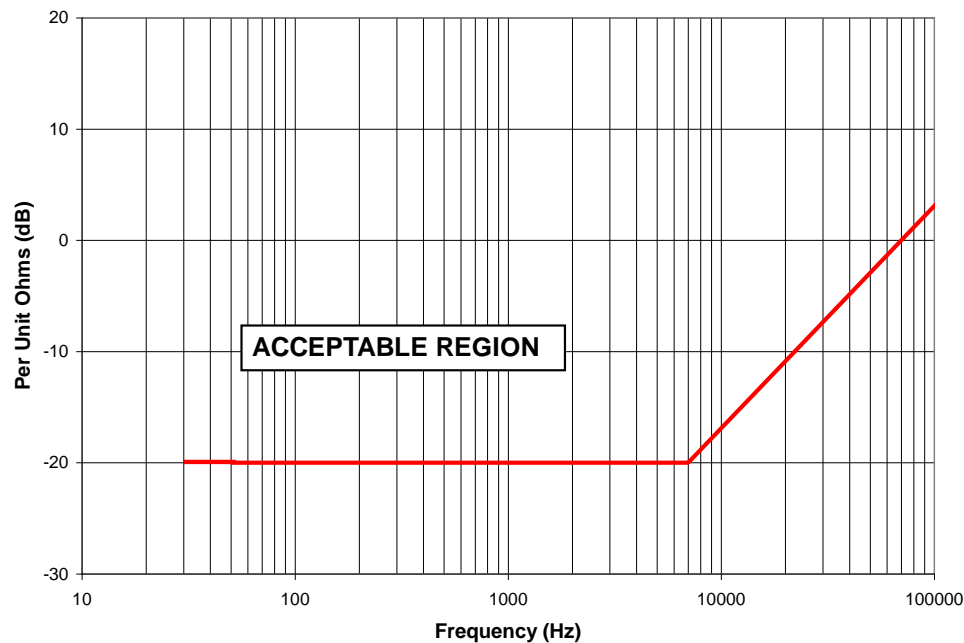

Normalized load Input Impedance Limit



Power System Stability

- When $|Z_S| > |Z_L|$, further analysis is needed to determine system stability

- Using the Nyquist criterion, small-signal system stability can be determined by whether the curve of Z_S/Z_L circles the $(-1, 0)$ in the S-plane

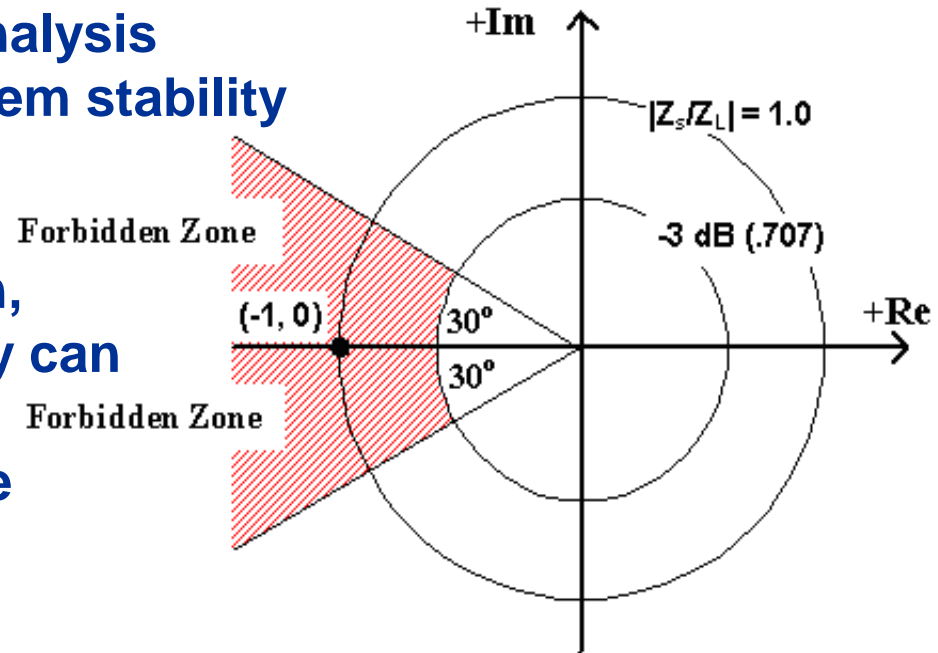

- The forbidden region on this diagram establishes a system stability margin.

From SAE Spec AS5698

Power System Stability Examples

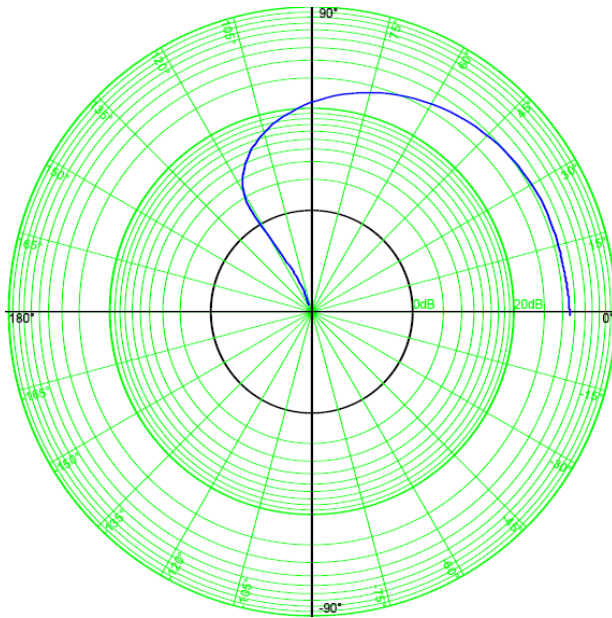

Stable System

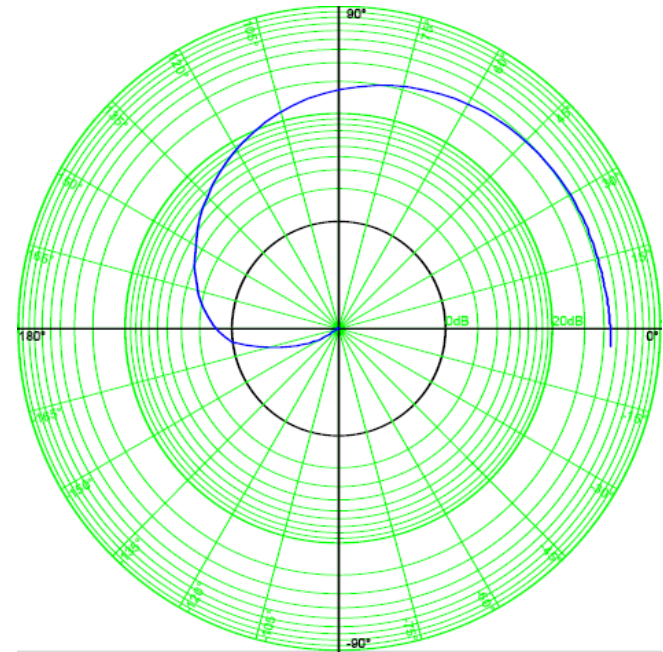

Under damped but stable system



Stability

- **With soft sources it is generally impractical to avoid crossover of source and load impedances**
 - **Stability is generally determined by phase margin**
- **Loads should have 3 db Ohms of gain margin, or 30 degrees of phase Margin with respect to source impedance**
- **Limit cycles must be avoided when applying loads to current limited sources and resettable protective devices**
- **Phase Margin is 180 degrees minus phase**



DC Fault Control

















DC Fault Control

- **Fault Clearing for DC systems is inherently difficult because the current never passes through zero.**
- **Challenges**
 - **Clear the fault quickly with minimum stress on the system**
 - **Minimize the effect on other branches of the system**
- **Coordinated fault response**
 - **Switch closest to the fault needs to trip first**
- **Form factor should be compact and lightweight**



DC Switchgear

	Fuse	Mech Relay	Hybrid	CL Solid State
Resettable	N	Y	Y	Y
Mass	B			
Losses	B			
Coordination	B			
System Impacts	B			
Complexity	B			

	Best		Worse	B – Baseline Y – Yes
	Better		Worst	



Mechanical Switch: Kilovac Vacuum Relay



**Kilovac 500 A Vacuum Switch
“Bubba”**

Description

- AP350X “Bubba” -- Largest space-rated switch
- Voltages:
 - 270 Vdc continuous
 - 350 Vdc 10 μ sec
- Currents:
 - 500 A continuous
 - <5000 A surge
- Switching time: 10 msec
- Magnetic arc blow-out
- Low loss
- No current limiting
- System transients tend to be high

Hybrid Switch

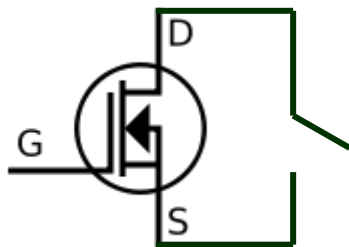

Schematic of hybrid switch

Description

- Contains both mechanical and Solid state components
- Solid state switch permits “soft” turn-on and turn-off
- Mechanical switch provides low loss in on-state
- Mechanical switch does not need to be sized for interrupt
- Trip coordination can be tricky

Current Limited RPC

Description

- Remote Power Controllers control and protect electrical system
- Current limited RPCs provide absolute protection for system wiring
- Can be reset
- Can be paralleled to increase current handling capability
 - Unlike fuses or circuit breakers
- Utilizes an innovative v^2t trip curve.
- Can distinguish between sever and slight overload
- Multi-level trip coordination is easily implemented
 - Avoids ambiguity of using i^2t trip curves

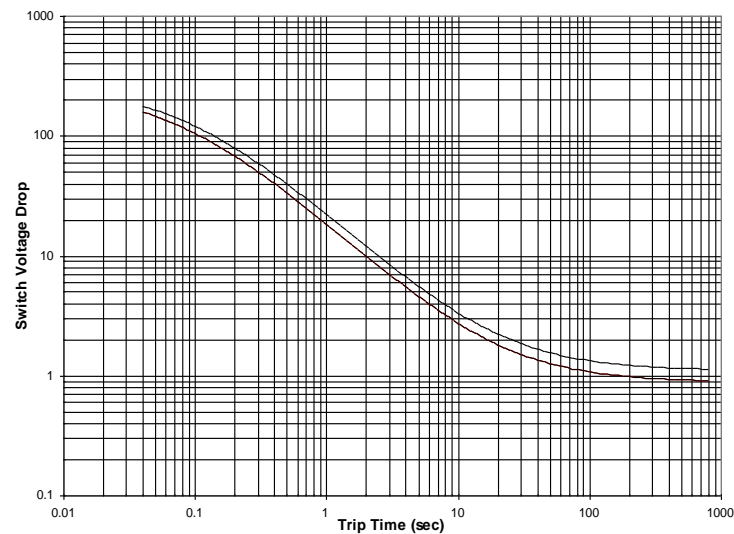
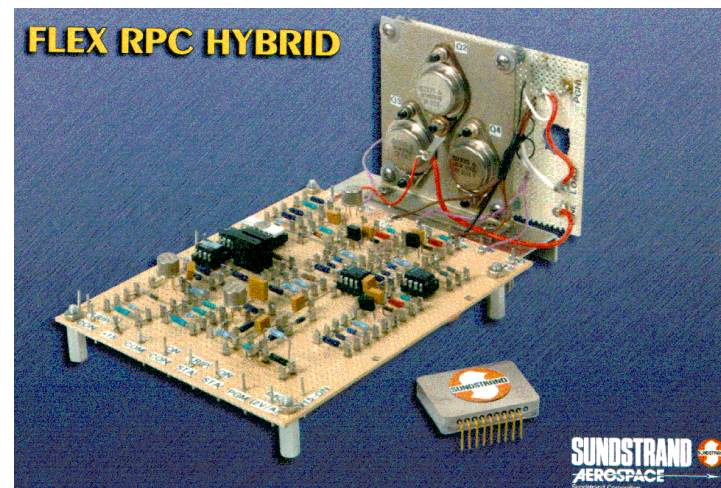



Switch Voltage Drop

Description

- Utilizes switch voltage drop to determine trip time
- Can distinguish between sever and slight overload
- Trip curve utilizes semiconductor 's safe operating area

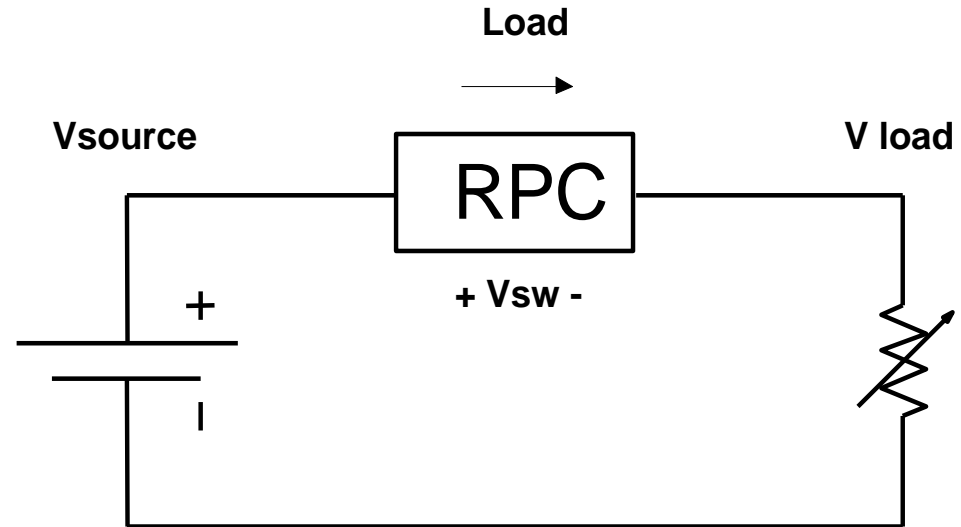
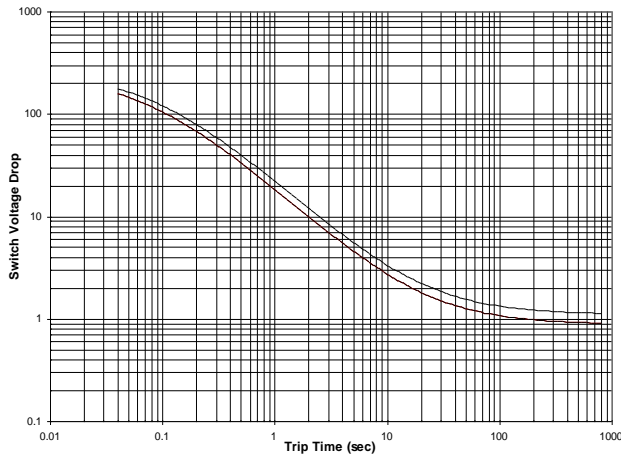

$$P_{sw} = Load * V_{sw}$$

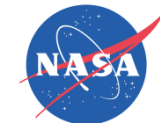

Coordination Example

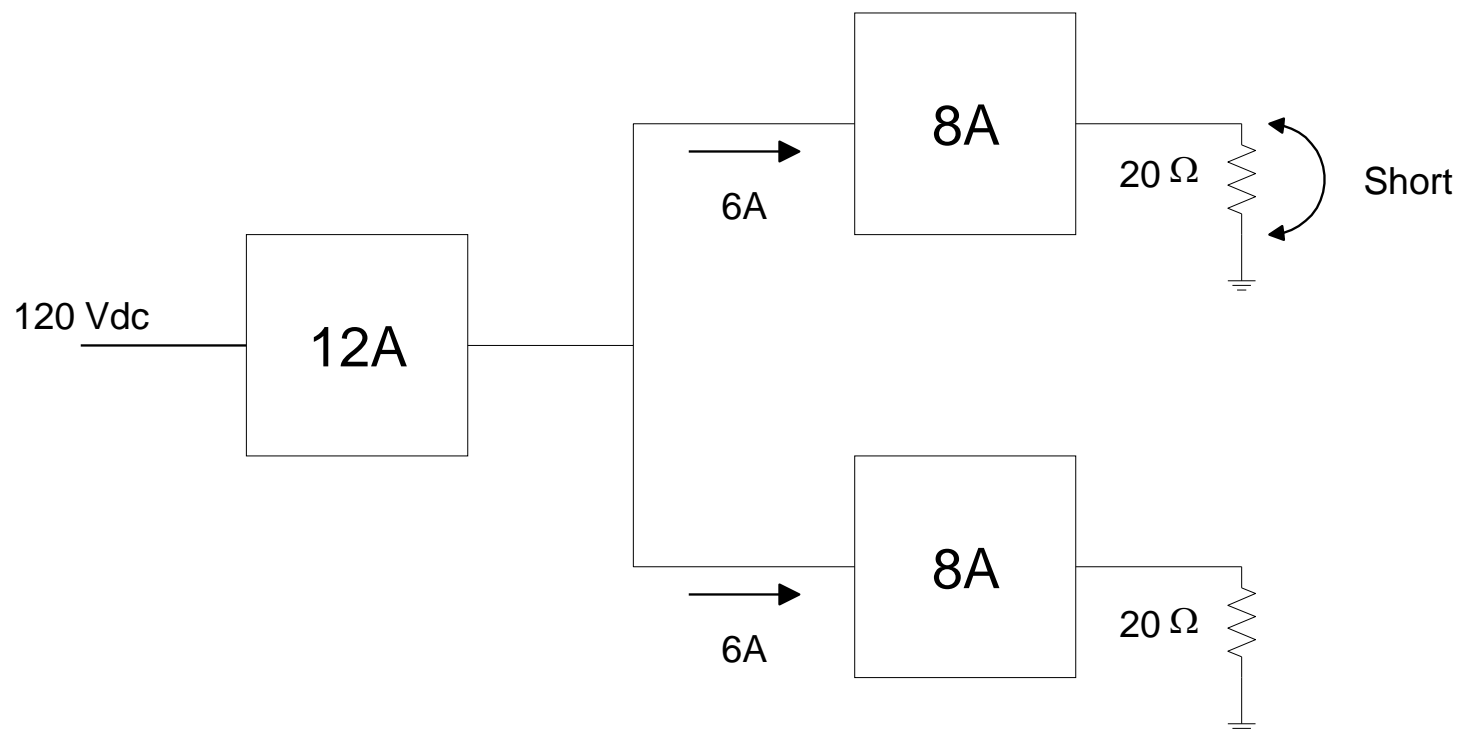



Coordination Example

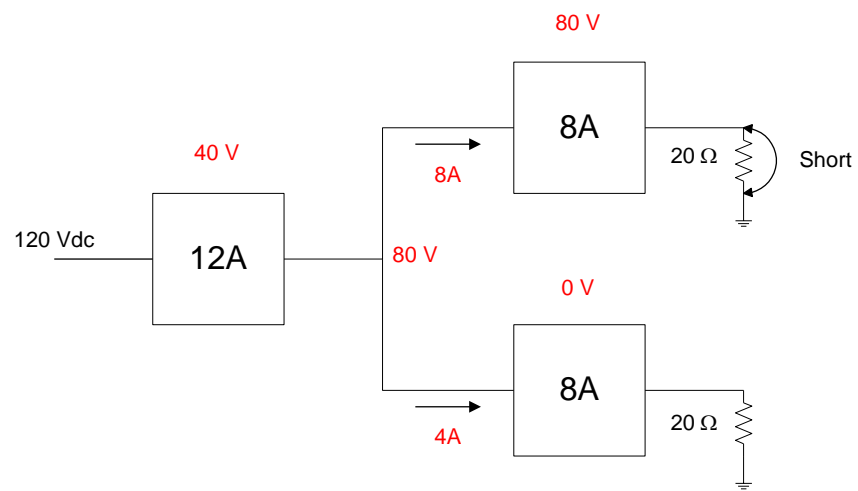
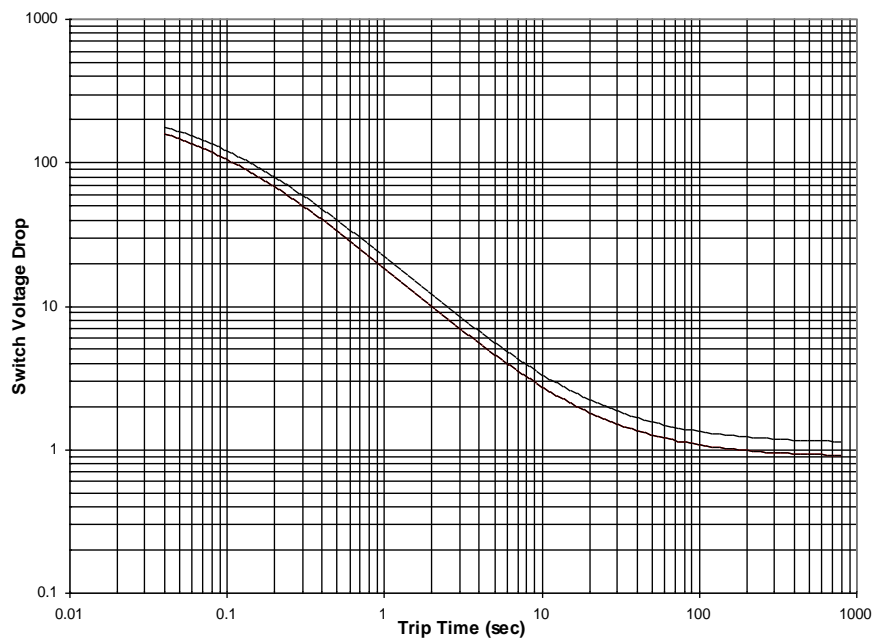



Wrap-Up

- **Advanced DC terrestrial micro-grids can learn a great deal from experience developing the International Space Station Power System**
- **The negative impedance of multiple power converters in series can pose stability challenges**
- **Fault control with soft sources such as power converters and solar arrays needs to be accommodated**



References

- **David Fox -- Hamilton Sundstrand Corp.**
- **James Soltis – NASA Glenn Research Center**
- **Nextek Corporation**



Back-up

ISS Power Architecture

Challenges

- Evolution to accommodate peak power
- Variable Loads with constrained sources
- Automated operation

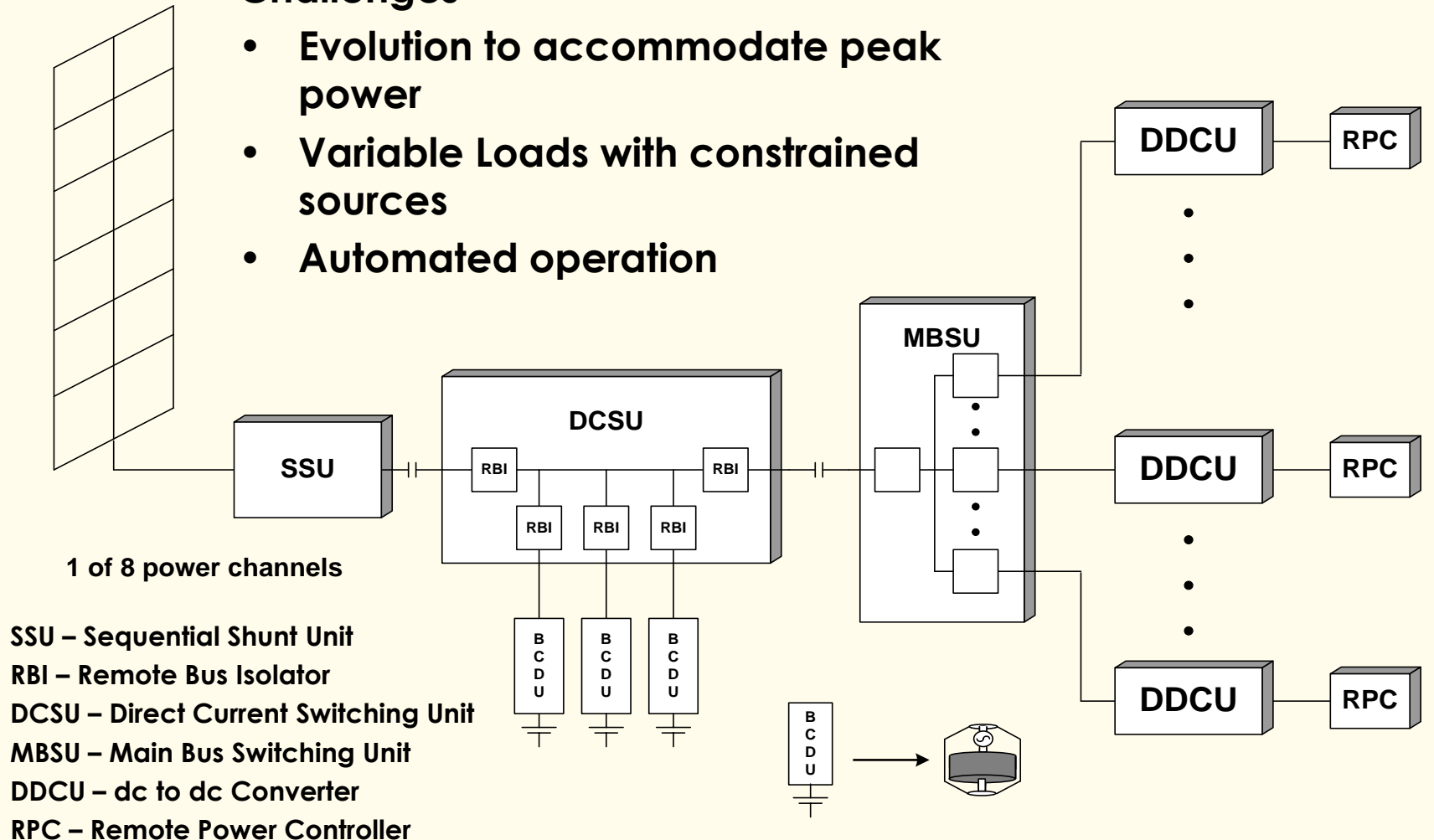



Coordination Example

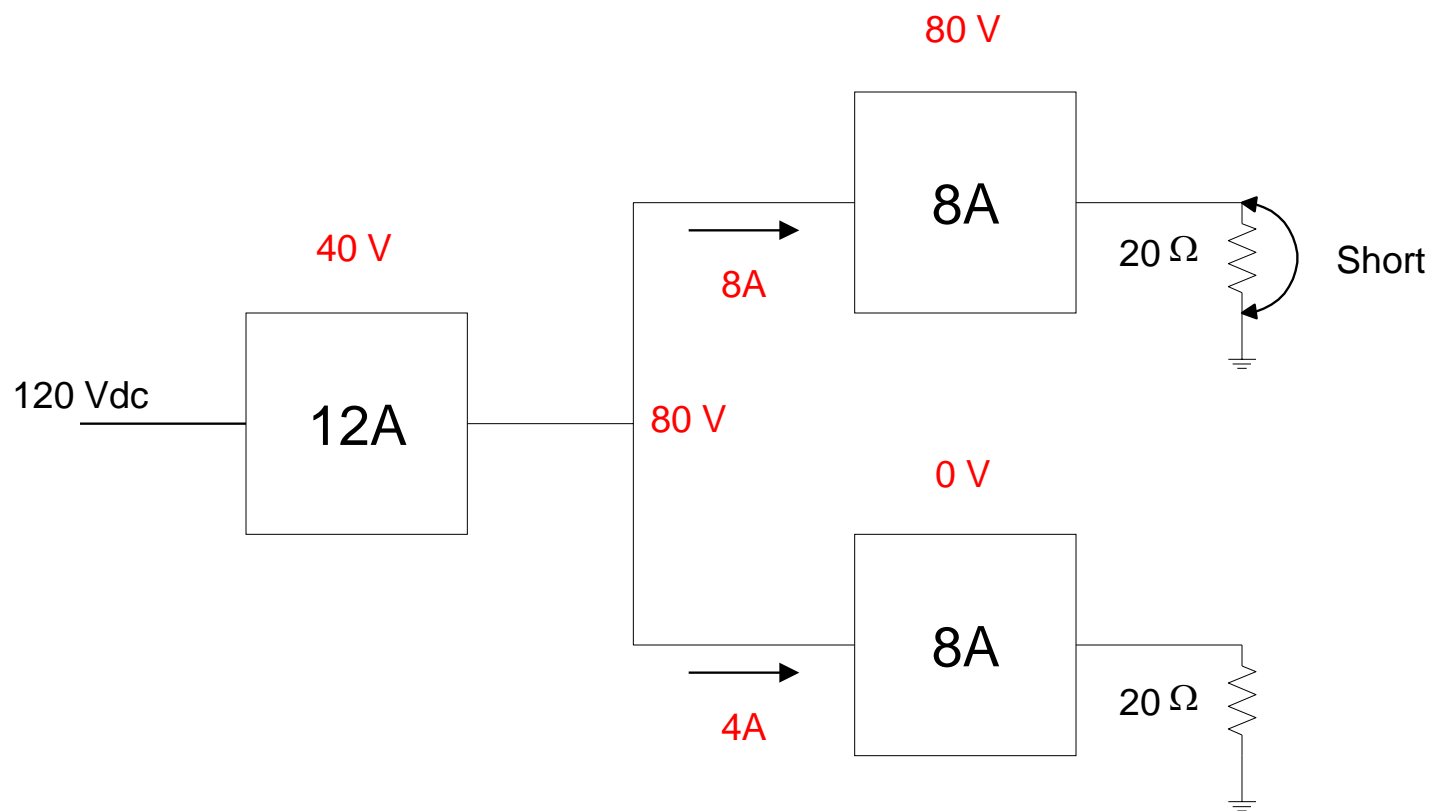



What is NASA's Interest In Smart Grid?



ISS Automation

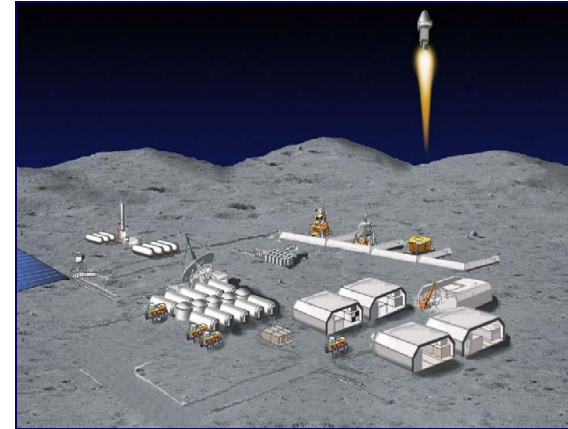

Planetary Surface Power Systems



Facility Sustainability



Deep Space Habitat

NASA's interest is in the development of technologies that benefit space exploration and enable the Terrestrial Smart Grid