

Adapting the SpaceCube v2.0 Data Processing System for Mission-Unique Application Requirements

David Petrick, Nat Gill, Munther Hassouneh, Robert Stone, Luke Winternitz, Luke Thomas, Milton Davis, Pietro Sparacino, and Thomas Flatley

NASA Goddard Space Flight
Greenbelt, MD 20771
david.j.petrick@nasa.gov

Abstract—The SpaceCube™ v2.0 system is a superior high performance, reconfigurable, hybrid data processing system that can be used in a multitude of applications including those that require a radiation hardened and reliable solution. This paper provides an overview of the design architecture, flexibility, and the advantages of the modular SpaceCube v2.0 high performance data processing system for space applications.

The current state of the proven SpaceCube technology is based on nine years of engineering and operations. Five systems have been successfully operated in space starting in 2008 with four more to be delivered for launch vehicle integration in 2015. The SpaceCube v2.0 system is also baselined as the avionics solution for five additional flight projects and is always a top consideration as the core avionics for new instruments or spacecraft control.

This paper will highlight how this multipurpose system is currently being used to solve design challenges of three independent applications. The SpaceCube hardware adapts to new system requirements by allowing for application-unique interface cards that are utilized by reconfiguring the underlying programmable elements on the core processor card. We will show how this system is being used to improve on a heritage NASA GPS technology, enable a cutting-edge LiDAR instrument, and serve as a typical command and data handling (C&DH) computer for a space robotics technology demonstration.

TABLE OF CONTENTS

1. INTRODUCTION	1
2. SPACECUBE v2.0 OVERVIEW	2
3. LIDAR INSTRUMENT.....	2
4. GPS APPLICATION	4
5. ROBOTICS APPLICATION	5
6. CONCLUSIONS.....	7
7. FUTURE WORK	7
REFERENCES.....	7
BIOGRAPHY	8

1. INTRODUCTION

SpaceCube is a family of Field Programmable Gate Array (FPGA) based on-board science data processing systems developed at NASA Goddard Space Flight Center (GSFC) [2]. The goal of the SpaceCube program is to provide 10x to 100x improvements in on-board computing power while

lowering relative power consumption and cost. SpaceCube is based on the Xilinx Virtex family of FPGAs, which include processor, FPGA and digital signal processing (DSP) resources. These processing elements are leveraged to produce a hybrid science data processing platform that accelerates the execution of algorithms by distributing computational functions to the most suitable elements. This approach enables the implementation of complex on-board functions that were previously limited to ground based systems, such as on-board product generation, data reduction, calibration, classification, event/feature detection, data mining and real-time autonomous operations.

The system is fully reconfigurable in flight, including data parameters, software and FPGA logic, through either ground commanding or autonomously in response to detected events/features in the instrument data stream.

A. Background

The SpaceCube processing system at GSFC was started in 2006 funded by the Internal Research and Development (IRAD) program [4]. NASA recognized the potential of the technology and provided the funding needed to increase the Technology Readiness Level (TRL) for space flight applications. Specifically, the Hubble Space Telescope Servicing Mission 4 management team selected the SpaceCube as the main avionics for a space shuttle payload called Relative Navigation Sensors (RNS) [2, 3, 5, 8, 9].

The version of the SpaceCube that was initially developed in the 2006-2009 timeframe is known as SpaceCube v1.0. Following the success of the RNS mission, a v1.0 system was added to an International Space Station experimental payload to study long term effects of radiation [2, 3, 7, 10, 15]. SpaceCube v1.0 is also the main avionics system controlling two follow-on International Space Station (ISS) experiments for the Department of Defense (DoD) [11]. SpaceCube v1.5 was the bridge from v1.0 to v2.0 technology improvement [12, 15]. SpaceCube Mini is based on the v2.0 architecture and fits within a 1U CubeSat form factor, but will not be discussed in this paper.

B. Hybrid Data Processing

There is a growing need for higher performance processing systems for space as instruments/spacecrafts levy tougher electrical interfacing and data bandwidth requirements on the computing node of the system. In addition, on-board

processing of the data products, in some cases in real-time, is now a common requirement [1].

Typical space processing systems generally consist of a single radiation hardened processor which deliver less than 300 DMIPS along with an anti-fuse FPGA element [1]. These processors are not good candidates for applications that require fast computations of complex algorithms on a high bandwidth or large volume data source. Furthermore, this type of FPGA supports fixed functionality and cannot adapt to changing application requirements. These architectures are very hard to design and intrinsically expensive to change such that they are portable to multiple missions, dynamic functional requirements, or new post launch mission objectives or corrections.

A hybrid computing system that combines multiple processors, reconfigurable FPGAs, flexible interface options, with a modular architecture is the solution that will bridge the gap between today's avionics requirements and yesterday's typical stand-alone, sequential processing architecture.

2. SPACECUBE v2.0 OVERVIEW

The SpaceCube v2.0 processing system is based on an extended version of the 3U cPCI standard form factor where each card is 190mm x 100mm in size. Unlike SpaceCube v1.0 which was a stacking architecture, cards can be easily swapped in and out of the system. The base system consists of a power card, processor card, backplane, and mechanical chassis to accommodate two additional cards. The size of the four slot chassis is 13x23x27cm³ and weighs approximately 5kg with four cards installed. Typical power draw heavily depends on the number of cards and complexity and speed of the FPGA designs. The base system will draw 15-20W for a moderate application. A full system running an advanced application can draw 40W+. This system will be qualified for an operating temperature range of -25C to +50C and a total ionizing dose of 100Krad.

The SpaceCube v2.0 data processing card features two back-to-back Xilinx Virtex-5 FPGAs [6], eight memory modules (2GB DDR, 8GB NAND Flash, 16MB SRAM, 128Mb PROM), a monitor FPGA with analog monitoring, 10/100 Ethernet, configurable interconnect including gigabit transceivers. The backplane is designed as point-to-point so each I/O card does not require a PCI controller. The entire system including details on design methodology, architecture, card descriptions, mechanical packaging, and analyses is fully described in [1].

The v2.0 processor card infrastructure supports on-orbit reconfiguration that was proven on the v1.0 system on the ISS [2, 10]. Referencing Figure 6 in [1], the Aeroflex FPGA configures the Xilinx FPGAs with initial configuration files that are stored in PROM. Reconfiguration is achieved by allowing the Xilinx FPGAs to reconfigure each other with design files that are stored in Flash. All files are stored in a redundant fashion (e.g. TMR,

QMR, etc) and the file structure is mirrored in both Flash devices. Additional design files can be written to Flash while the system is on-orbit. The Aeroflex serves as the health monitor of the Xilinx configuration and can trigger a rollback to PROM. To mitigate configuration SEUs, the Aeroflex or the Xilinx can perform configuration monitoring and scrubbing. The scrubbing occurs at a programmable rate or when an error has been detected. The architecture allows for a reliable means of controlling the Xilinx configuration data.

The modularity of the SpaceCube v2.0 system allows for quick adaptation to changing avionics requirements. A modular and reconfigurable system increases the likelihood of reuse for different mission applications, or follow-on missions, even if interface and computing requirements are drastically different. As shown in [3], cost and schedule can be reduced by reusing the same basic system for new missions. Reuse of hardware architecture greatly reduces the amount of up front Non Recurring Engineering (NRE) costs and time associated with building a new system with new requirements from scratch.

Sections 3-5 will highlight how this system is being used to improve on a heritage NASA GPS technology, enable a cutting-edge LiDAR instrument, and serve as a typical C&DH computer for a space robotics technology demonstration on a relatively accelerated schedule.

3. LIDAR INSTRUMENT

Goddard's Reconfigurable Solid-state Scanning LiDAR (GRSSLi) is an in-house GSFC technology development project pursuing a space flight imaging proximity LiDAR with unique capabilities to generate 3 dimensional imagery (see Figure 1) at high frame rates for on-orbit autonomous rendezvous and docking (AR&D) and extreme measurement accuracy for planetary scientific investigation. Utilizing advanced high TRL technologies such as microelectromechanical systems (MEMS) laser beam steering and high performance reconfigurable computing of the SpaceCube v2.0, as well as GSFC's deep understanding of laser based sensing systems, GRSSLi is pushing the boundaries of terrestrial and space flight LiDAR technology.

The GRSSLi system offers two operational modes: high speed imaging, and precision measurement. In high speed imaging mode, the laser is rastered over the scene firing at a 200 KHz rep rate. FPGA logic processes reflected laser pulses in real time every 5 microseconds producing a measurement with 6mm range resolution and down to 5.6mm noise 1 σ . With a 128 x 128 raster scan over GRSSLi's 40° field of view, this equates to 12 Hz images. Thus, GRSSLi furnishes comparable frame rates and spatial resolutions to flash lidars with measurement quality that is 10 to 50 times better. In the 40° degree FOV configuration our system is sensitive from 1- 50 meters. We intend to advance our current detector and laser technologies to

extend our range up to at least 100 meters without sacrificing the wide FOV.

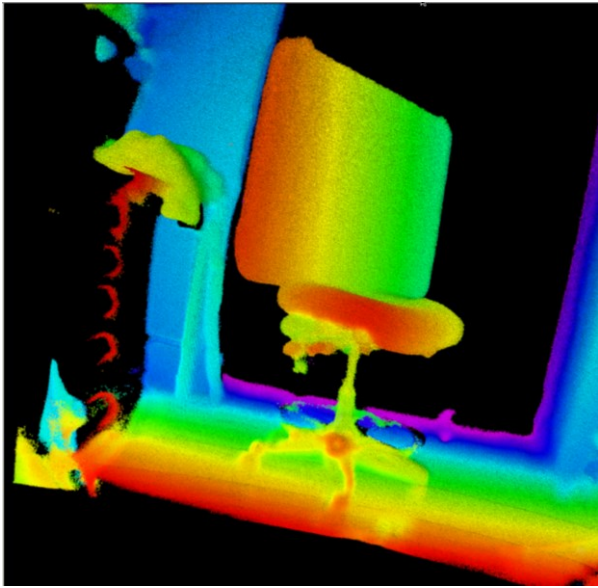

Figure 1 – 4 megapixel point cloud of a whiteboard on a lab chair acquired by GRSSLi

In precision measurement mode, GRSSLi averages reflected laser pulses within a SpaceCube FPGA at a 3 MHz rate to produce high quality range measurements with 0.5mm range resolution and 1.3mm noise 1σ every 87 milliseconds. This is useful for producing high quality scans of rocks and other planetary features during rover based or asteroid exploration missions. Additionally, programmable MEMS laser beam steering allows the system to track the location of a retro reflector with unprecedented accuracy, thus enabling precise closed loop positioning of robotic arms improving mission efficiency and scientific yield.

A. Digitizer Card

The GRSSLi system design necessitates a high speed analog to digital converter (ADC) to sample receiver wave forms. The chosen converter utilizes 4 x 12 bit low-voltage differential signaling (LVDS) buses operating at 400 MHz each in addition to various control signals. It was therefore determined that the backplane could not support this number of IO, and the SpaceCube v2.0 processor card had to be modified to include the high speed ADC on the card itself. Also to generate the ADC RF clock a mezzanine card was added to the digitizer card.

To accommodate ADC circuitry, 2 DDR chips originally connected to the bottom V5 FPGA as well as Ethernet circuitry were removed from the original SpaceCube v2.0 processor card design. The end result is an extremely capable 2 Virtex-5 processor board (see Figure 2) that can sample 2 differential RF channels at 1.54 GSPS with 12 bit resolution and process/interpret the signals in real time.



Figure 2 - LIDAR High-Speed Digitizer Card

B. Laser Card

The GRSSLi system design also requires a high reliability 3uJ 1550nm 200 KHz rep rate fiber laser. A custom rad-hard circuit card was designed and integrated with space flight qualified electro-optic components to produce the SpaceCube v2.0 compatible laser card pictured in Figure 3. It receives a digital pulse from the digitizer card that triggers a seed laser which is amplified by an integrated Erbium Doped Fiber Amplifier (EDFA). The output of the EDFA is sent to the collimator lens pointed at the MEMS mirror, which directs the laser out of the optical system and into the world.

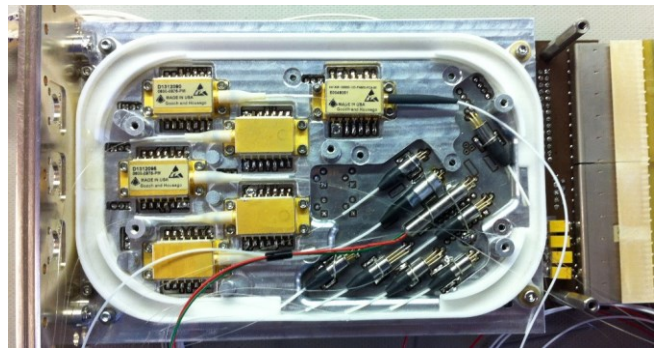

Figure 3 – LIDAR Laser Card

C. Front-End Interface Card

The Front End Interface Card (FEIC) shown in Figure 4 is a custom SpaceCube v2.0 compatible cPCI card for interfacing the main GRSSLi SpaceCube box to the Front End box as described in the next section.



Figure 4 – LIDAR Front-End Interface Card

D. GRSSLi Front End Box

The GRSSLi system is separated into two boxes as shown in the Figure 5 system diagram. The Main Electronics Box (MEB) and the Front End Box (FEB). The MEB contains all the SpaceCube v2.0 compatible 3U cards described above, whereas the FEB contains a custom rad hard MEMS driver card, a Short-Wave Infrared receiver card delivered by the Army Research Lab [13], the MEMS mirror, and all the necessary optics.

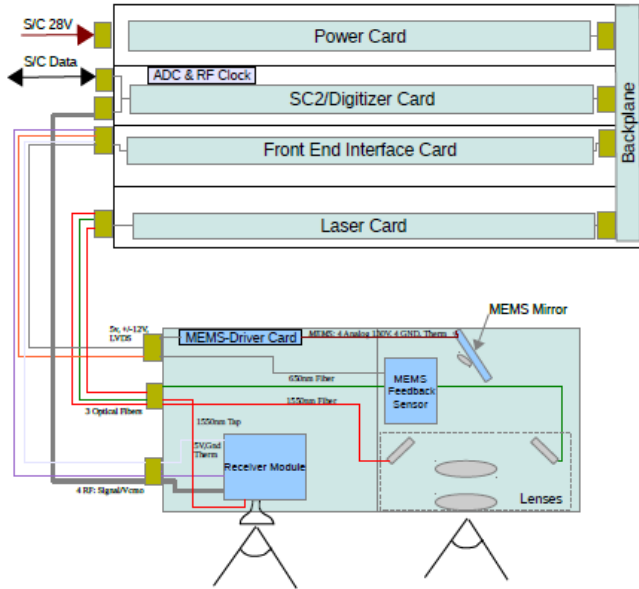

Figure 5 - GRSSLi System Block Diagram

F. GRSSLi System

All of the previously described components have been integrated, as shown in Figure 6, and are currently undergoing system level functional testing. Linux is running on a MicroBlaze processor within the top Virtex-5 on the Digitizer, and driver code has been developed to interface the GRSSLi specific FPGA IP to the software system.

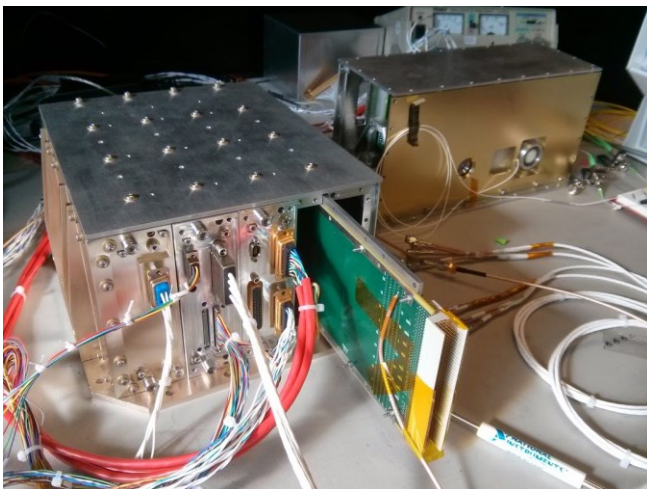

Figure 6 – GRSSLi SpaceCube and Front End Box

Since the DDR on the bottom FPGA was removed to make room for the ADC, we developed a custom PLB bridge that facilitates MicroBlaze local bus transactions and DMA's between FPGAs. This effectively extends the system on a chip paradigm to system on multiple chips, allowing the processor easy access to any number of Xilinx FPGAs and facilitating great flexibility when crafting the embedded system.

The end result is a very capable and adaptable space flight LiDAR for use in many potential robotic and scientific applications. In the future we plan to miniaturize the design and combine the two boxes into a single small size, weight, and power (SWaP) instrument as well as increase capability by enhancing range.

4. GPS APPLICATION

Goddard's Navigator is a standalone, high-sensitivity, fast acquisition, space-qualified GPS receiver originally designed to enable high altitude GPS navigation [14]. Navigator is a mission enabling technology for the extremely challenging Magnetospheric Multi-Scale Mission (MMS) that was launched in March 2015 where it is exceeding its required performance, tracking more GPS vehicles at greater distances than the baseline mission required [17]. It also serves as a critical navigation sensor for the Global Precipitation Measurement Mission (GPM) that launched in February 2014 and has supported several other recent missions (Hubble Space Telescope Service Mission 4 [5], Orion MPCV). The Navigator design was licensed to Moog Broad Reach Engineering in 2010, and they now build a commercial version of it. Recently, the Navigator design has been licensed to another company.

Table 1 – Comparison of FPGA Utilization on Original Navigator and Next Generation SpaceCube Navigator

Legacy GPS Signal Processing Hardware (L1 C/A Receiver)	Track FPGA (RTAX2000)	97% Register Cells 95% Comb. Cells 85% RAMs
	Acquisition FPGA (RTAX2000)	80% Register Cells 90% Comb. Cells 61% RAMs
	Communications FPGA (RTAX2000)	78% Register Cells 55% Comb. Cells 35% RAMs
	FFT FPGA (RTAX2000)	61% Register Cells 88% Comb. Cells 78% RAMs
SpaceCube 2.0 Processor Card (L1 C/A and L2C Receiver)	Receiver FPGA (one Virtex 5 FX130)	76% Slice Registers 52% DSP Elements 31% Block RAMs

The original Navigator tracks GPS L1 C/A signals, and its design uses four Actel RTAX2000 FPGAs and a ColdFire microprocessor to implement its signal processing. The ColdFire processor and the four Actel FPGAs are fully utilized with no room for expansion or modernization (see Table 1). The next generation Navigator uses the SpaceCube v2.0 as a flight platform. Under GSFC IRAD funding, the FPGA logic from the four Actel FPGAs on the original Navigator has been retargeted to a single reprogrammable Xilinx Virtex 5 FX130T FPGA on the SpaceCube and the ColdFire has been replaced by a MicroBlaze soft-core processor instantiated in the same FPGA. Modernized GPS L2C signal tracking capability has been also implemented on the same FPGA. GPS signals are provided to the processor by a new RF card, compatible with the SpaceCube v2.0 chassis, and described further in the next subsection.

In addition to advancing the capabilities of the original Navigator, the SpaceCube platform provides ample resources (GPS L1 C/A, GPS L2C and the MicroBlaze processor require less than one FPGA on the SpaceCube, see Table 1) and improvements in SWaP as well as cost. The SpaceCube provides a flight-ready platform with room for expansion for future applications including processing of the other modernized GPS signals (GPS L5 and modernized L1C) and signals from other GNSS constellations (Galileo, GLONASS, and COMPASS).

A. Dual Frequency GPS L1/L2 RF Card

To provide GPS signals to the digital processor, a two-chain, dual-frequency, discrete component RF front-end card, with 3U (extended) cPCI form-factor, has been designed, built, tested and integrated on the SpaceCube v2.0 platform (see Figure 7). The RF card takes GPS L1 and L2 signals from the GPS antenna and low noise amplifier (LNA) and down-converts these signals through the L1 and L2 chains, respectively and digitizes the signal and passes it to the FPGA for signal processing.



Figure 7 – Dual Frequency GPS RF Card

B. Sounding Rocket Demonstration

The SpaceCube Navigator (Figure 8) will fly on a sounding rocket experiment in August 2015. The goal is to demonstrate acquisition and tracking of GPS L1 C/A and L2C signals. The software computes position, velocity and time (PVT) solutions based on L1 and L2C tracking data

and transmit telemetry to an external modem via an RS-422 UART interface at 57600 baud. The FPGA will also store raw GPS L1 and L2C data samples from the GPS front-end on a non-volatile Flash Memory for post-processing on the ground. This flight demonstration will increase the TRL of the Navigator on the SpaceCube platform and make it readily available for future missions.

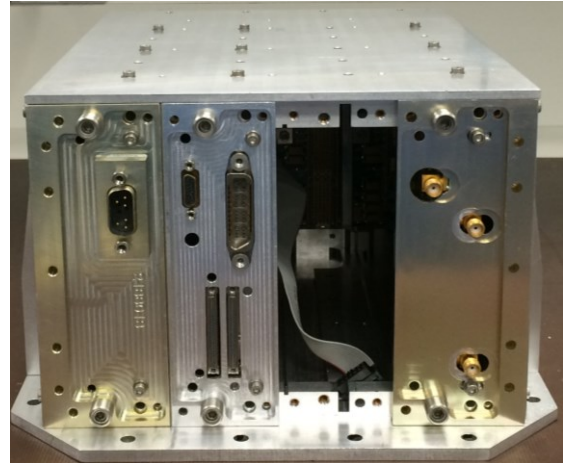

Figure 8 – GPS SpaceCube

C. Future Applications of Navigator on SpaceCube

This next generation Navigator will target high ($> 4 R_e$) and low ($< 4 R_e$) altitude missions in all orbit regimes, where R_e is the Earth's radius. Missions already using SpaceCube v2.0 for science data processing, for example, requiring a GPS receiver will have Navigator as a high-performance, low-cost option: simply add the (soon-to-be) flight-proven GPS RF front-end card to the chassis, attach an active GPS antenna, and load the Navigator software/firmware.

5. ROBOTICS APPLICATION

The Robotics Refueling Mission (RRM) is a joint effort between NASA and the Canadian Space Agency (CSA). RRM was launched on STS-135 and installed onto Express Logistics Carrier 4 (ELC4) on the ISS 2011 as shown in Figure 9.

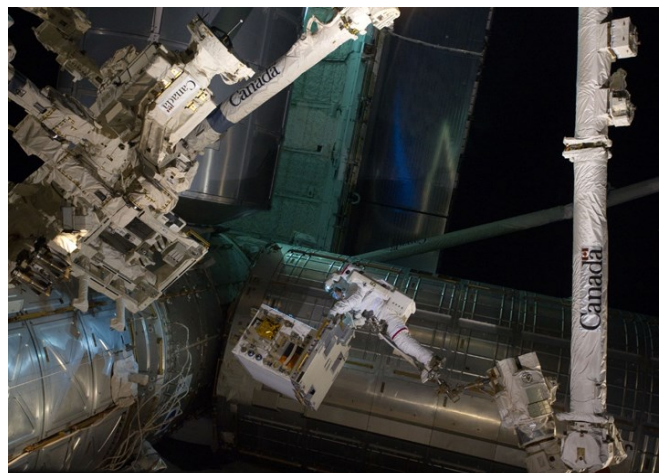

Figure 9 – RRM Installation on ISS

It is an experiment designed to develop technologies and perform demonstrations of satellite servicing tools, technologies and techniques that could be used to service legacy spacecraft. The use of the on-orbit Special Purpose Dexterous Manipulator (SPDM) will be utilized to achieve these goals [16].

A. RRM Phases 1 and 2

RRM Phase 1 (RRM1) utilized the SPDM (see example in Figure 10) to perform on-orbit demonstrations such as valve lockwire cutting, removal of various satellite valve caps, fluid transfer through and on-orbit mated valve connection, and tape cutting and thermal blanket manipulation.



Figure 10 – RRM Operations on ISS

RRM Phase 2 (RRM2) included two new task boards and one new tool that are added to the RRM modular structure. These new items provide additional capability demonstrations.

There are no centralized avionics computers for RRM1 or RRM2. Commanding was performed through the use of the discrete command channels on ELC. These channels were used to provide a control system for the components of the Fluid Transfer subsystem. For telemetry, the avionics provided an interface to allow all telemetry taken on the payload to be transmitted through the designated telemetry inputs on ELC. This system was limited on its command and telemetry capabilities due to the fixed number of available channels.

B. RRM Phase 3

RRM Phase 3 (RRM3) is the latest mission that is scheduled to launch in 2017. It will develop the technology required to store and transfer liquid cryogenics and gaseous xenon on-orbit. The RRM3 payload is divided into two modules, the Fluid Transfer Module (FTM) and the Tool Stowage Module (TSM). The avionics for RRM3 is currently located on the FTM. The RRM3 payload FTM is designed to be launched in the Dragon Trunk on the SpaceX Falcon 9 launch vehicle. The payload is compatible with the unpressurized environment of the Trunk and is to be mounted in the Trunk as Flight Release Attachment

Mechanism (FRAM) cargo. During operations on the ISS, the FTM will be mounted to an ELC, where it is provided structural, electrical, and command & data handling capabilities. Handling of the payload and its components will be done via the ISS (SPDM) Orbital Replacement Unit (ORU) Tool Changeout Mechanism (OTCM) interface. The RRM3 avionics consists of the Power Distribution Unit (PDU), Command & Data Handling (C&DH) subsystem, Situational Awareness Cameras (SAC), and the Motor Control Electronics (MCE).

Due to the relatively fast flight schedule, SpaceCube v2.0 will serve as the C&DH computer for RRM3. The SpaceCube v2.0 architecture allows for a quick turnaround development flow, compared to typical space systems that can have development cycles that can run for 3-5 years just for the Engineering Development Unit (EDU), with an additional 1-2 years for a flight unit.

The C&DH unit is primarily responsible for providing an interface for command and telemetry to go between the ELC and the payload components. The SpaceCube v2.0 platform provides RRM3 with the increased processing capabilities required to meet the following requirements:

- Increased command processing and distribution
- Reconfigurable FPGA resources to handle custom instrument interfaces
- Data storage for stored commands, command scripts, etc., and transfer data to and from onboard memory via uplink/downlink communications
- Uplink and downlink using MIL-STD-1553 data interface
- High speed downlink using 10BASE-T Ethernet data link
- Payload Analog Telemetry Collection
- Multiple subsystem interfaces including RS-422 and LVDS
- Provisions for future hardware that is added to the payload, commanding and telemetry collection

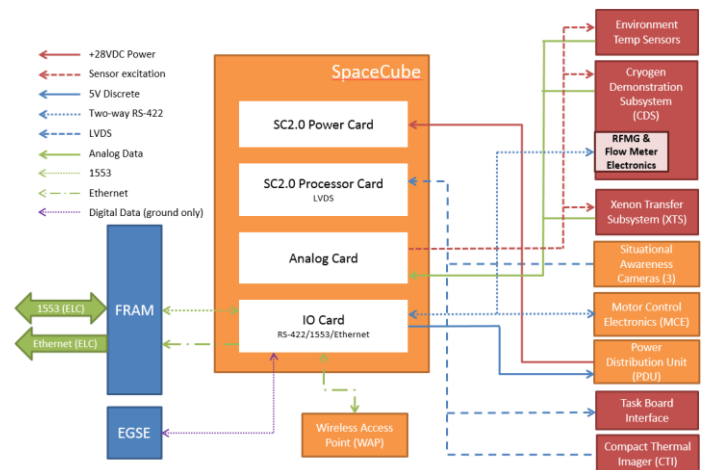

Figure 11 – RRM3 Avionics SpaceCube Interconnect

Along with the Processor, Power, and Backplane Cards, the RRM3 C&DH will have an additional two cards to meet its requirements. The block diagram of the SpaceCube avionics for RRM3 is shown in Figure 11.

C. RRM3 SpaceCube Analog Card

The Analog Card is the third card in the C&DH subsystem. The card is responsible for collecting the payload housekeeping data: thermal telemetry, internal health & status telemetry. The Analog Card data acquisition system is used to process multiple analog and digital telemetry channels from temperature sensors, pressure transducers, liquid/valve sensors, latch valves, and a flow meter.

The Analog Card uses multiplexer circuits to provide telemetry for all thermal and housekeeping channels. The multiplexer output is then sent to an Analog-to-Digital Converter, where the signal is digitized. The digitized data is then routed to the Processor Card. The Analog Card also contains the excitation circuitry required for collecting data, i.e. constant current source for temperature sensors.

D. RRM3 SpaceCube ISS Interface Card

The ISS Interface Card is the fourth card in the C&DH subsystem. It is used as the bridge between the SpaceCube Processor Card and the FRAM/ELC. The card is designed to interface with the FRAM/ELC to transmit telemetry and receive commands. Commands are received from the ELC 1553 data bus on the Interface Card and then routed to the Processor Card for processing and distribution. The Interface Card also transmits payload data, including health and status, over the MIL-STD-1553 data bus to the FRAM/ELC interface. The Interface Card also has an Ethernet interface. Operations data is transmitted to the FRAM/ELC interface through the higher speed Ethernet link. This allows for concurrent downlink transmissions. The Interface Card will leverage the SpaceCube v1.0 1553 and Ethernet circuitry that is currently on ISS [3].

The Interface Card is also the bridge between the Processor Card and other subsystems within the payload. The Interface Card contains the circuitry to communicate with all of the subsystems utilizing an RS-422 data interface. The signals are routed between the Processor and Interface Cards through the Backplane.

E. RRM3 SpaceCube System Description

For RRM3, the current Processor Card design uses one of the two Xilinx FPGAs. The FPGA is the central interface/controller on the card. Some of the main functions of the FPGA include embedded microprocessor core, reset controller, memory interface controller, software load controller, time management and distribution, and instrument/tool interface controllers.

The Flight Software (FSW) is designed to work with the FPGA design on the processing and distribution of the incoming commands, as well as collecting and transmitting

all of the telemetry. The FSW and FPGA designs will be developed using a pre-existing framework for SpaceCube that allows for quick adaptation to the new requirements. RRM3 plans to utilize the on-orbit FPGA/FSW reconfiguration infrastructure to support new instruments, tools, and test modes.

6. CONCLUSIONS

SpaceCube v2.0 fits the need for a hybrid, reconfigurable, modular space processing system.

We have shown how the modular architecture of the SpaceCube v2.0 system has been quickly adapted to meet various interface and data processing requirements. We have highlighted 3 use cases where cost, schedule, and functional requirements were made possible due to superior performance of the reconfigurable processor card that is designed to interface with custom I/O cards. In addition to the power card and processor card, we have built 6 I/O cards for the system, 5 of which have been discussed herein.

The SpaceCube v2.0 system has exceptional processing capability at relatively low power, invaluable flexibility to support on-orbit reconfiguration, mission unique plug-in cards, trending serial gigabit interfaces, and is packaged in a small form factor. As shown in the GPS case, the SpaceCube v2.0 system reduces the SWaP of a system compared to that of a traditional system using typical 6U flight processors paired with multiple anti-fuse FPGAs.

The SpaceCube is a proven technology; we have flown five missions which have successfully operated 14 commercial Xilinx FPGAs for a total of 29 device-years on orbit as of May 2015, 17 embedded PowerPCs, and 4 embedded MicroBlaze processors in space.

7. FUTURE WORK

The main near term objective is to increase the TRL-6 SpaceCube v2.0 system to TRL-7. This will be accomplished during environmental qualification testing on a dedicated unit.

The RRM-3 mission interface cards will be designed this year. The SpaceCube avionics will be integrated and tested along with required FPGA and FSW.

REFERENCES

- [1] D. Petrick, A. Geist, D. Albajes, M. Davis and P. Sparacino *et al.*, "SpaceCube v2.0 Space Flight Hybrid Reconfigurable Data Processing System," Aerospace Conference, IEEE, Big Sky, MT, 2014.
- [2] T. Flatley, "SpaceCube: A Family of Reconfigurable Hybrid On-Board Science Data Processors," presented at the NASA/ESA Conference on Adaptive Hardware and Systems, Nuremberg, Germany, June 2012.

- [3] D. Petrick, D. Espinosa, R. Ripley, G. Crum, A. Geist and T. Flatley, "Adapting the Reconfigurable SpaceCube Processing System for Multiple Mission Applications," Aerospace Conference, IEEE, Big Sky, MT, 2014.
- [4] "Space Communications and Navigation." *NASA Goddard Space Flight Center FY 2006 Internal Research and Development Program, R&D Achievements.* [On-line]. pp. 8. Available: http://gsfctechnology.gsfc.nasa.gov/2006_AR_V6_FINAL_low.pdf [Aug. 8, 2013].
- [5] "SpaceCube." *Goddard Tech Transfer News.* Spring 2009. [On-line]. 7(1), pp. 3. http://techtransfer.gsfc.nasa.gov/newsletter/springHST_09.htm [Aug. 8, 2013].
- [6] "Virtex 5 Family Overview," [On-Line]. Available: http://www.xilinx.com/support/documentation/data_sheets/ds100.pdf, Feb. 6, 2009.
- [7] D. Espinosa, A. Geist, D. Petrick, T. Flatley, J. Hosler, G. Crum, M. Buenfil, "Radiation-Hardened Processing System," U.S. Patent 8,484,590, issued July 9, 2013.
- [8] D. Petrick, "NASA Shoots SpaceCube Technology into Orbit," Xilinx Xcell Journal Customer Innovation Issue, pg. 27, 2010.
- [9] D. Petrick, "Application of SpaceCube in a Space Flight System," presented at the Military and Aerospace Programmable Logics Devices Conference, 2009.
- [10] "Materials International Space Station Experiment – 7," Internet: http://www.nasa.gov/mission_pages/station/research/experiments/653.html, Apr. 26, 2013 [Aug. 8, 2013].
- [11] "Space Test Program-Houston 4-ISS SpaceCube Experiment 2.0 (STP-H4-ISE 2.0)," Internet: http://www.nasa.gov/mission_pages/station/research/experiments/487.html, May 23, 2013 [Aug. 8, 2013].
- [12] J. Esper, "Small Rocket/Spacecraft Technology Platform," Internet: http://ses.gsfc.nasa.gov/ses_data_2011/110913_Esper.pdf, Sept. 13, 2011 [Aug. 13, 2013].
- [13] B. Stann et al. "Low-cost compact MEMS scanning lidar system for robotic applications" *SPIE 8379, Laser Radar Technology and Applications XVII, 837903 (16 May 2012).*
- [14] L. M. Winternitz, W. A. Bamford, and G. W. Heckler, "A GPS receiver for high-altitude satellite navigation." *IEEE Journal of Selected Topics in Signal Processing*, Vol. 3 No. 4, pp. 541-556, 2009.
- [15] D. Petrick, "SpaceCube: Current Missions and Ongoing Platform Advancements," presented at the Military and Aerospace Programmable Logics Devices Conference, 2009.
- [16] "Robotic Refueling Mission," [On-line]. http://ssco.gsfc.nasa.gov/robotic_refueling_mission.html [Aug. 22, 2013].
- [17] "MMS Mission Highlights," [On-line]. http://mms.gsfc.nasa.gov/mission_highlights.html [Mar. 19, 2015].

BIOGRAPHY



David Petrick started his career at NASA in 2000. He has a wide range of experience building Xilinx FPGA-based systems for space flight including FPGA design, radiation mitigation testing, PCB design, reconfigurable system design, and mission operations. He was the lead design engineer on the

SpaceCube v1.0 and v2.0 processor cards including embedded systems framework, FPGA core development, and electrical design, responsible engineer for the Relative Navigation Sensors SpaceCube system build, delivery, and shuttle payload operations, lead engineer for the MISSE-7 and ISE2.0 SpaceCube hardware deliveries, and systems lead on the SpaceCube v2.0 development effort. He is currently the Principal Engineer within the Science Data Processing Branch and SpaceCube Program Technical Development Lead. He has a BSEE from the University of Pittsburgh and a MSEE from the Johns Hopkins University.



Nat Gill started his career at NASA in 2000. He has designed and built space flight electronics cards and systems, as well as FPGA designs for LRO, LCROSS, GPM, and FASTSAT. His software and FPGA design experience includes controls, signal processing, and machine vision algorithm design and acceleration for the Satellite

Servicing Capabilities Office at GSFC. He is currently the lead engineer of a LiDAR based pose estimation algorithm called Flash Pose, FPGA acceleration for GNIFIR optical pose estimation, and the GRSSLi development effort. He has a BS in Electrical and Computer Engineering from The Ohio State University and a MSECE from Johns Hopkins University.



Dr. Munther Hassouneh is an engineer at NASA GSFC in the Components and Hardware Systems branch. He is the SEXTANT Demonstration ground testbed lead and is a member of the space-GPS receiver research and development group. He received his Ph.D. (2003) in

Electrical Engineering from the University of Maryland, College Park.



Robert Stone started his career at NASA in 2001. He has experience on several missions as a designer for Command & Data Handling (C&DH) and Power Supply Electronics (PSE) subsystems. His electrical design experience covers digital circuit board design, FPGA design, and analog circuit

design. He currently serves as the C&DH Lead for both RRM3 and the Magnetospheric MultiScale (MMS) missions. He was the lead design engineer for the MMS C&DH Processor Card, as well as the Principal Investigator on a LEON3 microprocessor IRAD design. He previously served as a technical consultant on the Independent Assessment Team for the GLORY mission. He also served as a lead board and FPGA designer for the Lunar Reconnaissance Orbiter (LRO) PSE subsystem, as well as lead test engineer for the Space Technology 5 (ST-5) C&DH subsystem. He has a BSEE from the University of Cincinnati.



Luke Thomas has worked as an FPGA design engineer for 15 years. He started at NASA in 2009 working on satellite modem technology, specifically Software Defined Radio implementations for the Space Network. Currently, he is working on Navigator, a GPS L1 & L2C Receiver in order to

expand the receiver's capability and migrate the algorithms to modern hardware platforms. He is also serving as firmware lead on GRSSLi (Goddard's Reconfigurable Solid-State Scanning LiDAR). He has a BSEE from Cornell University and an MSEE from Northeastern University.



Milton Davis started his career at NASA in 2000. He has experience on several missions serving as an attitude control system contracting officer's technical representative (COR) and component hardware lead for star tracker systems. In this role he is acting as the technical authority and liaison between the

project and external vendor and is responsible for the requirement development, selection, procurement, oversight, and integration and test activities of the system onto the spacecraft. He also has design, analysis, assembly, and integration and testing, experience as the component and chassis assembly level. He has served as the packaging lead for GPS processor, GPS RF, power, command and data handling, and propulsion deployment electronic systems. He is a co-lead for the NASA-wide Avionics Community of Packaging Sub-committee (CoSP). He is currently serving as the electronics packaging lead for SpaceCube v2.0. He has a BS in aerospace and aeronautical engineering from Purdue University and a MS in project/ technical management from the Johns Hopkins University.

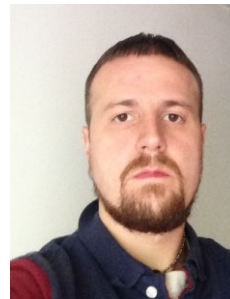

Pietro Sparacino started his career at NASA in 2003. His electrical design experience covers a variety of disciplines, including mixed-signal circuit board designs, power design, FPGA design, control loops, and PCB design. He also has experience in verification and validation, parts engineering,

reliability engineering. In the past he served as the lead design engineer for the COTS/CRS C&DH Power Supply Unit, and the ARGON Power Control Unit. He is currently the lead design engineer for the SpaceCube v2.0 Power Card, and the responsible engineer for the LCRD Modem Digital Board. He has a BSEE from the University of Maryland College Park, and is working toward an MSEE from the Johns Hopkins University.



Tom Flatley is a Computer Engineer at the NASA Goddard Space Flight Center, and is currently Branch Head of the Science Data Processing Branch. Prior to this period he developed numerous flight and ground components and subsystems for various NASA missions, beginning in 1985. Mr. Flatley's

current work includes the coordination of embedded science data processing technology development and hardware accelerated science data processing activities, serving as Principal Investigator on multiple flight

processing experiments, with the primary goal of developing re-configurable computing technology and hybrid systems for flight and ground science data processing applications. He is also a key member of the GSFC CubeSat/SmallSat technology working group, manages numerous collaborations with government, industry and academic partners, and serves as liaison between technology developers and end users in the science community. Mr. Flatley received a 2011 NASA “Exceptional Engineering Achievement Medal”, the 2012 American Astronautical Society “William Randolph Lovelace II Award” and the 2013 Goddard “Innovator of the Year” award for advancing spaceflight and space exploration technology through the development of SpaceCube.