

Loop Heat Pipe Temperature Oscillation Induced by Gravity Assist and Reservoir Heating

Jentung Ku¹, Matthew Garrison², Deepak Patel³, Franklin Robinson⁴ and Laura Ottenstein⁵
NASA Goddard Space flight Center, Greenbelt, Maryland 20771

The Laser Thermal Control System (LTCS) for the Advanced Topographic Laser Altimeter System (ATLAS) to be installed on NASA's Ice, Cloud, and Land Elevation Satellite (ICESat-2) consists of a constant conductance heat pipe and a loop heat pipe (LHP) with an associated radiator. During the recent thermal vacuum testing of the LTCS where the LHP condenser/radiator was placed in a vertical position above the evaporator and reservoir, it was found that the LHP reservoir control heater power requirement was much higher than the analytical model had predicted. Even with the control heater turned on continuously at its full power, the reservoir could not be maintained at its desired set point temperature. An investigation of the LHP behaviors found that the root cause of the problem was fluid flow and reservoir temperature oscillations, which led to persistent alternate forward and reversed flow along the liquid line and an imbalance between the vapor mass flow rate in the vapor line and liquid mass flow rate in the liquid line. The flow and temperature oscillations were caused by an interaction between gravity and reservoir heating, and were exacerbated by the large thermal mass of the instrument simulator which modulated the net heat load to the evaporator, and the vertical radiator/condenser which induced a variable gravitational pressure head. Furthermore, causes and effects of the contributing factors to flow and temperature oscillations intermingled.

Nomenclature

ATLAS	=	Advanced Topographic Laser Altimeter System
CC	=	compensation chamber
CCHP	=	constant conductance heat pipe
g	=	accelerating force due to gravity
H	=	vertical distance between the reservoir and the condenser at the top of the radiator
z	=	vertical distance between the reservoir and vapor front inside the condenser
ICESat	=	Ice, Cloud, and Land Elevation Satellite
LHP	=	loop heat pipe
LTCS	=	Laser Thermal Control System
\dot{m}	=	mass flow rate
NASA	=	National Aeronautics and Space Administration
Q_{cc}	=	heat applied to reservoir
Q_E	=	heat applied to evaporator
Q_{leak}	=	heat leak from the evaporator to the reservoir
Q_{Rad}	=	heat leak from the reservoir to the radiator
Q_{sub}	=	subcooling of liquid entering the reservoir
R	=	radius of curvature of meniscus of the liquid and vapor interface
T_{cc}	=	saturation temperature of the fluid in the reservoir
T_E	=	evaporator temperature
T_{in}	=	temperature of liquid at the reservoir inlet

¹ Lead Aerospace Engineer, Thermal Engineering Branch, NASA Goddard Space Flight Center, Greenbelt, MD.

² Lead Aerospace Engineer, Thermal Engineering Branch, NASA Goddard Space Flight Center, Greenbelt, MD.

³ Aerospace Engineer, Thermal Engineering Branch, NASA Goddard Space Flight Center, Greenbelt, MD.

⁴ Aerospace Engineer, Thermal Engineering Branch, NASA Goddard Space Flight Center, Greenbelt, MD.

⁵ Lead Aerospace Engineer, New Opportunities Office, NASA Goddard Space Flight Center, Greenbelt, MD.

TV	=	thermal vacuum
ΔP_g	=	Gravitational pressure head
λ	=	latent heat of vaporization of the working fluid
ρ_l	=	density of liquid of the working fluid
ρ_v	=	density of vapor of the working fluid

I. Introduction

THE second Ice, Cloud, and Land Elevation Satellite (ICESat-2) mission currently planned by the National Aeronautics and Space Administration (NASA) will measure global ice topography and canopy height [1]. The mission requires a micropulse space flight laser system, called Advanced Topographic Laser Altimeter System (ATLAS). The ATLAS comprises two lasers; but only one will be used at a time. Each laser will generate between 136W and 196W of heat during its operation, and each laser has its own optimal operating temperature that must be maintained within $\pm 1^\circ\text{C}$ accuracy by the ATLAS Laser Thermal Control System (LTCS) consisting of a constant conductance heat pipe (CCHP) and a loop heat pipe (LHP) with an associated radiator as shown in Figure 1. The CCHP is attached to the two lasers at its evaporator end, and to the LHP evaporator at its condenser end. Thus, heat generated by the lasers is acquired by the CCHP and transferred to the LHP, which delivers the heat to the radiator for ultimate rejection to space. Both the CCHP and LHP use ammonia as the working fluid.

During LTCS thermal vacuum (TV) testing, it was found that the LHP reservoir control heater power requirement was much higher than the analytical model had predicted. The required control heater power was also much higher than the liquid subcooling entering the reservoir using the measured temperatures and the calculated mass flow rate based on steady state LHP operation. Even when the control heaters were turned on continuously at full power, the reservoir could not reach its set point temperature. Consequently, the instrument simulator was below its desired operating temperature.

An investigation of the LHP behaviors found that the root cause of the problem was fluid flow and reservoir temperature oscillations, which led to persistent alternate forward and reversed flow along the liquid line and an imbalance of the vapor mass flow rate in the vapor line and liquid mass flow rates in the liquid line. The flow and temperature oscillations were caused by an interaction between gravity and reservoir heating, and were exacerbated by the large thermal mass of the instrument simulator which modulated the net heat load to the evaporator, and the vertical radiator/condenser which induced variable gravitational pressure head. Furthermore, the causes and effects of the contributing factors to flow and temperature oscillations intermingled.

In the following discussions, some relevant theoretical backgrounds are presented first. This is followed by a theory that explains the underlying physical processes that lead to persistent fluid flow and temperature oscillations. Experimental results from the ATLAS LTCS TV testing relevant to flow and temperature oscillations are reviewed. Ways to overcome the high control heater power problem in TV testing of gravity-assist LHP are also discussed.

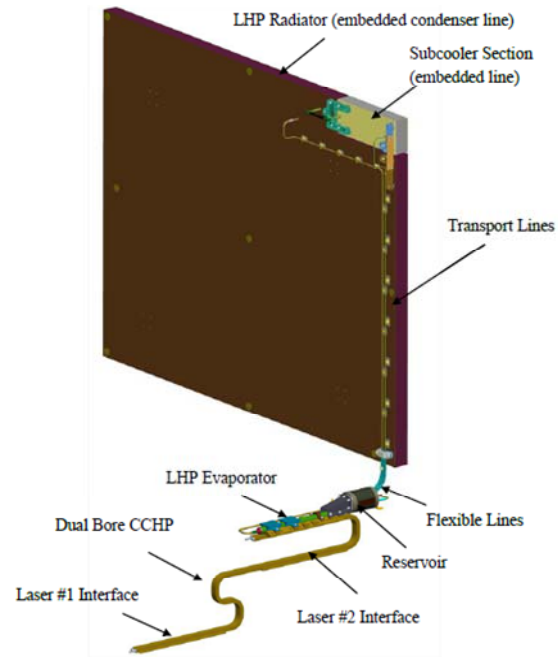

Figure 1. Schematic ATLAS TCS

II. Theoretical Backgrounds

2.1 Pressure Drop in LHP Operation

LHPs have been used on many orbiting spacecraft for thermal control [2-9]. In the normal LHP operation, the total pressure drop to be sustained by the evaporator wick is the sum of viscous pressure drops in vapor grooves, vapor line, condenser, liquid line, and primary wick, plus any possible gravitational pressure head [10-14], i.e.

$$\Delta P_{\text{cap}} = \Delta P_{\text{tot}} = \Delta P_{\text{groove}} + \Delta P_{\text{vl}} + \Delta P_{\text{cond}} + \Delta P_{\text{ll}} + \Delta P_{\text{wick}} - \Delta P_{\text{g}} \quad (1)$$

$$\Delta P_{\text{cap}} = 2\sigma \cos\theta / R \quad (2)$$

$$\Delta P_{\text{g}} = (\rho_l - \rho_v)g\Delta H \quad (3)$$

Note that ΔH is the height difference measured from the condenser to the evaporator in the gravity field, and is positive when the condenser is above the evaporator and negative when the condenser is below the evaporator.

Pressure drop diagrams showing the pressure profiles along the LHP elements under gravity-neutral, anti-gravity and gravity-assist configurations with a horizontal condenser have been presented [15]. In LTCS TV testing, the radiator is placed in a vertical configuration and the condenser has multiple horizontal and vertical segments as shown in Figure 2. The vapor from the evaporator enters the condenser at the top of the radiator (orange color) and travels downward through the horizontal and vertical segments of the condenser. After vapor reaches the horizontal segment at the bottom, it moves upward along a vertical segment before entering the last horizontal segment and leaving the subcooler (blue color). The gravitational pressure head is not constant, and will vary with the position of the vapor front. This is further illustrated in Figure 3. If the liquid-filled subcooler is at a height of H above the reservoir, and the vapor front inside the condenser is located at a height of z below the subcooler, then $\Delta H = H - z$. Thus, when the vapor front is at the top of the radiator, the gravitational pressure head is at its maximum. As the vapor front moves downward in the vertical direction, the gravitational pressure head decreases, and reaches its minimum when the vapor front is at the bottom of the radiator. As will be discussed later, the movement of the vapor front and its location has a direct impact on the flow and temperature oscillations.

2.2 Energy Balance in the Reservoir

In a gravity-neutral LHP operation, the energy balance for the reservoir requires that the subcooling of the returning fluid be compensated for by the heat leak from the evaporator to the reservoir plus the external reservoir control heater power:

$$Q_{\text{cc}} = Q_{\text{sub}} - Q_{\text{leak}} \quad (4)$$

$$Q_{\text{sub}} = \dot{m} C_p (T_{\text{cc}} - T_{\text{in}}) \quad (5)$$

$$\dot{m} = (Q_E - Q_{\text{leak}}) / \lambda \quad (6)$$

Under steady state, the vapor mass flow rate in the vapor line and the liquid mass flow rate in the liquid line are the same, and can be calculated from Equation (6). With flow and temperature oscillations under the gravity-assist LHP operation, the flow is never steady and the vapor and

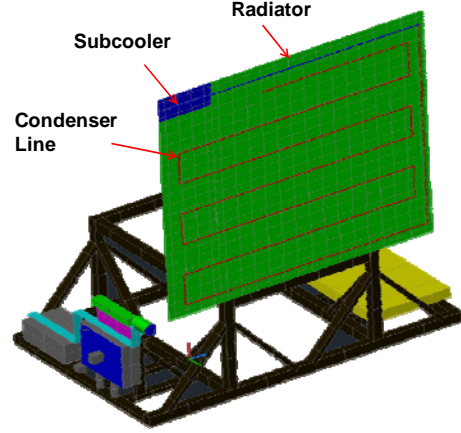

Figure 2. The Vertical Radiator

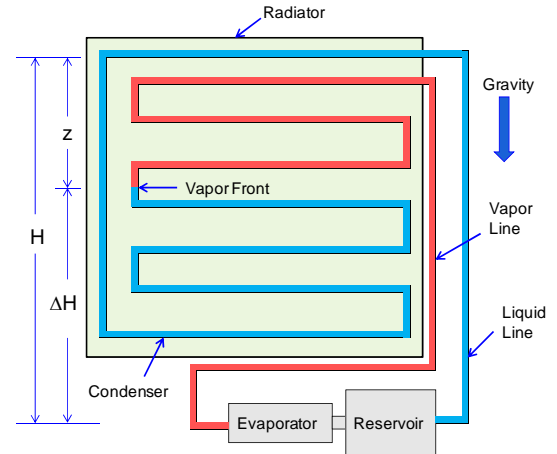

Figure 3. Gravitational Pressure Head in LHP with Vertical Condenser

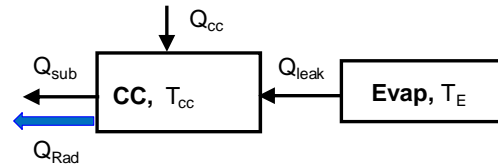

Figure 4. Reservoir Energy Balance

liquid mass flow rates are not equal. When the reservoir temperature is decreasing, the net heat input to the evaporator is increasing and the vapor front advances inside the condenser. Thus, the liquid mass flow rate is much higher than that based on the externally applied heat to the evaporator under steady state. When the reservoir temperature is rising at a faster rate than that of the evaporator, liquid will flow in an opposite direction along the liquid line. The reverse liquid flow carries some of the reservoir control heater power to the condenser/radiator. Thus, the reservoir has an additional “heat leak” to the condenser when the reservoir temperature is oscillating. In Figure 4, Q_{Rad} represents the additional heat leak from the reservoir to the radiator due to the constant ingress of cold liquid from the radiator and egress of warm liquid to the radiator when compared to the steady state operation. This additional heat leak from the reservoir to the radiator results in a very high reservoir control heater power that is required to maintain the reservoir set point temperature. As will be explained later, if the reservoir set point cannot be maintained with the full control heater power, flow and temperature oscillations will persist.

2.3 Flow and Temperature Oscillations with Gravity Assist

The underlying physical processes during the fluid flow and temperature oscillations, including interactions among various elements of the LHP, are detailed below.

2.3.1 Reservoir Temperature Decreasing

When the reservoir temperature begins to decrease, it creates some chain effects. First, the evaporator temperature will also decrease. Second, a larger temperature gradient between the thermal mass and the evaporator causes the thermal mass to release its sensible heat. Hence, the net heat input to the evaporator is greater than the externally applied power. Third, the vapor front in the condenser will advance farther downstream, displacing an equal volume of liquid toward the reservoir. Because of the large difference in the liquid and vapor densities, the liquid mass flow rate in the liquid line is much higher than that during steady state. Fourth, the additional liquid volume feeding into the reservoir causes the reservoir temperature to decrease further. Fifth, a decreasing reservoir temperature accelerates the above-mentioned events. In the meantime, the reservoir control heater is heating the reservoir with its full power continuously.

The accelerating reservoir temperature drop cannot continue forever because of some counter-balancing forces: 1) The higher liquid mass flow rate increases the viscous pressure drops in the condenser and liquid line; 2) As the vapor front advances downstream of the condenser, the gravitational pressure head decreases due to a decrease of the ΔH term in Equation (3). A decreasing gravitational pressure head slows down the liquid flow rate along the liquid line. This in turn slows down the rate of reservoir temperature drop. Furthermore, there is also an inertia effect. Because the vapor advances in the same direction as its regular flow, such an advance usually overshoots. This is true even under the horizontal configuration. Gravity assist simply enhances such an effect. At some point, the advance of the vapor front will stop because only a certain length of the condenser is needed for vapor condensation as required by energy balance. When the vapor length reaches its maximum, ΔP_g is at its minimum. Figure 5 shows that the vapor length reaches its maximum at location F_1 inside the condenser. At the same time, the reservoir temperature is near its minimum. As soon as the vapor front stops advancing and starts receding, all of the chain effects mentioned above simply diminish. Because the reservoir control heater is still on, the reservoir temperature starts to increase.

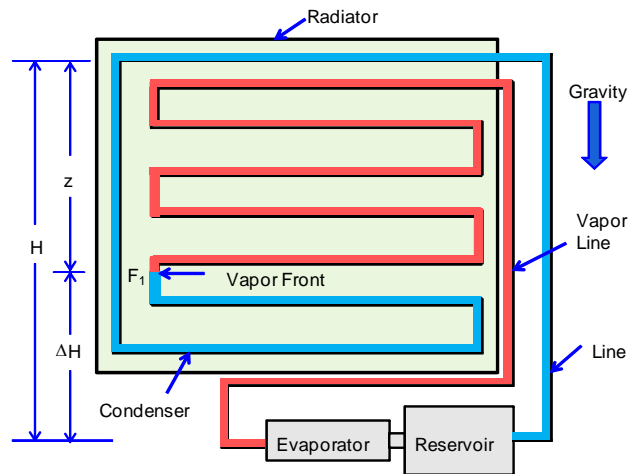

Figure 5. Vapor Length at Its Maximum Value

2.3.2 Reservoir Temperature Increasing

As the reservoir temperature is increasing, the net heat input to the evaporator from the thermal mass is decreasing, leading to the recession of the vapor front in the condenser. The flow in the liquid line will reverse because additional liquid is fed from the reservoir via the liquid line to fill the space in the condenser left by the

vapor recession. Under this circumstance, the forward vapor flow in the vapor line and the reverse liquid flow in the liquid line coexist.

The reverse liquid flow works against gravity. Hence, the rate of vapor front recession is slower than that in the horizontal configuration under the same condition. It is also slower than the vapor advance when the reservoir temperature is decreasing. As the vapor length in the condenser decreases, the gravitational pressure head, ΔP_g , increases, further slowing down the rate of the reverse liquid flow. Unless the reservoir control heater power is sufficiently large to shut down the loop, the vapor length in the condenser would reach its minimum because some vapor length is needed as long as there is heat load entering the condenser from the vapor line. Thus, the vapor length reaches its minimum value and the vapor front will be located at F2 shown in Figure 6. As soon as the vapor front stops receding and starts advancing, cold liquid is injected into the reservoir and the reservoir temperature will drop rapidly. This starts the next cycle of reservoir temperature decrease and increase described above.

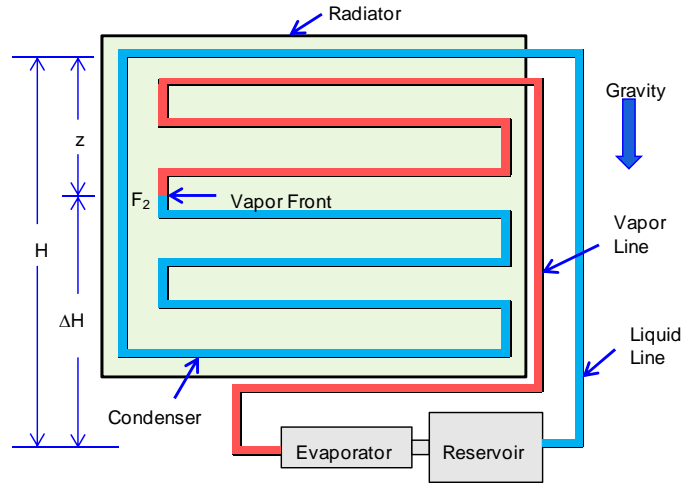

Figure 6. Vapor Length at Its Minimum Value

2.3.3 Sustaining Flow and Temperature Oscillations

From above descriptions, main contributions to fluid flow and temperature oscillations in ATLAS LTCS TV testing are: 1) a large favorable gravitational pressure head due to gravity assist; 2) a very cold radiator relative to the reservoir temperature; 3) a large reservoir temperature drop due to an influx of cold liquid from the condenser; 4) inability of the reservoir control heater to raise the reservoir temperature to its set point; 5) a large thermal mass which modulates the net heat input to the evaporator due to the release and storage of its sensible heat as the reservoir temperature oscillates; 6) a large vapor front movement in the condenser due to changes in the net heat input to the evaporator and the reservoir temperature; 7) a reverse liquid flow when the reservoir temperature rises at a faster rate than the evaporator temperature; and 8) a vertical radiator/condenser which results in variable gravitational pressure head as vapor moves along the vertical direction of the condenser. It is seen that some of the causes and effects of fluid flow and temperature oscillations intermingle.

One critical factor that allows flow and temperature oscillations to persist is the inability of the control heater to bring the reservoir temperature to its set point. The valley of the oscillating reservoir temperature is determined primarily by the temperature of the returning liquid, the liquid mass flow rate during transient (how fast the vapor front advances), and the amount of cold liquid being brought into the reservoir (the range of the vapor front advance/recession in the condenser). The peak of the oscillating reservoir temperature is determined mainly by the control heater power and the mass flow rate of the reverse liquid flow. If the peak of the oscillating reservoir temperature cannot exceed its set point temperature, the temperature will begin to decrease when cold liquid enters the reservoir again due to gravity in the next cycle of the temperature oscillation. In essence, a constantly changing reservoir temperature leads to a constantly moving in a constantly moving vapor front. A change in the vapor front

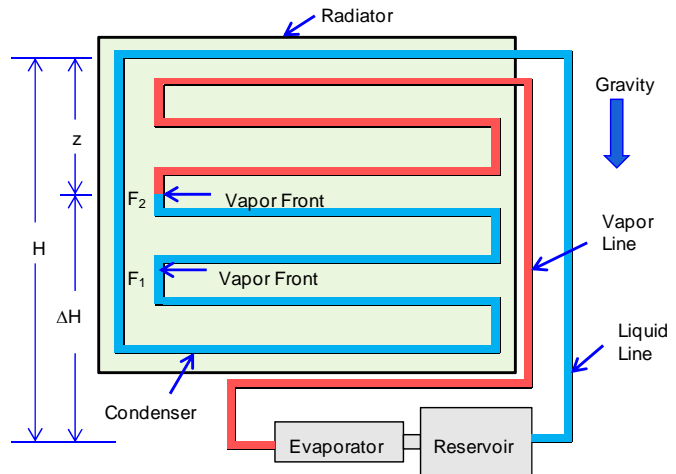

Figure 7. Vapor Front Moves Back and Forth between F₁ and F₂

position inside a vertical condenser leads to a variable gravitational pressure head. The large thermal mass further modulates the net heat load to the evaporator as the reservoir temperature changes. Furthermore, the reservoir is continuously being heated by its control heater. All the factors combined lead to persistent liquid flow and reservoir temperature oscillations. The causes and effects of the oscillations even intermingle. Figure 7 shows the vapor front moves between locations F1 and F2 during each cycle of the flow and temperature oscillations.

If the peak of the oscillating reservoir temperature can exceed the reservoir set point, the heater will be turned off for a period of time. An unchanging reservoir temperature will allow the thermal mass to settle toward its equilibrium temperature. It will also allow the vapor front to settle toward its equilibrium position inside the condenser. When the reservoir temperature drops below its set point and the heater is turned on, a reverse liquid flow will still happen. However, the vapor front will move more slowly and over a shorter distance compared to the case with a constantly changing reservoir temperature. Therefore, the amount of the cold liquid being injected into the reservoir will be small and the control heater will be able to bring the reservoir temperature to its set point quickly. There will be no rapid and sometimes prolonged influx of cold liquid into the reservoir. Hence, the intermittent “off” periods of the control heater could prevent the persistent fluid flow and temperature oscillations.

The fluid flow and temperature oscillations will also disappear if the control heater power is reduced to zero because there is no longer a driving force to cause a reverse flow along the liquid line. The loop will then operate at its natural operating temperature, which will most likely be too low for the instrument.

III. Test Results in LTCS TV Testing

3.3 Test Setup

Figure 8 depicts the schematic of the setup of the LTCS in TV testing. Two thermal masses simulating the two lasers were attached to the CCHP, which transported heat from the thermal masses to the LHP evaporator. The LHP evaporator and reservoir were at a horizontal position and the radiator/condenser was placed vertically. The top and bottom of the condenser were 1150 mm and 158.3 mm higher than the reservoir/evaporator, respectively. Each thermal mass had cartridge heaters which provided variable heat loads. Figure 9 shows that two sets of control heaters were installed on the reservoir; each consisted of two adjacent heaters. The two heaters on the same set were controlled by the same temperature sensor (either TCS-10 or TCS-11), but their set points were 1 °C apart. Hence the two heaters could be both on, both off, or one on and one off.

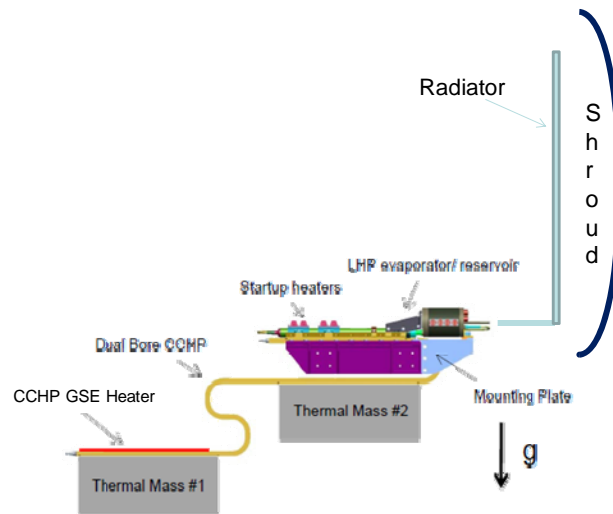

Figure 8. Schematic of Test Setup of ATLAS LTCS TV Testing

Figure 9 also shows the other flight temperature sensors (thermistors) on the evaporator (TCS-15), vapor line (TCS-17) and liquid line at the reservoir inlet (TCS-16). In addition to flight thermistors, several thermocouples were installed on the LTCS for TV testing. Figure 10 shows the thermocouples installed on the radiator itself, which closely followed the foot prints of the serpentine condenser line.

The LTCS TV testing included several thermal balance tests, which can be used to verify the above theory for temperature oscillation in the LHP operation with gravity assist. Unfortunately, the theory cannot be fully verified with the LTCS test data for the following reasons: 1) there were no temperature sensors installed directly on the condenser. Hence, the vapor front movement inside the condenser cannot be tracked. Without the knowledge of the vapor front movement inside the condenser, the actual mass flow rate along the liquid line and the mass and energy balance in the reservoir cannot be analyzed. 2). The TV test facilities provided one set of temperature data

every two minutes, which was adequate for test monitoring but was too slow for studying the LHP behaviors during fast transients.

Nevertheless, relevant data from the LTCS thermal balance test can still be used to provide partial verification of the theory. In particular, the two temperature sensors on the reservoir, TCS-10 and TCS-11, were connected to a different data acquisition system which updated the data once every 4 seconds. These temperatures, in combination with other test data, provided valuable insights into LHP transient behaviors.

During the thermal balance test, two different heat loads (136W and 196W) were applied to the thermal mass to simulate the low and high heat outputs from the instrument. Likewise, two radiator sink temperatures (-101°C and -78 °C) were used to simulate the radiator environmental temperature during the flight. In order to keep the thermal mass at 25 °C, the set point temperatures for the two reservoir control heaters were kept at +4 °C/+5 °C with 136W heat load, and at -2 °C/-1 °C with 196W heat load, respectively. The analytical model predicted that 11W reservoir control heater power would be sufficient to maintain the desired reservoir temperature under all combinations of heat load and radiator sink temperature. Because each control heater could provide up to 11W of power, there was a minimum of 100 percent margin on the control heater power.

As the thermal balance test proceeded, it was soon realized that the reservoir set point temperature could not be reached even with both control heaters turned on continuously at their full power of 11W each (22W total). Instead, the reservoir temperature oscillated, which in turn drove other temperatures to oscillate. Experimental results of some tests are presented below.

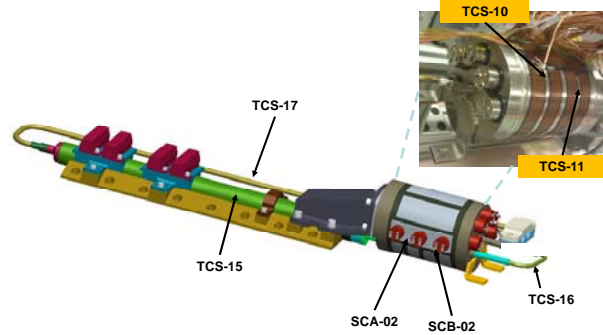

Figure 9. Some Temperature Sensors on the LHP

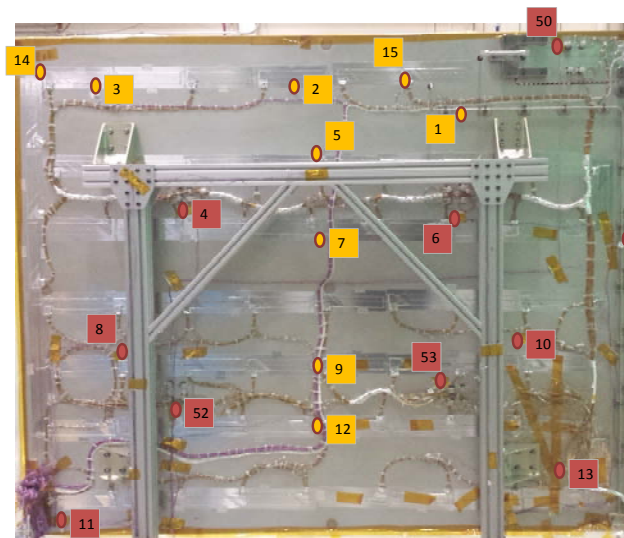

Figure 10. Thermocouples on the Radiator

3.2 Test #1: Cold Transition at 136W Heat Load and -101°C Sink

According to the theory presented earlier, if the LHP is not shut down and the temperature oscillation persists, the forward vapor flow in the vapor line and the reverse liquid flow in the liquid could coexist when the reservoir temperature is rising.

Figure 11 shows the loop temperature profiles during the cold transition where the TV chamber shroud temperature was transitioning from 0°C to -101°C. The thermal mass 1 had a heat load of 136W, and the two reservoir control heaters with 11W each had set points of +4 °C and +5 °C, respectively. For clarity, only a small duration of the transition period is presented. Because the initial temperature of the reservoir was higher than its quasi-steady temperature, the reservoir temperature continued to decrease toward its quasi-steady temperature. Amidst the persistent temperature oscillation, alternate forward and reverse liquid flow along the liquid line did occur as evidenced by temperatures of the liquid line at inlet of the reservoir (TC16) and at the exit of the condenser/radiator (Radiator LL).

It is clear that the energy loss to the incoming subcooled liquid during the half cycle when the reservoir temperature was decreasing was more than the energy provided by the reservoir control heaters during the other half cycle when the reservoir temperature was increasing. Hence, the reservoir temperature continued to decrease toward its quasi-steady temperature. Note the data collection rate was once every two minutes.

3.2 Test #2: Cold Soak at 136W Heat Load and -101°C Sink

Figure 12 shows the temperature profiles of the loop components during a cold soak test which followed the cold transition test shown in Figure 11. The chamber shroud was maintained at -101°C, thermal mass 1 had a heat load of 136W, and the two reservoir control heaters with 11W each had set points of +4°C and +5°C, respectively. Even with both control heaters on (22W total), the heater set point temperatures could not be reached. Instead, a quasi-steady state was established where the peak and valley of reservoir temperature were about -23°C and -25°C and unchanging. The rise and fall of the temperature of the liquid line near the reservoir (TCS-16) in tandem with the reservoir temperature indicated that a forward and reverse liquid flow occurred alternately along the liquid line, especially for the fact the maximum liquid line temperature was near the reservoir saturation temperature. The rise and fall of the temperature on the liquid line close to the condenser/radiator exit (Radiator LL) further supported this argument.

Without the temperature oscillation, the analytical model predicted that the reservoir set point could be maintained at +5°C with 11W of heater power. The experimental data showed that, with a total of 22W heater power, the reservoir quasi-steady temperature oscillated between -23°C and -25°C, and the instrument simulator was at -14 °C, much lower than the desired operating temperature of +15°C. The profound impact of the gravitational force on the LHP operation was quite evident.

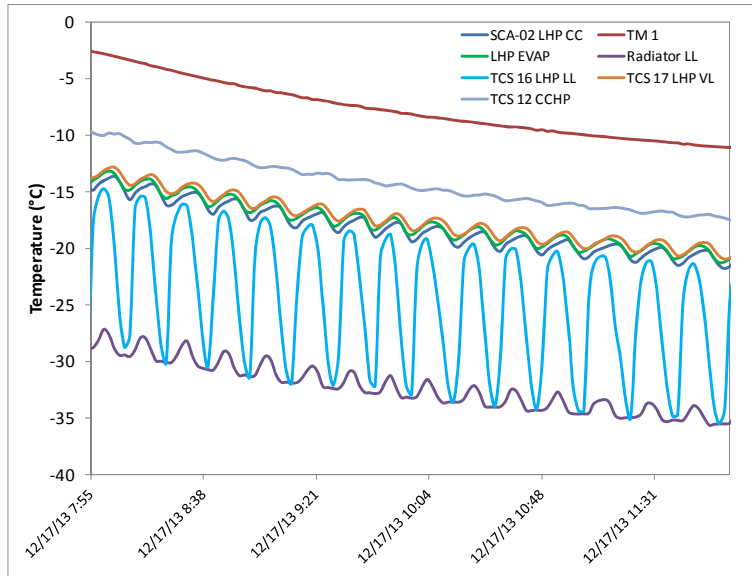

Figure 11. Oscillating Reservoir Temperature during Cold Transition Test

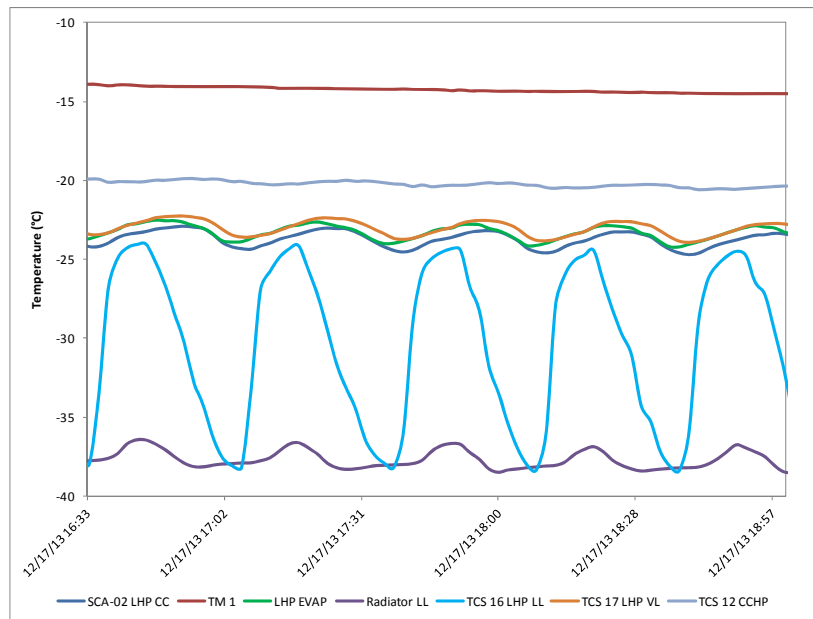

Figure 12. Oscillating Reservoir Temperature during Quasi-Steady State

3.3 Reservoir Temperatures at High Data Rate

During the quasi-steady state shown in Figure 12, the net energy loss in the half cycle when the reservoir temperature was decreasing equals the net energy gain during the other half cycle when the reservoir temperature was increasing. However, the oscillating temperature was not symmetric because the rate of temperature decrease was not the same as the rate of temperature increase. When the reservoir temperature decreased from its peak, gravity assist enhanced the liquid flow rate. When the reservoir temperature rose from its valley, the reverse flow moved against gravity, and the rate of the reverse flow was smaller than that of the forward flow. Therefore, the reservoir temperature dropped more quickly than it rose. Such a difference is visible from Figure 12 with a data collection rate of once every 2 minutes. Figure 13 shows the reservoir temperature with a data collection rate of once every 4 seconds from another data acquisition system. For clarity, a much smaller time period was selected. Note that TCS-11 was farther away from the control heaters and was a better indication of the reservoir saturation temperature than TCS-10 in this test. The temperature oscillation had a period of ~57 seconds. It took 24 seconds for the reservoir temperature to drop from its peak to valley, and 33 seconds to rise from its valley to peak.

Figure 14 shows the reservoir temperature during a portion of the cold transition shown in Figure 11. Again, it took the reservoir 24 seconds to drop from its peak temperature to the valley, and 33 seconds to rise from its valley to the peak. The peak and valley continued to drop toward quasi-steady values from one cycle to the next.

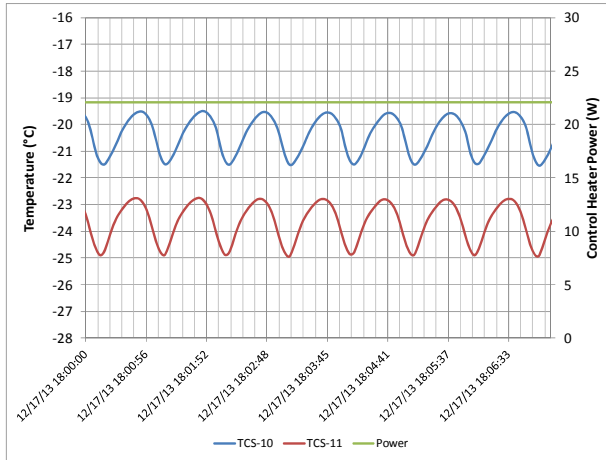

Figure 13. Reservoir Temperature during Quasi-Steady State

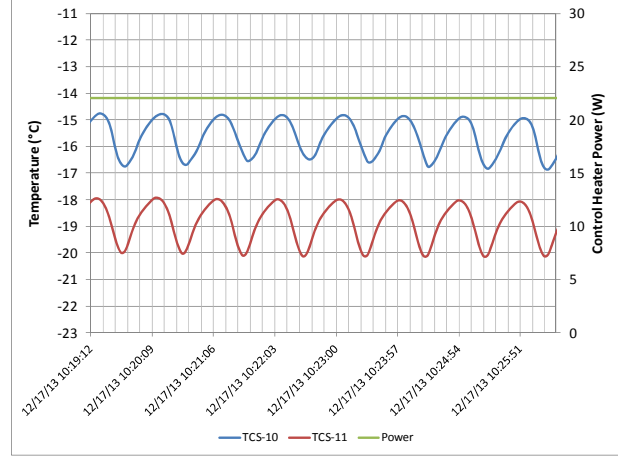

Figure 14. Oscillating Reservoir Temperature during Cold Transition

Because the period of the reservoir temperature oscillation in Figures 13 and 14 was close to 1 minute (57 seconds to be exact), temperatures recorded at a 2-minute rate could still show very similar patterns of temperature oscillation recorded at a 4-second rate.

3.4 Test #4 and Test #5: Cold Soak at 196W Heat Load and -78°C Sink Temperature

Figure 15 Shows the temperature profiles of another cold soak test (Test #4) where the chamber shroud was maintained at -78°C, thermal mass 1 had a heat load of 196W, and the two reservoir control heaters with 11W each had set points of -2°C and -1°C, respectively. The temperature profiles were very similar to those shown in Figure 12 in that the temperature oscillation persisted and the forward and reverse flow along the liquid line alternated. The reservoir temperature oscillated between -8.5°C and -6.5°C, below the set point temperature of -1°C even with full control heater power of 22W.

To investigate whether a higher reservoir control heater power could heat the reservoir to its set point temperature, thereby stopping the temperature oscillation, the control heater power was increased to 19W each by increasing the voltage from 26 volts to 34 volts, which corresponded to the expected minimum and maximum voltages of the power supply during the lifetime of the flight. The temperature profiles in this test (Test #5) are shown in Figure 16, which had quite a different pattern than that shown in Figure 15. A further examination indicated that in Test #4 with both heaters at 11W (22W total), the reservoir set point temperature of -2°C was never reached, as shown in Figure 17. On the other hand, with 19W to each control heater, one of the heaters reached the

set point temperature of -2°C periodically, as shown in Figure 18. Note that Figure 16 and Figure 18 had different data collection rates (once every 2 minutes versus once every 4 seconds).

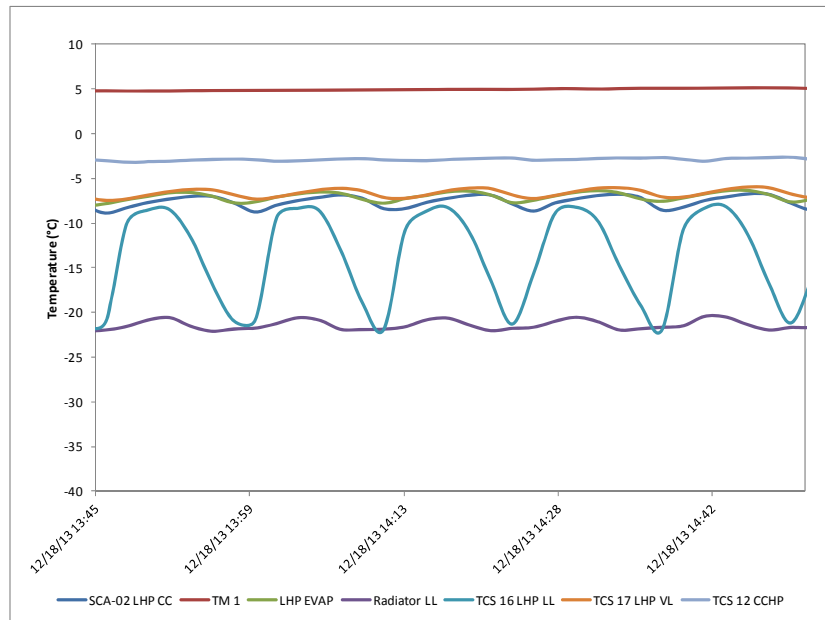

Figure 15. Oscillating Temperatures during Quasi-Steady State with 196W and -78°C Sink Temperature

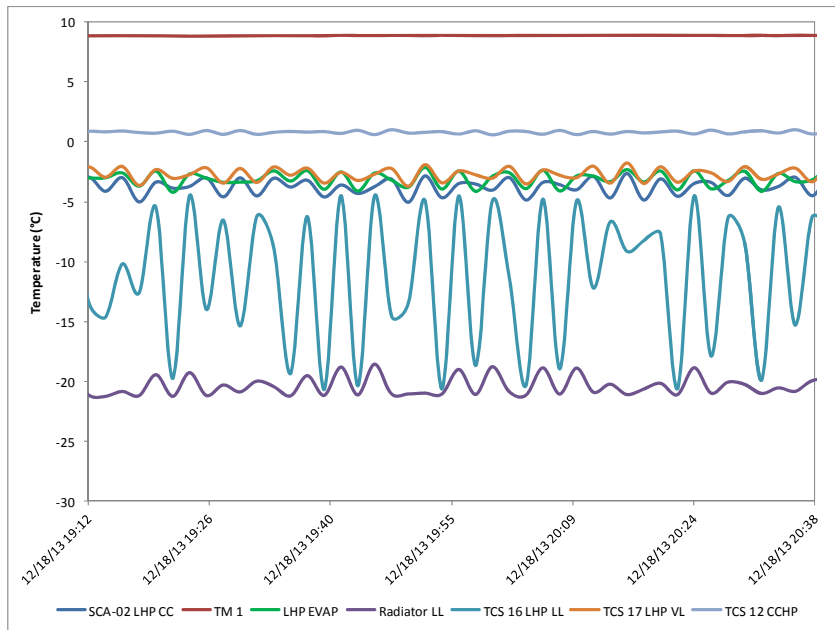

Figure 16. Oscillating Temperatures during Quasi-Steady State with 196W and -78°C Sink Temperature

Under the condition of $(Q/mC_p)_{RES} > (Q/mC_p)_{TM}$, a greater $(Q/mC_p)_{RES}$ will have a more profound effect on the flow reversal and yield a larger amplitude of the temperature oscillation as long as the reservoir control heater is continuously on. In Figure 17, the amplitude of the temperature oscillation as indicated by TCS-11 with control heaters at 22W full power was less than 2 °C for Test #4. In Figure 18, the total reservoir heater power varied between 19W and 38W. The magnitude of temperature oscillation shown by TCS-11 was close to 2.4 °C. As expected, increasing the control heater power from 22W to 19W/38W raised the reservoir temperatures from -8.5 °C/-6.5°C to -4.4°C/-2.0°C under quasi-steady state.

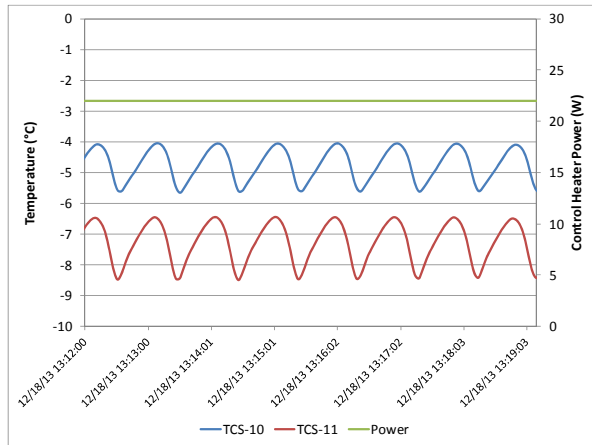

Figure 17. Temperature Oscillations with 22W Reservoir Control Heater Power

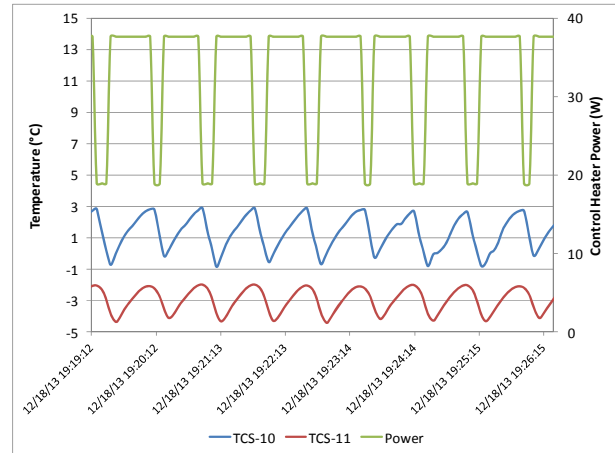

Figure 18. Temperature Oscillations with 38W/19W Reservoir Control Heater Power

3.5 Test #6: No Reservoir Control Heater Power

When the reservoir control heater power decreases so that $(Q/mC_p)_{TM} > (Q/mC_p)_{RES}$, the temperature oscillation will eventually disappear. A special case where the control heater power was completely removed is shown in Figure 19. The corresponding reservoir temperatures and control heater power with a 4-second data collection rate are shown in Figure 20. This test was a continuation of Test #5. At 12/18/13 21:10, the reservoir control heaters were turned off. The temperature oscillation quickly diminished and then completely disappeared.

After the control heaters were turned off, the reservoir temperature continued to decrease. The net heat input to the evaporator was greater than the applied 196W due to the release of sensible heat by the thermal mass during the transient. When the reservoir temperature reached -15 °C, the entire condenser/radiator was fully utilized and warm liquid

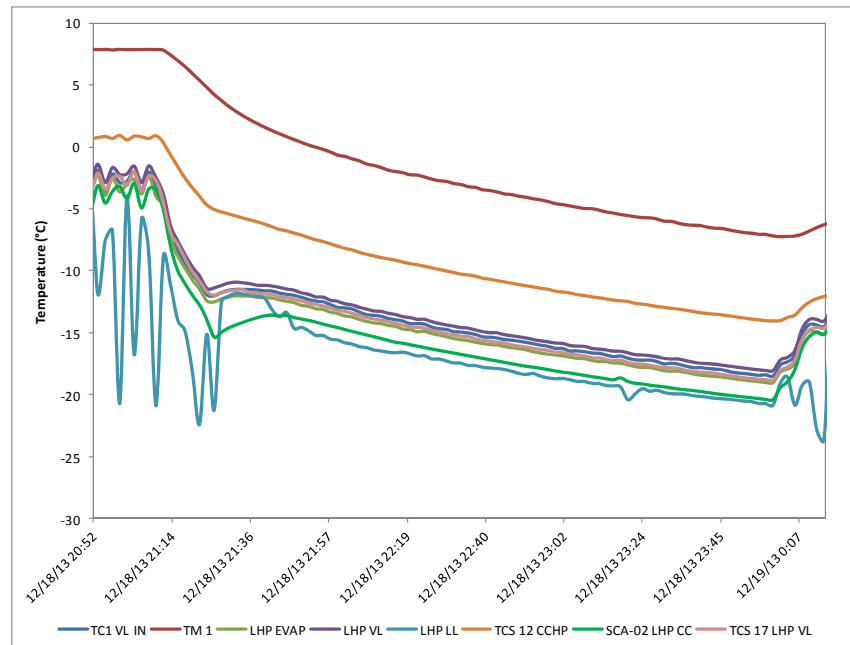

Figure 19. Loop Temperatures with and without Control Heater Power

was fed into the reservoir, raising the reservoir temperature. Full utilization of the condenser/radiator can be seen in Figure 20 where the entire radiator had a nearly uniform temperature soon after the reservoir temperature decreased to $-15\text{ }^{\circ}\text{C}$. The temperatures were those measured by the thermocouples shown in Figure 10. The condenser/radiator remained fully utilized during the period of zero control heater power. The LHP was running at its natural operating temperature. Without the control heater power to the reservoir, the driving force for a reverse liquid flow was removed, and temperature oscillation completely disappeared. When the reservoir heaters were turned on again at 12/18/13 23:55, the control heater power varied between 11W and 22W. The temperature oscillation reappeared but had smaller amplitudes compared to the temperature oscillation earlier with 19W/38W of control heater power.

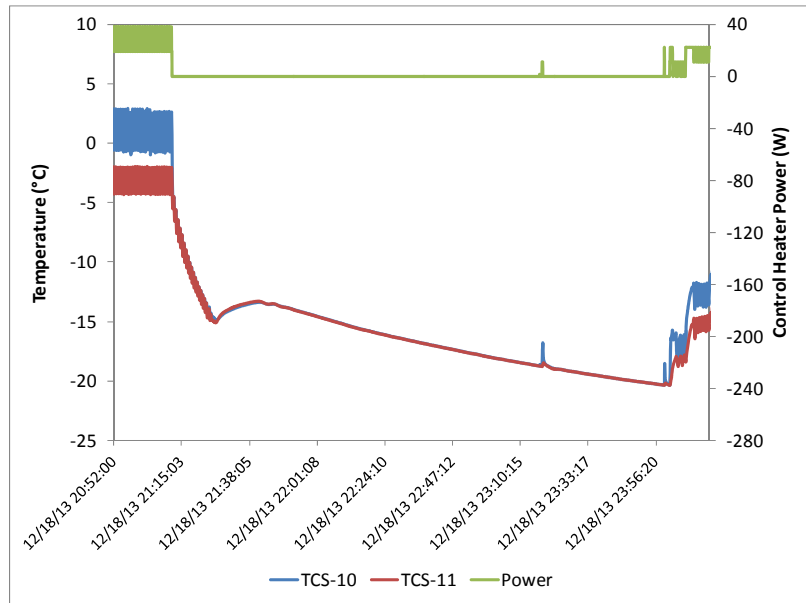

Figure 20. Reservoir Temperatures with and without Control Heater Power

3.6 Vapor Front Movement

The vapor front movement inside the condenser resulted from changes in the reservoir temperature, gravitational pressure head, heat load to the evaporator, and the reverse liquid flow. Its advance also contributed to the reservoir temperature drop. The movement of the vapor front can be tracked by examining the condenser temperatures. Unfortunately, the condenser was embedded inside the honeycomb radiator and no temperature sensors were installed directly on the condenser itself. Although some thermocouples were installed on the radiator along the condenser footprints, these sensors did not measure the true condenser temperature due to conduction and radiation effects.

Figure 22 shows temperatures of the thermocouples on the radiator following the condenser footprints for the same test and the same time period as those shown in Figure 19. The reservoir temperature oscillation with an amplitude of $2\text{ }^{\circ}\text{C}$ simply had no effect on these thermocouples.

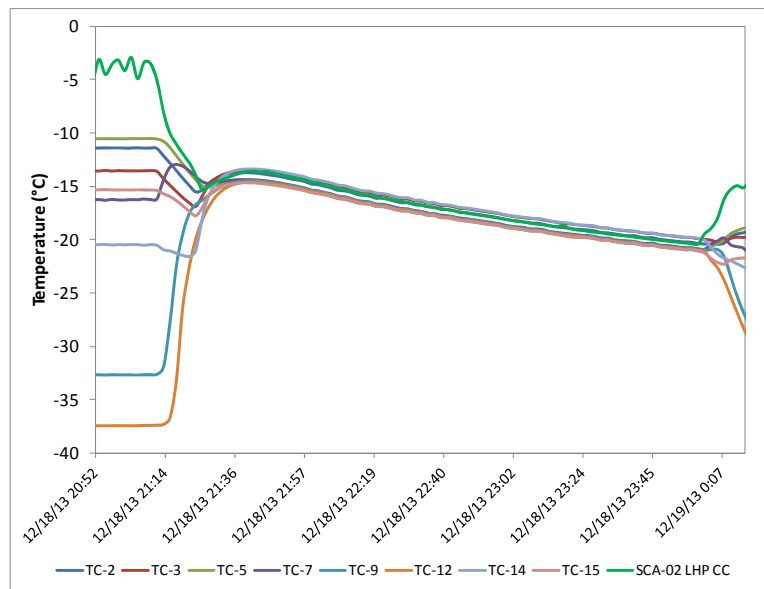

Figure 21. Radiator Temperature with and without Control Heater Power

3.7 Reservoir Quasi-Steady Temperature

Table 1 summarizes the reservoir temperature under various test conditions. In all tests which required reservoir heating, the control heaters could not keep the reservoir at its desired set point temperature. The control heaters were always turned on, and the temperature oscillation persisted. The average reservoir temperature was either increasing or decreasing towards its quasi-steady temperature. In order to save test time, only one of the tests was carried out until the reservoir temperature established a true quasi-steady state because the desired reservoir set point temperature could not be reached anyway. Nevertheless, effects of some test parameters on the reservoir temperature can still be examined.

A higher heat load to the thermal mass raised the reservoir temperature because the radiator was more utilized and the subcooling of liquid returning to the reservoir was reduced. This is seen by comparing Test #2 and Test #3. Similarly, a higher radiator sink temperature reduces the liquid subcooling and raised the reservoir temperature as can be seen by comparing Test #3 and Test #4. Test #4 and Test #5 show that a larger control heater power raised the reservoir temperature, but also increased the amplitude of the reservoir temperature oscillation. Note that a large control heater power could shut down the loop, and the loop would be operating in a perpetual start-up and shutdown mode.

In the LTCS TV tests, the heat loads to the thermal masses were 136W and 196W, while the reservoir control heater powers were 19W, 22W and 38W. The combination of the thermal mass power and reservoir control power varied from test to test, but there was no indication of a loop shutdown in any test. The most likely reason is that the heating period was not long enough for the reservoir temperature to rise above the evaporator temperature before the next half cycle of the reservoir temperature decrease.

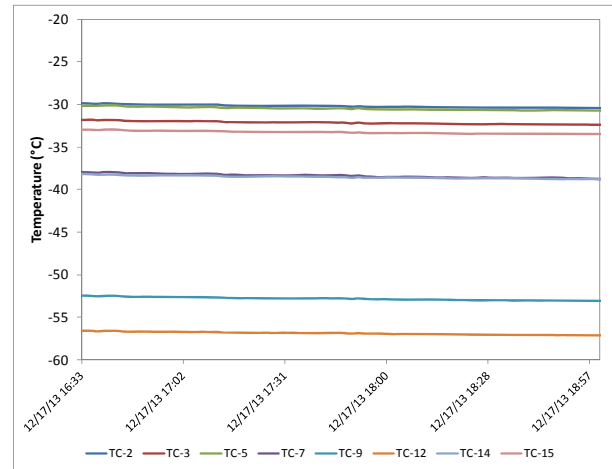

Figure 22. Radiator Temperatures during Oscillations with 38W/19W Reservoir Power

Table 2. Reservoir Temperature under Various Test Conditions

Test #	Loop Status	Thermal Mass Power (W)	Reservoir Heater Set Points (°C)	Reservoir Heater Power (W)	Chamber Shroud Temperature (°C)	Reservoir Temperature Valley/Peak (°C)
1	Transient	136	+4/+5	22	-101	decreasing
2	Quasi-steady	136	+4/+5	22	-101	-25.0/-22.9
3	Near quasi-steady	196	-2/-1	22	-101	-16.2/-14.2
4	Near quasi-steady	196	-2/-1	22	-78	-8.5/-6.5
5	Near quasi-steady	196	-2/-1	38/19	-78	-4.4/-2.0
6	Transient	196	N/A	0	-78	-20.2 (decreasing and no oscillation)

IV. Summary and Conclusions

A theory has been developed to explain the problem of an extraordinarily high reservoir control heater power requirement in the ATLAS LTCS TV testing. It was found that the root cause of the problem was fluid flow and reservoir temperature oscillations in the LHP, which led to persistent alternate forward and reversed flow along its liquid line and an imbalance of the vapor mass flow rate in the vapor line and liquid mass flow rate in the liquid line. The flow and temperature oscillations were caused by an interaction between gravity and reservoir heating, and were exacerbated by the vertical radiator/condenser which induced variable gravitational pressure head, and the large thermal mass of the instrument simulator which modulated the heat load to the evaporator through the storage

and release of its sensible heat. Furthermore, causes and effects of the contributing factors to the flow and temperature oscillations intermingled.

The theory could not be fully verified by the existing ATLAS LTCS TV test data because of the following reasons: 1) there were no temperature sensors installed directly on the condenser. Hence, the vapor front movement inside the condenser could not be tracked. 2) The TV test facilities only provided temperature data every two minutes, which was inadequate for studying the LHP transient behaviors. Nevertheless, relevant data from the test still provide partial verification of the theory.

Stopping the reservoir temperature oscillation can stop the persistent alternate forward and reverse liquid flow in the liquid line, thereby reducing the reservoir control heater power. Factors contributing to the persistent reservoir temperature oscillation are: 1) gravity assist; 2) a cold condenser/radiator; 3) a large thermal mass; 4) sufficiently large control heater power to cause a reverse liquid flow; and 5) insufficient control heater power to maintain the reservoir set point temperature.

For future instrument and spacecraft level TV testing of the ATLAS LTCS, the radiator must be placed in a vertical position. The radiator sink temperature, the laser thermal mass, and the maximum control heater power are all pre-determined and cannot be changed. Increasing the control heater power to maintain the reservoir set point runs the risk of shutting down the LHP and leave the LHP in a perpetual start and shutdown mode of operation. The most practical way to reduce the control heater power for TV testing is to reduce liquid subcooling artificially by heating the liquid line. This method was actually used in the follow-up test of the ATLAS LTCS TV testing. By applying up to 90W of heater power to the liquid line, the reservoir temperature was kept at its set point and no fluid flow or reservoir temperature oscillations were seen in all tests. The results of the follow-up test will be published in the future.

References

1. Ku, J., Robinson, F., Patel, D., and Ottenstein, L., "Thermal Performance of ATLAS Laser Thermal Control System Demonstration Unit," Paper No. AIAA-2013-2498, *44th AIAA Thermophysics Conference*, San Diego, California, June 24-27, 2013.
2. Goncharov, K., Nikitkin, M., Fershtater, Y., and Maidanik, Y., "Loop Heat Pipes in Thermal Control System for OBZOR Spacecraft," *25th International Conference on Environmental Systems*, San Diego, California, July 10-13, 1995.
3. Rodriguez, J. I., "Thermal Design of the Tropospheric Emission Spectrometer Instrument," SAE Paper No. 2000-01-2274, *30th International Conference on Environmental Systems*, Toulouse, France, July 10-13, 2000.
4. Grob, E., Baker, C., and McCarthy, T., "Geoscience Laser Altimeter System (GLAS) Loop Heat Pipe: An Eventful First Year On-Orbit", Paper No. 2004-01-2558, *34th International Conference on Environmental Systems*, Colorado Springs, Colorado, July 19-22, 2004.
5. Goncharov, K., Buz, V., Elchin, A., Prochorov, Y., and Surguchev, O., "Development of Loop Heat Pipes for Thermal Control System of Nickel-Hydrogen Batteries of 'Yamal' Satellite," *XIII International Heat Pipe Conference*, Shanghai, China, September 21-25, 2004.
6. Choi, M., "Thermal Assessment of Swift BAT Instrument Thermal Control System in Flight", Paper No. 2005-01-3037, *35th International Conference on Environmental Systems*, Rome, Italy, July 11-14, 2005.
7. Choi, M., "Thermal Assessment of Swift Instrument Module Thermal Control System during First 2.5 Years in Flight," Paper No. 2007-01-3083, *37th International Conference on Environmental Systems*, Chicago, Illinois, July 9-12, 2007.
8. Rodriguez, J. I., Na-Nakornpanom, A., Rivera, J., Mireles, V. and Tseng, H., "On-Orbit Thermal Performance of the TES Instrument – Three Years in Space," SAE Paper No. 2008-01-2118, *38th International Conference on Environmental Systems*, San Francisco, California June 30 - July 2, 2008.
9. Grob, E., "Performance of the GLAS Loop Heat Pipes – 7 Years in Orbit", Paper No. AIAA-2010-6029, *40th International Conference on Environmental Systems*, Barcelona, Spain, July 11-15, 2010.
10. Maidanik, Y. F., et al, "Thermoregulation of Loops with Capillary Pumping for Space Use," SAE Paper No. 921169, *22nd International Conference on Environmental Systems*, Seattle, Washington, July 13-16, 1992.
11. Maidanik, Y., and Fershtater, Y., "Theoretical Basis and Classification of Loop Heat Pipes and Capillary Pumped Loops," *10th International Heat Pipe Conference*, Stuttgart, Germany, 1997.
12. Ku, J., "Operating Characteristics of Loop Heat Pipes," SAE Paper No. 1999-01-2007, *29th International Conference on Environmental Systems*, Denver, Colorado, July 12-15, 1999.
13. Maidanik, Y., "Loop Heat Pipes – Theory, Experimental developments and Application," *13th International Heat Pipe Conference*, Sydney, Australia, August 9-13, 2006.
14. Ku, J., "Heat Load Sharing in a Loop Heat Pipe with Multiple Evaporators and Multiple Condensers," AIAA Paper No. AIAA-2006-3108, *9th AIAA/ASME Joint Thermophysics and Heat Transfer Conference*, San Francisco, CA, June 5-8, 2006.
15. Ku, J., Garrison, M., Patel, D., Ottenstein, L., and Robinson, F., "Temperature Oscillation in Loop Heat Pipe with Gravity Assist," *2014 Spacecraft Thermal Control Workshop*, El Segundo, California, March 25-27, 2014.