

US009067325B2

(12) **United States Patent**
Ihrke et al.(10) **Patent No.:** **US 9,067,325 B2**
(45) **Date of Patent:** **Jun. 30, 2015**(54) **HUMAN GRASP ASSIST DEVICE SOFT GOODS**(75) Inventors: **Chris A. Ihrke**, Hartland, MI (US); **Donald R. Davis**, Novi, MI (US); **Douglas Martin Linn**, White Lake, MI (US); **Bryan Bergelin**, Houston, TX (US); **Lyndon B. J. Bridgwater**, Friendswood, TX (US); **Heather Bibby**, Houston, TX (US); **Judy Schroeder**, Houston, TX (US); **Craig Erkkila**, Houston, TX (US)(73) Assignees: **GM Global Technology Operations LLC**, Detroit, MI (US); **The United States of America As Represented by the Administrator of the National Aeronautics and Space Administration**, Washington, DC (US)

(*) Notice: Subject to any disclaimer, the term of this patent is extended or adjusted under 35 U.S.C. 154(b) by 791 days.

(21) Appl. No.: **13/408,668**(22) Filed: **Feb. 29, 2012**(65) **Prior Publication Data**

US 2013/0219586 A1 Aug. 29, 2013

(51) **Int. Cl.****G06F 7/00** (2006.01)
A61H 1/00 (2006.01)
A63B 23/16 (2006.01)
B25J 15/08 (2006.01)
B25J 15/02 (2006.01)
A41D 19/015 (2006.01)
A41D 19/00 (2006.01)(52) **U.S. Cl.**CPC **B25J 15/08** (2013.01); **B25J 15/02** (2013.01);
A41D 19/01547 (2013.01); **A41D 19/01582**
(2013.01); **A41D 19/0024** (2013.01)(58) **Field of Classification Search**None
See application file for complete search history.(56) **References Cited**

U.S. PATENT DOCUMENTS

5,117,700	A	6/1992	Trechsel	
5,184,319	A	2/1993	Kramer	
5,845,540	A	12/1998	Rosheim	
5,967,580	A	10/1999	Rosheim	
6,658,962	B1	12/2003	Rosheim	
7,784,363	B2	8/2010	Ihrke et al.	
8,029,414	B2	10/2011	Ingvast et al.	
8,056,423	B2*	11/2011	Abdallah et al.	73/826
2003/0221238	A1	12/2003	Duboff et al.	
2010/0152898	A1	6/2010	Reiland et al.	
2010/0280659	A1	11/2010	Abdallah et al.	

(Continued)

FOREIGN PATENT DOCUMENTS

JP	S56156155	A	12/1981
JP	2009022577	A	2/2009

Primary Examiner — Yolanda Cumbess(74) *Attorney, Agent, or Firm* — Quinn Law Group, PLLC(57) **ABSTRACT**

A grasp assist system includes a glove and a flexible sleeve. The glove includes a digit such as a finger or thumb, a force sensor configured to measure a grasping force applied to an object by an operator wearing the glove, and adjustable phalange rings positioned with respect to the digit. A saddle is positioned with respect to the finger. A flexible tendon is looped at one end around the saddle. A conduit contains the tendon. A conduit anchor secured within a palm of the glove receives the conduit. The sleeve has pockets containing an actuator assembly connected to another end of the tendon and a controller. The controller is in communication with the force sensor, and calculates a tensile force in response to the measured grasping force. The controller commands the tensile force from the actuator assembly to tension the tendon and thereby move the finger.

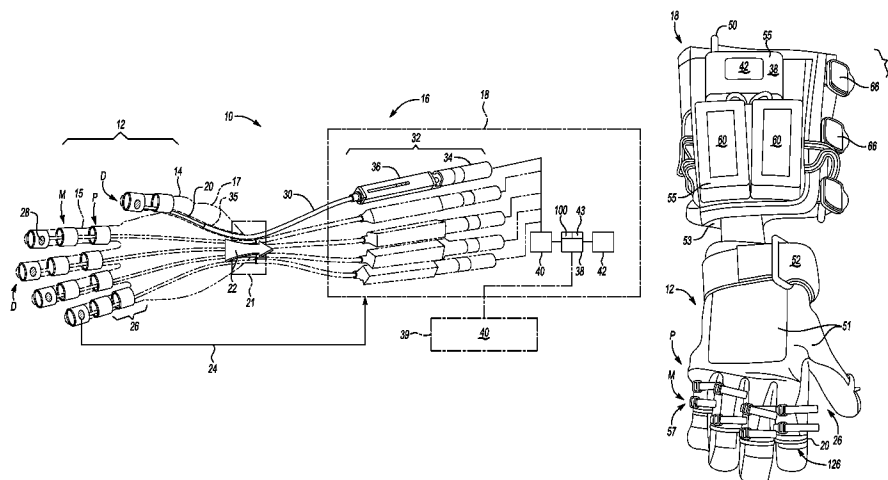
17 Claims, 3 Drawing Sheets

(56)

References Cited

U.S. PATENT DOCUMENTS

2010/0280662 A1 11/2010 Abdallah et al.

2011/0071664 A1* 3/2011 Linn et al. 700/213
2011/0071678 A1 3/2011 Ihrke et al.

* cited by examiner

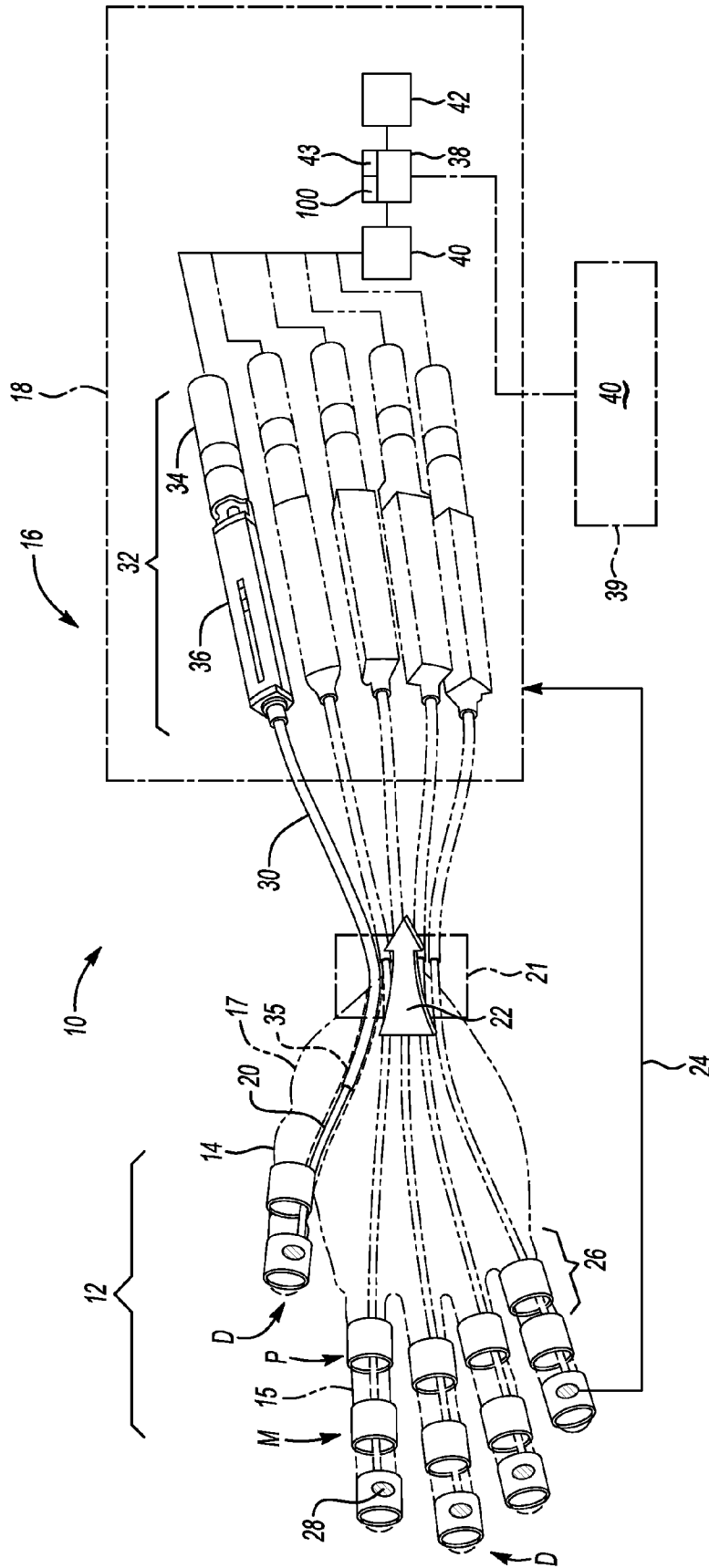

Fig-1

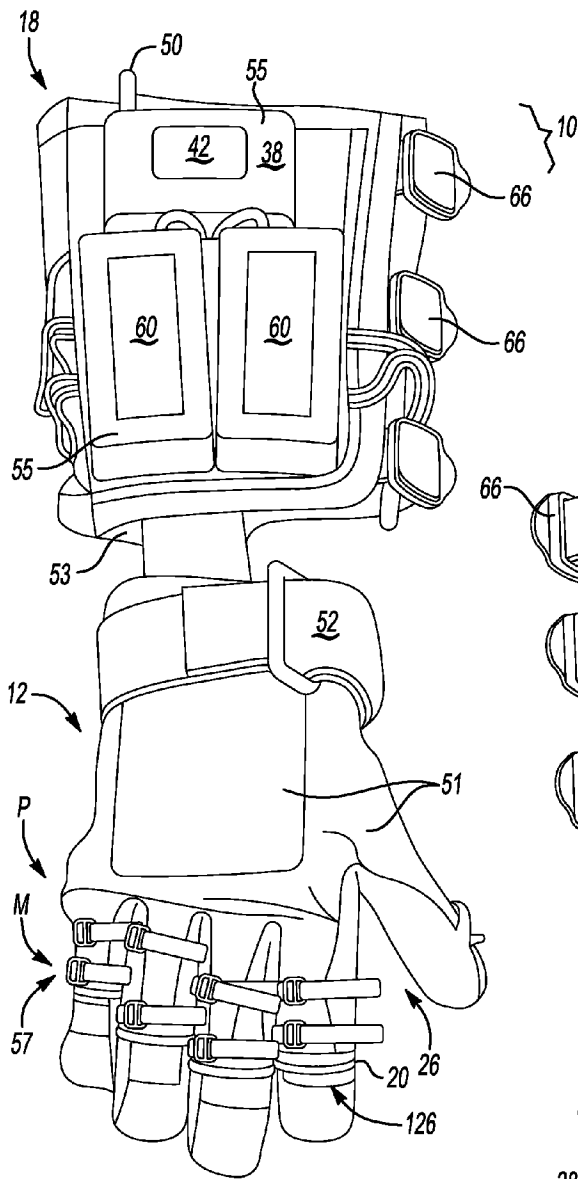

Fig-2

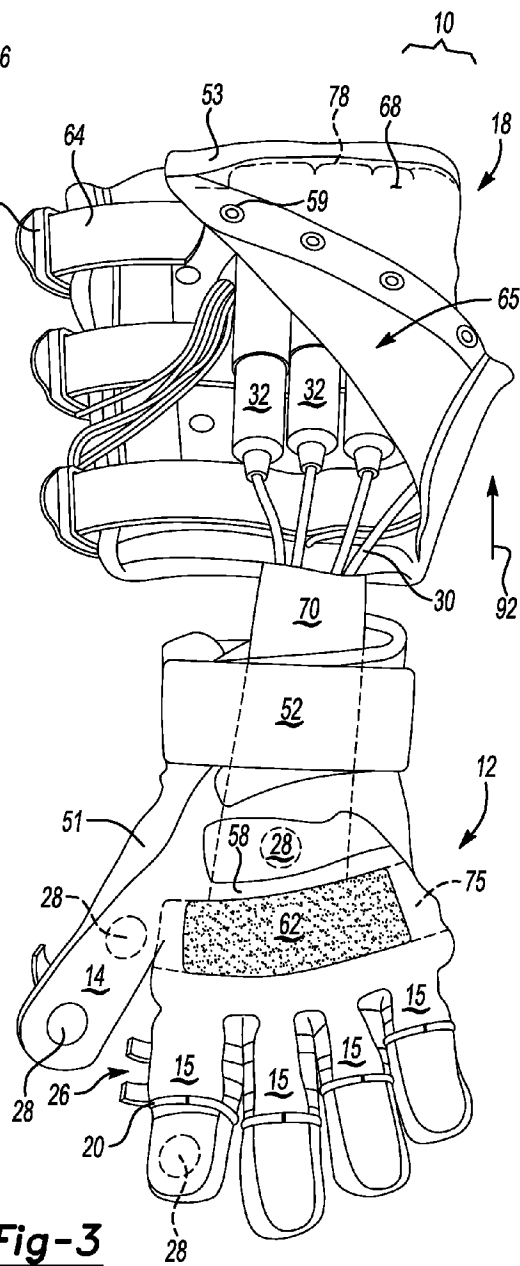

Fig-3

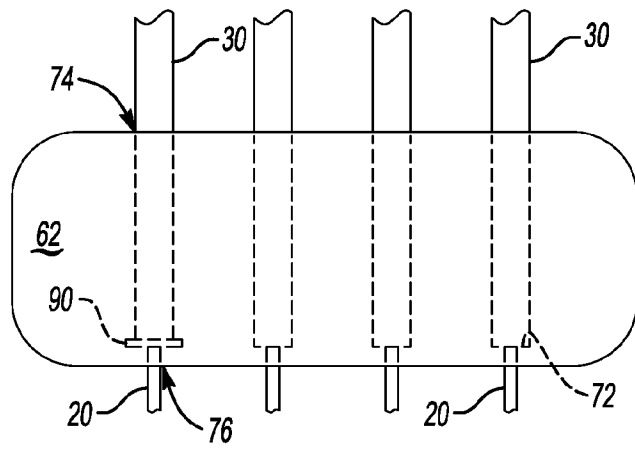

Fig-4

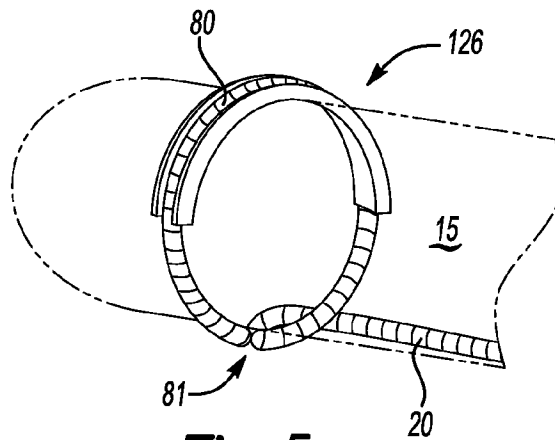

Fig-5

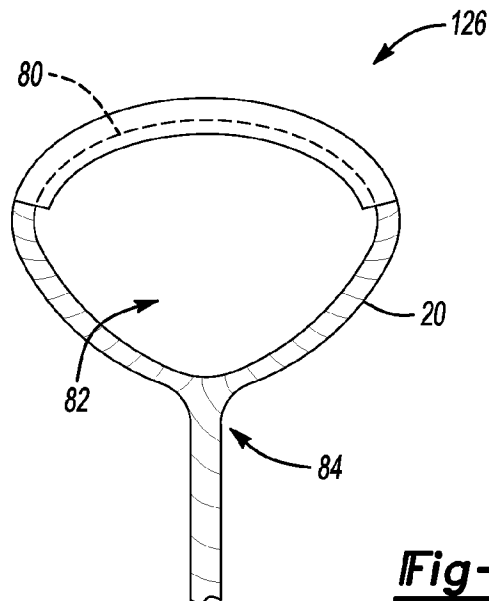

Fig-6

1

HUMAN GRASP ASSIST DEVICE SOFT GOODS

STATEMENT REGARDING FEDERALLY SPONSORED RESEARCH OR DEVELOPMENT

This invention was made with government support under NASA Space Act Agreement number SAA-AT-07-003. The invention described herein may be manufactured and used by or for the U.S. Government for U.S. Government (i.e., non-commercial) purposes without the payment of royalties thereon or therefor.

TECHNICAL FIELD

The present disclosure relates to soft goods/packaging of a human grasp assist device.

BACKGROUND

Ergonomics is an evolving scientific discipline that ultimately seeks to understand and improve human interactions with the various pieces of equipment used within a work environment, e.g., keyboards, workstations, torque wrenches, control input devices, and the like. Good ergonomic design practices seek to optimize aspects of the physical work environment as they relate to the human operators working therein. However, certain work tasks may stress an operator in a manner that cannot be lessened by even the most optimal of ergonomic workplace configurations.

For example, manual operations requiring a repetitive or sustained grasping of an object can stress an operator's hands, fingers, and forearms. As a result, an operator's grasp strength and productivity can gradually decline over the course of a work day. Grasp strength can also vary widely between different operators due to differences in physical stature, injury, and/or muscle fatigue. The variable nature of a given operator's grasp strength may result in relatively inefficient execution of certain grasp-related work tasks. Conventional devices such as wrist straps and braces exist for easing some of the stress on an operator. However, such devices may remain less than optimal for improving overall grasp strength.

SUMMARY

A grasp assist device is disclosed herein that a human operator may use for increased grasp strength and/or rehabilitation. The comfort and functionality of such a device may be improved using the packaging or soft goods set forth herein. The present device includes a glove that is worn on the operator's hand and a sleeve that is worn on the operator's forearm. The device may include one or more flexible tendons that are selectively tensioned with a calculated tensile force by a corresponding actuator assembly. The actuator assembly pulls as needed on the tendon(s) to help close one or more digits of the glove, and thus of the operator's hand contained therein, into a desired grasp pose. In an alternative embodiment the tendon(s) may be routed so as to help open the operator's hand when releasing the grasp pose, i.e., grasp release assistance. Force sensors positioned with respect to the glove provide force feedback signals to a controller contained in the sleeve. The controller commands the calculated tensile force to thereby place one or more of the tendons under tension.

In particular, a grasp assist device in one embodiment includes a glove having a digit, i.e., a finger or a thumb, and a force sensor positioned with respect to the glove. The force

2

sensor measures a grasping force applied to an object by an operator wearing the glove. The glove includes adjustable phalange rings and a saddle positioned with respect to the digit, a flexible tendon having one end connected to the saddle, and a conduit containing the tendon. The glove also includes a conduit anchor positioned on or within the glove. The conduit anchor receives the conduit and prevents undesired axial motion of the conduit toward the fingers when the tendon is under tension.

The grasp assist device in this embodiment also includes a flexible sleeve. The sleeve has pockets containing an actuator assembly and a controller. The actuator assembly is connected to another end of the tendon. The controller, which is communication with the force sensor and the actuator assembly, calculates a tensile force to apply to the tendon in response to the measured grasping force, and then commands the calculated tensile force from the actuator assembly.

In other embodiments, a thumb and/or multiple fingers may be moved via the tendons. The force sensor may be positioned with respect to the palm of the glove or any of the fingers/thumb. Reinforcement of the conduit anchor may be provided via one or more inelastic or non-stretchable straps, whether extending between the glove and the sleeve or wrapping around the glove near the palm. The saddle may be arcuate, and may define an arcuate groove which receives the tendon such as by looping the tendon around the saddle and seating the tendon in the groove. The tendon may be spliced to itself adjacent to the saddle to form a loop through which a digit of the glove is inserted. An optional tension sensor may be positioned with respect to the conduit, for instance in the conduit anchor adjacent to the conduit, and configured to measure an actual tensile force acting on the conduit, e.g., in a rehabilitation mode.

The above features and advantages and other features and advantages of the present invention are readily apparent from the following detailed description of the best modes for carrying out the invention when taken in connection with the accompanying drawings.

BRIEF DESCRIPTION OF THE DRAWINGS

FIG. 1 is a schematic illustration of an example grasp assist device having a glove, a sleeve, and a controller.

FIG. 2 is a schematic top view illustration of the example grasp assist device shown in FIG. 1.

FIG. 3 is schematic bottom view illustration of the example grasp assist device shown in FIGS. 1 and 2.

FIG. 4 is a schematic plan view illustration of an example conduit anchor usable with the glove of FIGS. 2 and 3.

FIG. 5 is a schematic perspective view illustration of an example saddle usable with the glove of FIGS. 2 and 3.

FIG. 6 is a schematic side view illustration of the example saddle of FIG. 5 with a tendon seated therein.

DETAILED DESCRIPTION

With reference to the drawings, wherein like reference numbers refer to the same or similar components throughout the several views, an example grasp assist system 10 is shown in FIG. 1. The grasp assist device 10 includes a glove 12 and a flexible sleeve 18. When worn by an operator, the grasp assist system 10 assists the operator in grasping an object. The grasp assist device 10 includes various soft goods as explained herein with reference to FIGS. 2 and 3, i.e., natural or synthetic materials that improve the fit, comfort, and performance of the grasp assist device 10.

The electro-mechanical operational components or hard goods of the grasp assist device **10** shown in FIG. **1** may include a set of actuators, for instance a tendon drive system (TDS) **16** in one possible embodiment. The TDS **16** may be fully enclosed or contained at least partially within the sleeve **18**. The TDS **16** may be linked to the glove **12** via one or more flexible tendons **20**, for example braided polymers, with an augmenting tensile force (arrow **22**). The tensile force (arrow **22**) is calculated by a controller **38** in response to force feedback signals **24** from one or more force sensors **28** positioned with respect to the glove **12**, e.g., on fingers **15** and/or a thumb **14** thereof, or on a palm **58** of the glove **12** as shown in FIG. **3**. The calculated tensile force (arrow **22**) is then applied to some or all of the tendons **20** by the TDS **16**.

The glove **12** may include one or more digits, for instance the thumb **14** and one or more fingers **15**. A full four-finger/one thumb glove may be used as shown, or a glove **12** may be envisioned having fewer fingers **15** or no thumb **14** in other embodiments. The intended grasp pose would determine the particular design of the glove **12**. For example, a grasp pose in which a small object is pinched by an operator may only require a glove **12** having a thumb **14** and one finger **15**, e.g., an index finger, while a full-handed grasp of an object may require a four-fingered glove with a thumb **14**.

An operator may wear the glove **12** in the manner of a conventional glove. The phalange rings **26** of FIG. **1** are shown schematically. As described below with respect to FIGS. **2** and **3**, some of these phalange rings **26** may be flexible and adjustable. Others may form non-adjustable saddles **126** as described below with reference to FIGS. **5** and **6**.

When the glove **12** of FIG. **1** is worn on an operator's hand, each of the phalange rings **26** may at least partially circumscribe a respective one of the thumb **14** and fingers **15** of the glove **12**, and thus the operator's own thumb and fingers, or the rings **26** may be positioned within the material **17** defining the thumb **14**/fingers **15** depending on the embodiment. Thus, any tensile force (arrow **22**) applied to some or all of the tendons **20** routed through the phalange rings **26** of the glove **12** can indirectly act on an operator's fingers/thumb through a reaction force with respect to the phalange rings **26**.

In general, a threshold grasping force exerted by an operator on an object held in the operator's grasp activates any of the force sensor(s) **28** that are in contact with the object. The phalange rings **26** are connected to or in contact with the tendons **20** that run through the phalange rings **26**, with at least some of the phalange rings **26** thus acting as guides for the tendons **20**. The phalange rings **26** may be distal (arrow **D**), i.e., positioned at the distal end of a finger **15** or thumb **14**, medial (arrow **M**), i.e., positioned at the medial joint of the finger **15** or thumb **14**, or proximal (arrow **P**, i.e., positioned at the proximal joint of the finger **15** or thumb **14**. Each of the tendons **20** terminates at a phalange ring **26**, such as the distal (arrow **D**) phalange rings **26** as shown in FIG. **1**, or a medial phalange ring **26** as shown in FIGS. **2** and **3**. Where the tendons **20** terminate, a saddle **126** (see FIGS. **2**, **5**, and **6**) may be used to loop the tendon **20** back onto itself into position for rope splicing or other connection as described below.

The TDS **16** of FIG. **1** is connected to one end of a corresponding one of the tendons **20**. Each tendon **20** is disposed and freely moveable within a conduit **30**. The conduit **30** may be substantially rigid in the compressive direction and flexible in other directions, e.g., a stainless steel coil. In one embodiment, each of the tendons **20** may be configured as a braided polymer, which in turn may include a suitable fluorocarbon that increases the wear life of each tendon. How-

ever, other materials may also be used without departing from the intended scope of the invention.

The tendons **20** may pass through an optional tendon concentrator **21**, which is shown schematically in FIG. **1**. The tendon concentrator **21** may be located on or near the base of the palm or a wrist area of the operator. As shown in phantom, multiple actuator assemblies **32**, for instance motorized ball screw devices or linear actuators to which the tendons **20** are attached, may be configured in an array within the TDS **16**. Each actuator assembly **32** acts on a corresponding tendon **20**. When only one TDS **16** is used, the tendon concentrator **21** may be used to connect the tendons **20** leading from a thumb **14** and each finger **15** to a single actuator tendon, i.e., the tendon **20** shown via solid lines in FIG. **1**. The tendon concentrator **21** in this instance provides an area for the multiple tendons **20** to be connected to a single tendon **20**.

Still referring to FIG. **1**, the actuator assembly **32** according to a particular embodiment may include a servo motor **34** and a drive assembly **36**, for example a ball and screw-type device according to one embodiment. Other embodiments are possible, e.g., linear actuators, motorized spools, etc. Operational control of the TDS **16** is provided via the controller **38**. The controller **28** may draw any required power from an energy supply **40**. The energy supply **40** may be part of an integrated electronics package **60** as shown in FIG. **2** and described below, or it may be a larger unit worn external to the sleeve **12**, such as on an optional belt pack **39**. Use of the belt pack **39** may enable a larger energy supply **40**. The energy supply **40** may be configured as a battery pack, for instance a lithium ion cell or cells, or any other relatively lightweight or low-mass energy storage device.

A user interface **42** may be connected to the sleeve **18** in signals communication with the controller **38**, or it may be an integral part of the controller **38**. The user interface **42** may be used to facilitate selection of a desired operating mode, and therefore may be configured as an operator-accessible control panel, a touchpad, or a touch screen allowing an operator to interface with the controller **38**. The controller **38** of FIG. **1** processes the set of feedback signals (arrow **24**). Computer-executable code **100** may be recorded on tangible, non-transitory memory **43** of the controller **38** and executed thereby to calculate and select an optimal augmenting tensile force (arrow **22**) in response to the values relayed via the feedback signals (arrow **24**) and the user-selected operating mode, as well as to provide other control actions as set forth below with reference to FIG. **3**. This augmenting tensile force (arrow **22**) is then applied to some or all of the tendons **20** using the drive assembly **36** to assist the grasp of an operator wearing the grasp assist device **10**.

The controller **38** of FIG. **1** may include one or more integrated circuits, which may be augmented by various electronic devices such as voltage regulators, capacitors, drivers, timing crystals, communication ports, etc. The controller **38** may be a microcontroller using limited power and limited read only memory (ROM), random access memory (RAM), and/or electrically-programmable read only memory (EPROM), and any required input/output (I/O) circuit devices, as well as signal conditioning and buffer electronics. A central processing unit is used to provide the required processing power. Individual control algorithms resident in the controller **38** or readily accessible thereby may be stored in, e.g., ROM, and automatically executed at one or more different control levels to provide the respective control functionality.

Referring to FIGS. **2** and **3**, the soft goods portions of the upper surfaces (FIG. **2**) and lower surfaces (FIG. **3**) of the grasp assist device **10** of FIG. **1** are shown in further detail.

The structural elements described hereinafter are configured to package and support the controller **38**, the TDS **16**, and the force sensor(s) **28** of FIG. **1** in a comfortable manner, i.e., the hard goods or electromechanical operating components of the grasp assist device **10**. As the grasp assist device **10** may be worn by an operator for an extended period of time, treatment of heat and moisture are principle design concerns, as are reduced weight, tactile comfort, and ease of wear.

Any portions of the grasp assist **10** which directly contact the human operator while in use may be constructed of a suitable synthetic, breathable fiber such as elastane or perforated Lycra®. With reference to FIG. **2**, such surfaces may include the backside **51** of the glove **12** as well as internal surfaces **53** of the sleeve **18**. The sleeve **18** may also include pockets **55**, which may be constructed at least partially out of neoprene or nylon mesh in possible embodiments.

The pockets **55** may contain the controller **38**, the user interface **42**, and the associated integrated electronics package **60**, for example wiring, power conditioning components, and drivers for safely and reliably powering the grasp assist device **10**. If a remote user interface **42** is used such as a tablet computer, a human machine interface, or another suitable input device, the user interface **42** shown in FIG. **2** may include a display screen presenting the particular control option selected via the remote device.

The controller **38**, user interface **42**, and integrated electronics package **60** may be sewn or otherwise secured in place via the pockets **55**. A wireless interface **50** for the controller **38** may extend from the top of the sleeve **18** as shown when wireless connectivity is included as part of the controller **38**. The wireless interface **50** may be used to communicate with remote devices such as a database management system for tracking use and performance of the device **10**. Buckles **66** may be used to secure the sleeve **18** to an operator's forearm, thus allowing the grasp assist device **10** to be adjusted as needed to fit multiple different operators.

The glove **12** of FIG. **2** may also include an adjustable wrist strap **52**, e.g., nylon and Velcro® or other suitable material. The wrist strap **52** serves two main functions. The first function is securing of the glove **12** to the operator's hand. The second function of the wrist strap **52** is reinforcement of the conduit anchor **62** of FIG. **3** and added restraint against undesired axial motion of the conduits **30** shown in FIGS. **1**, **3**, and **4** as discussed below.

Also shown in FIG. **2** are the phalange rings **26**. Some of the phalange rings **26** may be adjustable. Any phalange rings **26** that are adjustable, e.g., the proximal (arrow P) and medial (arrow M) phalange rings **26** in the example embodiments shown in FIGS. **2** and **3**, may be constructed of nylon or another suitable rugged and flexible material. The phalange rings **26** keep the tendons **20** routed in close proximity to the operator's finger/thumb in the glove **12**, and also transmit the tensile force (arrow **22** of FIG. **1**) to the backs of the proximal (arrow P) and medial (arrow M) phalanges of the glove **12**. Adjustment of the phalange rings **26** may be provided via an adjustment feature **57**, such as a tab and loop or a belt buckle-like configuration as shown, to allow operators to customize the fit with respect to the operator's fingers/thumb.

The medial phalange (arrow M) may be used to secure the tendon **20** via a saddle **126**, whereon an end of one of the tendons **20** is connected or routed with respect to the saddle **126**. An example saddle **126** is described below with reference to FIGS. **5** and **6**. The distal phalange (arrow D of FIG. **1**) could be used to terminate the tendon **20** in other embodiments.

The saddle **126** used to terminate a given tendon **20** may form complete rings as shown in FIG. **1**, or may be an incom-

plete circle or arcuate as shown in FIG. **6**. The saddles **126** may be constructed from a suitable rigid material, for instance aluminum or hard plastic. In other embodiments, the saddles **126** may be constructed of a softer material such as an elastomer, or a combination of aluminum and elastomer, which may provide for added comfort without sacrificing strength. The saddles **126** may be seated on the outside of the glove **12** on rings or pads of leather or any other suitable material.

Referring to FIG. **3**, the grasp assist device **10** is shown from a bottom or palm-side view. The palm **58** of the glove **12** may be formed from a suitably rugged and wear-resistant material such as leather or suede. A conduit anchor **62** such as a shaped hard plastic or metal plate may be sewn or otherwise connected to the glove **12**, for example inside of the palm **58** when grasp assistance is used. When assistance is provided only upon release of a grasp, the anchor **62** may be placed on the back of the glove **12**. The conduit anchor **62** should be strong enough to prevent the conduits **30**, which should be rigid in the axial/compressive direction with respect to an axis of the conduits **30**, from pushing through the conduit anchor **62** and toward the ends of the fingers **15** when the tendons **20** (see FIG. **1**) are under tension. In other words, the conduit anchor **62** may be sufficiently rigid in the axial direction of the conduits **30**, but not necessarily rigid in other directions. For instance, some bending of the conduit anchor **62** in the direction of a cupping of the operator's palm may improve the operator's comfort, and may feel more natural to the operator in executing a given grasp pose.

In one possible embodiment, the conduits **30** may extend as far as the crease in the operator's palm, i.e., the point where the joints of the proximal (P) phalanges bend. The conduit anchor **62** in such an embodiment should be placed at the same location, which is the position shown in the example embodiment of FIG. **3**. To secure the conduit anchor **62** in place with respect to the glove **12**, a strap **70** may be used that is constructed of a substantially inelastic or non-stretchable material, e.g., nylon or canvass. The strap **70** may extend from the sleeve **12** to the conduit anchor **62**, and maybe connected to the conduits **30**. The adjustable wrist strap **52** may circumscribe the strap **70** and reinforce the strap **70** when the adjustable wrist strap **52** is tightened.

The strap **70** may be stitched, riveted, or otherwise firmly secured to the material **17** (see FIG. **1**) of the glove **12**, such that the strap **70** resists motion of the conduits **30** toward the fingers **15** when the tendon **20** is tensioned. The conduit anchor **62** may also be secured laterally with respect to the glove using another strap **75** which wraps at least partially around the glove **12** inside of the glove **12**. The additional non strap **75**, like the strap **70**, may be inelastic, and may be securely attached to the glove **12** via stitches, rivets, or other suitable means.

The sleeve **18** of FIG. **3** may include one or more forearm straps **64**. The forearm straps **64** may be tightened and buckled via the buckles **66**, and/or using Velcro closures, so as to secure the sleeve **18** to a forearm of an operator. Likewise, the glove **12** may include the wrist strap **52** noted above with reference to FIG. **2**. Tightening of the wrist strap **52** firmly secures the strap **70** with respect to an operator's wrist. In this manner, the conduit anchor **62** is prevented from moving in response to motion of the conduits **30**.

The sleeve **18** may also include a protective flap **68**. To protect the actuator assemblies **32** of the sleeve **18**, the protective flap **68** may be folded over the actuator assemblies **32** in the direction of arrow **65** and secured via fasteners **59**, e.g., snaps, Velcro®, zippers, etc. Motion of the actuator assemblies **32** in response to motion of the conduits **30** may cause the actuator assemblies **32** to move away from the glove **12** in

the direction of arrow **92**. To restrain this motion, reinforced pockets **78** may be provided in the sleeve **12** beneath the flap **68**. The actuator assemblies **32** may be seated within the reinforced pockets **78**. Thus, any motion of the actuator assemblies **32** in the direction of arrow **92** may be restrained by the reinforced pockets **78**.

The force sensor(s) **28** may be positioned on the palm side of the glove **12** as shown, e.g., on a distal end, medial portion of the thumb **14**, or on the palm **58** as shown in FIG. **3**, or alternatively one or more of the fingers **15**. Thus, when an object is grasped in a hand of an operator wearing the glove **12**, with sufficient pressure applied to the force sensor(s) **28**, the controller **38** can activate the glove **12** as explained above with reference to FIG. **1**.

Referring to FIG. **4**, an example embodiment of the conduit anchor **62** is shown for four conduits **30**. Fewer conduits **30** may be used without departing from the intended inventive scope. The conduit anchor **62** may define bores or through channels each having a first opening **74** and a second opening **76**. The first opening **74** should be slightly larger than the outside diameter of the conduit **30** to allow a snug fit without impinging the conduit **30**. Likewise, the second opening **76** is slightly larger than the outside diameter of the tendon **20**. The anchor **62** may be a solid piece of plastic, for example, with a bore defining first openings **74** formed from one end of the anchor **62**, and a bore defining the second opening **76** formed from another end of the anchor **62** coaxially with the first bore.

The conduits **30**, which as noted above are rigid in the compressive or axial direction, contact an internal surface **72** of the conduit anchor **62**, thereby bottoming out on the surface **72**. Proper restraint of the conduit anchor **62** as explained above with respect to the straps **70**, **75** of FIG. **3** thus allows undesired motion of the conduits **30** to be arrested at the conduit anchor **62**.

In a particular embodiment, the glove **12** of FIGS. **1-3** may be used for rehabilitation, such as when an operator has suffered an injury which has weakened the operator's grasp strength. Augmentation of the grasp strength may be provided as set forth above. However, it may be desirable to monitor the operator's grasp strength and track changes in the grasp strength as the operator undergoes therapy. The construction of the conduit anchor **62** is conducive to this.

A tendon tension sensor **90** of the type known in the art may be positioned with respect to a conduit **30** at the interface between the conduit **30** and the surface **72**. The sensor **90** is shown schematically in FIG. **4**, and may include structure which circumscribes the conduit **30**. The sensor **90** may include, for example, strain gauges which measure a conduit compressive force acting on the sensor **90** whenever the tendon **20** is under tension. The sensor **90** can then communicate the measured strain to the controller **38**, e.g., wirelessly via the wireless interface **50** shown in FIGS. **2** and **3**.

Measurements taken by the sensor **90** may be translated into actual tensile force measurements by the controller **38**. In turn, these tensile force measurements may be recorded and tracked by the controller **38** to evaluate progress of an operator's changing grasp strength, with or without augmentation via the actuator assemblies **32**. A different sensor **90** could be used with each conduit **30** to precisely track progress of an operator's grasp strength with respect to each of the operator's fingers **15** and thumb **14**.

As an illustrative example, an injured operator may grasp an object while wearing the grasp assist device **10** of FIGS. **2** and **3**. The force sensor(s) **28** may be initially deactivated. The configuration of FIGS. **2** and **3** enabled grasp assist. However, one of ordinary skill in the art will appreciate that by simply

reversing the position of the actuator assemblies **32**/tendons **20** one can assist the release from a grasp rather than the grasp itself. That is, the tendons **20** could be routed to act on the back of the fingers **15** of FIG. **3** so as to release the grasp rather than the palm-side of the fingers **15** to form the grasp. In such an embodiment, the tensile force of an operator forming the grasp can be measured by the sensor **90** of FIG. **4**. Over time, the operator's grasp or release strength, depending on the embodiment, can be measured and tracked to determine rehabilitation progress.

Referring to FIGS. **5** and **6**, an example saddle **126** for securing the tendon **20** to a desired portion of the finger **15** or thumb **14** of the glove **12** may define an arcuate groove **80** that is sized and shaped to receive a tendon **20**. For instance, the tendon **20** emerges from a digit of the glove **12** at location **81** of FIG. **5** and wraps around the saddle **126** as shown in FIGS. **2**, **5**, and **6**. The saddle **126** may be detached from the glove **12**, in which case the saddle **126** rests on the glove **12**, or the saddle **126** may be attached to the glove **12** via stitching or other means. As best shown in FIG. **6**, the tendon **20** forms a loop **82** around the saddle **126** such that the tendon **20** is received by/seated in the groove **80**.

After wrapping around the saddle **126** the tendon **20** wraps back onto and attaches to itself to form a splice **84**. Various rope splicing techniques exist for forming the splice **84**. For instance, the tendon **20** may be interwoven with itself at the location of the splice **84**. Tension on the tendon **20** acts over time to tighten this interweave, thus strengthening the splice **84** over time as is understood in the art. Other splicing or knotting techniques may be used to secure the tendon **20** to the saddle **126** without departing from the intended inventive scope. Additionally, the saddle **126** may form a complete ring shape (see the rings **26** of FIG. **1**) rather than the arcuate shape of FIG. **6**. In such an embodiment, the groove **80** of FIGS. **5** and **6** may still be used, or the tendon **20** may be knotted, spliced, or otherwise connected to the saddle **126** rather than looped around the saddle **126** as shown in FIG. **6**.

While the best modes for carrying out the invention have been described in detail, those familiar with the art to which this invention relates will recognize various alternative designs and embodiments for practicing the invention within the scope of the appended claims.

The invention claimed is:

1. A grasp assist system comprising:

a glove having:

- a digit selected from the group consisting of a finger and a thumb;
- a force sensor positioned with respect to the glove that is configured to measure a grasping force applied to an object by an operator wearing the glove;
- a plurality of adjustable phalange rings positioned with respect to the digit;
- a saddle positioned with respect to the digit;
- a flexible tendon that is looped at one end around the saddle;
- a conduit that at least partially contains the tendon; and
- a conduit anchor secured to the glove, wherein the conduit is received within the conduit anchor and prevented from moving in an axial or compressive direction by the conduit anchor; and

a flexible sleeve having pockets containing:

- an actuator assembly connected to another end of the tendon; and
- a controller in communication with the force sensor, wherein the controller is configured to calculate a tensile force in response to the measured grasping

- force, and to command the tensile force from the actuator assembly to thereby tension the tendon and thereby move the digit.
2. The system of claim 1, wherein the adjustable phalange rings are constructed of nylon.
3. The system of claim 1, wherein the conduit anchor defines a first opening which receives the conduit and a second opening through which the tendon passes.
4. The system of claim 1, wherein the saddle is arcuate and defines a groove in which the tendon is seated.
5. The system of claim 1, wherein the sleeve includes a reinforced pocket in which the actuator assembly is seated.
6. The system of claim 1, wherein the glove is constructed at least partially of elastane fiber.
7. The system of claim 1, wherein the flexible sleeve includes a flap which covers the actuator assembly.
8. The system of claim 1, wherein the controller includes a user interface positioned in one of the pockets of the flexible sleeve.
9. The system of claim 1, wherein the glove further includes an adjustable wrist strap.
10. The system of claim 9, further comprising an additional strap that is inelastic, and that extends between the conduit anchor and the sleeve, wherein:
 the additional strap is connected to the conduit; and
 the adjustable wrist strap circumscribes the additional strap and reinforces the additional strap when the adjustable wrist strap is tightened.
11. The system of claim 1, wherein the conduit is rigid in the compressive direction.
12. The system of claim 1, further comprising a tendon tension sensor positioned with respect to at least one of the conduits at an interface between the conduit and an internal surface of the conduit anchor, wherein the tendon tension sensor measures an actual tensile force acting on the at least one conduit and transmits the measured actual tensile force to the controller.
13. A grasp assist system comprising:
 a glove constructed at least partially of elastane fiber, and having:
 a plurality of fingers;
 a thumb;
 a force sensor positioned with respect to the thumb, wherein the force sensor is configured to measure a grasping force applied to an object by an operator wearing the glove;
 an adjustable wrist strap;
 a plurality of adjustable phalange rings, wherein a different pair of the adjustable phalange rings is posi-

- tioned with respect to the proximal and medial phalanges of a corresponding one of the fingers;
 a plurality of arcuate saddles, wherein a different one of the saddles is positioned at one of the medial and the distal phalanges of the corresponding fingers;
 flexible tendons each having a first end connected to a corresponding one of the saddles;
 a plurality of conduits, wherein each of the conduits contains a corresponding one of the tendons; and
 a conduit anchor attached to the glove, wherein the conduit plastic anchor receives the conduits therein via a first set of openings and allows the tendons to pass through the conduit anchor via another set of openings; and
 a flexible sleeve that is wearable on a forearm of the operator, wherein the sleeve includes:
 a plurality of motorized actuator assemblies, wherein each of the assemblies is connected to a second end of a corresponding one of the flexible tendons and is contained in a pocket of the sleeve; and
 a controller in communication with the force sensor, wherein the controller is configured to calculate a tensile force in response to the measured grasping force, and to command the tensile force from at least one of the actuator assemblies.
14. The system of claim 13, wherein the controller includes a user interface which is positioned in one of the pockets of the flexible sleeve.
15. The system of claim 13, wherein each of the saddles defines an arcuate groove in which a corresponding one of the tendons is seated, and wherein each of the saddles rests on a corresponding one of the fingers.
16. The system of claim 13, further comprising a tendon tension sensor positioned with respect to at least one of the conduits at an interface between the at least one conduit and an internal surface of the conduit anchor, wherein the tendon tension sensor is configured to measure an actual tensile force of a tendon and communicate the measured actual tensile force to the controller.
17. The system of claim 13, further comprising an inelastic strap extending between the conduit anchor and the sleeve, wherein:
 the inelastic strap is connected to the conduit; and
 the adjustable wrist circumscribes the inelastic strap and reinforces the inelastic strap when the adjustable wrist strap is tightened.

* * * * *