



AIAA-2003-6866

**A Combustion Research Facility for Testing
Advanced Materials for Space Applications**

Michael J. Bur

NASA Glenn Research Center

Cleveland, OH

**41st AIAA Aerospace Sciences
Meeting and Exhibit**

January 6-9, 2003 / Reno, NV

A Combustion Research Facility for Testing Advanced Materials for Space Applications

Michael J. Bur
National Aeronautics and Space Administration
Glenn Research Center
Cleveland, Ohio 44135

Abstract

The test facility presented herein uses a ground-based rocket combustor to test the durability of new ceramic composite and metallic materials in a rocket engine thermal environment. A gaseous H_2/O_2 rocket combustor (essentially a ground-based rocket engine) is used to generate a high temperature/high heat flux environment to which advanced ceramic and/or metallic materials are exposed. These materials can either be an integral part of the combustor (nozzle, thrust chamber etc) or can be mounted downstream of the combustor in the combustor exhaust plume. The test materials can be un-cooled, water cooled or cooled with gaseous hydrogen.

Introduction

The Research Combustion Lab (RCL) at the NASA Glenn Research Center consists of several small research facilities that are used to test advanced combustion processes and materials for advanced rocket engine concepts. These research facilities ("test cells") are located in several small buildings with two or three test cells in each building.

One of 10 test cells in the RCL, Cell 22 is primarily used for the testing of advanced ceramic composite materials for possible use in advanced rocket engines and other combustion devices. It is one of two test cells (the other being Cell 21) that are located in the same building. This building consists of two test cells, two control rooms and a shop area common to both as shown in figure 1. Cell 22 consists of two test stands. Mounted on each stand is a 4.45 kN (1000 lb_f) thrust class hydrogen gas/oxygen gas (GH_2/GO_2) rocket engine. On one stand (stand A) is mounted a typical "round" rocket engine with a 0.05 m (2.0 in.) diameter combustion chamber. A "square" engine, with a 0.06 x 0.06 m (2.3 x 2.3 in.) square combustion chamber is mounted on the second stand (stand B). The stands are located in a "garage" sized room that is open on one end so that the

engines exhaust outdoors. The round engine is capable of chamber pressures up to 6.90 MPa (1000 psia), the square engine, 3.45 MPa (500 psia). Mixture ratios (mass ratio of oxygen to hydrogen or O/F) for both engines can range from 1.5 to 8.0.

Prior to 2002, there was only one stand; what is now stand A, and it was used for both square and round engine programs. If, for example, a change in engine hardware from square to round (or vice-versa) was required, the square hardware had to be completely disassembled and the round engine hardware reassembled onto the same stand. A second stand was added so that one stand could be dedicated to round engine hardware and the other to square engine hardware, thus reducing buildup time between programs.

Square hardware is generally used to test 2-dimensional ceramic panels (typically 0.05 x 0.25 m (2x10 in.)), either un-cooled or cooled with either water or gaseous hydrogen, by mounting the test piece externally as an extension of the nozzle. The round hardware is typically used to test ablative nozzles, small (on the order of 0.01 x 0.05 m (0.5 x 2.0 in.) ceramic coupons that are either mounted externally or internally inside the thrust chamber and ceramic composite thrust chambers and nozzles.

Facility Overview

The Cell 21/22 complex consists of the previously described building, an exhaust tube/scrubber structure, GH_2/GO_2 tube trailers, high pressure water tanks and a CO_2 fire suppression system. Both engine rigs are located immediately inside the open end of the test cell and both exhaust into a separate exhaust tube. Each of these tubes lead into a larger horizontal scrubber tube which in turn leads to a large vertical scrubber tower. This exhaust system was built in the 1950's to "scrub" (remove by spraying with water) hazardous chemicals from the engine exhaust before the exhaust was introduced to the outside

atmosphere. It now simply serves as an exhaust duct and to some extent as a noise suppression system for the engine exhaust gases.

Pressurized gaseous tube trailers are used to supply both hydrogen and oxygen to the cell. They are separated from the test cell building and from each other by earthen mounds. A 4.92 kliter (1,300 gal) high pressure water tank is located outside the cell and supplies high pressure cooling water (up to 8.38 MPa (1,215 psia)) to the various engine and test components. A smaller 20 gallon high pressure water tank is located inside the cell and is used to supply 6.90 MPa (1,000 psia) cooling water to a small nozzle extension used on the square engine rig when testing 2-dimensional ceramic panels. A CO₂ fire suppression system is installed inside the cell and can be operated by the test cell operator from inside the control room in case of engine/system failure resulting in fire. A large liquid nitrogen dewar is used to supply gaseous nitrogen to the entire Research Combustion Lab, including Cell 22, for purging of lines, valve actuation, regulator loading and pressurization of high pressure water tanks.

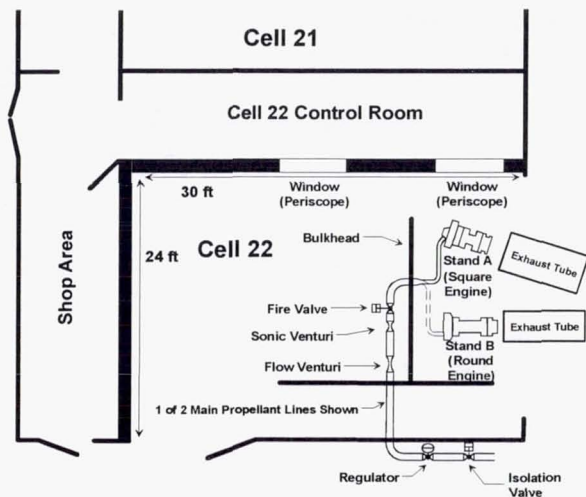

Figure 1. Test Cell Layout

The cell can be operated by a minimum of three to four people; an operations engineer, a mechanical technician and an electronics/instrumentation technician. An electrical engineer also splits his/her time between cells 21 and 22. To increase cell efficiency and decrease turn around time between programs a second operations engineer can also be used. This second

engineer can be used to prepare for an upcoming test program while the first engineer is conducting another test program. The second engineer can also help on more complex programs and can also assist the Cell 21 operations engineer.

Mechanical Systems

There are three "flow" systems that are used for each test firing of a rocket engine in Cell 22. The first is the propellant flow system used to supply both hydrogen and oxygen to the engine injector and igniter. The second is a gaseous nitrogen flow system used for line purging, regulator loading, valve actuation and water tank pressurization. The third system consists of both high and low pressure cooling water flow lines used to cool engine and test components while the engine is firing.

Propellant System

Cell 22 utilizes pressurized tube trailers to supply hydrogen and oxygen to the engine. When full, these trailers are pressurized to 16.7 MPa (2,415 psia). As testing progresses, a trailer "blows down" until such time that the pressure is too low to sustain flow to the engine. It is then replaced with a fully pressurized trailer. A fully loaded hydrogen trailer contains about 1.98 Mliters (70,000 standard cubic feet (SCF)) of hydrogen. This corresponds to approximately 168 kg (370 lb_m) of gaseous hydrogen. A fully loaded oxygen trailer contains about 1.4 Mliters (50,000 SCF), or 1,905 kg (4,200 lb_m) of gaseous oxygen. Figure 2 shows a simplified schematic of the hydrogen system.

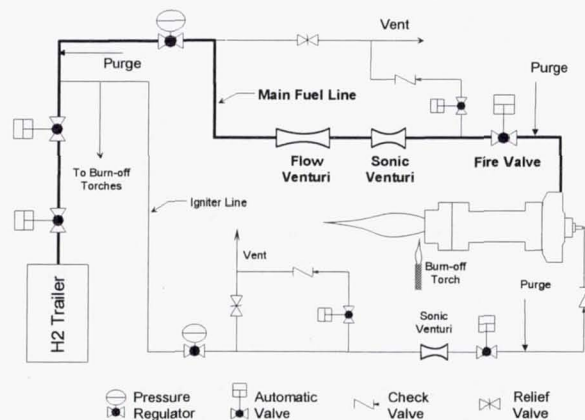

Figure 2. Simplified Hydrogen System Schematic

The principle components in the hydrogen flow system starting from the trailer are an isolation valve, a building valve (an isolation valve located near where the line passes into the cell), a pressure regulator, a flow measuring venturi, a sonic venturi and a fire valve. The oxygen flow system is almost identical in design. Between the building valve and the regulator are two smaller lines that branch off to supply hydrogen to the engine igniter and three burn-off torches. The engine igniter system is simply a smaller version of the main propellant line and consists of smaller versions of its own pressure regulator, sonic venturi and fire valve. The igniter is itself ignited with an ordinary spark plug.

The H₂/Air burn-off torches are located downstream of the engine; one at the nozzle exit and two in the exhaust duct. They are used to burn-off unburned hydrogen due either to firing at non-stoichiometric O/F ratios or unsuccessful engine ignition. The torches require extremely small flows of hydrogen and are mixed with air for combustion.

Operation of the rocket engine involves using the pressure regulators to control the pressure of the hydrogen and oxygen gases upstream of their respective sonic venturis. The mass flow through a choked (sonic velocity at the throat) venturi is a function of upstream pressure and temperature. By varying the upstream pressures ("set" pressures) of the venturis, different mixture ratios and chamber pressures can be obtained. Once these pressures are set, the main fire valves, igniter fire valves and the spark plug are operated in a predetermined sequence to initiate combustion in the combustion chamber.

Water System

There are several water coolant systems that are used to cool the engine and test articles during engine firing. The first of these is a 4.92 kliter (1,300 gal), 8.38 MPa (1,215 psia) water system. It consists of a 2.1 m (7 ft) diameter spherical pressure vessel and related plumbing. It is generally used to cool engine nozzles, combustion chambers and igniter rings. It is also used, if needed, to supply cooling water to test articles. It can supply up to 4,921 liter (1,300 gal) of 8.38 MPa (1,215 psia) ambient temperature water at rates up to 1.14 klpm (300 gpm). The tank is filled from a domestic water system supply which takes about 30 minutes.

The ability to de-ionize this water while the tank is filling is available. The second cooling system consists of a 75.7 liter (20 gal), 6.90 MPa (1000 psia) cylindrical water tank used to cool a small piece of copper that is commonly used in test programs that require the square rocket hardware. It is used to bridge the gap between the lower surface of the square nozzle and the test article. The flow rate needed to cool this copper "diving board" located immediately downstream of the nozzle is about 3.79 lpm (1 gpm). This system uses de-ionized water.

The third water system consists of a large 75.7 kliters (20,000 gal) cylindrical pit located at the base of the large vertical scrubber. As previously mentioned, this vertical tower structure was used in the 1950's to eliminate hazardous chemicals from rocket exhaust. The tower today is only used as an exhaust duct; the water in the pit however, is used for cooling the horizontal exhaust ducts located downstream of the engine. A multi-stage centrifugal pump is used to deliver water to the horizontal exhaust ducts. The water then drains back into the pit to form a closed loop system.

The use of domestic water to cool engine/test article assemblies that have very low cooling requirements is what makes up the fourth cooling water system. An inline pump can be used to boost the water pressure from 0.38 MPa (55 psia) to approximately 0.79 MPa (115 psia) and with a flow rate of about 492 lpm (130 gpm).

Nitrogen System

A large liquid nitrogen dewar is used to supply gaseous nitrogen to the entire rocket laboratory complex for valve actuation, loading of regulators, purging of propellant lines, pressurizing water cooling systems and cooling of test specimens. Nominal gaseous supply pressure is 16.65 MPa (2415 psia).

Gaseous Hydrogen Coolant System

The hydrogen coolant system can be used to cool test specimens. Hydrogen gas at ambient temperatures is supplied from the same tube trailers that supply the engine propellant lines. Flow rates of up to 0.68 kg/sec (1.5 lb_m/sec) can be delivered. The gas is then vented through a series of six vent stacks. The venting rate through each stack is below the requirement for burn-off torches.

Operational Limits/Capabilities

Table 1 provides a summary of maximum capabilities for Cell 22.

Table 1.—Cell 22 Capabilities

Parameter	Maximum or Range
Chamber pressure (Pc) Round Hardware Square Hardware	6.89 MPa (1000 psia) 3.45 Mpa (500 psia)
Mixture Ratio (GO ₂ /GH ₂)	1.5 to 8.0
GH ₂ flow rate (total)	1.81 kg/sec (4.0 lb _m /sec)
GH ₂ Coolant System	0.68 kg/sec (1.5 lb _m /sec)
GO ₂ flow rate	2.27 kg/sec (5.0 lb _m /sec)
High pressure water flow rate	1.14 klpm (300 gpm)
High pressure water pressure	8.27 Mpa (1200 psia)
Test duration	Up to approximately 9 minutes for low chamber pressures/water coolant needs.

An important test cell parameter is maximum test duration for the engine for a single run. The maximum test duration of the engine is limited by either the supply of GH₂, GO₂ or high pressure cooling water. It varies widely and is dependant on many variables, the two most important being test conditions (high or low chamber pressure, GH₂ coolant requirements etc.) and high pressure water coolant needs for both the engine and test articles. Prior to 1998 high pressure cooling water was supplied by a 568 liter (150 gal) tank which typically limited individual test runs to about 1 minute. This tank was replaced with a much larger 4.92 kliter (1,300 gal) vessel allowing for much longer test runs.

The round hardware engine components require approximately 492 lpm (130 gpm) (square hardware requires approximately 757 lpm (200 gpm)) of high pressure cooling water. Of the 4.92 kliters (1,300 gal) available with a full tank, about 4.54 kliters (1,200 gal) are available for a test run after allowing for bleeding air from lines and unavailability of a small quantity of water due to tank design. This allows for a maximum single run time of about 9 minutes for the round

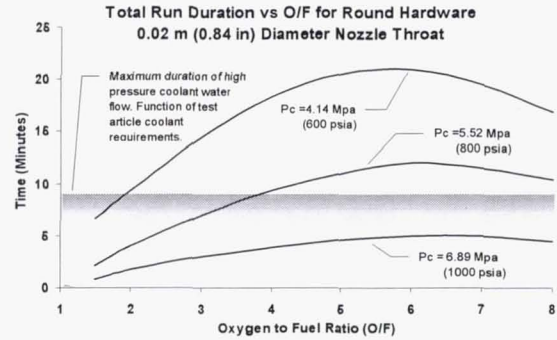

Figure 3. Maximum Test Duration for Round Hardware

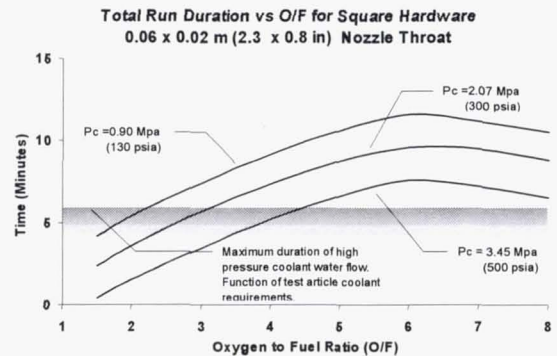

Figure 4. Maximum Test Duration for Square Hardware

hardware (about 6 minutes for square hardware) assuming there is enough GH₂ and GO₂ available for the given run conditions (chamber pressure and O/F). Any additional high pressure water required by a test article will result in maximum run times of less than 9 minutes. Maximum run times for round and square hardware for three different chamber pressures are shown in figures 3 and 4 as a function of O/F. The curves in these charts denote how many minutes the engine can be run in aggregate before one or both GH₂/GO₂ tube trailers need to be replaced. The horizontal shaded bar indicates maximum continuous run times due to high pressure cooling water supply limits.

The times shown in figures 3 and 4 are approximate. Certain test conditions may require sonic venturis and/or set pressures that are not ideally matched for those conditions resulting in shorter run times.

Electronic Systems

Programmable Logic Controller

A Modicon Quantum programmable logic controller (PLC) is used to operate the engine during a test firing. The PLC actuates the valves, controls the duration of the run and aborts the run if any engine or test parameters exceed predetermined limits. Timing information is input to the PLC through a Microsoft® Excel spreadsheet. This replaces the former method of inputting the timing values using mechanical thumbwheel switches that were used with the previous PLC. By using the computational and graphical tools of Microsoft® Excel, timing values can be easily changed, visually verified and archived faster and more efficiently than with the manual methods use in the past.

Abort System

A Magelis input screen is used to input abort limits to the PLC. This was added in 1999, replacing an in-house analog abort system. Sixteen automatic abort channels (an increase of six over the analog system), each providing an upper abort limit and a lower abort limit, are available for both facility and research hardware protection. Abort limits can be placed on pressure, temperature and flow parameters. Response time from when the abort signal is received to the beginning of fire valve closing is less than 50 msec. Overall system shutdown response is typically less than 0.5 seconds.

WonderWare InTouch®

WonderWare InTouch® is a software package that allows a personal computer to actuate valves by clicking (or touching if a touch screen is used) icons on a computer screen as opposed to mechanical pushbuttons on a console. Cell 22 uses the WonderWare system to control valves associated with the water coolant systems and to monitor permissives. As time permits other systems that currently use mechanical pushbuttons will be moved to the WonderWare system.

Instrumentation

Three types of instrumentation are used to measure engine, test article and facility parameters during a test: Pressure transducers, thermocouples (TCs) and liquid flowmeters.

Pressure transducers are of the strain gauge type and can be used to measure pressures from atmospheric to 20.7 Mpa (3000 psia) with an end to end system accuracy of < 1% of full scale. Three thermocouple reference ovens (302 °C. (150 °F) reference temperature) are available: K, R and E for temperature measurements up to 5,000 °C (2,800 °F). Inline turbine flowmeters are used to measure cooling water flowrates. They are available in sizes ranging from 9.5 lpm (2.5 gpm) to 1.14 klpm (300 gpm).

Signals from each transducer, thermocouple and flowmeter are routed by cable to a patchboard in the control room. The patchboard is then used to send the signals to various electronic systems in the control room, including a data acquisition PC, a strip chart recorder, the PLC, and the Magelis abort panel.

Data Acquisition

Prior to 1997, test data was collected by a high speed data system called TRADAR (TRANSient Data Acquisition and Recording). It was capable of recording 99 channels at a rate of 100 samples per second per channel. In 1997 this system was replaced with National Instruments LabVIEW software installed on a PC dedicated to test data collection. Cell 22 is currently using LabVIEW 5.1 on a 900 MHz PC to collect data and convert it to engineering units in real time. Data can be collected from the three instrument types described earlier. Currently 128 data channels are available at a sampling rate of 500 MHz/channel. Higher sampling rates are possible by using fewer data channels. Of the 128 data channels available, 50 can be used for pressure measurements, up to 12 can be used for flow measurements and all 128 can be used to measure temperatures if so desired.

Another PC is used to process the raw engineering data. A post-run processing FORTRAN code is used to calculate gas flowrates, engine conditions and research hardware parameters. The data for each channel can be averaged over a number of readings that is input by the user. For example, if data is collected at 500 samples for second, each consecutive block of 50 readings could be averaged such that the output contains data at 0.1 second intervals. The value at each interval represents the average of 50 readings centered about that point in time. An output file can be

generated within five minutes of the end of a run.

In addition to LabVIEW, a high speed strip chart recorder is used to monitor engine parameters such as chamber pressures, injector pressure drops and venturi set pressures. A channel can also be set aside for research data if it is desired to observe a research measurement in real time. The chart recorder can display up to 16 channels of data, which are recorded as analog differential input signals digitized at a rate of 200 kilosamples per second per channel, with a bandwidth of 20 MHz.

Two conventional color video cameras and VCRs are used to record each run. The actuation of the VCRs is controlled automatically by the PLC. One camera is located above the test rig, the other is mounted on a tripod and can be positioned wherever desired to give a "side" view of each test run. A 35 mm camera can also be mounted above the rig or on a tripod and can be triggered by the PLC to continually take pictures for a given length of time during the run.

Figure 5 is a schematic showing the interrelationship between the various electronic systems.

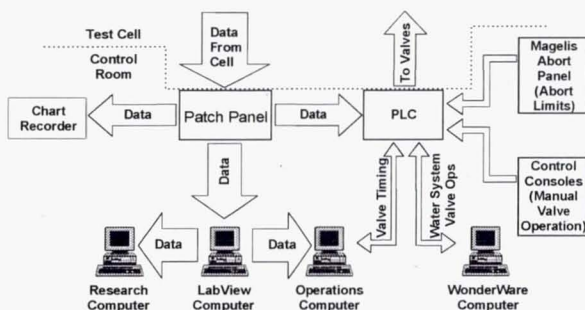

Figure 5. Electronic Systems

Addition of Second Test Stand

The most significant change to cell 22, since its capabilities were last documented,¹ is the addition of a second test stand in early 2002. The original stand (Stand A) is now permanently configured for test programs that require the round engine hardware. The second stand (Stand B) is configured for test programs that require square hardware. Having a test stand dedicated for each type of program decreases hardware teardown and buildup times between

test programs. This results in an increase in both cell efficiency and cost savings.

Each stand has its own set of instrumentation which share a common set of instrumentation cabling to the control room. Only the stand that is in operation has its instrumentation wired to the control room. The change from one stand to the other is mostly transparent in terms of data acquisition and test operations.

Transitioning from one stand to the other involves physically rerouting fuel and oxidizer lines downstream of the fire valves, switching the instrumentation cabling from the control room from one stand's set of instrumentation to the other and operating a small number of hand valves to reroute cooling water. Each stand also has its own dedicated patchboard which allows for any changes in research instrumentation requirements for an upcoming test program to be made while another testing program is in progress.

Rocket Engine (Combustor) Hardware

Combustor hardware can be designed and fabricated specifically for test programs in Cell 22 given enough time and financial resources. However, most research programs adapt their test rigs to conform to existing combustor hardware that is commonly used in the test cell. The combustors used are of two types that differ primarily in geometry. One is a typical "round" combustor design, the other is a "square" design.

Round Combustor Hardware

The round hardware consists of three elements; injector, combustion chamber and nozzle. All the elements are designed around a 0.05 m (2.0 in.) diameter combustion chamber. The combustor chamber and nozzle both consist of a copper inner liner inside of an electroformed nickel jacket. The "cold" side of the copper inner liner, the side in contact with the nickel jacket, consists of longitudinal cooling water channels. High pressure water is used to cool the copper liner when combustion is taking place during a test firing.

Metal combustion chambers are available in several lengths ranging from 0.15 to 0.30 m (6 to 12 in.). The research community can also provide a combustion chamber. Combustion

chambers consisting of experimental copper alloys have been tested in Cell 22 along with un-cooled ceramic composite chambers. Water cooled nozzles of the same copper liner/nickel jacket design are available in two throat diameters; 0.015 and 0.021 m (0.60 and 0.84 in.). Copper heat sink nozzles are also in various throat sizes for runs of 2 or 3 second duration. Non-metal research nozzles, nozzle inserts and nozzle extensions can also be used.

Square Combustor Hardware

The square hardware used in Cell 22 was originally designed and built in the late 1980's to provide a high heat flux source that would simulate the heat flux experienced by the blades in the space shuttle engine's high-pressure fuel turbopumps.^{3,4} This square engine was then used to test the durability of thermal barrier coatings being investigated for use on these blades. It has since been adapted for use in testing ceramic composite materials. The square hardware consists of the same three elements as the round with the addition of an igniter ring and is of the same copper inner liner/nickel jacket design as the round hardware. Square combustor chambers are 0.015 m (6.0 in.) long. Square nozzles have a throat size of 0.058 by 0.020 m (2.3 by 0.8 in.).

Engine Igniter

The same hydrogen-oxygen spark torch igniter² is used in both square and round hardware but is positioned differently in each hardware assembly. The igniter is, in many respects, a miniature version of the larger combustor. Two small lines feed the igniter combustion chamber with gaseous hydrogen and oxygen and a marine outboard engine spark plug is used to ignite the mixture. The design and operation of the igniter are such that it does not need to be water cooled.

For the round hardware injector, the igniter is inserted directly through the injector concentric with the centerline of the engine. For the square hardware, a separate igniter (combustor) ring is inserted between the combustor chamber and

injector with the igniter inserted through one side of the combustor ring, perpendicular to the centerline of the engine.

Test Articles

Test articles are usually held in place with holders that are specifically designed for each test program. Future test programs can design test hardware to existing holders or, if enough lead time is allowed, have holders fabricated.

Conclusion

Test Cell 22 at the NASA Glenn Research Center is a rocket engine facility that is capable of producing a wide range of GH_2/GO_2 environmental conditions for testing a variety of advanced ceramic composite and metallic materials. The addition of a second test stand, a larger high pressure water supply, along with the replacing and upgrading of the data collection system have improved both the test run and data throughput of Cell 22 since its capabilities were last documented.¹ Much longer single test run times are possible along with greater flexibility in changing test parameters between successive runs. These changes and others to follow will continue to make Cell 22 an essential test cell facility for research into advanced ceramic composites and metallic materials for future rocket engine and other advanced propulsion concepts.

References

1. Green, J.G., "A Versatile Rocket Engine HotGas Facility," NASA Contractor Report 195339, June 1993.
2. Repas, G.A., "Hydrogen-Oxygen Torch Igniter," NASA TM-106493, March 1994.
3. Nesbitt, J.A., and Brindley, W.J., "Heat Transfer to Throat Tubes in a Square Chambered Rocket Engine at the NASA Lewis Research Center," NASA TM-102336.
4. Nesbitt, J.A., "Thermal Response of Various Thermal Barrier Coatings in a High Heat Flux Rocket Engine," Surface and Coatings Technology, 43/44 (1990) 458-469.