



US009090315B1

(12) **United States Patent**  
**Stone et al.**

(10) **Patent No.:** **US 9,090,315 B1**  
(45) **Date of Patent:** **Jul. 28, 2015**

(54) **OPTICAL ENERGY TRANSFER AND CONVERSION SYSTEM**

(75) Inventors: **William C. Stone**, Del Valle, TX (US);  
**Bartholomew P. Hogan**, Gaithersburg, MD (US)

(73) Assignee: **Piedra—Sombra Corporation, Inc.** TX (US)

4,580,399 A 4/1986 Henrich  
4,961,545 A 10/1990 LeCompte  
5,022,603 A 6/1991 Maree et al.  
5,044,573 A 9/1991 Le Compte  
5,058,969 A 10/1991 Peterson et al.  
5,074,489 A 12/1991 Gamzon  
5,099,144 A 3/1992 Sai  
5,152,135 A 10/1992 Kare

(Continued)

(\* ) Notice: Subject to any disclaimer, the term of this patent is extended or adjusted under 35 U.S.C. 154(b) by 497 days.

FOREIGN PATENT DOCUMENTS

JP 63113256 A \* 5/1988 ..... F24J 3/00  
JP 2002193555 A \* 7/2002 ..... B65H 75/14

(Continued)

(21) Appl. No.: **13/303,449**

(22) Filed: **Nov. 23, 2011**

**Related U.S. Application Data**

(60) Provisional application No. 61/416,676, filed on Nov. 23, 2010.

(51) **Int. Cl.**  
**G02B 6/34** (2006.01)  
**B63B 35/12** (2006.01)  
**F25C 5/08** (2006.01)  
**E01H 5/10** (2006.01)

(52) **U.S. Cl.**  
CPC . **B63B 35/12** (2013.01); **F25C 5/08** (2013.01);  
**E01H 5/10** (2013.01)

(58) **Field of Classification Search**  
CPC .. G02B 6/3636; G02B 6/3652; G02B 6/3839;  
G02B 6/4471; B63B 35/12; E01H 5/10;  
F25C 5/08  
USPC ..... 385/137; 175/16  
See application file for complete search history.

(56) **References Cited**

U.S. PATENT DOCUMENTS

3,825,211 A 7/1974 Minovitch  
4,354,645 A 10/1982 Glavas et al.  
4,379,217 A \* 4/1983 Youmans ..... 219/121.6

OTHER PUBLICATIONS

Zimmerman, W.; Bonitz, R.; Feldman, J., "Cryobot: an ice penetrating robotic vehicle for Mars and Europa," Aerospace Conference, 2001, IEEE Proceedings., vol. 1, No., pp. 1/311,1/323 vol. 1, 2001.\*

(Continued)

Primary Examiner — Peter Radkowski

(74) *Attorney, Agent, or Firm* — Miguel Villarreal, Jr.; Gunn, Lee & Cave, P.C.

(57) **ABSTRACT**

An optical power transfer system comprising a fiber spooler, a fiber optic rotary joint mechanically connected to the fiber spooler, and an electrical power extraction subsystem connected to the fiber optic rotary joint with an optical waveguide. Optical energy is generated at and transferred from a base station through fiber wrapped around the spooler, through the rotary joint, and ultimately to the power extraction system at a remote mobility platform for conversion to another form of energy.

**17 Claims, 34 Drawing Sheets**

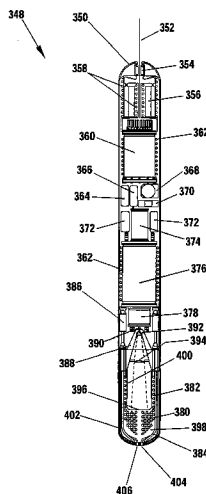

(56)

References Cited

U.S. PATENT DOCUMENTS

5,161,208 A 11/1992 Christie et al.  
 5,248,931 A 9/1993 Flesner et al.  
 5,260,639 A 11/1993 De Young et al.  
 5,402,966 A 4/1995 von Hoessle  
 5,436,553 A 7/1995 Pepper et al.  
 5,488,955 A \* 2/1996 Dias ..... 600/459  
 5,503,350 A 4/1996 Foote  
 5,686,694 A 11/1997 Hillenbrand et al.  
 5,719,376 A \* 2/1998 Snyder et al. .... 219/121.85  
 5,748,102 A 5/1998 Barron  
 6,167,831 B1 1/2001 Watt et al.  
 6,223,675 B1 5/2001 Watt et al.  
 6,257,162 B1 7/2001 Watt et al.  
 6,390,012 B1 5/2002 Watt et al.  
 6,411,565 B1 6/2002 Sirmalis et al.  
 6,534,705 B2 3/2003 Berrios et al.  
 6,669,126 B1 12/2003 Albert et al.  
 6,910,658 B1 6/2005 Hart et al.  
 6,964,509 B2 11/2005 Gozum et al.  
 6,968,112 B2 \* 11/2005 Zamel et al. .... 385/136  
 7,263,245 B2 8/2007 Delcher et al.  
 7,356,209 B2 4/2008 Delcher et al.  
 7,540,255 B2 6/2009 Hawkes  
 7,599,583 B2 10/2009 Levinson  
 7,786,419 B2 8/2010 Hyde et al.  
 7,854,267 B2 12/2010 Smith et al.  
 7,859,071 B2 12/2010 Levinson  
 8,369,673 B2 2/2013 Hawkes et al.  
 8,556,538 B2 10/2013 Hawkes et al.  
 8,616,805 B2 12/2013 Hawkes et al.  
 2002/0174642 A1 \* 11/2002 Gentry et al. .... 57/7  
 2004/0182732 A1 \* 9/2004 Zamel et al. .... 206/389  
 2005/0133203 A1 \* 6/2005 Farrow et al. .... 165/104.33  
 2006/0071116 A1 \* 4/2006 Quenneville et al. .... 242/557

2006/0289724 A1 12/2006 Skinner et al.  
 2008/0235418 A1 9/2008 Werthen et al.  
 2009/0086309 A1 \* 4/2009 Moosburger ..... 359/326  
 2009/0206697 A1 8/2009 Marshall et al.  
 2009/0251271 A1 \* 10/2009 Stelzer et al. .... 336/208  
 2009/0296746 A1 12/2009 Heaton et al.  
 2010/0025003 A1 2/2010 Smith et al.  
 2010/0044106 A1 2/2010 Zediker et al.  
 2010/0078995 A1 4/2010 Hyde et al.  
 2010/0079000 A1 4/2010 Yamamota et al.  
 2010/0079008 A1 4/2010 Hyde et al.  
 2010/0079009 A1 4/2010 Hyde et al.  
 2010/0079010 A1 4/2010 Hyde et al.  
 2010/0079011 A1 4/2010 Hyde et al.  
 2010/0079012 A1 4/2010 Hyde et al.  
 2010/0215326 A1 8/2010 Zediker et al.  
 2011/0299819 A1 \* 12/2011 Hawkes et al. .... 385/100

FOREIGN PATENT DOCUMENTS

WO 2010096086 8/2010  
 WO 2010144160 12/2010  
 WO 2012012436 10/2012

OTHER PUBLICATIONS

NASA JPL ("Subsurface Ice Probe. Small samples of ice would be melted and pumped to the surface for analysis," NASA Tech Briefs, Jan. 2005, pp. 24-25.\*  
 Akiyama, A., Shibata, M., Araki, S. and Ishii, H. (2002), A theory of unwinding optic fibers motion for fiberoptic data link bobbin. Electron. Comm. Jpn. Pt. I, 85: 61-73.\*  
 Bowen et al., Exploring the Deepest Depths: A Novel Light-Tethered Hybrid ROV for Global Science in Extreme Environments, Research Infrastructure MTS. Summer 2004 vol. 38, No. 2.\*

\* cited by examiner

Theoretical Attenuation Limits of Optical Power  
as a function of Wavelength per Kilometer of Fiber

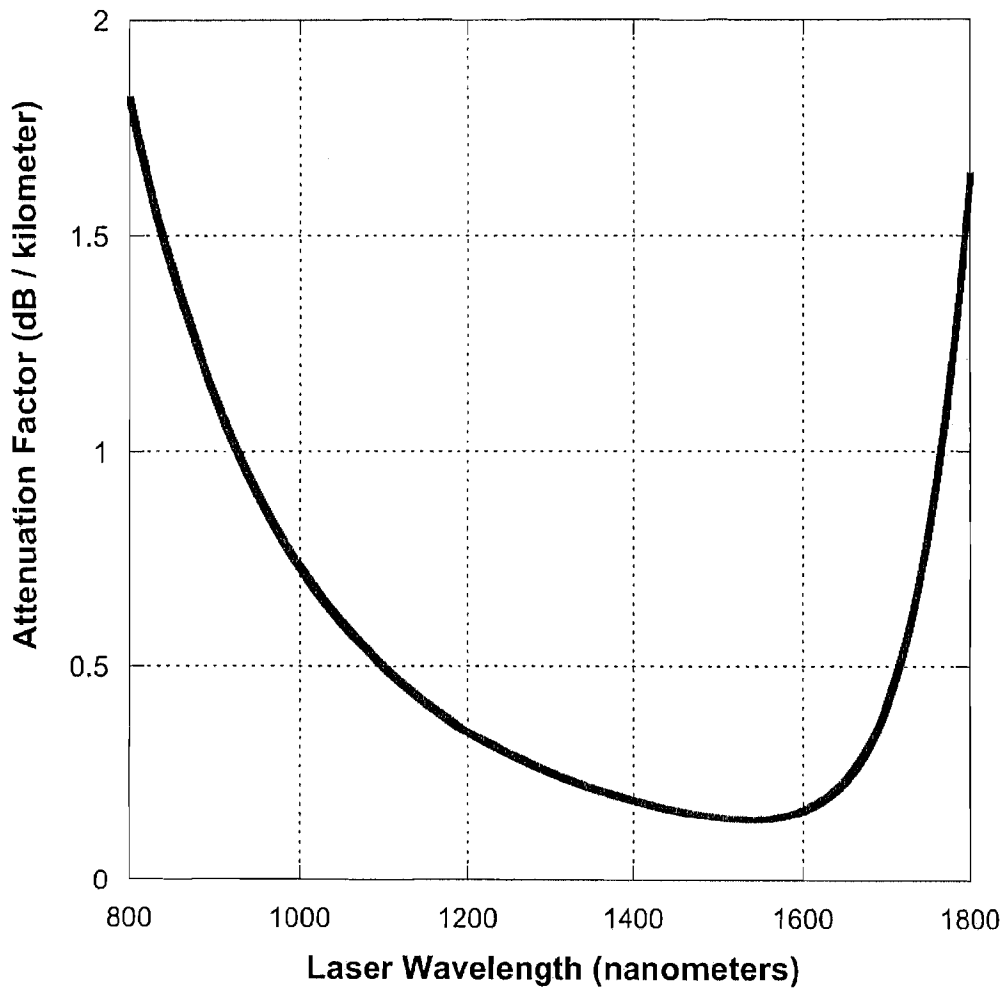

Fig. 1A

Present Power Delivery (kilowatts) versus  
Fiber Length (kilometers) for a  
1 Megawatt input at 1550 nm Wavelength

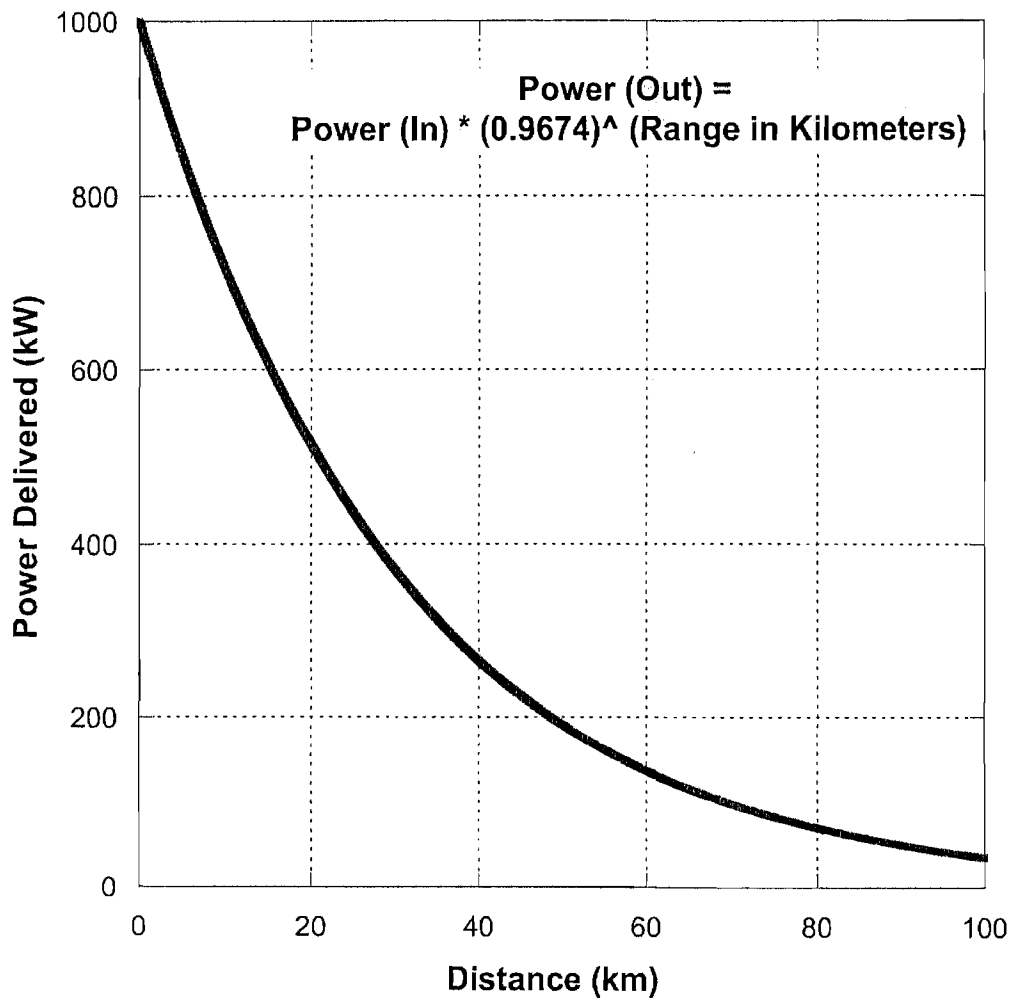

Fig. 1B

### High Power Fiber Transmission Tests

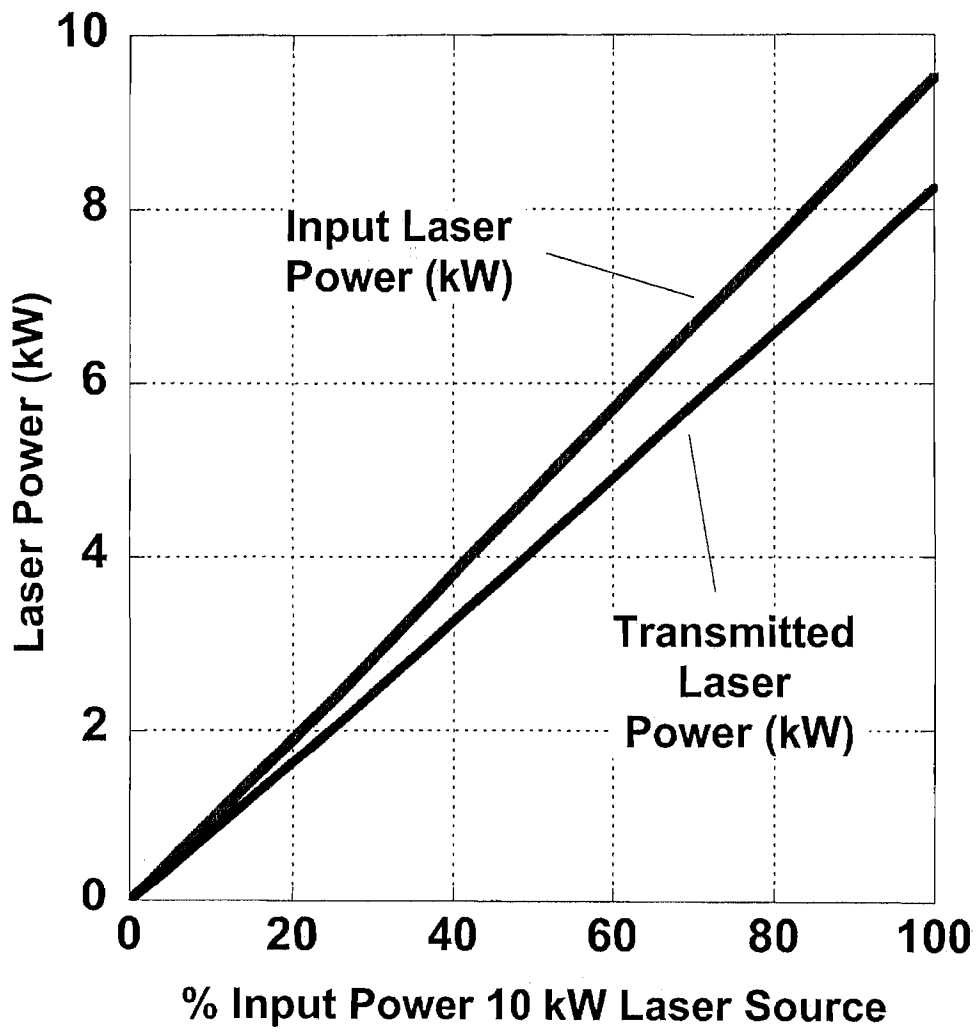

Fig. 2

Raw Power (Watts) for Single Mode Fiber Lasers from 1994 to 2010

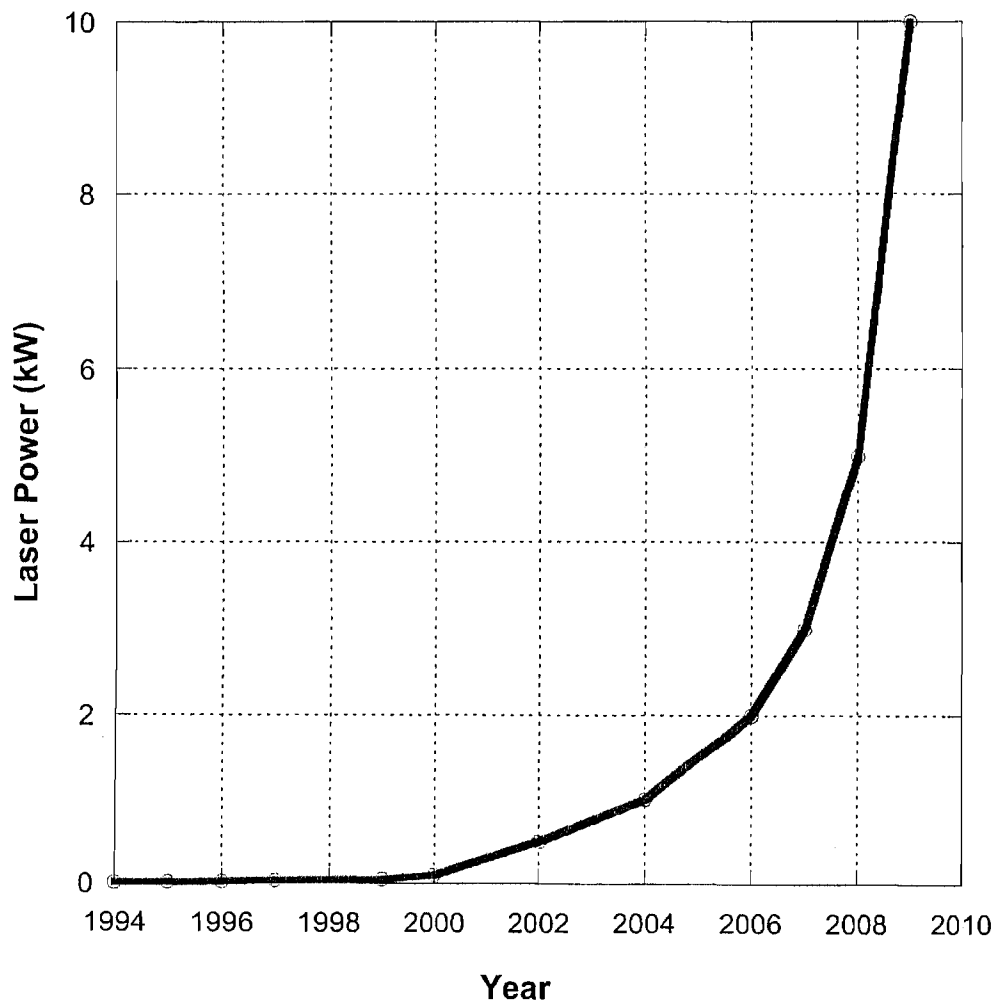

Fig. 3A

Power Density (MW/cm<sup>2</sup>) for Single Mode Fiber Lasers from 1994 to 2010

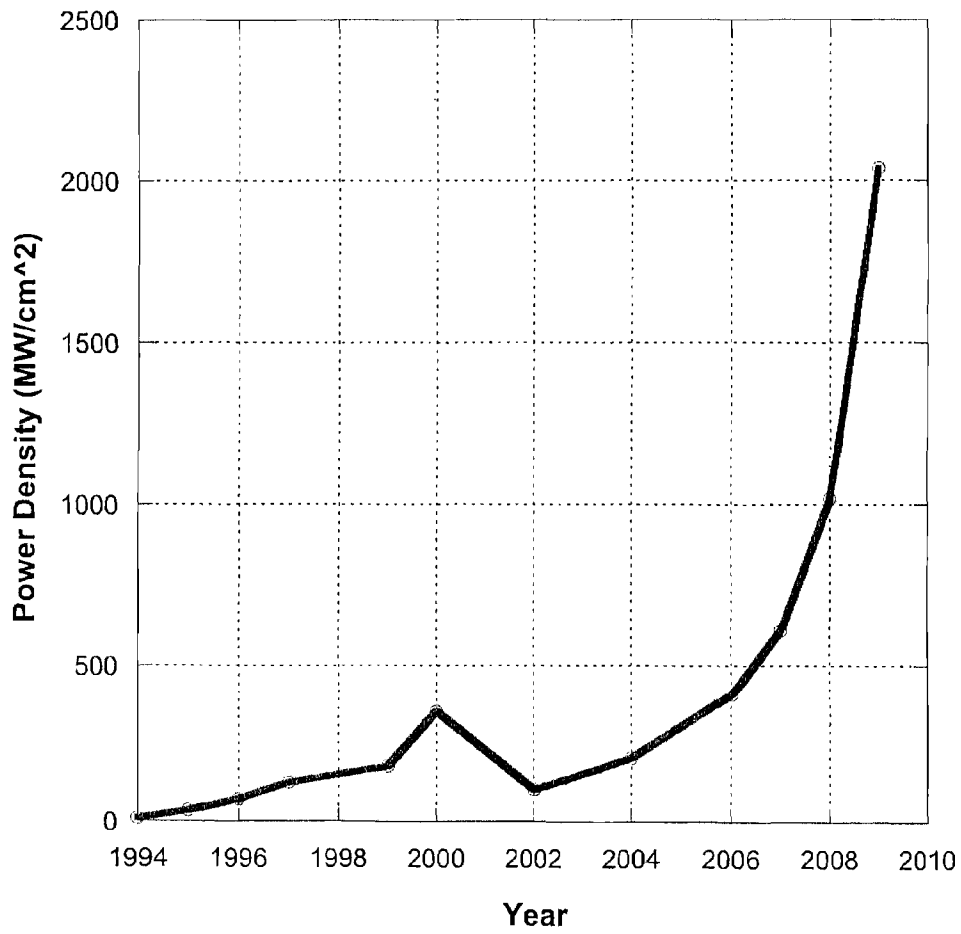

Fig. 3B

LOG Power Density (MW/cm<sup>2</sup>) for Single Mode Fiber Lasers  
from 1994 to 2010

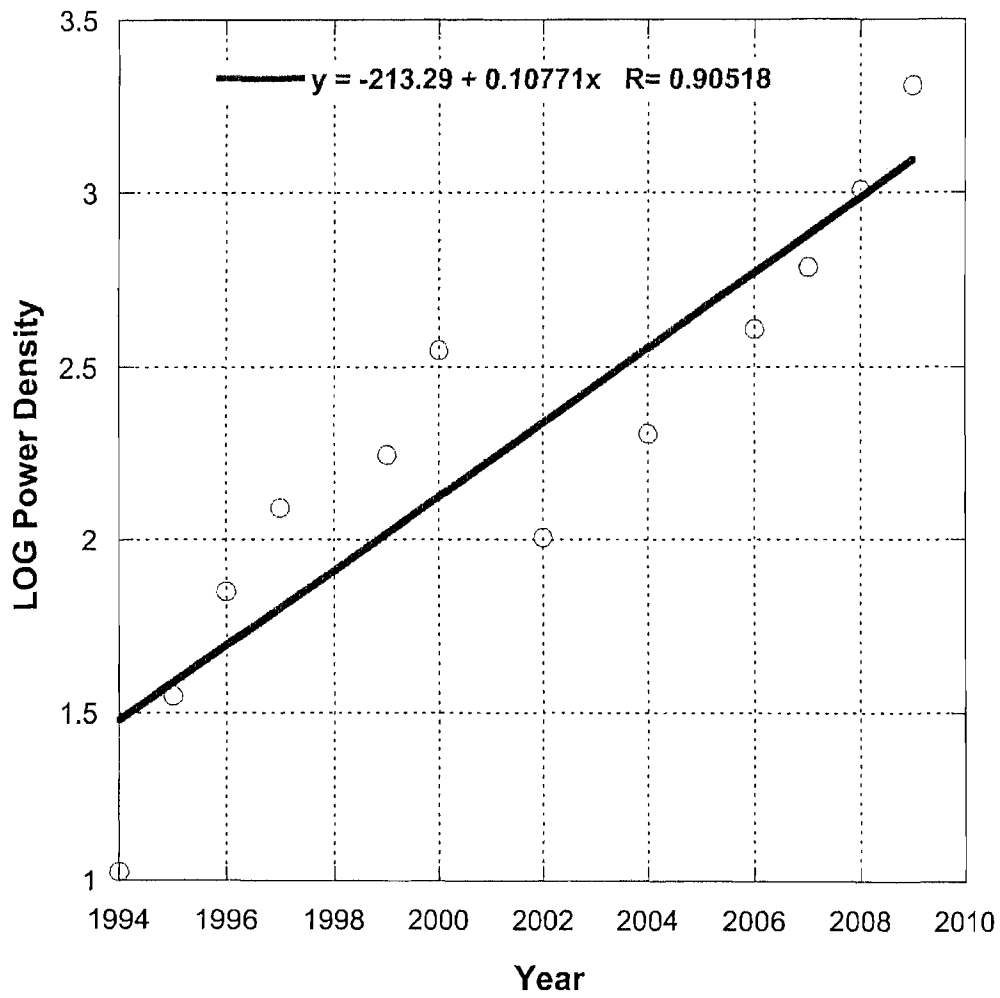

Fig. 3C



Present Optical Power Transmission as a function of Fiber Core Diameter

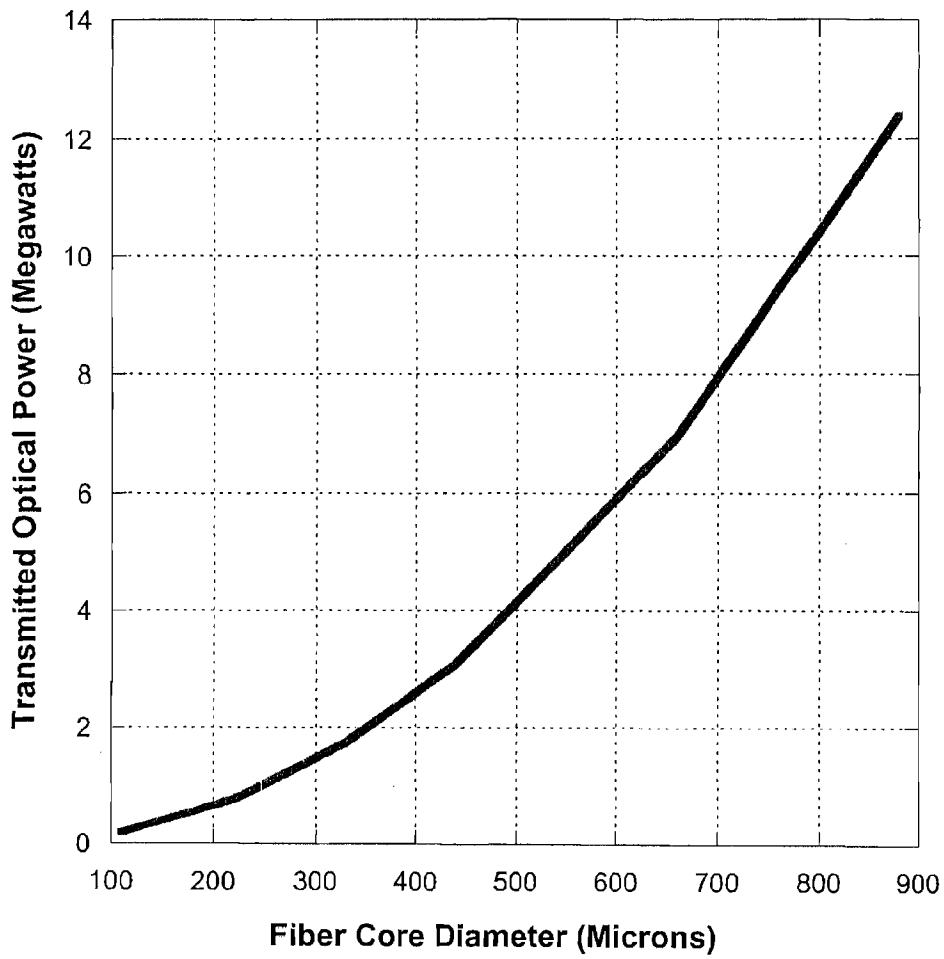

Fig. 3D

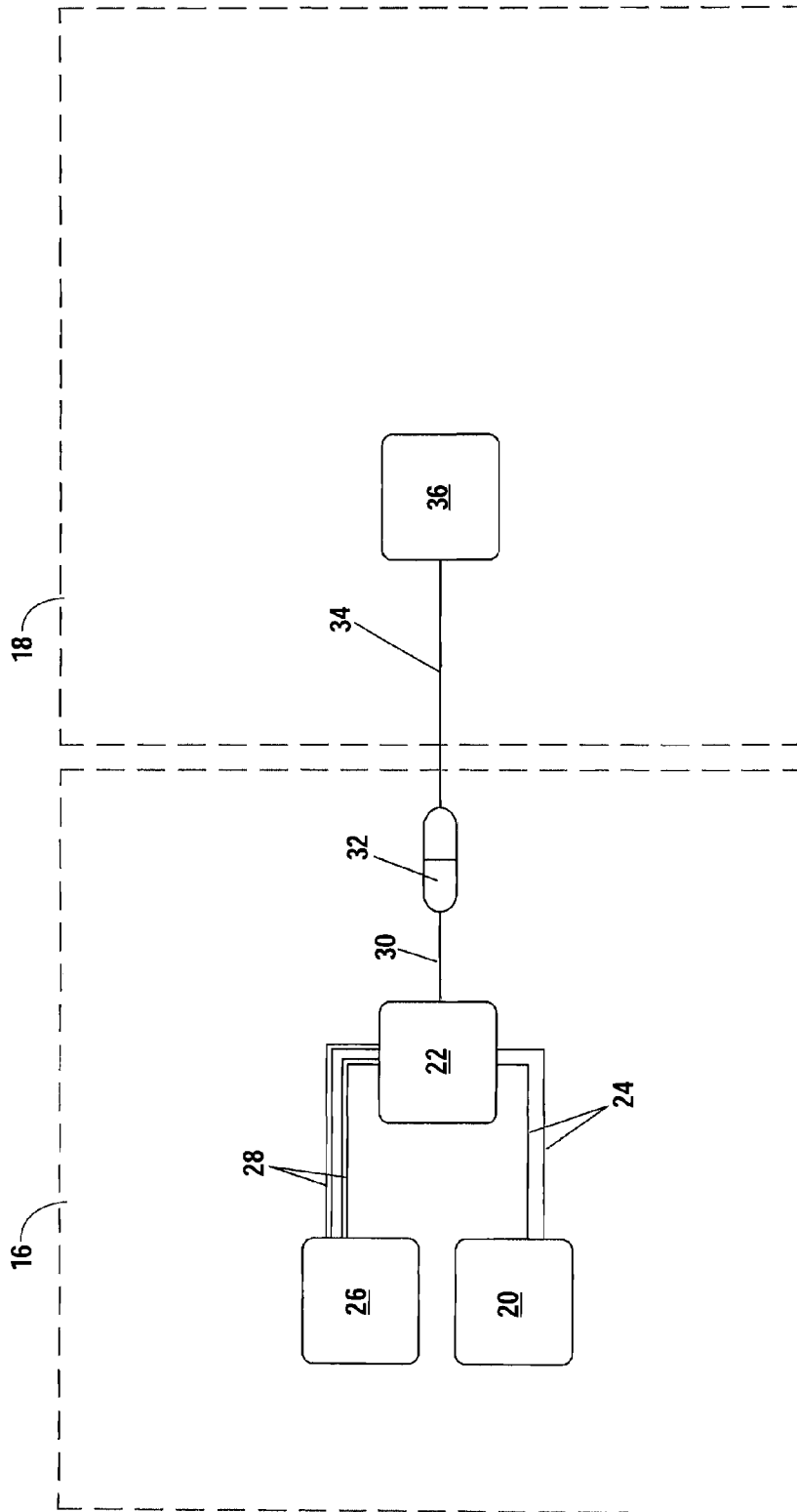

Fig. 4

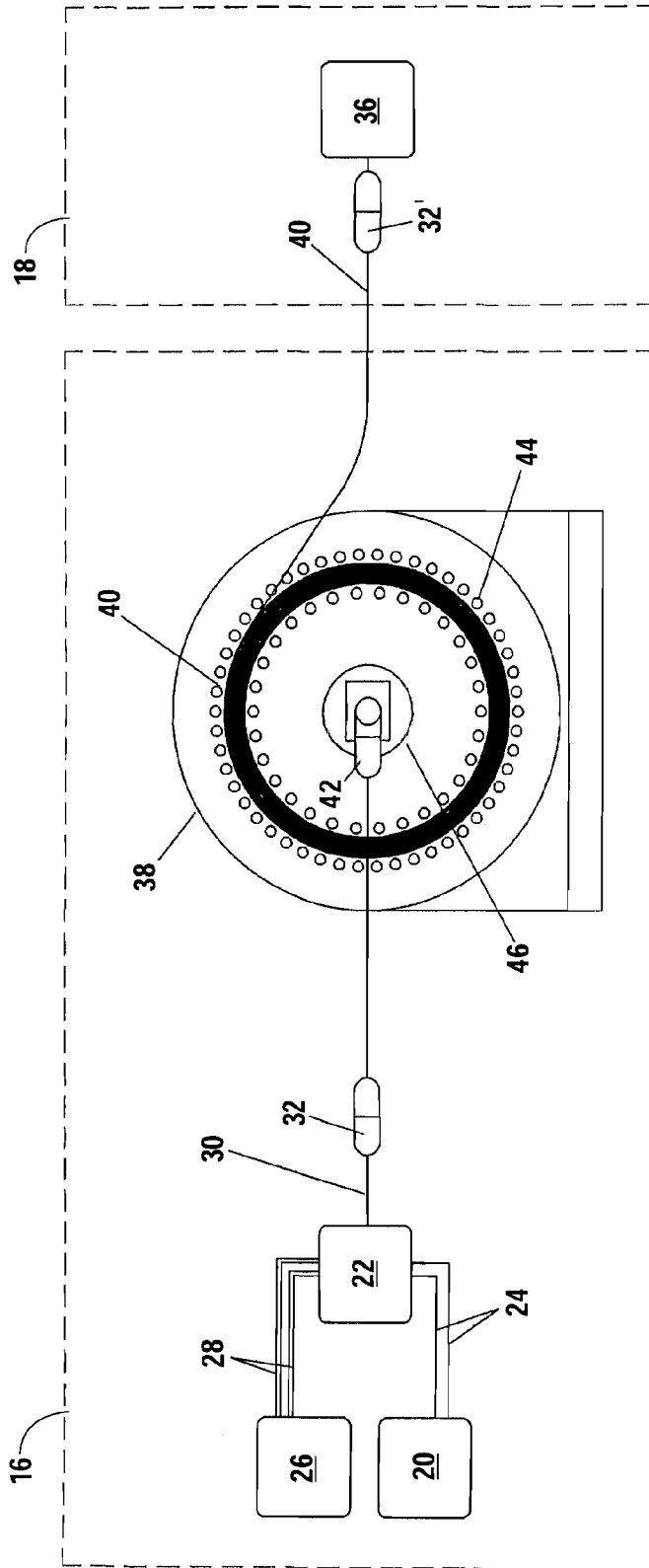

Fig. 5A

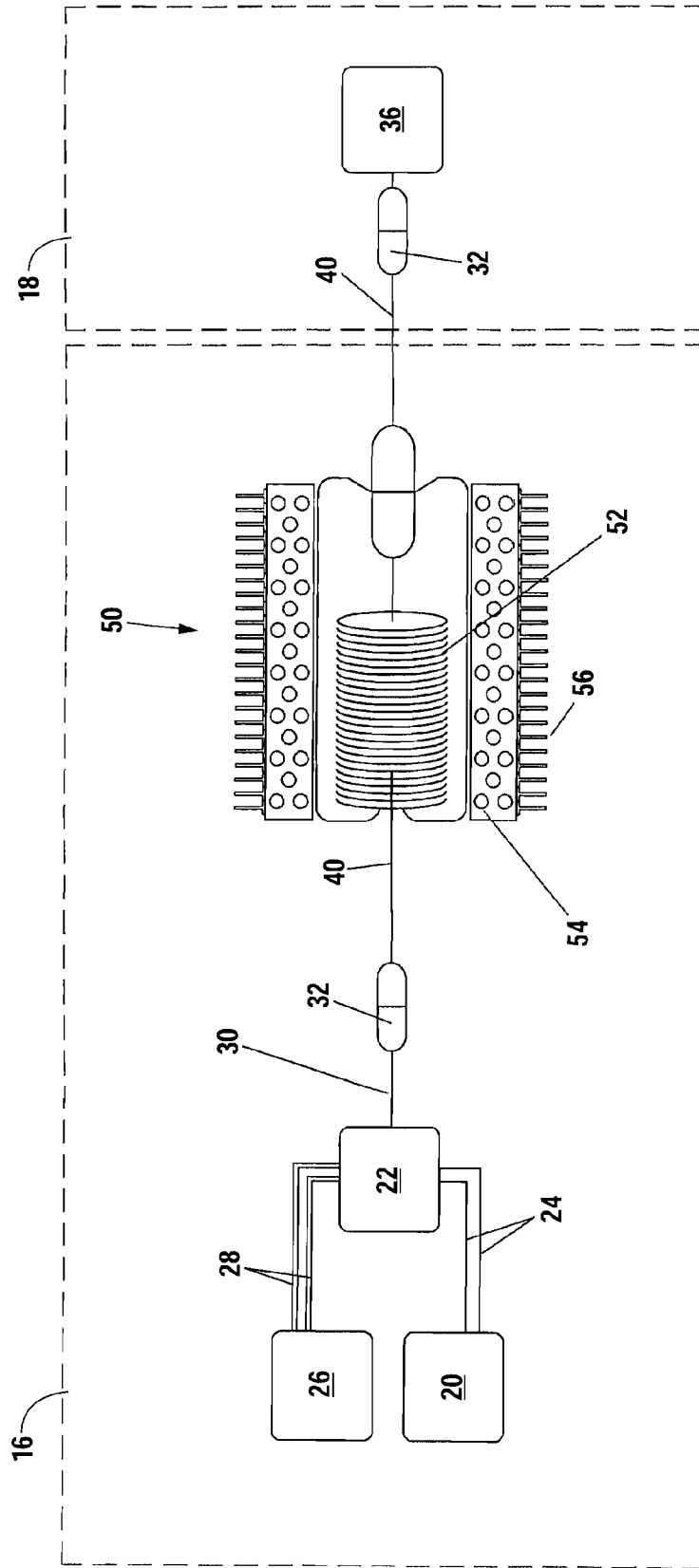

Fig. 5B

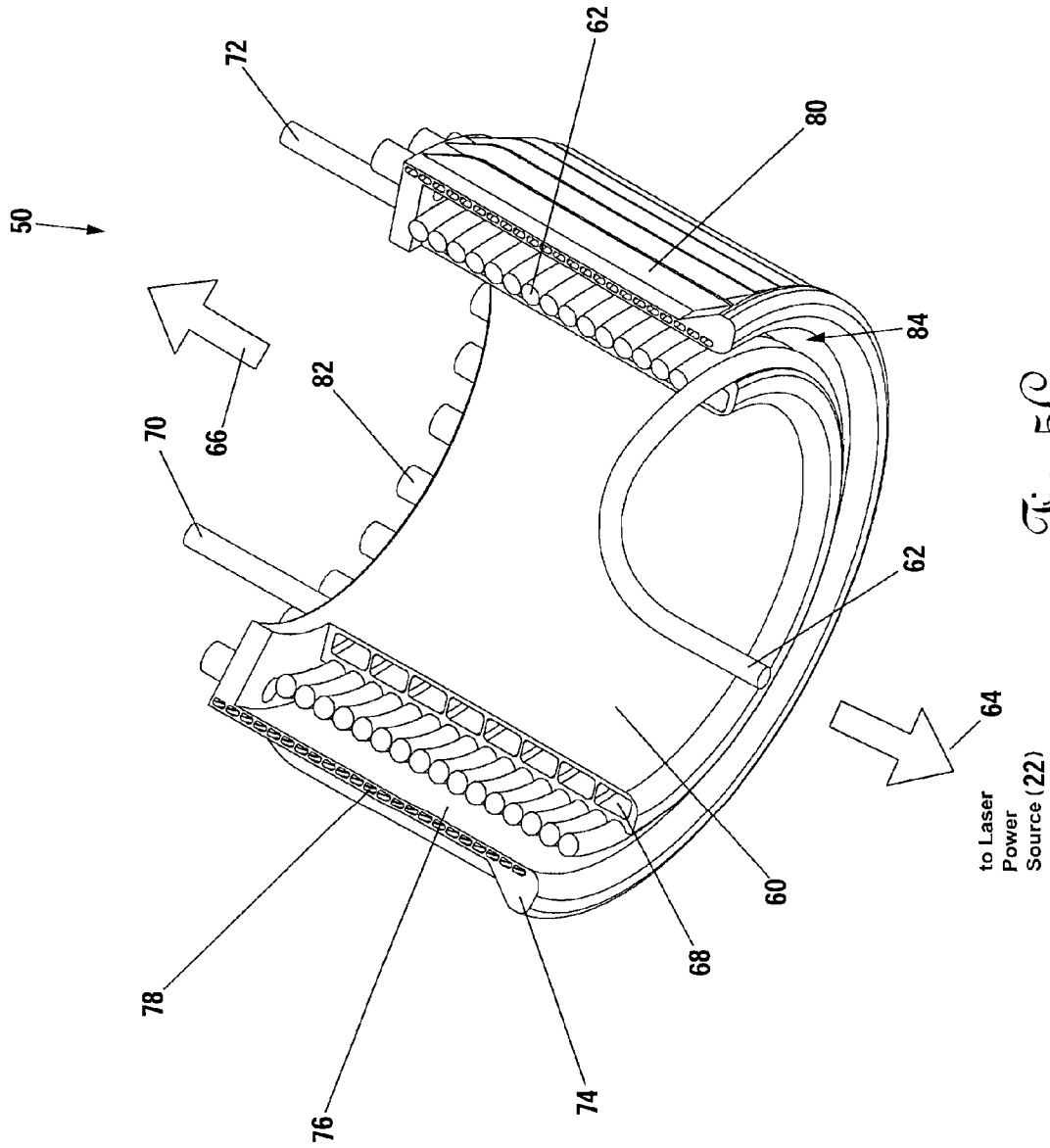

Fig. 5C

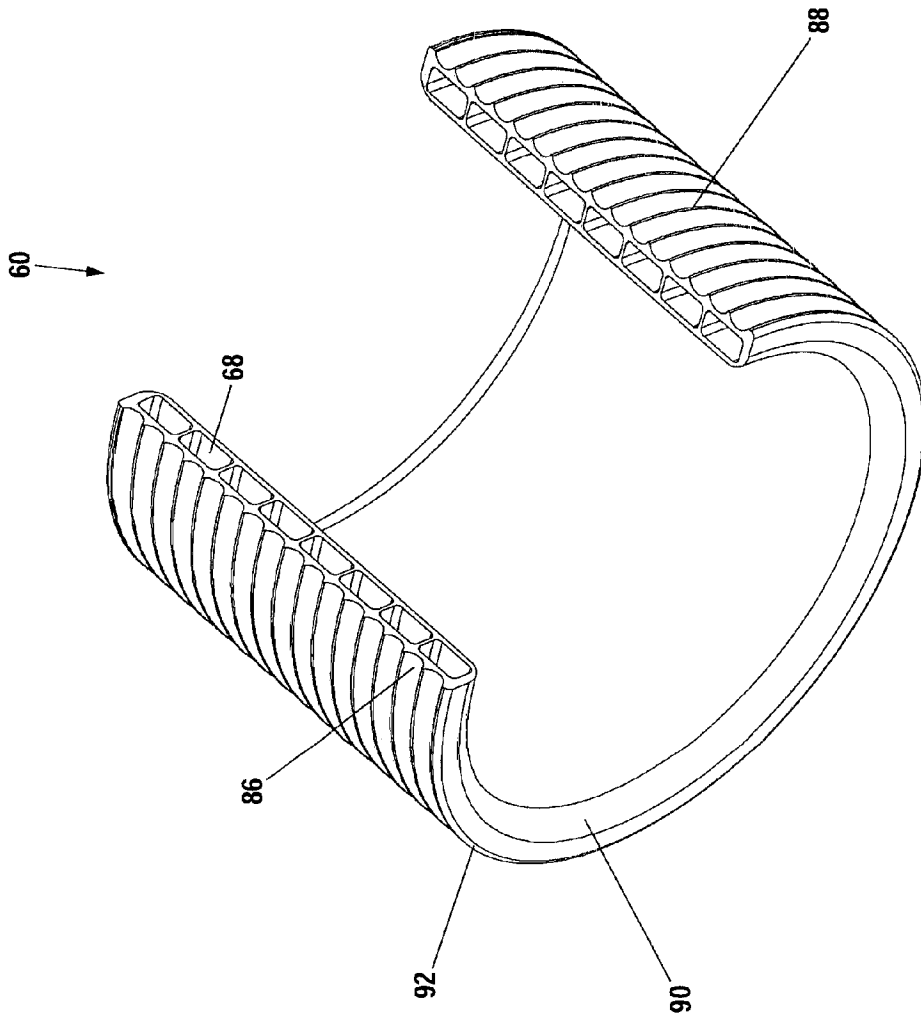
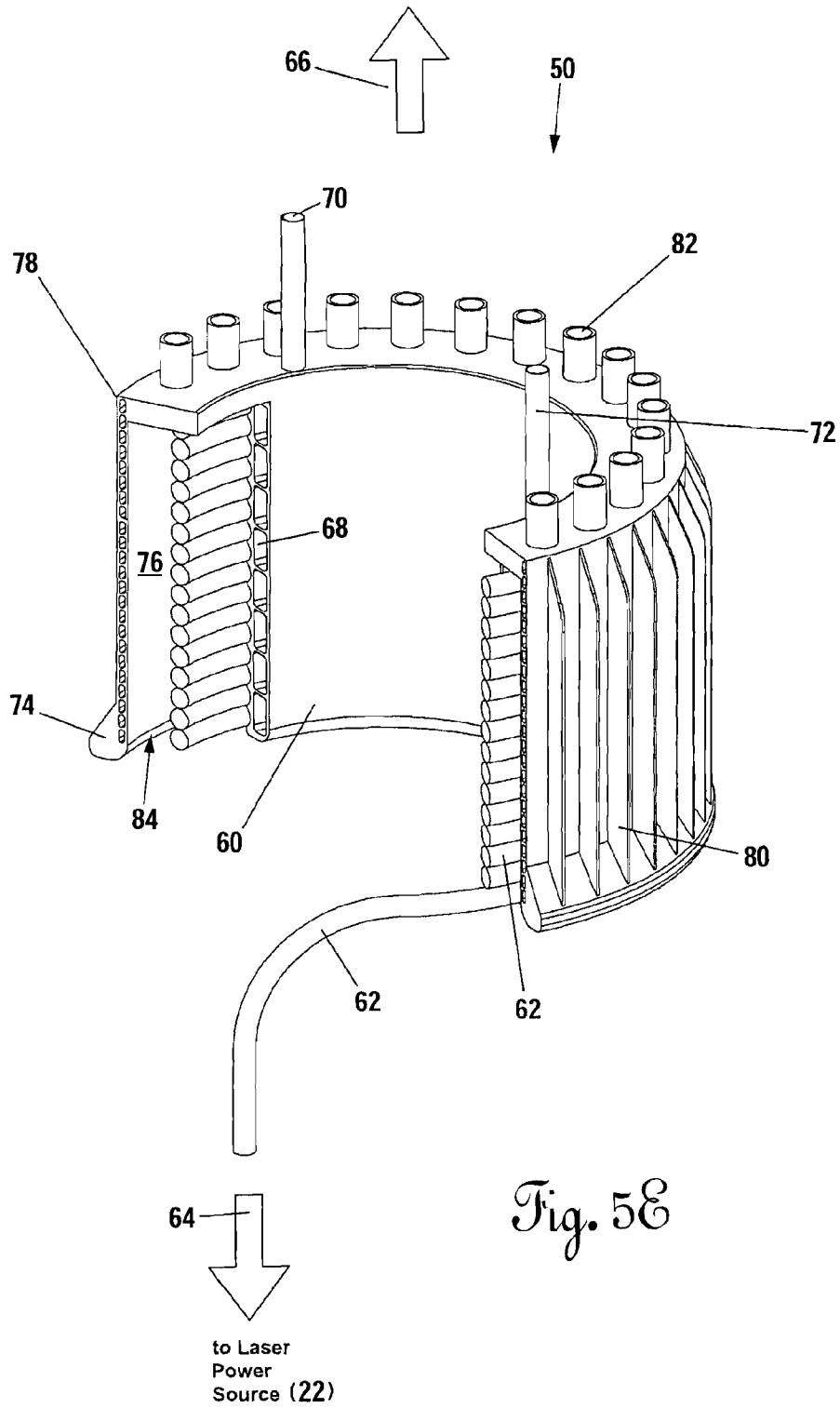

Fig. 5D



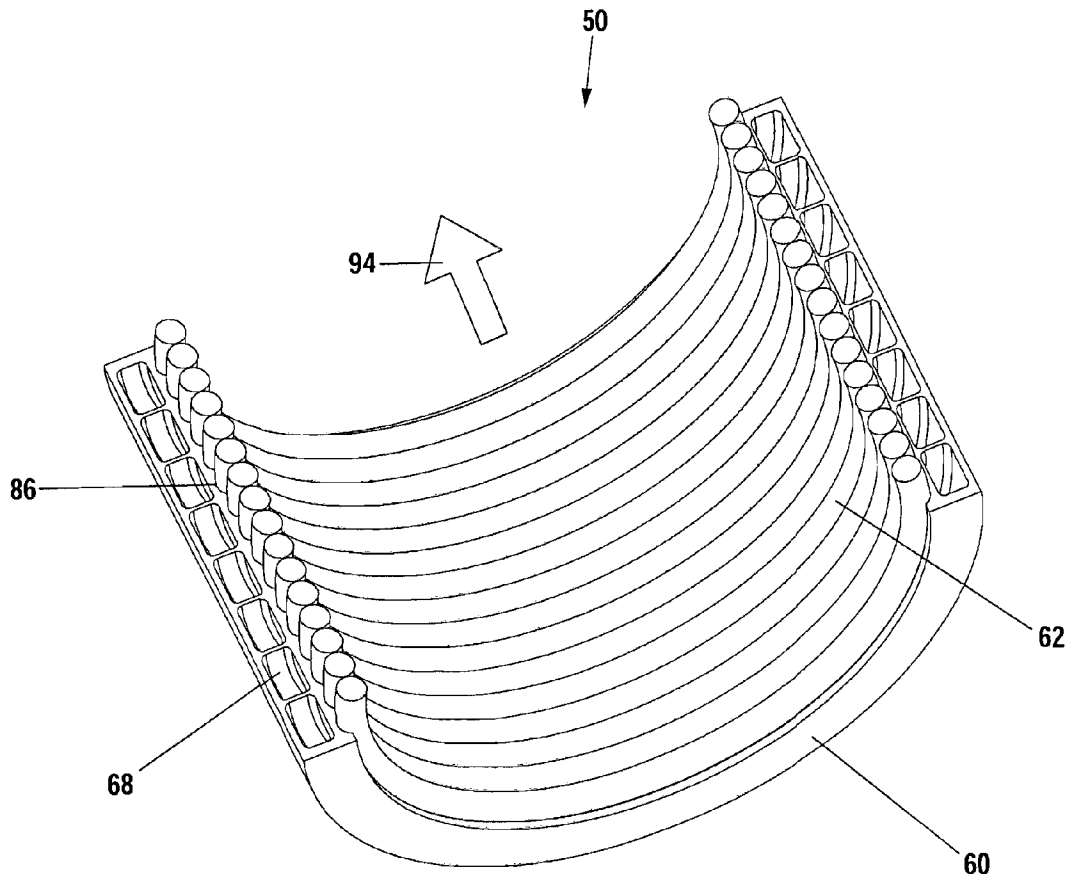

Fig. 5F



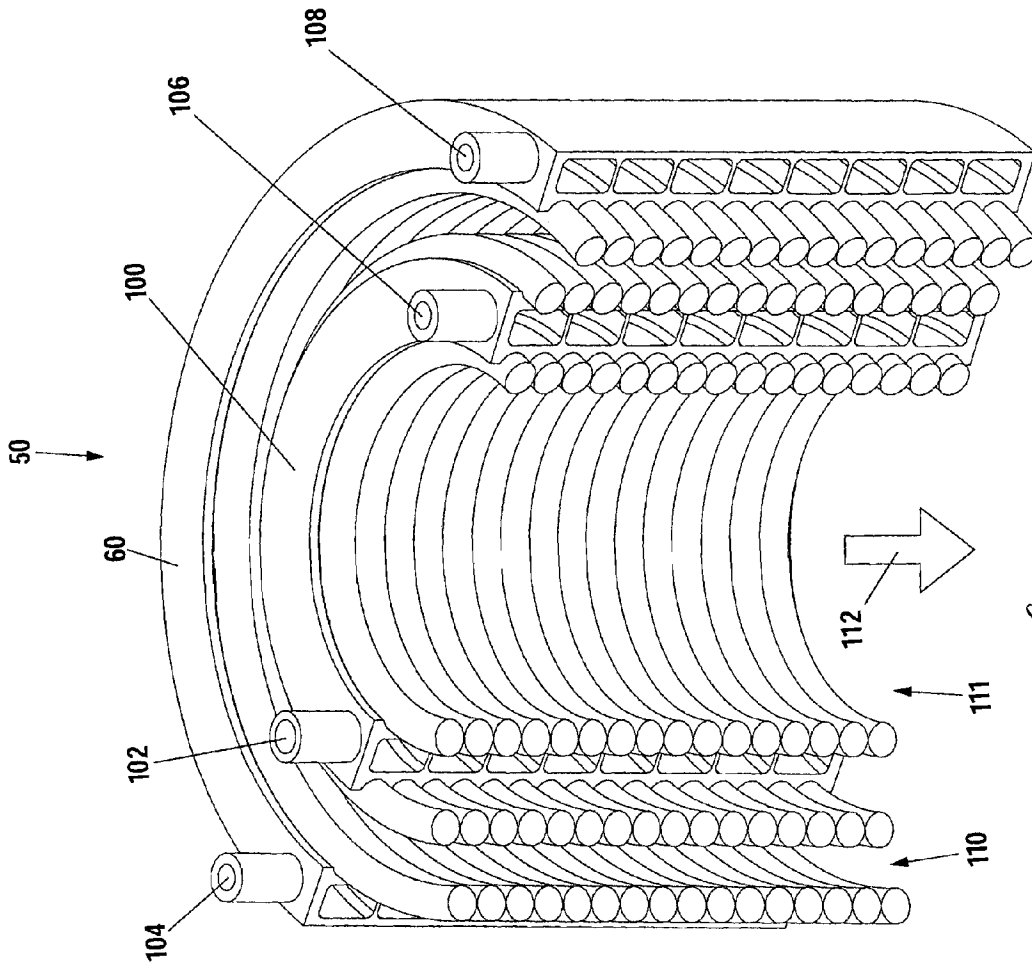
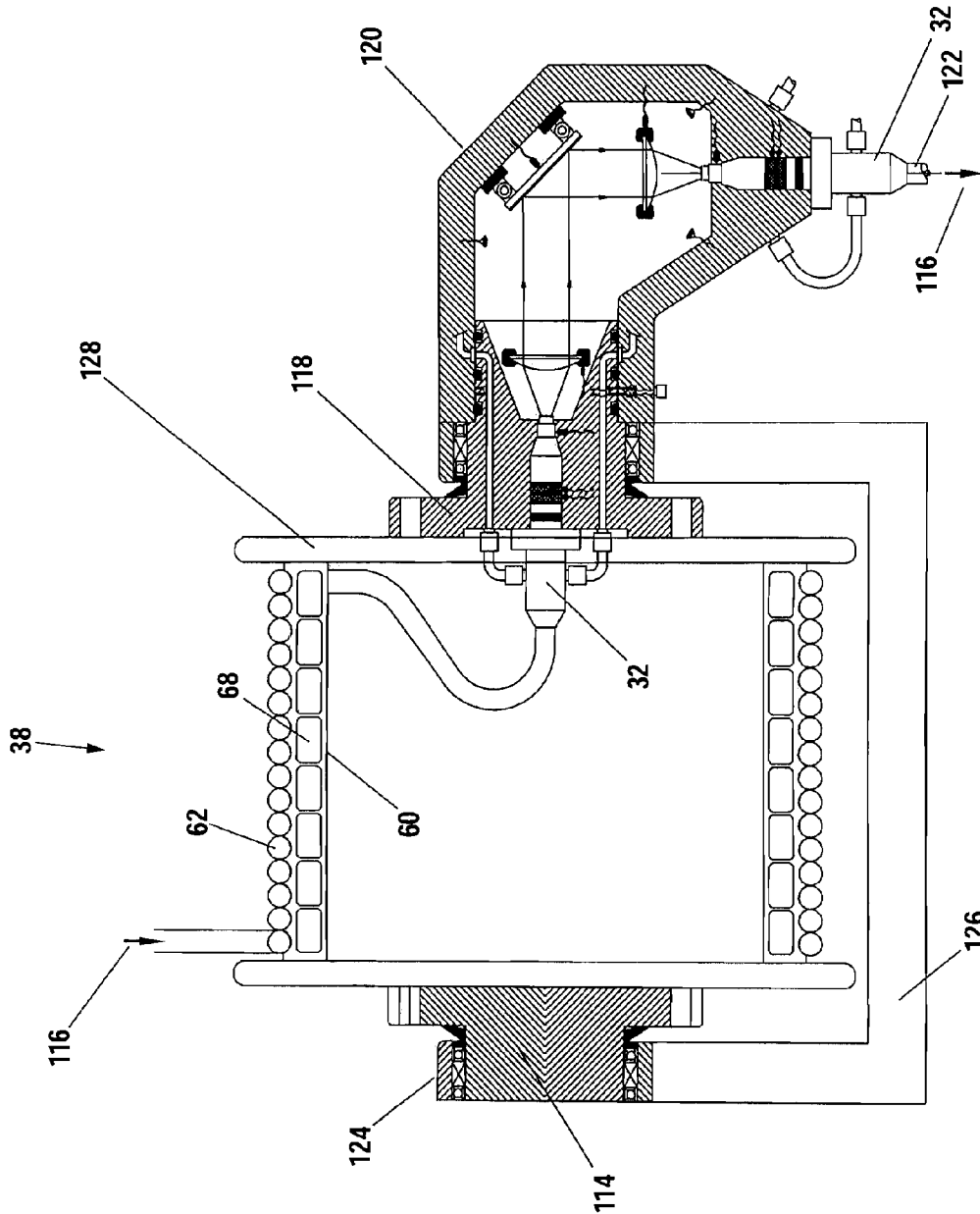

Fig. 59



*Fig. 5H*

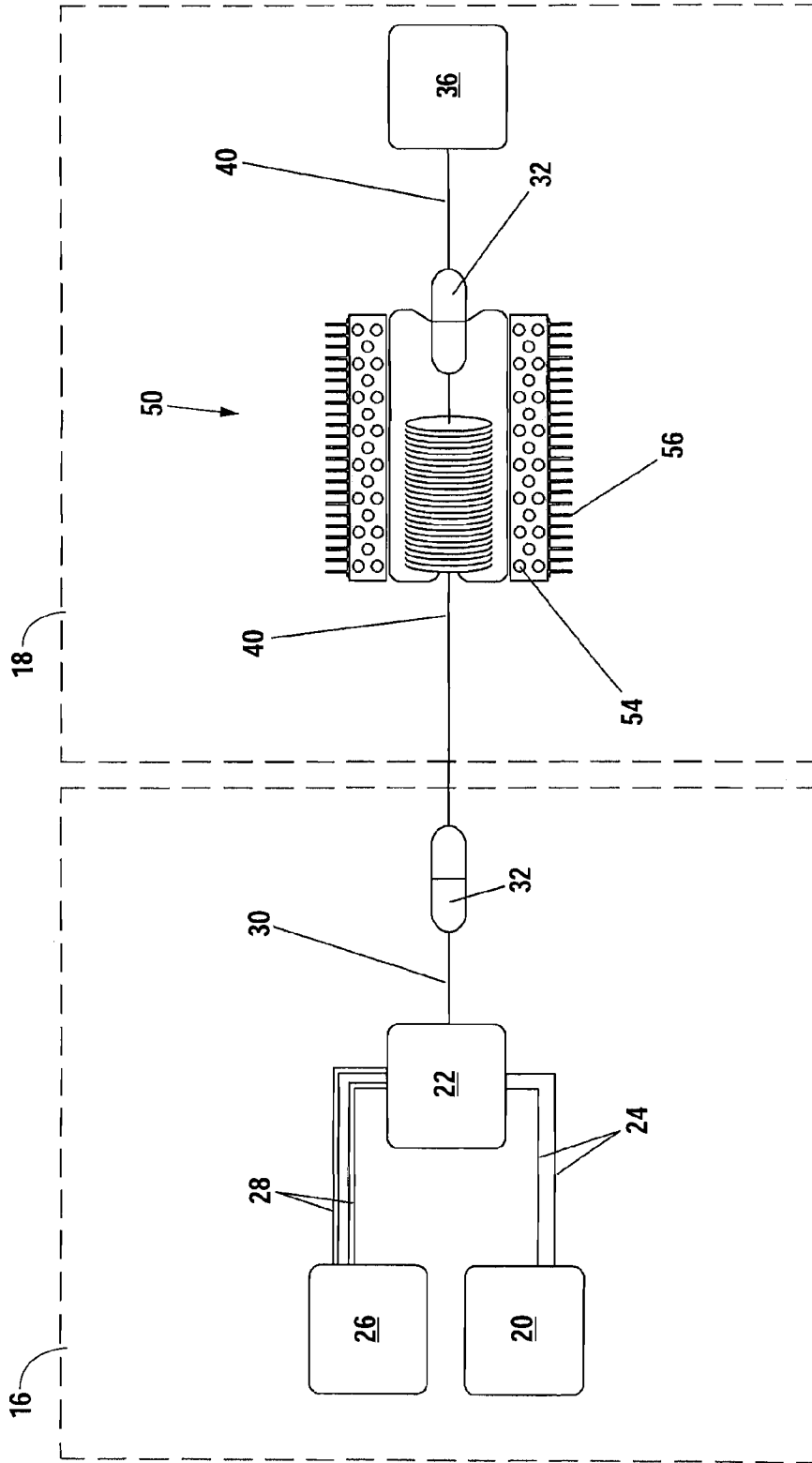

Fig. 6

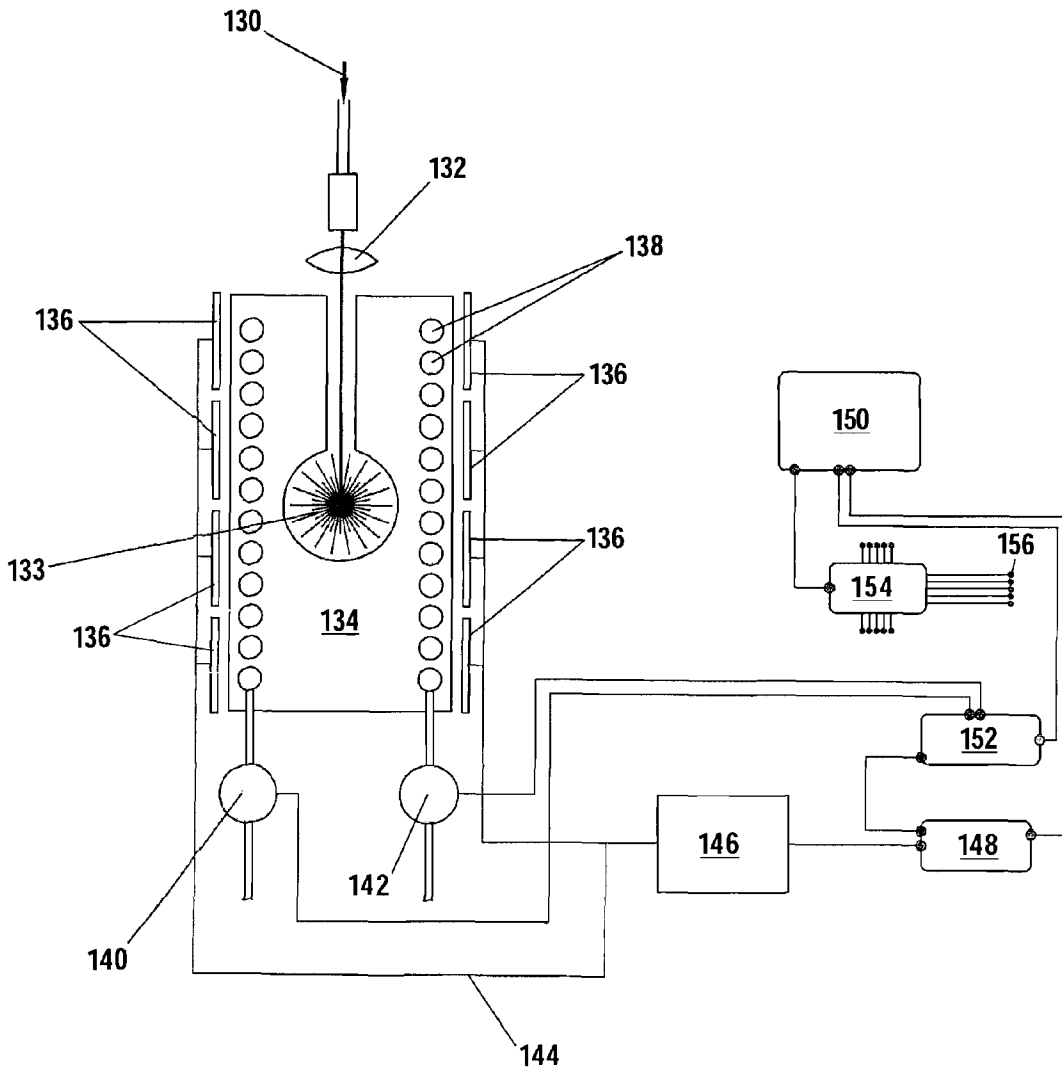

Fig. 7

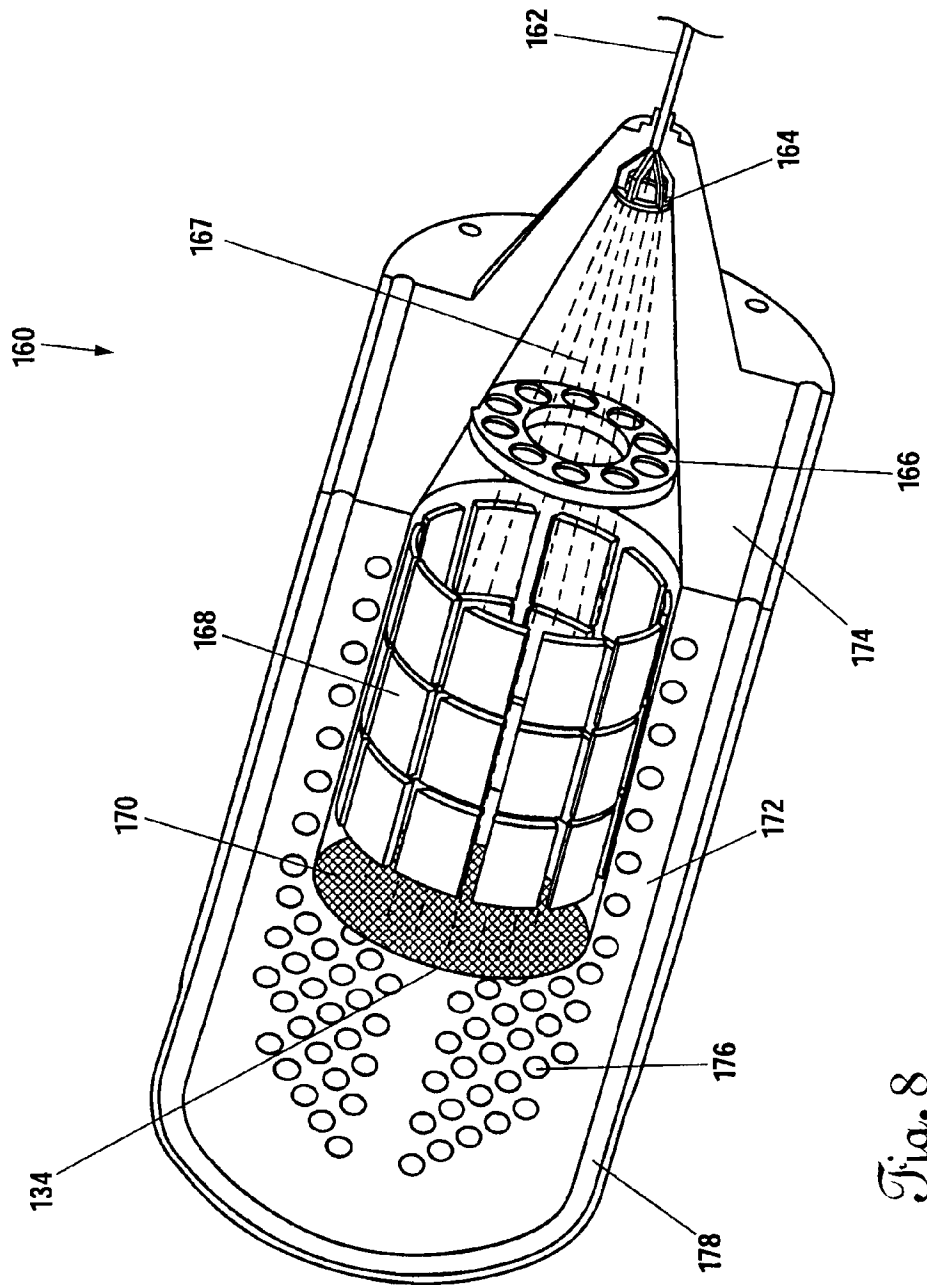

Fig. 8

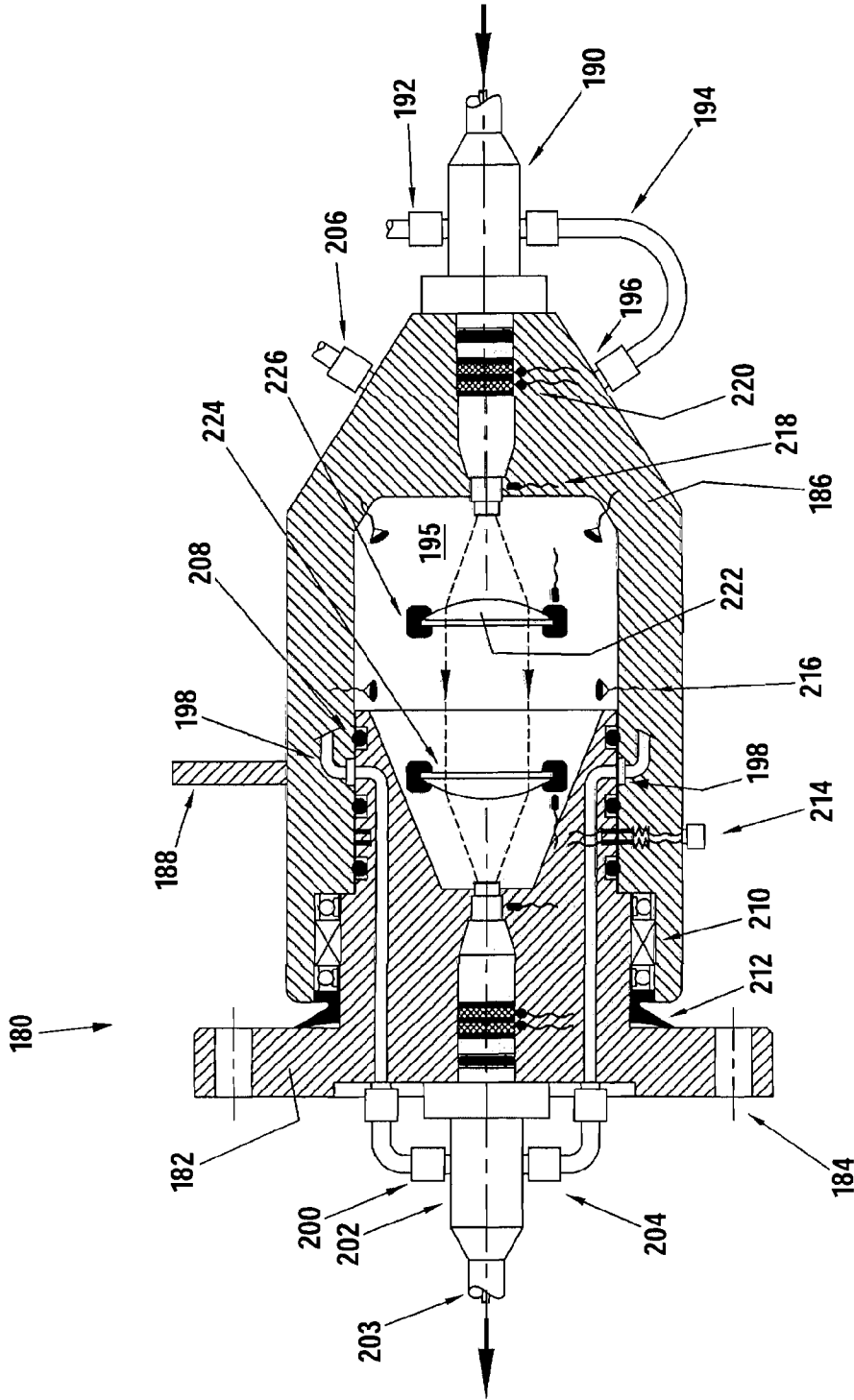

Fig. 9

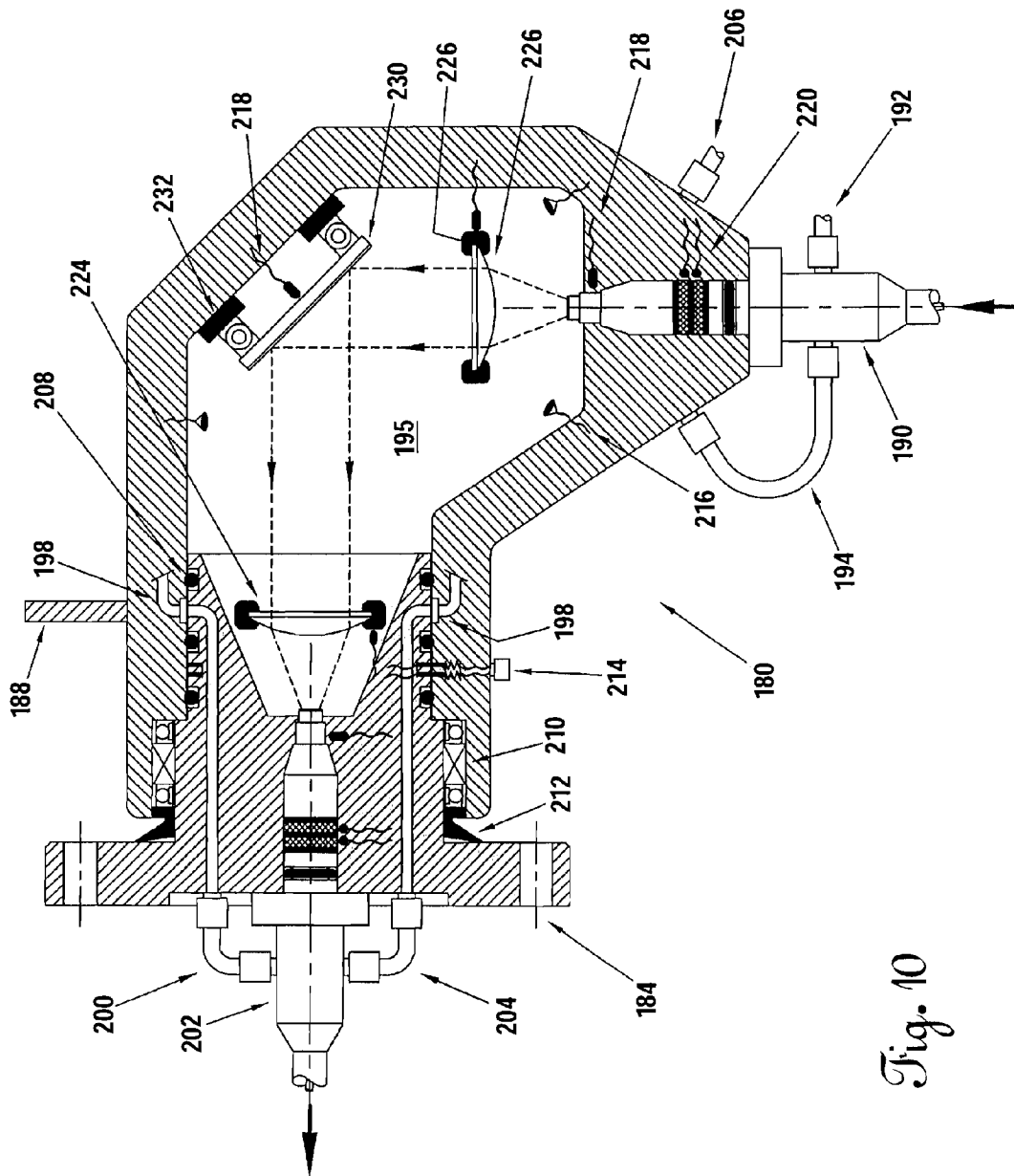

Fig. 10

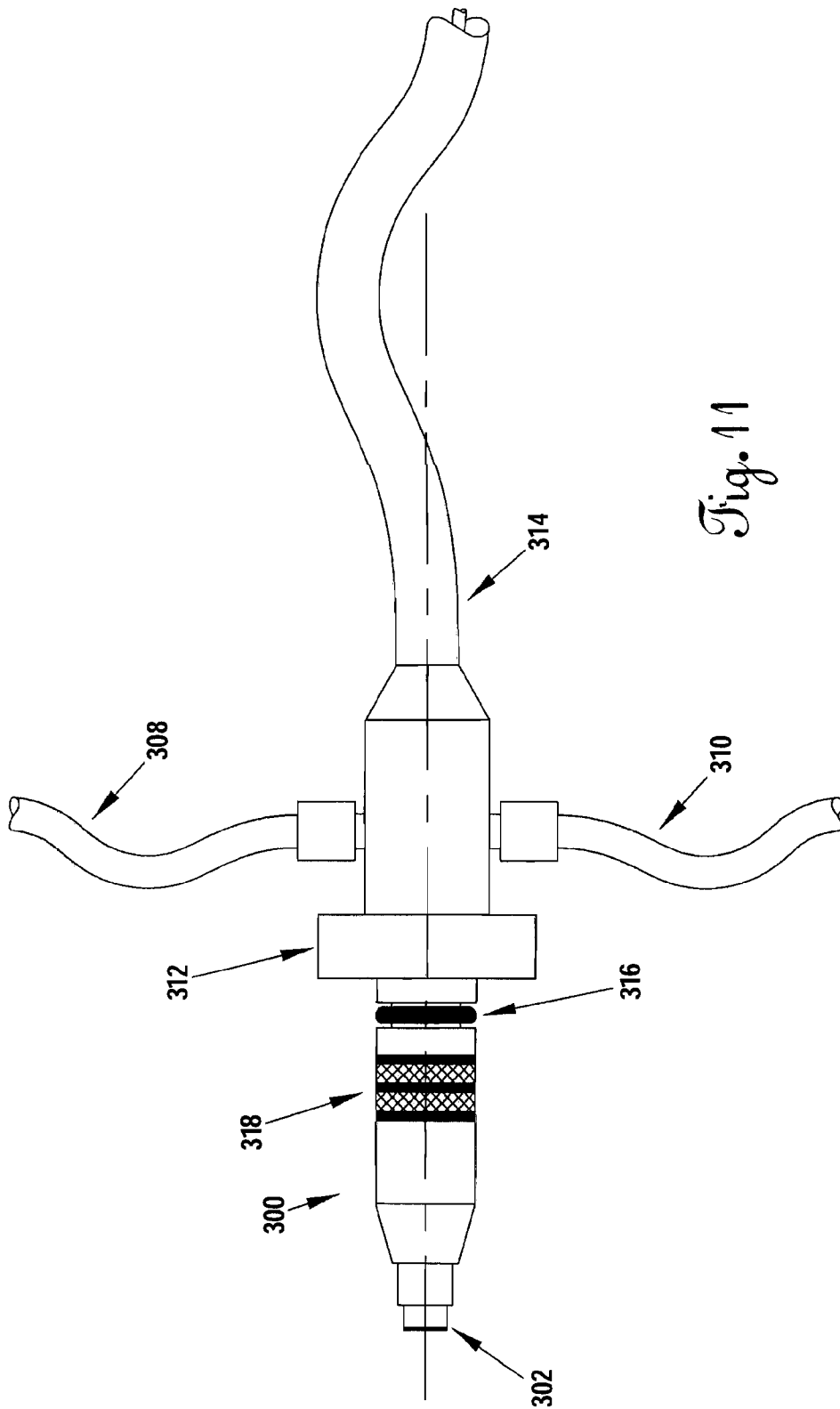

Fig. 11



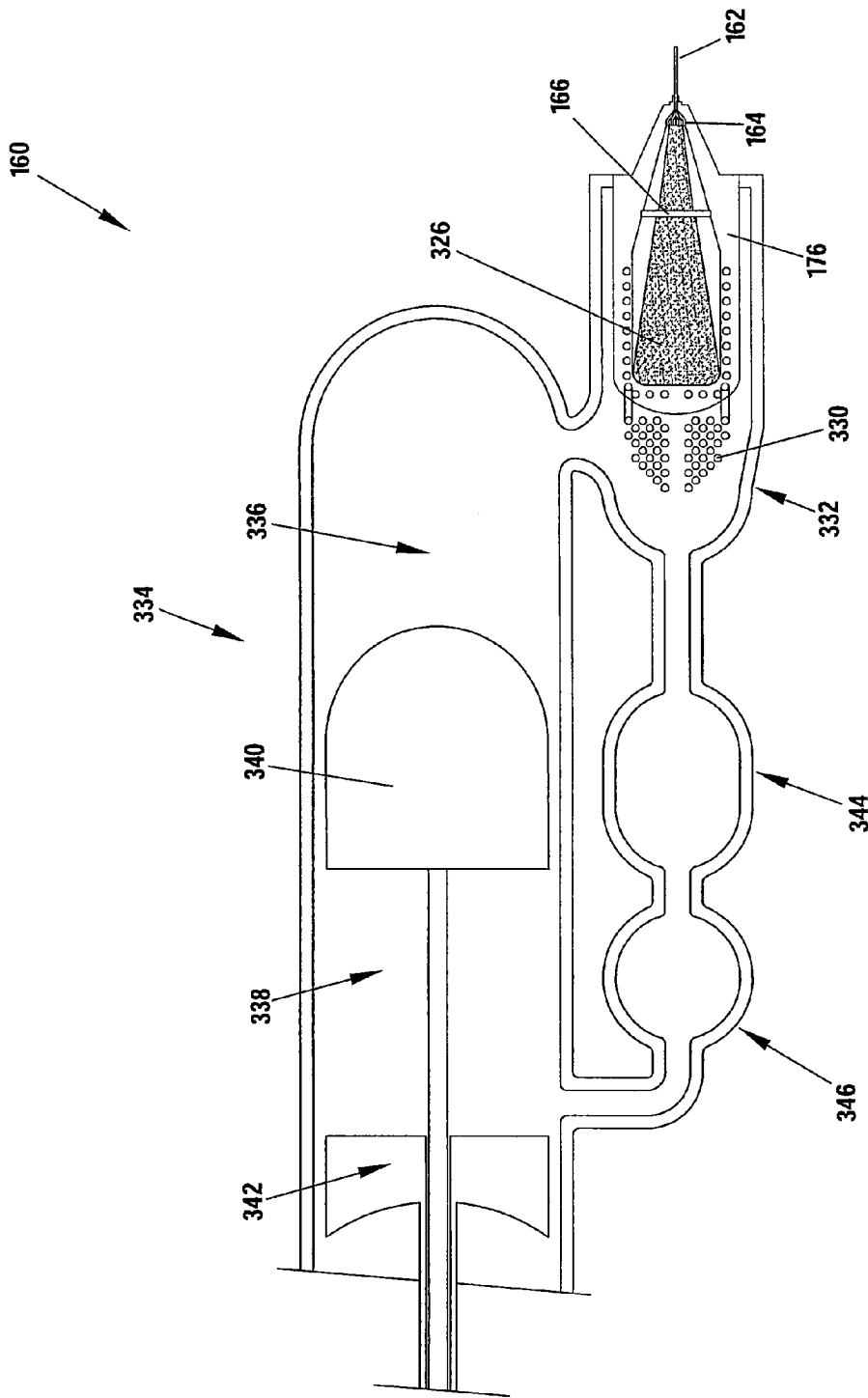

Fig. 12

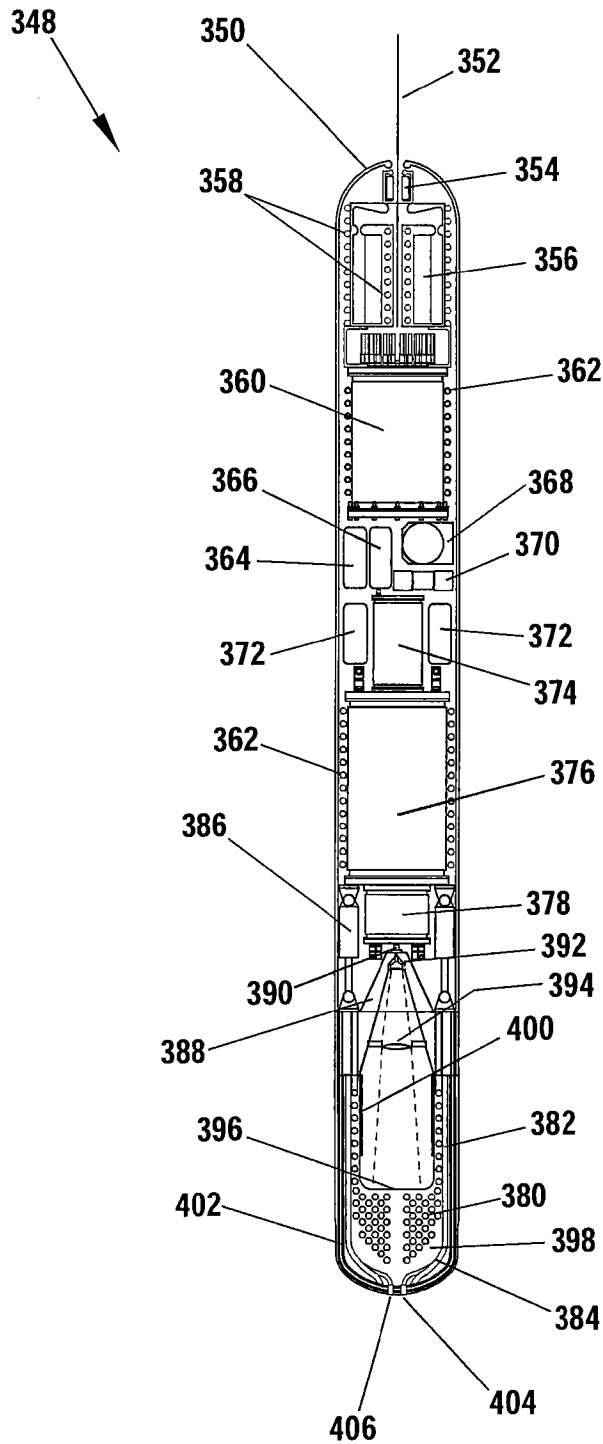

Fig. 13

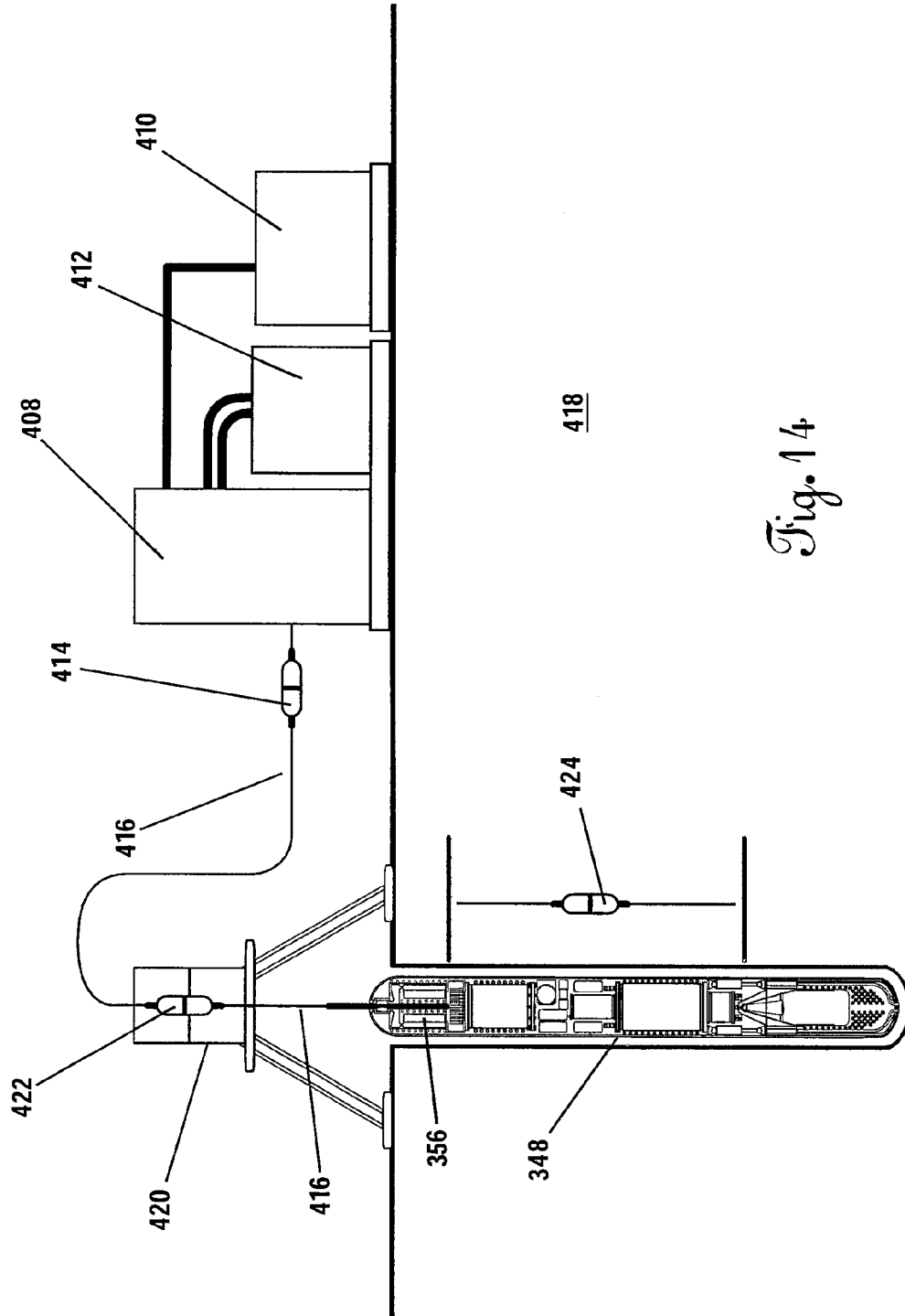

Fig. 14

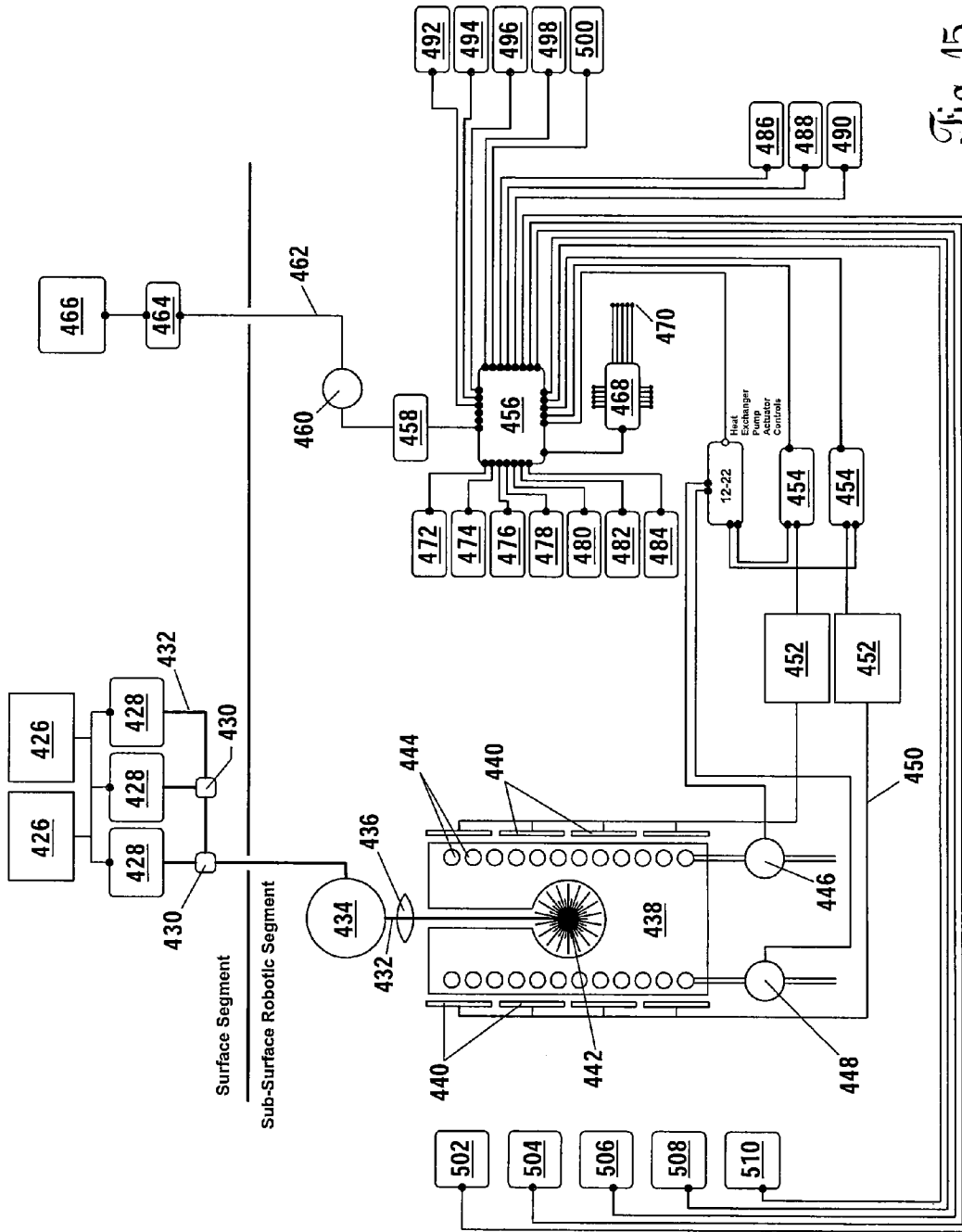

Fig. 15

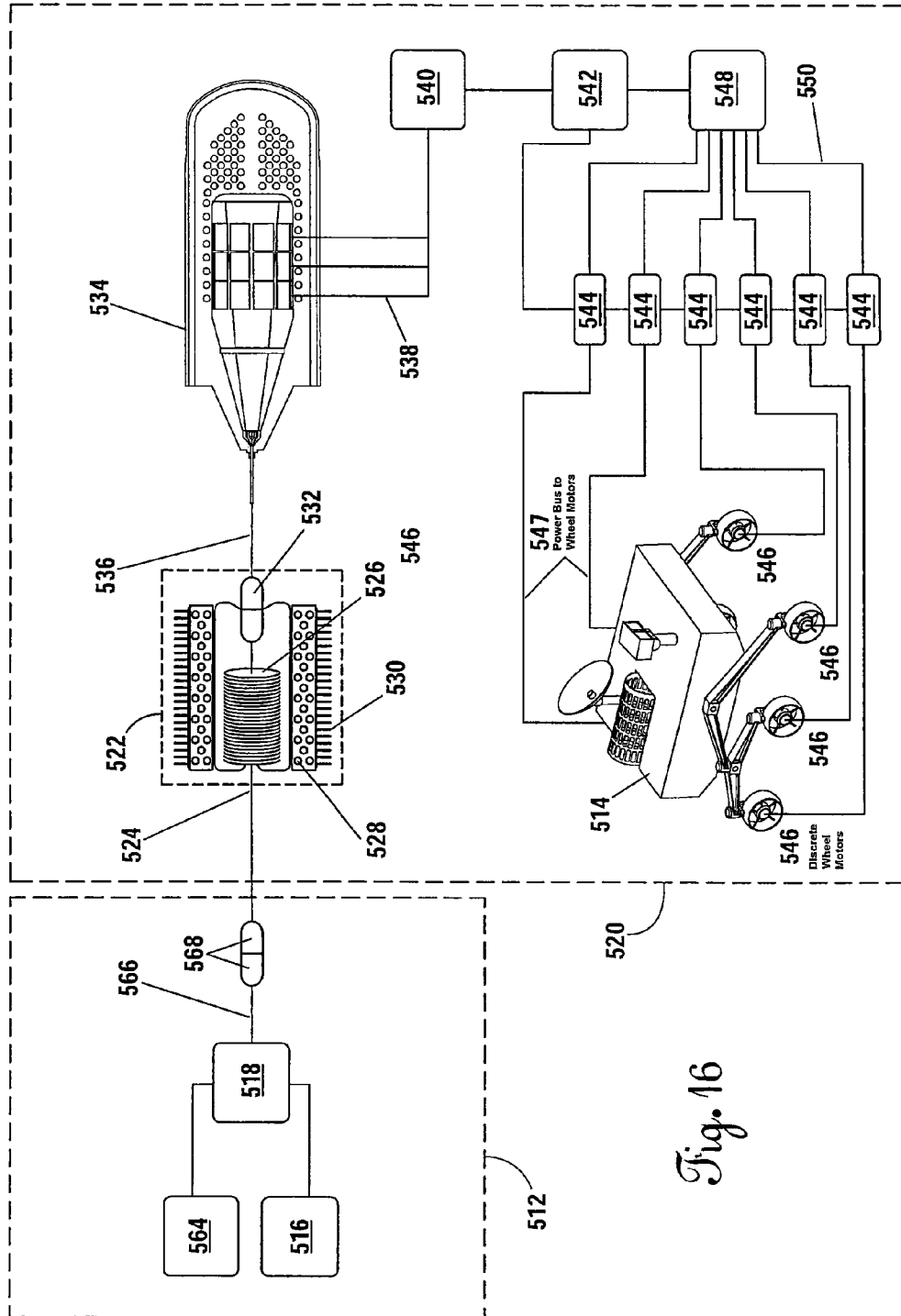

Fig. 16

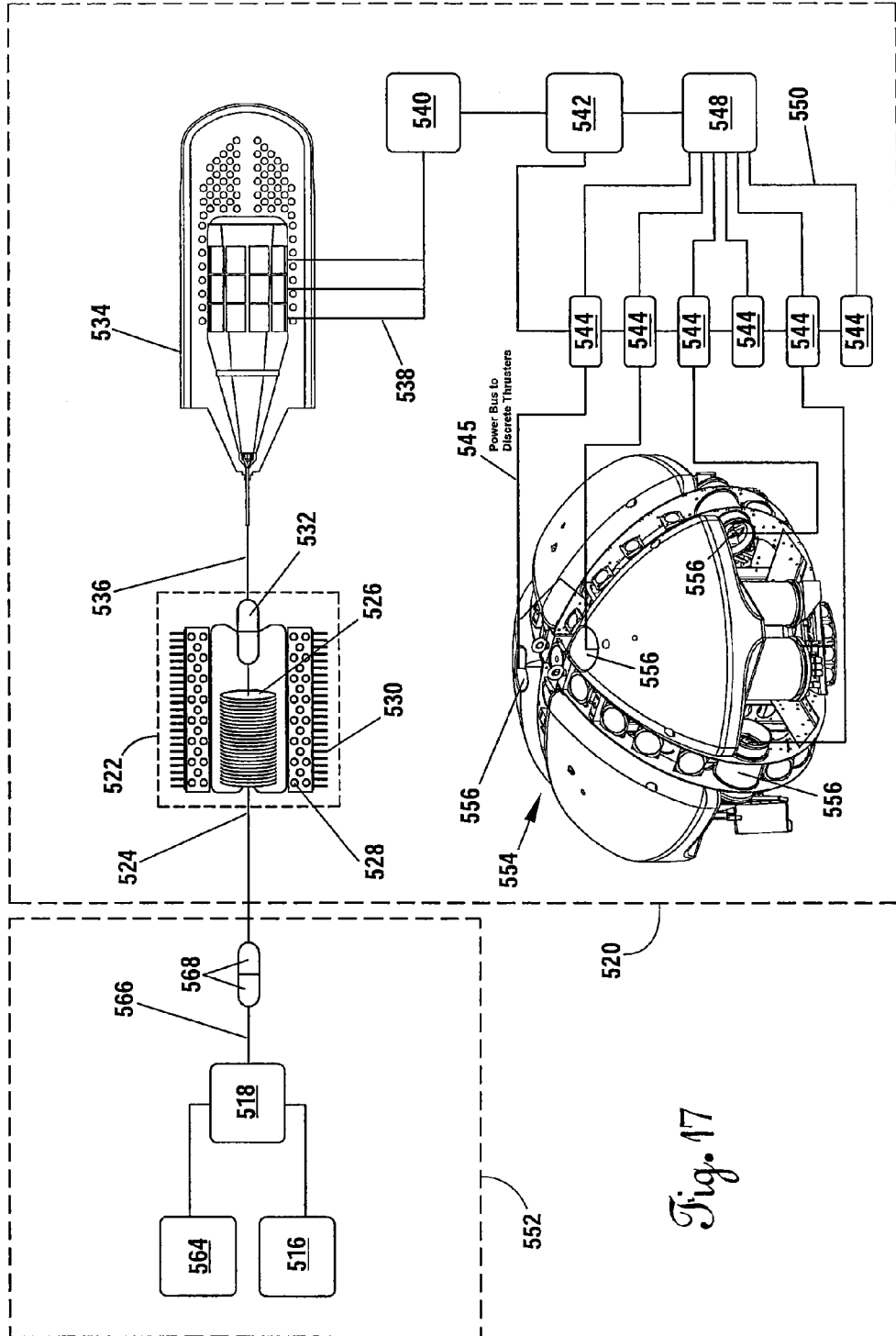

Fig. 17

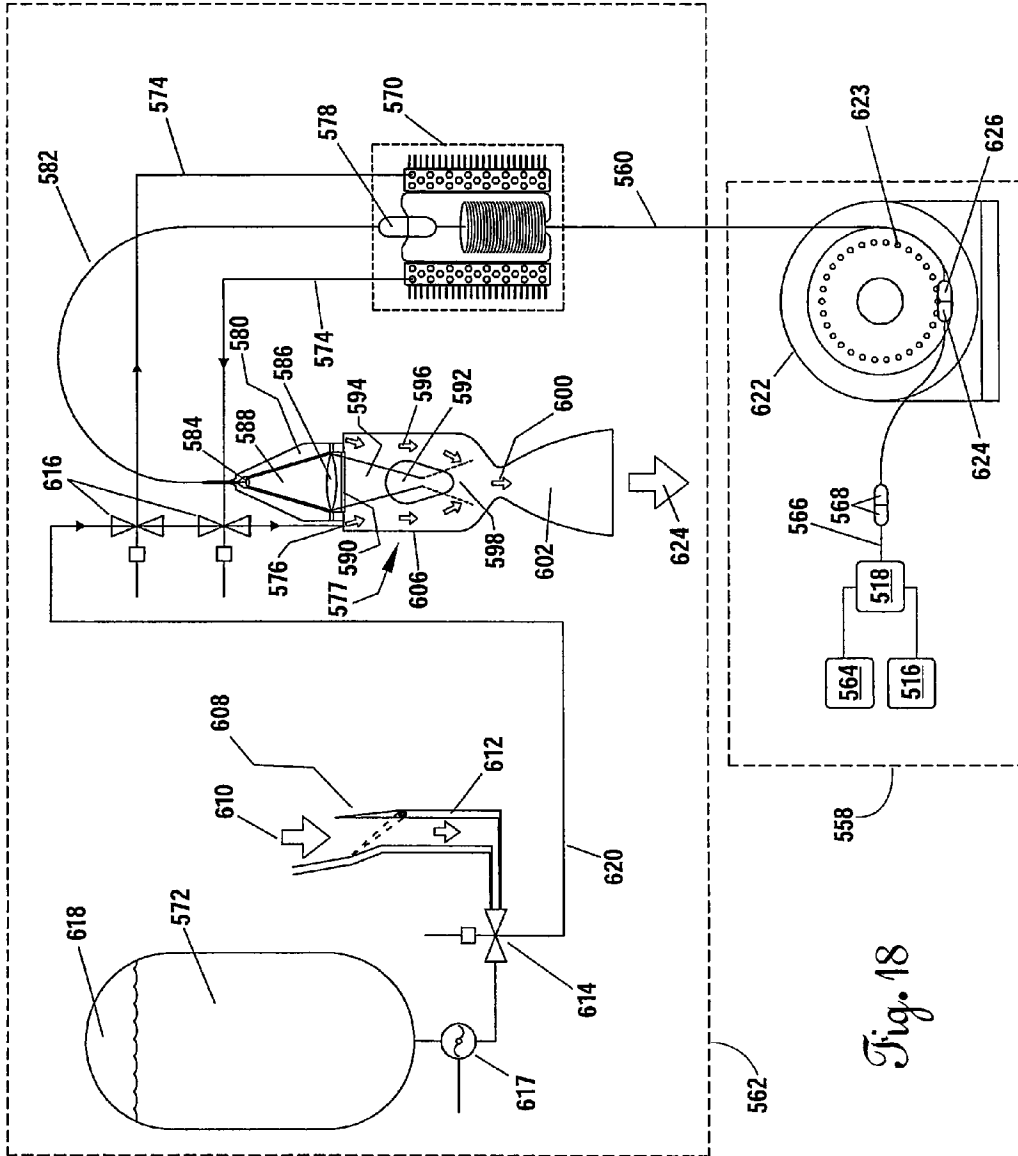
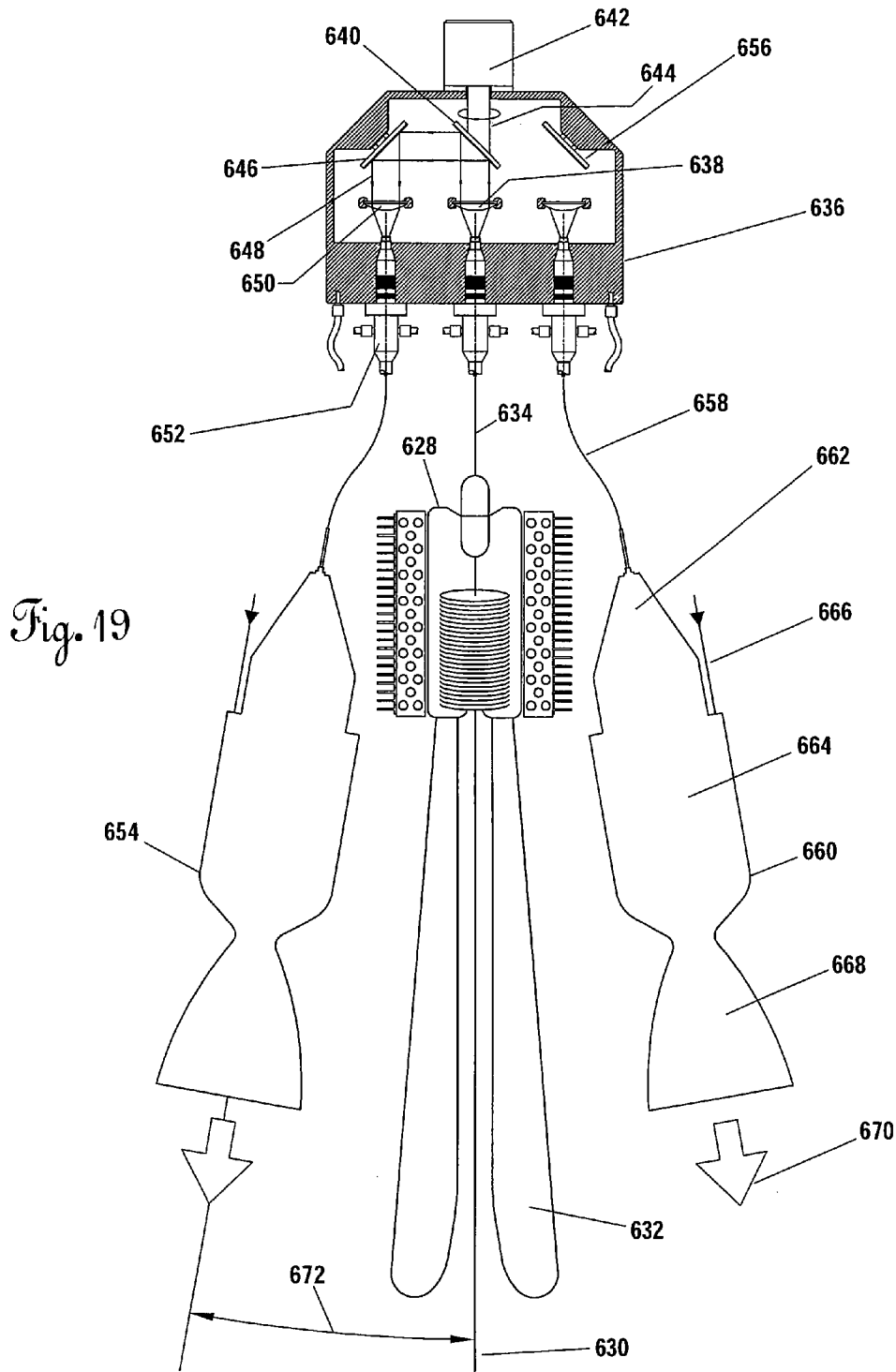

Fig. 18





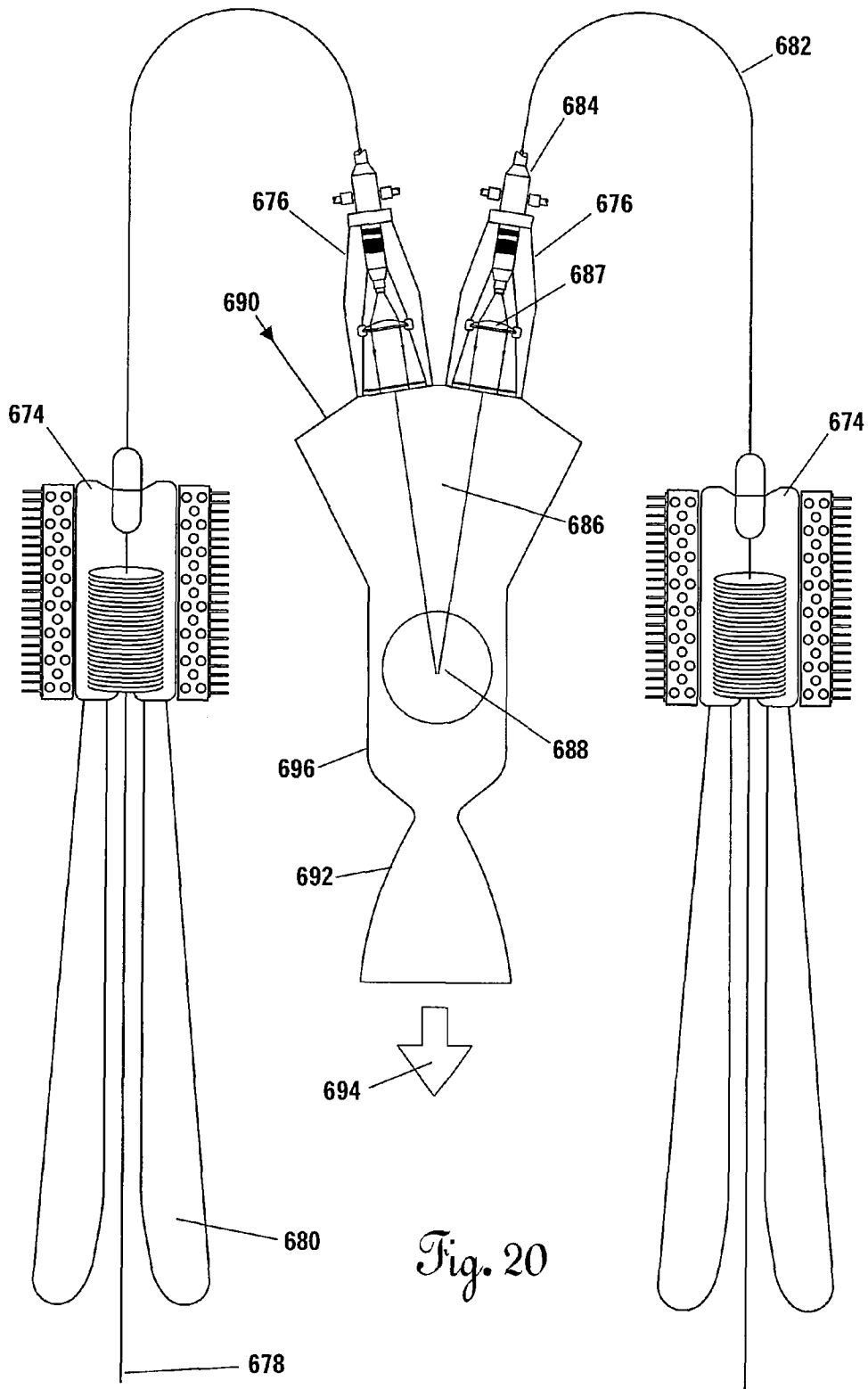

Fig. 20

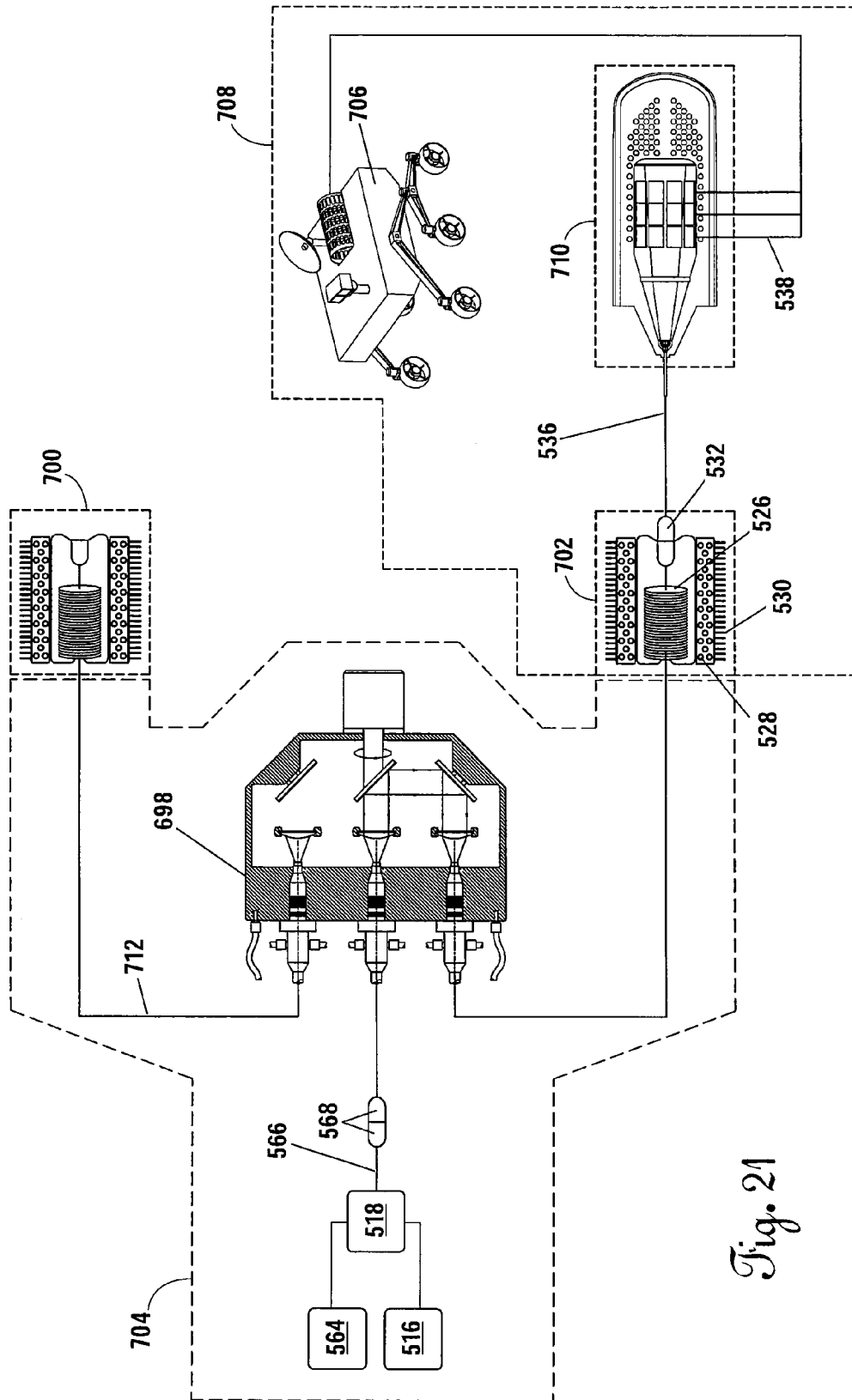

Fig. 21

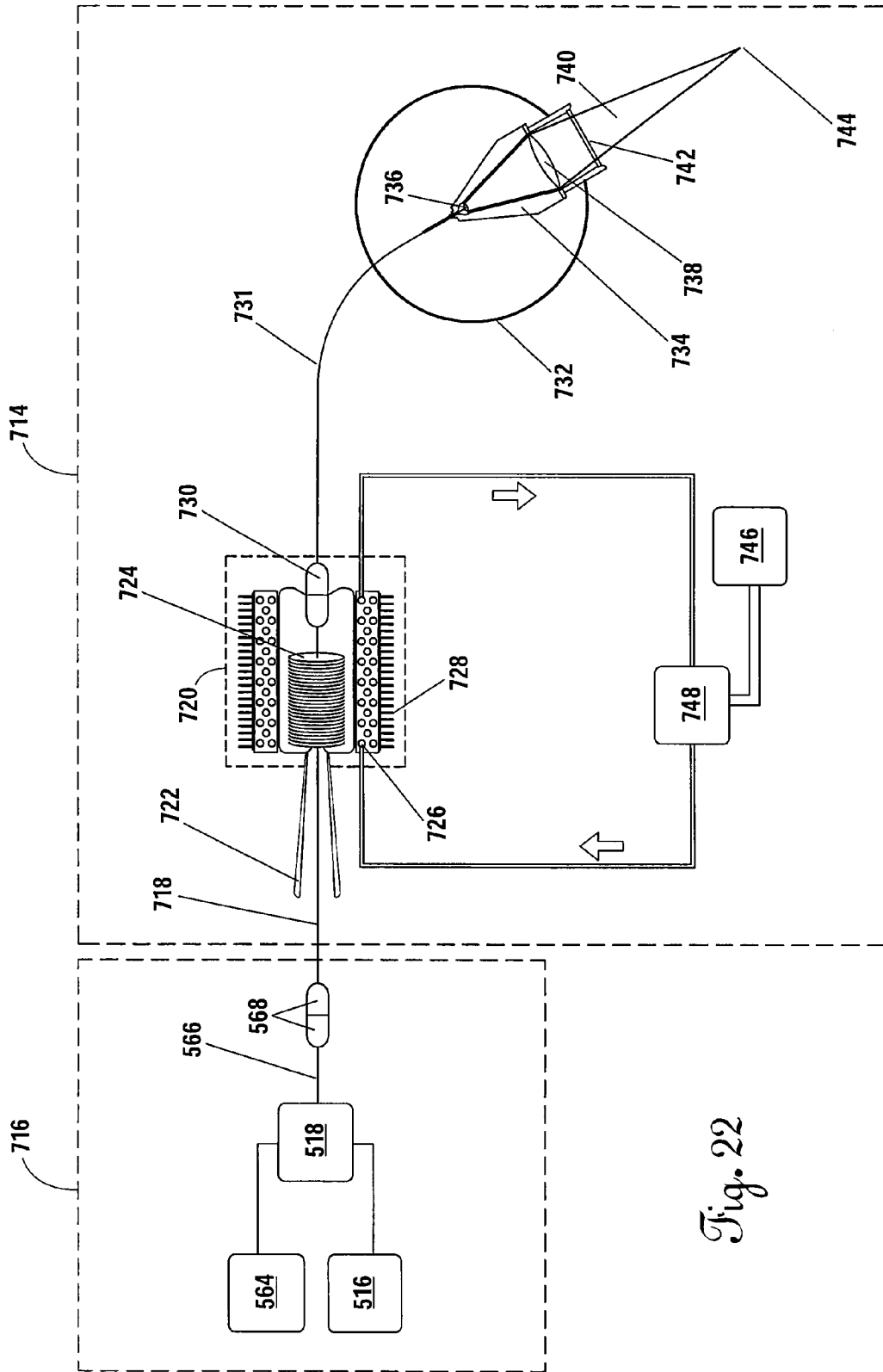

Fig. 22

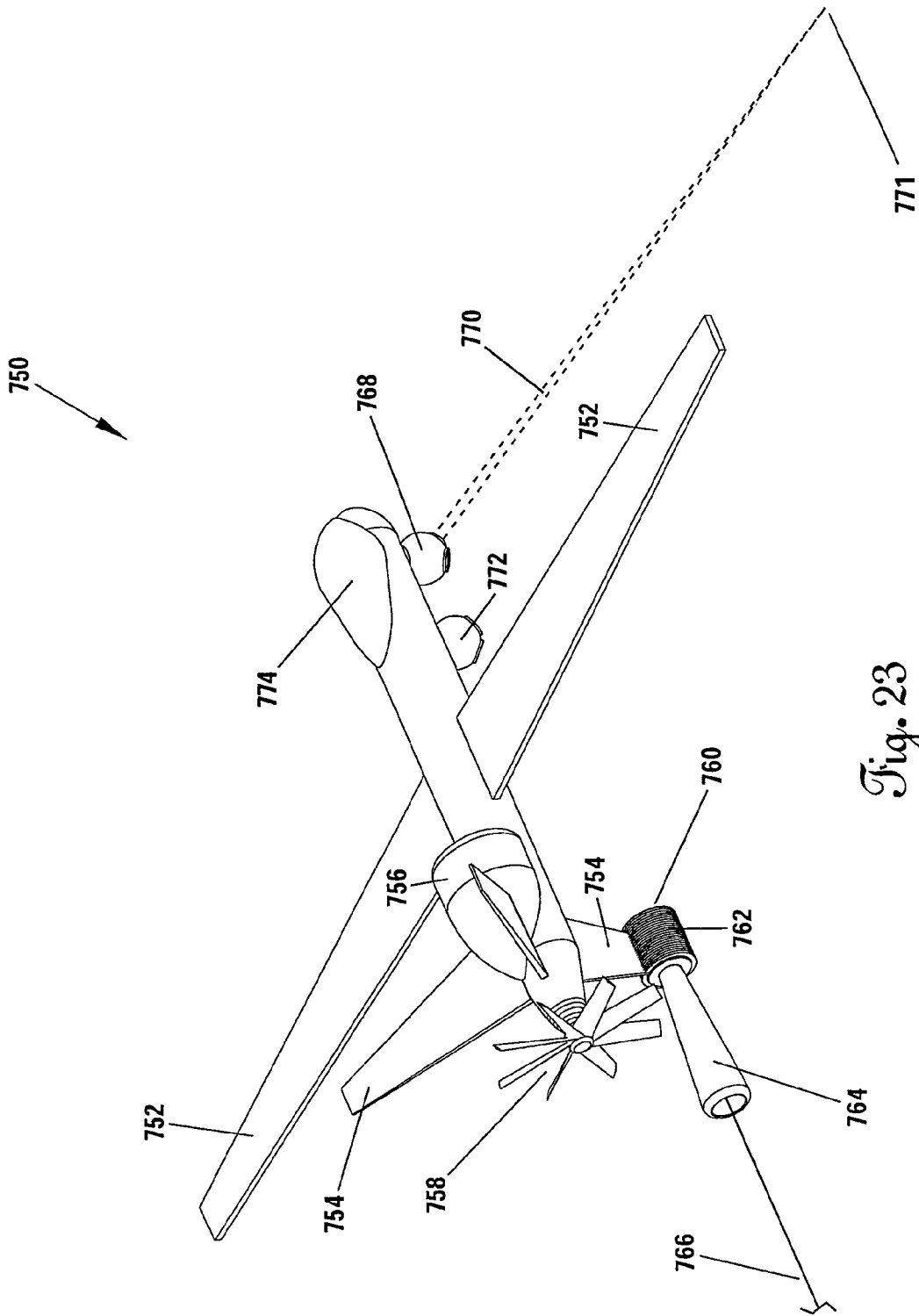

Fig. 23

## OPTICAL ENERGY TRANSFER AND CONVERSION SYSTEM

### CROSS REFERENCE TO RELATED APPLICATIONS

This original non-provisional application claims priority to and the benefit of U.S. provisional application Ser. No. 61/416,676, filed Nov. 23, 2010, which is incorporated by reference herein.

### STATEMENT REGARDING FEDERALLY SPONSORED RESEARCH OR DEVELOPMENT

This invention was made with Government support under Grant No. NNX10AE29G awarded by NASA. The Government has certain rights in the invention.

### BACKGROUND OF THE INVENTION

#### 1. Field of the Invention

The present invention relates to power systems. More specifically, the present invention is a system for the transfer of optical energy to a remote location and subsequent conversion of the transferred optical energy to another form of energy such as heat, electricity, or mechanical work.

#### 2. Description of the Related Art

It has been known in the telecommunications industry for several decades that light, or optical energy, can be sent down a relatively small diameter (e.g., twenty-five micron) glass optical fiber, modulated, and used to send large amounts of low-noise data or voice channels in a manner superior to traditional metal conductors. The range (i.e., distance) over which an un-boostered signal can be sent down such a glass fiber is controlled by a number of physical phenomena along with the geometry of the fiber and the materials used in its construction.

As light travels down the fiber, a portion of the injected energy is lost due to several mechanisms including Rayleigh scattering, OH absorption, imperfection loss, and infrared absorption. First, Rayleigh scattering is a function of the wavelength of the injected laser light and of the fiber material (frequently silica glass). Aside from selecting a low impedance fiber, the only way to reduce Rayleigh scattering is to select the wavelength of light that produces the least power loss per unit length of fiber. Second, OH absorption loss can be controlled or reduced by constructing fibers with ultra low OH content and avoiding wavelengths that coincide with wavelength-specific OH loss peaks. Third, imperfection loss can only be reduced by use of a fiber with minimal or no manufacturing imperfections. Often this is an issue of quality control of raw materials and manufacturing processes that draw the fiber slowly so as to not introduce imperfections. Finally, infrared absorption loss is a function of wavelength and material. Aside from material selection and improvement infrared loss can only be minimized by choosing an optical frequency that minimizes the losses.

In addition to the optical transmission loss mechanisms just described, there are other potential power loss mechanisms including: thermal damage to fiber at very high temperatures (whether externally or internally produced); non-linear effects such as SRS (stimulated Raman scattering), and also "self-focusing." Self-focusing has been predicted to potentially limit actual power delivery in a fiber to four or five megawatts regardless of fiber diameter, based on current theoretical assumptions and predictions. However, as with many previous theoretical predictions relating to estimates of power

and power density limitations for lasers, these estimates may also prove overly conservative in time.

FIG. 1A shows a plot of the theoretical composite attenuation limits for optical power transmission as a function of wavelength per kilometer of pure silica fiber. Other materials and fiber constructions (e.g., hollow, mirror-coated fiber) will have different attenuation characteristics. However, currently, pure silica fiber is the most readily available material to work with and obtain in long lengths (on the order of tens of kilometers). The composite attenuation is at a minimum at approximately 1540 to 1550 nanometers (nm) wavelength. This is due mainly because Rayleigh scattering decreases with increasing wavelength, but after a certain wavelength infrared losses begin to dominate, thus producing a distinct minimum attenuation, which is characteristic for pure silica. Other materials—and in particular, other doped optical materials—may exhibit different frequency response.

As a consequence of FIG. 1A, and for a wavelength of injected light between 1540 to 1550 nanometers with an initial injection power level of one megawatt, FIG. 1B shows the theoretical limiting optical power transmission as a function of the length of fiber, indicating that as far as one-hundred kilometers from the laser source, that an output power of approximately fifty kilowatts (kW) is achievable. This level of output power is significant, and sufficient to enable a host of novel applications.

FIG. 1B is a theoretical construct. Prior to the work of the inventors, fiber optics have been limited to low power data communications applications and limited "power over fiber" demonstrations at very low power levels (on the order of milliwatts) over standard telecommunications fiber. At the other end of the spectrum, industrial cutting lasers, many powered by fiber lasers, have used a very short (typically less than ten meters in length) "process" fiber for transfer of the laser energy to a local cutting head adjacent the laser and in the same building.

The concept of very high power transfer over very long distances had not been investigated. The inventors, in the fall of 2007, began investigating the concept of using optical fiber to send tens of kilowatts of optical energy to an ice penetrating robotic system as a means of enabling a test of a planetary ice-cap penetrating science vehicle for the investigation of the polar ice caps of Mars as well as the planetary ice cap of the Jovian moon Europa. The concept was driven by a need to achieve thermal power levels at the robotic system that were similar to those that would be developed by a systems nuclear auxiliary power (SNAP) thermal reactor (on the order of several tens of kilowatts) without the use of nuclear power, as the likely testing grounds for the system would be Antarctica, where present treaties prohibit the use of nuclear power.

In early July 2010, the inventors conducted a high power, long range laser power transfer test that utilized a twenty-kilowatt infrared (1070 nanometer) fiber laser wherein power levels from zero to ten kilowatts were incrementally injected into a 1050-meter long coil of multi-mode, step index, pure silica core, fluoride doped cladded with polyimide coating (400  $\mu$ m core, 440  $\mu$ m cladding, 480  $\mu$ m coating diameters). The fiber numerical aperture (NA) was 0.22.

FIG. 2 shows the results of that test, which compare favorably with the theoretical attenuation limits shown in FIG. 1A. The fiber was coiled into a one-meter diameter spool which was water cooled in a static flow bath, the temperature of which was monitored. The power was ramped up from one hundred watts to ten kilowatts over an approximately one-hour period. After five minutes at ten kilowatts, the peak temperature of the fiber was fifteen degrees Celsius above ambient as monitored using a forward looking infrared

(FLIR) camera. This test pushed new boundaries in terms of the injected power levels sent through an optical fiber but also contradicted traditional thinking in the high power process laser industry that the power would have been completely dissipated by the large number (334) of bends to the fiber in the process of fabricating the coil.

With this as a background, we now discuss some important recent factors that enable practical implementation of the systems that will subsequently be described below. FIG. 3A shows a plot of raw industrial laser continuous output in kilowatts versus year for a single mode fiber laser. These were laboratory curiosities in the early 1990s. In 2009, however, an output level of ten kilowatts was achieved for a 1070 nm industrial fiber laser. It is important to note that with fiber lasers it is possible to combine several single mode lasers by injecting their individual beams into a multimode fiber. To date, multimode fiber lasers have achieved power levels of fifty to sixty kilowatts through one multimode fiber, operating over a short distance of process fiber (less than ten meters) between the laser and its output optics.

An equally important measure of progress is that of power density, expressed in megawatts per square centimeter (MW/cm<sup>2</sup>). FIG. 3B plots power density in MW/cm<sup>2</sup> since 1994. A more practical means of understanding what this graph means is presented in FIG. 3C, in which the LOG of power density is plotted. This plot indicates that, at the current pace of development, which has been sustained since 1994, the power density will increase by an order of magnitude every six years.

Finally, FIG. 3D shows the theoretical power that can be transferred through a fiber optic carrier as a function of fiber core diameter (in microns) using optical power densities achieved in 2009. A three-hundred fifty micron core fiber is capable, today, of carrying a megawatt of optical power. FIG. 1B, as previously discussed, shows the output power that could be expected as a function of distance from the laser for a contiguous fiber.

The data presented in the figures referenced supra presage the possibility of sending enormous amounts of optical power over very long distances using very small diameter, lightweight fibers and converting that optical power to a more usable form of energy. Importantly, because the fiber is carrying the power, it will not be attenuated by the environment surrounding the fiber nor by a situation wherein the consumer of the power is not in visible line-of-sight of the source laser. This has profound implications on the development of many systems heretofore not considered possible.

FIG. 4 shows the very basic premise of the transfer of coherent high power laser radiation between a laser source 22 and a remote system 36 in which a base power source 20 (e.g., a nuclear power plant, a fossil fueled power plant, a large diesel generator, a very large array of solar cells, etc.) is used to provide electrical power to the high power fiber laser 22 via electrical conductors 24. Currently, the best fiber lasers are on the order of thirty-five percent power conversion efficiency (i.e., for every ten watts of raw electrical power, three-and-a-half watts of coherent laser radiation can be produced). Because of this, the laser 22 dissipates a substantial thermal heat load. To counteract this, a cooling system 26 and heat transfer system 28 is used to maintain thermal control at the laser. All of this infrastructure takes up volume, has significant mass, and consumes large amounts of power. It is therefore best located in some fixed ground facility or a large mobile facility (e.g., a ship). From the laser 22, a high energy process fiber 30 leads to a high power optical coupler 32, to which any number of devices can be connected. Traditionally, the only items to be connected to this category of multi-

kilowatt laser are focusing optics for use in materials handling—e.g., cutting metal plates or fabric. Because of this, the length of the process fiber 30, 34 are generally quite short—on the order of five to ten meters.

The present invention relates to a system and apparatus that enables the transmission and effective end-use of very large amounts of optical power (e.g., kilowatts to tens of megawatts) over relatively long distances (e.g., from a kilometer to as much as one hundred kilometers or more) to fixed, movable, or mobile platforms operating on the ground, undersea, under ice, in the air, in space, and on other planets. The invention is usable in non-line-of-sight conditions, which allows it to directly bypass severe problems that have plagued efforts to utilize laser power beaming over large distances through the atmosphere, underwater, and over terrain where the receiver is not within view of the optical power source. The present invention permits first kilowatt and then ultimately multi-megawatt optical power injection and utilization over the length of a long deployed fiber.

#### BRIEF SUMMARY OF THE INVENTION

The invention is an optical power transfer system comprising a fiber spooler and an electrical power extraction subsystem connected to the spooler with an optical waveguide. Optical energy is generated at and transferred from a base station through fiber wrapped around the spooler, and ultimately to the power extraction system at a remote mobility platform for conversion to another form of energy. An alternative embodiment of the invention further comprises a fiber optic rotary joint mechanically connected to the fiber spooler, with the fiber optic rotary joint positioned optically between the spooler and the power extraction system.

#### BRIEF DESCRIPTION OF THE SEVERAL VIEWS OF THE DRAWINGS

FIG. 1A shows a plot of the theoretical composite attenuation limits for optical power transmission as a function of wavelength per kilometer of pure silica fiber.

FIG. 1B shows a plot of the theoretical limiting optical power transmission as a function of the length of fiber.

FIG. 2 is a plot of a high power, long range laser power transfer test.

FIG. 3A shows a plot of raw industrial laser continuous output versus year for a single mode fiber laser.

FIG. 3B plots power density in MW/cm<sup>2</sup> since 1994.

FIG. 3C plots the log of the power density of FIG. 3B for a single mode fiber laser.

FIG. 3D shows a plot of the present optical power transmission as a function of fiber core diameter.

FIG. 4 shows the basic premise of high power laser radiation transfer between a plant fiber laser system and a remote system.

FIG. 5A shows a first variation on the optical, long-range power transfer invention of the present invention.

FIG. 5B shows a second variation of the invention incorporating an axial precision-wound spooler.

FIG. 5C is a detailed example of an embodiment involving a single exterior mandrel, precision-wound high energy optical fiber spooler.

FIG. 5D shows a cut-away detail of the exterior wrapped mandrel of FIG. 5C.

FIG. 5E is a top isometric view of the same external fiber spooler and protective shell system described with reference to FIG. 5C.

FIG. 5F is a variation on the axial high power fiber spooler **50** in which the mandrel **60** defines winding grooves **86** on the interior surface.

FIG. 5G shows yet another variation on the high power axial fiber spooler **50**.

FIG. 5H shows a cross sectional detail of an embodiment of a drum-type high energy fiber spooler such as shown in FIG. 5A.

FIG. 6 depicts an alternative embodiment of the system in which the fiber spooler is carried onboard a remote system or mobile system.

FIG. 7 is a system diagram of the electrical power extraction subsystem of the system.

FIG. 8 is a isometric view of mobility system power head **160** implementing the invention.

FIG. 9 is a sectional view of an embodiment of a fiber optic rotary joint (FORJ) that can be used with the present invention.

FIG. 10 is a sectional view of another embodiment of a FORJ that can be used with the present invention.

FIG. 11 shows an exemplary laser connector suitable for use in the present invention.

FIG. 12 shows an embodiment of the system in use with Beta-type Stirling engine.

FIG. 13 shows an embodiment of the system in use with an autonomous underwater vehicle.

FIG. 14 depicts a mission configuration for the autonomous vehicle shown in FIG. 13.

FIG. 15 shows a system schematic for an autonomous cryobot.

FIG. 16 shows an embodiment in use with an exploration and science rover.

FIG. 17 shows another embodiment in use with an underwater vehicle.

FIG. 18 shows an embodiment in use with a launch vehicle.

FIG. 19 shows an embodiment having a central spooler in use with multiple thrusters.

FIG. 20 shows an alternative arrangement of the system of FIG. 19.

FIG. 21 shows an embodiment using a rotary beam switch with multiple spoolers.

FIGS. 22-23 shows an embodiment in use with an unmanned aerial system.

#### DETAILED DESCRIPTION OF THE INVENTION

Referring to FIG. 4, in the present invention, the length of the output fiber **34** is desirably a long distance—from a few kilometers to upwards of one hundred kilometers or more—and used for the purpose of providing, specifically, optical energy to a remote system **36** that consumes the power in a variety of ways for the purposes of mobility, propulsion, raw thermal power utilization, electrical power conversion, mechanical power extraction or for the purpose of using the laser energy itself in a focused beam.

Referring now to FIG. 4 and FIG. 5A, one could conceive of setting up such a system whereby a truck is used to lay fiber **34** from the plant-based (fixed) fiber laser system **16** to a fixed actuator **36** that uses the energy at some significant distance from the laser source **22**. In general, this will have very limited utility because it would be, under most conditions, equally possible to use a local power source at the location of the remote system **36** and not pay the price for the power lost along the fiber **34**. In other words, traditional electric power infrastructure will be more cost competitive than deploying a fixed infrastructure that depends upon power sent to it via an optical waveguide or fiber. This is not the case, however,

when we wish to consider mobile systems that perform a variety of tasks and where it is entirely disadvantageous, if not impossible, for the mobile system to carry all of the extensive infrastructure needed to generate its own power.

FIG. 5A shows a first embodiment on the present invention in which the base station **16** comprises a servo-controlled large-diameter drum spooler **38** fabricated from a high thermal conductivity material (e.g., beryllium oxide, copper, or aluminum) to facilitate cooling. A large length (kilometers) of fiber **40** is rolled onto this spooler **38** prior to a mission in which the remote system **18** (e.g., a vehicle) is sent forth to do work. As the vehicle leaves the base—for example, a large sea going ship, where the vehicle is an underwater vehicle such as an autonomous underwater vehicle (AUV) or remotely operated vehicle (ROV)—the drum spooler **38** will rotate and feed fiber **40** out to the vehicle. This approach will work well in the restricted situation where there are no obstacles in the path of the vehicle that might serve to trap the fiber **40** and prevent return of the vehicle. For example, it would work well for sea-going operations and could potentially be made to work, using bare fiber, for aerial operations where the base station **16** was carried by a large lighter-than-air airship and the remote vehicle **18** was an unmanned aerial vehicle (UAV) connected to the airship via a bare optical fiber for weight reduction.

The drum spooler **38** has several important characteristics, including an actively-cooled high power laser coupler **42** that will permit easy maintenance of the drum spooler **38**. Because of the high power levels involved, the spooler **38** must have an active cooling system **44**. The reason for this is that not only will power be dissipated along the length of the fiber **40** by the normal Rayleigh scattering and infrared radiation, but it is also compounded by additional losses associated with the bend radius of the fiber **40**. Bending losses are a function of the fiber construction (e.g., core, cladding, coating styles, and refractive indexes), the fiber diameter, the bending diameter, and the laser power conditions entering the bending section. Bending losses will be controlled by selecting a combination of fiber type, size, and construction along with an appropriate spooler diameter for the specific application. The cooling system **44** can consist of any traditional means for transferring excess heat away from the spooler **38**, including, but not limited to, heat exchangers, convective, conductive, and radiative cooling mechanisms (see FIGS. 5C-5H).

Importantly, the drum spooler **38** is mechanically connected to a high-energy fiber optic rotary joint **46**, as will be described in more detail with reference to FIGS. 9-10, in which a fixed fiber that transfers optical power at high levels through coupler **42** is channeled to the core of the spooler **38** which rotates freely relative to the fixed coupler **42**. This is required to avoid unacceptable twisting that would ultimately lead to failure of the fiber **40**. The design of a viable ultra-high-power fiber optic rotary joint is a complicated undertaking.

The drum spooler **38** is desirably of large diameter to limit power loss associated with bending of the fiber to form the cylindrical (or other similar object of revolution) spool. Power loss associated with bending can be minimized by using a large bend radius, using smaller diameter fiber, and fiber with a high numerical aperture (NA). Preferably, the diameter of the spooler **38** needs to be large enough that the power losses due to the bending of the fiber do not heat the fiber excessively for the given cooling conditions and they are an acceptable percentage of the total power (i.e., within acceptable losses).

The diameter and all other bending loss parameters are designed to keep the bending losses at an acceptable level.

The level of loss will depend on cooling requirements of the particular application: some applications with good cooling and no need for high efficiency can have large losses and thus possibly smaller diameters, while systems with poor cooling and needs of very high efficiency will require lower losses and thus typically larger diameters. This is extremely complex and based on many variables. Bending losses are a function of the fiber construction (e.g., core, cladding, coating styles, and refractive indexes), the fiber diameter, the bending diameter, and the laser beam conditions entering the bending section (beam NA multimode/single mode/specific mode content for multimode, etc.)

The selection of the fiber 40 is based on several criteria: it should have low losses associated with Rayleigh scattering, Raman scattering, and infrared radiation; it should have an ultra-low OH content; preferably have a high NA; have high tolerance to external heat load; be able to operate in fluids without degradation to the fiber's ability to transmit power; be free of imperfections in the manufacturing process; and have a durable cladding that permits reasonable handling toughness both during the winding and out-spooling events. A preferable fiber has a pure fused silica core, with doped silica cladding to give a change in the index of refraction, which allows the light to be guided with a NA between 0.22 and 0.37.

Bare or armored fiber 40 exits the drum spooler 38 and thence communicates with the remote system 18, which could be any device, vehicle, or apparatus that is either self-propelled or is carried by a secondary mobility platform either on land, under the sea, in the air, in space, or on Earth or another planet. Desirably, the remote system 18 is equipped with a high power fiber optic coupler 32' so that it can be desirably disconnected from the power plant 16 for maintenance and transport between missions. The fiber internal to the mobility system 18 then terminates in a device 36 that makes use of the optical power by converting it to another form of energy.

FIG. 5B shows a variation of a power plant 16 incorporating a precision-wound axial spooler 50. Instead of a drum spooler (as shown in FIG. 5A), the axial spooler 50 is one in which the fiber 40 is pre-wound in such a fashion that it may be pulled out parallel to the axis of the winding without causing the fiber 40 to twist or hockle. Typically, this requires precision winding equipment that inserts a pre-twist of a certain amount per wrap such that the fiber 40 can pull free in the direction of the axis without twisting.

The nature of the winding must be special for a high power application in which large amounts of energy are transmitted through the fiber 40. These details are discussed with reference to FIGS. 5C-5H. At a minimum, however, a high energy axial fiber spooler 50 will require an active cooling system 54 that chills the fiber 40. An auxiliary passive thermal power dissipation system 56 may be desirable to further transfer unwanted heat to the environment (whether underwater, on the ground, in air, or in space).

A plant-based fiber spooler can be quite large in diameter and therefore limit bending losses. In general, axial spoolers are considered one-time-use devices because there is no reliable nor economical field method for re-spooling and making re-use of the fiber in the fashion that would be possible for a ship-based drum spooler working with jacketed (armored) fiber. Similar to the drum spooler 38 described with reference to FIG. 5A, the axial spooler 50 contemplates high power optical couplers 32 on opposing sides so that it may be field-connected to the laser 22 and to the remote system 18.

FIG. 5C shows a detailed example of one embodiment of a single exterior mandrel 60 referenced with respect to FIG. 5B.

A hollow or solid winding mandrel 60, which is preferably made of a high thermal conductivity material (e.g., beryllia, copper, aluminum), has bare optical fiber 62 wound upon its radially exterior diameter in such a fashion that direct axial pull out parallel to the mandrel axis 64 is possible without introducing twists to the fiber 62. This can be achieved by pre-twisting the fiber 62 during the precision winding process. The bare fiber 62 exits the rear of the spooler 50 and trails in the direction of the laser power source 22. The vehicle moves in an opposite direction 66 along the same axis. The fiber 62 is preferentially attached to mandrel 60 by a high thermal conductivity adhesive (e.g., materials consisting of a base synthetic polymer system containing thermally conductive fillers) such that the adhesive transmits heat directly to the mandrel 60 in an efficient manner and also lightly binds the fiber 62 to the mandrel 60 so that it does not unspool without a constant tension being applied by the exiting fiber 62, said allowable tension level being specific to a particular fiber design and diameter, but with the general characteristics of both binding the fiber 62 to the mandrel 60 so that individual fibers do not slide freely relative to one another and yet not so high as to impede the free spool out of the fiber 62 to a degree wherein it may stress the fiber 62 to a point at which it either breaks under tension or adversely affects the transmission of power (e.g., by cross-sectional thinning under tension). Examples of appropriate adhesives are ResinLab EP 1121-4, Dow Corning SE4450, and the like.

The mandrel 60 will require active cooling for high power applications. To achieve this, internal flow channels 68 are disposed circumferentially through mandrel 60 and are fed by an inlet 70 and exhausted by an outlet 72. The coolant, which may be either actively pumped or passively fed through the channels 68, can be drawn: from the ambient environment in the event that that fluid has a high heat conduction capacity; from a reservoir of high heat conduction capacity coolant (e.g., water, liquid metals etc.) that is actively chilled (and thermal power dissipated non-local to the spooler 50); or from a reservoir of cold material (e.g., cryogenic liquids). In addition, coolant can be caused to flow through the center of the mandrel 60 to provide further heat removal from the spooler 50.

The spooler 50 has an exterior protective housing 74 that also functions as a thermal radiator. The housing 74 may preferentially have a thermally absorbing coating applied to the radially interior surface 76 such that any heat radiated from the spooled fiber 62 is preferentially absorbed by the housing 74 and thermally-conductive coating. The housing 74 further may desirably have internal coolant flow channels 78 that may receive fluid flow from any of the aforementioned coolant sources. The housing 74 may furthermore be advantageously equipped with exterior radiation panels 80 extending along the length of the housing 74. The thermally absorbing coating has good absorbing ability in the infrared spectrum.

Yet another means for removing heat from spooler fiber 62 is that of directed flow of a coolant via inlet ducts 82 that direct the cooling fluid to pass lengthwise down the axial assembly via a fiber feed channel 84 formed between the mandrel 60 and the housing 74, and from which the fiber 62 ultimately exits the spooler 50.

One purpose of all of these features is to maintain the fiber 62 within a working temperature range that will not affect the material or function of the fiber 62 for the transmission of high power optical energy. Silica, and most materials suitable for the purpose of optical power transmission down a small diameter fiber, has a very low thermal conductivity so it acts to impede cooling of adjacent fibers through contact. For this



reason, and as shown in FIG. 5C, the most efficient fiber spooler for high power optical energy transmission is one that contains only a single layer, or only a few layers, of bare fiber 62. Depending on the power levels involved, additional layers may be added and the flow of coolant through channels 68 and other coolant communication paths adjusted accordingly to maintain fiber temperature within the specifications for the selected fiber.

Not shown on this drawing, but of significance to the operation of this system, is a network of surface-mounted temperature sensors that can be used to detect an impending hot spot that may cause the fiber 62 to fail locally or regionally. In this case, these temperature sensors can be tied to the active thermal control system as well as to the laser for a pre-emptive beam shut down in the event of an uncontrollable buildup of heat in any particular section of the assembly.

For reference, a single wrapped axial spooler mandrel that is two-tenths of a meter in diameter by one-half meter in length can carry 1.3 kilometers of 250-micron fiber in a single layer; 2.6 kilometers in a double layer; 3.9 kilometers in a three-layer wrap, etc. There are means for building much longer, high power axial spoolers, as will be subsequently described below.

FIG. 5D shows a cut-away detail of the exterior wrapped mandrel 60 from FIG. 5C. Desirably, for improved heat conduction, the exterior surface of the cylindrical mandrel 60 will contain a smooth, form-fitting groove 86 designed to precisely mate with the chosen bare power delivery fiber. The groove 86 would be preferentially manufactured using a precision machining system or other method of creating a spiral, continuous groove 86 the local radius of which either precisely matches or is slightly larger than that for the chosen power fiber. The degree of machining depth will represent the minimum needed for secure fiber location. For very high power applications, the spacing (pitch) between individual coils of the groove 86 should be such that the adjacent fibers do not touch each other. Further, the edges 88 between the respective grooves 86, as well as the groove surfaces, preferably are polished and have a smooth transition radius such that there are no sharp edges anywhere on the face where the fiber is to be wound. Similarly, the interior trailing edge 90 and the exterior trailing edge 92 have a smooth radius and are polished to prevent fiber damage on spool-out. An alternative to the spooler design shown in FIG. 5D would involve the use of a smooth polished cylindrical external winding surface (replacing the polished grooves 86 and 88 in FIG. 5D), or one that is slightly tapered (with or without alignment grooves 86) toward the direction of fiber spool out so that the diameter of the tapered, truncated conical annulus is less at the point of fiber departure (64 in FIG. 5C) than it is at the opposing end (in the direction of vehicle motion, 66 in FIG. 5C). In both cases, the fiber is adhered to the smooth, polished surface by means of a thermally conducting adhesive means and, desirably, the fiber spacing is such that adjacent fibers do not touch. Multiple fiber layers, held together by a thermally conducting adhesive means, are possible on mandrels as shown in FIG. 5D (and as described in this paragraph), however the ability to effectively cool the multiple wraps will be diminished relative to a single-wrap mandrel and careful thermal design will be required to determine the maximum number of over-wraps for a given power transmission level, mandrel wrapping radius, and diameter of the transmission fiber, among other things.

FIG. 5E shows a top isometric cutaway view of the same external fiber spooler 50 and protective housing 74 described with reference to FIG. 5C. Importantly, the direct axial flow cooling fluid inlet ducts 82 are notional representations only.

For travel through a fluid medium (e.g., water or air) there can be present computer-controlled, servo panels that open to permit either water or air to be drawn into the vehicle as it moves forward and to channel that fluid down into the fiber feed channel 84 for the purposes of cooling the radially exterior surface face of the fiber 62. Because the fiber 62 must freely trail out from the channel 84, any cooling fluid that passes into inlet ducts 82 will exit the fiber feed channel 84 after one pass and not be able to be re-used. Contrarily, any fluid or coolant pumped through circumferential channels 68, 78 can be re-cycled and sent to an alternate location in the vehicle either for the purpose of refrigeration of the coolant or potentially for pre-heating of a working fluid or propellant.

FIG. 5F shows a variation on the axial high power fiber spooler 50 in which the mandrel 60 defines winding grooves 86 on the interior surface. All other aspects of this design remain the same as for those shown in FIGS. 5C-5E, including the presence of circumferential cooling channels 68. Importantly, such a winding pattern depends on the use of the thermally-conducting adhesive to lightly attach each fiber to the groove 86 as the fiber 92 is precision-placed. The groove 86 forms a continuous spiral (helix) and the fiber 62 pays out linearly in a direction parallel to the center axis of the cylindrical mandrel 60. As discussed supra, for the highest power applications, it is desirable to have a single wrap of fiber 62. For lower power applications it will be possible to have several layers of wrapping.

An alternative to the spooler design shown in FIG. 5F would involve the use of a smooth polished cylindrical internal winding surface (replacing the polished grooves 86 in FIG. 5F), or one that is slightly tapered (with or without alignment grooves 86) toward the direction of fiber spool out so that the diameter of the tapered, truncated conical annulus is greater at the point of fiber departure (64 in FIG. 5C) than it is at the opposing end (in the direction of vehicle motion, 66 in FIG. 5C). In both cases, the fiber is adhered to the smooth, polished surface by means of a thermally conducting adhesive means and, desirably, the fiber spacing is such that adjacent fibers do not touch. Multiple fiber layers, held together by a thermally conducting adhesive means, are possible on mandrels as shown in FIG. 5F (and as described in this paragraph), however the ability to effectively cool the multiple wraps will be diminished relative to a single-wrap mandrel and careful thermal design will be required to determine the maximum number of over-wraps for a given power transmission level, mandrel wrapping radius, and diameter of the transmission fiber, among other things.

FIG. 5G shows yet another variation on the high power axial fiber spooler 50. An exterior mandrel 60 of this spooler 50 is the same as shown in FIGS. 5C-5E. The inner mandrel 100 is a variation of the mandrel shown in FIG. 5C and FIG. 5F in which the fiber is wrapped on grooved surfaces on both the radially interior and radially exterior surfaces of the inner mandrel 100. All winding surfaces shown are smooth and tapered in the direction of fiber spool out, 112, with the fiber being held in place and positioned with the use of a thermally-conducting adhesive as described above. Each mandrel 60, 100 is independently cooled via coolant inlet ports 102, 104 and outlet ports 106, 108, which serve to send a recyclable coolant through cooling channels in the inner mandrel 100 and outer mandrel 60. Chilled ambient environment fluid (e.g., water, air) can be routed into the exterior fiber channel 110 or through the hollow central core 111 for additional fiber cooling. The exhaust for such coolant, following one pass through the spooler 50, is in the trailing direction 112. The exterior mandrel 60 may additionally contain passive thermal dissipaters (e.g., radiation panels) as shown in FIG. 5C and

FIG. 5E. The mandrels **60**, **100** are supported at one end only. The fiber is pulled off the free end.

In the design shown in FIG. 5G, up to three single-layer, individually-cooled fiber layers can be combined into a compact spooler to increase the range of the vehicle. The nested mandrel, actively-cooled spooler concept can be extended to several annular ringed mandrels embedded within one another. All fibers are desirably retained in their grooves by the use of a thermally-conducting adhesive or similar means that achieves the same intent. For lower power operations, multiple wraps can be applied to each winding face, both interior and exterior. Each wrap desirably contains an element of pre-twist to prevent hockling upon pullout during a mission. The fiber from one ring layer is desirably passed to the next layer while maintaining the maximum possible bend radius on the fiber. Desirably, the trailing edges (not shown) of mandrels **60**, **100** should have smooth, polished, radiused surfaces to as to present no sharp edges to the trailing fiber nor to the cross-wrap fiber leading from one wrapping face to the next.

FIG. 5H shows a cross sectional detail of an embodiment of a drum-type high energy fiber spooler such as shown in FIG. 5A. For some applications, particularly those involving low speed mobility platforms (e.g., underwater and ground vehicles), it will be possible to use a drum spooler on the mobility platform (vehicle). The advantage of a drum spooler is that it simplifies the winding process and does not require precision winding and fiber pre-twist to assure a straight pull out as the mobility platform moves away from the laser power source. It is therefore likely to be less costly than an axial precision-wound spooler. For very high energy transmission, the drum spooler must be cooled in a manner analogous to that previously described for an axial spooler. The mandrel **60** will necessarily contain coolant flow channels **68**, whether interior to the mandrel body or as a bonded set of thermally conducting flow channels (e.g., a helical tube coil made of copper that is either soldered to the mandrel **60** or bonded to it with heat conducting material). The coolant that flows through channels **68** can be from a closed-cycle system that continuously chills the refrigerant while dumping the waste heat elsewhere, desirably into a power conversion system for use onboard the mobility platform. For applications where the mobility platform will be working in water or air, either passive or actively forced flow of the ambient fluid (e.g., water, air) can be passed over and around the exterior of the mandrel **60** to further remove heat from the fiber. As with the axial spoolers previously described, for ultra-high energy optical power transmission it is advantageous to have only a single wrap of fiber **62** on the mandrel **60**. A greater number of wrap layers is possible for lower power levels or for environments where the ambient environment fluid has significant heat conduction capacity to allow further layers (e.g., ice water for deep ocean, or sub-glacial lake work). The drum can either passively feed fiber **62** out (possibly with tension maintaining mechanisms) or actively with the use of sensors and servo drives **114** that match the rate of fiber pay out to the vehicle forward velocity.

Energy **116** from the base-located laser (not shown) is fed into the spooler **50** and the spooler **50** unwinds as the mobility platform moves away from the laser. The fiber **62** from the spooler **50** terminates at a high energy optical coupler **32** where it enters the rotating element **118** of a high power fiber optic rotary joint (FORJ) **120**.

The FORJ **120** is described in detail hereafter with reference to FIGS. 9-10. Briefly, this device allows the optical energy **116** to be transmitted between two adjacent fibers while allowing for one half of the FORJ **120** to rotate relative

to the other. By this means, the drum spooler **38** may rotate freely without twisting the fiber **62**. The output side of the FORJ **120** leads to a second coupler **32** and fiber section **122** that transports the coherent optical energy **116** to the vehicle for further use. The drum spooler **38** is supported by bearings **124** on one or both sides. The bearings **124** are held in place by a drum frame **126** that is fastened to the body of the mobility platform. Both the drum frame **126** and drum side-walls **128** may have optional internal cooling channels depending on the power levels involved. The fiber **62** is preferably a bare fiber, since a much greater length can be stored in a given-size spooler drum **50**, but there is nothing preventing a jacketed fiber to be used, provided the jacket and cladding and any other protective or strengthening elements have high thermal conductivity. Notably, bare fiber always has cladding and almost always has a coating of tens of microns that is not a jacket but nonetheless protects the fiber to a degree.

FIG. 6 depicts an alternative embodiment of the invention wherein the power spooler **50** resides on the mobile remote system **18**. All elements in FIG. 6 are identical to that of FIG. 5B with the exception that the fiber spooler **50** is now mounted on the vehicle. This architecture, wherein massive amounts of optical power are transferred to the vehicle over a fiber optic link over long distances with the vehicle carrying, and laying, its own power line, is the key to enabling a class of mobile, autonomous systems that could never have previously existed owing to limitations of weight and power generation or storage capability. As an explicit example, the range (both horizontal distance and depth rating) of a ship-tethered ROV (industrial class remotely operated vehicle) of the type commonly used in the petroleum industry is severely limited by the excessive size and mass of that electrical-power tether, which grows larger with distance (because higher voltages must be used and this then begets further electrical insulation requirements) and is significantly affected by ocean current drag. There are thus practical limits today to where ROV systems can operate. By contrast, a 1 mm diameter jacketed fiber optic laser power tether would scarcely be affected by currents and the vehicle could receive useful optical power as far as 100 kilometers from a ship-carried power supply.

In FIG. 7, we explain the first of several high power energy extraction methods to be employed on the remote system **18** of FIG. 6. The coherent energy **130** coming from the onboard fiber spooler (not shown) is injected into one or more sets of passive or actively controlled beam forming optics **132** comprising lenses, fiber assemblies, mirrors, prisms, etc, all types of optical manipulating devices. The energy **130** is expanded and directed toward a refractory target **133** such that diffuse laser radiation illuminates a beam dump **134**. The beam dump **134** is a body preferably made of a refractory material (e.g., beryllium oxide (BeO)) that can tolerate sustained high temperature operation. Other high-temperature compatible, highly conductive materials (e.g., certain metals) could also be used as the beam dump. The core of the beam dump **134** is desirably surrounded by an array of thermoelectric converters **136** whose interior side contacts with or is exposed to the hot beam dump **134**. The exterior side of the thermoelectric converters **136** is advantageously exposed to a cold environment or to a heat sink means that is either actively or passively chilled to create the greatest temperature difference across the thermoelectric converter mechanism. Additional heat exchanger channels **138** may be run through and around the beam dump **134** to extract heat for further directed use throughout the vehicle or for further power generation by additional thermoelectric arrays or other means.

One such direct heat use for coolant coming through the heat exchanger system would be that of heating melt water to high temperatures and pressures and using that with a pump **140** to form of a hot water jet for hot water drilling through a thick ice cap—for example the three-kilometer thick ice cap of Antarctica. Another use would be to supply hot working fluid through a pump **142** for thermal management of a mobility platform (e.g., to keep a planetary robotic rover's mechanisms and science payloads from freezing). The thermoelectric converters **136** send electrical power to the onboard control system via a power bus **144**, which is regulated by a power management sub-system **146**. Electrical power is subsequently stored in one or more regenerative electrical power storage means **148** (e.g., a Lithium-ion battery stack, a fuel cell stack, etc.), which serves both as the primary continuous power source for the main onboard computer control processor **150** and controls for peripherals such as the pump actuators **152** that control the hot water jet pump **140**, thermal management pump **142**, mobility motors, and the like. The mobility system is desirably equipped with a sophisticated sensor network **154** that continuously scans dozens of process sensors **156**—thermal, pressure, and optical—for overall management of the vehicle.

FIG. **8** shows a physically realizable mobility system power head **160** that can receive very large amounts of optical power (e.g., tens of kilowatts to low megawatts) and thence convert and simultaneously direct that energy in several useful ways to further the purpose of the mobility platform of which it forms the heart. Optical power is delivered to the power head **160** via fiber **162** from an axial or drum type spooler as previously described and located on the mobility platform. The beam is first partially expanded via primary beam forming optics **164** and then via forward beam forming optics **166** to form a diffuse beam **167** that impinges on beam dump **134**, thus heating the entire body of the power head **160** to high temperature. As previously described, a thermoelectric converter array **168** may be positioned around the beam dump **134** for direct generation of electrical power for use on the vehicle. This array **168** can be located anywhere around the power head body where heat will be radiated onto one face of the thermoelectric converter chips (TEC) while a lower temperature surface can be created on the opposite side (e.g., the TEC array could be located either inside the beam dump cavity and cooled on their outward side by heat exchanger channels **176** or by mounting the TEC array on the outside of the beam dump as shown in FIG. **7** where it would be chilled by the ambient environment or other external heat extraction system). A second primary means of direct electrical power generation is possible by directly impinging the expanded optical beam **167** onto an array of photovoltaic cells **170** that are tuned to generate electricity efficiently at the wavelength of the incident laser radiation. The body of the power head **160**, comprising forward housing **172** and rear housing **174**, can be equipped with internal heat exchanger channels **176** and heat pump channels **178** that can be used to transport heat to other locations about the vehicle for thermal control in cold environments or to power such direct thermal power consumers as hot water drills and the like.

FIG. **9** shows one embodiment of a high power (e.g., kilowatts to low megawatts) FORJ **180** as generally described with reference to FIG. **5A-5H**. The housing of the FORJ **180**, in this case an axial design, comprises two concentric elements: a rotating element **182** that rotates freely and is mounted to the rotating fiber drum (not shown) by flange **184** and a fixed element **186** that is fixed to the drum holding frame

(not shown) and is prevented from rotating by torque arm **188**. The rotating element **182** and fixed element **186** together define an optics chamber **195**.

Optical power enters the axial FORJ **180** through a first connector **190**, which is cooled by coolant that enters at inlet port **192**, cools the connection and exits at outlet **194**. However, at this point coolant flow is subsequently routed to housing inlet **196** where it cools the fixed element **186** and then, by means of a rotary cooling water coupling **198**, allows the flow to continue into the rotating element **182** without entering into the optics chamber **195**. Water temporarily exits the rotating member **182** and connects to a cooling inlet **204** of a second connector **202**, cools the second outlet connector **202**, and exits the second connector **202** at an outlet port **200** and then re-enters and re-cools the rotating element **182**, passes back through the rotary water coupling **198**, passes through the fixed element **186** and then exits to return to the cooling system via outlet port **206**. Many variations on this approach are possible, but the concept is to efficiently cool both the rotating element **182** and fixed element **186** of the FORJ **180** as well as both fiber connectors **190**, **202** using the same coolant system for economy. O-ring radial and face seals **208** are used to ensure that water does not enter the optics chamber **195** or optical elements of the FORJ **180** nor to leak at any place while advantageously transporting heat away from both housings elements **182**, **186**.

The rotating element **182** is supported and centered within fixed element **186** by bearings **210**, which are kept clean and sealed by a shaft seal **212**. Electric slip ring contacts **214** are used for connector safety interlocks and are connected to a safety control system by external wires (not shown). The purpose of the safety interlocks is to prevent accidental separation of the FORJ **180** while power is on. Additional safety sensors comprise a plurality of photodetectors **216** for sensing stray light that might predict the onset of failure of the optics that would lead to a catastrophic melt down of the system if left unchecked. Similarly, a temperature sensing network **218** is distributed throughout the rotating element **182** and fixed element **186** for the same purpose of early detection of a failed optical control system that may be leading to melt down of the FORJ **180**. Similarly, isolated electrical contacts **220** for connector integrity lock are provided to ensure both the first and second connectors **190**, **202** are properly inserted and locked in place.

The optics of the axial FORJ **180** are complex. The incoming beam from the first connector **190** will diverge at its end at the fused silica block at a divergence angle defined by its numerical aperture (NA). The diverging beam is collimated by first collimating optics **222**. The beam then theoretically travels across the evacuated optics chamber **195** and impinges on second collimating optics **224** where the beam is focused and impinges on the fused silica block of the second connector **202** where the beam is injected into the output fiber **203**.

Despite the best efforts at precision machining, there will exist alignment errors between connectors **190**, **202** and their respective collimating optics **222**, **224**. Minor variances in this alignment could result in substantial amounts of power being dissipated in the optics chamber **195** and, if left unchecked, could lead to meltdown and loss of the device. While fine-tuned optical bench solutions might be developed for laboratory versions of such a device, that will not be sufficient for the high power industrial mobility inventions previously described herein.

To resolve the issues of alignment both due to axial and angular errors as the rotating element **182** rotates relative to fixed element **186**, actuators **226** are affixed to the first and second collimating optics **22**, **224** for interactively, and with

fine precision, moving these respective lenses in real-time under computer control. Alignment means **226** may comprise of a plurality of active control elements affixed to each lens such that each lens can be both moved in three degrees-of-freedom (e.g., X, Y, and Z translations) as well as rotated

in three degrees of freedom (yaw, pitch, and roll) in order to both actively change both the focus point as well as the pointing of each lens.

The connectors **190**, **202** will have limited alignment possibility, other than that determined by the precision of the concentricity of rotating and fixed elements **182**, **186** and the degree to which fabrication errors and tolerances permit motion other than rotationally about the common centerline. For this reason, the actuators **226** must handle all of the correction. The actuators **226** may desirably be arrayed radially about the perimeter of the lens and a minimum of three such elements per lens would be needed to provide a full six degrees of freedom. Alternatively, the lens could be held by an external servo controlled stage that allowed for X-, Y-, and Z-translation of the lens while other servo actuators provided for the yaw, pitch and roll orientation. The lens actuator means could employ both slow and fast elements—fast elements being comprised of such technologies as piezoelectric stacks with or without displacement amplifiers; MEMS-based actuators for micro-fine tuning; acoustic SAW wave linear actuators; electromagnetic and voice coil type actuators, to name a few. Importantly, these actuators are all driven by an onboard embedded computer processor that is local to the FORJ **180** or immediately adjacent the FORJ **180** so that each FORJ **180** is independently responsible for its own real-time alignment. The alignment cycle begins at low power and a system identification mapping is performed at specified rotation angles of rotating element **182** relative to the fixed element **186**. At each system identification angle, an optimization is performed in which the delivered power to the output connector is maximized while minimizing the optical and thermal feedback from internal sensor networks **216**, **218**. The positions of the collimating elements **222**, **224** are then noted and the next angular alignment proceeds automatically until a full revolution has been logged. A smoothed mapping is then mathematically defined between the discrete calibration points and this mapping then forms the basis for an initial estimate of the real-time alignment system at any given angle—the relative rotation angle between the rotating element **182** and fixed element **186** is determined by a high precision angular encoder (not shown) that reports that angular position to the embedded control system processor. With these initial seed alignments as a function of relative rotation angle the embedded processor then initiates a real-time optimization control of the collimating alignment motors and actuators for both lenses as power is ramped up to full industrial levels and the fiber is spooled out from the spooler drum.

FIG. **10** shows another embodiment of an FORJ **180** that can be used with the present invention: a right-angled, high power FORJ **180** in which all elements are the same as for FIG. **9** and further comprises a high power actively cooled laser mirror **230**. The mirror **230** is mechanically connected to highly responsive servo-controlled mirror alignment motors and actuator means **232** sufficient to control three orthogonal translations and three rotations (yaw, pitch, roll) of the mirror **230** relative to collimating optics **224**, **226**. These actuators and motors **230** are, as before, connected to the onboard embedded processor which seeks to optimize the amount of optical power being transferred through the FORJ **180** for any given rotation angle. This is in many ways superior to the pure axial design presented in FIG. **10** in that it allows for extremely fast adjustment of a lightweight, cooled mirror (as

opposed to glass optics which have substantially more mass). Furthermore, the addition of the servo-aligned mirror has the capability to compensate for translational misalignments between the axes of the assembled FORJ connectors **190**, **202**. This additional alignment was not possible in the axial FORJ of FIG. **9** because the relative beam input angles are pre-determined by the machining precision of the connector entries. In the FORJ **180** of FIG. **10**, this machining precision error can be completely compensated, leading to reduced losses and at higher response speed. The same initialization alignment system identification and radial optimization will be conducted, but with the addition of the degrees of freedom of the mirror added to the optimization algorithm.

FIG. **11** shows an exemplary optical connector **300** suitable for use in the present invention. The connector **300** has a fused silica beam expansion block **302** with a wavelength-specific anti-reflective (AR) coating contained inside an optical fiber cable assembly **314** with multi-layer armored jacket. Because power is lost in the connector **300**, water cooling is fed through the connector by water cooling inlet line **308** and water cooling outlet line **310**. The connector is typically equipped with a mating flange **312** for a bolted connection. A dust-intrusion o-ring **316** prevents dust particles from entering the optical pathway and potentially causing a localized thermal buildup by blocking the beam. Two radial contact isolated electrical contacts **318** provide for a test of cable interlock integrity.

FIG. **12** shows the heat engine **160** described with reference to FIG. **8**, the heat engine **160** comprising a high temperature housing **320** and an internal beam dump **176**. The laser power enters the heat engine via fiber **162** coming from the power spooler (not shown). The beam is expanded through primary optics **164** and secondary optics **166** into diffuse beam **326**, which is directed into refractory beam dump **328**. Heat can either be transferred directly through the walls of the beam dump **328** or via an external heat exchanger **330** that cycles an effective thermal transfer fluid (e.g., liquid sodium) through the beam dump **176** and back into a high-power heater **332**.

A beta Stirling engine **334** is driven by the heater **332**. The engine **334** comprises an expansion volume **336**, a compression volume **338**, a displacer **340**, a power piston **342**, a regenerator **344**, and a cooler **346**. The expansion volume **336** and compression volume **338** are preferably filled with a working gas, which is typically air or helium. This working gas is sealed within these volumes by the power piston **342** and moved between the hot and cold spaces by a displacer **340**. The gas is recycled through the cooler **346** and through regenerator **344** prior to re-entering the heater **332**. The linkage driving a power piston **342** and displacement piston **340** will move such that the gas will compress while it is mainly in the cool compression space and expand while in the hot expansion space. Because the gas is at a higher temperature in expansion space **336** relative to the compression space **338**, and therefore at higher pressure, more power is produced by the movement of piston **342** during expansion than is reabsorbed during compression. This net excess power is the useful output of the engine. There are no valves or intermittent combustion, which is the major source of noise in an internal combustion engine. The same working gas is used over and over again, making this a sealed, closed-cycle system. All that is added to the system is steady high-temperature heat, and all that is removed from the system is low-temperature (waste) heat and mechanical power. The piston **342** can be used to drive a plurality of electrical generation means. This design, using ultra-high laser-delivered power, forms the

basis for a unique power generation mechanism that is non-collocated with the source of the energy.

The power levels being dissipated in heater **332** can range from the low kilowatt level to a dozen megawatts using a single fiber. Electrical power conversion efficiencies for a properly designed Stirling engine can reach thirty percent. A megawatt of laser input power could be converted to five-hundred horsepower of electrical drive power. Ten megawatts, feasible with an eight-hundred micron fiber, would yield five-thousand horsepower, which is sufficient to run heavy machinery, such as to conducting mining operations eleven kilometers below the surface of the ocean at the bottom of the Marianas Trench, powered by a ship-board diesel power system driving the laser, or to power a fleet of remotely operated lunar regolith harvesters extracting ice on the Moon, powered by a lunar base nuclear power system using a similar Stirling converter to power a laser. Both of these, as well as many other extreme environment applications, ideally favor this approach as the cooler **346** can easily extract cold from the environment. All of these systems can be operated at tens of kilometers from a static power base using the approaches described herein.

FIG. **13** shows a robotic device **348** (a “cryobot”) designed to autonomously penetrate extremely deep glacial ice caps (e.g., the Antarctic ice sheet over Lake Vostok, the South Pole Lake, Lake Ellsworth, other such sub-glacial lakes, or even the ice caps of Mars or the surface ice cap of the Jovian moon Europa) by melting a path ahead of the vehicle as it descends. Prior to this disclosure, no attempt at the construction of a practical cryobot has succeeded, largely because of two factors.

First, prior attempts at using electricity (in a device known as a Philberth Probe) all failed at slightly over a kilometer of depth. For practical reasons—namely, the ice cap freezes behind the probe as it melts its way down—the vehicle must spool out its connection to the power source from the vehicle. This requires a large spool of wire on the vehicle. Because of resistive losses, the voltage must be increased the further the vehicle descends until eventually arc-over limits the range.

Second, political restrictions on the use of nuclear power sources in Antarctica. While a small SNAP reactor could power such a device, it would never be tested in a deep ice cap on Earth.

A laser-powered cryobot, such as the cryobot **348** disclosed in FIG. **13**, changes that. Enough fiber can be carried on the vehicle to permit not only a descent through the deepest known ice caps on Earth—four thousand meters at Vostok—but also to permit a sample return mission by inverting the cryobot and melting its way back to the surface.

The advantages of such a system are further enhanced by environmental restrictions imposed by the international community regarding entry into such subglacial lakes. Planetary Protection restrictions require extensive testing, certification, and lengthy approvals that can take years to decades to approve access using hot water drilling from the surface, which is the only other known technology that can reach these lakes.

With a cryobot, the vehicle can be sterilized to acceptable levels in the laboratory, sealed in a sterile container, and inserted into the ice cap in a sterile condition. Because the melt hole re-freezes only a few meters behind the vehicle, forward contamination is prevented.

The design of a cryobot is governed almost entirely by the diameter of the vehicle and the desired descent rate through the ice. This, along with the temperature of the ice, determines the input power requirements. For example, a one-quarter meter diameter by two-meter long cylindrical cryobot with

hemispherical end caps, similar to the cryobot **348** depicted in FIG. **13**, working in ice with a temperature of minus five degrees (C.) will descend at a rate of fifteen to twenty meters per day when powered by a five-kilowatt fiber laser. Doubling the diameter (e.g., to accommodate larger science payloads) will reduce the descent rate by a factor of four under the same input power.

FIG. **13** discloses one embodiment of a viable, deep ice cryobot **348** having a cylindrical shell **350** with hemispherical ends. Power is delivered via a bare optical power fiber **352** to the rear (top) of the vehicle. Data may be modulated and extracted via the power fiber **352** so that a surface-based mission control center could maintain a high-bandwidth data link with the cryobot **348** throughout the mission. The cryobot **348** may be equipped with an auxiliary (second) co-linear axial spooler **354** having an auxiliary fiber of smaller diameter than the power fiber **352** for the purposes of maintaining a dedicated communications link. This is of considerable value for the purposes of supervised autonomy in which a surfaced-based scientific or industrial team could interpret real-time data and override local autonomous behavior code for such purposes as collecting a sample from the adjacent ice column or for potentially causing the vehicle to deviate from a direct vertical descent. A primary power fiber spooler **356** is surrounded by actively-controlled chill water heat exchangers **358** that melt water from the front of the vehicle. When a cryobot melts through an ice cap, the bubble of water that surrounds it sees the hydrostatic pressure of the ice mass above it, such that by the time it penetrates a sub-glacial lake at, say, four kilometers depth, all of the sealed components within the vehicle will see four hundred bar (forty MPa) applied external pressure. The design must therefore include provision for either structurally resisting that pressure or for allowing compliant equalization of pressure (through the use of oil filling and a compliant accumulator). Pressure housing **360** houses the primary onboard control computer, and guidance, navigation, and thermal management electronics. Its temperature is maintained within a functional band by heat exchanger **362**.

A science or sample bay resides at the center of the vehicle and can include, among many possibilities, water sampling pumps **364**; water sampling router valves **366**; a lateral ice wall sampling system **368**; a lateral ice wall imaging system **370**; and potentially a lake floor sediment sampling system. Preferably, the cryobot **348** includes one or more regenerative power storage systems **372**. A pump **374** provides both heated and chilled water as needed to the various heat exchangers throughout the vehicle. Science sample carousel **376** can be used for storage of a score or more of filtered water samples. A high-pressure jet pump **378** draws hot water from hot water heat exchangers **380** and drives the heated water through hot water first stage jet feed lines **382** to hot water jets **384** located at the nose of the vehicle. Selective transfer of hot water to different jets (there may be as many as needed) for the purpose of auxiliary or primary steering of the vehicle for the purpose of obstacle avoidance maneuvering. Melt head actuators **386** provide primary or auxiliary steering of the melt head, also for the purpose of obstacle avoidance maneuvering.

As previously discussed, optical power reaches the refractory melt head via fiber and passes into a melt head housing **388** through a fiber junction block **390** and primary and secondary optics **392**, **394** that diffuse the beam and cause it to impinge uniformly on a beam dump **396**, where it heats the refractory material **398** to high temperature. Electrical power can be extracted in several ways, the most effective for this

low power (electrical) operation being a thermoelectric array **400** that takes advantage of the exterior cold (melt water) environment.

Importantly, the nose of the vehicle contains a synthetic aperture radar (SAR) **402** antenna (the electronics for which are located in the pressure housing **360**) that is tuned to one or more frequencies (operated independently or synchronously) optimally chosen for penetration of ice. Because of the relatively slow, uniform rate of descent, it is possible using SAR to build a high resolution map of what is ahead of the vehicle (including both liquid voids and solid objects) and to take appropriate evasive action to avoid those features if necessary. This behavior can be programmed as a robotic function onboard the vehicle and can operate without human intervention. In order for the SAR system to operate the material of the beam dump and melt head **398** must be made of a radar-transparent material. A suitable example, which is also a refractory material, is beryllium oxide. The front of the vehicle advantageously also contains a miniature, pressure-proof fiber video or still camera **404** for the purposes of documenting the ice in front of the melt head. Fiber cam illumination may include pressure proof array of high intensity LEDs **406** or other compact illumination source.

FIG. **14** shows the field setup for a laser-powered cryobot mission. A high power fiber laser **408** is electrically operated through power supplied by a diesel generator **410**. The diesel generator **410** also provides electrical power for operation of a pumped chill water coolant system **412**, which provides chilled water for thermal control of fiber laser **408**. A high power in-line coupler **414** connects laser **408** to a modular high power process fiber **416**, which carries the laser energy over land over some intermediate distance (preferably as short as possible) to provide flexibility in the location of the laser power generation source away from the cryobot injection point into glacier **418**. At the injection point, a melt hole entry cab **420** serves to lower the cryobot **348** into the glacier during the initial insertion until the vehicle is submerged into a hole, which is pre-melted so that liquid water is available for system cooling. The entry cab **420** also contains a high power laser fiber coupler **422** that allows the vehicle to be transported to the entry melt hole in a modular fashion, independent of the surface segment of the laser transmission system. The cryobot **348** is also equipped with a high power laser fiber coupler **424** at the melt head. This allows the high power laser fiber spooler **356** to be modularly replaced in the field.

FIG. **15** shows a detailed system schematic for a physically-realizable cryobot capable of reaching the South Pole Lake (located twenty-eight hundred meters directly beneath the United States scientific outpost at the south pole) in thirty days, descending through the lake to its bottom, changing its attitude to that of a horizontally-oriented AUV, collecting a sediment sample from the bottom of the lake, and then inverting to a melt-head-up orientation, making itself positively buoyant, and thereby allowing it to melt its way back up through the ice cap in a similar thirty-day egress mission. The objective is to provide the sediment sample return without the use of hot water drills.

The surface segment consists of two one-hundred kilowatt diesel generators **426** that supply three twenty-kilowatt fiber lasers **428**. The output of each twenty-kW laser is fed to a matched coupler **430** through an approximately three-hundred micron diameter bare fiber core **432**. Approximately eight kilometers of this bare transmission fiber are wrapped on high power fiber spooler **434**, which resides inside the tail cone of the cryobot. Laser input power from the fiber **432** is fed into beam forming optics **436** where the beam is expanded into beam dump **438** that is surrounded by thermoelectric

converter arrays **440**. The impinging beam **442** could, contrarily, be focused to create a stable plasma in a working gas at the center of the refractory thermal flywheel. The result is the same: the conversion of coherent laser energy into radiant heat. This heat is extracted directly for mechanical tasks by heat exchanger **444** and this hot water may be both used to control other parts of the vehicle using thermal management pumps **446** that can be made to pump both heated and cold melt water to locations where needed. The hot water from heat exchanger **444** is also desirably sent directly to high pressure pumps **448**, where it can be directed to hot water jets for the purpose of enhancing the rate of vehicle descent.

The raw electrical power generated by arrays **440** is fed through power bus **450** to a series of power management modules **452** with redundant elements present to provide increased mission assurance. Regulated power from modules **452** is sent to regenerative power storage means **454**, which can store power in the form of lithium-ion batteries, fuel, cells and the like. These electrical power storage systems provide the standard power bus for all cryobot onboard systems.

The main system executive resides on computational processor **456**, which in turn communicates with the surface via data conversion switch **458** that converts electrical data communications impulses into light impulses which are then fed into communications fiber spooler **460** which contains eight or more kilometers of smaller diameter fiber **462** than that used for power transmission. This is then re-converted to a digital signal on the surface via converter box **464** (e.g., a fiber optic to Ethernet switch) and thus provides a common data feed to mission control **466** for monitoring and control of the mission.

The main processor **456** also communicates with a real-time vehicle sensor net **468** that reads scores of environmental state sensors **470** (e.g., thermal, pressure, optical) that are used to provide input into the vehicle thermal management and safety override sub-systems. The processor **456** also communicates and controls the Trajectory Diversion and Attitude Control System, which is composed of a flux gate compass **472**; vehicle roll sensor **474**; vehicle pitch sensor **476**; melt head pitch sensor **478** and actuators: longitudinal center of gravity shifter **480**; radial center of gravity shifter **482**; and melt head pitch drives **484**. These systems and sensors allow the vehicle to not only allow deviation of the vehicle trajectory from a direct, gravity-driven vertical descent through the ice, but also permit the vehicle to fully invert—a process that takes time, but is feasible with the stated systems for moving the vehicle mass centroid to an eccentric position. This allows for enhanced obstacle avoidance and also a sample return or abort to surface.

The vehicle contains an auto-egress system that works in conjunction with the center-of-gravity shifters. This includes a variable buoyancy engine **486**; an emergency ballast drop system **488**; and an “ice tractor” system **490**. The cryobot begins its mission in a head down position (as shown in FIGS. **13-14**) and maintains this orientation, assuming no obstacle avoidance is required, until it reaches a sub-glacial lake. It then uses the longitudinal center-of-gravity shifter **474** to cause the vehicle to rotate ninety degrees up to a horizontal attitude; the radial center-of-gravity shifter **476** allows the vehicle to roll to a preferred pointing direction so that formerly lateral-looking science payload sensors can be made to look directly at the lake bottom. The variable buoyancy engine **486** can be used to cause the vehicle to descend and hover at a specified altitude over the lake floor while a sediment core sample is taken. The complete science payload can contain, for example, imaging systems **492**; environmental

sensors **494**; lake bottom sediment core sampler **496**; lake bottom sonar profiler **498**; and water samplers, including filter samplers **500**.

At the conclusion of the data collection phase of a mission (and the acquisition of the desired core and water samples) the variable buoyancy engine **486** is caused to dump ballast (sterile water). The center-of-gravity shifters invert the vehicle to a head up position and the vehicle begins to melt its way upward, using the positive buoyancy of the vehicle to drive it upward in a bubble of water. An optional, emergency ballast drop-weight (made of a neutral, non-corroding, sterile material) system **488** may be activated if there is a failure in the variable buoyancy system **486** fails on ascent. Lastly, an optional “ice tractor” **490** can be employed to assist in ascent by providing a ratcheting mechanism that allows the vehicle to mechanically force itself forward (i.e., upward). This can comprise direct lateral spur gears that can be extended from the body of the cryobot and driven either by pumped water or electrical motors or it could be of a form consisting of a temporary lateral locking mechanism (e.g. a pressure cylinder and blade pressed against the ice laterally) and a translational ratchet that advances a specified distance up the body of the vehicle, locks to the wall (using a similar lateral force application mechanism means) and then releases the lower latch and a draw motor (e.g. a linear actuator, or gear driven linear track means) pulls the vehicle forward. The intent of the ice tractor **490** is to maintain contact between the melt head and the advancing ice column.

Importantly, the vehicle also contains an Obstacle Avoidance and Navigation System, which contains a forward-looking ice-penetrating low frequency radar (e.g., 100 MHz) **502**; a forward looking mid-frequency ice penetrating radar (e.g., 400 MHz) **504**; a depth sensor **506**; a high precision gravimeter **508**; and an odometer **510**. The ice-penetrating radar (IPR) system forms a part of the SAR system previously described and can be used to dramatically enhance the ability of the vehicle to detect large objects as far as a kilometer ahead of the vehicle and small (centimeter-scale) objects as far as fifty meters ahead of the vehicle. Further, for Arctic and Antarctic operations on Earth, the top roughly fifty to one-hundred meters of ice is not solid. This is a transition zone between fresh, loose snow and solid ice known as the “firm” layer. Because it is not made of solid ice, a cryobot returning to the surface using positive buoyancy will eventually not be able to cause the vehicle to rise to the surface because air content in the firm will cause a bubble of air to form at the head of the vehicle. The ice tractor **490** will overcome some of this and a cryobot of the type described here will be able to rise to within fifty meters of the surface before both buoyancy and lateral ability to hold load will fail. At this point a surface-based recovery procedure is needed that employs a hot water drill to penetrate to the vehicle. An auto-docking and latching system can be created to retrieve the vehicle at that point. Knowing where to drill, however, is a critical part of this recovery procedure and for this the SAR radar now is used as a directional beacon for the drilling system.

FIG. **16** shows another embodiment of the invention in which a laser power generation system **512**, residing on a planetary lander system, is used to remotely power an exploration and science rover **514**. The advantages of this approach are significant in that the rover **514** can be made much more lightweight and agile—and therefore survivable—in a rugged, unknown environment. Furthermore, it allows for the costly, heavy power generation equipment to remain with the lander (or planetary base) and therefore reduce the risk of losing that precious resource were there to be an accident with the rover **514**. This approach can be used to either power

multiple rovers from the same power source or to allow many long range missions by a single rover. The concept can be further extended to one in which a fixed planetary base—for example, a lunar polar base in a deep, sun-less cold crater mining water ice—can use a common central planetary (nuclear) power supply generating power in the five-hundred kilowatt to multi-megawatt range to operate a remote, distributed fleet of large industrial regolith harvesters that scoop up the surface dust and extract water through direct heating.

The planetary lander laser power system **512** generally comprises the elements previously described. The power supply **516** for laser **518** is preferably provided by a compact radiothermal generator (RTG) for lightweight initial robotic missions or a planetary high power (nuclear fission) thermal source for industrial operations, either of which are subsequently converted to electrical power using any of the means previously described and then used to drive the laser. Photovoltaics could also be used to provide power but this is not an option for outer planet exploration and resource extraction (due to insufficient solar flux).

The mobility system **520** comprises the common power train previously described, which includes a rover-based fiber spooler system **522** that receives laser energy via inlet fiber **524**, which is trailed out behind the vehicle as it moves from onboard fiber spool **526**. The fiber spool **526** is cooled by actively controlled heat exchanger and chiller **528** and passive heat dissipation system **530**. A high power fiber coupler **532** allows connection of a beam dump **534** via process fiber **536**. Thermoelectric arrays (or other electrical power generation means previously described) send electrical power via power bus **538** to a power management system **540** which charges or recycles a regenerative energy storage system **542**. Direct controlled power from the regenerative power storage system can be delivered at high current capacity to individual motor or actuator controllers **544** that can be used to drive discrete wheel drive electric motors **546**. Onboard computer system **548** makes behavioral decisions either autonomously or scripted and sends digital control signals via digital links **550** to operate the discrete motor or actuator controllers. All systems composing rover mobility system **520** are carried onboard the actual rover **514**.

FIG. **17** depicts another direct variation of the invention in which an unmanned underwater vehicle receives power in a directly analogous fashion as that described in FIG. **16**. There are two noteworthy differences in FIG. **17** vis-a-vis FIG. **16**. First, the laser and laser power supply are based on a floating platform (e.g., an offshore oil rig or complex) or a ship as part of a ship-based power system **552**. Either mission-specific, dedicated diesel-electric power can be provided or the onboard power plant for the ship or platform itself (likely either diesel or nuclear) can be used to provide an essentially unlimited amount of input power to the laser. This is an important factor as it permits (unlike an RTG-powered planetary lander, for example) industrial power levels to be optically transmitted to the underwater vehicle. For the same reasons as discussed earlier, there are severe limits to the amount of power an electrically operated underwater vehicle can receive from the surface. The design of a high powered ROV for work at three kilometers depth, for example, is a complicated undertaking and the management of the cable alone is a major logistical cost and serious burden which limits the class of ship that can be used to conduct the work. While there are line losses associated with laser power transmission (see FIG. **1B**), and further losses associated with conversion of the delivered energy into electrical power, those are a relatively small issue where there is plentiful electrical power on the surface. The laser-powered AUV **554** or ROV

can competitively be operated against the mechanically inefficient current state of industrial ROVs being used for the offshore oil industry. Further, with the laser-powered approach shown in FIG. 17, it becomes realistically feasible to conduct high power industrial operations anywhere under the ocean, to full ocean depth (eleven kilometers).

The mechanism for power conversion for underwater vehicle applications shown in FIG. 17 will likely be a heat engine (e.g., Stirling cycle) as this can be efficiently, and economically scaled to very large, continuous power levels (thousands of horsepower). Unlike the planetary robotic landers, regenerative electrical power storage systems will largely be for clean (low electrical noise) operation of onboard control, sensing, and communication and for limited emergency maneuvering. The actuators (e.g., main thrusters) will be driven directly from the electrical power output (generator) driven by the heat engine. The architecture shown in FIG. 17 creates an entirely new design space for underwater vehicles. Because the power fiber can be very small in diameter (e.g., one megawatt through an eight-hundred micron fiber) and because the vehicle has control of its own trajectory (because of the on board fiber spooler), it becomes logical to run not only traditional surface-controlled ROVs, but also AUVs with this method, regardless of the degree of human intervention with a preprogrammed mission that may be carried out autonomously in these last two cases. The ability to ditch the majority of the vehicle batteries means less requirement for expensive syntactic (ocean depth rated floatation foam) and the entire vehicle becomes able to be reduced to its key functions of high power mobility and its designated mission task (e.g. repairing a deep pipeline; harvesting manganese nuggets off the deep ocean floor, etc.).

A dramatic variation of the invention is shown in FIGS. 18-20. For nearly three decades, intense research has been conducted on the subject of laser or microwave powered launch of spacecraft from the ground to Low Earth Orbit (LEO). These concepts involve direct beaming of a laser, or banks of lasers, at a target launch vehicle in order to either directly ablate an expendable material on the back side of the spacecraft to create thrust or to heat a working fluid within the vehicle, generally using mirrors on the periphery of the vehicle to reflect the light towards a reaction chamber where the working fluid is to be heated, and then expand the working fluid through a nozzle to create thrust. Regardless of the method chosen, all of the approaches thus far attempted with laser launch have failed for three primary reasons: atmospheric attenuation of the beam; atmospheric distortion of the beam; and line-of-sight limitations. For an object to reach a stable orbit in LEO, it must reach an altitude of approximately three-hundred kilometers or more, but more importantly, it must accelerate to a tangential velocity of approximately eight kilometers per second. The launch trajectory is thus curved and carries the vehicle a substantial distance horizontally away from the launch site before orbital insertion parameters are met. Tracking of the vehicle and attempting to keep the beam locked onto it becomes a daunting task. Schemes have been proposed to have multiple beaming stations around the Earth to deal with the problem of not being able to keep a single beam locked onto an ascending vehicle when it goes over the horizon, but these would represent wasteful duplication of expensive laser power generation systems. Similar drawbacks apply to microwave power beaming. Both approaches are significantly degraded by weather.

FIG. 16 presents the generic concept of fiber laser launch. Similar to the previous discussions, a ground-based laser power generation station provides very large amounts of power into fiber 560, which is spooled out from a launch

vehicle 562. The ground station consists of power source 516; laser chilling station 564; laser 518; high energy process fiber 566; and inline couplers 568. A spooler 570 on the vehicle 562 is chilled by any of the means previously identified, but in the case of laser launch an additional coolant could be in the form of a cryogenic working fluid (e.g., liquid hydrogen, liquid nitrogen) that is stored in chamber and fed regeneratively via channels 574 through a heat exchanger through fiber spooler 570 to pre-heat the working fluid before entry into the working fluid injection ports 576 into a gas expansion chamber. Importantly, the output of spooler 570 goes through an optional coupler 578 and is then connected to a laser injection interface structure 580 by fiber 582 where it proceeds through beam forming optics 584, 586.

There are two general approaches available at this point to create thrust, both of them efficient. In the first idea the beam forming optics 586 focus the beam 588 of laser energy through a laser window 590 on the back side of the expansion chamber and bring the beam to a point inside the gas expansion chamber, creating a stable plasma 592. Working fluid enters the chamber via port 576 or other entry means. As the gas enters the chamber it is preheated in the focusing zone 594 and begins to expand, passing around the central plasma via path 596. A convective mixing zone 598 exists beyond the plasma centroid and at this point the hot, expanded gas passes through nozzle throat 600, through high temperature expansion nozzle 602 and creates thrust 604. Alternatively, plasma core 592 can be replaced by a series of heat exchangers where an expanded (as opposed to focused) beam impinges, with all other facets remaining the same. The reaction chamber minimizes radiative heat loss through the chamber walls 606.

The working fluid can be from several sources. During initial flight through the atmosphere a ram air scoop 608 in the open position on the side of the vehicle, allows atmospheric air 610 to be compressed and taken into the vehicle. This can then be sent through a ram air intake structure 612 and through flow selector means 614, and through bypass valves 616. Bypass valves 616 can optionally send the working fluid to the heat exchanger located in the fiber spooler 570 for preheating to improve the efficiency of use of all heat being delivered to the vehicle via the fiber laser power system. At approximately twenty to thirty kilometers altitude the atmosphere will be too thin to provide effective quantities of fluid to be expanded to create thrust. A gradual transition will take place, where working fluid may be drawn both from the atmosphere as well as from the chamber 572. Eventually, at sufficient altitude, classed as "exo-atmospheric" flight, the vehicle 562 will need to rely solely on stored onboard propellant. Chamber 572 carries that exo-atmospheric working fluid, which is preferably one of liquid hydrogen, liquid nitrogen or other liquefied gas, but alternatively could be a stable fluid such as water. The logic for using the latter is that the most logical micro payload (the class of launch vehicle most likely to be powered by this concept in the one to one-hundred kilogram payload range) is in fact water because it is a dense, acceleration-insensitive material that is of great demand in LEO. Other payloads might include dense consumables and acceleration resistant electronics, sensors, and other high-technology re-supply items that may be needed in LEO. The working fluid contained in chamber 572 can be forced into the expansion chamber by several means, including vehicle acceleration; an optional turbopump 616; or an optional gas blow down system 618 that utilizes an inert pressurized gas to force the fluid through channel 620 to the reaction chamber.

The length of optical fiber needed to achieve orbit is variable, as the launch vehicle can carry an independent small propulsion system for final orbital insertion. From a practical



standpoint, however, a fiber length on the order of one-hundred kilometers could be considered a limiting value as attenuation along the length of the fiber will eventually reduce the effective power received at the vehicle. During the highly energetic initial phase of the launch a properly designed vehicle should be able to make use of the majority of the heat delivered as the power loss over the fiber deployed behind the vehicle will be small. Regenerative pre-heating of the working fluid, using channels 574, represents one of several means for extracting heat both from the coherent element of the delivered laser energy (via the beam focusing optics) and from the power dissipated in the fiber spooler 570. The spooler 570 could advantageously be placed within the working fluid flow path or reservoir prior to the fluid being injected into the optically heated expansion cavity 594. Both sources (coherent optical and non-coherent radiative heat from the spooler) will viably contribute to the overall thrust of the system.

Because the objective of fiber laser launch is to dramatically reduce the cost of placing a kilogram of payload into LEO, the vehicle design must be as efficient as possible thus measures such as using the lightest weight materials for the vehicle structure and propulsion and guidance systems and striving for economy of scale are important. An important facet of economy will be that of fiber recovery. A one-hundred kilometer bare optical fiber will cost, in 2010 dollars, between twenty and thirty thousand dollars depending on its characteristics and core diameter. This price may be reduced significantly with large quantity purchases and improvements in long-fiber extrusion manufacturing techniques. Nonetheless, it will remain essential for commercial launch operations to reuse that fiber as many times as possible. A bare one-hundred kilometer fiber extended in a typical parabolic launch trajectory will take a substantial time to fall through the atmosphere (on the order of more than an hour from the highest point) owing to its small diameter and low descent terminal velocity. A large, servo-controlled drum spooler 622 can be used to engage the fiber immediately after launch and reel the fiber back in before it can hit the ground. The physics for this are well within the limits of current mechanical systems design and available materials. The drum spooler 622 is not used during launch; it is strictly used for retrieval of the fiber after launch and does not engage nor wrap any of the launch fiber until it has been fully spooled out by the launch vehicle. In the notional example shown in FIG. 18, the high power fiber 566 coming from the laser 518 can be advantageously latched to drum 622 at high energy connector 624, which mates to connector 626 which is rigidly affixed to drum 622. Following a launch, connector 626 can be disconnected from connector 624 and the drum 622 will be free to begin the fiber retrieval process. With proper design the fiber can be post-processed, cleaned, and re-wound for a subsequent series of launches.

FIG. 19 shows an embodiment in which one or more fiber spooler assemblies 628 reside on the centerline of the launch vehicle. The fiber 630 connected to the laser source not shown is protected by fiber guide 632, which protects the fiber 630 from direct thruster plume impingement that might otherwise damage the fiber 630. The fiber 634 from the inboard side of the fiber spooler 620 connects to high power fast rotary beam switch assembly 636 at its centerline. The beam is expanded through optical system 638 whereupon the beam impinges on mirror 640 at the switch centerline. Servo motor 642 is connected to a high speed, high stiffness rotary shaft 644, the rotational position of which is sensed by embedded rotational encoders. The rotation of shaft 644 causes high speed indexed rotary mirror 640 to direct the coherent laser energy to a

plurality of fixed, static mirrors 646 arrayed radially around the central mirror 640. When the beam is directed to mirror 646, it causes the laser energy 648 to be deflected to beam focusing optics 650, which in turn inject the beam into coupler 652 for subsequent transmission to thruster 654. If mirror 640 is subsequently rotated until it aligns with high energy fixed mirror 656, the beam is then diverted to exit fiber 658, which carries the optical energy to thruster assembly 660. The light enters thruster assembly 660 via laser optics cavity 662, where the beam is either focused or defocused as previously discussed (with reference to FIG. 18) for the purpose of optimal heating of heat exchanger or plasma cavity 664. Working fluid 666 enters heat exchanger 664 and is subsequently heated, and expanded through nozzle 668 to create thrust 670. In this fashion any number of axially centered fiber spoolers can deliver power to a radial array of thrusters. Advantageously, as will be described below, three or more thrusters equally distributed radially (for example, three thrusters would have one-hundred twenty degrees of angular spacing between them relative to the launch vehicle centerline) allow for a significant simplification of the vehicle while still enabling full thrust vector control during launch.

Thrusters 654, 660 are advantageously canted at a desired divergence angle 672 from centerline so as to further reduce the possibility of impingement of the exhaust plume from these thrusters with the trailing fiber. Further, by canting the thrusters 654, 660 and using three or more thrusters, it is possible to achieve active thrust vectoring of the launch vehicle with no moving parts associated with the thrusters 654, 660. The beam switch 636 is capable of rapidly transferring power to a specific thruster based on a desired vehicle direction. For direct, straight ascent, the laser is rapidly shifted between thrusters so that all thrusters receive equal amounts of power and therefore each nominally produces symmetric thrust and the vehicle will maintain the instant tangent trajectory that it was on. However, even with dissimilar (or physically identical but variably performing) thrusters, an onboard computer control system can rapidly generate a real-time vehicle state vector matrix and from that determine which thruster to favor in order to divert the vehicle to the desired trajectory.

FIG. 20 shows another preferred embodiment of the fiber laser launch concept. In this variant, a plurality of fiber spoolers 674 arrayed in a radial fashion about the centerline of the vehicle and delivering power to a series of laser injection systems 676. A high energy bare fiber 678 trails behind the vehicle during launch and connects to a ground-based laser (not shown). Fiber guides 680 protect the trailing fibers from direct exhaust plume impingement from the thruster. The spoolers 674 are connected via fiber 682 to actively cooled high power couplers 684, which inject the beam into the laser optics cavity 686 via laser injection assemblies 676. Beam forming optics 687 contained in each injection assembly 676 are independently controlled in real-time to provide either a focused or diffuse output into the heat exchanger or plasma zone 688 at the core of the optics cavity wherein a working fluid, injected at port 690 is superheated and expands through expansion nozzle 692 to create thrust 694. In this embodiment, one or more thrusters 696 are centrally located either on centerline or arrayed symmetrically, radially, or otherwise about the vehicle centerline so as to create a central thrust capability. One or more of these thrusters may be additionally gimbaled so that its thrust vector can be modified under real-time computer control to maintain the vehicle on a desired ascent trajectory.

Notably, hybrid variants of the inventions described in FIGS. 18-20 are possible in which fast beam switches and

beam splitters are used to combine many laser inputs and channel them to many thruster outputs. These techniques can be used to boost larger payloads. Telemetry from the vehicle to the ground, or conversely from radar tracking of the ascent vehicle, can be used to determine the instant state vector for the launch vehicle. This can be used as the basis of corrective algorithms for steering the vehicle back to a correct course. The vehicle can optionally have onboard a navigation system consisting of either purely inertial sensors, a GPS (global positioning system) receiver, or other methods for estimating the position of the vehicle at any point in time and that information can be sent back in real-time to a mission control computer either via radio (RF) telemetry or via modulated data signal superimposed on the laser power transmission fiber. This technique advantageously eliminates several systems from the mass of the launch vehicle and it allows for direct non-line-of-sight communications to the vehicle, possibly for over-ride of the on board trajectory control or for range-safety termination of the launch.

Another variation on fiber laser launch is that of an intelligent autonomous battlefield delivery system. This is far more effective than, e.g., a GPS-guided artillery shell for several reasons. First, the range for a laser-powered payload is in excess of one-hundred kilometers and more likely on the order of two-hundred kilometers given that realistic fiber spoolers can be up to one-hundred kilometers long and, if the payload separates at apogee, then it will ballistically coast approximately that same distance. However, up until the point of fiber separation it will be possible, again via modulated data on the power fiber, or on a dedicated separately spooled fiber, to communicate with the payload and to cause it to be re-directed. A forward scouting team could provide such a system with real-time GPS coordinates (even if moving), which could be uploaded to the payload for real-time re-targeting. Further, there is no requirement for a maximum thrust flight nor for a ballistic trajectory. The fiber laser launch concept permits flight down to minimum stable flight speed as well as “loitering” in a vicinity—made possible because the power source is continuous and substantial, and located at a rear base of operations. This means that the flight vehicle’s dwell (or “loiter”) time in an area of operations could be made indefinite and the vehicle would not be required to carry with it any fuel (because at low altitude, atmospheric air can be the “working fluid” for propulsion). Because the flight speed can be made variable, and arbitrarily low if needed, sensitive supplies could also be sent to a forward operations team (human) with precision delivery capability.

FIG. 21 shows another variation of the invention in which a rotary beam switch 698 is placed between the laser source 518 and an array of two or more spoolers 700, 702. These spoolers 700 are advantageously located on docking ports adjacent the central power supply and laser facility 704 such that a mobile autonomous vehicle 706 could return automatically following a mission (after having expended its one-use spooler) and dock with a port containing a full spooler. At that point the vehicle 706 could re-load a fresh spooler by removing it from the docking port and latching it onto a receiver port on the mobility system 708, thus re-enabling it for another mission.

As an example, the mobility system 708 would begin a mission using fiber spooler 700 which, as previously explained, is connected to a power conversion system 710, which generates electrical power or alternative power to cause the mobility system 708 to move. At the conclusion of a mission, mobility system 708 returns to the central power laser source 704 and discards spooler 702 and, while operating on residual onboard electrical power storage systems,

moves to the docking port that contains a second spooler 700. It then acquires that spooler 700, connects to it, and notifies the laser that power can now be transmitted through that spooler. The main computer system at the laser source 704 then causes beam switch 698 to re-route the laser energy to the port that connects the power to spooler 700 with fiber 712. This is a viable multi-mission-enabling design that permits re-load of a single vehicle (e.g., a planetary robotic exploration vehicle returning to a lander) for subsequent missions while maintaining the heavy elements of the system (power source and laser) on the lander. However, this same approach can also be used to sequentially send power to a plurality of mobility systems (e.g., autonomous ground vehicles on a battlefield or forming a defensive perimeter around a forward base of operations).

FIG. 22 presents another embodiment in which a remote mobility system 714 (which will be explained within the context of an unmanned aerial vehicle but it could also be an unmanned ground vehicle system, underwater system, or a manned variant of any of those) again receives coherent laser energy, generated by a forward base power system 716 comprising a power generation system 516 and a laser cooling system 564 connected by cooling and power delivery channels to a high power fiber laser 518; high power delivery fiber 566 and leading to fiber coupler 568. Bare fiber 718 from an on-vehicle spooler 720 trails out through fiber pay-out guard 722, which prevents the trailing fiber 718 from being damaged by vehicle locomotion means. The fiber spooler 720 contains, as previously described, a spool 724 (precision-wound axial for aerial operations and drum-spool wound for ground and underwater applications, preferably); an actively cooled heat exchanger 726; a passive heat radiator 728, and a high power fiber coupler 730 that connects the spooler 720 in a modular fashion to the vehicle.

In this embodiment, the primary power of the laser 518 is intended for industrial or military purposes and the output of the fiber spooler 720 is connected by output fiber 731 to a laser targeting ball 732. The targeting ball 732 contains a real-time active beam focusing structure 734 that contains a diverging lens means 736 and a real-time variable range focusing lens means 738, which causes high energy beam 740 to pass through optional laser window 742 and to be focused at a point 744 beyond the vehicle that is to be determined by other sensors onboard the vehicle. The vehicle carries an auxiliary power unit (APU) 746 that provides dedicated power to cooling system 748 that maintains the fiber spooler 720 within its optimal operating temperature range throughout a mission. Two parallel fibers to this vehicle: one carrying optical power for direct use by the laser targeting ball 732 and a second one for use in powering the locomotion of the mobility platform.

FIG. 23 shows an unmanned aerial vehicle 750 comprising of primary wing structures 752; stabilizer fins 754; propulsion air intake 756; and propulsion unit 758. The vehicle 750 is retrofitted with a lower stabilizer fin 760 towards the rear of the vehicle 750 that serves as a mounting post for high power fiber spooler 762. The fiber spooler 762, as previously described, is equipped with a fiber pay-out guard 764 that prevents the trailing fiber 766 from being interfered or damaged by the propulsion unit 758. The fiber 766 from spooler 760 leads forward through the fuselage of the UAV 750 where it connects to laser head 768. Beam focusing optics cause laser radiation 770 to focus on point 771 external to the vehicle 750. The vehicle 750 is assumed to be equipped with a reconnaissance, surveillance, and target acquisition (RSTA) ball 772, which surveys the field of action using a variety of sensing technologies and conveys that information to

onboard avionics control and targeting system 774. The targeting system, in turn, causes the laser targeting ball 768 to lock its orientation in real-time to the target point 771 designated by the RSTA ball 772. Feedback between these two systems can be used to actively re-target beam 770 in real-time pending live assessment by RSTA ball 772. While the vehicle 750 disclosed in FIG. 23 is largely a battlefield device, the same components installed in an autonomous underwater vehicle could be used effectively for removal of obsolete oil production platforms (by offering a precise means of cutting off large tubular steel column elements) without the need for dangerous commercial human diving operations, which is presently the rule for such work.

The present invention is described in terms of a preferred illustrative embodiment and alternative embodiments of specifically-described apparatuses and systems. Those skilled in the art will recognize that yet other alternative embodiments of such apparatus and systems can be used in carrying out the present invention. Other aspects, features, and advantages of the present invention may be obtained from a study of this disclosure and the drawings, along with the appended claims.

We claim:

1. An optical power transfer system comprising:
  - an actively cooled fiber spooler made up of a high thermal conductivity material;
  - a length of fiber for transmission of high optical energy, said length of fiber circumscribing at least part of said fiber spooler;
  - a remote mobile platform;
  - at least one high power optical coupler having a first end and a second end, said first end of said at least one high power optical coupler connected to said length of fiber and said second end of at least one high power optical coupler connected to said remote mobile platform; and
  - a power extraction subsystem on said remote mobile platform, said power extraction subsystem having an optical energy input for receiving high optical energy, said optical energy input connected to said length of fiber,
  - a refractory beam dump having a cavity and at least one heat exchanger channel,
  - a refractory target within said cavity,
  - beam forming optics orientated to receive said high optical energy from said optical energy input and direct the received said high optical energy to said refractory target;
  - an array of thermoelectric converters, said thermoelectric converters having an interior side and an exterior side, said interior side connected to said refractory beam dump and said exterior side exposed to a cold environment creating a temperature gradient; and
  - wherein said high optical energy is converted to another form of energy usable by said remote mobile platform.
2. The system of claim 1 wherein said fiber spooler comprises:
  - a housing having a longitudinal axis, a housing sidewall, an external sidewall surface, and an internal sidewall surface;
  - at least one mandrel radially within said housing having a mandrel sidewall, said mandrel sidewall and said housing sidewall defining an annular fiber feed channel there-

- between, said at least one mandrel having at least one winding surface defining at least one circumferential groove, said mandrel sidewall having at least one circumferential channel formed therein;
  - an active cooling system having a coolant inlet and a coolant outlet, both in fluid communication with said at least one circumferential channel; and
  - a plurality of panels protruding radially outwardly from said external sidewall surface of said housing.
3. The system of claim 2 further comprising a portion of said length of fiber at least partially wound around said at least one winding surface of said at least one mandrel.
  4. The system of claim 3 further comprising a thermally conductive adhesive coating between said at least one winding surface and said portion of said length of fiber.
  5. The system of claim 2 wherein said at least one mandrel further comprises at least one coolant duct disposed circumferentially around said housing sidewall.
  6. The system of claim 2 wherein said at least one mandrel has rounded internal and external trailing edges.
  7. The system of claim 2 further comprising a layer of thermally absorbing coating on said housing sidewall.
  8. The system of claim 3 further comprising a high thermal conductivity adhesive releasably adhering said portion of said length of fiber to said internal sidewall surface of said housing.
  9. The system of claim 1 wherein said actively cooled fiber spooler further comprises:
    - a mount;
    - a drum having a cylindrical drum body and a longitudinal axis, said drum rotatably connected to said mount and having a longitudinal axis;
    - at least one fluid channel extending through said drum body; and
    - wherein said length of fiber is at least partially wound around said drum.
  10. The system of claim 3 wherein said portion of said length of fiber is pretwisted to prevent hockling.
  11. The optical power transfer system of claim 1 wherein said refractory target is an array of photovoltaic cells tuned to generate electricity at the wavelength of the received said high optical energy.
  12. The optical power transfer system of claim 3 wherein said winding surface of said at least one mandrel is smooth.
  13. The optical power transfer system of claim 12 wherein said at least one mandrel is slightly tapered along its longitudinal axis such that the diameter of said at least one mandrel at the fiber releasing end is less than the diameter of the opposite end of said at least one mandrel.
  14. The optical power transfer system of claim 13, wherein said length of fiber releasably adheres to said smooth winding surface by a thermally conducting adhesive and wherein in the adhered configuration, adjacent fibers do not touch.
  15. The optical power transfer system of claim 2, wherein said actively cooled fiber spooler is mounted at a remote location.
  16. The system of claim 15 wherein said length of fiber is pulled out linearly in a direction parallel to the center axis of said at least one mandrel.
  17. The system of claim 1 wherein said high optical power is in the range of kilowatts to tens of megawatts.

\* \* \* \* \*