



Development and Certification of a System for the Controlled Deployment of Micro-satellite Payloads from the International Space Station

2015 NASA Young Professionals Forum for Structures, Loads & Mechanical Systems (SLaMS)

September 2015

Matthew P. Hershey

Mechanical Design & Analysis Branch
Structural Engineering Division
NASA Johnson Space Center

Agenda



- Project Overview
 - Introduction: The State of the Art
 - The Cyclops System
 - Concept of Operations
 - Progression of Roles: Concept to Operation
- Design of Retention & Release Mechanism
- First Successful Mission: SpinSat Deployment
- Forward Work
 - On-going Challenges
 - Upcoming Payloads



Project Overview

Introduction: The State of the Art



Utilization of the International Space Station (ISS) by satellites:

- The idea of precisely and safely launching satellites into orbit from the ISS has become increasingly popular in recent years.
- Two CubeSat Launchers are currently in aboard the ISS. However, for satellites larger than the standard 10 cm³ CubeSat size, no solution existed prior to Cyclops.



CubeSats deployed from the ISS

Expanding the ISS deployment capability:

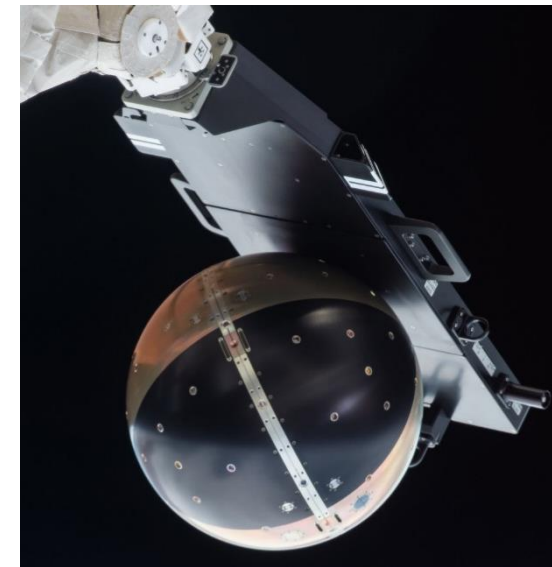
- The reusable “Cyclops” deployment system was designed and built to serve the needs of larger, heavier payloads of miscellaneous shapes seeking to take advantage of the unique logistical opportunities offered by the ISS to the satellite developer community.



LoneStar
(planned for 2015)



Terrestrial Return Vehicle
(planned for 2016)



SpinSat
(deployed Nov. 2014)

The Cyclops System

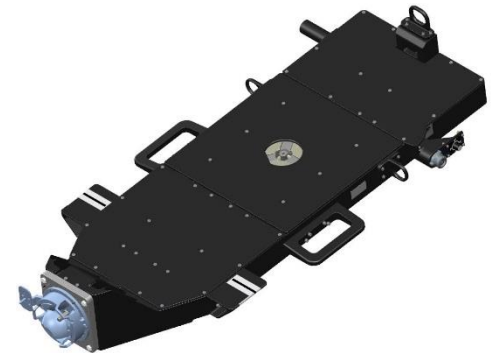


Space Station Integrated Kinetic Launcher for Orbital Payload Systems (SSIKLOPS), a.k.a. Cyclops:

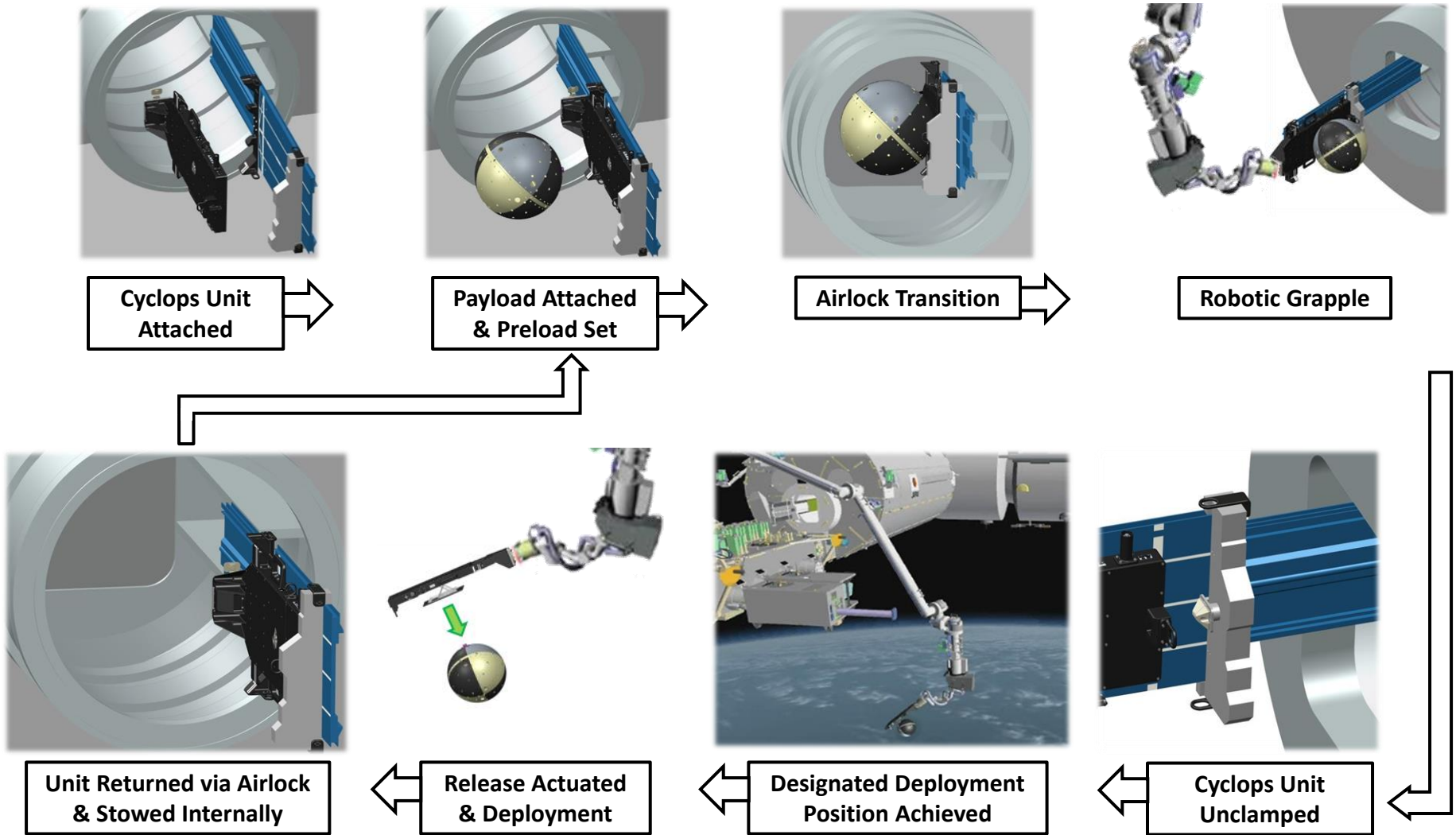
- Cyclops provides a method for transferring large, internally-stowed experiments featuring a wide variety of shapes to the extravehicular environment, followed by deployment.
- Its a reusable, on-orbit ISS facility that can be utilized by satellite developers easily and cost effectively.
- There are currently no launch or deployment costs for Cyclops users, and the required Cyclops experiment attachment fixture (EAF) is provided by the ISS Program upon request by payload developers.

Specifications of the Cyclops Unit:

- Cyclops requires no electrical power and provides all the necessary interfaces for crew, for the Airlock slide table and for the ISS robotic arms.
- It uses only mechanical components, taking advantage of only torque provided at the robotic interface. It constrains the satellite throughout the mission and performs a safe, reliable deployment maneuver at the designated EVR location.
- Primary internal subsystems:
 - Transmission system
 - Retention and Release Mechanism
 - Safety Lockout Mechanism
 - Jettison Spring Preload system



Concept of Operations

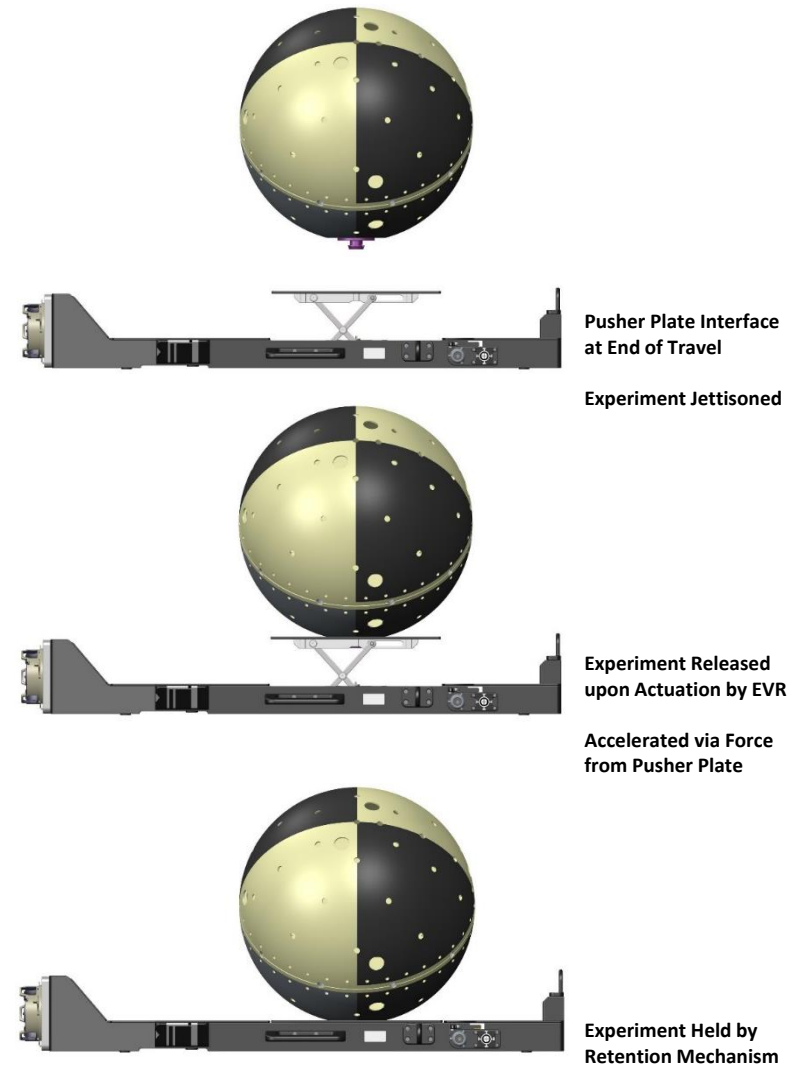


Concept of Operations

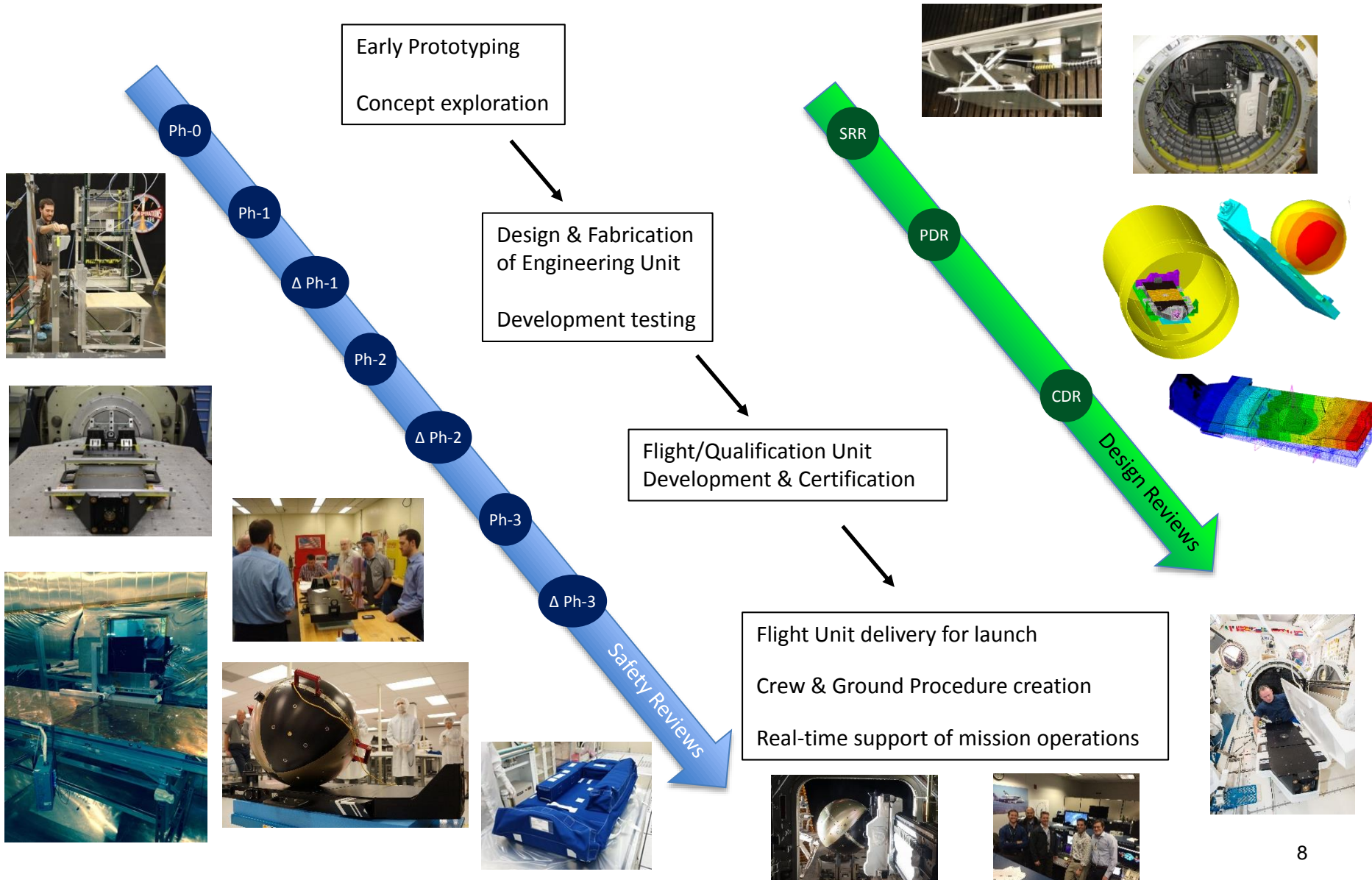


Illustration of a Payload Deployment by Cyclops

- The figure to the right is an example of the deployment of a payload, generically showing how Cyclops performs a jettison.
- Cyclops control the deployment direction and provides the required deployment velocity for safe separation from ISS, within the anticipated release cone.
- After deployment, and upon reaching a predetermined safe distance from ISS, the deployed payload begins its operations as an independent small satellite orbiting the Earth.



Progression: Concept to Operation





Design of Retention & Release Mechanism (RRM)

Excerpt of Work from the Cyclops Flight
Unit Development Phase

Retention and Release Mechanism



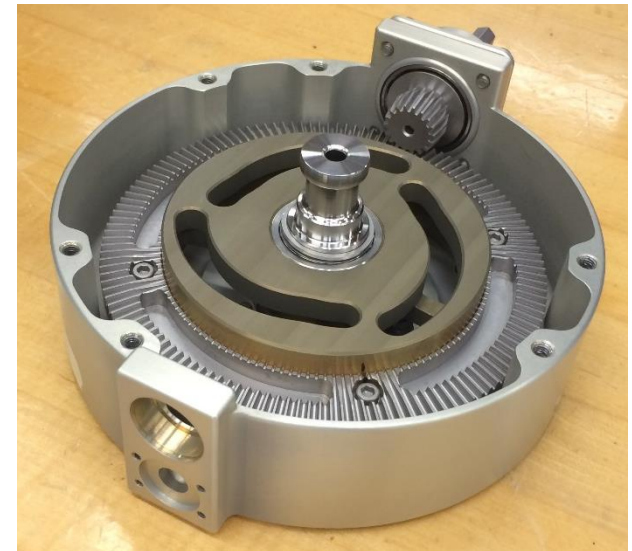
Example of One of My Roles in the SSIKLOPS Project: Lead for the Design of the RRM

Function:

1. provide Cyclops with the ability to retain payloads during translation phases while they're preloaded against the deployment system, and
2. release a retained payload at the deployment site in such a way that it departs with minimal roll and minimal angle offset from the target deployment vector

Priorities Driving the Design:

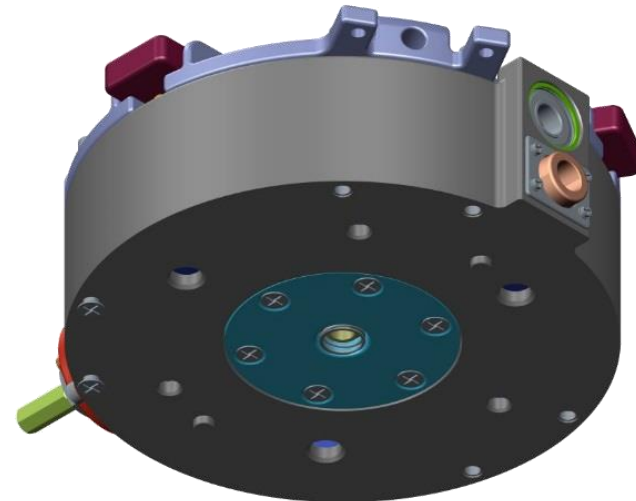
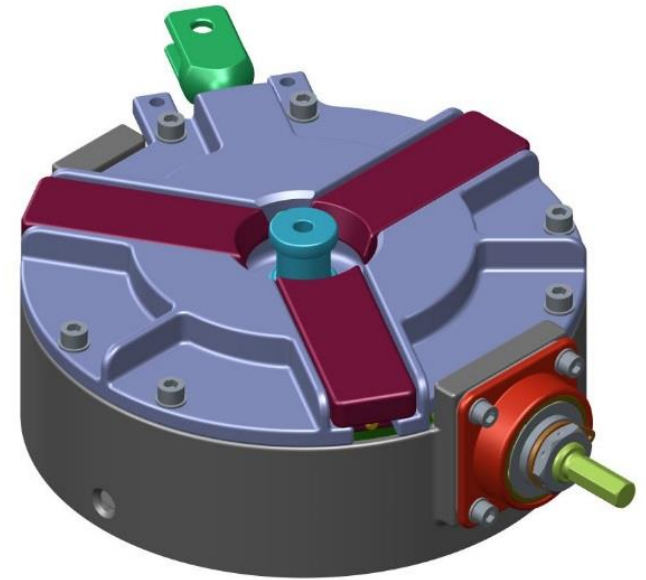
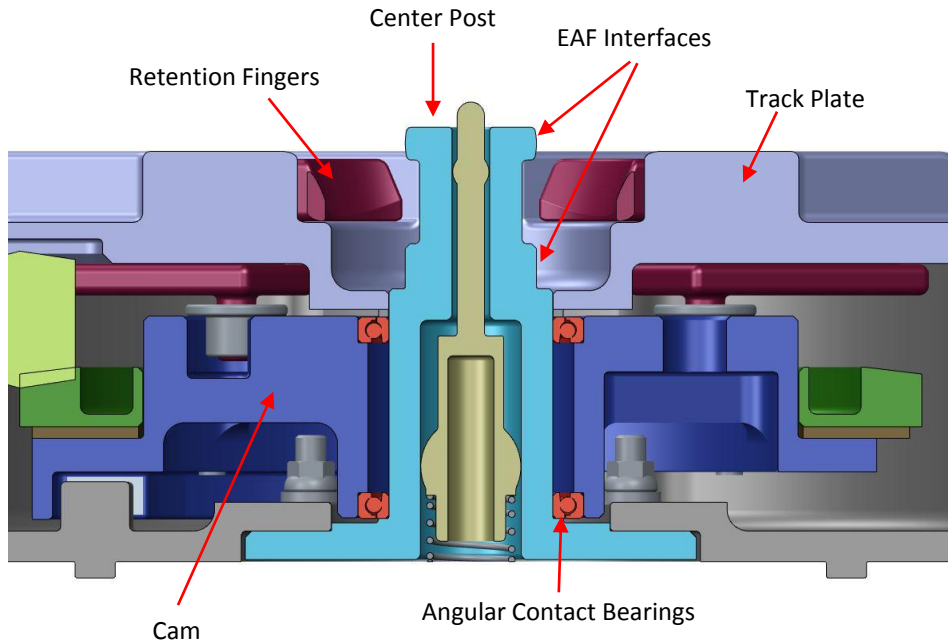
- Characterize mechanism function & trade selection
- Selection of constraints, component Degrees of Freedom, load paths
- Clearance Management and Tolerance Analysis
- Understanding of manufacturing methods and oversight over assembly processes for flight hardware
 - Drawings to serve as unambiguous and repeatable guide for the fabrication of the Flight Unit and Qualification Unit
- Provides a means of addressing catastrophic hazards associated with the mechanism function, namely inadvertent payload release
- Provide a means of positive indication of status for the retention of the payload, prior to translation outside the ISS via the JEM Airlock



Retention and Release Mechanism



Primary Components:

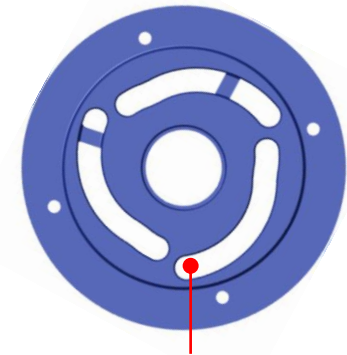
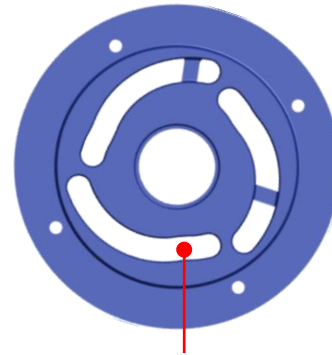
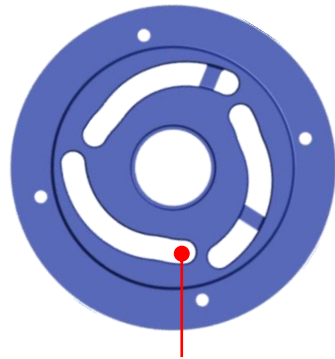


Retention and Release Mechanism



Release Function:

- Cam rotates forcing the Fingers closed/open
- The Fingers (3) overlap the EAF for a structural connection
- The Fingers open in an excessive fashion to ensure a clean release in the presence of tilting and lateral shifts
- Feature sizes ensure no Finger to EAF interference at the Cam on-center position



Experiment
Interface
Surface

Experiment
Attachment
Fixture (EAF)

Cam Closed and Over-Center
Min Finger to EAF Overlap

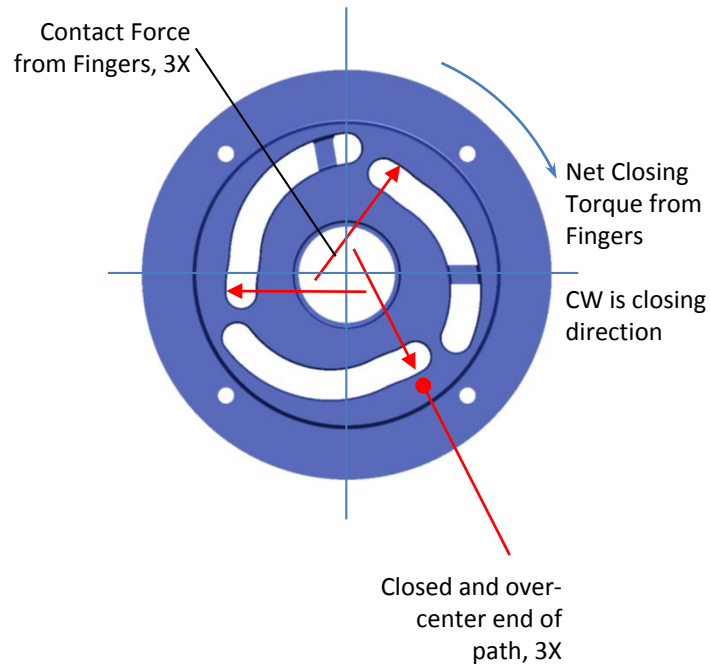
Cam Moved to On-Center
Fingers Drive Inward
Max Finger to EAF Overlap

Cam Moved to Open

Retention and Release Mechanism



Protection Against Inadvertent Release:

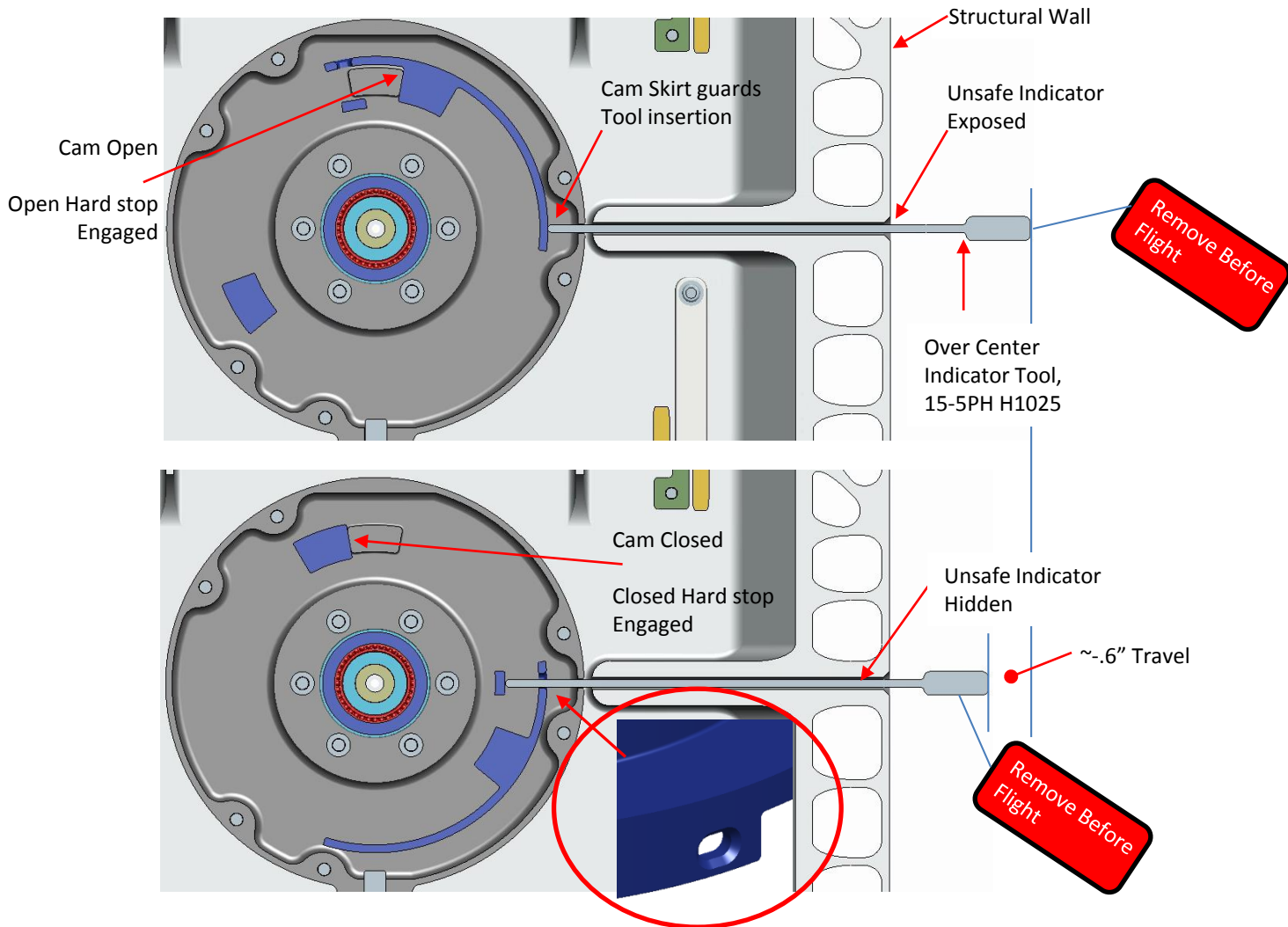


- Cam path has an over-center well to prevent inadvertent EAF release
- Force from the bias open springs and external loads force the cam CW towards the closed position
- This over center behavior allows the mechanism to act as structure
- Open Bias springs force Fingers outward
- Bias Philosophy:
 - Ensures Cam's over-center position when closed
 - Promotes EAF release during opening

Retention and Release Mech (cont)



End of Travel Stops & Positive Indication of Over-Center Status:





Deployment of SpinSat

Cyclops' First Mission

Successful Deployment of SpinSat



- Cyclops and SpinSat were launched on SpaceX CRS-4 on September 21st, 2014 and delivered to the ISS on September 23rd, 2014.
- On November 28th, 2014, at 14:30 UTC (08:30 CST), Cyclops successfully deployed the SpinSat satellite from the ISS into orbit.
- Below is a photograph taken by the crew inside of the JEM showing the SpinSat installed on Cyclops, after Cyclops had been mounted to the JEM Airlock Slide Table.



Successful Deployment of SpinSat



- Photographs taken by the crew aboard the ISS depict SpinSat moments before and after it had been deployed by Cyclops at the end of the JEM Small Fine Arm.
- Initial satellite tracking determined that the SpinSat departed at a velocity of about 0.18 m/s and reached its planned safe distance from the ISS.
- The U.S. Naval Research Laboratory (NRL) successfully established communication with SpinSat shortly afterwards. Its primary purpose is to serve as an electronically-controlled Solid Propellant thruster, atmospheric neutral density experiment.



Successful Deployment of SpinSat



Video Credit: NASA JSC Public Affairs Office



Forward Work

On-going Challenges



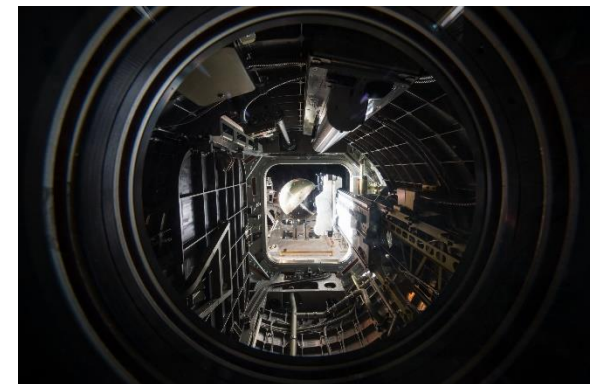
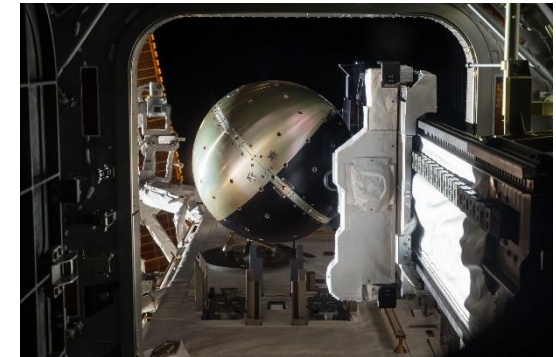
- Crew time constraints:

- To maximize ISS Utilization, savings on IVA crew time are sought throughout all operations aboard the ISS.
- All regular activities are under pressure become more efficient, by either shortening time for tasks or by requiring fewer crew members. This includes Cyclops pre-deployment operations performed by crew within the JEM.



- JEM Airlock traffic limitations:

- Uses for the small payload airlock within the JEM have only grown since JAXA began deploying CubeSat with their J-SSOD launcher, including Nanoracks payloads, the Amonia Leak Locator, the JOTI system for transferring orbital replacement units (ORU's), among many others.
- Due to the JEM Airlock life-cycle and certification limitations, there are fewer rides out the airlock than there are requests.
- While engineers in the ISS program are actively seeking solutions, there is little that can be done by the payload developers themselves.



Upcoming Payloads

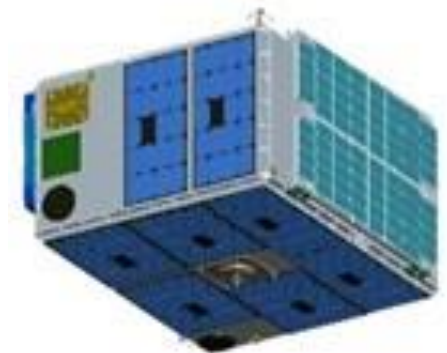


- Manifested for launch:

- LoneStar (University of Texas in Austin, Texas A&M University, JSC Engineering Directorate)
- Terrestrial Return Vehicle (Intuitive Machines in Houston, TX)
- STP-Sat4 (Department of Defense Space Test Program)



LoneStar (late 2015)



STP-Sat4 (2016)

- Potential future users:

- MDX (Kentucky Space)
- RED-4U (Terminal Velocity Aerospace)
- M-SAT satellites (Missouri University of Science & Technology)
- Recurring STP-Sat's, TRV's, MDX's and RED-4U's



Terrestrial Return Vehicle (2016)



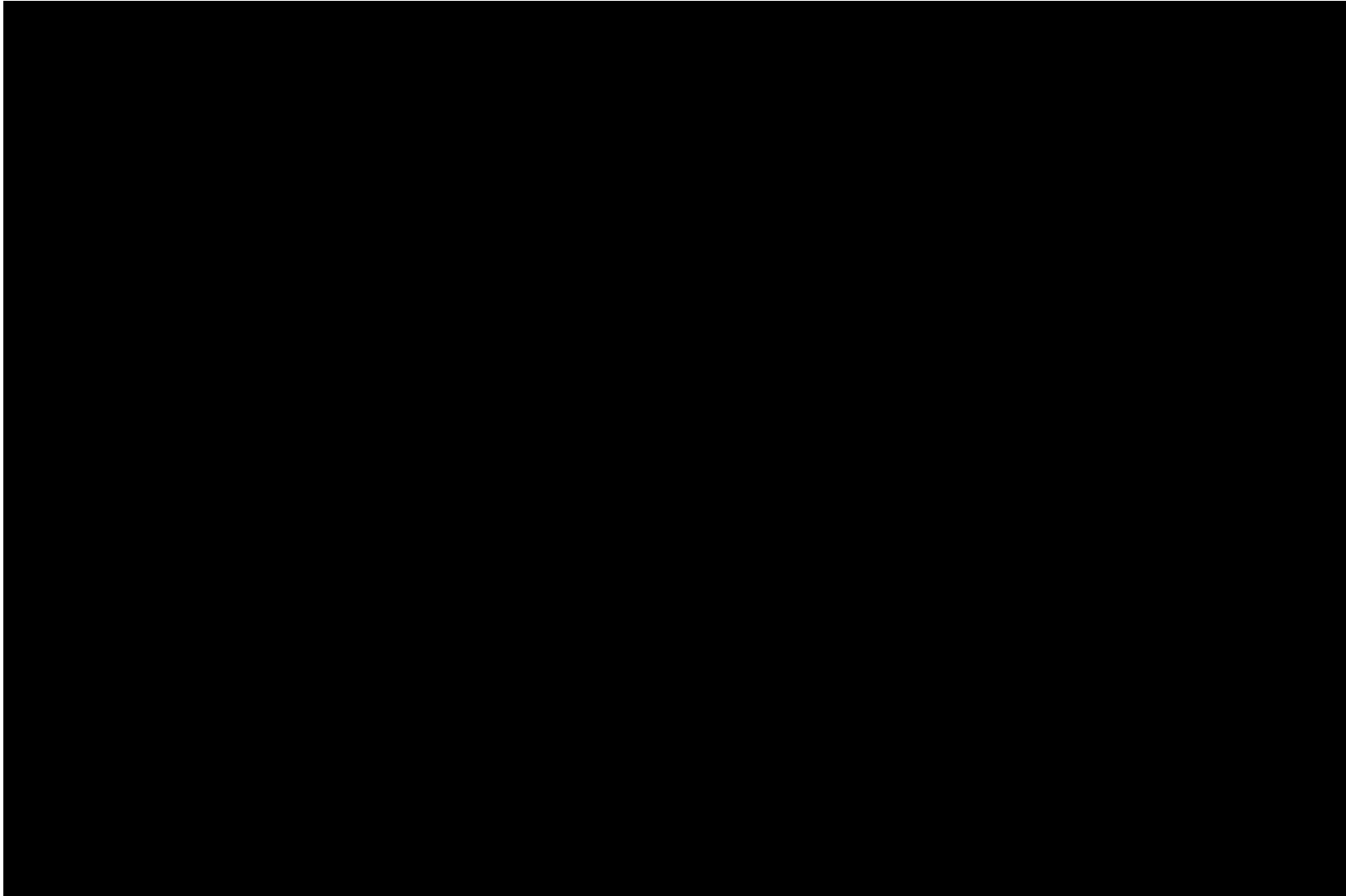
Q & A





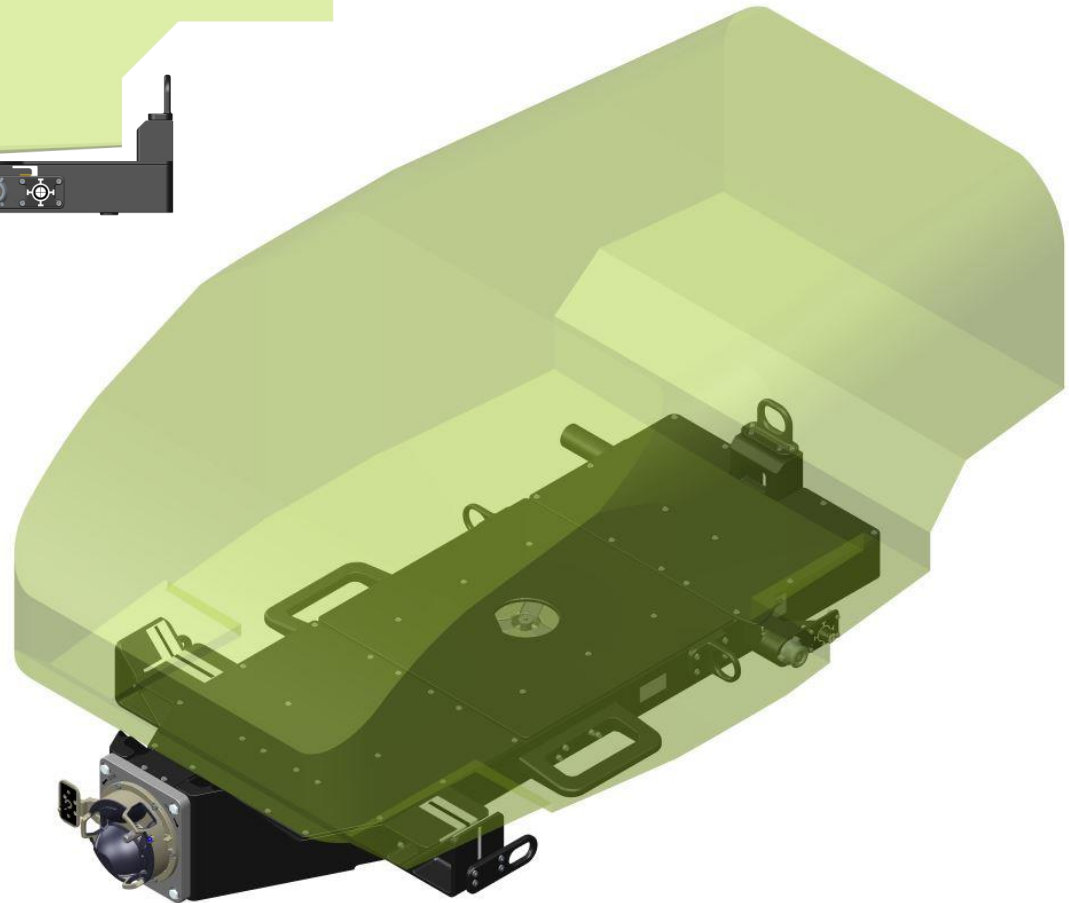
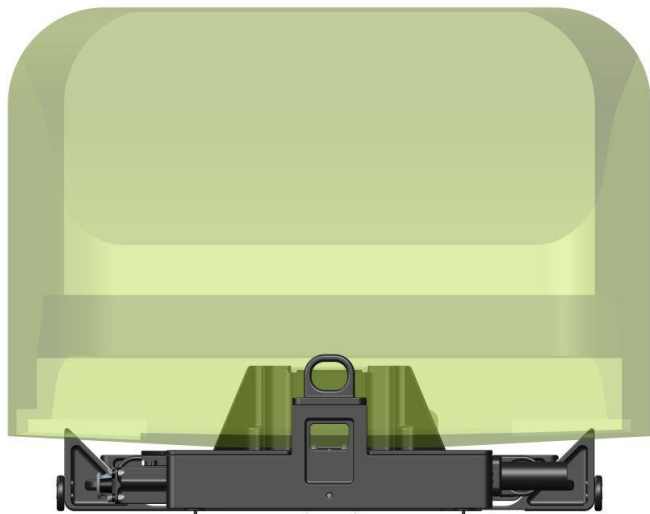
Back-up

JAXA Deployment Animation



Video Credit: JAXA

Size Envelope for Cyclops Users



Cyclops Interface for Payloads

