

# Advancing the Oxygen Generation Assembly Design to Increase Reliability and Reduce Costs for a Future Long Duration Mission

Kevin C. Takada<sup>1</sup>

*NASA, Marshall Space Flight Center, Huntsville, AL, 35812, USA*

Ahmed E. Ghariani<sup>2</sup>

*GeoControl Systems, Inc., Houston, TX, 77087*

*and*

Steven Van Keuren<sup>3</sup>

*Anadarko Industries, L.L.C., Houston, TX, 77058, USA*

The state-of-the-art Oxygen Generation Assembly (OGA) has been reliably producing breathing oxygen for the crew aboard the International Space Station (ISS) for over eight years. Lessons learned from operating the ISS OGA have led to proposing incremental improvements to advance the baseline design for use in a future long duration mission. These improvements are intended to reduce system weight, crew maintenance time and resupply mass from Earth while increasing reliability. The proposed improvements include replacing the cell stack membrane material, deleting the nitrogen purge equipment, replacing the hydrogen sensors, deleting the wastewater interface, replacing the hydrogen dome and redesigning the cell stack power supply. The development work to date will be discussed and forward work will be outlined. Additionally, a redesigned system architecture will be proposed.

## Nomenclature

ECLSS	=	Environmental Control and Life Support Systems
EVA	=	Extra Vehicular Activity
ISS	=	International Space Station
LFL	=	Lower Flammability Limit
NASA	=	National Aeronautics and Space Administration
OGA	=	Oxygen Generation Assembly
OGS	=	Oxygen Generation System
ORU	=	Orbital Replacement Unit
PSM	=	Power Supply Module
RSA	=	Rotary Separator Accumulator
SOA	=	State of the Art

---

<sup>1</sup> Aerospace Engineer, Space Systems Dept., NASA-MSFC/ES62.

<sup>2</sup> OGS Subsystem Manager, Life Support Systems Branch, Mail Code EC3.

<sup>3</sup> ECLS Systems SME, BETS Contract, 91-51 MC HB2-30.

## I. History of the ISS OGA

AFTER more than a decade of development, the U.S. Regenerative (Regen) Environmental Control and Life Support Systems' (ECLSS) Oxygen Generation System (OGS) rack delivery was accelerated, and it was launched within the Shuttle cargo bay to the International Space Station (ISS) in July 2006 and installed in the US Laboratory (Lab) Module. The integrated Regen ECLSS three rack systems (see diagram in Figure 1) also include the Water Recovery System, comprised of the Water Processor Assembly (WPA) and the Urine Processor Assembly (UPA) which launched later in 2008 and together, enabled the ISS to expand its crew size from three to six crewmembers.

All three Regen ECLSS racks were originally intended to be installed in ISS Node 3, but the ISS program management desired an early check-out of Regen systems within US Lab prior to the Node 3 launch on Shuttle flight 20A. Regen rack modification kits were launched and installed within the US Lab in 2007 to provide the Regen systems' power, data, coolant, nitrogen, water, and space vacuum interfaces. The Regen ECLSS racks were subsequently relocated from the US Lab to Node 3 in February 2010.

The UPA distills the collected urine to evaporate and extract the water, which is fed into the WPA. The WPA combines the distillate with the humidity condensate collected from the ISS air conditioners into a waste water accumulator. The WPA system then purifies the waste water through resin based Multi Filtration Beds, Particulate Filters and a Catalytic Reactor before passing the recycled purified water through an Ion Exchange resin bed to release low levels of iodine as a microbial growth inhibitor. The WPA potable water is stored within an accumulator. The WPA provides potable water to the crew for consumption and the OGS for electrolysis.

The OGS rack (see Figure 4) includes the Oxygen Generation Assembly (OGA), Sabatier Carbon Dioxide Reduction Assembly (Sabatier CRA), the Power Supply Module (PSM), Avionics Air Assembly, Remote Power Controller Module, Rack Smoke Detector, Rack Power Switch, coldplates, flexhoses, power / data cabling, acoustic foam, and rack structure. The Sabatier CRA was launched separately and integrated into the OGS rack October 2010. The OGA utilizes cathode feed electrolysis to produce both oxygen for the crew to breathe, and hydrogen which is sent to the Sabatier CRA or optionally, out through the vent to space vacuum.

The Sabatier CRA utilizes a heated, catalyst reactor bed to combine hydrogen from the OGA and compressed carbon dioxide from the ISS Node 3 Carbon Dioxide Removal Assembly (CDRA) to produce water and methane. The separated methane gas is vented into space through the shared, OGA hydrogen / nitrogen sub-ambient vent line while the water is fed into the ISS wastewater bus for reprocessing through the WPA. The OGS rack contains accumulator tanks for compressed carbon dioxide storage. As of February 22, 2015 the Sabatier CRA has reclaimed over 1,000 lbm of water.

After a year of early checkout, the OGA was first activated for electrolysis in July 2007 by utilizing a temporary rack mounted Water Delivery System which pumped feedwater to the OGA from Payload Water Reservoirs containing shuttle fuel cell water. After the WPA and ISS Potable Water Bus were made operational in 2008, the OGS received Feedwater from the ISS potable bus and no longer required the WDS which was dismantled and stowed.

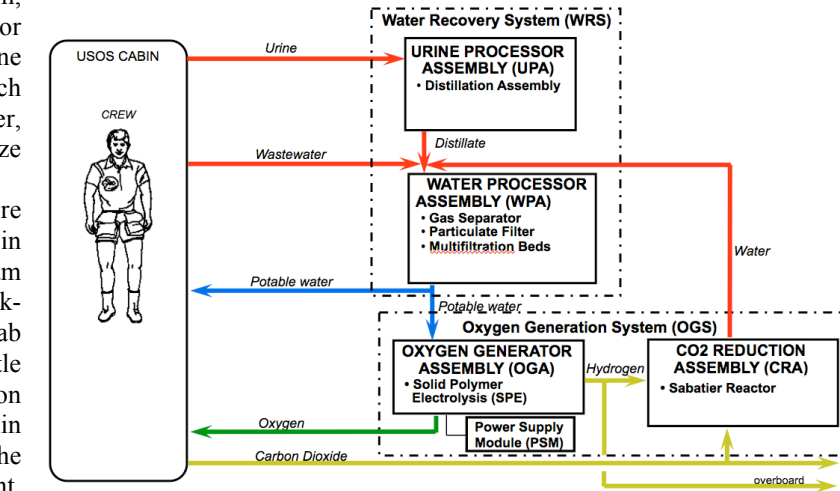


Figure 1 - ISS US Regen ECLSS Diagram.

## II. Description of the ISS OGA

As of March 1, 2015, the OGA has produced over 8200 lbm of oxygen and 1000 lbm of hydrogen. The OGA cell stack has accumulated a total operating time of 31,980 hours (including 133 hours of ground testing). See Figure 2 for a plot of oxygen produced over time.

A simplified schematic of the OGA is shown in Figure 3. Feed water from the ISS potable water bus enters the assembly through the Water Assembly Orbital Replacement Unit (ORU) and flows through an Inlet Deionizing Bed, which serves as an iodine remover and as a coalescer for any gas bubbles that may be present in the feedwater. If gas bubbles are detected by the gas sensor downstream of the DI bed, the feedwater is rejected by a three-way valve to the waste water bus. This serves to prevent any oxygen that may be present in the feedwater from mixing with the generated hydrogen. Water is electrolyzed into oxygen and hydrogen in the Hydrogen Dome ORU, which contains the electrolysis cell stack, sensors, valves and a Rotary Separator Accumulator (RSA). The RSA separates the cathode side product gaseous hydrogen from the water which is recirculated by the positive displacement Pump ORU. The hydrogen dome provides a multiple leakage barrier protection in the event of a failure. The hydrogen dome is maintained at low pressure by venting to space vacuum. Separated hydrogen gas is sent either to the Sabatier CRA or optionally out to space through the vacuum vent. Oxygen produced by the cell stack passes through the Oxygen Outlet ORU containing a water absorber, which protects the downstream hydrogen sensors from liquid moisture. The Hydrogen Sensor ORU monitors the product oxygen for the presence of hydrogen, which would indicate leakage within the cell stack and signal the OGA Process Controller to quickly shut down the OGA. The Nitrogen Purge ORU stores a pressurized volume of nitrogen gas from the ISS distribution line to purge the OGA cell stack upon shutdowns. Nitrogen is utilized to mitigate the safety hazards associated with the mixing of oxygen and hydrogen within the cell stack or the dome. The nitrogen can also be used to inert the dome environment during extended periods of non-operation. The Process Controller ORU is responsible for OGA system command/control and communication with the ISS. The OGA sensors are used for fault detection and fault isolation purposes. In addition, sensor data can be used to indicate that an ORU should be scheduled for changed-out with a pre-positioned, on-orbit spare ORU. The PSM ORU provides power to the OGA electrolysis cell stack. The PSM ORU provides 10-55 amps of current to the OGA cell stack during Process mode and 1.0 amps during Standby mode (2% oxygen production rate). The PSM is designed for 60,000 process/standby cycles, and a 10-year life.

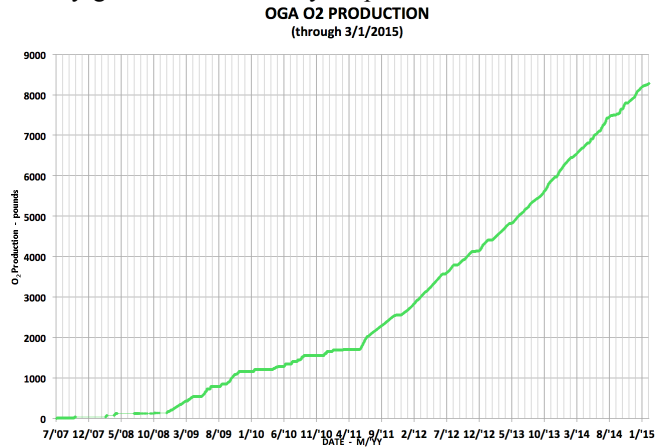


Figure 2 - Total Oxygen Produced by the OGA.

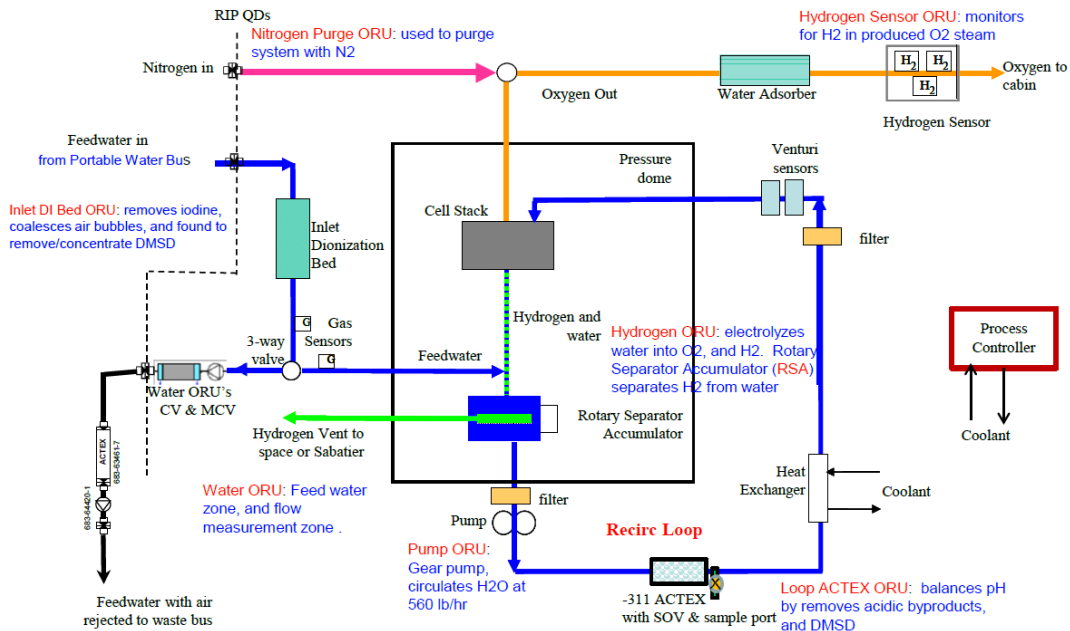


Figure 3 - OGA Simplified Schematic.

The OGA is designed to generate oxygen at a nominal rate of 5.4 kg/day (12 lbm/day) when operated on day/night orbital cycles (53 minutes at 100% production, 37 minutes in standby which produces 0.44 lbm/day of oxygen), and also at a selectable rate between 2.3 and 9.2 kg/day (5.1 and 20.4 lbm/day) or 22 to 100% oxygen production rate when operated continuously. At the nominal rate, the OGA can support oxygen needs for 4 crew, biological specimens, and atmosphere leakage, while at the maximum rate it can support 7 crew, biological specimens, and atmosphere leakage. The product oxygen meets quality specifications for temperature, free water, dew point, and hydrogen content. The OGA is packaged into eight ORUs, residing in the OGS rack. Most of the OGA ORUs are run to failure except for the calibration life limited Hydrogen Sensor ORU and the mixed-resin containing ORUs (Inlet DI Bed and ACTEX) which are trended for water throughput and return water quality to determine the Preventative Maintenance (PM) replacement intervals.

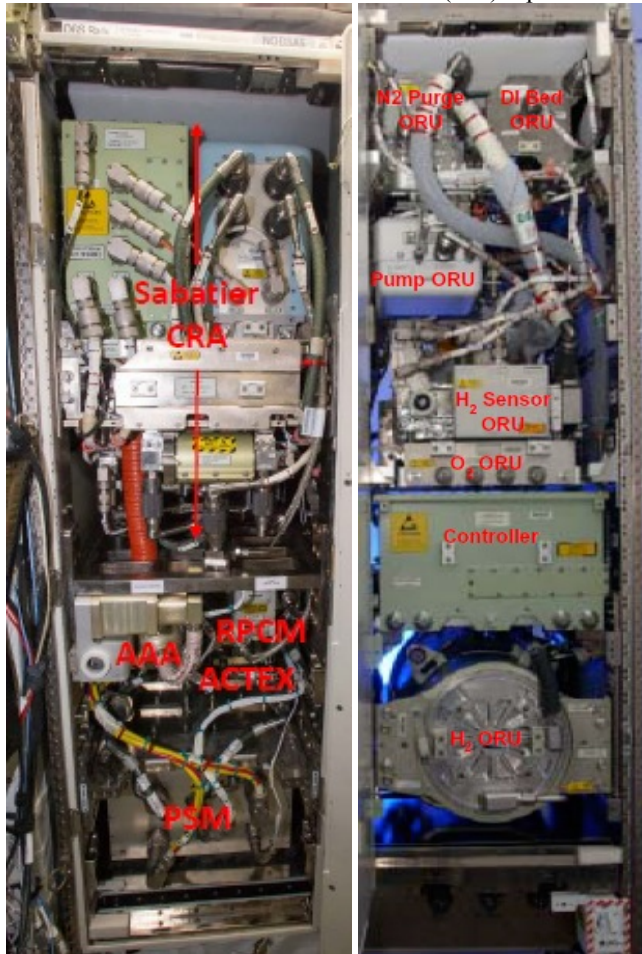


Figure 4 – OGS Rack.

### III. Lessons Learned from ISS OGA

The OGS has been on-orbit for over 8 years. Significant lessons have been learned through OGS operational experiences, both nominal and off-nominal workarounds. Figures 5 and 6 detail significant OGA events.

The major lesson learned is to have a mixed resin deionization bed always installed within the OGA water recirculation loop to maintain near neutral pH and minimize corrosion product contamination and maximize cell stack life. The OGA was initially launched without a deionization bed. After the cell stack failure (described in later in this section), a deionization bed was retrofitted in the recirculation loop in 2011.



to sensor drift, calibration life limitations, and could be a run to failure ORU which would eliminate the need for PM replacements.

During OGA failure troubleshooting or attempts to implement workarounds to regain system functionality, the team is limited by the OGA Independent Shutdown Monitor (ISM) hard-wired function that can not be disabled or overridden to new limits. The OGA ISM function provides automatic, hard-wired limit protection from system hazards by the removal of power to all system effectors. The ISM function is implemented with hardware which is fully independent of the OGA Process Controller software. There could be more operational flexibility if the ISM function could be disabled temporarily.

Another significant lesson learned is to minimize the use of filters within any future system and locate them such that they are easily inspected and replaceable or cleaned. Typical OGA ORUs with imbedded filters require the replacement of the entire ORU if a filter becomes occluded.

The OGA Hydrogen Dome Assembly ORU cannot be disassembled on-orbit by the crew to perform maintenance on the internal components (cell stack, RSA, valves, and sensors). The large stainless steel dome covering the ORU as fracture control protection is not removable by the crew. Future system redesigns should attempt to employ alternative hazard controls and methods that could eliminate the need for a dome.

It would be desirable to design thermal expansion capability into all water filled ORUs and to use only fluid flexhose types that can adequately accommodate water expansion due temperature increases. This capability is required when ORUs and flex hoses are disconnected for maintenance. On ISS, additional crew time must be used to find and install compatible thermal expansion devices to preclude exceeding Maximum Design Pressure (MDP) limits of the hardware.

The ability to disable keying of the fluid Quick Disconnects (QDs) will allow for more flexibility when the crew needs to respond to on-orbit OGS contingency cases.

#### **A. Cell Stack Failure in 2010**

On July 5, 2010, after approximately 233 days of cumulative operation, the first installed OGA Hydrogen Dome ORU's cell stack had a high voltage failure. The ORU rated life is five years. The ORU was replaced with an on-orbit spare and the failed ORU was returned in March 2011 to the ground for failure investigation. Prior to the ORU failure, the upstream recirculation loop filters were clogging. In addition, analysis determined that the filters were partially loaded with metallic corrosion products and the recirculation loop water pH was 4.1. The desired recirculation loop pH level is between 6 to 7. At the time of the high voltage cell stack failure it was unclear what, if any, relationship existed between the recirculation loop high delta pressure, low pH of the returned water samples and the cell stack's high voltage failure. Initially, the team believed blockage of cell stack water flow passages caused water starvation resulting in an increase in cell resistance and voltage.

Hardware tear-down after the failure showed no evidence of restrictions within the cell stack water flow passages. Published literature for fuel cell technology identified that there is a known chemical degradation of the cell membrane polymer chain end groups during normal operation. In the case of cathode feed electrolysis, this degradation resulted in the formation and release of hydrofluoric and sulfuric acid into the recirculation loop water on the cathode side of the cell. This lowered the recirculation loop water pH to the point of corroding the normally corrosion resistant metals in the wetted loop. These corrosion products became the source of cations that contaminated the cell membranes. This reduced the water transport and proton conductivity of the cell membranes resulting in a rapid increase in cell resistance driving the voltage up to the high shutdown limit.

The original design of OGA included a recirculation loop deionization bed, but it was eliminated due to safety concerns of hydrogen gas build-up within it. The OGA was launched in 2006 without a deionization bed in the recirculation loop. The crew installed a mixed resin deionization bed (ACTEX) in the recirculation loop on 5/26/2011 as recurrence control. Subsequently, the recirculation loop pH returned to near neutral pH values. This bed removes the electrolysis generated acid, balances the pH & removes cationic contaminants responsible for accelerated membrane degradation. The OGA team instituted periodic polarization scans and recirculation loop water samples. The team recommended using long term Standby instead of Shutdown (to maintains loop water recirculation through the ACTEX). If shutdown of the OGA is necessary then use of a newly developed cell discharge procedure is required to ensure most reactants are recombined locally at the cell membranes to minimize zones of low pH.

## B. Hydrogen Sensor Drift

The OGA is required to be two fault tolerant to preventing a cell stack hydrogen leak into the oxygen delivery line from creating a catastrophic hazard (e.g. hazardous hydrogen release to ISS cabin). To meet this safety requirement, the three hydrogen sensors must provide two independent means for detecting hydrogen and shutting down the OGA system after a cell stack hydrogen leakage failure. Upon an OGA shutdown, redundant oxygen isolation valves close to prevent a hazardous hydrogen release to the ISS cabin. The hydrogen sensors are required to be one fault tolerant to detecting a fault and shutting down the OGA system.

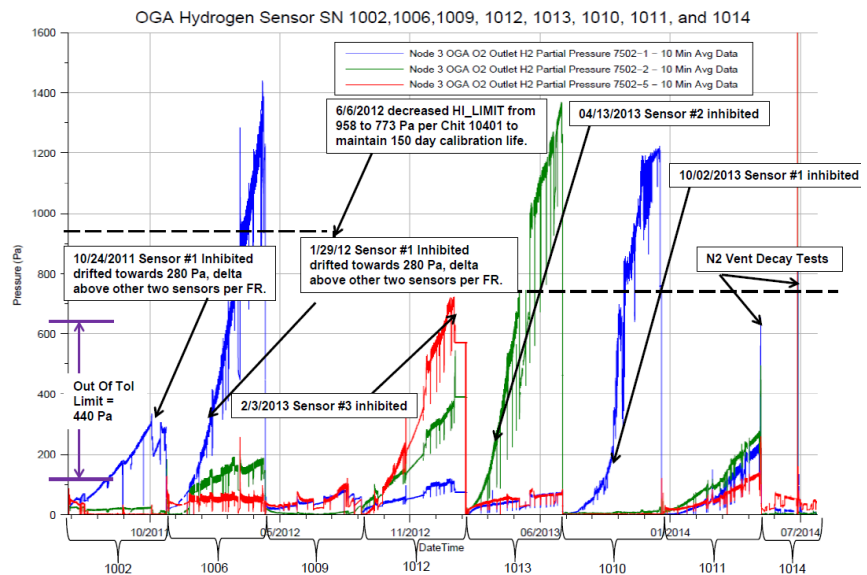


Figure 7 - Drifting Sensors Requiring Flight Rule Inhibits.

The Hydrogen Sensor ORU consists of three separate sensors dies. The current sensor calibration life is 150 days of “powered-on” time. Exposure of the dies to hydrogen gas changes the electrical output of the circuit in proportion to the partial pressure of hydrogen in the gas phase.

Five of the last ten installed Hydrogen Sensor ORUs have exhibited an unexplained, upwards drift (conservative direction towards high shutdown limit) in at least one of three sensor channels, requiring a ground commanded inhibit of that sensor to prevent system shutdown (see Figure 7). Sensors that exhibit this drift are diverging and rising upwards at different rates. Flight rules were established to inhibit a high drifting sensor when it exceeds the other two sensors within the ORU by 280 Pascals, and the remaining two are below 250 Pascals and also above -30 Pascals. The Flight rule ensures only one sensor is failed and the remaining two sensors are credible.

Sensor output increases (conservative direction towards high shutdown limit) as inert nitrogen gas displaces oxygen at the sensor’s active sites. During a normal shutdown or a nitrogen purge, the oxygen (anode) side of the cell stack is filled with nitrogen. Upon restart, the nitrogen is pushed out to the hydrogen sensors and a temporary biasing of the sensors occurs. The hydrogen sensors recover to their normal values after oxygen is being produced and the nitrogen is purged from the line out to the ISS cabin.

There are both known and unknown cross-contaminant chemical species that can influence the sensor’s electrical output. Sensor output is depressed by increasing amounts of water vapor and was quantified in sensor qualification life testing on nine sensor dies. Humidity is compensated for in the sensor’s ground calibration.

If a powered sensor die were to be exposed to liquid water, electrolysis reactions can occur on the die surfaces, causing destructive loss of the sensor’s functionality. To protect against this occurrence, die surface temperatures are maintained above the gas-phase dew point via local heaters whenever the OGA is powered. In the event that the system is unpowered, residual water vapor within the hydrogen sensor manifold can condense as internal ORU temperatures drop to cabin ambient. If the hydrogen sensor were to be re-powered with condensed water on the dies, damaging electrolysis reactions may occur and result in a shift in sensor output voltage. In order to preclude such an occurrence during either planned or unplanned OGA shutdowns, the crew is required to perform a dry oxygen purge of Hydrogen Sensor ORU. The crew uses ISS oxygen distribution lines connected to a Portable Breathing Apparatus hose and the Hydrogen Sensor ORU Purge Adaptor, to purge residual water vapor from the hydrogen sensor manifold. After the purge, the hydrogen sensor will be left in a dry condition from which it can safely be re-powered.

The OGA team believes the increasing response trend is due to a sensor drift issue (unknown cause) and is not due to incipient cell stack hydrogen leakage (from the cathode side across the cell membrane(s) to the oxygen anode side) for the following reasons: a) Periodic cell stack polarization scans indicate nominal voltage values for each 5 amp step increase in current, indicating a healthy cell stack with no cross-cell leakage. Any H<sub>2</sub> leakage to the anode side would recombine with oxygen in the presence of catalyst and cause cell voltage increases. b) When the OGA

has remained in long term Standby with mostly water in the two-phase cathode side recirculation loop, no RSA water quantity decreases have been detected. c) Common occurrence since drift has been seen on at least half of the ORUs installed on-orbit with typically one sensor drifting upwards more rapidly than the other two.

### C. Need for Day/Night Cycling

Given that the OGA is one of the major ISS power draws, there were initially constraints to its operations while ISS was power limited, prior to assembly complete. The OGA is designed to operate on day/night orbital cycles (53 minutes at 100% production, 37 minutes while in Standby) to minimize power consumption and battery draw during night portions of the ISS orbit. The OGA total maximum steady-state power consumption while in process mode is 3955 W. In Standby, the total maximum steady-state power consumption is 497 W. The ISS electrical system uses eight Solar Array Wings to directly convert sunlight to 120 volts DC electricity for equipment in the U.S. segment. The ISS power storage system consists of battery assemblies. A fourth and final set of solar arrays and batteries arrived in March in 2009 and allowed for continuous OGS oxygen production without having to employ the power saving day / night cycling. Since then, there has been minimal day / night cycling operations.

## IV. Requirements for a Long Duration Exploration Mission

A future OGA system for exploration should logically be based on the state of the art (SOA) ISS OGA. Since the ISS OGA has proven to be extremely safe and reliable over eight years of operation, it will provide an excellent foundation for the design of a future system. However, certain incremental improvements based on lessons learned should be considered. These will aim to reduce system mass, improve reliability and reduce the need for logistics resupply.

The general requirements for a future long duration exploration mission will likely be different from those that influenced the ISS OGA design. ISS OGA was originally designed to support a crew of 6 and a compliment of research laboratory animals. In addition, oxygen generation was constrained to only the daylight portion of the orbit. Therefore, the ISS OGA maximum production rate was required to be 20.4 lb/day. ISS benefits from frequent logistics resupply missions to provide spare parts to replace failed components.

Future exploration missions are expected to include 4 crewmembers and continuous power availability is assumed. Also, extravehicular activities (EVA's) are expected to be infrequent. Therefore, a much lower maximum oxygen production rate is envisioned for a future exploration mission. It is assumed that a future OGA system for exploration will only be required to generate 9.6 lb/day of oxygen, or less than half of the ISS OGA capability. Also, there are expected to be no (or very infrequent) logistics resupply missions.

There are certain areas of the ISS OGA design which might be considered overly conservative, leading to increased system mass/complexity and reduced maintainability. These areas of the design relate to managing hydrogen and oxygen. Over the many years of operating the ISS OGA, valuable experience and understanding has been gained relating to the safe management of hydrogen and oxygen. Through careful analysis and testing, some of the conservatism in the design can be reduced without adding appreciable risk. The benefit will be decreased system mass, complexity and logistics resupply from Earth.

## V. Proposed Incremental Improvements

Table 1 lists each of the proposed incremental improvements to the baseline design.

**Table 1. Proposed Improvements.**

Improvement	Reason	Description
Cell stack membrane replacement	SOA membrane is obsolete	Replace obsolete Nafion membrane with chemically stabilized Nafion membrane
Delete the nitrogen purge equipment	Reduce system mass and complexity	Delete nitrogen purging of the cell stack anode during shutdowns and startups
Replace hydrogen sensors	Reduce crew maintenance time	Replace hydrogen sensors with a more reliable technology that requires less crew intervention
Delete the wastewater interface	Reduce system mass and complexity	Allow oxygen gas that may be in the feedwater into the RSA rather than being rejected to the wastewater bus
Replace the hydrogen dome	Allow crew	Baseline dome design does not allow



	maintenance of cell stack and RSA	crew access to the internal dome components for maintenance
Downsize the PSM	Reduce system mass/volume	SOA PSM is oversized for a future mission

The safety and operational implications of implementing the proposed upgrades will be carefully analyzed by the OGA Team in 2015. The upgrades will be demonstrated on the developmental OGA (dev-OGA) located at NASA Marshall Space Flight Center. The dev-OGA is functionally equivalent to the ISS OGA. It contains a flight like cell stack, RSA, pump and PSM. Other components such as valves and sensors are commercial items. A picture of the dev-OGA is shown in Figure 8. Two of the proposed upgrades (nitrogen purge deletion and replacing the hydrogen sensors) have already been incorporated into the dev-OGA and over 100 hours of safe operation have been demonstrated to date. The rest of the upgrades will be incorporated into the dev-OGA in 2015. Then the next logical step over the coming years will be to incorporate some of these upgrades into the ISS OGA and demonstrate safe operation in microgravity.



Figure 8 - Dev-OGA.

#### D. Replacing the Cell Stack Membrane

The ISS OGA cell stack is a cathode feed design, with 28 cells to electrolyze water to generate oxygen and hydrogen. Each cell contains a cathode compartment and an anode compartment, separated by a Nafion membrane (manufactured by DuPont). Thin layers of catalyst are applied on each side of the membrane to form the anode and cathode electrodes of the cell. In this design, feed water is circulated on the cathode side of the cells, where hydrogen is generated. Excess water carries away the produced hydrogen and process heat. The membrane's high water permeability allows sufficient water transport to the anode, where the electrolysis actually takes place. Oxygen is generated at the anode, where it is virtually free of liquid water.

The original Nafion membrane material used in the ISS OGA cell stack is obsolete. DuPont now offers "chemically stabilized" Nafion, which has a much lower fluoride release rate. This chemically stabilized Nafion has not been incorporated into the ISS OGA cell stack or any spares. Another consideration is that the ISS OGA cell stack vendor, United Technologies Aerospace Systems (UTAS), no longer manufactures cell stacks.

The buildup of hydrofluoric acid within the recirculation loop was the cause of the ISS OGA cell stack failure in 2010. Incorporating chemically stabilized Nafion, with its lower fluoride release rate, should improve system reliability.

Thus, there is a need to qualify a new cell stack design from a new vendor now for future long duration missions. This process involves three steps:

- Build and endurance test newly designed single cells
- Build and acceptance test a newly designed 28-cell stack



Figure 9 - Single Cell with CS-Nafion.

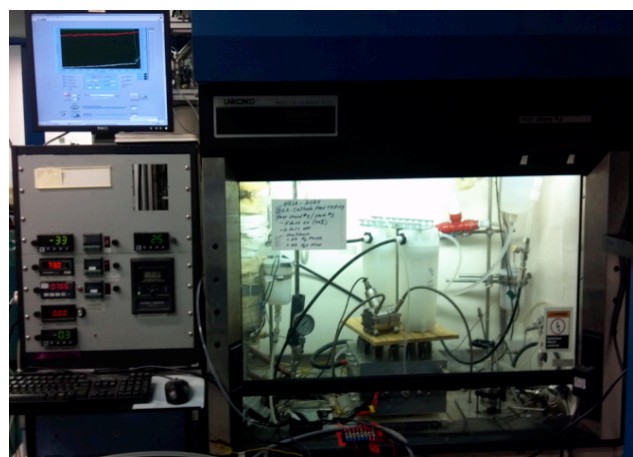


Figure 10 - Single Cell Test Stand.

- Integrate the new cell stack into the dev-OGA and verify system performance

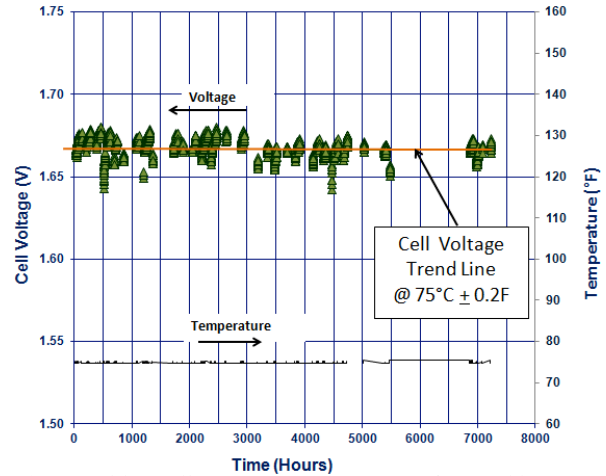
In 2014, NASA contracted with Giner, Inc. to build three single cells. These single cells were of the same design as the ISS OGA cells (same physical dimensions, active area, and current density), except that the newer chemically stabilized Nafion was used for the membranes. A single cell is shown in Figure 9.

These single cells were operated in the same manner as is done on ISS: cathode water feed configuration and 0.73 lb/day of ambient pressure oxygen production.

The testing was configured as follows:

- The first cell was operated continuously for four months
- The second cell was operated cyclically for four months (five days on, two days off, with shutdown nitrogen purging and shutdown cell discharging; as done on ISS)
- The third cell was operated cyclically for ten months (five days on, two days off, without shutdown nitrogen purging or shutdown cell discharging)

Figure 10 shows the test stand for one of the single cells. Essentially no cell voltage degradation (i.e. increase in cell voltage over time) was noted for any of the cells over the four month and ten month period. Figure 11 shows the cell voltage of the third cell over a period of 10 months of operation.



**Figure 11 - Cell Voltage Trend Over 10 Months.**

After all endurance testing was completed, the three single cell passed health checks, as shown in Table 2.

**Table 2 - Post-Endurance Test Health Check.**

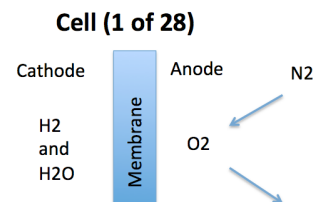
Post Test Health Check	Pass?	Comment
Polarization Scan	Yes	No indication of water transport limitation at maximum current density
Resistance Measurement	Yes	No appreciable increase in resistance after endurance test
Short Test	Yes	
Cross Cell Leak Test	Yes	
Overboard Leak Test	Yes	
Oxygen Purity	Yes	0.01% H2 detected
Catalyst Shedding	Yes	Nearly undetectable amount of catalyst detected in downstream water filter

Based on these excellent single cell test results, a newly designed cell stack should meet or exceed the 5 year life of the heritage cell stack.

A complete 28 cell stack with chemically stabilized Nafion membranes will be built in 2015. The intent will be to build a “drop-in replacement” stack, compatible with the ISS OGA balance of plant. The cell construction will be the same as the three single cells. The non-repeating hardware (such as the end plates) will not be required to be the same as the heritage ISS design. Once the cell stack is assembled and passes acceptance testing, it will be delivered to NASA (expected in November 2015). The new cell stack will be integrated into the dev-OGA at MSFC, and the long term performance of the new cell stack will be compared to the heritage OGA cell stack.

**E. Deleting the Nitrogen Purge Equipment**

The ISS OGA requires an external source of nitrogen, provided by the ISS vehicle. The ISS OGA has approximately 50 lb of equipment to handle the storage



**Figure 12 - Nitrogen Purge of Anode.**

and distribution of nitrogen. Nitrogen is used for two purposes. The first is to purge the cell stack anode upon system shutdown and startup (see Figure 12).

During prolonged shutdowns, hydrogen in the cathode compartment will migrate through the membrane to the anode compartment, which contains oxygen. A nitrogen purge will replace the oxygen with nitrogen, preventing a mixture of hydrogen and oxygen in the anode. The second purpose is to fill the hydrogen dome prior to removal from the system with nitrogen to create an inert condition for transportation. If the hydrogen dome is deleted, as proposed in this paper, the need for inerting the dome will be obviated.

The benefit of deleting the nitrogen purging equipment is a reduction in system complexity and weight. In addition, the vehicle design will be simplified since it will not be required to supply nitrogen to OGA.

Deleting nitrogen purging during the shutdown process will mean that oxygen in the anode will not be removed. It will also mean that the cathode pressure will be higher than the anode pressure, and that hydrogen will permeate through the membrane to the anode, where oxygen is. The hydrogen and oxygen should safely combine to form water, in the presence of catalyst.

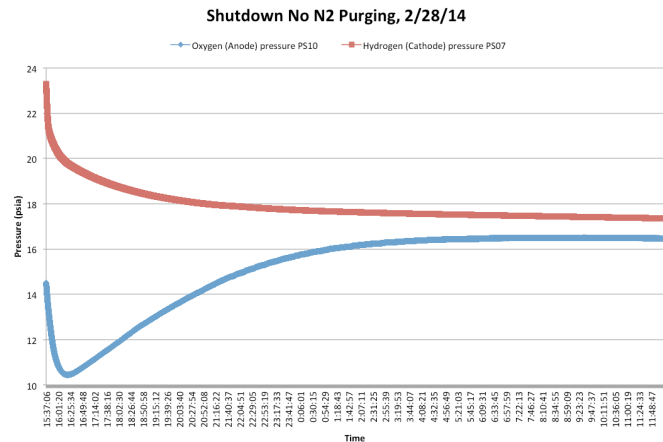
Deleting nitrogen purging during the startup process will mean that any hydrogen that has permeated through the membrane during periods of dormancy could be vented out the oxygen outlet after startup. However, if hydrogen and oxygen combine to form water, then there should be very little hydrogen exiting out the oxygen outlet.

During the single cell testing (described in the previous section) at Giner, one of the cells was operated safely without any nitrogen purging for ten months. No safety issues or change in functional performance occurred. At UTAS, flight ISS OGA cell stacks are operated safely without nitrogen purging during ground testing.

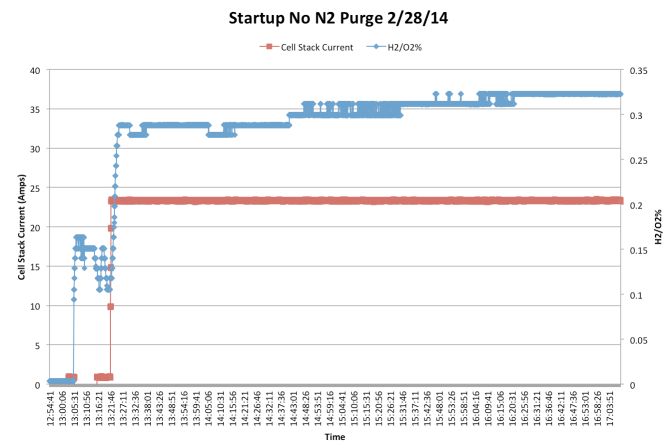
The dev-OGA was modified in Feb 2014 to operate without nitrogen purging of the anode during shutdown and startup. To date, the dev-OGA has operated for 135 hours safely without any nitrogen purging.

Figure 13 shows the cathode/hydrogen (red line) and anode/oxygen (blue line) pressure after a shutdown of the dev-OGA without performing a nitrogen purge. After about 12 hours it can be seen that both sides of the cells equalize fairly closely in pressure (within 1 psi). The decrease in hydrogen pressure (red line) indicates that hydrogen is permeating across the membrane from the cathode to the anode. The initial decrease in oxygen pressure (blue line) to sub-ambient pressure (10.5 psia) indicates that hydrogen permeating across to the anode and safely combining with oxygen to form water and not creating a hazardous condition.

Figure 14 shows the percent hydrogen present in the product oxygen (blue line) and the cell stack current (red line) during a startup without nitrogen purging. Once oxygen production begins (cell stack current increases to 23 Amps), the percent hydrogen in the oxygen outlet rises to 0.3 – 0.35% (blue line), still well below the lower flammability limit (LFL) of 4.0%. Table 3 shows the percent hydrogen in oxygen measured during other system startups without nitrogen purging. In all cases, the percent hydrogen in oxygen at startup is well below the LFL.



**Figure 13 - Cathode and Anode Pressure After Shutdown.**



**Figure 14 - Percent Hydrogen in Oxygen and Cell Stack Current on Startup.**

**Table 3 - Percent Hydrogen in Oxygen on Startup.**

Date	Percent Hydrogen in Oxygen During Startup	Comment
2/25/14	0.2%	Startup after being shut down for 1 day
3/3/14	0.45%	Startup after being shut down for 3 days
6/26/14	0.3%	Startup after being shut down for 112 days
7/1/14	0.3%	Startup after being shut down for 5 day

Safe operation of the dev-OGA without shutdown or startup nitrogen purging has been demonstrated in 2014. The dev-OGA will continue to be operated with nitrogen purging disabled in the future.

When nitrogen purging is deleted, liquid water is present in the oxygen outlet during startup. An average of 125 mL of water is pushed out of the cell stack during each startup. A method for handling this liquid water in microgravity will need to be implemented.

One special case will need further analysis if nitrogen purging is deleted. In the event of a cross cell leak failure, where hydrogen and water could enter into the anode, no nitrogen purging will occur at shutdown.

#### F. Replacing the Hydrogen Sensors with a Recombiner

The ISS OGA contains three independent hydrogen sensors to monitor for hydrogen in the product oxygen prior to being released into the ISS cabin atmosphere. The process controller shuts down the OGA if any of the sensors detect more than one percent hydrogen in oxygen. The presence of hydrogen in the product oxygen indicates a cross cell leak within the cell stack. The hydrogen sensors are sensitive to moisture. Condensation on the hydrogen sensor dies while being powered will cause permanent damage. To prevent condensation, heaters maintain the temperature above the dew point of the oxygen coming from the cell stack. After every system shutdown, the crew must connect the hydrogen sensors to a dry oxygen source to remove condensation. The hydrogen sensors must be returned to earth every 150 days for recalibration.

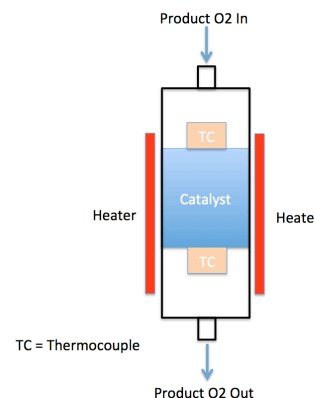
A recombiner is proposed as a replacement to the existing hydrogen sensors in the oxygen outlet line. A recombiner (aka catalytic reactor) is a simple device: a metal housing containing catalyst with integral thermocouples, as shown in Figure 15. An external heater is wrapped around the housing to heat the catalyst, as shown in Figure 16. This will always keep the catalyst temperature above the dew point of the incoming oxygen and prevent condensation on the catalyst. Exposed, unsheathed thermocouples are used for fastest response.

If hydrogen is present in the product oxygen stream, it will combine with the oxygen in the presence of the catalyst and release heat. The integral thermocouples will detect a temperature increase and the system can be safely shutdown. For adequate safety margin, 1% and greater hydrogen in oxygen will need to be detectable.

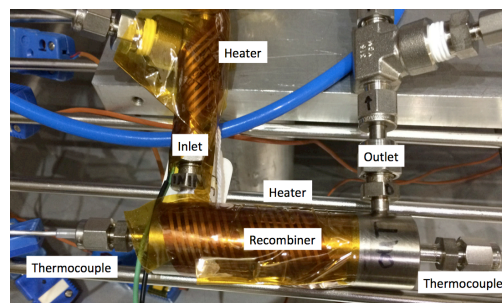
There are several benefits to replacing the current hydrogen sensors with a recombiner. The recombiner should be able to remain installed for years without the need for periodic removal and ground calibration. It will not require dry oxygen purging by the crew after every system shutdown.

Deactivation or poisoning of the catalyst is a long term concern which will require further investigation in 2015.

A recombiner from Resource Systems, Inc. was tested under a range of conditions that would be seen in system operation: flow rates from 1.2 lpm to 4.5 lpm and dew points from 60 F to 85 F. The hydrogen in oxygen concentration was varied from 0 – 3.5% to simulate a cross cell leak in the cell stack.

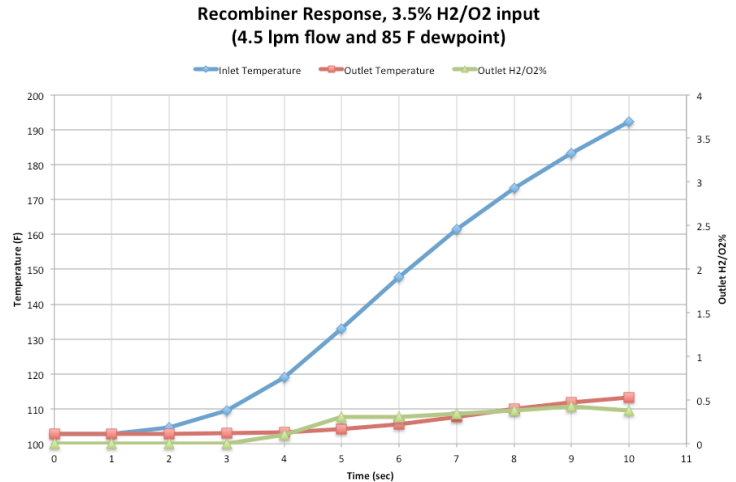


**Figure 15 - Recombiner Cross Section.**



**Figure 16 - Recombiner with Heater.**

The response of the recombiner to 3.5% hydrogen in oxygen is shown in Figure 17 for the case of 4.5 lpm flow and 85 F dew point. In less than 10 seconds, a rapid increase in the inlet temperature (blue line) is seen. OGA system software can be configured to immediately shutdown the system once a rapid temperature increase is detected. Another positive point is that most of the hydrogen is removed by the recombiner. The measured amount of hydrogen in oxygen at the outlet (green line) is less than 0.5% (compared to 3.5% at the inlet). Table 4 shows the time for the recombiner temperature to reach 130 F with 3.5% hydrogen in oxygen input, at various flow rates and dew points.



**Figure 17 - Recombiner Temperature Response to 3.5% H2/O2.**

**Table 4 - Recombiner Response Time to 3.5% H2/O2.**

	60 F dew point	72.5 F dew point	85 F dew point
1.2 lpm flow	6 s	6 s	8 s
4.5 lpm flow	4 s	4 s	5 s

If a shutdown limit of 130 F for the recombiner temperature is in place, then the system will be shut down in 8 seconds or less in the event of a cross cell leak. In all cases, the amount of hydrogen at the outlet is less than 0.5%. With a smaller cross cell leak, such as one resulting in 1% hydrogen in oxygen, the recombiner response time will be longer (on the order of 2 to 3 minutes), but should be acceptable since very little hydrogen allowed out to the cabin.

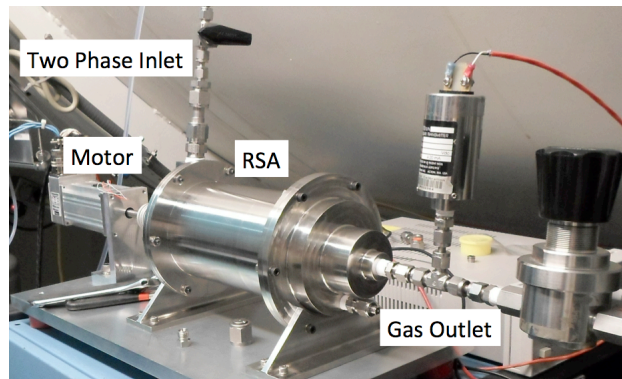
**G. Deleting the Wastewater Interface**

Feed water is batch supplied to the ISS OGA to replace water consumed by electrolysis. Feed water flows through an inlet deionizing bed to remove iodine. Oxygen in the feedwater can coalesce in the inlet deionizing bed and oxygen bubbles will be released periodically out of the bed. Two gas sensors will detect this release and a three-way valve will divert the feed water to the wastewater bus and prevent oxygen gas bubbles from entering the RSA where it could mix with hydrogen gas. Once the feed water is clear of oxygen bubbles, the three-way valve is repositioned to allow water flow into the RSA. The system is protected from waste water back flow by physical and microbial check valves.

After eight years of operation, gas bubbles in the feed water have been detected occasionally. There are six known events (8/21/09, 11/14/09, 4/14/10, 12/19/13, 7/30/14, 8/12/14) where the feed water was diverted to the wastewater bus due to gas detected in the feed water. On 12/19/13, oxygen gas was detected in the feed water and allowed to go into the RSA (because the gas was detected downstream of the 3-way valve, it was not possible to send this oxygen bubble to the wastewater bus). After this event, the OGA continued to operate nominally.

If the wastewater interface were to be deleted from a future design, oxygen bubbles from the inlet deionizing bed would always be allowed to go into the RSA (where there is hydrogen and water) and not be diverted out of the system. There is a concern that there could be a deflagration within the RSA.

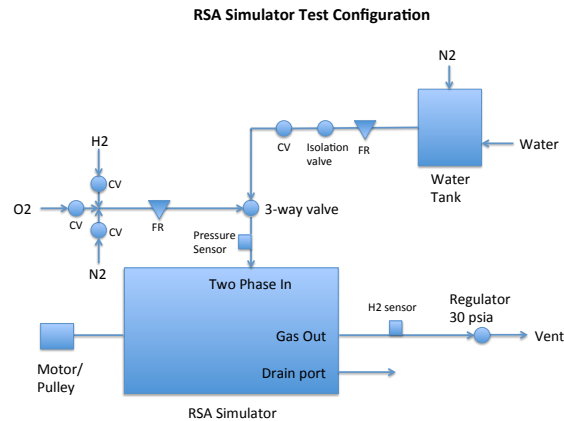
To understand the effect of allowing oxygen into the RSA, ground testing is proposed for 2015. A RSA test article was manufactured in 2014 and is shown in Figure



**13 Figure 18 - RSA Test Article.**

18.

The proposed test configuration is shown in Figure 19. The initial test condition of the RSA will be as it is on-orbit: filled with the same ratio of water and hydrogen. Next, oxygen will be introduced into the RSA. The oxygen in hydrogen mixture will be gradually increased from 0% to 100%, changing from the upper flammability limit to the lower flammability limit. A stoichiometric mixture of hydrogen and oxygen within the RSA will be tested. Cell stack catalyst will be introduced into the RSA, since there is a concern that the catalyst could shed from the cell stack and collect in the RSA where it could promote an ignition. The RSA will be monitored for signs of deflagration throughout the test period. In the event that no ignition occurs, a stoichiometric mixture of hydrogen and oxygen (along with water) in the RSA will be purposely ignited to determine the structural capability of the RSA.



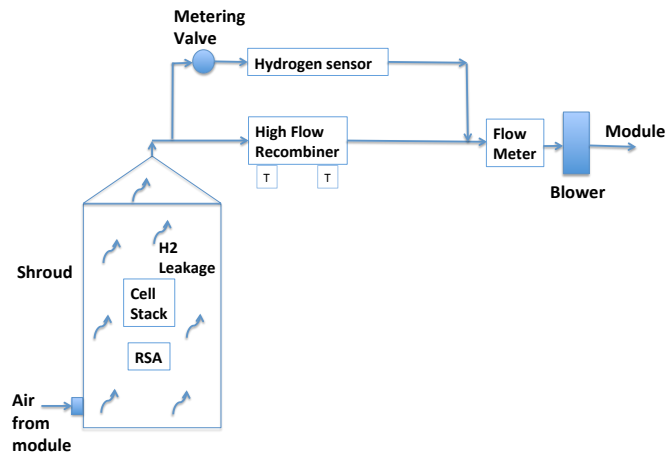
**Figure 19 - RSA Test Schematic.**

If it can be shown that a detonation in the RSA is not credible when oxygen bubbles are allowed in from the feed water, then the wastewater interface will be deleted from the design.

### H. Replacing the Hydrogen Dome with a Shroud

The ISS OGA hydrogen dome encloses all hydrogen containing components: cell stack, RSA, valves, sensors and connecting tubing. The dome is connected to space vacuum and is maintained at a vacuum. The purpose of the dome is to detect hydrogen leakage out of the cell stack or RSA (via a pressure rise in the dome), contain hydrogen leakage and contain any possible detonation event.

There are commercial and military cell stacks that operate safely for thousands of hours without a dome. During ground testing, the ISS OGA cell stacks are regularly operated safely without a dome. The dome was incorporated into the ISS OGA design out of an abundance of safety conservatism. The disadvantage of the dome is that the internal components (cell stack, RSA, valves, sensors, etc.) are inaccessible to the crew for maintenance. If one of the components fails (such as a valve), the entire dome assembly (275 lb) will need to be replaced. In over eight years of operation on ISS and on the ground, no external leakage out of the cell stack or RSA has occurred.



**Figure 20 - Shroud Configuration.**

A removable shroud concept is proposed as a replacement to the dome for the dev OGA in 2015. The concept is depicted in Figure 20. Air, at a flow rate of 240 lpm, is forced over the cell stack and RSA. This air is then routed through a hydrogen sensor and recombiner. Hydrogen leakage will be detected via a temperature increase of the recombiner catalyst and the hydrogen sensor reading and the system will be safely shut down. The air flow rate is high enough so that even at the maximum hydrogen leakage rate (out of the cell stack or RSA), the mixture is below the lower flammability limit of 4%. Therefore, the shroud configuration still allows for external leakage detection while allowing crew maintenance of the internal components. Analysis

and testing is proposed for 2015 to show that the cell stack and RSA will not credibly support an internal detonation that would lead to accelerated shrapnel that could be a crew hazard. Liquid water will also likely leak, along with the hydrogen. The effect of water possibly being ingested by the recombiner will need to be analyzed.

### I. Downsizing the Power Supply Module (PSM)

The ISS OGA PSM is a constant current power supply for the cell stack. It is able to provide over 3800 Watts of power for electrolysis. The PSM is a modular design, containing 4 power converter units along with filter boards, control board, relay, etc. The internal configuration is shown in Figure 21. The PSM has a weight of 100 lb.

Since the oxygen production rate for a future OGA system will likely be less than one half of that of the ISS OGA, the output current of a future PSM design can be reduced by at least one half. A redesigned PSM could have two of the four power converters removed for weight savings (of about 30 lb). The remaining boards could be reoriented parallel to the converters for volume savings. Currently, there is no funding available to redesign the PSM in 2015.

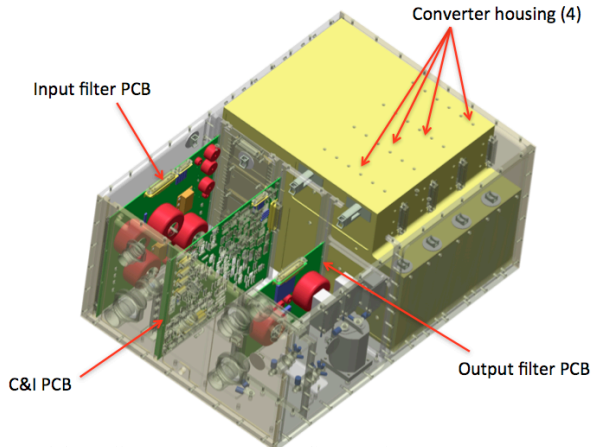


Figure 21 - PSM Internal Configuration.

## VI. Proposed Next Generation OGA Architecture

A proposed schematic for a next generation OGA is shown in Figure 22. The ISS OGA design is used as the basis, but with certain improvements incorporated. The system includes a 28-cell stack with chemically stabilized Nafion membrane material. The cathode feed configuration is retained, along with the RSA. No nitrogen purging or wastewater interface is included. A recombiner is shown in the oxygen outlet. A shroud with forced air flow over the cell stack and RSA is shown as a replacement to the vacuum dome. This air flow is routed through a recombiner for leak detection. By the end of 2015, the dev-OGA will be configured as shown in the proposed schematic. Subsequently, the

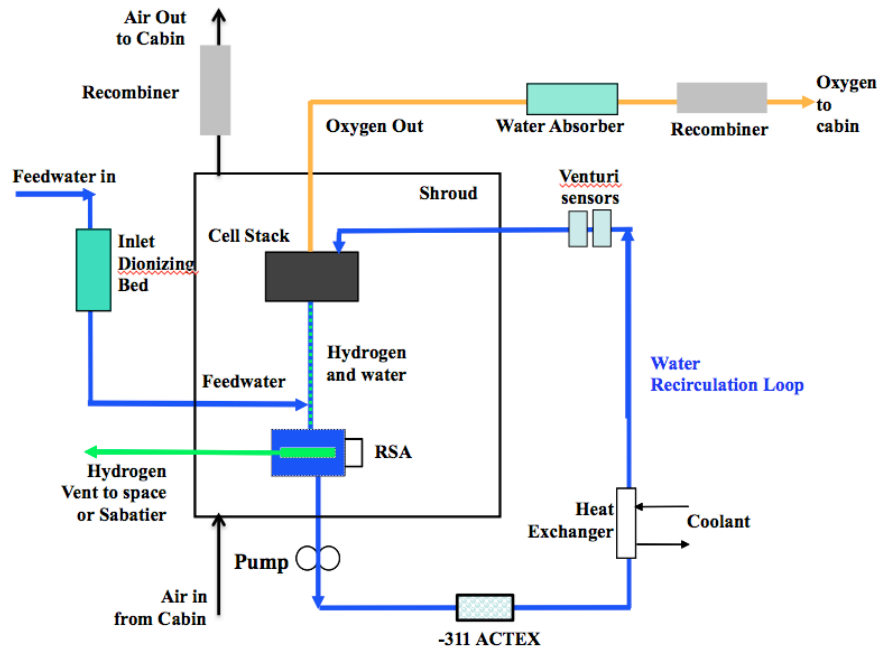


Figure 22 - Proposed Schematic for a Future OGA.

upgrades will be proposed for incorporation into the ISS OGA. Deleting the nitrogen purge and the wastewater interface could be easily implemented in the ISS OGA, with software changes and without launching new hardware. The other upgrades can be implemented, but would require the launching of new hardware.

## References

<sup>1</sup>B. Erickson, J. Howe, G. Kulp, and S. Van Keuren “International Space Station United States Orbital Segment Oxygen Generation System On-Orbit Operational Experience,” SAE 2008-01-1962, 38<sup>th</sup> International Conference on Environmental Systems, San Francisco, CA, July 2008.

<sup>2</sup>R. Bagdigian, K. Prokhorov, “On-Orbit Checkout and Activation of the ISS Oxygen Generation System,” SAE 2007 2007-01-3182, 37<sup>th</sup> International Conference on Environmental Systems, Chicago, IL, July 2007.

<sup>3</sup>R. Bagdigian, D. Cloud, and J. Bedard, “Status of the Regenerative ECLSS Water Recovery and Oxygen Generation Systems”, SAE 2006-01-2057, 36<sup>th</sup> International Conference on Environmental Systems, Norfolk, VA, July 2006.