

DSMC Simulations of Disturbance Torque to ISS during Airlock Depressurization

F. E. Lumpkin III and B. S. Stewart

Applied Aerospace and CFD Branch
 NASA Johnson Space Center
 Houston, TX 77058-3963 USA
 forrest.e.lumpkin@nasa.gov

The primary attitude control system on the International Space Station (ISS) is part of the United States On-orbit Segment (USOS) and uses Control Moment Gyroscopes (CMG). The secondary system is part of the Russian On-orbit Segment (RSOS) and uses a combination of gyroscopes and thrusters. Historically, events with significant disturbances such as the airlock depressurizations associated with extra-vehicular activity (EVA) have been performed using the RSOS attitude control system. This avoids excessive propulsive “de-saturations” of the CMGs. However, transfer of attitude control is labor intensive and requires significant propellant. Predictions employing NASA’s DSMC Analysis Code (DAC) of the disturbance torque to the ISS for depressurization of the Pirs airlock on the RSOS will be presented [1]. These predictions were performed to assess the feasibility of using USOS control during these events. The ISS Pirs airlock is vented using a device known as a “T-vent” as shown in the inset in figure 1. By orienting two equal streams of gas in opposite directions, this device is intended to have no propulsive effect. However, disturbance force and torque to the ISS do occur due to plume impingement. The disturbance torque resulting from the Pirs depressurization during EVAs is estimated by using a loosely coupled CFD/DSMC technique [2]. CFD is used to simulate the flow field in the nozzle and the near field plume. DSMC is used to simulate the remaining flow field using the CFD results to create an in flow boundary to the DSMC simulation. Due to the highly continuum nature of flow field near the T-vent, two loosely coupled DSMC domains are employed. An 88.2 cubic meter inner domain contains the Pirs airlock and the T-vent. Inner domain results are used to create an in flow boundary for an outer domain containing the remaining portions of the ISS. Several orientations of the ISS solar arrays and radiators have been investigated to find cases that result in minimal disturbance torque. Figure 1 shows surface pressure contours on the ISS and a plane of number density contours for a particular case.

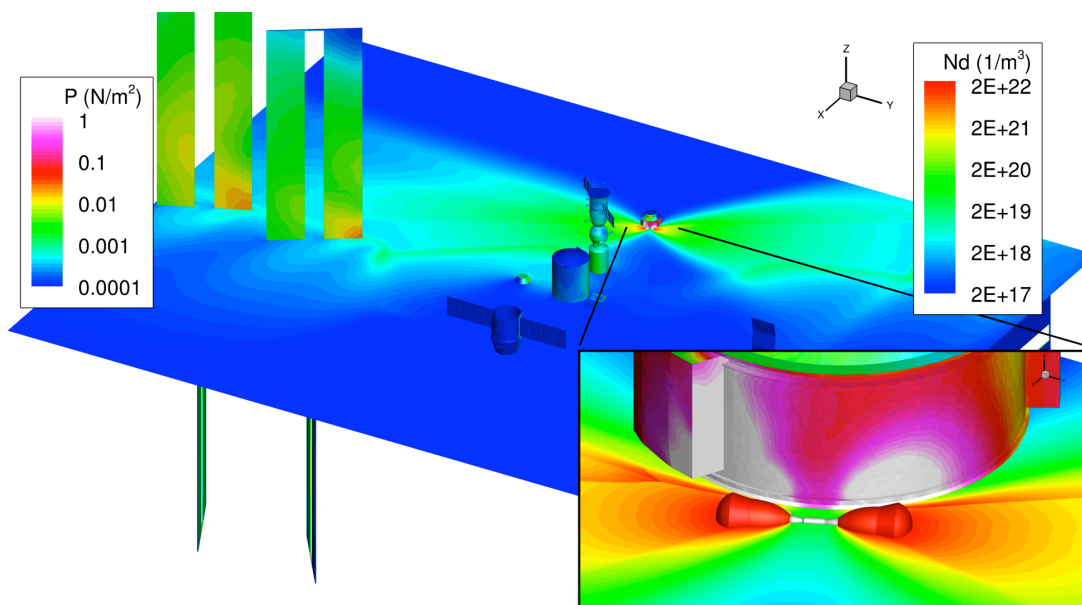

Figure 1. Surface pressure and flow field number density contours for depressurization of the ISS Pirs module.

- [1] G. J. LeBeau, “A parallel implementation of the direct simulation Monte Carlo method,” *Computer Methods in Applied Mechanics and Engineering*, **174** (3-4), 319-337 (1999).
 [2] F. E. Lumpkin III, P. C. Stewart, and G. J. LeBeau, “Enhanced Analyses of Plume Impingement During Shuttle-Mir Docking Using a Combined CFD and DSMC Methodology,” AIAA-96-1877, Reston, VA (1996).



DSMC Simulations of Disturbance Torques to ISS during Airlock Depressurization

Forrest E. Lumpkin III, Ph.D. & Benedicte D. Stewart, Ph.D.

Applied Aeroscience and CFD Branch
NASA Johnson Space Center

DSMC 2015
September 15, 2015



Background & DC1 T-vent Description



- The ISS Program would like to perform Russian EVAs using USOS/CMG attitude control in order to simplify operations and reduce propellant usage.
- To reduce propulsive effects, DC1 depressurization is performed by venting the gas through a so-called “T-vent”.
 - Due to plume impingement, T-vents reduce but do not eliminate propulsive effects.
 - Assessment of the plume impingement effects is needed to assess USOS attitude control performance (e.g. obtain an upper bound on the number of CMG de-saturations required during depressurization).
 - Plume impingement effects will depend on the ISS configuration – in particular the orientation for the USPVs (SARJ and BGA angles) and ETCS radiators (TRRJ angles).
- The DC1 T-vent consists of two opposed supersonic nozzles
 - Nozzles have a 6.25 area ratio
 - Approximately Mach 3.41 at the nozzle exit as assessed by quasi 1D isentropic flow with area changes.
 - Mass flow rate per nozzle = 0.107 kg/s, Thrust per nozzle = 73.71 newton
 - Values assuming atmospheric stagnation conditions – $P_0 = 101325$ Pa, $T_0 = 300$ K
 - Vent axes located in constant ISS z plane rotated 23 degrees about ISS z axis
 - Port leg biased towards ISS forward, starboard leg biased towards ISS aft.
- Combined CFD/DSMC used to assess impingement forces and moments



DC1 T-vent

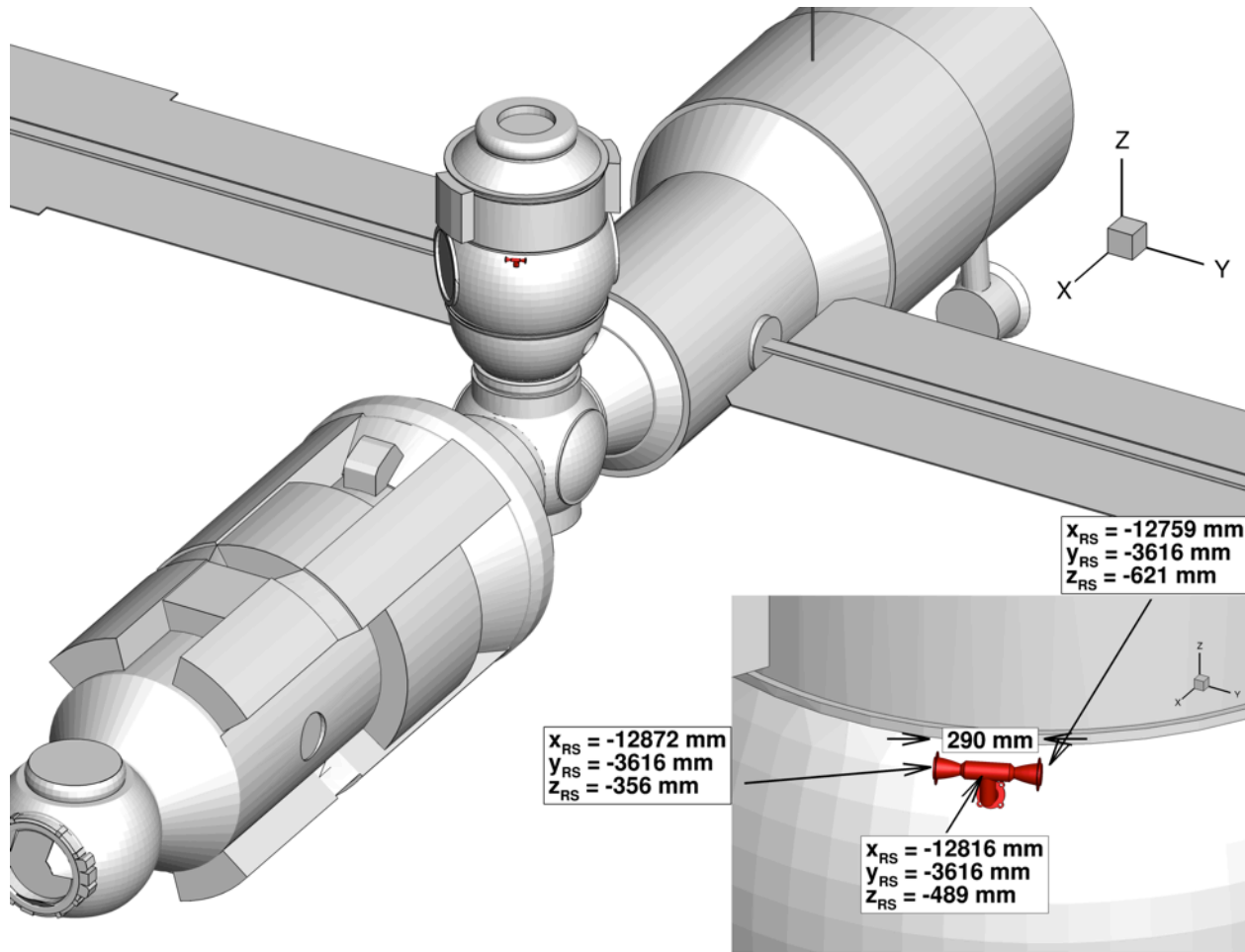



JSC DSMC Analysis Code (DAC97)



- Developed as a general purpose DSMC code, but with the plume impingement problem as a key capability.
 - Generalized surface with non-uniform inflow conditions ($\rho, \bar{\mathbf{u}}, T_{total}$)
 - Allows a plume boundary with conditions interpolated from a CFD (or another DSMC) simulation to be employed.
 - Assumes the in flow distributions are Maxwellian.
 - Advanced features to handle flows with large density gradients
 - Two level Cartesian mesh allows for refinement in areas with higher densities.
 - Scaling of real to simulated molecule ratio (FNUM) allows for nearly uniform number of simulated molecules per cell (goal ~ 10 for optimal performance and accuracy)
 - Time step scaling.
 - Nearest neighbor collision partner selection allows a slight relaxation of the mean free path cell size requirement
- Other notes on DAC97
 - Domain decomposition parallel implementation (MPI) with dynamic load balancing
 - Finite rate thermo-chemistry
 - Distribution 14 just released to users with significant enhancements
 - Ported from Fortran 77 to Fortran 90 (eliminated need for Cray style pointers)
 - Scalar and parallel source files combined (improves source code maintainability)
 - Now capable of simulations in excess of $2^{31}-1$ (2,147,483,647) simulated molecules



Simulation Strategy



- After some trial and error, the high fidelity simulation was divided into three regions
 - A nozzle and very near plume region simulated using traditional Navier-Stokes based CFD
 - Single nozzle, axisymmetric flow using NASA Ames DPLR code. Grid size: 135,168 cells
 - A near DC1 region simulated using Direct Simulation Monte Carlo (DSMC)
 - Region contained two “in-flow” boundary conditions based upon the results from the CFD sim.
 - “In-flow” boundaries were positioned upstream of any interactions with the DC1
 - 4.2 by 5.0 by 4.2 meters domain contained the complete DC1 but not the rest of ISS
 - 434 million cells, 15.95 billion molecules (after two solution adaptations)
 - A “rest of ISS” region simulated using Direct Simulation Monte Carlo (DSMC)
 - Region contained “in-flow” boundary conditions based upon the results near DC1 DSMC simulation – typical domain size 60 by 102 by 74 meters
 - “In flow” boundary was attached to DC1 with an appropriate hole cut in the DC1 surface
 - The rest of the ISS was included with case appropriate angles for SARJ, BGA, & TRRJ angles
 - Typically 116 million cells, 1.67 billion molecules
 - Advantage: only the “rest of ISS” needs to be re-run for each SARJ, BGA, TRRJ case.
- Simulation performed for atmospheric conditions in the DC1 at event initiation
 - $P_0 = 101325$ Pa, $T_0 = 300$ K
 - Resulting forces and moments time histories scaled by DC1 pressure for GN&C analysis



Simulation Strategy: Illustration

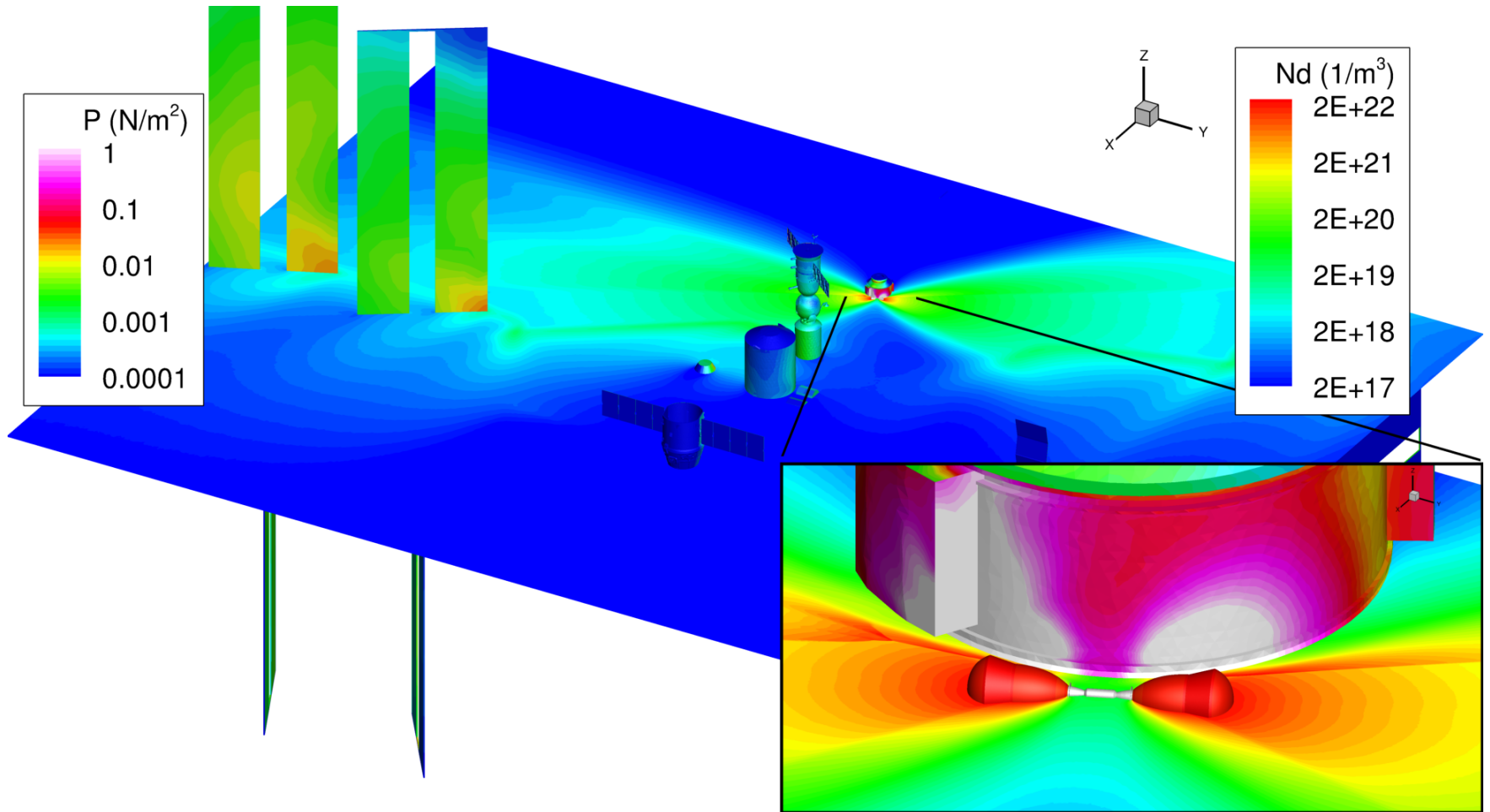



CFD Simulation Detailed Description



- NASA Ames DPLR CFD code employed
- Gas modeled as single species, perfect gas air.
- Axi-symmetric simulation
- Assumed atmospheric stagnation conditions
 - $P_0 = 101325 \text{ Pa}$, $T_0 = 300 \text{ K}$
 - Conservative as assumes no losses in the plumbing between the DC1 chamber and nozzle entrance.
 - Four point matched finite volume grids
 - Grid 1: 65 by 257, subsonic portion of nozzle
 - Grid 2: 193 by 257, supersonic portion of nozzle
 - Grid 3: 257 by 257, main plume
 - Grid 4: 17 by 257, plume back flow
 - Mass flow rate = 0.10667 kg/s, Thrust = 73.293 newton
- Assume that estimates for moments at this condition can be scaled linearly by time history of the DC1 pressure to estimate the time dependent moments during the depressurization event(s).



CFD grid

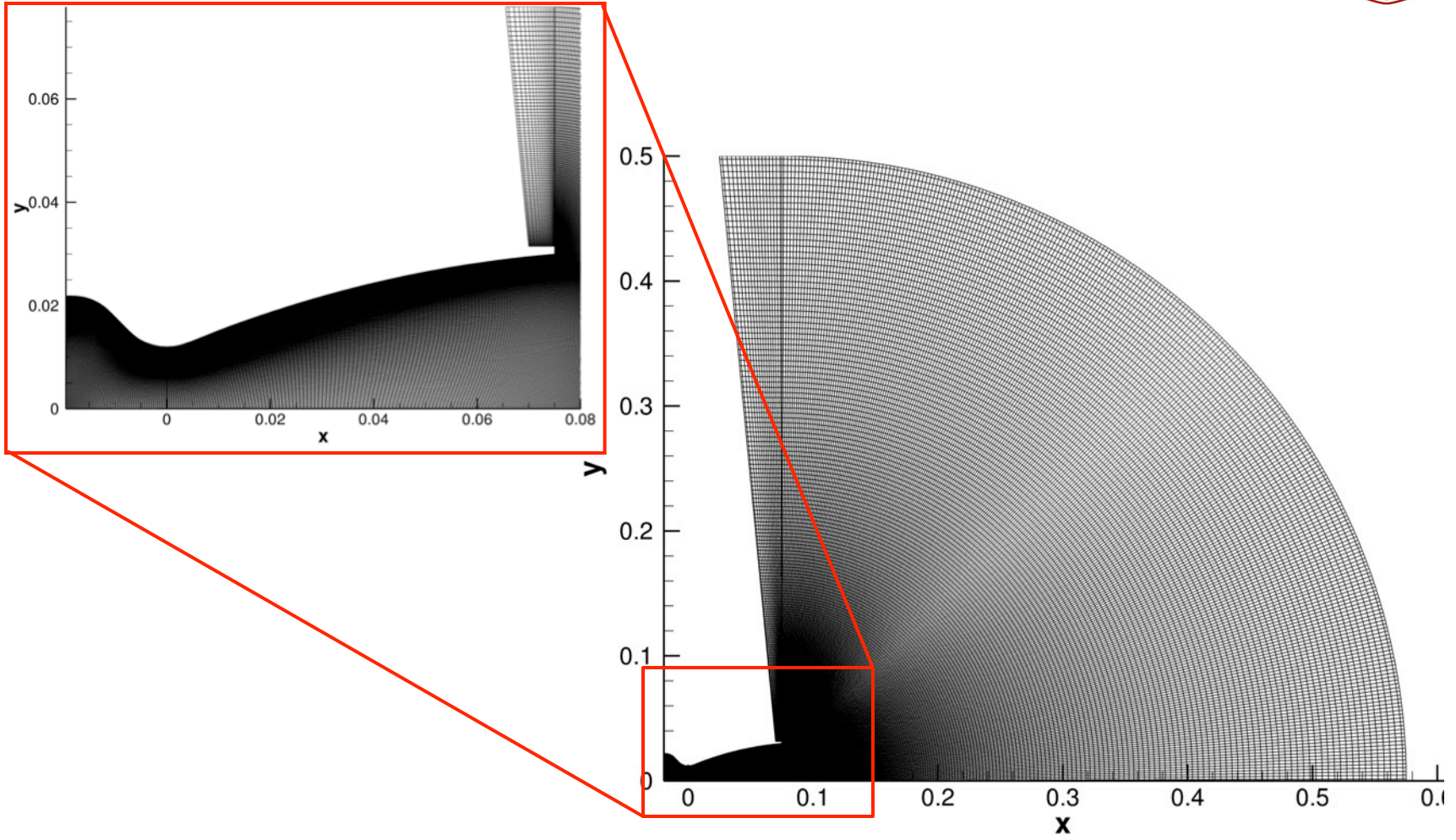



CFD Results: Pressure Contours (Pascal)

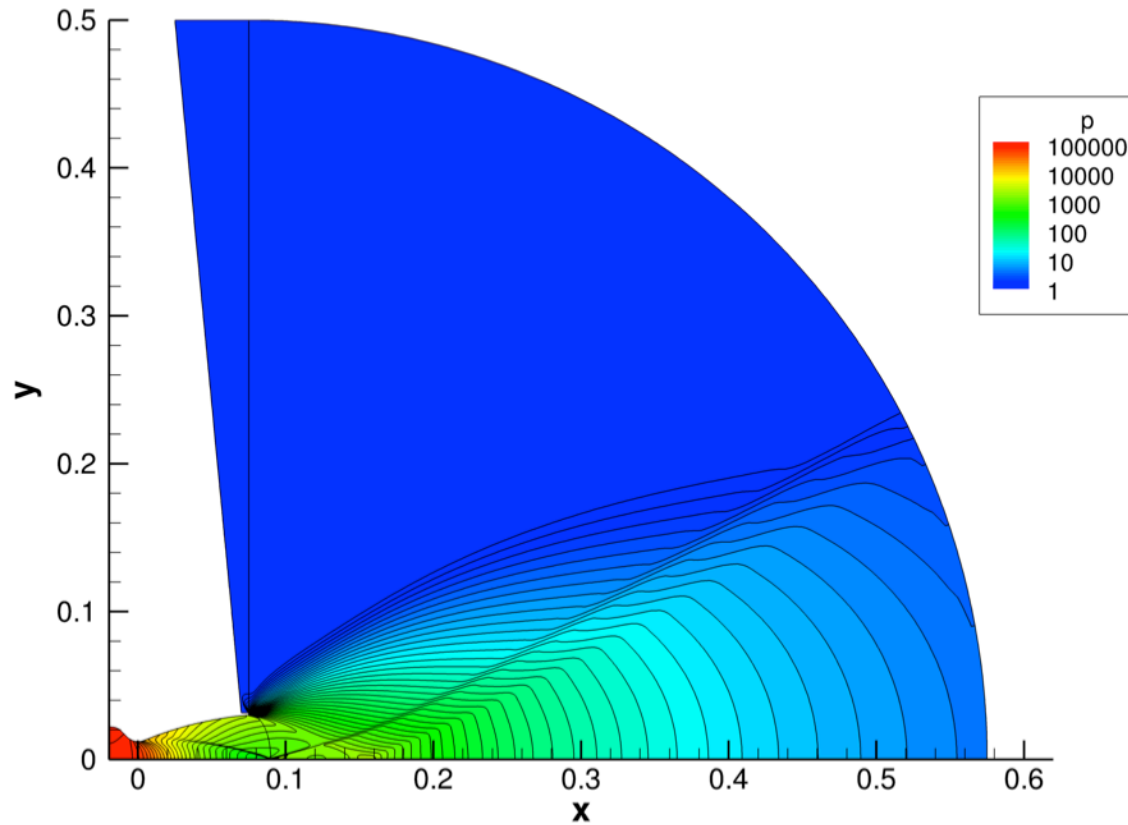

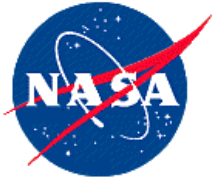

Inner DSMC Region Detailed Description



- 4.2 by 5.0 by 4.2 meters region containing DC1 and CFD derived in flow surfaces
- CFD surfaces placed upstream of any interactions with DC1 as required by this loosely coupled technique
 - Very near the 2×10^{22} number density value
- Very challenging problem due to the significant continuum nature of this region
 - Strong shock-shock interaction with DC1 geometry
 - Number densities about an order of magnitude higher in this area than on CFD inflow surface
 - Significant adaption required to remove simulation artifacts due to under resolved cell network
- Final simulation statistics
 - Target mean free path resolution: 8.0 MFP/cell
 - After two adaptations
 - 434 million cells, 15.95 billion molecules
 - Worst case cell resolution: 34.5 MFP/cell (due to small movement of shock-shock structure between adaptations)



CFD Result

Inner DSMC region boundary determination

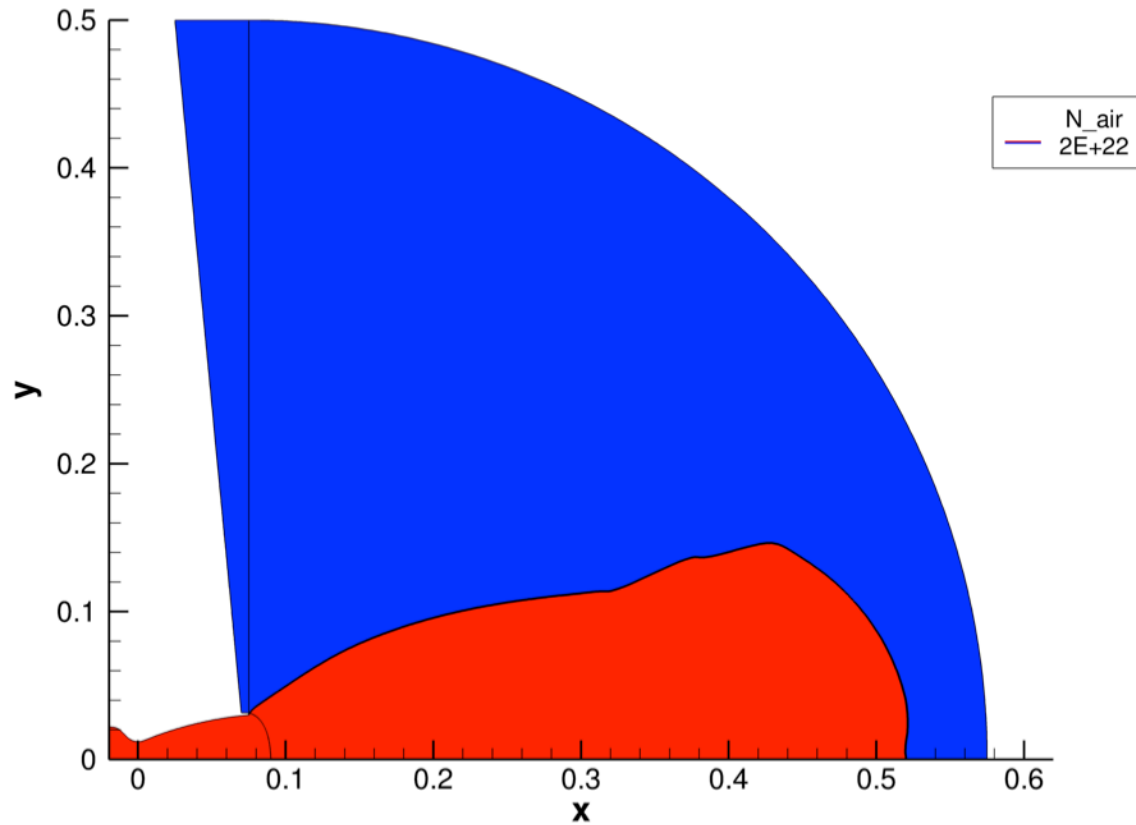



Inner DSMC Region In flow boundaries and DC1

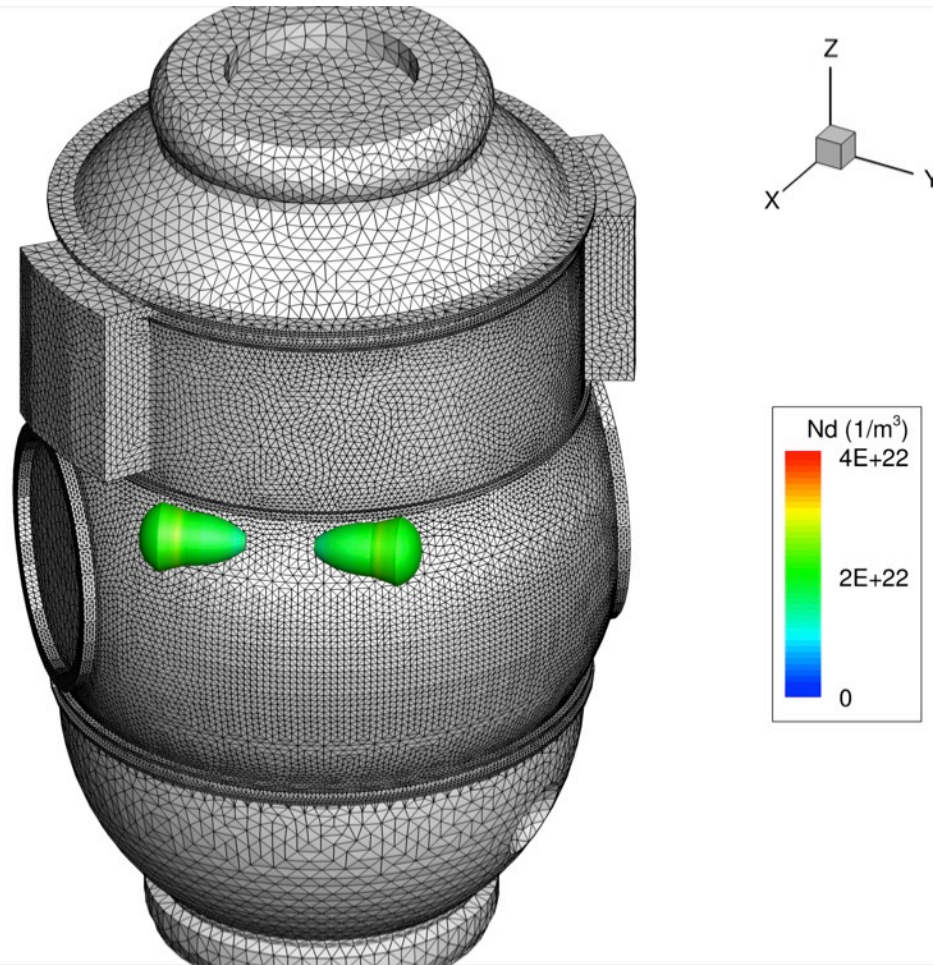



Inner DSMC Region Number Density Contours

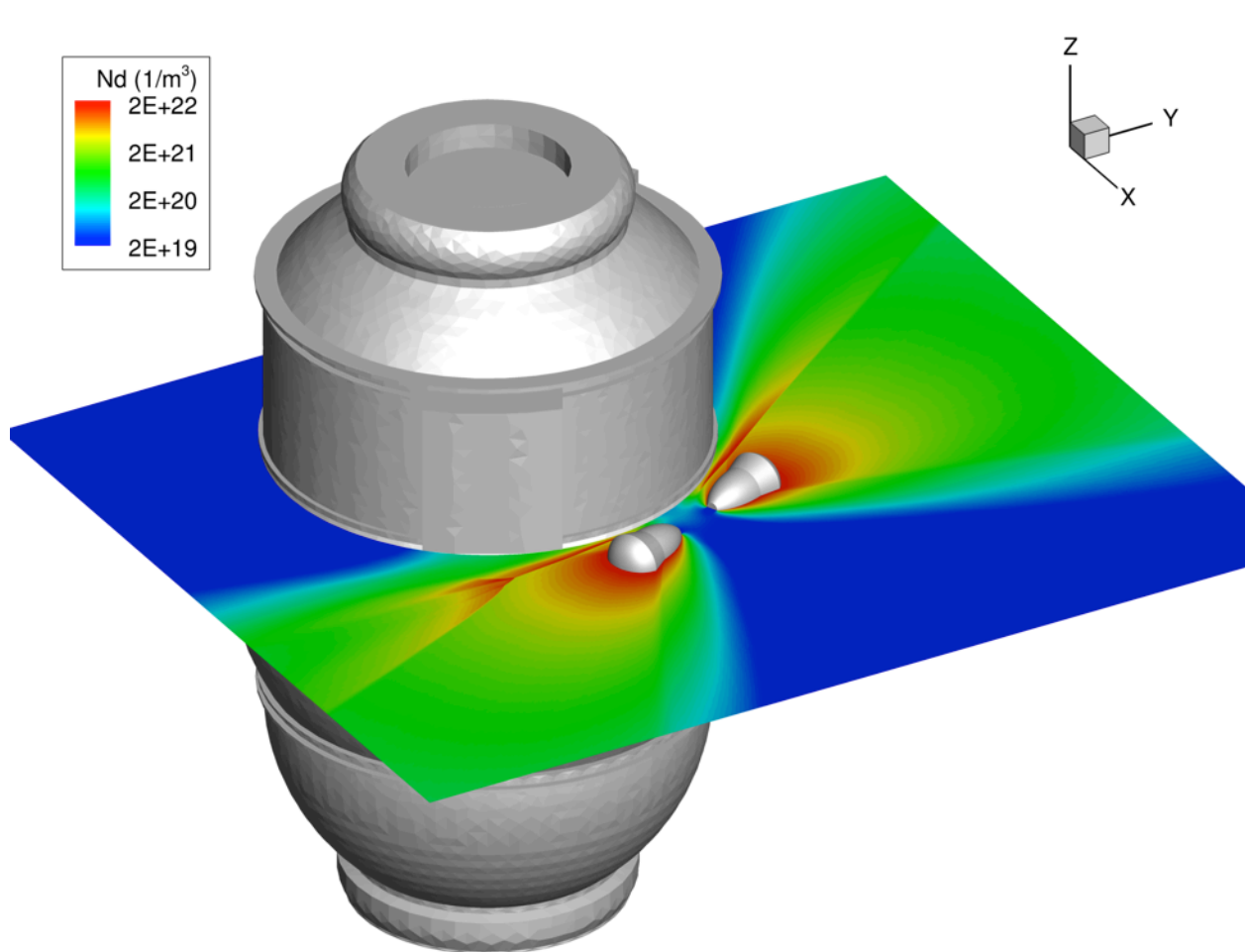



Inner DSMC Region Detail: Shock-Shock Interaction

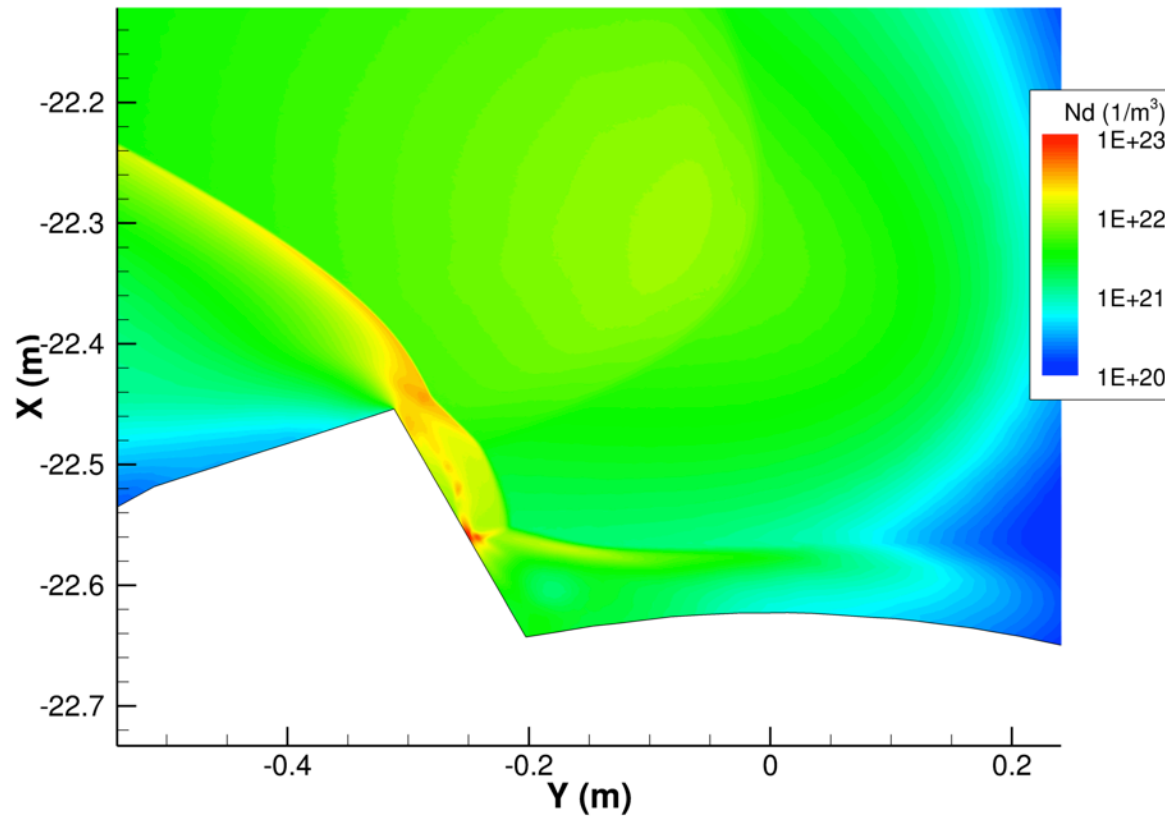



Inner DSMC Region

Surface Pressure Contours on DC1

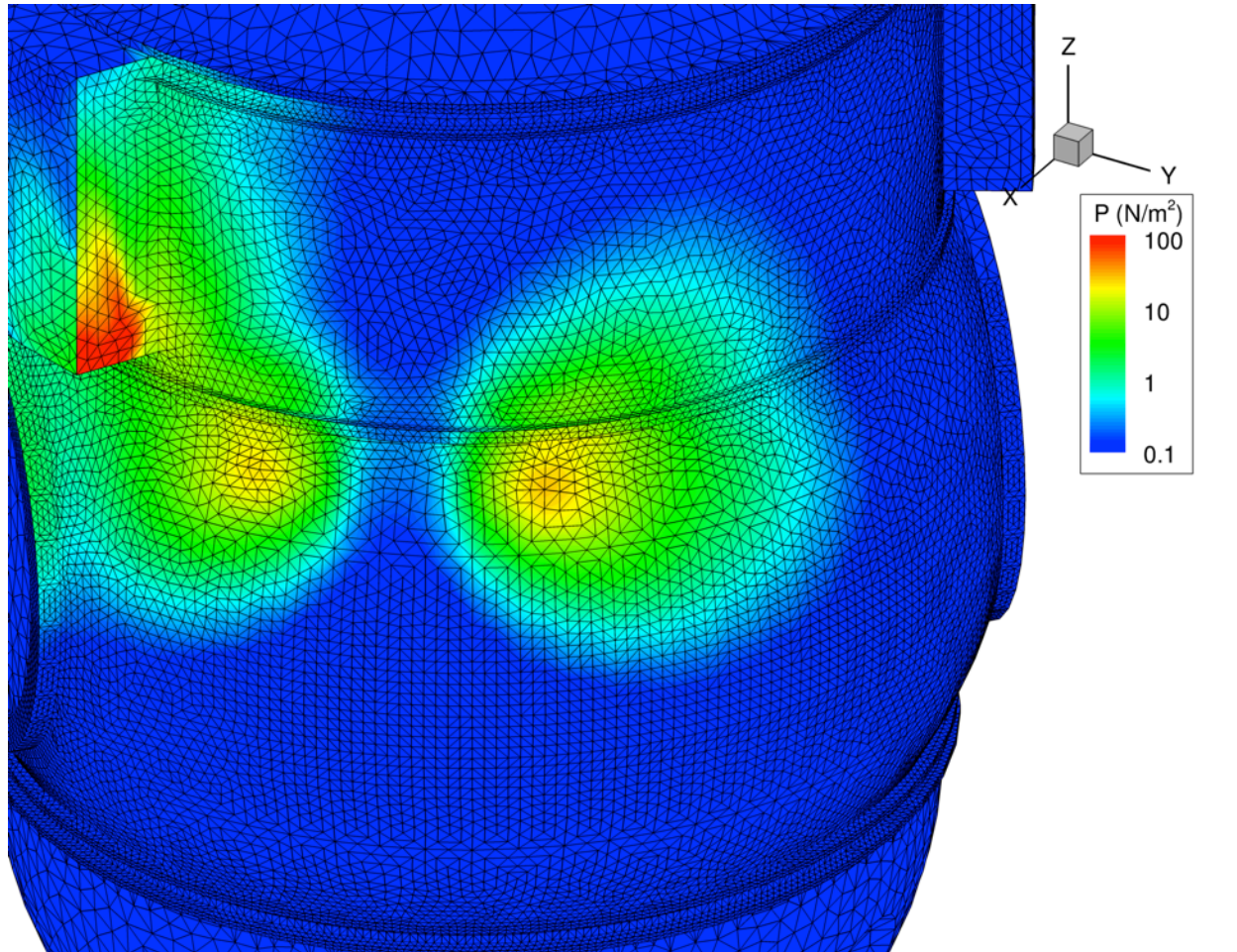

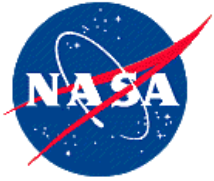

Outer DSMC Region Detailed Description



- A “rest of ISS” region typically about 60 by 102 by 74 meters in size
- In flow boundary attached to DC1
 - Hole cut in DC1 to attach in-flow boundary
 - Low density on in flow surface
 - Outward flow orientation on in flow surface
 - In-flow boundary reused for each “rest of ISS” case considered
- Several cases of ISS configuration considered
 - Varying SARJ, BGA, and TRRJ angles has significant effect on plume induced forces and moments
- Five cases presented: Cases 00, 01, 02, 07, 08
- Significantly less resources required
 - Target MFP resolution: 2.5 MFP/Cell
 - Typically 116 million cells, 1.67 billion molecules
 - Worst case cell resolution: 15.25 MFP/cell

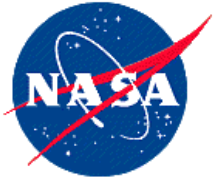

Outer DSMC Region

In flow boundary, Mean free path contours

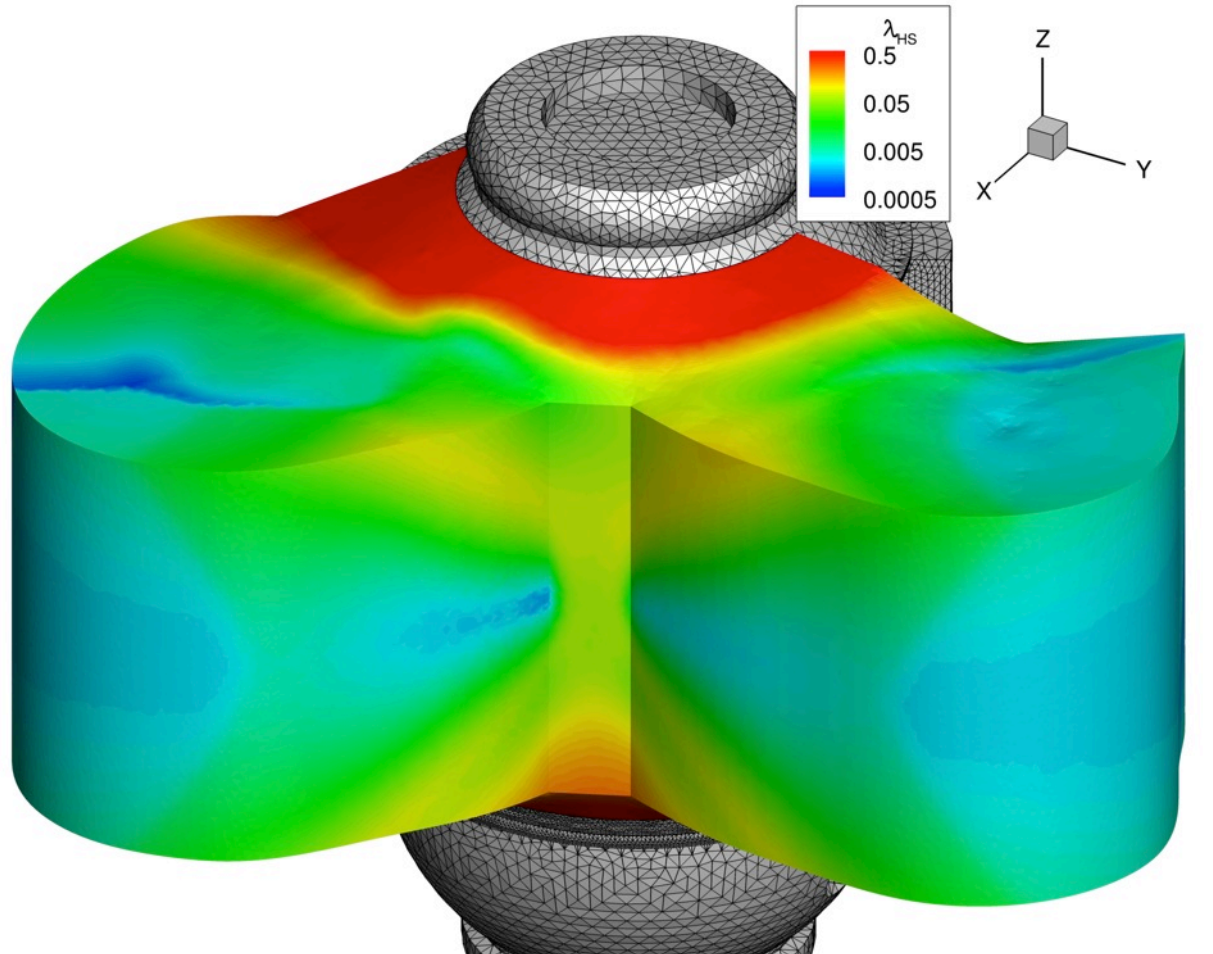

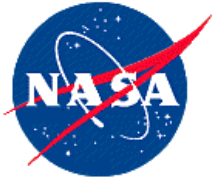

Case Matrix

(all angles in degrees)



Case	00	01	02	07	08
Port SARJ	0.0	270.0	270.0	270.0	270.0
2A BGA	0.0	35.0	-57.0	35.0	35.0
4A BGA	0.0	-35.0	-35.0	-35.0	-35.0
4B BGA	0.0	25.0	-66.0	25.0	25.0
2B BGA	0.0	-25.0	-25.0	-25.0	-25.0
Stbd SARJ	0.0	90.0	0.0	90.0	90.0
3A BGA	0.0	-35.0	0.0	-35.0	-35.0
1A BGA	0.0	35.0	0.0	35.0	35.0
1B BGA	0.0	-25.0	0.0	-25.0	-25.0
3B BGA	0.0	25.0	0.0	25.0	25.0
Port TRRJ	90.0	-40.0	27.3	27.3	27.3
Stbd TRRJ	90.0	25.0	90.0	25.0	90.0



Case 01 (Nominal)

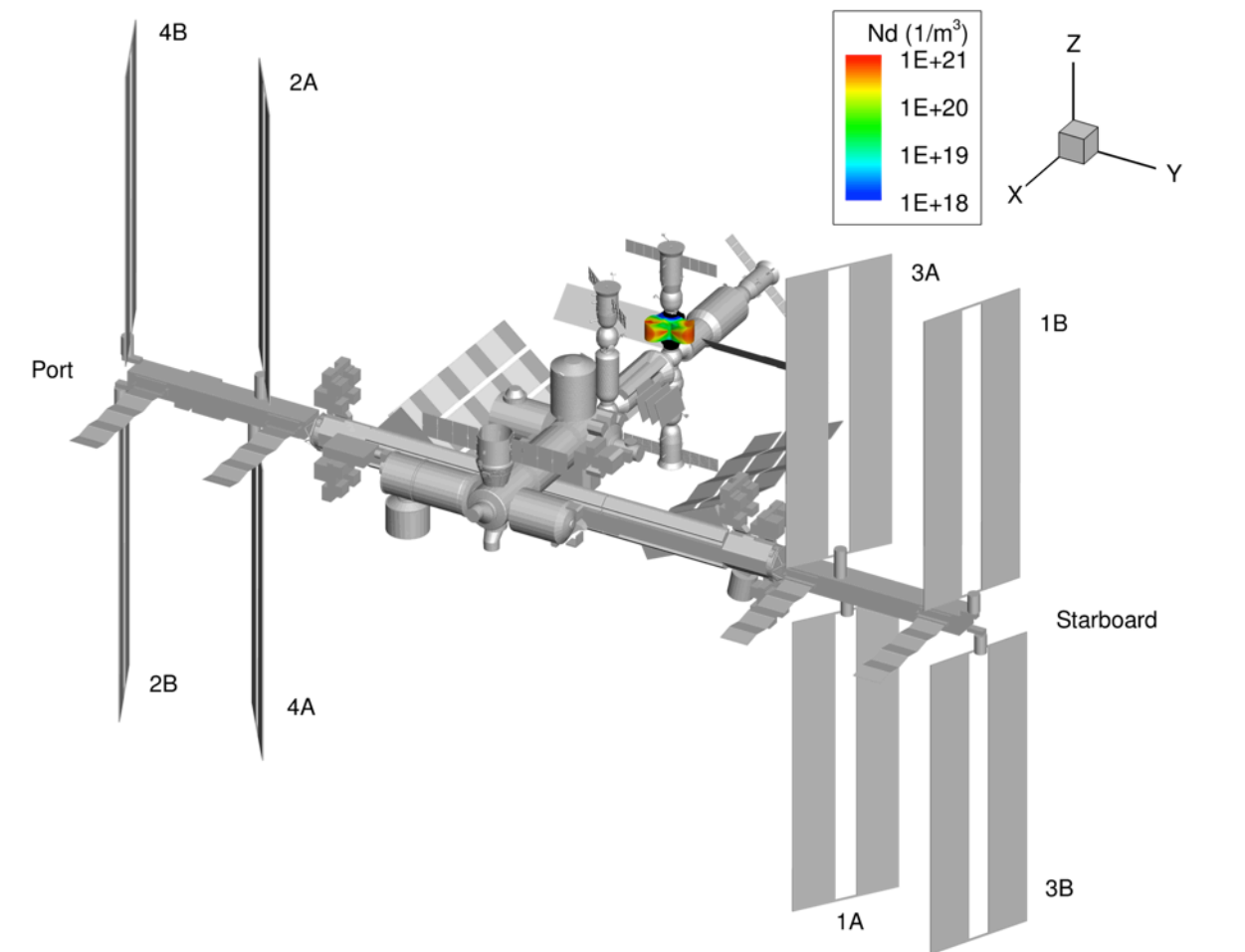



Case 08 (Recommended)

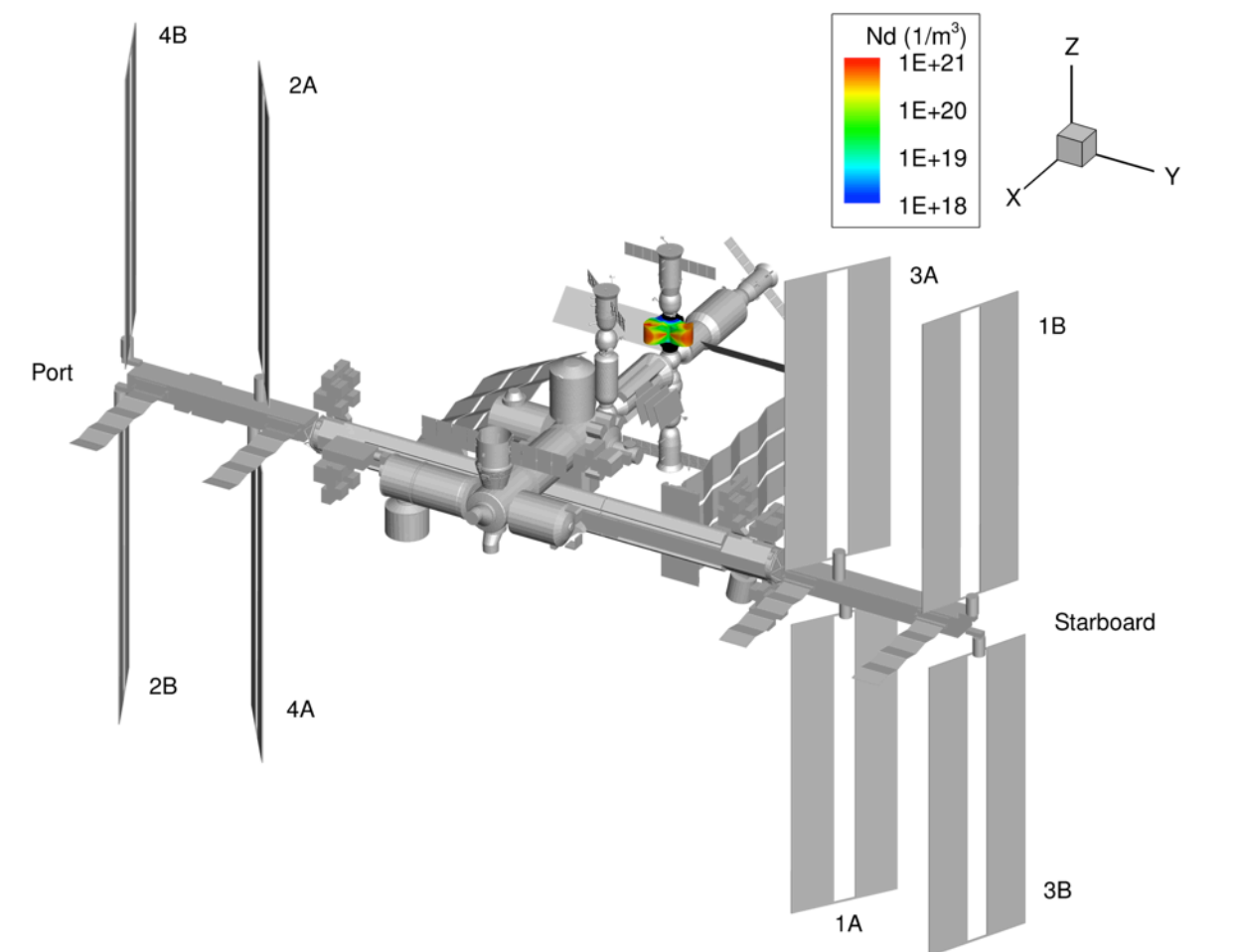



Summary Results



Case	F_x (N)	F_y (N)	F_z (N)	M_x (N-m)	M_y (N-m)	M_z (N-m)	M_{RSS} (N-m)
00	-1.899	-20.392	-6.938	35.256	-139.638	332.507	362.357
01	11.136	-29.801	-17.251	358.884	-121.382	596.805	706.900
02	2.377	-2.914	-5.425	37.964	-129.304	2.827	134.792
07	11.104	-21.840	-6.174	142.166	-31.224	511.848	532.142
08	11.261	-18.787	-4.504	167.441	-3.574	457.504	487.195



Case 01 - Detailed Results (Moments about ISS Center of Mass)



Component	F_x (N)	F_y (N)	F_z (N)	M_x (N-m)	M_y (N-m)	M_z (N-m)
DC1	-6.2920	-4.2977	-0.6316	18.92170	-41.76330	90.68420
ISS	4.8328	-1.0014	-1.4889	13.88010	-10.20550	48.56290
S. ETCS	0.2235	1.6502	-2.3515	-34.30960	-40.55680	-31.69610
P. ETCS	1.9239	-11.9524	-13.1666	161.42900	-168.01000	177.83800
SM Port SA	-0.1312	-0.0852	-0.1014	0.92074	-2.59169	0.99535
SM Stbd SA	-1.1361	0.7184	0.3039	2.00700	5.84919	-6.84133
Stbd USPV	0.8842	1.2579	0.0193	-4.17968	3.87634	-34.57710
Port USPV	10.8306	-16.0907	0.1652	200.21500	132.02000	351.83900
Total	11.1356	-29.8010	-17.2514	358.88426	-121.38176	596.80492



Case 08 - Detailed Results

(Moments about ISS Center of Mass)



Component	F_x (N)	F_y (N)	F_z (N)	M_x (N-m)	M_y (N-m)	M_z (N-m)
DC1	-6.292	-4.298	-0.632	18.922	-41.763	90.684
ISS	4.539	-1.948	-1.800	14.704	-12.665	49.303
Progress	-0.078	-0.001	0.111	0.084	1.600	0.076
S. ETCS	0.325	4.911	-0.695	-7.380	-12.647	-90.307
P. ETCS	0.772	-1.367	-1.000	9.650	-13.044	28.241
SM Port SA	-0.128	-0.086	-0.104	0.942	-2.644	1.059
SM Stbd SA	-1.134	0.717	0.303	2.003	5.832	-6.832
S4S6 Truss	0.048	0.021	-0.043	-1.548	0.024	-1.759
3A1B USPV	0.569	0.841	0.166	-4.819	7.363	-22.324
1A3B USPV	0.129	0.186	-0.090	-0.159	-2.359	-5.137
P4P6 Truss	1.644	-0.846	-0.901	28.429	-0.737	55.261
2A4B USPV	8.516	-13.262	1.461	121.347	108.246	274.356
4A2B USPV	2.352	-3.653	-1.280	-14.734	-40.778	84.882
Total	11.261	-18.787	-4.504	167.441	-3.574	457.504



Conclusions & Flight Results



- Challenging high fidelity simulation of plume impingement to ISS for a Russian EVA depressurization from DC1/Pirs has been accomplished.
 - Resulted in enhancements to JSC's DSMC code
 - Ability to perform problems with more than $2^{31}-1$ molecules
 - Ability to enhance refinement only near inflow surfaces (useful for initial DSMC run)
 - Found bug resulting in problems with more than about 8 million Level-I cells to fail at times
- ISS radiator and array orientations have a significant effect on the resulting plume impingement forces and moments.
 - As much as a factor of ~ 5.25 between Case 01 (nominal) and Case 02 (optimized)
 - With additional analysis, it could be possible to find an ISS configuration which results in zero plume impingement induced torques.
- Results for recommended case (Case 08) were analyzed by GN&C team
 - Number of CMG desaturations predicted was from 7-15 depending on GN&C assumptions
- EVA was performed on Aug. 10, 2015
 - Program allowed modification of nominal radiator settings but not nominal array settings
 - Radiator settings were near those recommended
 - Eight CMG desaturations occurred compared to GN&C preference of <15 .