

12-16 July 2015, Bellevue, Washington

Process Development for Removal of Siloxanes from ISS Atmosphere

Layne Carter¹ Jay Perry² and Matthew J. Kayatin³
NASA Marshall Space Flight Center

Mark Wilson⁴, Gregory J. Gentry⁵, and Elizabeth Bowman⁶
The Boeing Company

Oscar Monje⁷
NASA Kennedy Space Center

Tony Rector⁸ and John Steele⁹
United Technologies Aerospace Systems

Dimethylsilanediol (DMSD) has been identified as a problematic organic contaminant aboard the ISS. This contaminant was initially identified in humidity condensate and in the Water Processor Assembly (WPA) product water in 2010 when routine water quality monitoring an increasing total organic carbon (TOC) trend in the WPA product water. Although DMSD is not a crew health hazard at the levels observed in the product water, it can degrade the WPA catalytic reactor's effectiveness and cause early replacement of Multifiltration Beds. DMSD may also degrade the performance of the Oxygen Generation System (OGS) which uses the WPA product water for electrolysis. An investigation into the source of DMSD has determined that polydimethylsiloxane (PDMS) compounds are likely hydrolyzing in the Condensing Heat Exchangers (CHX) to form DMSD. PDMS compounds are prevalent aboard ISS from a variety of sources, including crew hygiene products, adhesives, caulks, lubricants, and various nonmetallic materials. PDMS compounds are also known to contribute to CHX hydrophilic coating degradation by rendering it hydrophobic and therefore adversely affecting its ability to effectively transmit water to the condensate bus. Eventually this loss in performance results in water droplets in the air flow exiting the CHX, which may lead to microbial growth in the air ducts and may impact the performance of downstream systems. Several options have been evaluated to address these concerns. Modifications to the Water Processor Multifiltration Beds and Catalytic Reactor for removal of DMSD were not considered viable, and did not address the issue with PDMS compound degradation of the CHX coating. Design concepts are now in development for removing PDMS compounds from the air stream before they can reach the CHX coating, thus preventing coating degradation and hydrolysis of the PDMS compounds to DMSD. This paper summarizes the current status of the effort to treat these contaminants on ISS.

¹ ISS Water Subsystem Manager, Space Systems Dept., NASA-MSFC/ES62.

² Lead Aerospace Engineer, Space Systems Dept., NASA-MSFC/ES62.

³ Aerospace Engineer, Space Systems Dept., NASA-MSFC/ES62.

⁴ Associate Technical Fellow, Boeing Research & Technology, 13100 Space Center Blvd., MC HB3-20, Houston, TX 77059.

⁵ Associate Technical Fellow & ISS ECLS Technical Lead, Boeing, 3700 Bay Area Boulevard, Houston TX 77058.

⁶ Lead Chemist & Technical Lead Engineer, Boeing Huntsville Laboratories, Boeing Research & Technology, 499 Boeing Blvd. JN-06, Huntsville, AL 35824.

⁷ Research Scientist, Vencore/EASI, ESC Contract, Kennedy Space Center, FL., 32899.

⁸ Staff Engineer, Hamilton Sundstrand Space Systems International, A UTC Aerospace Systems Company, 1 Hamilton Road, MS 1A-2-W66, Windsor Locks, CT 06096-1010.

⁹ Engineering Fellow, Hamilton Sundstrand Space Systems International, A UTC Aerospace Systems Company, 1 Hamilton Road, MS 1A-2- W66, Windsor Locks, CT 06096-1010.

Nomenclature

<i>BFE</i>	=	Bacteria Filter Elements
<i>CACEA</i>	=	Cabin Air Catalyst Element Assembly
<i>CCAA</i>	=	Common Cabin Air Assembly
<i>CDRA</i>	=	Carbon Dioxide Removal Assembly
<i>CFM</i>	=	cubic feet per minute
<i>CHX</i>	=	Condensing Heat Exchanger
<i>CRA</i>	=	Carbon Dioxide Reduction Assembly
<i>D3</i>	=	hexamethylcyclotrisiloxane
<i>D4</i>	=	octamethylcyclotetrasiloxane
<i>D5</i>	=	decamethylcyclopentasiloxane
<i>D6</i>	=	dodecamethylcyclohexasiloxane
<i>DMSD</i>	=	dimethylsilanediol
<i>ECLS</i>	=	Environmental Control and Life Support
<i>GCMS</i>	=	gas chromatography/mass spectrometry
<i>ISS</i>	=	International Space Station
<i>KSC</i>	=	Kennedy Space Center
<i>kPa</i>	=	kiloPascals
<i>L2</i>	=	hexamethyldisiloxane
<i>L3</i>	=	octamethyltrisiloxane
<i>L4</i>	=	decamethyltetrasiloxane
<i>L5</i>	=	dodecamethylpentasiloxane
<i>MF</i>	=	multifiltration
<i>MLS</i>	=	Mostly Liquid Separator
<i>MSFC</i>	=	Marshall Space Flight Center
<i>OGA</i>	=	Oxygen Generation Assembly
<i>PDMS</i>	=	polydimethylsiloxane
<i>psig</i>	=	pounds per square inch, gauge
<i>REMS</i>	=	Regenerative ECLS Module Simulator
<i>TCCS</i>	=	Trace Contaminant Control System
<i>TOC</i>	=	Total Organic Carbon
<i>TOCA</i>	=	Total Organic Carbon Analyzer
<i>UTAS</i>	=	United Technology Aerospace Systems
<i>UPA</i>	=	Urine Processor Assembly
<i>VOC</i>	=	volatile organic compound
<i>WPA</i>	=	Water Processor Assembly
<i>WRM</i>	=	Water Recovery and Management
<i>WRS</i>	=	Water Recovery System

I. Introduction

THE International Space Station (ISS) Water Recovery and Management (WRM) System produces potable water for crew drinking and hygiene, oxygen generation, urinal flush water, and payload use from crew urine, humidity condensate, and Sabatier product water. The Water Recovery System (WRS) is comprised of the Urine Processor Assembly (UPA) and Water Processor Assembly (WPA). This hardware was delivered to ISS on STS-126 on November 14, 2008 and has produced over 22890 kg of water as of May 18, 2015. The WPA product water is monitored weekly for Total Organic Carbon (TOC) by the on-orbit TOC Analyzer (TOCA) to insure the water meets ISS potable standards. Typically, the WPA product water has a TOC less than the TOCA detection limit, which is currently 285 µg/L. In June 2010, an increasing TOC trend in the WPA product water was detected by the TOCA. Analysis of the product water at the Johnson Space Center Environmental Laboratory operated by Wyle Analytical Services identified the source of the TOC as dimethylsilanediol (DMSD), an organosilicone compound that is not effectively removed by the WPA treatment process.

II. Overview of WRS and WPA

The ISS WRS provides the capability to receive the waste water on Ifrom various sources, process the waste water to potable standards via the WRS, and distribute potable water to users on the potable bus. A simplified functional schematic of the WRS is provided in Fig. 1. The waste water bus receives humidity condensate from the Common Cabin Air Assemblies (CCAAs) on ISS, which condenses water vapor and delivers the condensate to the waste water bus via a water separator. In addition, water is also received

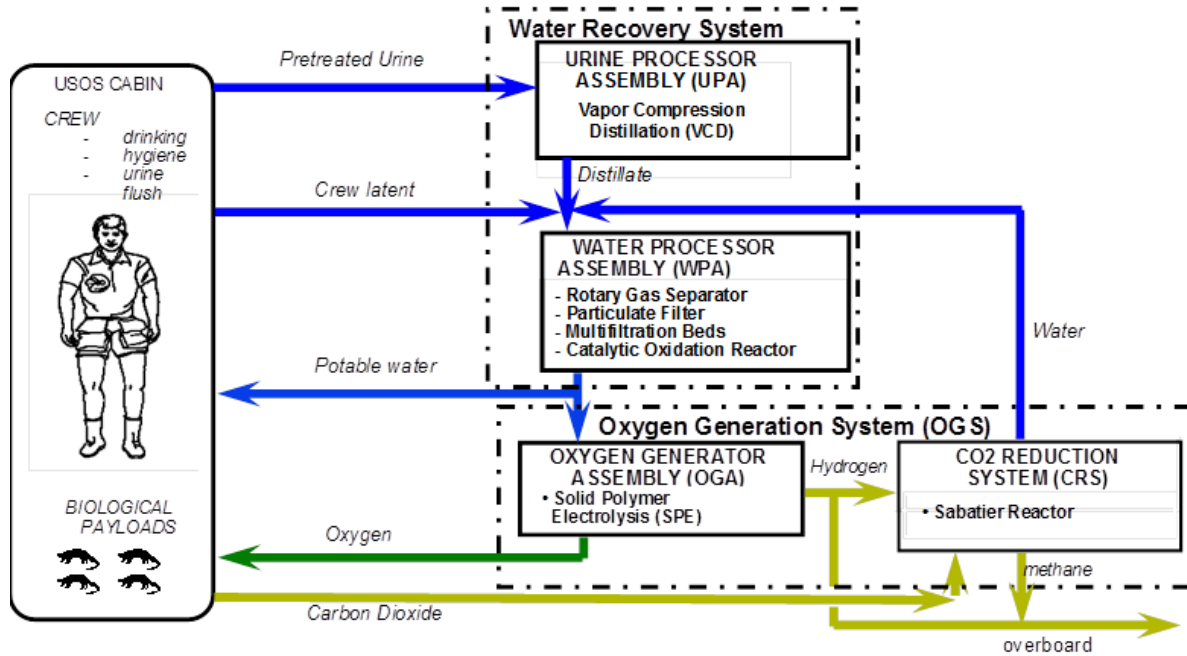

Figure 1. Water Recovery and Management Architecture for the ISS US Segment.

from the Carbon Dioxide Reduction Assembly (CRA). This hardware uses Sabatier reaction-based technology to produce water from carbon dioxide supplied by the Carbon Dioxide Removal Assembly (CDRA) and hydrogen supplied by the electrolysis process in the Oxygen Generation Assembly (OGA).

A simplified schematic of the WPA is provided in Fig. 2. Wastewater delivered to the WPA includes condensate from the CCAA, distillate from the UPA, and CRA-produced water. This wastewater is temporarily stored in the Waste Water Tank. The Waste Water Tank includes a bellows that maintains a pressure of approximately 5.2 – 15.5 kPa (0.75 to 2.25 psig) over the tank cycle, which serves to push water and gas into the Mostly Liquid Separator (MLS). Gas is removed from the wastewater by the MLS (part of the Pump/Separator assembly), and passes through the Separator Filter where odor-causing contaminants are removed from entrained air before returning the air to the cabin. Next, the water is pumped through the Particulate Filter followed by two Multifiltration (MF) Beds where inorganic and non-volatile organic contaminants are removed. Once breakthrough of the first bed is detected, the second bed is relocated into the first bed position, and a new second bed is installed. The Sensor assembly located between the two MF beds determines when the first bed is saturated based on conductivity. Following the MF Beds, the process water stream enters the Catalytic Reactor, where low molecular weight organics not removed by the adsorption process are oxidized in the presence of oxygen, elevated temperature, and a catalyst. A regenerative heat exchanger recovers heat from the catalytic reactor effluent water to make this process more efficient. The Gas Separator removes excess oxygen and gaseous oxidation by-products from the process water and returns it to the cabin. The Reactor Health Sensor monitors the conductivity of the reactor effluent as an indication of whether the organic load coming into the reactor is within the reactor's oxidative capacity. Finally, the Ion Exchange Bed removes dissolved products of oxidation and adds iodine for residual microbial control. The water is subsequently stored in the Water Storage Tank prior to delivery to the ISS potable water bus. The Water Delivery assembly contains a pump and small accumulator tank to deliver potable water on demand to users. The WPA is controlled by a firmware controller that provides the command control, excitation, monitoring, and data downlink for WPA sensors and effectors.

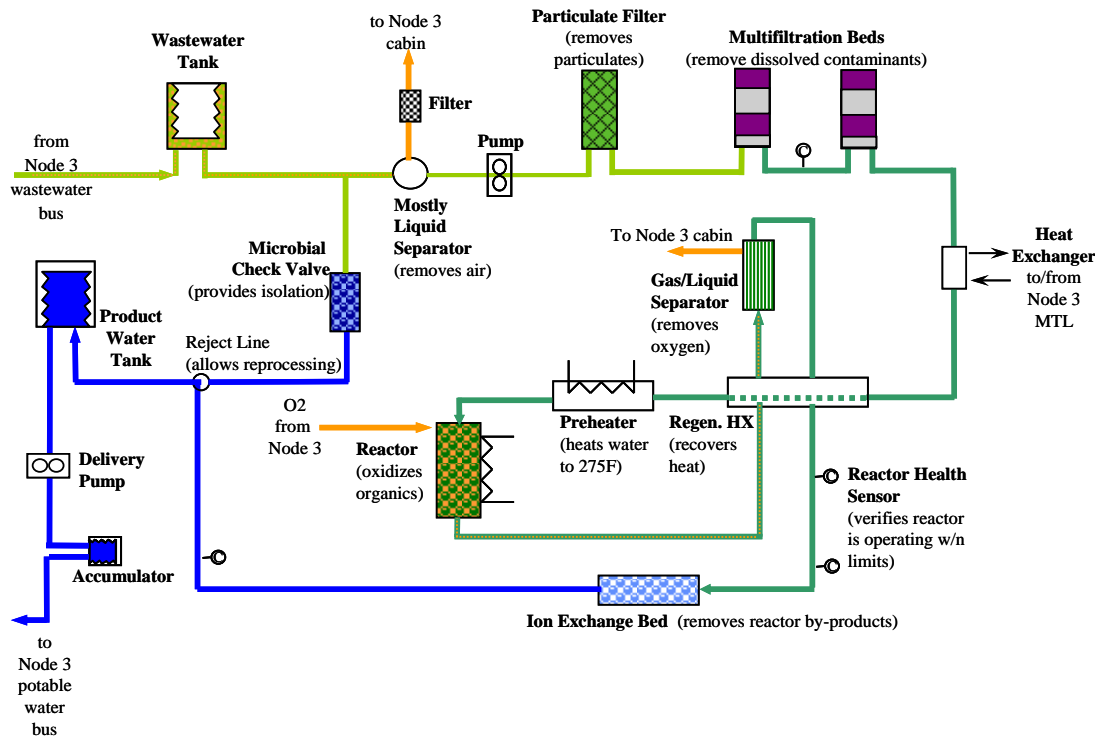

Figure 2. WPA simplified schematic.

III. DMSD Source Evaluation

A lengthy investigation by personnel from NASA, Wyle Analytical Services (Houston, Texas), Boeing, and United Technologies Aerospace Systems (UTAS, Windor Locks, Connecticut) determined that polydimethylsiloxane (PDMS) compounds, commonly referred to as siloxanes, which are prevalent in the ISS atmosphere are hydrolyzing to form DMSD. This reaction occurs primarily in the ISS Condensing Heat Exchanger (CHX) component of the CCAA which uses a hydrophilic coating comprised of various inorganic compounds to enhance condensate collection from the atmosphere on the heat exchange surfaces. However, the compounds in the coating also facilitate siloxane hydrolysis to DMSD in a mechanism similar to the hydrolysis of siloxanes in groundwater.^{1,2} Once DMSD is formed in the coating, it dissolves in the condensate which is transferred to the WPA for processing.

DMSD is polar with a partial ionic charge possesses a slight ionic charge and is therefore initially removed by the anion exchange resin in the WPA Multifiltration Beds. However, anions have a stronger affinity for the anion exchange resin than DMSD does resulting in anion displacement of the DMSD which ultimately passes through the Multifiltration Beds and enters the Catalytic Reactor. Based on ground tests, the Catalytic Reactor removes approximately 75% of the DMSD, with the remaining ~10 mg/L passed to the Ion Exchange Bed. As with the Multifiltration Bed, the DMSD eventually saturates the Ion Exchange Bed. At this point DMSD is present in the WPA product water, where the trend is initially detected by the TOCA during the weekly analysis. A detailed review of this process can be found in Ref. 3.

The technical challenge is that siloxanes are prevalent aboard ISS from a variety of sources, including crew hygiene products, adhesives, caulks, lubricants, and various other nonmetallic materials. From the beginning of crewed operations aboard the ISS, siloxanes have been reported in cabin air quality samples. Figure 3 shows the siloxane concentration trend from December 1998 through October 2014. Four compounds contribute to the load—hexamethylcyclotrisiloxane (D3), octamethylcyclotetrasiloxane (D4), decamethylcyclopentasiloxane (D5), and trimethylsilanol. Post-flight analysis of activated carbon used in the Trace Contaminant Control System (TCCS) has indicated thirteen siloxane and silane compounds were removed from the ISS cabin atmosphere.⁴ The dominant compounds were D4 and D5 siloxanes. The total siloxane concentration in the ISS cabin atmosphere is typically between 2 mg/m³ and 4 mg/m³. The valley between 2900 days and 4500 days in Figure 3 corresponds to the period between December 2006 and June 2011 when quantitative results for D3, D4, and D5 siloxanes were not reported in the grab sample analysis results. During this period, although quantitative results were reported for trimethylsilanol

only, D3, D4, and D5 siloxanes were noted to be qualitatively present; therefore, concentrations for these compounds are thought to be similar to levels reported before and after that period. This implies that the valley is due to the compounds measured and does not reflect a valley in total siloxane concentration. Higher concentrations are typically observed in cargo vehicle first entry samples and other volumes that have been isolated from active scrubbing for extended periods of time. As can be seen by Figure 3, the presence of siloxane compounds in the ISS cabin environment is not a new phenomenon but is a situation that consistently spans the entire period of crewed operations.

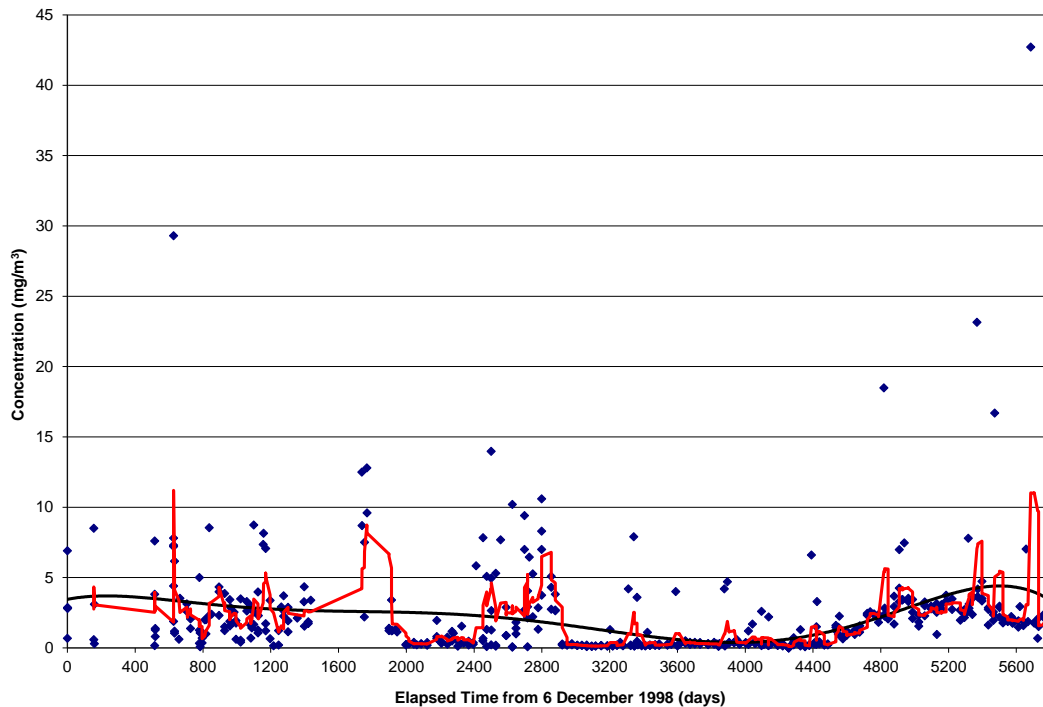

Figure 3. Siloxane concentrations in the ISS cabin atmosphere from December 1998 through October 2014. *The red line is a 5-period moving average and the black trend line is a sixth order polynomial fit.*

Once the source of DMSD was identified, concepts were developed to address the issue. Efforts initially focused on identifying media that could be added to the WPA Multifiltration Beds to remove DMSD. Unfortunately, this effort did not identify any adsorbents or other media that possessed significantly more capacity than the anion exchange resin in the Multifiltration Bed which was already known to be insufficient. Instead, engineering personnel determined the optimum approach would be to remove the siloxanes from the atmosphere before they could reach the CHX coating and hydrolyze to form DMSD. This approach has the added benefit of protecting the heat exchanger coating from contamination by siloxanes. This heat exchanger coating is known to degrade during its operational life on ISS as the coating's hydrophilic character degrades and, therefore, becoming less efficient in collecting water for transfer to the WPA. Previous analysis of a failed coating identified several primary contaminants that would impact the coating's hydrophilic nature, including various siloxanes, phthalate esters, and fatty acids. By adding a treatment process upstream of the heat exchanger that removes siloxanes and, potentially the other contaminants of concern, this solution is expected to also measurably improve the life of the CHX.

IV. A Research Plan for DMSD Mitigation

In 2014, personnel from NASA, Boeing, and UTAS began a research effort to further evaluate the mechanism by which DMSD is produced and the most effective design solution for siloxane removal from the air. This effort was led by Boeing as the ISS sustaining engineering organization and included initial tests at UTAS and the Marshall Space Flight Center (MSFC) to characterize the production of DMSD from various siloxanes followed by testing at the Kennedy Space Center (KSC) to quantify the capacity of various adsorbent media for airborne siloxane removal.

Finally, these data were used to develop a design concept for removing siloxanes from the ISS cabin atmosphere. The following discussion addresses each of these design efforts and summarizes the findings.

A. Research on Siloxane Interaction with Condensing Heat Exchanger Coating Materials

The primary objective of research conducted by UTAS was to determine if a correlation existed between test duration and DMSD formation under wet/dry conditions in the presence of powered hydrophilic coating. The hydrophilic coating utilized in the ISS CCAA CHX enhances the ability to collect humidity condensate, and also provides protection against microbial proliferation due to the presence of an inorganic biocide. This coating is made up of metal silicate materials similar to the clay materials known to catalyze the hydrolysis of siloxanes to DMSD. Furthermore, the hydrophilic coating contains fine particles of silica, a solid known to have a high affinity for siloxanes in air (up to 100 mg siloxane per gram of silica).⁵ Finally, a significant portion of the hydrophilic coating remains dry through the operational life of the CHX, thus providing the dry conditions that appear to enhance the catalytic hydrolytic effects of metal silicates on siloxanes resulting in the formation of DMSD. Previous solvent extractions conducted on a CHX that was operational on the ISS and was returned to ground due to the coating being hydrophobic showed the presence of significant amounts of siloxanes.⁶

Based on a review of the literature it is theorized that the ISS CCAA CHX captures siloxanes from the ISS air due to the fine particles of silica dispersed throughout the coating.⁷ It is further theorized that the trapped siloxanes are subsequently catalytically hydrolyzed by the hydrophilic coating metal silicates (clay-like constituents) to form DMSD (CH_2SiOH_2) according to the following reaction:

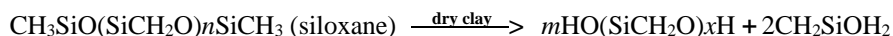

The resulting DMSD which is eventually carried to the humidity condensate waste bus and ultimately to the WPA. Initial laboratory tests at UTAS in 2013 demonstrated that one or more of the constituents in the hydrophilic coating act as a catalyst for the formation of DMSD from linear and cyclic siloxanes. Furthermore, this testing demonstrated that under dry conditions, the formation of DMSD from siloxanes was enhanced.

To develop a correlation between atmospheric siloxane concentrations and the concentration of DMSD in the humidity condensate from the CHX, a series of beaker tests were performed at UTAS. The tests consisted of individual beakers that contained 5.0 grams of powdered hydrophilic heat exchanger coating and then dosed with a mixture of PDMS presented in Table 1. The test consisted of five different siloxane concentrations (C1-C5) and were tested over five durations—7, 21, 35, and 48 days. Each test point had 24 individual beakers, with ten dry and ten wet at C1-C5 and four control samples of stainless steel wool and the C5 siloxane mixture. The beakers were either maintained dry or wet (with water) to reflect the ISS conditions of the heat exchanger coating. At the end of each test duration, the samples were extracted with deionized water followed by 0.1 N CaCl to extract any DMSD formed during the test period. Samples were then analyzed for DMSD at Wyle Analytical Services shown in Fig. 4.

Table 1. Siloxane compounds and respective mixture used in beaker study.

Siloxane Compound	Percent in Mixture	Total Siloxane Concentrations (mg)				
		<u>C1</u>	<u>C2</u>	<u>C3</u>	<u>C4</u>	<u>C5</u>
		0.234	1.25	2.5	5	10
D3 (Hexamethylcyclotrisiloxane)	42	0.090	0.525	1.050	2.10	4.2
D4 (Octamethylcyclotetrasiloxane)	4	0.009	0.050	0.100	0.20	0.4
D5 (Decamethylcyclopentasiloxane)	16	0.037	0.200	0.400	0.80	1.6
D6 (Dodecamethylcyclohexasiloxane)	2	0.004	0.025	0.050	0.10	0.2
L2 (Hexamethyldisiloxane)	9	0.021	0.112	0.225	0.45	0.9
L3 (Octamethyltrisiloxane)	9	0.021	0.112	0.225	0.45	0.9
L4 (Decamethyltetrasiloxane)	9	0.021	0.112	0.225	0.45	0.9
L5 (Dodecamethylpentasiloxane)	9	0.021	0.112	0.225	0.45	0.9

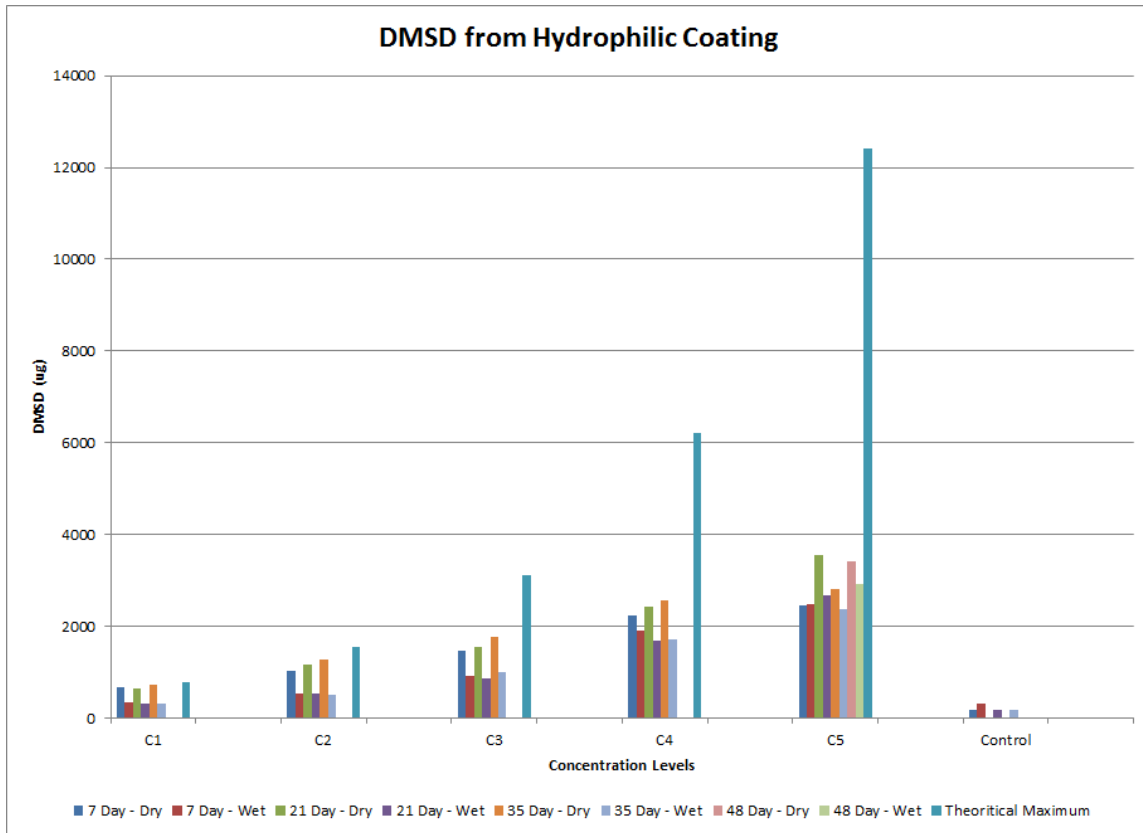

Figure 4. Results from UTAS DMSD/Hydrophilic Coating Beaker Studies.

A review of these data indicates the test duration did not impact the DMSD conversion, that dry coating produced significantly more yield of DMSD, and that higher concentrations of the siloxanes resulted in less theoretical yield to DMSD. After this test was completed, another test run was performed to evaluate DMSD conversion at higher siloxane concentrations that are expected to be more representative of instantaneous concentrations in the ISS cabin atmosphere. This test, however, did not result in any conversion of PDMS to DMSD likely due to the larger test beaker volumes used in the evaluation, the possibility that this test did not account for adsorbed siloxanes on the CHX coating, and possible inefficiencies in the DMSD extraction process.

Despite best efforts, the beaker level testing yielded inconclusive data as to a correlation between atmospheric concentration and the amount of DMSD in the humidity condensate. Upon further review of literature, it was determined that the exact reaction mechanism of the hydrolysis of PDMS to DMSD is not clearly understood. Studies indicated that the reaction rates for cyclic and linear siloxanes differ due to their structure and that in some cases DMSD can be reversibly converted back to parent siloxane compounds according to Refs. 1 and 2.

B. Research on the Influence of Atmospheric Siloxane Concentration on DMSD Loading in Condensate

Research conducted at MSFC aimed to quantify the influence of atmospheric siloxane concentration on humidity condensate DMSD loading. Testing was performed in the Regenerative Environmental Control and Life Support (ECLS) Module Simulator (REMS). The REMS is a 201 m³ aluminum chamber that has been previously used to produce human ersatz condensate. The REMS module includes an ISS flight-like CHX with hydrophilic coating acquired from UTAS, the flight hardware provider. This unit is operated consistent with ISS process conditions, including coolant temperature, coolant flow rate, and volumetric air flow rate. The module was sealed and pressurized to 0.3 inches H₂O over atmospheric pressure. Humidity injection was controlled to maintain a cabin relative humidity level consistent with ISS between 35% and 45% and the cabin temperature was kept near ambient.

The CHX was operated in one of two separate modes during testing, wet or dry. By controlling the incoming coolant temperature setpoint, the CHX surface temperature was either held below the cabin dew point (wet mode) or raised to near ambient temperatures above the dew point (dry mode). The coolant setpoints were 3 °C and 18 °C for wet and dry modes, respectively. REMS chamber dewpoints fluctuated with the internal chamber air temperature.

Various volatile (linear and cyclic) siloxanes were gravimetrically dosed into the REMS atmosphere in accordance with Table 2. Testing was conducted over two load stages, Stage 1 and Stage 2. Each stage was comprised of two test cycles. Cycles were 16-20 days in length with the CHX operating in wet mode over this time. Stage 1 test cycles (Cycle 1 and 2) were both conducted at 100% atmospheric siloxane loading. The PDMS concentration was then reduced in Stage 2 to determine if there was an effect, and to what extent, on the DMSD concentration in the condensate. Stage 2 test cycles (Cycle 3 and 4) were held at 50% of the Stage 1 atmospheric siloxane loading. Between each test cycle the CHX was operated in a dry-out mode for 72 hours. This dry-out is consistent with ISS operations performed to minimize microbial growth on the heat exchanger's surfaces. Following a dry-out, the CHX was returned to a wet mode followed by condensate sampling 24 hours into water production. Condensate was also monitored by weekly scheduled 24-hr aggregate sampling.

Table 2. REMS Atmospheric Siloxane Target Loading.

Compound	Abbreviation	Stage 1 [mg/m ³]	Stage 2 [mg/m ³]
Hexamethylcyclotrisiloxane	D3	2.1	1.05
Octamethylcyclotetrasiloxane	D4	0.2	0.1
Decamethylcyclopentasiloxane	D5	0.8	0.4
Dodecamethylcyclohexasiloxane	D6	0.1	0.05
Hexamethyldisiloxane	L2	0.45	0.22
Octamethyltrisiloxane	L3	0.45	0.22
Decamethyltetrasiloxane	L4	0.45	0.22
Dodecamethylpentasiloxane	L5	0.45	0.22

The REMS atmosphere was monitored by gas chromatography/mass spectrometry (GCMS) using an Agilent 7890A gas chromatograph coupled with an Agilent 5975C mass selective detector to ensure PDMS concentrations were maintained within 10% of the loads specified in Table 2. Sampled REMS atmosphere was pre-concentrated using a GCMS integrated cryogenic thermal desorption system (Gerstel) via closed-loop sampling. Based on the GCMS results, additional PDMS was dosed into the REMS atmosphere as needed. Typically, two GCMS analyses were completed each week. Condensate samples were analyzed by the Wyle Environmental Lab for DMSD. Note that the DMSD method detection limit (MDL) was defined by Wyle Labs to be 0.5 ppm (500 µg/L).

A summary of the REMS chamber post-dry-out condensate data is provided in Table 3. Shown are the duration of each cycle, the DMSD loading in the condensate, and the mass/volume of condensate produced. Previous REMS testing in 2013, and beaker-scale testing at UTAS, has shown enhanced production of DMSD from volatile siloxanes when exposed to a dry hydrophilic CHX coating. Thus, the detection of DMSD was expected for these post-dry-out test days. As will be discussed in subsequent sections, Cycle 1 was unable to sustain CHX wet mode operation. Furthermore, the condensate sampling did not coincide with a 24-hr aggregate sample. Therefore, this data point (Day 25) was excluded from the air to water loading correlation analysis. Overall, the loading of DMSD in the condensate did not correlate with the atmospheric PDMS loading. Excluding Cycle 1 results, the DMSD loading appeared to be increased in Stage 2, an unexpected result.

Table 3. Post-dry-out REMS DMSD condensate results and aggregate 24 hr mass/volume of liquid collected. [†]Cycle 1 sample did not meet test requirements; mass of water estimated from test data.

Stage	Cycle	Test Day	Days Wet	DMSD [µg/L]	Mass [lb]	Volume [L]
1	1	25	20	2,300	17.6 [†]	7.98
	2	47	18	1,100	23.7	10.75
2	3	68	17	2,000	13.1	5.94
	4	92	20	1,600	17.1	7.76

Based on the unanticipated post-dry-out condensate loading trend, the weekly scheduled condensate test results and facility datasets were further scrutinized. Unfortunately, it was determined that the test was impacted by the environmental temperature of the test facility, which varied significantly during the last two months of the test because of the season (winter) and facility maintenance being performed, preventing adequate thermal control. Unexpected temperature swings resulted in unplanned CHX dry-out events resulting from either low relative

humidity (humidity injection rate limited) or from a plunging dew point below CHX surface temperature. In total 15 of these dry-out events were observed; of these 15 events, 5 were followed by scheduled condensate sampling. Figure 5 displays all condensate results for both weekly and CHX post-dry-out sampling. Additional information of interest such as aggregate condensate mass and length of the dry-out event are displayed above each data point. Only in one case (the longest dry-out, Day 28) was DMSD detected. This case was caused by low relative humidity in the chamber over a 15 hr period with only a small total mass of condensate collected (3.5 lb). Two other long duration unplanned dry-outs occurred on Day 63 and Day 84 (7.5 hr and 3 hr, respectively) followed by condensate sampling; DMSD was not detected in either sample, however. Furthermore, in both cases a significant amount of condensate was collected (10 lb and 27.1 lb). It was hypothesized that these higher condensate levels might have diluted DMSD coming off the CHX.

In order to determine the feasibility of DMSD dilution, the Day 28 event was further scrutinized. Day 28 produced 1,200 µg/L of DMSD over a 15 hr period in 3.5 lb of water (1,588 mL). The mass of DMSD in the condensate was therefore 1,906 µg of chemical. Hypothetically, if this DMSD mass was diluted to the Wyle Labs DMSD detection limit, a condensate critical mass of 8.4 lbs of water (3.81 L) can be found. Thus, it was feasible that dilution could have masked DMSD in the Day 63 and Day 84 samples which were shorter duration unplanned dry-out events having condensate masses in excess of the critical mass/volume. These shorter dry-out events may have produced small enough amounts of DMSD that resulted in concentrations in the 24-hour condensate samples below the limit of detection.

Of particular importance for interpretation of test data was the potential impact an unplanned dry-out event had on the planned 72 hr dry-outs highlighted in Table 3. To estimate the impact the Day 28 event might have had on the planned Cycle 2, Day 47 dry-out, it was assumed that all DMSD produced by the unplanned dry-out would have otherwise transferred to the Day 47 condensate sample. If the 1,906 µg of DMSD given off during Day 28's unplanned dry-out was passed to the Day 47 sample, an increase from the reported 1,100 µg/L concentration to 1,277 µg/L was expected. Note that this value was still lower than the Cycle 3 & 4 one-half siloxane loading planned dry-out samples (Day 68 and 92). Although not classified as a dry-out event, to further support the argument of DMSD dilution, the Day 7 residual sample from Cycle 1 was examined for comparison. Day 7's sample was characterized by a small condensate tank mass (2.6 lb) and high DMSD level of 1,700 µg/L. This is equivalent to 2,004 µg of DMSD which when diluted with the critical mass of water described above results in a DMSD level near the detection limit (526 µg/L). Furthermore, the Day 63 event had ideal conditions for producing DMSD over a 7.5 hr dry-out period but the condensate mass at this time (10 lb) was exceeding the theoretical critical level for dilution and DMSD was not detected. Therefore, based on the preceding discussion, the unplanned dry-outs appear to produce DMSD but not much total mass and thus do not appear to impact the DMSD data trends.

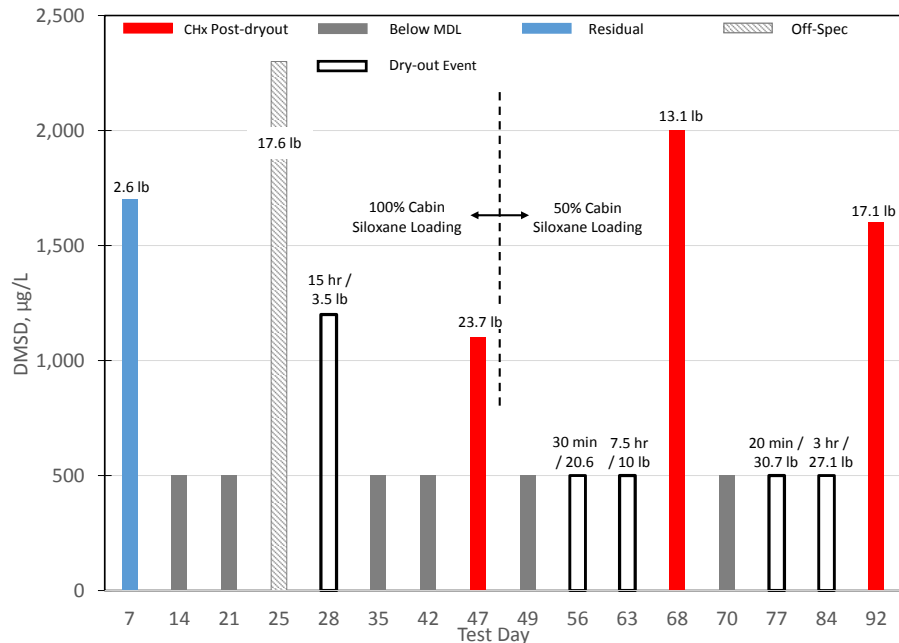

Figure 5. REMS condensate test results. Aggregate condensate mass and/or dry-out event time displayed above samples of interest. Results not reported below the detection limit of 0.5 ppm.

The idea of collected condensate levels impacting DMSD detection from unplanned dry-out events motivated more thought into the four planned post-dry-out event aggregate condensate samples. Due to uncontrollable temperature swings in the lab from building construction, the mean chamber temperature in Cycles 3 and 4 was less than that of Cycles 1 and 2. These lower temperatures translated to a reduced capacity for REMS cabin air to hold water. As shown by Table 3, the observed result was less condensate mass collected in post-dry-out aggregate condensate samples for Stage 2.

There are two general possibilities for the DMSD washout concentration profile from the CHX surface upon wetting—burst or continuous. A burst washout profile is characterized by a large amount of DMSD produced initially followed by some reduction in the rate or the completion of DMSD evolution with continued washing. A continuous washout profile is characterized by maintained production rates of DMSD over time. Flowing to an aggregate condensate collection tank, a continuous profile would produce a tank concentration of DMSD identical to that measured in the REMS condensate stream. Conversely, a burst washout profile would produce some time-dependent tank concentration based on concentration weighted by volume delivered. With regard to the idea of DMSD dilution in unplanned dry-out samples, a hypothetical burst profile that drops to low (or none) DMSD production rates over time (< 24 hr) would have a diluting effect over later collection times.

The true CHX washout profile characteristics for DMSD post-dry-out were not characterized at the time of this testing. Therefore, the interpretation of the results comparing the atmospheric loading of DMSD in cabin air to humidity condensate took into account both washout profile possibilities in order to bracket conclusions around these arguments. Due to the test sampling requirements, the DMSD results presented by Fig. 6 are already in agreement with a continuous washout profile. For the burst washout, the tank volumes shown by Table 3 were used to adjust DMSD levels from Day 68 and Day 92. The hypothetical dilution of these two condensate samples by an equivalent mass of water present in Cycle 2 (23.7 lb) adjusts the DMSD results as shown by Table 4. Pure water dilution provides a conservative result with the most aggressive dilution effect possible.

Table 4. Potential effect of CHX washout profile on DMSD loading. Mean data is shown \pm the standard deviation. “Continuous” profile is equivalent to 24 hr aggregate test data. [†]Cycle 1 could not be included in the mean sample data due to facility conditions.

Cycle	DMSD [$\mu\text{g/L}$]		STAGE #	MEAN [$\mu\text{g/L}$]	
	Continuous	Burst		Continuous	Burst
1 [†]	2,300	1,707	1	1,100	1,100
2	1,100	1,100			
3	2,000	1,105	2	1,800 \pm 283	1,130 \pm 35
4	1,600	1,155			

As shown by Table 4, the mean condensate DMSD loading values were not reduced by halving the atmospheric loading of siloxanes for either washout profile. DMSD production clearly increased for the continuous profile and remained nearly the same for the burst washout. This result may be due to the single sample size of Stage 1. Nonetheless, the results likely indicate that direct air to condensate mass transfer kinetics were not a dominant mechanism in DMSD production during REMS testing. Note that regular CHX fouling has been observed on orbit as described by Ref. 3 and combined with the REMS results support a DMSD production mechanism where surface accumulation and adsorption of siloxanes and not air-to-liquid mass transfer was the dominant physical phenomenon. The time or volume of condensate required for washing of the CHX to a clean surface and the DMSD producing compound’s persistence within the fouling is unknown. Therefore, it is possible that PDMS carryover was controlling DMSD production in REMS testing. If the rate of CHX PDMS adsorption is not slowed to lower the surface accumulation loading below the washout mass conversion then no effect on DMSD loading would be observed. Therefore, a critical cabin siloxane vapor concentration may exist above which no change in condensate DMSD production would be observed. Preventing all siloxanes from reaching the CHX may be the only certain solution. In support of these arguments, previous mass-transfer analysis of problematic compounds thought to contribute to CHX fouling did not show agreement between ISS cabin load levels and condensate loadings using Henry’s law co-current absorption models.⁸

It is noteworthy that all condensate data generated herein showed DMSD levels to be one order of magnitude less than those found in-flight. The source of this discrepancy is unknown. REMS testing in 2013 showed a mean DMSD level of 3,500 $\mu\text{g/L}$ but the dry-out cycles were much longer (1 month) than the current 2014 testing (3 days).

After completion of Cycle 4 testing, the REMS was vented by forced air, checked by GCMS, and repeated as needed to clean the chamber of siloxanes below the GCMS detection limits. All facility systems continued to operate and produce humidity condensate during this time. Weekly water sampling was continued. Two observed events during this clean phase were of particular interest to the analysis. First, due to a metering valve clog an unplanned dry-out even was observed in a clean atmosphere. This event was purposely extended to last 3 days followed by a 24 hour condensate aggregate sample (12/4/14, noon; Day 112). Immediately afterwards, a normal 3 day dry-out was commenced followed by aggregate condensate sampling (12/9/14, 10:30 AM; Day 117). The main difference between these events was the CHX coolant temperature. During the unplanned event/valve failure the coolant was maintained at approximately 3 °C whereas the normal dry-out utilized an 18 °C coolant temperature. Following the unplanned event, DMSD was found within the Day 112 condensate sample below the detection limit. Note that Wyle indicated that the concentration was close to MDL at 400 µg/L. The sample was taken from 13.41 L of condensate. Following the normal dry-out procedure, DMSD was detected on Day 117 at 920 µg/L in 5.11 L of condensate. Compared to the Cycle 3 & 4 data the post-dry-out DMSD levels are trending down possibly indicating the CHX surface is becoming cleaner with time. While it appears that the Day 117 warm coolant dry-out produced more DMSD, diluting the 920 µg/L sample to the Day 112 condensate volume of 13.41 L results in a similar sub-MDL level of 350 µg/L. Without understanding the washout profile the result from clean chamber testing was ambiguous due to different collected condensate volumes resulting from uncontrollable high-bay air temperatures.

In order to characterize the true CHX DMSD post-dry-out washout profile two experiments were planned. First, the REMS was operated in condensing mode for one week's time. Next, a baseline condensate sample was collected following a 72 hr dry-out. Unlike previous testing, the condensate sampling was taken incrementally which included detailed sampling every 15 minutes for the first hour followed by 2, 4, and 24 hour samples. For each sample the condensate volume or mass was recorded in order to construct a 24 hr aggregate sample by analysis of the DMSD chemical loading in each aliquot. Immediately following the baseline sample collection, D3 siloxane (210 mg) was dosed into the REMS to match the Stage 2 testing D3 level in the cabin. Previous characterization of the REMS leak rate resulted in an anticipated 15% atmospheric chemical loading decay rate per day. Therefore, a D3 (93 mg) maintenance dose was added co-current with the start of the CHX dry-out (3 days wet, 3 days dry) to maintain atmospheric levels consistent with the previous test's requirements. Samples were analyzed by Boeing Laboratories (Huntsville, Alabama) which reported a DMSD detection limit of 0.23 ppm.

Figure 6 displays the 1, 2, 4, and 24 overall DMSD loading for each experiment. The dotted line represents the DMSD detection limit. Clearly, the CHX washout profile follows the burst rather than continuous profile. In addition, the loading of DMSD in the condensate was elevated over all times when D3 was present in the cabin atmosphere. Note that for both samples the 24 hr aggregate DMSD levels were below method detection limits. This is a significant result supporting DMSD dilution over time with a CHX washout. Figure 7 displays the first hour of washout in 15-minute increments for both experiments. Initial DMSD condensate levels were nearly double that of those produced at the first hour. From these data the first two hours of washout appear to contain the most concentrated levels of DMSD. The early loading of condensate might offer a potential operational approach to mitigation of WPA loading on ISS by sequestering some amount of initial condensate produced.

Examining the difference in condensate loading between the baseline and D3 dosed atmosphere reveals an increase in DMSD production of only 1,165 µg. Out of the total 303 mg of D3 injected the conversion to DMSD is merely 0.38 wt. % (0.93 mol %) was converted to DMSD on a DMSD to D3 mass basis. Using the target atmospheric concentration as a mean mass basis instead we find conversion to DMSD at only 0.55 wt. %. If we assume that all of the 1,165 µg of DMSD produced in this experiment resulted from atmospheric D3 adsorption during this test phase then we find a mean CHX D3 to DMSD conversion rate of 191 µg/day. Although it is not believed that direct air to water mass transfer is the mechanism of loading, it is instructive to threshold the critical cabin concentration of D3 in this hypothetical scenario. Assuming this empirical production rate to be the rate limiting step in DMSD production and assuming a worst case scenario where every 1 mole of D3 results in 3 moles of DMSD, then based on the REMS ventilation flowrate through the CHX (500 cfm) the critical loading D3 must fall below is 7.5 ng/m³. Due to the infinitesimal magnitude of this concentration, complete PDMS scrubbing upstream of the CHX is the most promising solution for all mass transfer (direct vs fouling) scenarios.

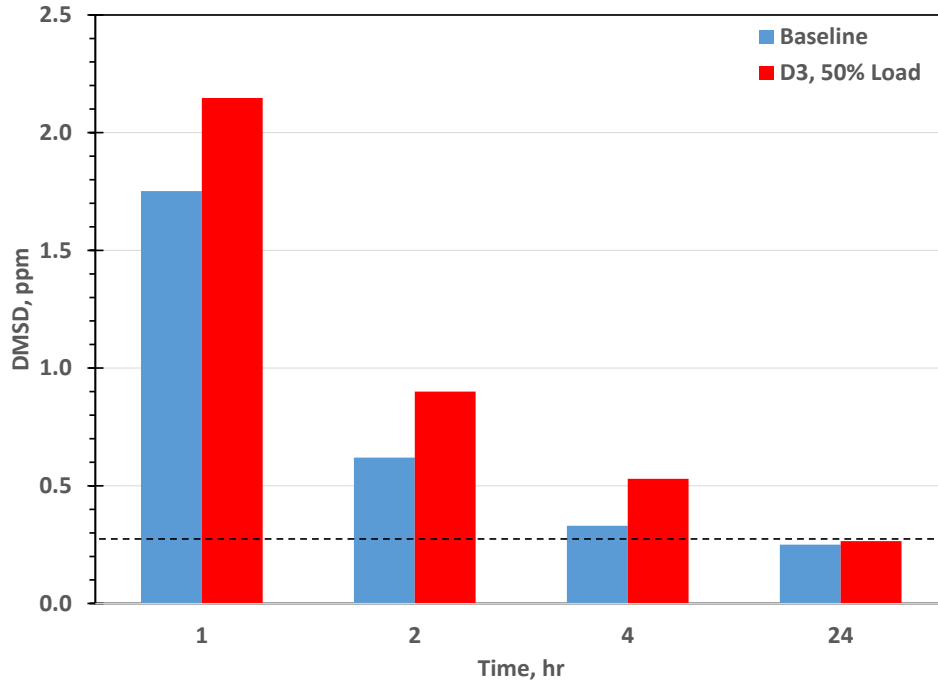

Figure 6. Measured REMS CHX post-dryout washout profile for a clean, baseline atmosphere vs. that of a Stage 2 equivalent D3 siloxane atmospheric load.

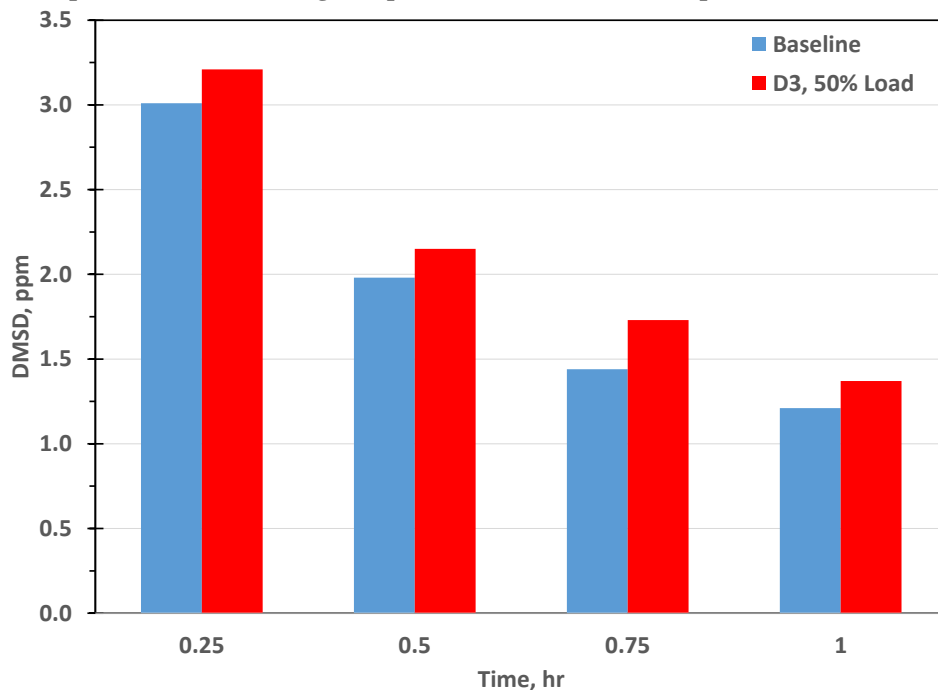

Figure 7. Detailed first hour of REMS CHX post-dryout washout profile for a clean, baseline atmosphere vs. that of a Stage 2 equivalent D3 siloxane atmospheric load.

C. Research on Gas Phase Siloxane Adsorbent Media

Research performed by KSC evaluated eleven candidate media for siloxane removal. Figure 8 shows the test rig used for this effort. The methodology was designed to measure adsorption capacities for a linear and a cyclic siloxane in humid gas streams. Hexamethyldisiloxane (L2) and hexamethylcyclotrisiloxane (D3) were selected for the testing. The siloxane concentrations and flow rates were chosen so that the adsorptive capacity of each sorbent could be obtained within 48 hrs. Small amounts of each sorbent were challenged with single siloxane compounds, a

mixture of the two siloxane compounds, and the siloxanes mixed with volatile organic compounds (VOCs) found in the ISS cabin atmosphere. Gas phase siloxanes and VOC concentrations were generated using a Kintek gas generator fitted with a humidifier. The sorbents (60-75 mg) were crushed and held in a 4-mm diameter sorbent tube. Small discs (20-25 mg) of the activated carbon cloths were used in the sorbent tubes. The gas lines and the sorbent tube were controlled at 23 °C using an automated heating system. Pre- and post-sorbent gas concentrations were measured automatically by a gas chromatograph fitted with a scanning valve. The analytical methods used to measure siloxane removal by sorption are described elsewhere.⁹ The primary factor in this assessment was adsorptive capacity for siloxanes in humid air (40% RH) at a constant air temperature (23 °C).

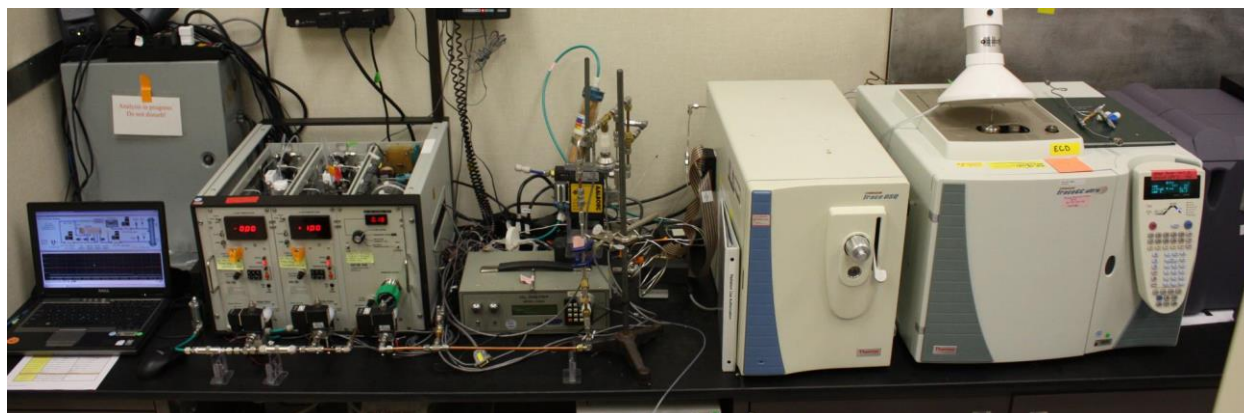

Figure 8. Test rig for evaluating candidate sorbent media.

Table 5. Sorbent candidates for evaluation.

Sorbent	Manufacturer	Type
Super Adsorbent Silica Gel SSA 12001	ADCOA	Silica gel
Zeolite 13X	Sigma Aldrich	Molecular sieve
PpTek	PpTek	Regenerable resin
Ambersorb 4652	DOW	Resin
Cabot Norit GCA 48	Cabot	Activated Carbon
Chemsorb 1000	Molecular Products	Activated Carbon
Cabot Darco BGH	Cabot	Activated Carbon
Cabot Norit RB 40M	Cabot	Activated Carbon
ACC 507 20	American Kynol	Activated Carbon Cloth
Zorflex ACC FM10 Woven	Zorflex	Activated Carbon Cloth
Zorflex ACC FM50 Knitted	Zorflex	Activated Carbon Cloth

After a thorough review of viable candidates, the eleven media listed in Table 5 were evaluated to represent various types of adsorbent media. These media were evaluated in the test rig initially with L2. The data in Fig. 9 were used to reduce the list of candidates to Cabot Norit GCA 48, ACC 507 20, Ambersorb 4652, Chemsorb 1000 and PpTek for further testing with a D3/L2 mixture. Zeolite 13X and ADCOA Silica Gel 12001 were found to be poor candidates for L2 removal under humid conditions. Additional tests identified that L2 could be displaced by D3 via rollover and the data were used to rank the sorbents based on adsorptive capacity. The top 3 candidates (Ambersorb 4652, ACC 50720 and Cabot Norit GCA 48) were selected for testing with an ISS ersatz mixture as defined in Table 6. This testing scheme was designed to shorten the time for down selecting the most promising sorbent candidates for future filter development.

The testing procedure identified that the adsorptive capacities measured with the single siloxane compounds were higher than when a mixture of siloxanes is used, and these capacities were further modified by the presence of other VOCs in the ersatz mixture. In particular, rollover of L2 was observed, that is, the L2 was initially adsorbed and when enough D3 had been adsorbed onto the sorbent, then L2 was being pushed off and C/C_0 was greater than 1 as shown by Fig. 10. The adsorptive capacities for D3 and L2 in the presence of the ISS ersatz for the top three candidates are listed in Table 7.

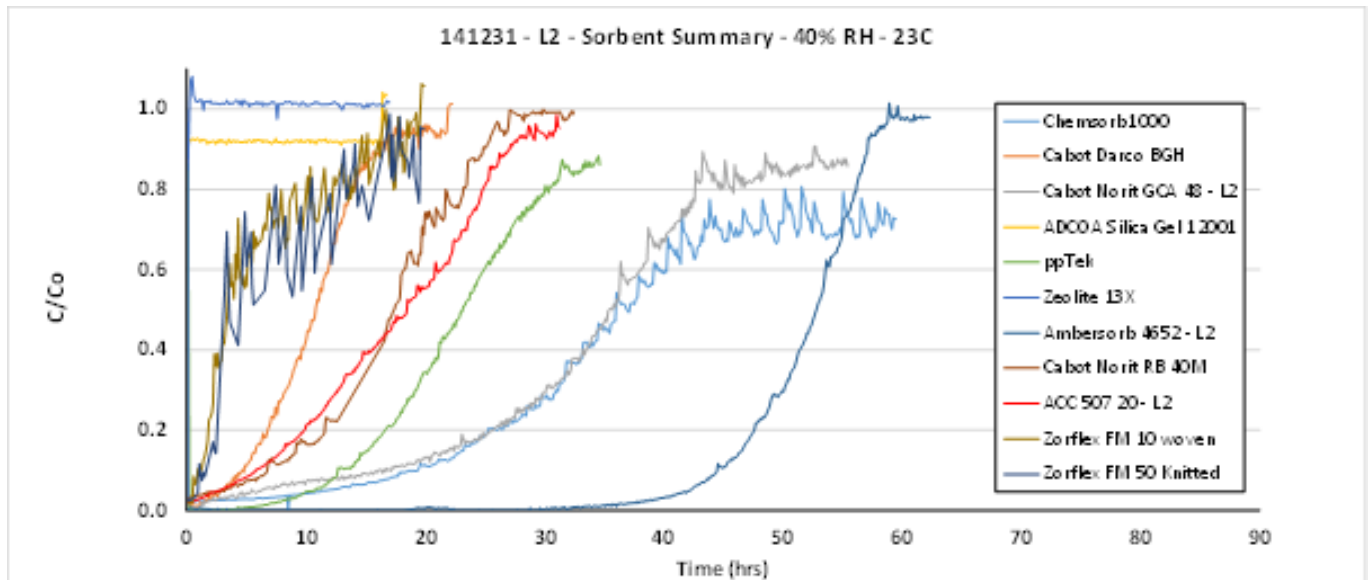

Figure 9. Breakthrough curves for L2 at ISS humidity and temperature. The concentration of L2 breaking through the sorbent tube (C/C_0) is expressed as a fraction of the initial L2 concentration ($C_0 = 4$ ppm)

Table 6. Composition and concentrations of VOCs and siloxanes used in the ISS ersatz mixture.

Volatile Organic Compound	ISS Concentration (ppm)	ISS Ersatz Concentration (ppm)
Acetone	1.9	1.8
Acetaldehyde	0.6	1.0
Ethanol	7.3	3.7
Methanol	3.5	2.5
Propanal	0.3	2.0
Isopropyl Alcohol	2.7	0.7
Toluene	0.4	1.0
p-Xylene	6.9	2.4
L2	-	4.7
D3	0.2	4.5
Trimethylsilanol	2.4	0.7

Table 7. Adsorptive capacity of down selected sorbents.

Sorbent Media	Challenge mixture	D3 Capacity (mg/g)	L2 Capacity (mg/g)
Cabot Norit GCA 48	D3 & L2 Mixture	232	110
Cabot Norit GCA 48	ISS Ersatz Mixture	221	64
Ambersorb 4652	ISS Ersatz Mixture	749	10
ACC 507 20	ISS Ersatz Mixture	809	109

The adsorptive capacity of Cabot Norit GCA 48 for D3 was similar 323 mg/g versus 221 mg/g when the ersatz mixture was used (Fig. 10, purple curve versus blue curve), but the L2 capacity was reduced by 58% due to rollover (Fig. 10, red curve versus dark blue curve). Table 7 shows that the ACC 507 20 activated carbon cloth and the Ambersorb 4652 resin had similar sorptive capacities compared to Cabot Norit GCA 48 based on mg/g capacities. However, the activated carbon cloth has a low density and the resin has very small particle size compared to the large particles of the Cabot Norit GCA 48 activated carbon (4×8 mesh). The impact of these differences on filter design were addressed when scaling the sorption results obtained in the adsorbent media test rig. A further consideration is that the measured sorbent capacities listed in Table 7 will be 40% lower because the concentration of siloxanes in the ISS cabin atmosphere is lower than was used during the testing.

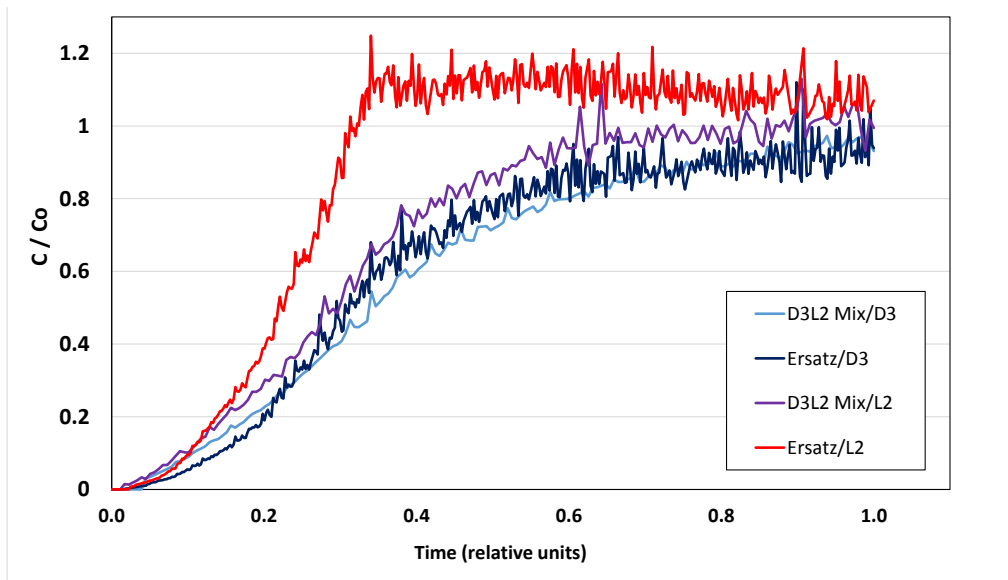

Figure 10. Breakthrough curves of L2 and D3 in Cabot Norit GCA 48. *The effect of the additional VOCs in the ISS ersatz mixture caused rollover of L2 (i.e. $C/C_o > 1$) and reduced adsorbent media capacity for L2.*

V. Concept Development

An initial trade study evaluating the various design factors was performed by Boeing personnel to identify the most viable design concept for siloxane removal. Factors considered in the trade study included design cost, crew time required for maintenance, resupply mass, and siloxane removal performance. The primary concepts considered included the following:

- 1) Adding a siloxane scrubber to the inlet of each ISS Bacteria Filter Elements (BFE). This approach would require a unique design solution for each location and complicate crew training for maintenance.
- 2) Adding a standalone siloxane scrubber separate from the ISS BFEs. This approach is desirable to achieve an overall reduction in atmospheric siloxanes but does not provide direct protection for individual CCAA CHXs. In addition, there is limited volume available on ISS for additional ECLS systems, and limited acoustics margin to accommodate an additional fan.
- 3) Installing siloxane scrubbers only in the four Node 1 BFE locations. This approach is desirable to achieve an overall reduction in atmospheric siloxanes but does not provide direct protection for individual CCAA CHXs.
- 4) Replacing the existing ISS BFE filters with a combination filter media and siloxane scrubber. This approach addresses the desire to provide individual protection for each CCAA CHX but also requires a significant resupply mass to replace the 21 BFEs currently on ISS.

The ground rules and assumptions for the trade study included effective removal of siloxanes, a duration of filter installed lifetime of at least 12 months, and minimal impacts to on-orbit crew operations. A weighted rating system was used to evaluate the options against performance, project, crew time, and logistics. Factors for performance included effective removal of siloxanes, ISS coverage area, time between media change out, reliability, and channeling, sealing, and potential for flow bypass. Factors for the hardware development project included technical risk, schedule risk, recurring costs, and non-recurring costs. Crew time factors included an assessment of initial installation and recurring maintenance. Logistics and re-supply considerations included installation locations, on-orbit stowage volume, launch vehicle limitations, launch weight, and return/refurbishment versus single use.

This trade study ultimately determined that the preferred solution is to replace the current BFEs aboard ISS (qty 21) with a modified filter that incorporates both filtration media (to meet ISS particulate requirement) and an adsorbent media, Ambersorb 4652, for siloxane removal. Ambersorb 4652 was selected because it provided superior siloxane adsorption capacity relative to the other media. However, once the design concept began formulation, it was determined that the pressure drop associated with Ambersorb 4652 was not viable for this location. The pressure drop associated with Ambersorb 4652 would require a significant increase in fan speed, which would violate module-level ISS acoustics requirements that are already at their limits. Therefore, the design concept was modified to use Cabot Norit GCA 48 granular activated carbon instead, which provided measurably more siloxane capacity for the same pressure drop compared to Ambersorb 4652, as shown in Fig. 11.

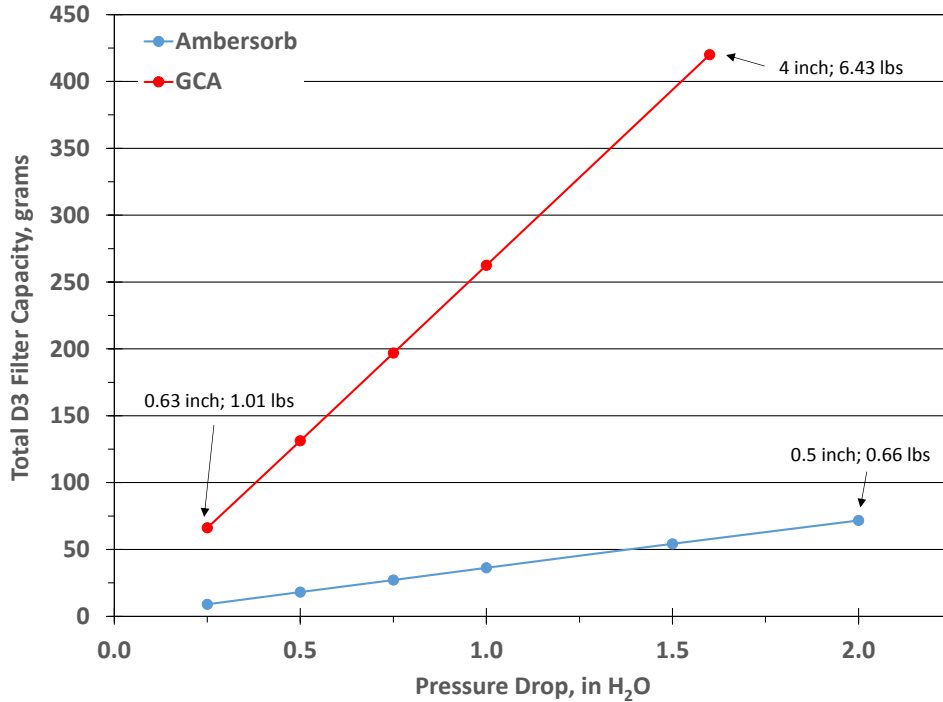

Figure 11. Estimated total filter capacity for D3 siloxane as a function of allowable pressure drop estimated by Ergun equation at 50 CFM flow. Displayed are filter depths and estimated media weight for select data points. Ambersorb bulk density 0.37 g/mL; sieved to mean particle size of 531 μm . GCA bulk density 0.45 g/mL; mean screen size of 3.57 mm. Partial pressure adjusted (Poylani potential energy adjusted) media D3 capacities taken to be 288 mg/g (Ambersorb) and 144 mg/g (GCA). Filter cross sectional area taken to be 0.0638 m².

VI. Implementation Aboard the ISS

During this design effort, the loss of Orbital Sciences Corporation's third cargo vehicle (Orb-3) resulted in losing critical hardware enroute to ISS for the ISS WPA. This lost hardware included two Multifiltration Bed assemblies that were expected to be needed to replace expired beds in 2015. As stated previously, DMSD is saturating both Multifiltration Beds, ultimately requiring replacement of both beds once DMSD reaches the product water and drives the TOC above 3 mg/L. With the loss of this hardware on Orb 3, ground personnel began an accelerated effort to manufacture and deliver two new Multifiltration Bed assemblies to the ISS before the expected need date in 2015.

In parallel, the engineering team also recommended delivery of charcoal filters to remove siloxanes suitable for installing in place of the BFEs in Node 1. This rapid delivery and implementation was considered possible because ten Cabin Air Catalyst Element Assembly (CACEA) units used during early ISS assembly between 1998 (four in Node 1) and 2001 (six in the U.S. Lab) to scrub the atmosphere of the new module prior to crew ingress were returned to KSC after use and placed in storage in case a situation arose where they might be needed. As the filters were now needed, four of the CACEA units were disassembled, cleaned, and re-packed with fresh Cabot Norit charcoal using spare felt filter bags from ISS stores. Although this implementation does not directly protect the CHX units aboard ISS since there are no CHX units in Node 1, the four modified filters installed in Node 1 are predicted to reduce the siloxane concentration in the ISS cabin atmosphere by up to 75%. This reduction is anticipated to reduce the concentration of DMSD in the condensate and therefore extend the life of the current Multifiltration Beds on ISS. Charcoal filter installation occurred in May 2015. As the team completes conceptual design of the final implementation, the performance of these temporary charcoal filters in Node 1 will be watched carefully via atmosphere sample data from the Air Quality Monitor and waste water grab samples returned to earth.

VII. Conclusion

Engineering personnel have completed the initial effort toward the development of a scrubber for removal of siloxanes from the ISS atmosphere. Bench tests at MSFC and UTAS have determined that the only viable path toward insuring a credible reduction in the DMSD concentration in the condensate is with near complete removal of the atmospheric PDMS compounds. Tests at KSC have identified the adsorbents most appropriate for this application, though limited pressure drop in this application precludes the use of the highest performance adsorbent. Instead, the Cabot Norit GCA 48 was selected based on siloxane capacity per unit pressure drop. Based on this research, ground tests are currently underway at UTAS to define the optimum design concept, after which the flight hardware will be manufactured and delivered to ISS. Implementation on ISS is expected to be achieved in late 2016.

Acknowledgments

The authors thank the test engineers, chemists, and technicians at KSC, MSFC, Boeing, and UTAS for their contributions to this effort.

References

- ¹Xu, S. Fate of Cyclic Methylsiloxanes in Soils. 1. The Degradation Pathway. *Environ. Sci. Technol.* 1999, 33, 603-608.
- ²Xu, S., Chandra, G. Fate of Cyclic Methylsiloxanes in Soils. 2. Rates of Degradation and Volatilization. *Environ. Sci. Technol.* 1999, 33, 4024 – 4039.
- ³Rector, T., Metselaar, C., Peyton, B., Steele, J., Michalek, W., Bowman, E., Wilson, M., Gazda, D., and L. Carter. ICES Paper No. 135, “An Evaluation of Technology to Remove Problematic Organic Compounds from the International Space Station Potable Water,” *44th International Conference on Environmental Systems*, Tucson, Arizona, July, 2014.
- ⁴Macatangay, A.V., Perry, J.L., Belcher, P.L., and Johnson, S.A., “Status of the ISS Trace Contaminant Control System,” SAE 2009-01-2353. *SAE 39th International Conference on Environmental Systems*. Savannah, Georgia; July 2009.
- ⁵Schweigkofler, M., Niessner, R., *Removal of Siloxanes from Biogas*, Journal of Hazardous Materials, B83, 2001, 183-196.
- ⁶Schwartz, W., Laliberte, Y., *Heat Exchanger ORU SV813900-2 S/N 001, Test, Teardown and Evaluation Final Report*, August 12, 2009, Page 2 of the Executive Summary.
- ⁷Buch, R. R.; Ingebrigtsen, D. N., “Rearrangement of poly(dimethylsiloxane) fluids in soil,” *Environ. Sci. Technol.* 1979, 13, 676 – 679.
- ⁸Perry, J.L., Elements of Spacecraft Cabin Air Quality Control Design, NASA TP-1998-207978, May 1998, pp. 60, 145-148.
- ⁹Richards, J., Koss, L., and O. Monje., “An Automated Test-Bed for Rapid Characterization of Sorbent Materials for Siloxane Removal in Contaminated Airstreams,” ICES-2015-298, *45th International Conference on Environmental Systems*, Bellevue, Washington, July 2015.