

Elastomer Seal Performance after Terrestrial Ultraviolet Radiation Exposure

Christopher C. Daniels¹, Heather A. Oravec², and Janice L. Mather³
The University of Akron, Akron, OH 44325-3901

Shawn C. Taylor⁴
The University of Toledo, Toledo, OH 43606

Patrick H. Dunlap⁵
NASA Glenn Research Center, Cleveland, OH 44135

Ultraviolet radiation was evaluated to determine its negative effects on the performance of elastomeric gas pressure seals. The leak rates of the silicone elastomer S0383-70 O-ring test articles were used to quantify the degradation of the seals after exposure to vacuum-ultraviolet and/or middle-to-near-ultraviolet wavelength radiation. Three groups of seals were exposed in terrestrial facilities to 115-165 nm wavelength radiation, 230-500 nm wavelength radiation, or both spectrums, for an orbital spaceflight equivalent of 125 hours. The leak rates of the silicone elastomer S0383-70 seals were quantified and compared to samples that received no radiation. Each lot contained six samples and statistical t-tests were used to determine the separate and combined influences of exposure to the two wavelength ranges. A comparison of the mean leak rates of samples exposed to 115-165 nm wavelength radiation to the control specimens showed no difference, suggesting that spectrum was not damaging. The 230-500 nm wavelength appeared to be damaging, as the mean leak rates of the specimens exposed to that range of wavelengths, and those exposed to the combined 115-165 nm and 230-500 nm spectrums, were significantly different from the leak rates of the control specimens. Most importantly, the test articles exposed to both wavelength spectrums exhibited mean leak rates two orders of magnitude larger than any other exposed specimens, which suggested that both wavelength spectrums are important when simulating the orbital environment.

Nomenclature

a_0	=	zero-order regression coefficient
a_1	=	first-order regression coefficient
β	=	bias error
i, k	=	indices
m	=	mass
\dot{m}	=	mass leak rate
N	=	number of samples
p	=	absolute pressure
ϕ	=	precision error
R	=	specific gas constant
T	=	temperature
t	=	time

¹ Associate Research Professor, Department of Mechanical Engineering, AIAA Senior Member.

² Research Assistant Professor, College of Engineering, AIAA Member.

³ Senior Research Engineer, College of Engineering.

⁴ Senior Research Associate, Mech., Ind. and Manufacturing Engineering, AIAA Senior Member.

⁵ Research Mechanical Engineer, Materials and Structures Division, 21000 Brookpark Rd. MS 23-3.

U = uncertainty
 V = volume

I. Introduction

Since the beginning of the manned space program, elastomeric gas pressure seals have been used to confine breathing air inside space vehicles.¹ Elastomeric seals have been used in part for their performance at temperatures,²⁻⁹ reusability,¹⁰ ability to distort with their substructure,¹¹ and low leak rate.^{2-4,7-8} As the United States plans to embark on missions with longer durations,¹² the challenges of utilizing elastomer compound seals become more evident. Destinations such as low-Earth orbit, asteroids, and the lunar and Martian surfaces are harsh environments for materials to survive and require materials to withstand atomic oxygen,¹³⁻¹⁷ ultraviolet and particle radiation,^{13-15,18} micrometeoroids and orbital debris,^{14,18-21} and dust,^{18,22-23} amongst others.

The elastomers currently used on docking ports are silicone¹¹ and are susceptible to degradation from ultraviolet radiation (UV) as they are exposed and unprotected during the mission.¹⁰ Incident UV fragments the silicone elastomer macromolecules causing surface cracking.²⁴ The shortened molecules cross-link, recombining with one another causing loss of elasticity and the formation of a brittle layer on the elastomer's surface, leading to further surface cracking.

Amongst many seal characteristics, including forces required to compress and separate, outgassing, operating and survivable temperature range, the seal's leak rate performance²⁵⁻²⁶ is integral to the success of any manned mission. Under ideal circumstances, the leakage of elastomer gas pressure seals is dominated by permeation of gas through the body of the seal, and flow through the interface between the seal and its counter face is negligible.²⁷ Unfortunately, degradation of the elastomer from UV (and other environmental sources) damages the surface of the seal and serves to increase the interface leakage while the permeation of the seal remains constant.

UV is electromagnetic radiation with wavelengths longer than X-rays and shorter than visible light. This radiation spectrum can be subdivided into vacuum-UV, middle-UV, and near-UV.²⁸ The term vacuum-UV refers to electromagnetic radiation with wavelengths shorter than 200 nm. Middle- and near-UV is electromagnetic radiation with wavelengths from 200 to 300 nm, and 300 to 400 nm, respectively. Wavelengths in the visible spectrum range from 380 to 760 nm. Wavelengths in the UV spectrum are emitted from the Sun in different quantities and have different energy levels, and therefore penetrate and affect materials differently based upon the chemical bonds within the elastomer's microstructure.²⁴

The amount of incident UV an exposed spacecraft component receives during a mission is dependent upon the mission duration, spacecraft orientation, and orbit. Since the computations are complex and vary with time, predictions of UV exposure are typically calculated using proprietary computer models for all but the simplest orbits. Rough estimates of UV exposure for low-Earth orbits may be computed using orbital mechanics and a standard reference of solar intensity.²⁸

The leak rate performance of the gas pressure seals dictates the quantity and weight of resources required of the environmental control and life support system that supplies the astronauts' breathing air. Reduced seal performance results in additional resources that must be brought on a mission, thereby increasing a vehicle's launch weight and cost. Because of the seal's importance, extensive characterization of the leak rate is required during the spacecraft's design phase. To minimize the cost of a seal's developmental program, environmental factors may be screened such that only significant contributors are included in the testing.

In this study, different radiation ranges in the UV spectrum were evaluated for their contributions to the degradation of elastomeric seal leak rate performance. The objective was to determine the separate and combined influences of different wavelengths on the leak rate of S0383-70 silicone elastomer O-ring seals. By understanding their contribution, the influence of each wavelength range can be weighed against the cost and schedule expense for inclusion or deletion from the overall test program.

II. Experimental Setup

A. Test articles

The test articles evaluated in this study were standard AS568A size 2-309 O-ring gas pressure seals manufactured from S0383-70 silicone elastomer compound by Parker Hannifin Corporation. Their nominal dimensions are shown in Table 1. The median measurement of Shore M durometer was 68.1.

Table 1. Nominal dimensions of the test specimens.

Inner diameter, in. (mm)	Thickness, in. (mm)
0.412 ±0.005 (10.5 ±0.127)	0.210 ±0.005 (5.33 ±0.127)

The silicone material contained minimal amounts of low weight molecules that are released when exposed to a vacuum environment (i.e., S0383-70 is a low outgassing material). This desirable characteristic minimizes the amount of material that would potentially deposit on spacecraft optics, solar panels, and instruments and was achieved during the post-cure cycle of manufacture. Random samples were verified to be low outgassing per ASTM E595-07,²⁹ as defined by having a total mass loss (*TML*) less than 1% and a collectible volatile condensable material (*CVCM*) less than 0.1%, as shown in Table 2.

Table 2. Outgassing values.

Silicone elastomer compound	<i>TML</i> (%)	<i>CVCM</i> (%)
S0383-70	0.11	0.01

Prior to the onset of the study, the test specimens were cleaned with an isopropyl alcohol soaked lint free cloth and permitted to dry.

B. UV exposures

Select test articles were exposed to UV in a terrestrial *Enhanced UV Test Facility* at Marshall Space Flight Center³⁰ using mercury-xenon lamps. One type of exposure consisted of 230 to 500 nm wavelength radiation across the middle- and near-UV ranges, referred to herein as NUV, at approximately 1.0 equivalent sun intensity (where 1.0 represents the rate equivalent to natural on-orbit exposure oriented perpendicular to the sun; a value higher than 1.0 represents a faster than natural on-orbit exposure). Another exposure consisted of 115 to 165 nm wavelength radiation in the vacuum-UV range at approximately 2.9 equivalent suns intensity and was referred to as VUV.

A total of 24 test articles were utilized in this study. The specimens were divided into four lots of equal numbers. One lot was exposed to NUV and another to VUV. A third lot was exposed to both NUV and VUV sequentially, while the fourth lot was the control group and received no exposure. The six specimens exposed to both components of UV were exposed to NUV first, then VUV. After exposure, the specimens were stored such that the exposed sealing surfaces did not come in contact with other surfaces and were not subjected to UV sources other than room lighting.

All of the cumulative dosages of UV-exposure were reported in units of equivalent sun hours (ESH). An ESH is the amount of energy within a defined spectral range incident on a surface oriented perpendicular to the sun at an intensity of one solar constant for one hour duration. This allows for comparisons between developmental testing and flight scenarios where light sources do not have equivalent spectrums or intensities, and surface orientations to the light source are not similar or constant.

C. Leak rate tests

The leak rate of each test article was quantified using a mass point leak rate method with a constant pressure differential and custom test apparatus.³¹ The apparatus was comprised of two flat platens manufactured from stainless steel, each with a surface roughness better than 0.4 μm. The test article was installed into a standard O-ring groove in the bottom platen, Fig. 1. The platens were assembled such that each test article was compressed by 25% of its nominal height. The platens were aligned using three pins and held together using three sets of nuts and bolts.

The test gas used was dry air and was supplied to the test article's interior from the high-pressure side of the apparatus at approximately 124 kPa. A control system reduced the pressure on the outside of the seal until the pressure differential across the seal was 101 kPa. The control system maintained a constant value of differential pressure across the seal such that as the high internal pressure was reduced by leakage, the control system lowered the low pressure by a similar amount. The result was a constant leak rate throughout the duration of each experiment.

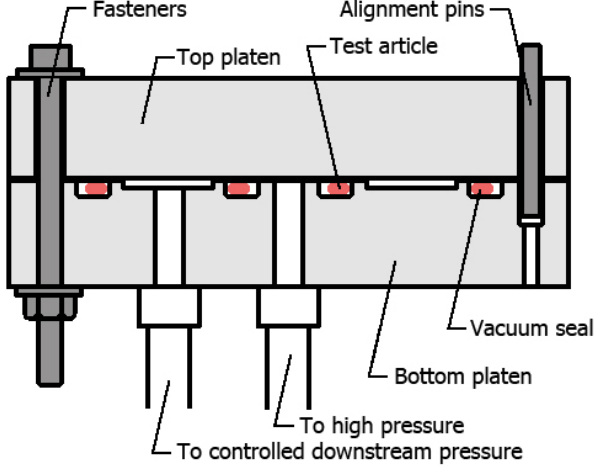

Figure 1. Diagram of the test section cross-section.

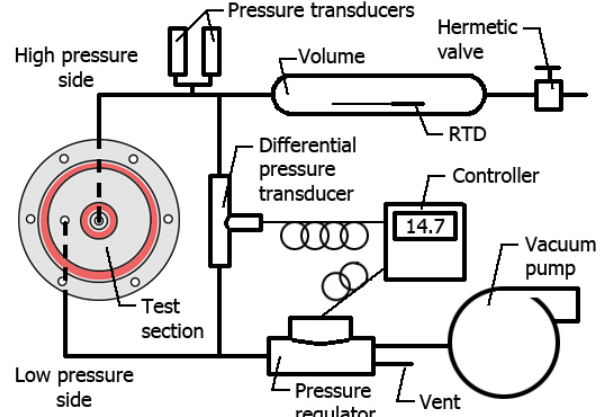

Figure 2. Diagram of the test fixture.

The high internal gas pressure was monitored using two pressure transducers, see Fig. 2. The average of the two readings at each time step was used in the computations. The temperature was monitored using a Class A accuracy resistance temperature detector (RTD) attached to the external surface of the volume. The volume of the high-pressure side was determined using an average of 248 applications of *Boyle's Law* (i.e., $p_1V_1 = p_2V_2$). The size of the volume was approximately 70.59 ml for each of the three test apparatuses used to collect the data.

The mass loss calculations were computed by the data acquisition and control system using gas properties on the high-pressure side of the test apparatus. Using a technique described in Ref. 31, the mass of gas within the high-pressure side of the apparatus was calculated at every time step using the pressure and temperature data and Eqn. 1.

$$m = \frac{pV}{RT} \quad (1)$$

At each time step, a linear least-squares regression through the mass-time data set resulted in a first-order function of the test article's leak rate behavior with time, Eqn. 2. The first-order coefficient represented the specimen's leak rate.

$$m(t) = a_1t + a_0 \quad (2)$$

The measurement uncertainty of the leak rate was computed in real-time using Eqns. 3 and 4. The bias and precision errors used in Eqn. 4 were unique to each of the three test apparatuses used during the study, and were obtained using instrument calibration records (e.g., pressure transducers), product specifications (e.g., RTD), or computations (e.g., the volume). Representative error values are presented in Tables 3 and 4 for the reader's understanding.

$$U_m^2 = \sum_{i=1}^N \left(\frac{\partial \dot{m}}{\partial m_i} \right)^2 \beta_{m_i}^2 + \sum_{i=1}^N \left(\frac{\partial \dot{m}}{\partial m_i} \right)^2 \phi_{m_i}^2 \quad (3)$$

where,

$$\begin{aligned} \beta_m^2 &= \left(\frac{V}{RT} \beta_p \right)^2 + \left(\frac{p}{RT} \beta_V \right)^2 + \left(\frac{pV}{T} \beta_R \right)^2 + \left(\frac{pV}{R} \beta_T \right)^2 \\ \phi_m^2 &= \left(\frac{V}{RT} \phi_p \right)^2 + \left(\frac{p}{RT} \phi_V \right)^2 + \left(\frac{pV}{T} \phi_R \right)^2 + \left(\frac{pV}{R} \phi_T \right)^2 \end{aligned} \quad (4)$$

and

$$\frac{\partial \dot{m}}{\partial m_i} = \frac{Nt_i - \sum_{i=1}^N t_i}{N \sum_{i=1}^N (t_i^2) - (\sum_{i=1}^N (t_i))^2}$$

To minimize differences between the temperature measurements and the actual gas temperature, the test section, pressure transducers, volume, RTD, and hermetic valve were contained within an environmental control chamber set to a temperature of 23°C.

Table 3. Representative bias error values.

<i>Bias error</i>	<i>Variable</i>	<i>Value</i>
Pressure	β_p	1.05E-4 kPa
Volume	β_V	2.131 cm-cm-cm
Specific gas constant	β_R	0
Temperature	β_T	0.196 °C

Table 4. Representative precision error values.

<i>Precision error</i>	<i>Variable</i>	<i>Value</i>
Pressure	ϕ_p	1.93E-2 kPa
Volume	ϕ_V	0.392 cm-cm-cm
Specific gas constant	ϕ_R	0
Temperature	ϕ_T	2.14E-2 °C

Statistical evaluations were conducted on the data to conclusively show similarities and differences would withstand criticism. Confidence levels of 95%, standard in the engineering field, were used for all statistical calculations.

III. Results and Discussion

A. Exposures

The NUV exposure was conducted on 12 specimens, followed by the VUV exposure on 12 specimens with six specimens receiving both NUV and VUV exposures. The select test articles that were exposed to NUV received a dose of 125.4 ESH; VUV samples received a total dose of 125.0 ESH. The temperatures of the specimens were monitored during the exposures and did not exceed 38 and 23°C during NUV and VUV exposures, respectively.

The test articles were oriented nearly perpendicular to the UV emitting light source such that the major axis of the O-ring pointed towards the lamp. The specimens were not reoriented, rotated, or moved during the UV exposures. As such, only the top half of the O-ring received any exposure; the bottom half was shaded by the top half and did not receive UV. Because of the circular cross-sectional geometry of the O-ring, the level of UV exposure (125 ESH) was received only by the crest of the top surface. The portion of the surface at the horizon, where the lamp lit surface met the shaded portion of the surface, received 0 ESH of UV, see Fig. 3. The dosage of UV for any point on the lit portion of the top surface could be closely estimated using,

$$\begin{aligned} \text{UV [ESH]} &= 125 \cos(\alpha); \text{ for } \alpha \in (-\pi/2, \pi/2) \\ &= 0; \text{ for } \alpha \notin (-\pi/2, \pi/2) \end{aligned} \quad (5)$$

B. Leak rate tests

The data acquisition system collected the pressure and temperature data at an average rate of 10 samples per channel per second. The leak rate and associated measurement uncertainty were calculated in real-time throughout the experiment. The test concluded when the measurement uncertainty was at or below 10%.

The assumptions of the statistical evaluations used in the study required that the data sets be normally distributed. Therefore, the Anderson-Darling test³² for normality was applied to each resultant data set. The p-values

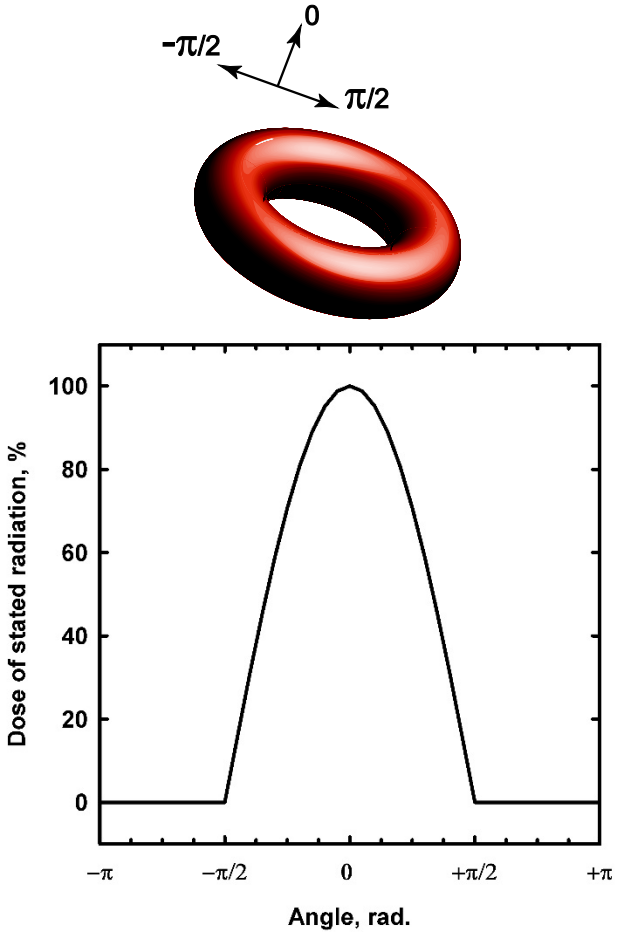

Figure 3. View factor of the toroid-shaped O-ring to the ultraviolet lamp.

for each data set were sufficiently large ($p > \alpha = 0.05$) to conclude that each data set was independently normally distributed and no further transformations were necessary.

Prior to exposure, the specimens to be UV exposed were tested to determine their as-manufactured leak rate in order to disclose any intrinsic defects. Each of the 24 specimens was tested in random order and resulted in a mean leak rate of 2.89×10^{-12} kg/s. A Grubb's test³² for outliers was computed, but indicated that there existed no outlying data and no reason to discard any test specimens from the study.

After UV exposure, the specimens were tested in random order and their results statistically analyzed. Visually reviewing the data, one point in the NUV data (referred to as N+49-03) was much higher than others in the same group. A Grubb's test for outliers was applied. If all values were truly from the same, normally distributed population, then the Grubb's test computed the probability of 0.0% of obtaining a leak rate value as large as that of N+49-03. As this probability was less than 5%, N+49-03 was deemed a statistical outlier and removed from the study.

The leak rate values resulting from each test article, including the outlier, are graphically shown in Fig. 4. The mean leak rate values are shown in Table 5.

Table 5. Mean leak rate results.

<i>Exposure</i>	<i>Mean leak rate (Pre-exposure), $\times 10^{-12}$ kg/s</i>	<i>Mean leak rate (Post-exposure), $\times 10^{-12}$ kg/s</i>
None (control group)	3.27	n/a
125 ESH of NUV	3.31	5.75 ¹
125 ESH of VUV	2.58	3.41
125 ESH of NUV and 125 ESH of VUV	2.79	257.

1. Leak rates compared to the control group

Two-sample t-tests were applied to each UV exposed data set to determine if the mean leak rates of the groups were different than the as-manufactured control data set. If deemed to be statistically different, the result would indicate that the particular UV exposure had degraded the seal performance.

There was sufficient evidence indicating that the means of the control and NUV data sets were different. The resultant p-value of the comparison was 0.001; meaning that stating there was a difference between the means had a 0.1% chance of being incorrect. The exposure of 125 ESH of terrestrial NUV was sufficient to degrade the leak rate performance of a standard 2-309 S0383-70 material O-ring.

There was no evidence to support the claim that the means of the control and VUV data sets were different. A statement that there was a difference between the means had a 24.6% probability of being incorrect. Since 24.6% exceeded 5%, the claim had to be rejected to meet the 95% confidence level specified. In practical terms, 125 ESH of terrestrial VUV exposure did not appear to degrade the seal's leak rate performance.

There was sufficient evidence to support the claim that the means of the control and NUV+VUV data sets were different. Stating that there was a difference between the means had a 0.0% probability of being incorrect. Simply stated, the exposure of 125 ESH of

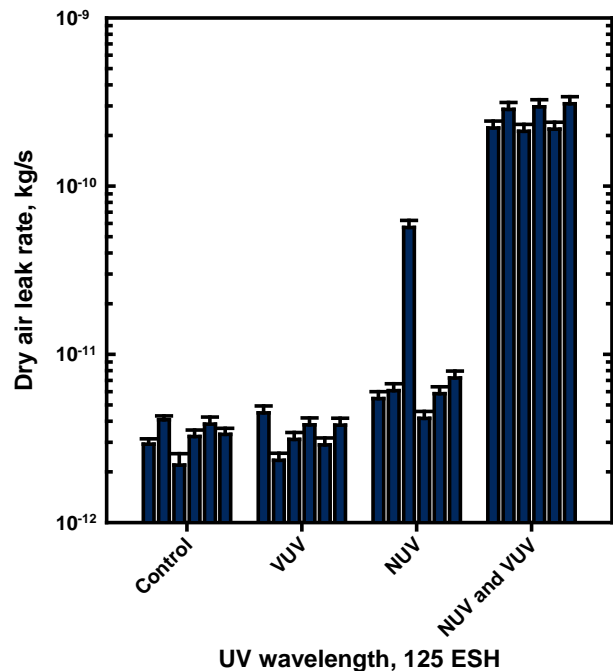

Figure 4. Leak rate results of replicate samples after exposure to UV. Error bars represent measurement uncertainty.

¹ Mean value with outlier removed from the data set; including the outlier would result in a mean of 1.43×10^{-11} kg/s.

terrestrial NUV followed by 125 ESH of terrestrial VUV exposure was sufficient to degrade the leak rate performance.

2. Differences between leak rates of UV exposed specimens

Two-sample t-tests were applied between UV exposed data sets to determine if the mean leak rates of the groups were different. If deemed to be statistically different, the result would indicate that one particular UV exposure had degraded the seal performance greater than the other.

There was sufficient evidence indicating that the NUV and the VUV mean leak rates (5.75×10^{-12} and 3.41×10^{-12} kg/s, respectively) were different. Stating that there was a difference had a 0.3% chance of being incorrect. As the mean leak rate of the NUV data set was larger than the mean leak rate of the VUV data set, the 125 ESH of NUV was deemed more damaging to the S0383-70 elastomer compound.

Not surprisingly, there was sufficient evidence to support the claim that the means of the NUV and the NUV+VUV data sets were different. Stating that there was a difference had a 0.0% probability of being incorrect. As the mean leak rate of the NUV+VUV data set was two orders of magnitude larger than the mean leak rate of the NUV data set, the combined exposure of 125 ESH of NUV followed by 125 ESH of VUV was deemed more damaging to the S0383-70 elastomer compound than exposure to 125 ESH of NUV alone.

C. Visual observations

During leak rate testing, specimens were seated in a standard O-ring groove and were compressed against a flat counter-face surface, as in Fig. 1. No lubrication was used on the test hardware or O-ring surfaces. Following individual tests on the NUV and combined NUV and VUV exposed O-rings, an oil-like liquid in an annular shape, matching the footprint of the compressed O-ring, was observed on the hardware counter-face. Each specimen left a residue, see Fig. 5(a), that was very thin and marked the location where the O-ring was in contact with the counter-face surface. Also observable were marks indicating where the top platen came in repeated contact with the bottom platen during the test sequence, see Figs. 5(a) and 5(b). The hardware was cleaned with isopropyl alcohol between all leak tests, regardless of the observance of residue, such that no cross-contamination was possible.

The leak rate tests conducted on the control and VUV exposed test articles did not appear to leave a residue on the test hardware. This information suggests that the silicone compound's molecular chains were scissored into small mobile fragments during exposure to NUV and were transferred to the test fixtures. The absence of residue after the VUV tests could also indicate that the exposure to VUV was either not significantly damaging to the compound or that it penetrated and damaged the compound too deeply to allow for the fragments to migrate to the free surface upon compression.

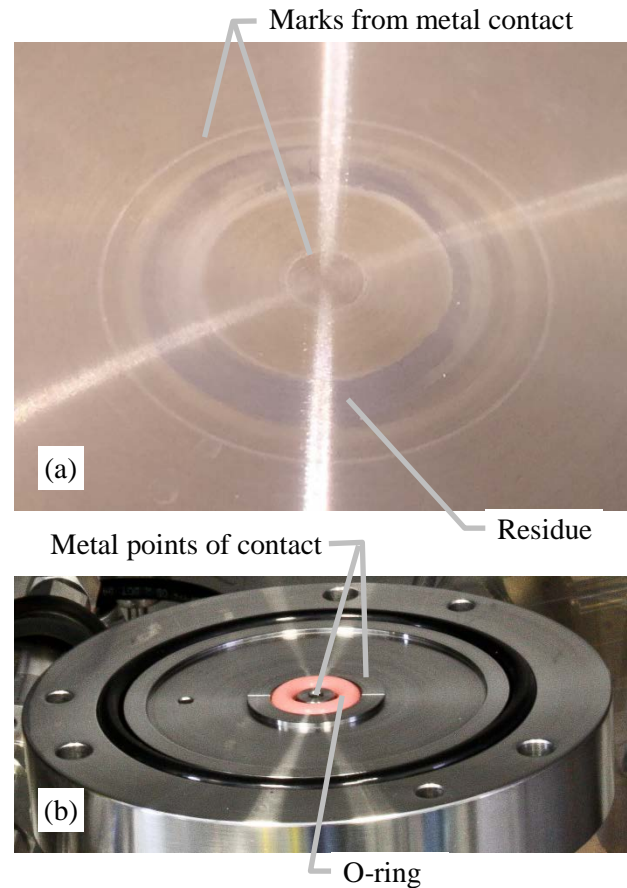

Figure 5. Photograph of the test fixture showing (a) the top platen on which residue was observed only after tests conducted on specimens exposed to NUV, and (b) the bottom platen indicating points of metal-to-metal contact with top platen and an O-ring test article.

IV. Conclusions

Four lots of 2-309 size O-rings manufactured from S0383-70 silicone elastomer compound were exposed to different terrestrial-based ultraviolet radiation exposures, including 125 ESH of NUV, 125 ESH VUV, both 125 ESH NUV followed by 125 ESH VUV, or no exposure. The specimens were subsequently leak rate tested using dry

air as the test gas. The mass point leak rate method with a constant differential pressure of 101 kPa was used to quantify the leak rate, and each test had a duration long enough to obtain a measurement uncertainty of 10% or better. Statistical analyses were computed on the data sets and resulted in several conclusions. VUV exposure of 125 ESH did not degrade the test articles sufficiently to differentiate the mean leak rate from the leak rate of unexposed control specimens. Test articles exposed to NUV at a level of 125 ESH and those exposed to 125 ESH of both NUV and VUV resulted in leak rates that were uniquely different from the VUV and control data sets. While the VUV exposure alone, at 125 ESH, did not appear to degrade the leak rate performance of the O-rings, the combination of VUV with 125 ESH prior NUV exposure resulted in the greatest damage. The O-rings exposed to both NUV and VUV had far larger leak rates (two orders of magnitude) than any other exposure. The leak test results suggest that any developmental test program seeking to conservatively ascertain the degradation of seal materials by UV exposure include radiation in both the NUV and VUV wavelength ranges.

Acknowledgements

The authors wish to acknowledge the contributions of NASA Marshall Space Flight Center for exposing the test articles to ultraviolet radiation. Support for this work was provided by the National Aeronautics and Space Administration under contracts NNC08CA35C and NNC13BA10B.

References

- ¹Charhut, D.E., Byke, R.M., and McClelland, C.M., "Design of Space Stations for Low Atmospheric Leakage." *Journal of Spacecraft and Rockets*, 9(1), January, 1972, pp. 26-32.
- ²Garafolo, N.G., and Daniels, C.C., "Experimental Investigation of Leak-Rate Performance of a Subscale Composite Elastomer-Retainer Docking Seal." *Journal of Spacecraft and Rockets*, 50(3), May-June 2013, pp. 709-714.
- ³Smith, I. M., Daniels, C. C., Dunlap, P. H., and Steinetz, B. M. "Performance of Sub-scale Docking Seals under Simulated Temperature Conditions," AIAA Paper 2008-4713, 2008.
- ⁴Wasowski, J.L., Penney, N., Garafolo, N.G., and Daniels, C.C., "Leak Rates of a Candidate Main Interface Seal at Selected Temperatures," AIAA Paper 2009-5320, 2009.
- ⁵Hartzler, B.D., Panickar, M.B., Wasowski, J.L., and Daniels, C.C., "Comparison of Adhesion and Retention Forces for Two Candidate Docking Seal Elastomers," AIAA Paper 2011-2158, 2011.
- ⁶Bastrzyk, M.B., and Daniels, C.C., "The Mechanical Performance of Subscale Candidate Elastomer Docking Seals," AIAA Paper 2010-3129, 2010.
- ⁷Bastrzyk, M.B., Garafolo, N.G., and Daniels, C.C., "Compression Force Response and Leak Rate Quantification of Candidate Static Silicone Space Seals," AIAA Paper 2010-6908, 2010.
- ⁸Garafolo, N.G., Bastrzyk, M.B., and Daniels, C.C., "The Effects of Atomic Oxygen on the Sealing and Mechanical Performance of an Elastomer Seal," AIAA Paper 2010-1440, 2010.
- ⁹Conrad, M.C., Daniels, C.C., Hartzler, B.D., and Panickar, M.B., "Retention Failure Forces in Candidate Space Docking Seals," AIAA Paper 2011-5639, 2011.
- ¹⁰Fehse, W., *Automated Rendezvous and Docking of Spacecraft*, Cambridge: Cambridge University Press, 2003.
- ¹¹Illi, E., "Space Station Freedom Common Berthing Mechanism," *Proceedings of the 26th Aerospace Mechanism Symposium*, NASA CP 3147, Washington, DC, 1992, pp. 281-296.
- ¹²National Aeronautics and Space Administration, *NASA's Exploration System Architecture Study – Final Report*, NASA TM-2005-214062, 2005.
- ¹³Linton, R.C., Finckenor, M.M., Kamenetzky, R.R., and Gray, P., "Effects of Atomic Oxygen and Ultraviolet Radiation on Candidate Elastomeric Materials for Long-Duration Missions. Test Series No. 1," NASA-TM-108408, 1993.
- ¹⁴Ferguson, D.C., "Lunar Natural Environment for Use by the Constellation Program," AIAA Paper 2009-754, 2009.
- ¹⁵Daniels, C.C., Wasowski, J.L., Panickar, M.B., and Smith, I.M., "Leak Rate Performance of Three Silicone Elastomer Compounds after Ground-Simulated and On-Orbit Environmental Exposures," AIAA 2011-3823, 2011.
- ¹⁶Penney, N., Wasowski, J.L., and Daniels, C.C., "Temperature and Atomic Oxygen Effects on Helium Leak Rates of a Candidate Main Interface Seal," AIAA Paper 2010-6986, 2010.
- ¹⁷Christensen, J.R., Underwood, S.D., Kamenetzky, R.R., and Vaughn, J.A., "Atomic Oxygen Effects on Seal Leakage," *Proceedings of the 20th Space Simulation Conference: The Changing Testing Paradigm*, NASA/CP 1999-208598, National Aeronautics and Space Administration, Washington, DC, 1999, pp. 195-206.
- ¹⁸Barth, J.L., "Space and Atmospheric Environments: from Low Earth Orbits to Deep Space," Ed. J. Kleiman, Ed. Z. Iskenderova. *Protection of Materials and Structures from Space Environment*. Netherlands: Springer, 2003: 7-29.
- ¹⁹de Groh III, H.C., and Steinetz, B.M., "Effects of Hypervelocity Impacts on Silicone Elastomer Seals and Mating Aluminum Surfaces," AIAA Paper 2009-5249, 2009.
- ²⁰de Groh III, H.C., Gallo, C.A., and Nahra, H.K., "Meteoroid and Orbital Debris Threats to NASA's Docking Seals: Initial Assessment and Methodology," AIAA Paper 2009-3524, 2009.
- ²¹Larson, W.J., and Pranke, L.K., *Human Spacecraft: Mission Analysis and Design*, 1st ed. New York: McGraw Hill, Feb 1999.

- ²² Garafolo, N.G., and Daniels, C.C., "Contamination Simulation of Elastomer Space Seals with Foreign Object Debris," AIAA Paper 2011-3674, 2011.
- ²³ Gaier, J.R., "The Effects of Lunar Dust on EVA Systems during the Apollo Missions," NASA/TM 2005-213610, 2005.
- ²⁴ Dever, J.A., "Low Earth Orbital Atomic Oxygen and Ultraviolet Radiation Effects on Polymers," NASA TM-103711, 1991
- ²⁵ Dunlap, P.H., Daniels, C.C., Steinetz, B.M., Erker, A.H., Robbie, M.G., Wasowski, J.L., Drlik, G.J., Tong, M.T., and Penney, N., "Full-Scale System for Quantifying Leakage of Docking System Seals for Space Application," AIAA Paper 2007-5742, 2007.
- ²⁶ Dunlap, P.H., Daniels, C.C., Wasowski, J.L., Garafolo, N.G., Penney, N., and Steinetz, B.M., "Pressure Decay Testing Methodology for Quantifying Leak Rates of Full-Scale Docking System Seals," AIAA Paper 2009-5319, 2009.
- ²⁷ Garafolo, N.G., and Daniels, C.C., "An Empirical Investigation on Seal-Interface Leakage of an Elastomer Face Seal," *Proceedings of the ASME 2012 Fluids Engineering Summer Meeting*, 8-12 Jul 2012, Rio Grande, Puerto Rico FEDSM2012-72026, 2012.
- ²⁸ International Organization for Standardization, "Space Environment (Natural and Artificial) - Process for Determining Solar Irradiances," ISO 21348:2007(E), Switzerland, p. 5.
- ²⁹ ASTM International, "ASTM E595-07 (Reapproved 2003): Standard Test Method for Total Mass Loss and Collected Volatile Condensable Materials from Outgassing in a Vacuum Environment," 2003.
- ³⁰ National Aeronautics and Space Administration, "Marshall Space Flight Center Solar and Ultraviolet Radiation Testing," FL-2013-11-138-MSFC, https://partnerships.msfc.nasa.gov/sites/default/files/G-33798_SURT_0.pdf [cited 22 Jan 2015].
- ³¹ Daniels, C.C., Braun, M.J., Oravec, H.A., Mather, J.L., and Taylor, S.C., "Leak Rate Quantification Method for Gas Pressure Seals with Controlled Pressure Differential," *Proceedings of the 51st AIAA/ASME/SAE/ASEE Joint Propulsion Conference*, AIAA, Washington, DC (to be published).
- ³² NIST/SEMATECH *e-Handbook of Statistical Methods*, <http://www.itl.nist.gov/div898/handbook/> [cited 20 Jan 2015].