

Near-Infrared Volatile Spectrometer System (NIRVSS) Spectrometers for NASA's Resource Prospector (RP) Mission

Readiness level:
 TRL 1-3: Concept
 TRL 4-6: Prototype
 TRL 7-9: Demonstrated

NASA Ames Instrumentation Workshop

September 16, 2015

Technology / Application

- Modified COTS, MEMS-based with 2 fiber fed optical engines
- Acquires spectra between 1600-3400 nm, <15 nm resolution
- Identify key volatiles (solid and gas) and minerals while surface roving and sub-surface drilling

Mass (g)	2197 w/ fibers, heaters, thermostat
Size (mm)	≈ 200 x 170 x 85
Power (W)	idle / nominal / peak 6.8 / 6.8 / 7.36

References: Ennico et al 2013, NASA Lunar Sci. Inst. Poster, Roush et al. 2014, Am. Geo. Union poster, Roush et al. 2015, Lunar Planet. Sci. Conf. abstract #1956, Roush et al. NLSI Exp. Sci. Forum; 2015, Roush et al. 2015 RP Workshop 1; Roush et al. 2016, AIAA SciTech control ID #2315946

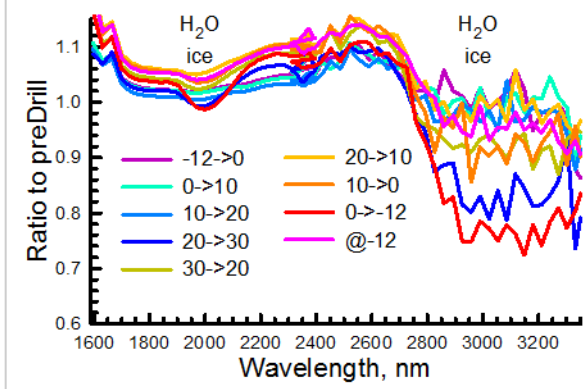
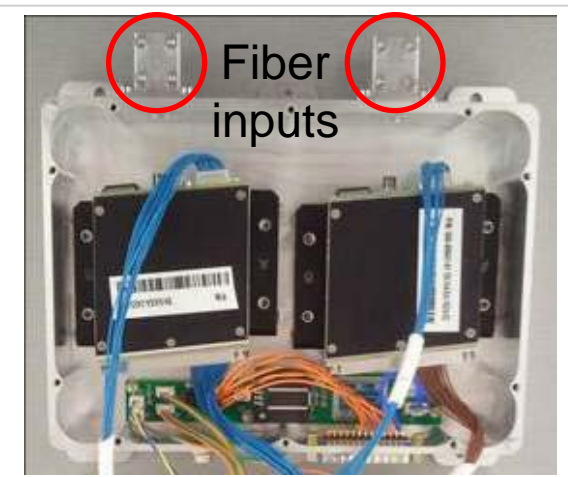

Funding / Timeline

- **2011** Idea conception , **2012** SOW to vendor w/ support from HEOMD
- **2013** EDU delivered, tested in cryovac tests @ Glenn Research Center (GRC)
- **2014** EDU → ETU development, field testing in Mojave
- **2015** ETU tests in cryovac @GRC and on rover @ Johnson Space Center
- **Future** – Modifications to ETU, field testing, and deployment on RP

POC

POC: Ted Roush/Tony Colaprete, Code SST
 • **Email:** ted.l.roush@nasa.gov
 • **Phone:** 650-604-3526