



# Increment 45/46 Science Symposium Advanced Colloids Experiment (ACE-T1)



Presented by:

**Dr. William V. Meyer (*a.k.a.* Bill Meyer)**  
ACE NASA Project Scientist



USRA at NASA GRC, Tel: (216) 433-5011, Email: [William.V.Meyer@NASA.Gov](mailto:William.V.Meyer@NASA.Gov)  
ACE NASA Project Manager: Ron Sicker, Tel.: (216) 433-6498  
ZIN-Technologies Project Lead: Dan Brown, Tel: (440) 625-2219  
ZIN-Technologies Science Lead: John Eustace, Tel: (440) 625-2244

July 15, 2015

# ACE-T1 science team



**Prof. Chang-Soo Lee**

Department of Chemical Engineering  
Chungnam National University (CNU)  
South Korea



**Group members involved in this project**

- Chang-Hyung Choi
- Jae-Min Jung
- So-Young Han

**Prof. Chang-Soo Lee**

[S. KoreanTeam: CNU]

PI / Provide flight samples,  
science requirements, and data analysis

Professor of Chemical Eng., Department of Chemical Engineering  
School of Engineering, 1-258  
Chungnam National University, Daejeon, Korea  
Tel: 82-42-821-5896; [rhadum@cnu.ac.kr](mailto:rhadum@cnu.ac.kr)

ACE-T1 is a NASA collaboration with Professor Chang-Soo Lee at Chungnam University (CNU), South Korea, resulting from a June 2009 U.S. - Korean summit and report "Joint Vision for the Alliance of the United States of America and the Republic of Korea".

# ISS Increments 45 and 46 Science Symposium

## Advanced Colloids Experiment (Temperature controlled) – **ACE-T1**

- Science Background and Hypothesis
- Investigation goals and objectives
- Measurement approach
- Importance and reason for ISS
- Expected results and how they will advance the field
- Earth benefits/spin-off applications

# Science Background and Hypothesis – 1/2

## Science Background

- Project explores 3D self-assembly of complex (Janus, multi-sided) particles that are hydrophobic and hydrophilic (repel and attract water). Microgravity allows for the observation of 3D assembly of submicron particles that would sediment on Earth. This work is done on ISS with the aid of the the Light Microscopy Module (LMM) to lay the foundations for colloidal engineering (how to build nanobots) using Janus particles.
- ACE-T-1 will study colloidal engineering with an emphasis on self-assembly, which spontaneously forms precisely organized structures by thermodynamic equilibrium. This work has the promise of providing efficient and affordable manufacturing processes for functional devices and materials with novel or enhanced properties. The complex structures that result from self-assembly at the molecular level are regulated by highly specific and directional interactions. In contrast, colloidal building blocks are generally limited complex and highly ordered structures because of their highly symmetric potentials (*e.g.*, electrostatic and van der Waals interactions tend to dominate). The shape anisotropy of colloidal building blocks promises to be a workable alternative that will enable shape-selective interactions with directionality specificity designed for building significant complex structures.

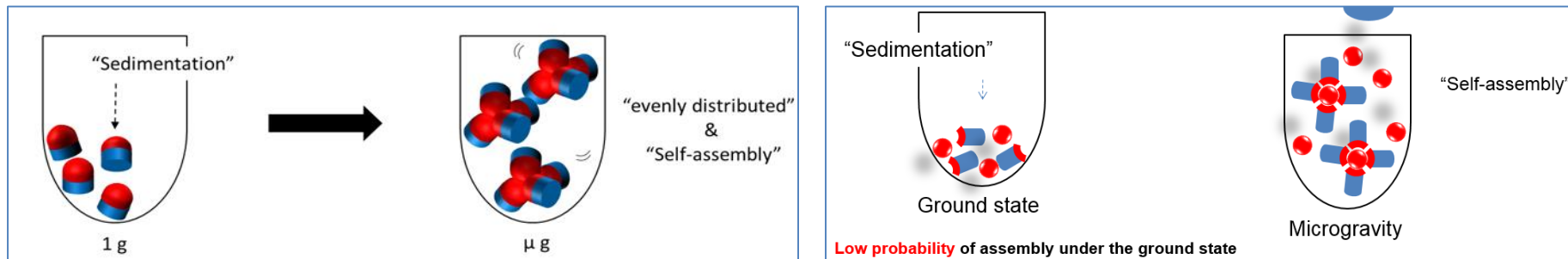

# Hypothesis

Fundamental science and colloidal engineering can be pursued and understood directly at a particle level.

Microscopy enables scientists to directly observe what is happening at a colloid particle level - one no longer requires a theoretical model to hope to connect macroscopic experimental observations to microscopic ones (as when observing experiments at the size scale seen with a photograph taken of a BCAT or PCS sample).



# ACET1 (CNU) investigation goals and objectives

## Microscopic self-assembly

1. Combination of force

2. Shape

3. Topology

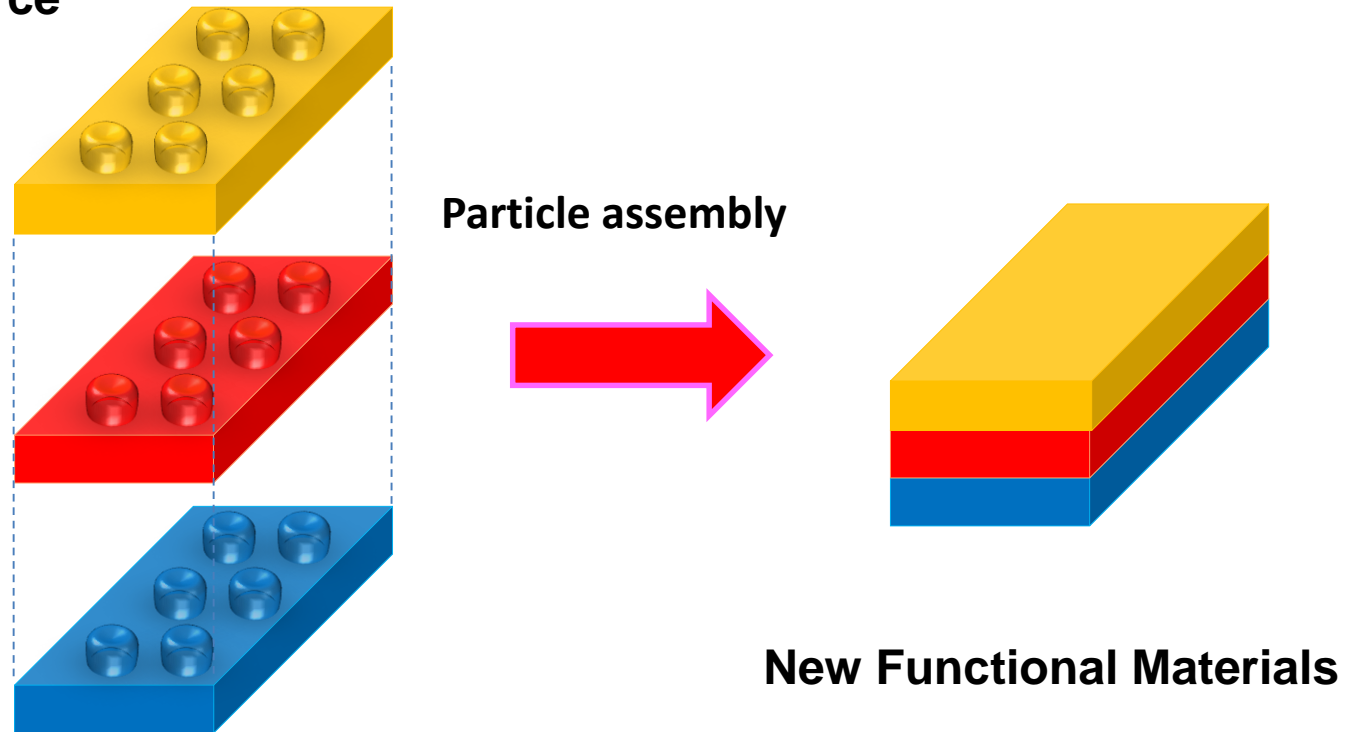

Novel building block  
“atoms” & “molecules” of tomorrow’s materials

Ref.: Science, 306, 2004

Nature materials, 10, 2011

# Microscopic self-assembly

## Plan 1

Anisotropic building blocks  
(Janus amphiphilie)

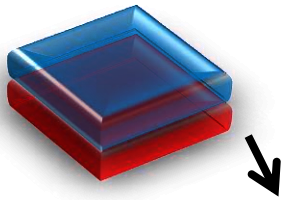
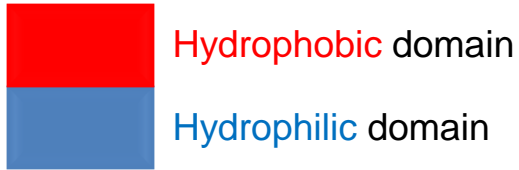

“Sedimentation”

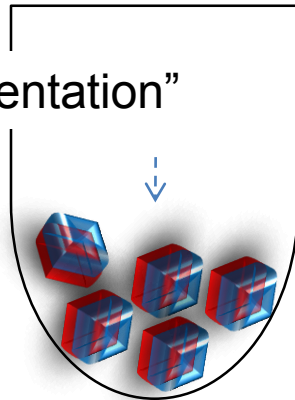

Ground state

Programmed assembly for dimers

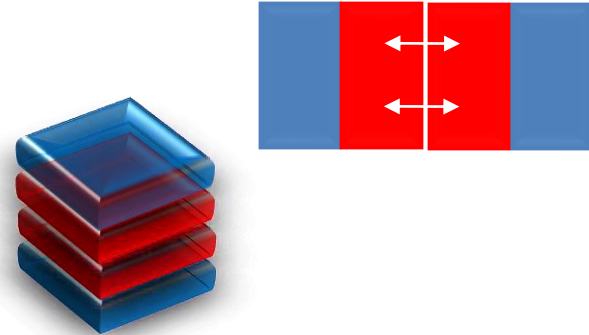

“Self-assembly”

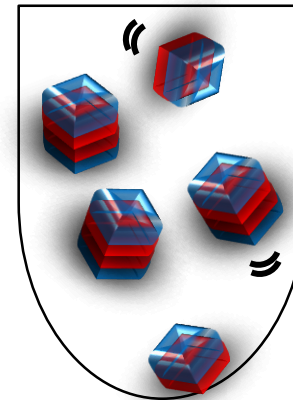

Microgravity

**Low probability** of assembly in the ground state

# Microscopic self-assembly

## Plan 2

Microscale building block  
(Janus lock & Hydrophobic key)

Lock



Key



Programmed assembly for dimers



“Sedimentation”

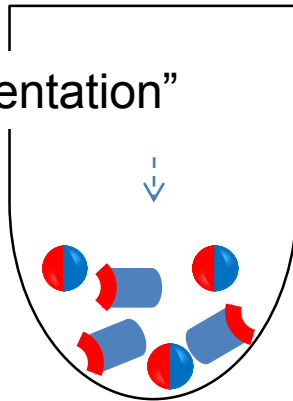

Ground state

“Self-assembly”

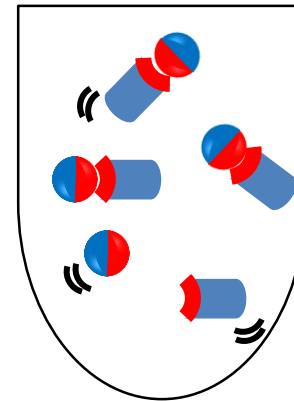

Microgravity

**Low probability** of assembly in the ground state



# Microscopic self-assembly

## Plan 3 (analogy multivalent ligand)

Microscale building block  
(Janus lock & Hydrophobic key)

Lock



Key



“Sedimentation”

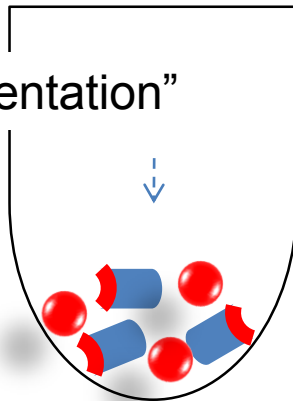

Ground state

**Low probability** of assembly in the ground state

Programmed assembly  
(analogy **Multivalent** ligand)

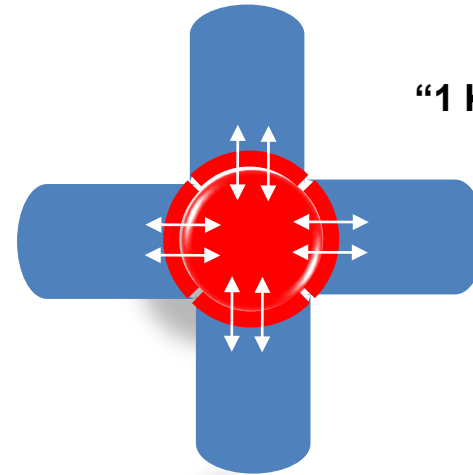

“1 Key + N Locks”

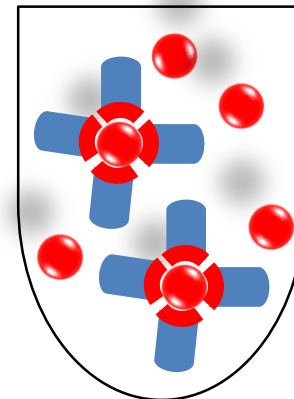

“Self-assembly”

Microgravity

# Measurement approach

We will be using a flight-hardened Commercial-Off-The-Shelf (COTS) microscope

[pictured on next page]

and an

ACE-T sample module

[pictured later]

# Measurement approach – 1/9

## Light Microscopy Module (LMM) in the Fluid Integrated Rack (FIR)

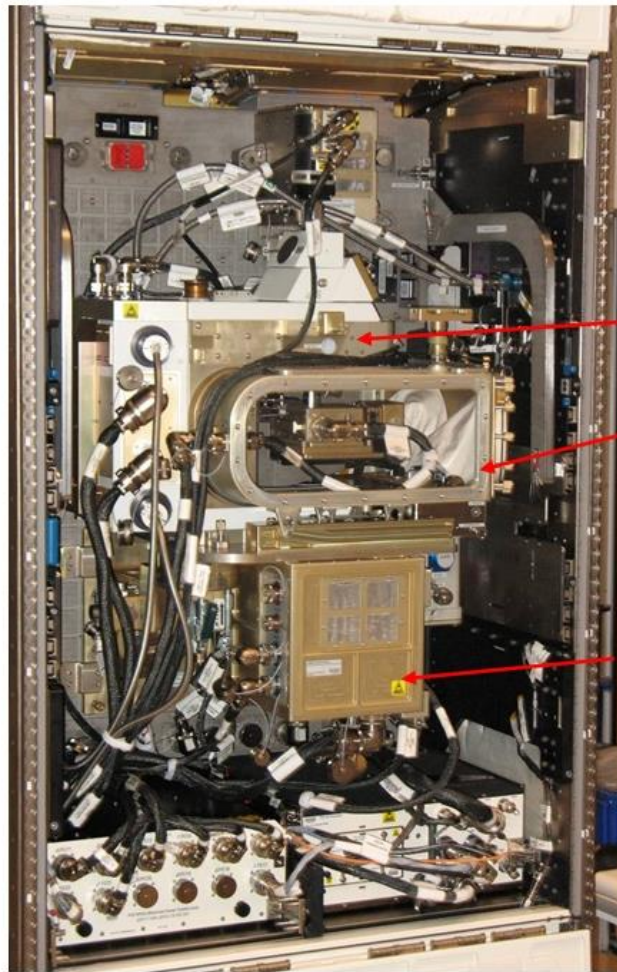

LMM in the Closed Position or Operating Configuration

Monochrome Camera

Microscope

Auxiliary Fluids Container (AFC) – Left Side

LMM Control Box

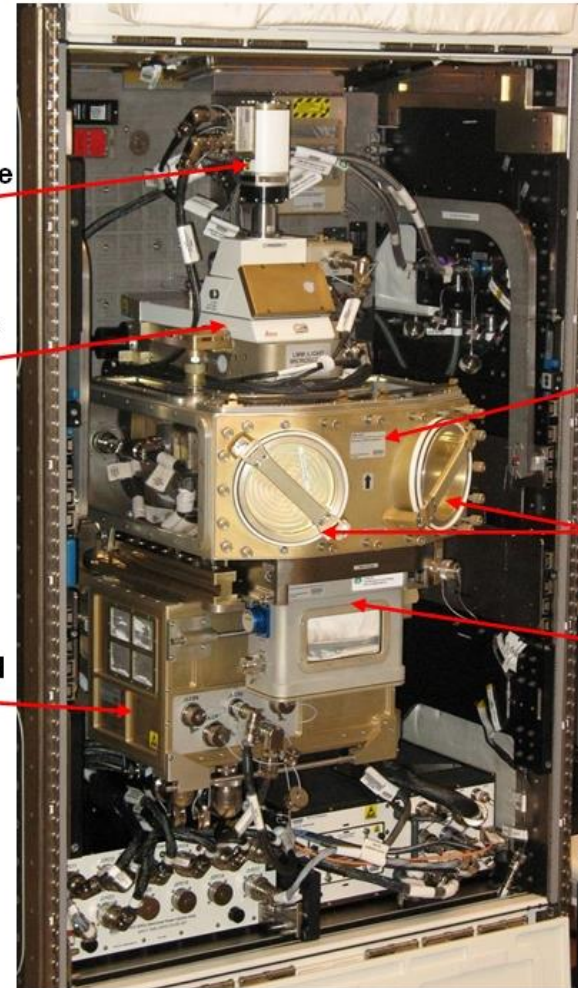

Auxiliary Fluids Container AFC - Front

Glove ports

Equipment Transfer Module (ETM)

LMM in the Open Position or Installation/Service Configuration

# Measurement approach – 2/9

## LMM Implementation Philosophy

Philosophy: Maximize the scientific results by utilizing the existing LMM capabilities. Develop small sample modules and image them within the LMM

Payload specific and multi-user hardware customizes the FIR in a unique laboratory configuration to perform research effectively.

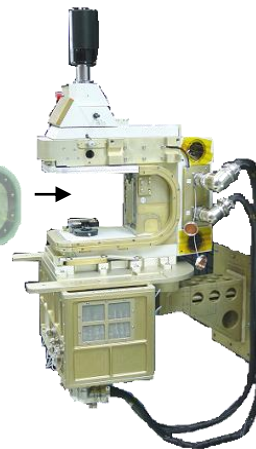

### Payload Specific Hardware

- Sample Cell with universal Sample Tray
- Specific Diagnostics
- Specific Imaging
- Fluid Containment

### Multi-Use Payload Apparatus

- Test Specific Module
- Infrastructure that uniquely meets the needs of PI experiments
- Unique Diagnostics
- Specialized Imaging
- Fluid Containment

### FCF Fluids Integrated Rack

- Power Supply
- Avionics/Control
- Common Illumination
- PI Integration Optics Bench
- Imaging and Frame Capture
- Diagnostics
- Environmental Control
- Data Processing/Storage
- Light Containment
- Active Rack Isolation System (ARIS)

# Measurement approach – 3/9

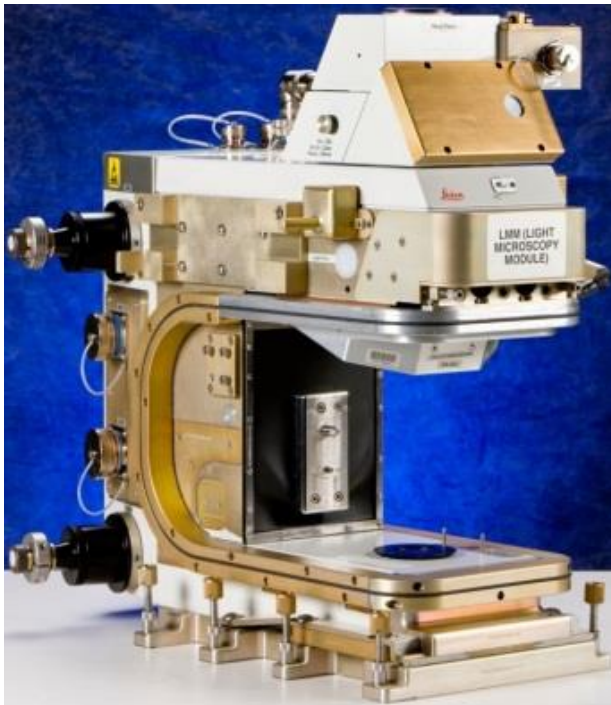

Light Microscopy Module (LMM)

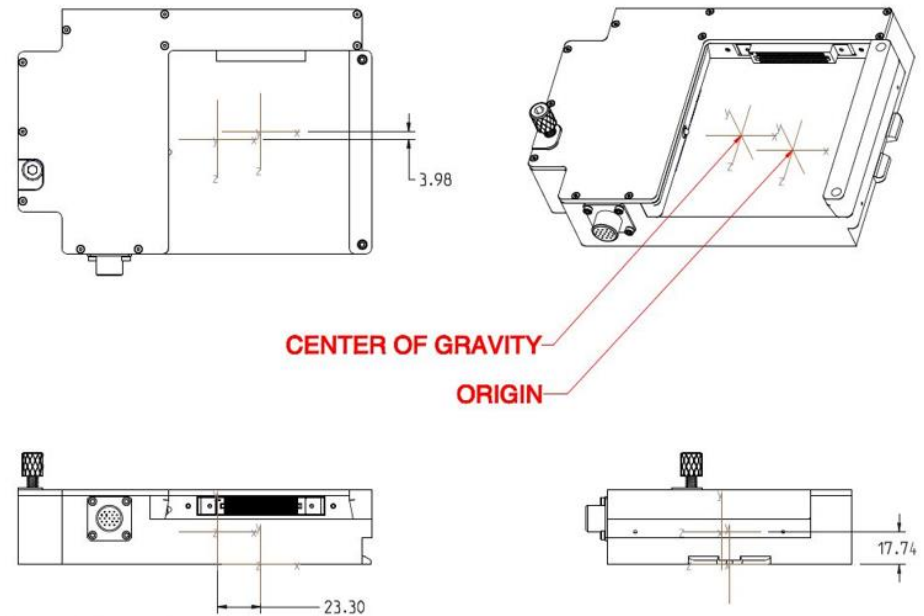

Figure 1: Center of Mass for ACE-T

ACE Sample Assembly with Removable ACE-T Sample Tray that will contain a row of 3 temperature controlled capillary cells



# Measurement approach – 4/9

## Mechanical Design Highlights

- Modular sample assemblies
- Allows for multiple sample configurations.
  - Easier Sample replacement
  - Decreased “ACE-T” up-mass in comparison to ACE-H

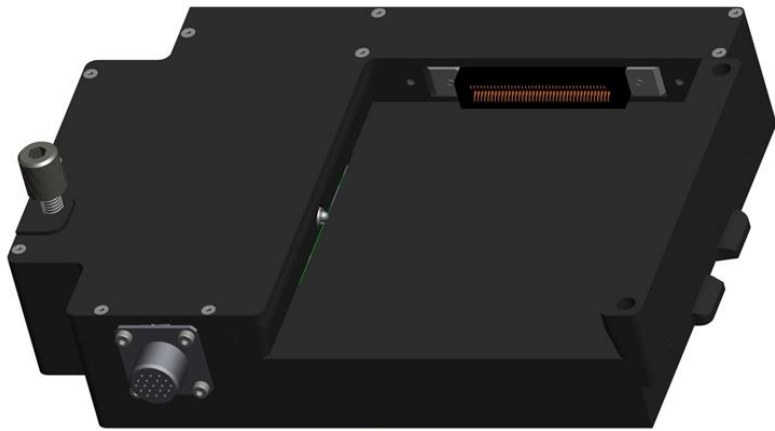



# Measurement approach – 5/9

## Mechanical Design Highlights

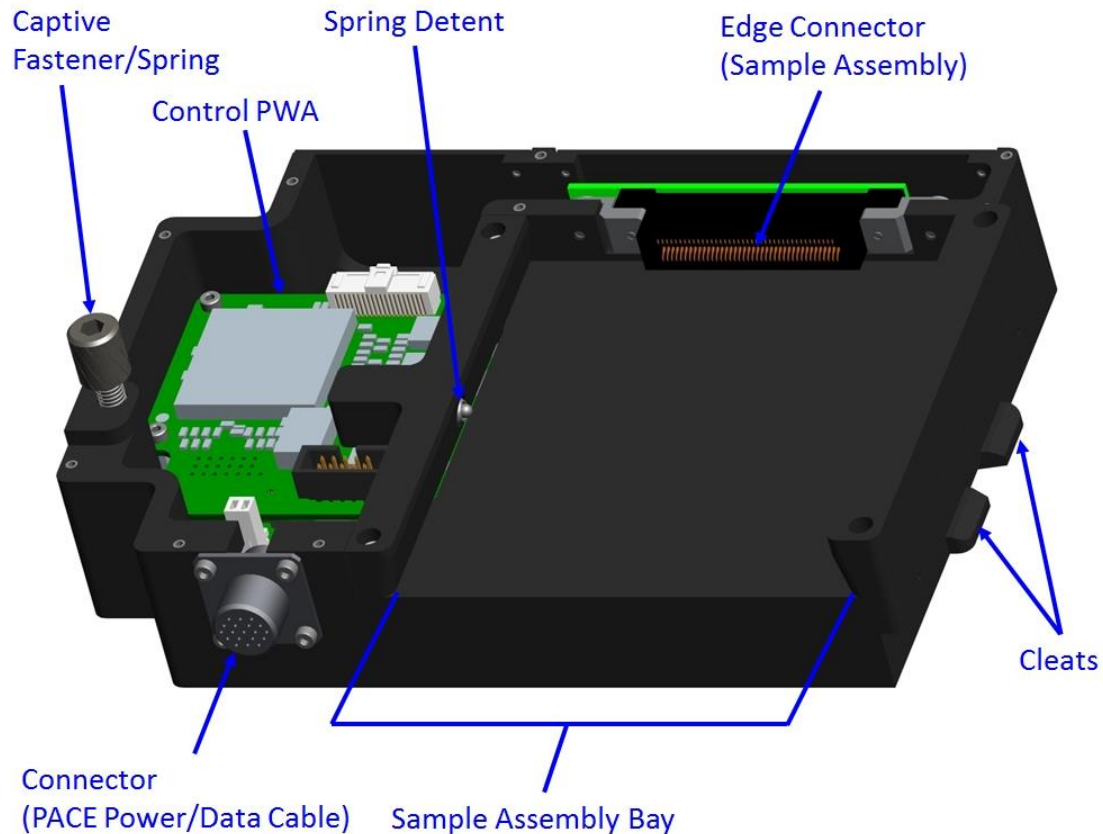

# Measurement approach – 6/9

## Mechanical Design Highlights

- In-situ mixing (details in electrical section)
- Black Hard Anodize Surface Coat
  - Reduction of any errant light within the AFC
  - Increased wear resistance

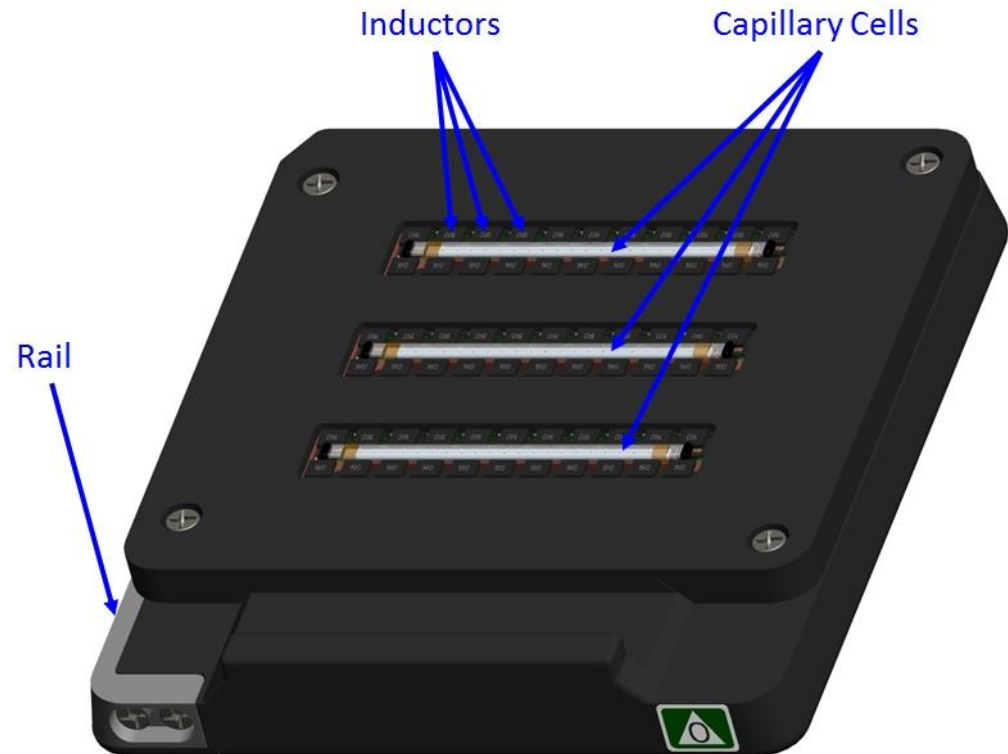

# Measurement approach – 7/9

## Mechanical Design Highlights

### Capillary cell

- Purchased through VitroCom.com
- Material
  - Borosilicate (3520-050)
  - Fused Silica by request (3520S-050)
- COTS
- 50mm length
- Reference Marks
  - Secondary Process to ease positional awareness

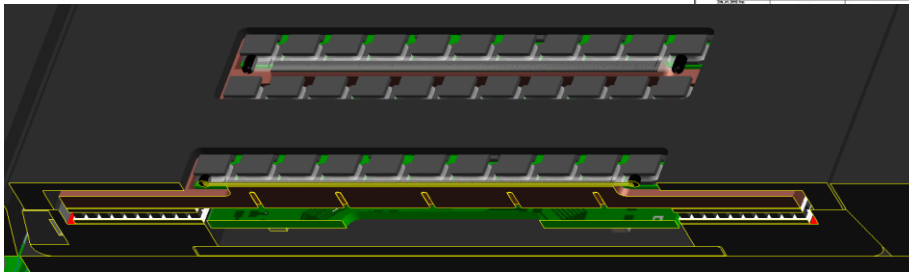
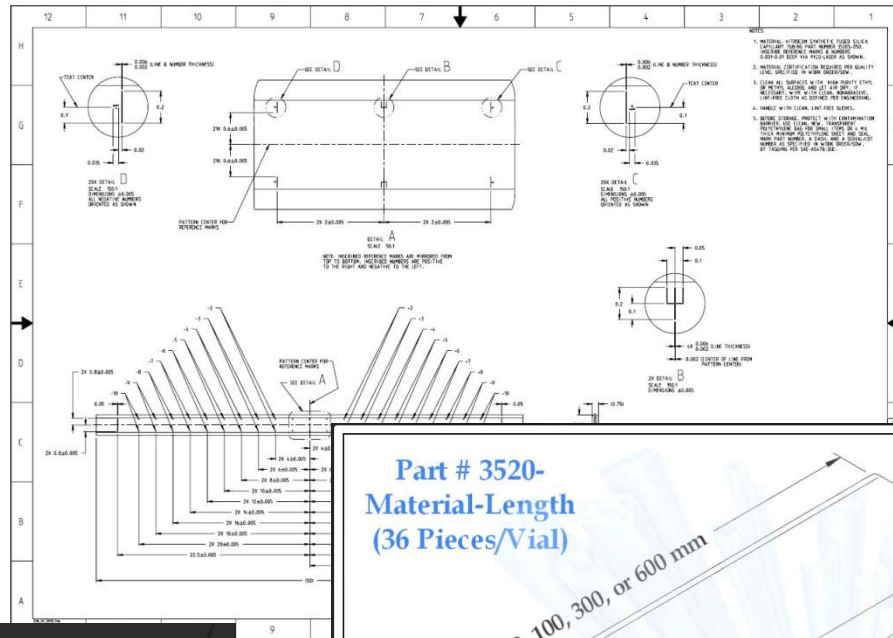

Two capillary cells surrounded by inductors that are used for walking a turning stir-bar for sample mixing.

**Part # 3520-  
Material-Length  
(36 Pieces/Vial)**

TOLERANCES	LENGTH (mm)	
ID +/- 10 %	50 +2 / -0	300 +10 / -0
Wall +/- 20 %	100 +4 / -0	600 +20 / -0

**VITROCOM**  
TECHNICAL GLASS

# Measurement approach – 8/9

## Temperature gradient option

- Thermal bridge
    - Material: Copper
    - Bridges thermal energy between TEM's
    - Constrains Thermistor Positioning
    - Thermal symmetry across X and \*Y Axis
- \*When set-points are equal

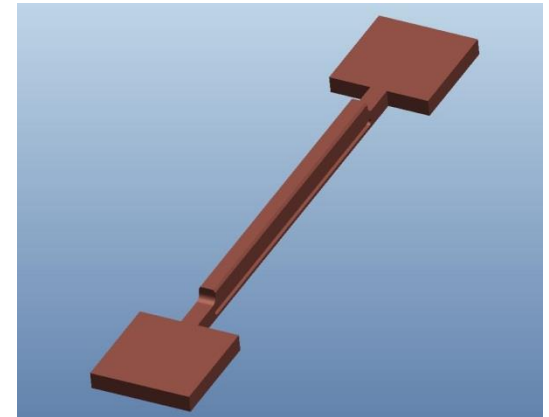
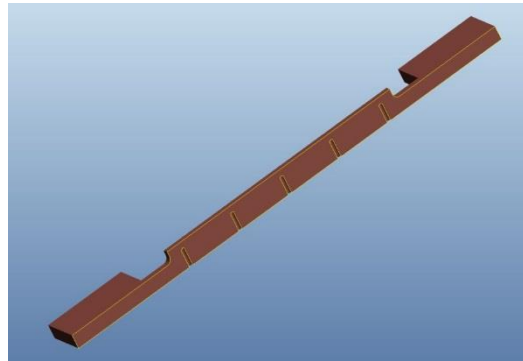

Bonus information: ACE-T, in general, will enable temperature control that can either be linear across the capillary - or a temperature gradient across the capillary. A temperature gradient will form a density gradient! You can now march through a phase diagram using a single capillary and have a common error bar for all measurements.

### Hard Sphere Equilibrium Phase Diagram

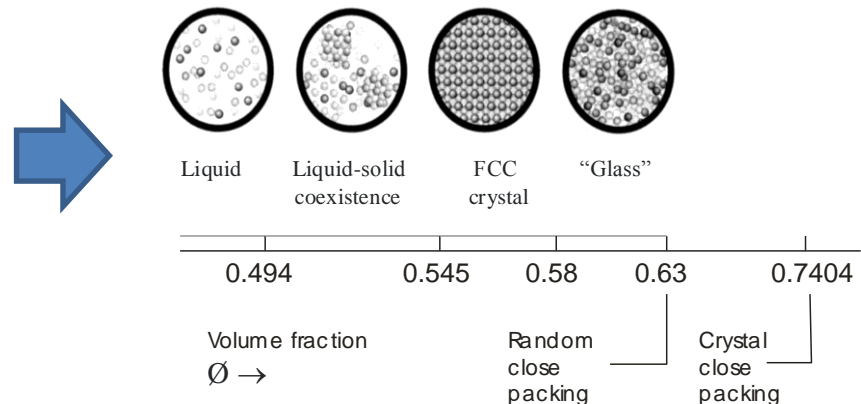

# Measurement approach – 9/9

The experiment consists one control base and two interchangeable samples modules (each sample module contains three capillary cells). Run one experiment module per week. Microscopic observation is expected to require 1–4 days for each sample module.

1. Inspect samples (to determine whether or not large bubbles exist in the sample capillary cells).
2. The first sample to be run will be selected based on the above bubble size observations; from this, feedback will be provided to the crew on which sample well strips to install in the microscope.
3. Mix sample wells using motorized magnetic stir bar in the condenser until that particles are randomized; ground testing will be used in advance of the flight to ensure that 2 minutes per capillary cell is appropriate.
4. Define XYZ offsets (assembly alignment per ACE-T-1 method) and camera parameters are adjusted using 25x objective.
5. Survey capillary cell(s) at 25x to determine primary test locations (select locations away from stir bar or bubble) and secondary region of interest.
6. Move to first regions of interest (ROI). Using 40x air objective, focus on the bottom surface of the particle assembled structure.
7. Operator records camera parameters using the 40x air objective and records best z-depth at each primary test location (record at five z-depths (*e.g.* 2, 4, 6, 8, and 10 microns) each region of interest (ROI)).
8. We would like to use 40x air objective at intervals of 3 hours for 4-5 days. Addition experimentation with the GIU will tell us if we need to switch to 63x air objective to see the bond structures.
9. Imaging goal is to characterize and analyze the assembled formation/structures.

## Expected results and how they will advance the field (1/2)

The microgravity environment on the ISS will provide an understanding of the fundamental physics of anisotropic particles, which in turn will tell us what kinds of structures are possible to fabricate. This enables us to prescreen which high-value products merit the investment of manufacturing resources.



# Expected results and how the expected results will advance the field (2/2)

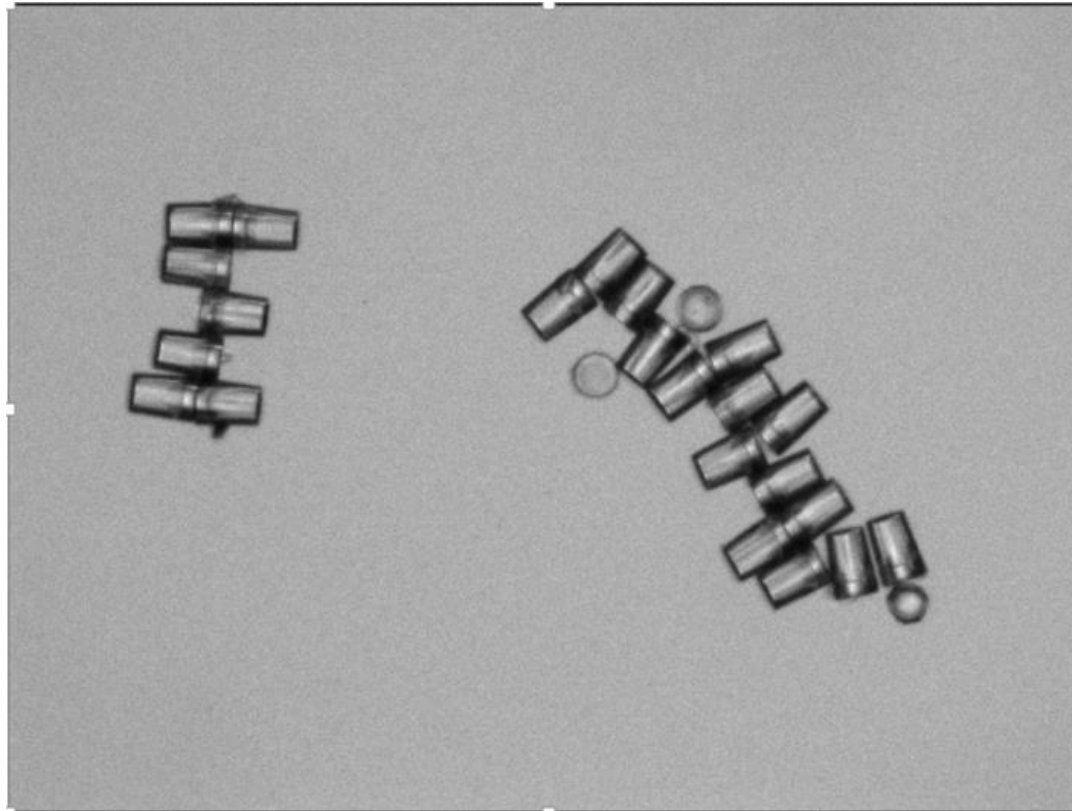

↑ 2D experiments possible on Earth.

On ISS self-assembly will be observed and understood in 3D.

**Prof. Chang-Soo Lee**

Department of Chemical Engineering,  
Chungnam National University (CNU),  
South Korea

# Earth benefits / spin-off applications

The ACE-T-1 investigation seeks to answer fundamental questions about behaviors of colloids, helping scientists to understand how to control, change, and even reverse interactions between tiny particles. This knowledge is crucial for developing self-assembling, self-moving, and self-replicating technologies for use on Earth. It is anticipated that this novel fabrication approach can be applied to produce novel functional material in various applications such as self-assembly, photonics, diagnostics, and drug-delivery.



# ACE-T1

Increment 45/46 Science Symposium

**BACKUP SLIDES**

# ACE-T1 samples, 1/2

Maximum fluid volume of each sample well There are 10 wells per sample cell (Maximum volume of each sample cell well = approximately 1.25 $\mu$ L)

In the case of well #2, 6, 10, stir bar (1mm length and 0.076mm in diameter) and external magnet for mixing can be added to each well, which increase the contact frequency of microparticles.

## Particle information

Janus particles bearing segregated hydrophobic and hydrophilic parts are composed of TMPTA (trimethylolpropane triacrylate) with lauryl acrylate as comonomer and PEG-DA (polyethyleneglycol diacrylate), respectively.

## - Schemes for particle assembly

1. Type A (Well #1 – #2): Cylindrical Janus particles with 5 × 5  $\mu$ m dimension (mixing/ non-mixing)
  2. Type B (Well #3 – #6): Cylindrical Janus particles with 20 × 30  $\mu$ m dimension (mixing/ non-mixing)
  3. Type C (Well #7 – #10): Convex Janus particles with 20 × 30  $\mu$ m dimension (mixing/ non-mixing)
- The Janus particle with different ratio of hydrophobic/hydrophilic part is prepared (e.g., hydrophobic/hydrophilic part = 7:3, 5:5, 3:7)

## Media Solutions

Media solution = De-ionized water (0.01% Tween20 as surfactant can be used to prevent adhesion of the particle on vessel)

Well #	Sample Cell
1 Particle Media Particle Volume Fraction	* Mixing with motorized stir bar Cylindrical Janus particle (hydrophobic/hydrophilic ratio=5:5), Size: 5 $\mu$ m × 5 $\mu$ m (width x height, A.R=1, cylindrical shaped Janus particle) De-ionized water 0.0025-0.005 (50-100 particles/1.25 $\mu$ L)
2 Particle Media Particle Volume Fraction	* No Mixing Cylindrical Janus particle (hydrophobic/hydrophilic ratio=5:5), Size: 5 $\mu$ m × 5 $\mu$ m (width x height, A.R=1, cylindrical shaped Janus particle) De-ionized water 0.0025-0.005 (50-100 particles/1.25 $\mu$ L)
3 Particle Media Particle Volume Fraction	* Mixing with motorized stir bar Cylindrical Janus particle (hydrophobic/hydrophilic ratio=3:7), Size: 20 $\mu$ m × 30 $\mu$ m (width x height, A.R=1.5, cylindrical shaped Janus particle) De-ionized water 0.0025-0.005 (50-100 particles/1.25 $\mu$ L)
4 Particle Media Particle Volume Fraction	* Mixing with motorized stir bar Cylindrical Janus particle (hydrophobic/hydrophilic ratio=5:5), Size: 20 $\mu$ m × 30 $\mu$ m (width x height, A.R=1.5, cylindrical shaped Janus particle) De-ionized water 0.0025-0.005 (50-100 particles/1.25 $\mu$ L)
5 Particle Media Particle Volume Fraction	* Mixing with motorized stir bar Cylindrical Janus particle (hydrophobic/hydrophilic ratio=7:3), Size: 20 $\mu$ m × 30 $\mu$ m (width x height, A.R=1.5, cylindrical shaped Janus particle) De-ionized water 0.0025-0.005 (50-100 particles/1.25 $\mu$ L)



## ACE-T1 samples, 2/2

6 Particle Media Particle Volume Fraction	* No Mixing Convex Janus particle (hydrophobic/hydrophilic ratio=3:7), Size: 20 $\mu\text{m}$ x 30 $\mu\text{m}$ (width x height, A.R=1.5, convex top) De-ionized water 0.0025-0.005 (50-100 particles/1.25 $\mu\text{L}$ )
7 Particle Media Particle Volume Fraction	* Mixing with motorized stir bar Convex Janus particle (hydrophobic/hydrophilic ratio=3:7), Size: 20 $\mu\text{m}$ x 30 $\mu\text{m}$ (width x height, A.R=1.5, convex top) De-ionized water 0.0025-0.005 (50-100 particles/1.25 $\mu\text{L}$ )
8 Particle Media Particle Volume Fraction	* Mixing with motorized stir bar Convex Janus particle (hydrophobic/hydrophilic ratio=5:5), Size: 20 $\mu\text{m}$ x 30 $\mu\text{m}$ (width x height, A.R=1.5, convex top) De-ionized water 0.0025-0.005 (50-100 particles/1.25 $\mu\text{L}$ )
9 Particle Media Particle Volume Fraction	* Mixing with motorized stir bar Convex Janus particle (hydrophobic/hydrophilic ratio=7:3), Size: 20 $\mu\text{m}$ x 30 $\mu\text{m}$ (width x height, A.R=1.5, convex top) De-ionized water 0.0025-0.005 (50-100 particles/1.25 $\mu\text{L}$ )
10 Particle Media Particle Volume Fraction	* No Mixing Convex Janus particle (hydrophobic/hydrophilic ratio=5:5), Size: 20 $\mu\text{m}$ x 30 $\mu\text{m}$ (width x height, A.R=1.5, convex top) De-ionized water 0.0025-0.005 (50-100 particles/1.25 $\mu\text{L}$ )

# Mission Success Criteria for ACE-T1 (Lee)

Success Level	Accomplishment
Minimum Success	Minimal success can be evaluated by successful loading of particles into cells, monitoring of the particles, and capturing of the particle or assembly images under the microgravity environment although particle assembly has not happened. In addition, images of assembly of microparticles are captured at 3 hour intervals over a period of 1 day.
Significant Success	Significant success would be realized if all plans were showing possibility of assembly, but not fully accomplished. There are small portion of the particles assembly in a cell while some particles are moving individually because of lack of attractive forces ( <i>e.g.</i> , chemical attraction, depletion force, surface tension force and so on). In addition, images of assembly of microparticles are captured at 3 hour intervals over a period of 3 days.
Complete Success	Complete success is that most of particles in all conditions would be directionally assembled by attractive force. We can obtain various configurations of assembled types from dimer to multimer or time-lapse images including the kinetic information of the assembly under the microgravity environment. In addition, images of assembly of microparticles are captured at 3 hour intervals over a period of 7 days.





# Microgravity Justification

- Formation of colloidal structures is profoundly affected by gravity via sedimentation processes. Chaikin and Russel have already demonstrated this effect in space experiments exploring the simplest of all entropic transitions, the hard-sphere liquid-solid phase transition.
- Sedimentation causes particles to fall so rapidly that there is insufficient time for particles to explore the full phase space of positions and velocities that are required for thermodynamic assembly processes. A substantial particle concentration gradient arises in the earthbound sample.

$$h = \frac{kT}{\Delta\rho V g}$$

$h$  = gravitational height

$kT$  = Thermal Energy of system

$\Delta\rho$  is the density difference between the particles and the background fluid

$V$  is the particle volume

$g$  is the gravitational acceleration

$h$  ranges from a few microns for the case of polystyrene in water to a fraction of a micron for most of the other particles we consider. Our particles are usually of order 1 micron in diameter.



# Microgravity Justification

(continued)

- In addition, the shear forces of fluid flow due to the sedimenting particles is often sufficient to break structures that are forming thermodynamically.
- The solvents we plan to use (such as water) are restricted by various factors, for example by our need to fix the colloidal structures in space. Almost all of the particles of future interest are either too heavy or too light compared to water.
- Sample equilibration often requires ~1 to 12 hours. Structure growth sometimes continues for one to two more weeks after the initiation process. These processes are too slow for a drop tower or an airplane.
- Space station or space shuttle provides an environment where microgravity is sustained long enough to allow these experiments to be conducted. The samples can be homogenized, and then allowed to develop in the microgravity environment. Their structures and optical properties can be measured. For most samples we are contemplating, the density mismatch between particle and background fluid is large (e.g.  $> 1.1 \times$ ). Microgravity dramatically reduces these differences and permits true equilibrium processes to occur.