

NASA/TM—2015-218885



Applicability of STEM-RTG and High-Power SRG Power Systems to the Discovery and Scout Mission Capabilities Expansion (DSMCE) Study of ASRG-Based Missions

Anthony J. Colozza
Vantage Partners, LLC, Brook Park, Ohio

Robert L. Cataldo
Glenn Research Center, Cleveland, Ohio

NASA STI Program . . . in Profile

Since its founding, NASA has been dedicated to the advancement of aeronautics and space science. The NASA Scientific and Technical Information (STI) Program plays a key part in helping NASA maintain this important role.

The NASA STI Program operates under the auspices of the Agency Chief Information Officer. It collects, organizes, provides for archiving, and disseminates NASA's STI. The NASA STI Program provides access to the NASA Technical Report Server—Registered (NTRS Reg) and NASA Technical Report Server—Public (NTRS) thus providing one of the largest collections of aeronautical and space science STI in the world. Results are published in both non-NASA channels and by NASA in the NASA STI Report Series, which includes the following report types:

- **TECHNICAL PUBLICATION.** Reports of completed research or a major significant phase of research that present the results of NASA programs and include extensive data or theoretical analysis. Includes compilations of significant scientific and technical data and information deemed to be of continuing reference value. NASA counter-part of peer-reviewed formal professional papers, but has less stringent limitations on manuscript length and extent of graphic presentations.
- **TECHNICAL MEMORANDUM.** Scientific and technical findings that are preliminary or of specialized interest, e.g., “quick-release” reports, working papers, and bibliographies that contain minimal annotation. Does not contain extensive analysis.
- **CONTRACTOR REPORT.** Scientific and technical findings by NASA-sponsored contractors and grantees.
- **CONFERENCE PUBLICATION.** Collected papers from scientific and technical conferences, symposia, seminars, or other meetings sponsored or co-sponsored by NASA.
- **SPECIAL PUBLICATION.** Scientific, technical, or historical information from NASA programs, projects, and missions, often concerned with subjects having substantial public interest.
- **TECHNICAL TRANSLATION.** English-language translations of foreign scientific and technical material pertinent to NASA's mission.

For more information about the NASA STI program, see the following:

- Access the NASA STI program home page at <http://www.sti.nasa.gov>
- E-mail your question to help@sti.nasa.gov
- Fax your question to the NASA STI Information Desk at 757-864-6500
- Telephone the NASA STI Information Desk at 757-864-9658
- Write to:
NASA STI Program
Mail Stop 148
NASA Langley Research Center
Hampton, VA 23681-2199



Applicability of STEM-RTG and High-Power SRG Power Systems to the Discovery and Scout Mission Capabilities Expansion (DSMCE) Study of ASRG-Based Missions

Anthony J. Colozza
Vantage Partners, LLC, Brook Park, Ohio

Robert L. Cataldo
Glenn Research Center, Cleveland, Ohio

National Aeronautics and
Space Administration

Glenn Research Center
Cleveland, Ohio 44135

Trade names and trademarks are used in this report for identification only. Their usage does not constitute an official endorsement, either expressed or implied, by the National Aeronautics and Space Administration.

Level of Review: This material has been technically reviewed by technical management.

Available from

NASA STI Program
Mail Stop 148
NASA Langley Research Center
Hampton, VA 23681-2199

National Technical Information Service
5285 Port Royal Road
Springfield, VA 22161
703-605-6000

This report is available in electronic form at <http://www.sti.nasa.gov/> and <http://ntrs.nasa.gov/>

Applicability of STEM-RTG and High-Power SRG Power Systems to the Discovery and Scout Mission Capabilities Expansion (DSMCE) Study of ASRG-Based Missions

Anthony J. Colozza
Vantage Partners, LLC
Brook Park, Ohio 44142

Robert L. Cataldo
National Aeronautics and Space Administration
Glenn Research Center
Cleveland, Ohio 44135

Abstract

This study looks at the applicability of utilizing the Segmented Thermoelectric Modular Radioisotope Thermoelectric Generator (STEM-RTG) or a high-power radioisotope generator to replace the Advanced Stirling Radioisotope Generator (ASRG), which had been identified as the baseline power system for a number of planetary exploration mission studies. Nine different Discovery-Class missions were examined to determine the applicability of either the STEM-RTG or the high-power SRG power systems in replacing the ASRG. The nine missions covered exploration across the solar system and included orbiting spacecraft, landers and rovers. Based on the evaluation a ranking of the applicability of each alternate power system to the proposed missions was made.

Study Purpose

The objective of this study was to assess potential benefits that a new radioisotope power system concept might have on a Discovery-class NASA space science mission. In 2007, nine mission concept studies (discussed in more detail later) were awarded that focused on missions that would be enabled by the implementation of the Advanced Stirling Radioisotope Generator (ASRG), which was then in a late phase of development. The positive results of these concept studies led to NASA offering the ASRG for the Discovery 12 Announcement of Opportunity (AO) in 2010.

Since that time, budgetary realignments within the NASA Science Mission Directorate (SMD) ended the ASRG flight project; however, a Stirling technology maturation effort continues to be funded, along with thermoelectric technology development and maturation activities.

During the summer of 2014, a fresh look at the potential suite of SMD missions and corresponding power requirements was undertaken as part of the recent NASA Nuclear Power Assessment Study (NPAS) activity, also described later. In order to increase the database of radioisotope-enabled Discovery-class mission concepts beyond those proposed for Discovery 12, a “look back” at the DSMCE studies was undertaken to characterize the pros and cons of the system concepts developed during the NPAS as contrasted to the original ASRG mission concepts.

Background

In the summer of 2014 NASA completed a study evaluating the potential benefits of advanced radioisotope power systems (RPS) and small fission power systems to future NASA robotic science missions. During the execution of the Nuclear Power Assessment Study (NPAS), several concepts for new RPS were evaluated over a range of mission classes, including Discovery, New Frontiers and Flagship opportunities. In 2010, the Announcement of Opportunity (AO) for Discovery 12 allotted up to,

two Advanced Stirling Radioisotope Generators (ASRG) as one of the four NASA incentivized technologies offered to proposers.

In 2007, NASA SMD initiated a NASA Research Opportunity in Space and Earth Science (ROSES) solicitation seeking proposals for a Discovery and Scout Mission Capabilities Expansion (DSMCE) study. Nine proposals were downselected to assess the potential application of the ASRG and to evaluate the benefits to their proposed mission. The encouraging results of the studies paved way for the ASRG being offered in the Discovery 12 AO; two of the final three competing proposals that were awarded Phase A funding utilized two ASRGs each in their mission concepts.

At the time of the studies, the predicted ASRG mass and mission power provided as guidance for the DSMCE studies were 24 kg and 145 We beginning of mission (BOM) power, respectively. As the ASRG design matured, the predicted BOM power level decreased to ~135 We and the mass increased to 32 kg. Since the ASRG flight project was subsequently cancelled, the opportunity emerged to revisit future mission power requirements for a wide spectrum of potential SMD missions, with a goal of ascertaining whether a single unit could provide sufficient power output to serve these missions. As part of the NPAS effort, the RPS Program's Mission Analysis Team (MAT) assessed past Discovery, New Frontiers and Flagship missions as well as the National Research Council *Visions and Voyages for Planetary Science in the Decade 2013 to 2022* decadal survey report for power requirements with hope of identifying a strategic power level that could be implemented on a host of missions using a single design.

After compiling the power requirements of all the relevant mission concepts that were enabled by or could benefit from RPS, a candidate unit size of approximately 300 We emerged as a plausible solution. In the assessment of the three classes of SMD missions, the Discovery class fell within ~250 to 300 We; New Frontiers ~300 to 600 We, and Flagships between 900 to 1200 We. In addition, the number of power systems to be integrated on a spacecraft was limited to four due to typical available area on a spacecraft body and the challenges of integrating multiple units at the launch site.

Thus if a new system were to be developed, a 300 We end-of-mission (EOM) power output would be desirable (based on a 14-year mission timeline), where a single unit would be used on Discovery class missions, 1 to 2 units on New Frontiers and 3 to 4 units on Flagship missions. Two concept designs were developed for the NPAS: a high-power Stirling Radioisotope Generator (SRG) and a Segmented Thermoelectric Modular Radioisotope Thermoelectric Generator (STEM-RTG).

To better validate the attributes of these concepts and how they actually provide benefit to various missions, a task was initiated to quantify these benefits by taking a look at the representative DSMCE studies for Discovery that originally utilized the 145 We ASRGs and retrofit these concepts with ~300 We SRG and the STEM-RTG.

Introduction

The Advanced Stirling Radioisotope Generator (ASRG) power system was the baseline power system identified for a number of potential space missions. However, its recent cancellation means that other potential power system will need to be identified that could meet the requirements of those (or similar) future mission.

The ASRG system, illustrated in Figure 1, would generate electrical power through a Stirling engine operating off of two General Purpose Heat Source (GPHS) blocks that contain the system's plutonium dioxide fuel. The system shown is based on the configuration established through the ASRG design process. The specifications of the ASRG are given in Table 1.

The Stirling engine within the ASRG converts heat from the isotope blocks to provide electrical power. Each radioisotope block, GPHS, provides 250 W of thermal power at their beginning of life. The blocks are comprised of a number of plutonium dioxide pellets, as illustrated in Figure 2. Each block measures 9.948 by 9.32 by 5.82 cm and has a mass of 1.44 kg (Ref. 2).

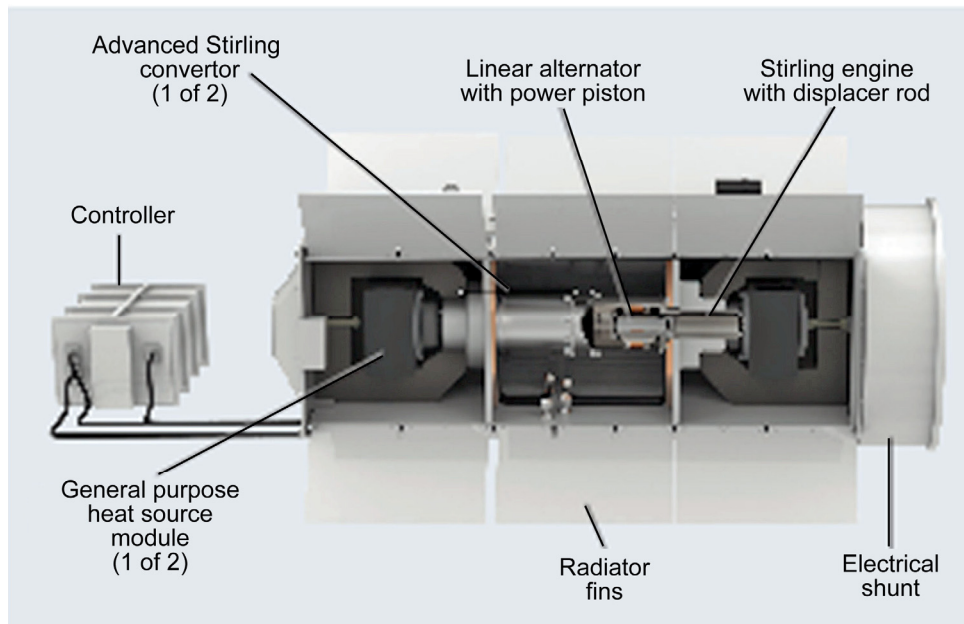

Figure 1.—Illustration of ASRG Arrangement and Components (Ref. 1).

TABLE 1.—ASRG SPECIFICATIONS (REF. 1)

Property	Value
Beginning of life output power	130 W
Thermal to electrical conversion efficiency	26 percent
Dimensions	0.76 by 0.46 by 39 m
Mass	32 kg

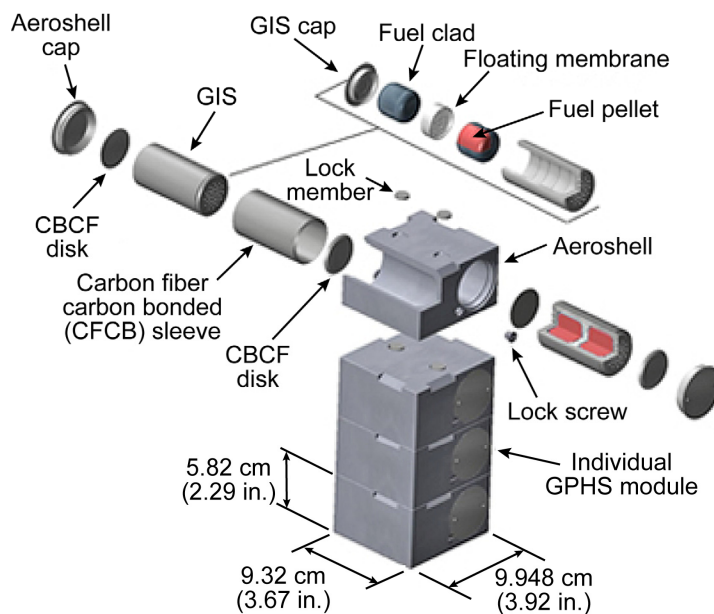

Figure 2

Figure 2.—GPHS Block Assembly Drawing (Ref. 2).

Other radioisotope-based power systems can be considered as alternatives to mission studies that were designed around the ASRG system. Two potential systems that may be applicable are the STEM-RTG and the high power SRG. These systems are in the early stages of development but have projected characteristics similar to that of the ASTG and therefore may be applicable to missions that utilized the ASRG.

Advanced Radioisotope Thermoelectric Generator

The Jet Propulsion Laboratory and Aerojet-Rockedyne devised the STEM-RTG system as a potential follow-on to the Multi-Mission Radioisotope Thermoelectric Generator (MMRTG), now in use on Mars by the Curiosity rover. The STEM-RTG concept is based on thermoelectric heat-to-power conversion technology and would provide increased performance over the MMRTG in both reduced mass and higher efficiency. This notional system is illustrated in Figure 3.

The base number of GPHS blocks used as the heat source within this system can vary from 8 up to 18 depending on the power needs of the mission concept. The estimated specifications and operational performance of the STEM-RTG are given in Table 2.

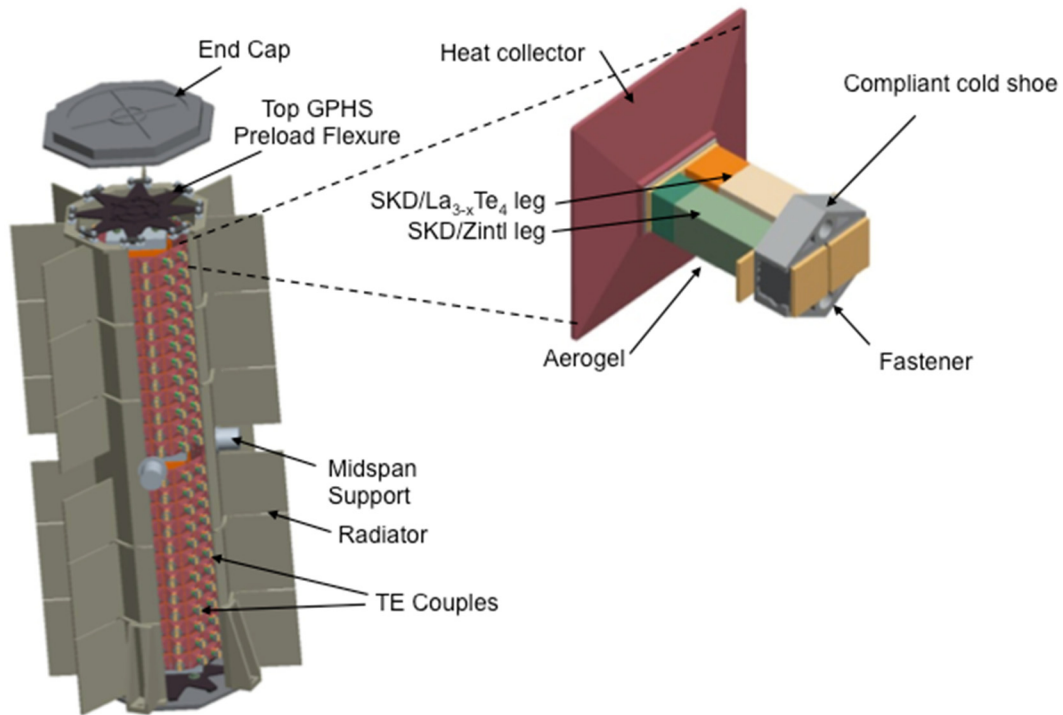

Figure 3.—Illustration of the STEM-RTG Power System Conceptual Design (Ref. 3).

TABLE 2.—STEM-RTG SPECIFICATIONS (REF. 3)

Property	Value			
Number of GPHS blocks	8	12	16	18
Beginning of life power	217 W	334 W	454 W	513 W
Beginning of mission power	207 W	319 W	432 W	489 W
End of mission power (17 years)	166 W	255 W	346 W	391 W
Dimensions length, max diameter	0.58 m, 0.52 m	0.83 m, 0.53 m	1.07 m, 0.54 m	1.19 m, 0.54 m
Heat rejection temp. (sink temp. 4 K, 270 K)	459 K, 472 K	459 K, 472 K	460 K, 473 K	460 K, 473 K
Beginning of life specific power	7.5 W/kg	8.0 W/kg	8.4 W/kg	8.6 W/kg
Mass	29.2 kg	42.2 kg	54.2 kg	60.3 kg
Beginning of life efficiency	10.9%	11.1%	11.3%	11.4%

High Power SRG

The high-power SRG would be a follow-on to the ASRG but with the prospect of operating at higher power levels, by utilizing more GPHS blocks. The notional SRG system could utilize from 2 to 8 GPHS blocks to provide heat to operate the Stirling engines. This conceptual power system is still in its early design stages of development. Initial designs borrow heavily from the ASRG in components and operating conditions. However, advanced materials and components are being considered to increase the performance by reducing mass and thereby increasing the specific power of the system. A conceptual design is illustrated in Figure 4.

The estimated performance and specifications of the SRG conceptual design are given in Table 3.

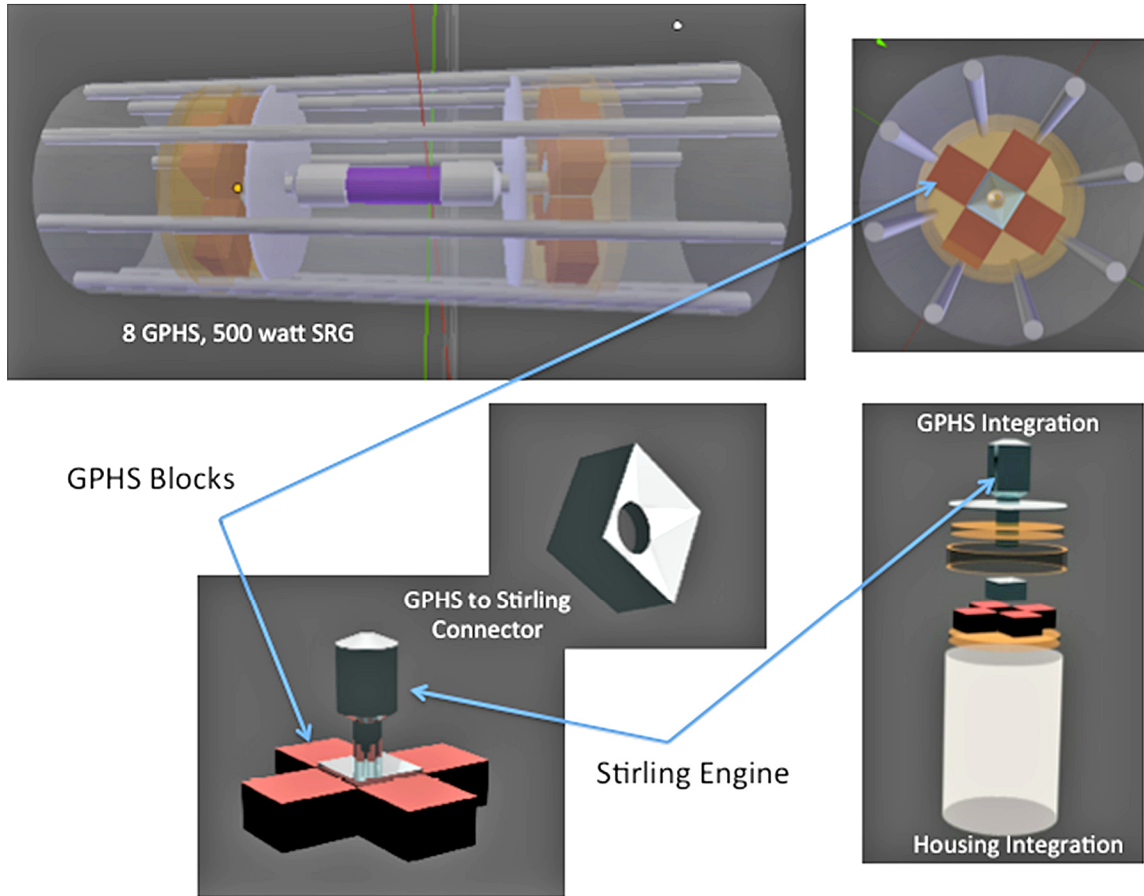

Figure 4.—High Power SRG Conceptual Illustration (Ref. 3).

TABLE 3.—SRG SPECIFICATIONS (REF. 3)

Property	Value			
	2	4	6	8
Number of GPHS blocks	2	4	6	8
Beginning of life power	116 W	215 W	331 W	456 W
Beginning of mission power	113 W	207 W	319 W	440 W
End of mission power (17 years)	93 W	173 W	266 W	366 W
Dimensions length, max diameter	0.19 m, 0.50 m	0.33 m, 0.45 m	0.33 m, 0.65 m	0.36 m, 0.95 m
Heat rejection temp. (sink temp. 4 K, 270 K)	400 K, 440 K	428 K, 468 K	428 K, 468 K	408 K, 448 K
Beginning of life specific power	7.5 W/kg	7.5 W/kg	7.9 W/kg	7.9 W/kg
Mass	17.3 kg	32.0 kg	46.8 kg	64.6 kg
Beginning of life efficiency	26.0%	24.0%	24.7%	25.5%

Mission Options

The predicted output power level range of the ASRG, as well as the STEM-RTG and SRG, matches well with Discovery-class missions. These missions are designed to be lower cost, highly focused science missions, selected on a short timescale every two to four years. This type of mission utilizes spacecraft and surface vehicles that generally utilize less than 1 kw of electrical power, with many in the sub-500 W level. Also the lifetimes of planetary science missions, which are on the order of multiple years, fit well with RPS. A listing of past Discovery mission and their power requirements is given in Table 4.

All of the previous and scheduled Discovery missions (with InSight due to launch in 2016) utilized a photovoltaic array/battery system for electrical power. However, future missions are likely to continue to extend the Discovery program further out into the solar system where photovoltaic systems may not be practical. Therefore alternative power systems, such as RPS, can provide the ability to meet these mission needs. The ASRG power system was identified as a prime candidate for a number of potential future Discovery class missions. These missions are listed in Table 5.

Since the ASRG flight development project has been stopped, the mission concepts that were based on utilizing it as a power system should be reexamined to see if other power systems would be applicable. Each of the missions listed in Table 5 could also potentially utilize either the STEM-RTG or SRG as a replacement for the ASRG. An initial evaluation of substituting these potential power systems for each of those missions is given in the following sections.

TABLE 4.—PAST AND PLANNED DISCOVERY MISSIONS (REF. 4)

Mission	Approximate launch mass, kg	Base power output	Planned lifetime	Power system
Pathfinder	900	<25 W	90 days	PV/Battery
NEAR	500	1800 W (at 1 AU) 880 W (at 1.5 AU) <100 W (S/C Cruise)	6 years	PV/Battery
Lunar prospector	300	200 W	1 year	PV/Battery
Stardust	400	330 W	7 years	PV/Battery
Genesis	650	260 W	3 years	PV/Battery
CONTOUR	1000	200 W	6 years	PV/Battery
Messenger	1200	650 W	10 years	PV/Battery
Deep Impact	650	620 W (spacecraft)	6 years	PV/Battery
Dawn	1300	1300 W	10 years	PV/Battery
Kepler	900	1100 W	4 years	PV/Battery
GRAIL	600	800 W	1 year	PV/Battery
InSight (launch in 2016)	700	450 W	2 years	PV/Battery

TABLE 5.—FUTURE DISCOVER MISSION OPTIONS

Mission	Approximate launch mass, kg	Base power output	Planned lifetime, years
DSMCE 1: Venus Atmospheric Long-Duration Observatory for in situ Research (VALOR)	1500	140 W (on Balloon)	1
DSMCE 2: Lunar Lander (EXOMOON)	1500	143 W	1
DSMCE 3: Mars Polar Ice Borehole (Kuklos)	900	160.5 W Nominal 600–900 W Drill	3
DSMCE 4: Lunar Polar Volatile Explorer (JEDI)	3600	1160 Max W, 280 W Nominal	1.5
DSMCE 5: Io Volcano Observer (IVO)	2400	262 W	8
DSMCE 6: Trojan Asteroid Lander (Ilion)	1500	256 W	11
DSMCE 7: Comet Coma Rendezvous Sample Return (CCRSR)	1500	202 W	14
DSMCE 8: Titan Mare Explorer (TiME)	1500	242 W	8
DSMCE 9: Comet Hopper (CHopper)	1400	267 W	10

DSMCE 1: Venus Atmospheric Long-Duration Observatory for In-Situ Research (VALOR) (Ref. 5)

The VALOR mission would explore the upper atmosphere of Venus at a level of approximately 55 km for a minimum of 30 Earth days. This would be accomplished by utilizing a super-pressure balloon, as illustrated in Figure 5, which would operate from the mid-latitudes to the pole. The science goals for the mission concept are to investigate the key processes, composition and dynamics of the Venus atmosphere. This included measuring reactive species within the atmosphere, Nobel gases and their isotopes and light gas species. The mission would have also provided meteorological measurements, lighting monitoring and global circulation mapping. To accomplish this the primary science instruments would have included:

- Gas Chromatograph Mass Spectrometer
- Atmospheric Structure Instrument
- Radio Tracking
- Lightning Detector



Figure 5.—Venus Super-Pressure Balloon Concept Illustration (Ref. 5).

The transit to Venus is illustrated in Figure 6. The transit shows that the closest approach to the Sun would have occurred at Venus.

The ASRG power system was selected as the proposed balloon power system since it could provide long life power for the 30-day baseline mission under nighttime and low-Sun angle operation. The design used a single ASRG located on the gondola as shown in Figure 7.

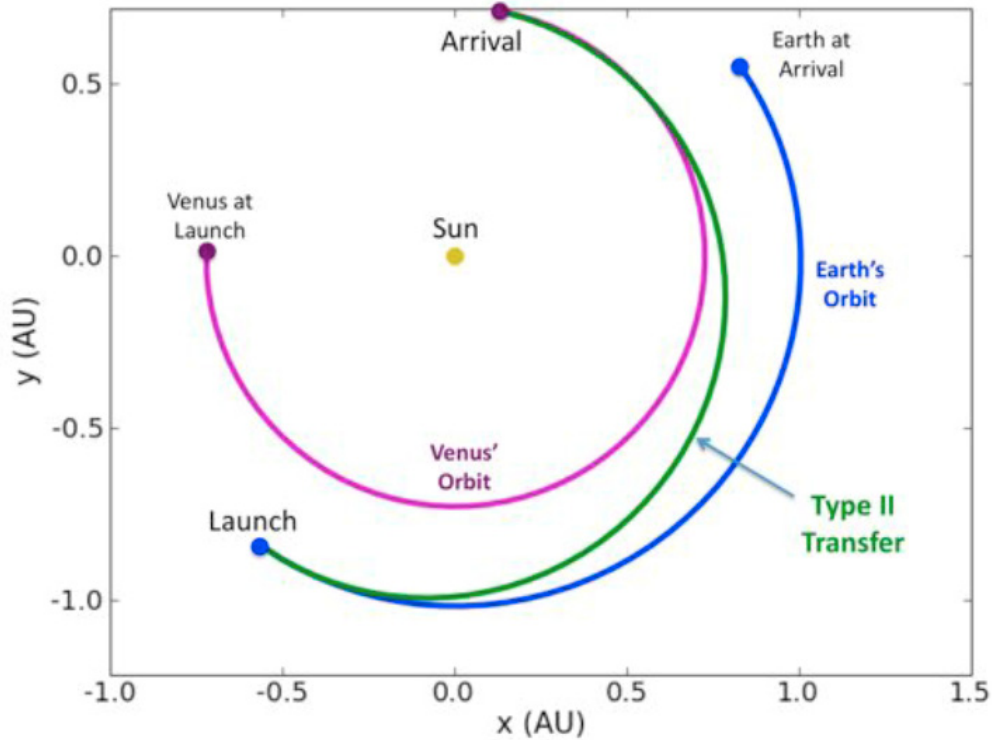

Figure 6.—Proposed Earth to Venus Transfer Orbit for the VALOR Mission (Ref. 5).

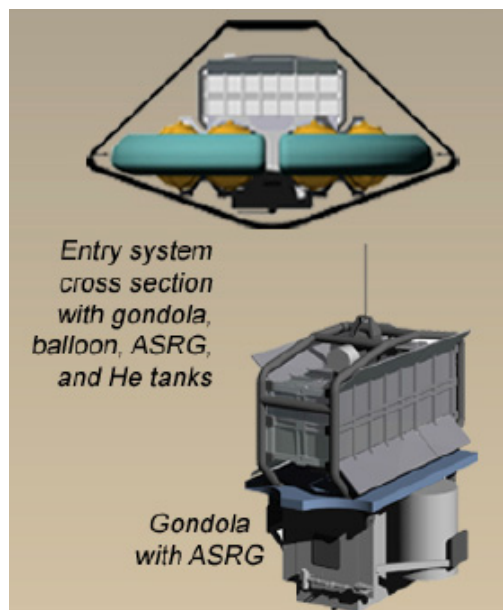

Figure 7.—ASRG Location in VALOR Concept Aeroshell and Gondola (Ref. 5).

The ASRG would provide up to 140 W of continuous power during operation within the Venus atmosphere. The total entry system mass was estimated to be 931 kg with a 23 percent contingency. The operating pressure within the Venus atmosphere would be 0.5 bar of CO₂. The atmosphere also contains sulfuric acid (H₂SO₄) droplets, so any exposed surfaces of the power system would need to be resistant to this corrosive acid. Other reactive gasses that are expected to be encountered would include water vapor (H₂O), carbon monoxide (CO) and carbonyl sulfide (OCS).

The ASRG power system limited the entry g-load to 30 g's. The ASRG also required a thermal interface to remove heat from the aeroshell during transit to Venus, and the aeroshell must be capable of absorbing the waste heat generated by the ASRG during entry until the aeroshell separates during descent. The waste heat provided by the ASRG was estimated to be 360 W with a heat rejection temperature of 80 °C. The operating conditions at the design altitude for the balloon are 0.5 bar atmospheric pressure with a temperature of 30 °C.

For the VALOR mission either the eight GPHS block STEM-RTG power system or the four GPHS block SRG power system would be a viable candidate to replace the ASRG. The eight-block STEM-RTG system and four-block SRG system have an estimated beginning of mission power of 207 W, which is greater than the required 140 W identified for the mission. Since the mission duration would be relatively short, the power output of either the STEM-RTG or SRG would be above or near the 200 W level throughout the mission. The increased power could provide opportunities for increased science operations. The estimated masses of the STEM-RTG and SRG power systems are 29.2 and 32 kg, respectively. However, the ASRG mass was not a significant driver for the mission design. Therefore, a change in the mass of the power system should not significantly impact the mission. A change in mass would affect the Aerostat sizing somewhat and could provide extra mass for science payload. Therefore, providing extra power could potentially enable additional science instruments to be carried onboard the gondola.

Potential concerns with the STEM-RTG and SRG systems as a replacement for the ASRG would be in the design of the spacecraft and aeroshell during transit. The added waste heat generated from these systems would need to be accommodated to maintain the interior temperature of the spacecraft during transit within acceptable levels. Upon entry into the Venus atmosphere, the aeroshell would need to be sufficiently sized to absorb the additional waste heat. Within the Venus atmosphere the extra waste heat should not be a concern. Also, since only a single ASRG was being used, and there was sufficient volume available around it, the larger volume of these systems should not require the configuration within the aeroshell or gondola to be changed.

DSMCE 2: Lunar Polar Volatiles Mobile Lander (ExoMoon) (Ref. 6)

The ExoMoon mission concept would send a lander with limited mobility to explore a lunar polar crater. The lander design is illustrated in Figure 8. The crater would be selected to provide direct-to-Earth communications periodically over a two-week cycle. The lander would utilize a single ASRG for providing power. The main science goals are to determine the character, composition, physical state, abundance and spatial variability of volatiles within a permanently shadowed region on the moon. Also, the lander would be used to determine the history and sources of the volatiles, and the processes for how the volatiles were deposited. The main science instruments include;

- Subsurface sampler
- Mass Spectrometer
- Neutron Spectrometer
- Electric Field Instrument
- Electrostatic Analyzer
- Low Light Spectral Imager

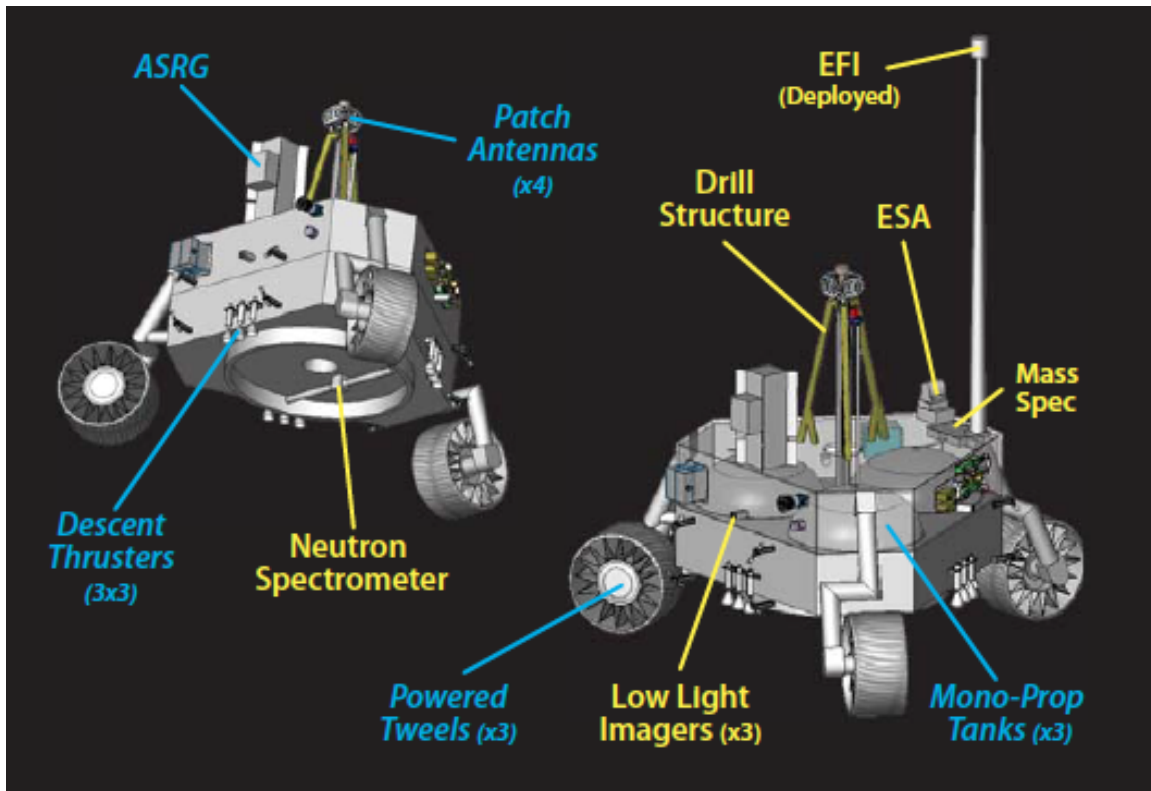

Figure 8.—ExoMoon Mobile Lander Concept Illustration (Ref. 6).

The single ASRG power system would have supplied approximately 143 W of output power continuously throughout the mission with a mass estimate of 32 kg. The ASRG system was selected as the main power source since there would be no solar radiation available within the permanently shaded region of the crater where the lander would be operating within, and the mission duration of greater than 1 year would not be feasible with a purely battery powered vehicle.

The estimated power requirements throughout the ExoMoon mission are given in Table 6.

For the lunar landing phase of the mission, the estimated power requirement would be greater than the output of the ASRG. To accommodate this power level a 20 A-hr battery is utilized to make up the power difference for this phase of the mission. The battery would then be recharged by the ASRG for use later in the mission if needed.

The ASRG would be located on the top surface external to the vehicle, as show in Figure 8. Waste heat is radiated directly to space or the surroundings. No additional thermal interface with the lander is required. The mobile lander is installed within the Atlas V401 launch fairing in an upright orientation as shown in Figure 9.

For the ExoMoon mobile lander, either the eight GPHS block STEM-RTG power system or the four GPHS block SRG power system could be a viable candidate to replace the ASRG. This mission duration is much shorter than the estimated 17-year operational time for the STEM-RTG or SRG. Therefore the EOM output power for both systems is close to the BOM output power. Both the eight-block STEM-RTG system and four GPHS block SRG system have an estimated end of the ExoMoon mission output power of ~200 W, with masses of 29.2 and 32 kg, respectively. Both of these power systems provide similar operating capabilities and mass as the single ASRG systems used in the spacecraft design. Both systems also provide greater output power providing greater power margin for the mission as well as potentially adding additional capabilities to the mission. The increased output power could be used to reduce the size of the battery needed during the landing phase of the mission.

TABLE 6.—EXOMOON MISSION POWER REQUIREMENTS (REF. 6)

Mission	Launch	Trans-Lunar coast	Lunar landing	Science operations
Total required power	85.07 W	121.77 W	231.53 W	77.97 W
ASRG power output	143.00 W	143.00 W	143.00 W	143.00 W
ASRG power margin	41.1%	16.0%	-57.7%	46.0%

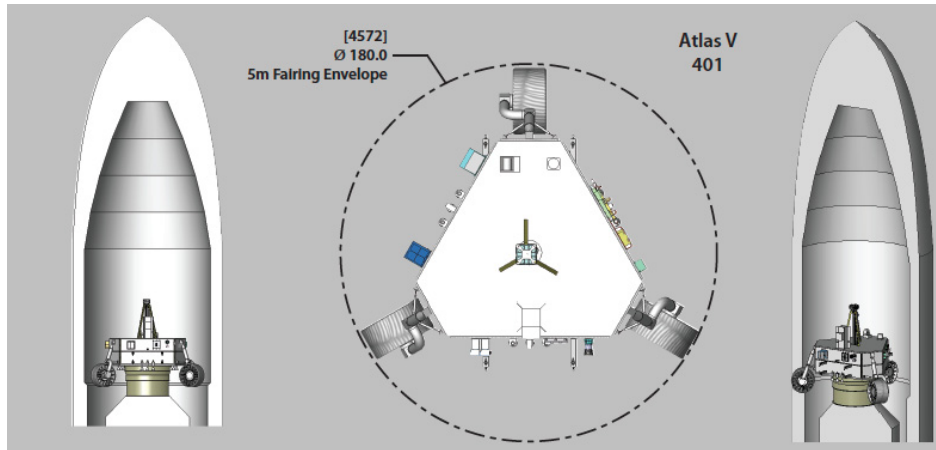

Figure 9.—The ExoMoon Mobile Lander Within the Launch Vehicle Fairing (Ref. 6).

Since the ASRG would be mounted on the exterior of the lander, any change in volume or the increase in waste heat associated with utilizing either the SRG or STEM-RTG should not have a significant effect on the lander design or layout. Also, as shown in Figure 9, there is ample space surrounding the rover within the fairing so any change in dimensions or volume of the power system should not have a significant effect on the launch vehicle.

DSMCE 3: Mars Polar Ice Borehole (Kuklos) (Ref. 7)

The Kuklos mission concept would explore the historical climate, water and atmosphere of Mars by burrowing a hole in the north polar ice of Mars and imaging the strata along the walls of the hole. The system would thermally drill a borehole by melting tens of meters into the north polar cap. During the boring process a camera would record the visible stratigraphy along the borehole walls. A pump would be used to extract the melt water as it is produced and send it to the surface, where additional analysis on its composition would be conducted. The lander was designated to be ASRG powered and operate year round in the Mars polar region. The lander, shown in Figure 10 is based off of the Phoenix lander platform and would utilize two ASRGs.

The operating time on the surface of Mars would be 113+ days. The notional mission timeline for the mission is given in Figure 11. The ASRG was selected as the power system because it enabled continuous year-long drilling capability, and it would allow for low sun angle and wintertime operation at high latitudes. Throughout the mission from launch to operation the highest temperature the ASRG case would reach is 92 °C. This occurs while in transit while on the surface of Mars the maximum temperature is approximately 22 °C. The estimated ASRG case temperature during transit and while on the surface is shown in Figure 12.

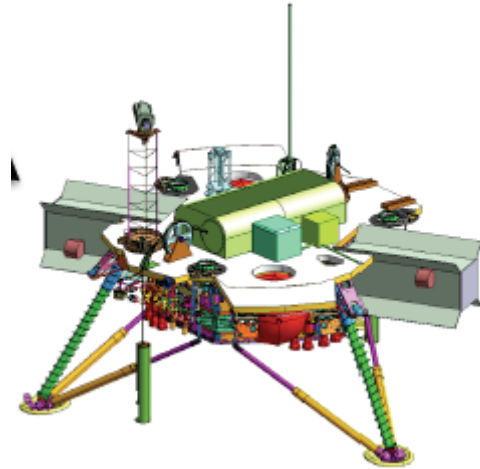

Figure 10.—Kuklos Polar Lander Concept (Ref. 7).

Kuklos ice drilling operations scenario

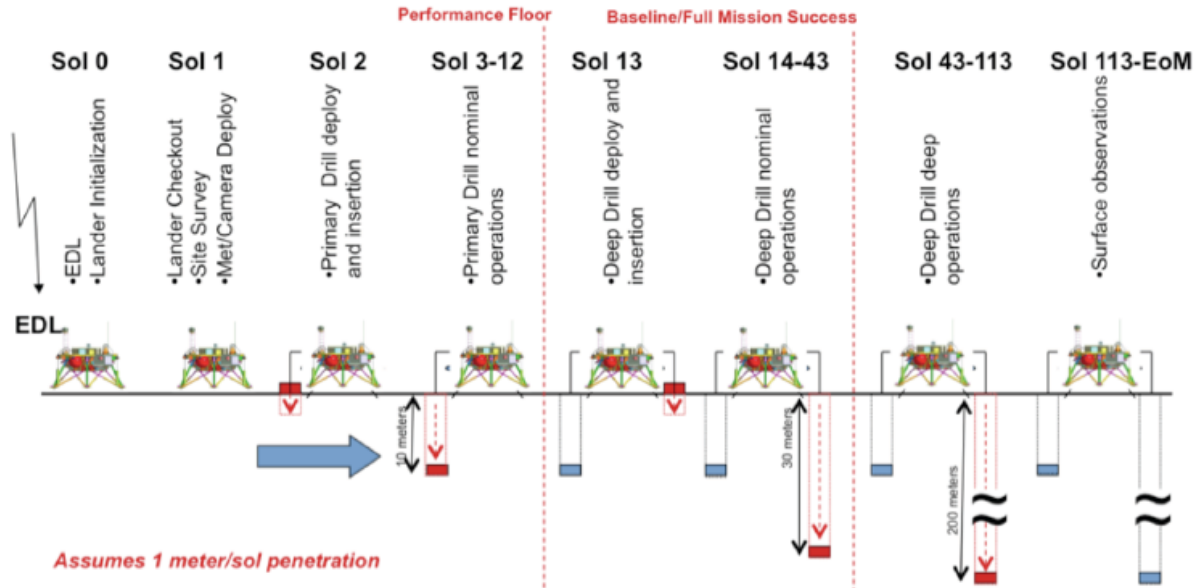

Figure 11.—Kuklos Mission Concept Timeline (Ref. 7).

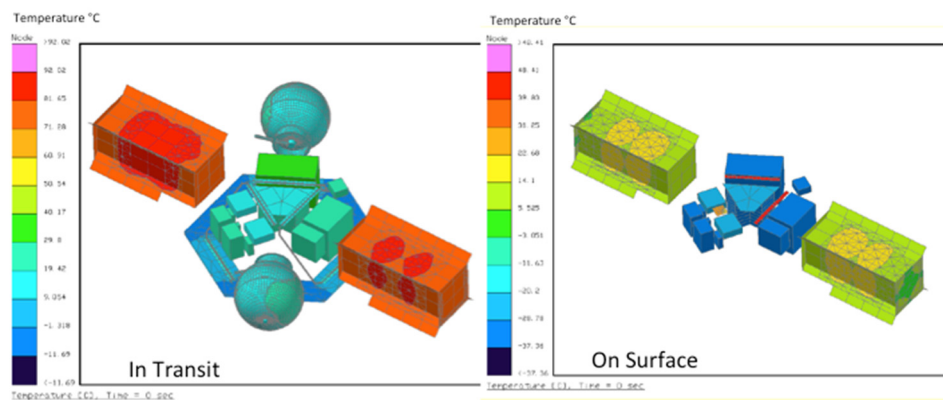

Figure 12.—ASRG Case Temperature for Kuklos While in Transit and on the Surface of Mars (Ref. 7).

The science instruments chosen for the mission concept include two thermal drills with temperature sensors, an IceCam for visualizing the stratigraphy in high resolution, a laser spectrometer for water evaluation, inorganic chemistry analyzer for dust examination, meteorological package for measuring pressure, temperature, humidity and wind, surface imaging camera and a miniature seismometer.

The thermal drill uses electrical power to heat a tip that melts the ice and then pumps up the water to the surface. The drill consumes the largest amount of power of all the science equipment. The best and worst case estimates range from approximately 600 to 900 W and vary with depth. The remaining science equipment and lander systems require a nominal power of 160.5 W.

The power available from the two ASRGs would be 270 W while on the surface and 256 W in cruise. During cruise, the power available from the ASRGs would be augmented by a solar array/battery system to provide the total power needed by the vehicle for this phase of the mission, estimated to be 320 W. The base constant power requirement is 72 W. Additional power up to the design power of 270 W provides the ability to recharge the batteries used for the drilling process. The lander would not utilize the waste heat generated by the ASRGs.

The ASRG mass with contingency was estimated to be 48 kg for the combination of both units.

To meet the lander power requirements with two ASRG systems, batteries were also incorporated. These batteries would be charged by the ASRGs and then used to supplement the ASRG output to provide the full vehicle load power of over 1 kW during drilling. The drilling process would be done incrementally. Once the batteries are discharged, the drilling stops and the ASRGs are used to recharge the batteries for the next drilling sequence.

Because of the volume requirements of the ASRGs, the Phoenix heritage aeroshell was increased in diameter from 2.65 to 3.25 m.

For the Kuklos lander and mission concept, either the twelve GPHS block STEM-RTG power system or the six GPHS block SRG power system could be viable candidates to replace the ASRG. Both the twelve GPHS block STEM-RTG system and six GPHS block SRG system have an estimated beginning of mission output power of 319 W with a mass of 42.2 and 46.8 kg, respectively. Since the mission duration would be relatively short the output power from either power system will be near the beginning of mission power level and above the 270 W that would have been supplied by the ASRGs throughout the mission. The end of mission power levels listed in tables 2 and 3 are for long duration missions of 17 years. For shorter duration mission, such as Kuklos the output power from either the STEM-RTG or SRG would be fairly constant throughout the mission. Both of these power systems provide similar operating capabilities and mass as the two ASRG systems used in the spacecraft design. Some concerns with the STEM-RTG and SRG systems as a replacement for the ASRG would be in the design of the spacecraft and aeroshell during transit. The added waste heat generated from these systems would need to be accommodated to maintain the interior temperature of the spacecraft during transit within acceptable levels. On the Mars surface, the extra waste heat should not be a concern. The larger volume of these systems may require their configuration within the lander to be changed so that it could fit within the aeroshell, or the aeroshell would need to be increased in size to accommodate their larger size.

DSMCE 4: Lunar Polar Volatile Explorer (JEDI) (Ref. 8)

The objective of the Journey to the land of Eternal Darkness and Ice (JEDI) mission concept would be to explore the lunar polar volatiles. This involves determining the distribution, concentration and origin of hydrogen within the permanently shadowed areas near the lunar poles. The JEDI mission would utilize a mobile platform or rover, as illustrated in Figure 13, to explore the permanently shadowed craters at the lunar pole.

Due to operating within the shadowed regions, the rover was designed to be ASRG powered. It would, however, need to operate in both shadow and while sunlit with a driving range of 20 km. The process for exploring for volatiles would involve auguring to a depth of 1 m with a heated auger tip that can liberate the volatiles from the surface, which would then be collected and analyzed. The science instruments would include a neutron spectrometer, mass spectrometer; laser induced breakdown

spectrometer and an alpha particle X-ray spectrometer. The total mission duration is estimated to be 16 months from launch. The rover and relay satellite are launched together within an Atlas V401. The rover and relay satellite are released and held together for transfer to lunar orbit. Once in lunar orbit the relay is released and the rover descends to the lunar surface. The configuration during the mission timeline is illustrated in Figure 14.

The JEDI rover utilizes a single ASRG to provide power and heat for its 9-month dark crater operations. Over this 9 month period 7 sites would be investigated, 4 in permanent shadow and 3 in partial or full sunlight. The ASRG would be mounted vertically on the rover main deck. This provides clear access for installation prior to launch. The carrier spacecraft through a conductive interface between the ASRG and the spacecraft utilize waste heat from the ASRG. The temperature within the permanently shadowed regions is estimated to be between 40 and 100 K. The effective sink temperature for the ASRG on the surface is estimated to be 209 and 238 K while in transit to the Moon.

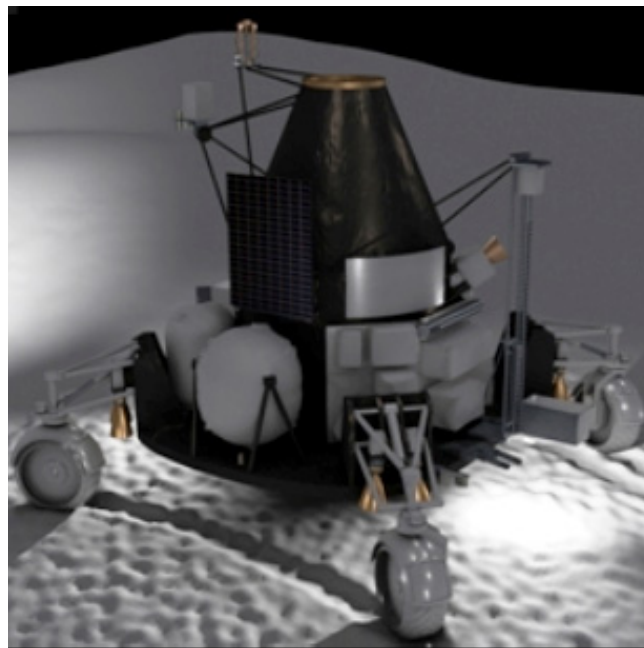

Figure 13.—JEDI Mission Concept Lunar Rover (Ref. 8).

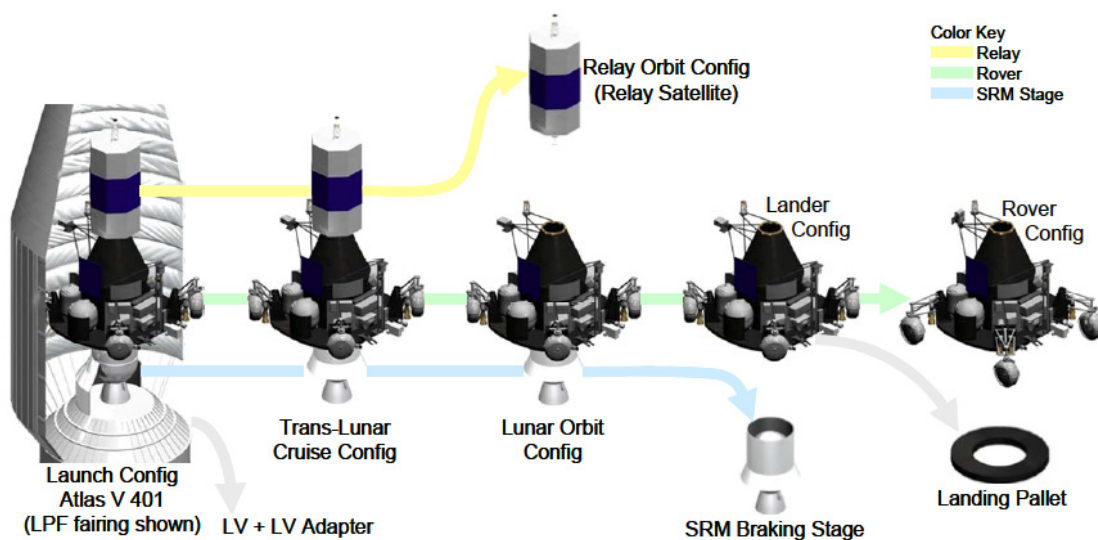

Figure 14.—Rover Configuration at Different Mission Stages (Ref. 8).

TABLE 7.—POWER REQUIREMENTS THROUGHOUT THE JEDI MISSION (REF. 8)

Mission Phase	Launch	Cruise			LOI	Burn	Descent	Surface			
		Rx	Tx					Idle	Rove	Comm	Drill
Power Req (W)	73	223	263	587	688	1160	118	274	174	280	
Operating Time (hr)	2.5	1.0	4.0	0.1	0.5	0.1	1.0	1.0	0.7	1.4	
ASRG Power (W)	71	143	143	143	143	143	145	145	145	145	
ASRG Energy (W-hr)	178	143	570	14	71	14	145	145	102	203	
Battery Energy (W-hr)	4	0	44	44	273	102	0	128	20	189	
Battery DoD	1%	0%	5%	5%	32%	12%	0%	15%	2%	23%	

The power system mass for the ASRG was estimated to be 39.1 kg including a 16 percent contingency. The end of life ASRG power estimate (11 months of operation on the surface) is 145.1 W. A 28 A-hr battery is also utilized to supply supplemental power for the rover during operations. The power requirements throughout the mission are listed in Table 7.

For the JEDI rover either the eight GPHS block STEM-RTG power system or the four GPHS block SRG power system could be a viable candidate to replace the ASRG. This mission duration is much shorter than the estimated 17-year operational time for the STEM-RTG or SRG. Therefore the end of mission output power for both systems is close to the beginning of mission output power. Both the eight block STEM-RTG system and four GPHS block SRG system have an estimated end of the JEDI mission output power of ~200 W, with masses of 29.2 and 32 kg, respectively. Both of these power systems provide similar operating capabilities and mass as the single ASRG systems used in the spacecraft design. Both systems also provide greater output power providing greater power margin for the mission as well as potentially adding additional capabilities to the mission. The increased output power could be used to eliminate one or more strings of the Trans-Lunar solar array and decrease the surface re-charge time and shortening the time needed to complete the baseline mission.

Since the ASRG was mounted on the exterior of the rover any change in volume or the increase in waste heat associated with utilizing either the SRG or STEM-RTG would not have a significant effect on the rover design or layout. Also, as shown in Figure 14, there is ample space surrounding the rover within the faring so any change in dimensions or volume of the power system should not have a significant effect on the launch vehicle.

DSMCE 5: Io Volcano Observer (IVO) (Ref. 9)

The IVO mission concept observe and gather data on Jupiter’s moon Io through a spacecraft in orbit around Jupiter that provides a number of close flybys of Io, as illustrated in Figure 15. The science goals of the mission concept are:

- Understand the eruption mechanisms
- Determine the interior structure
- Investigate the tidal heating mechanisms
- Investigate the tectonics
- Understand the atmosphere and ionosphere
- Investigate the existence of a magnetic field
- Investigate the surface chemistry
- Improve the understanding of the Jupiter system

The proposed mission baseline utilizes 3 Earth flybys and 1 Venus flyby to reach Jupiter, as shown in Figure 16. The transit time to Jupiter is approximately 6.5 years. Once at Jupiter there would be 7 flybys of Io over an 18-month period. The Venus flybys provide the hottest operating conditions for the spacecraft.

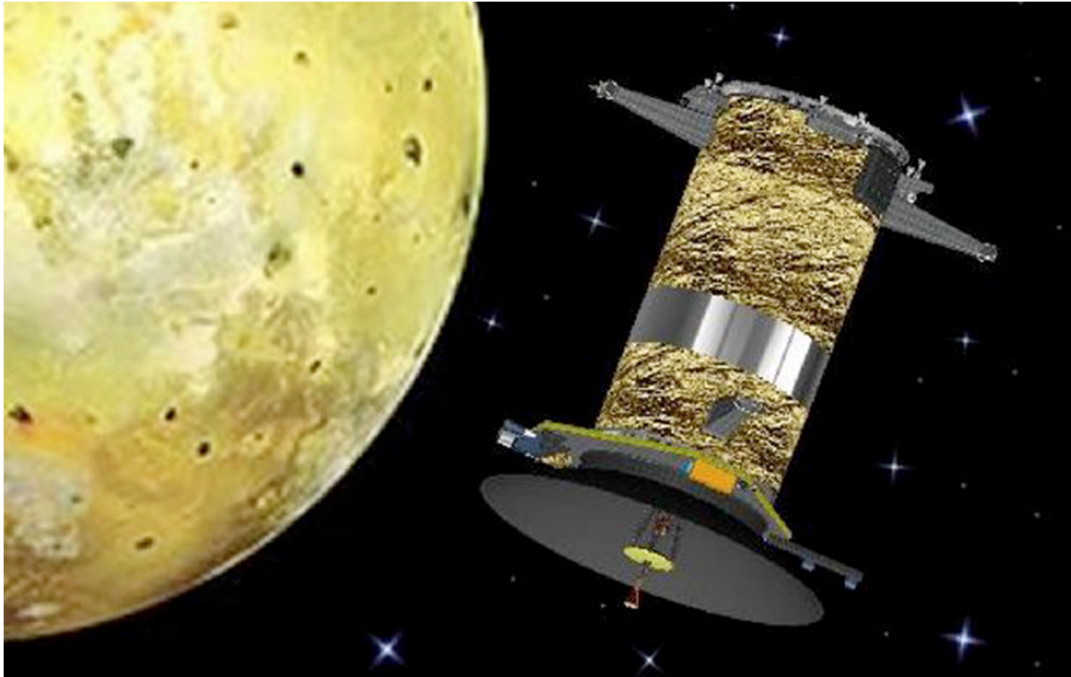

Figure 15.—IVO Spacecraft Concept (Ref. 9).

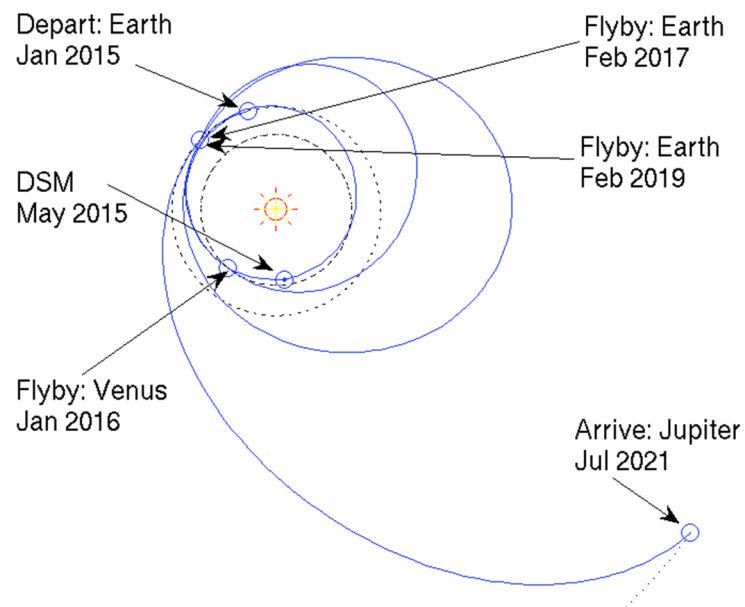

Figure 16.—IVO Orbital Trajectory for Transfer Between Earth and Jupiter (Ref. 9).

When out of range of Io the science instruments would be used to investigate Jupiter and Europa. The science instruments include a narrow-angle camera, thermal mapper, Ion and neutral mass spectrometer, fluxgate magnetometer and possibly a wide angle camera, second ion and neutral mas spectrometer, near IR imaging spectrometer and dust detector. Operating within the Jovian environment exposes the spacecraft to a significant radiation risk. A minimum of 100 kRad tolerant electronics should be utilized for all electrical components within the spacecraft.

The ASRG systems would be utilized in conjunction with a rechargeable Lithium Ion battery to provide power to the spacecraft throughout the mission. The ASRG waste heat is also utilized to maintain the desired internal operating temperature of the spacecraft. The ASRG systems are located internal to the spacecraft structure, below the main propellant tank as illustrated in Figure 17. The mass of the power system was 98.4 kg, with the ASRG system mass estimated at 61.9 kg for 2 systems including a 30 percent contingency. The external spacecraft thermal system is utilized to remove heat from the ASRGs. This system is sized to accommodate the heat load throughout the mission, including operation during the Venus flybys.

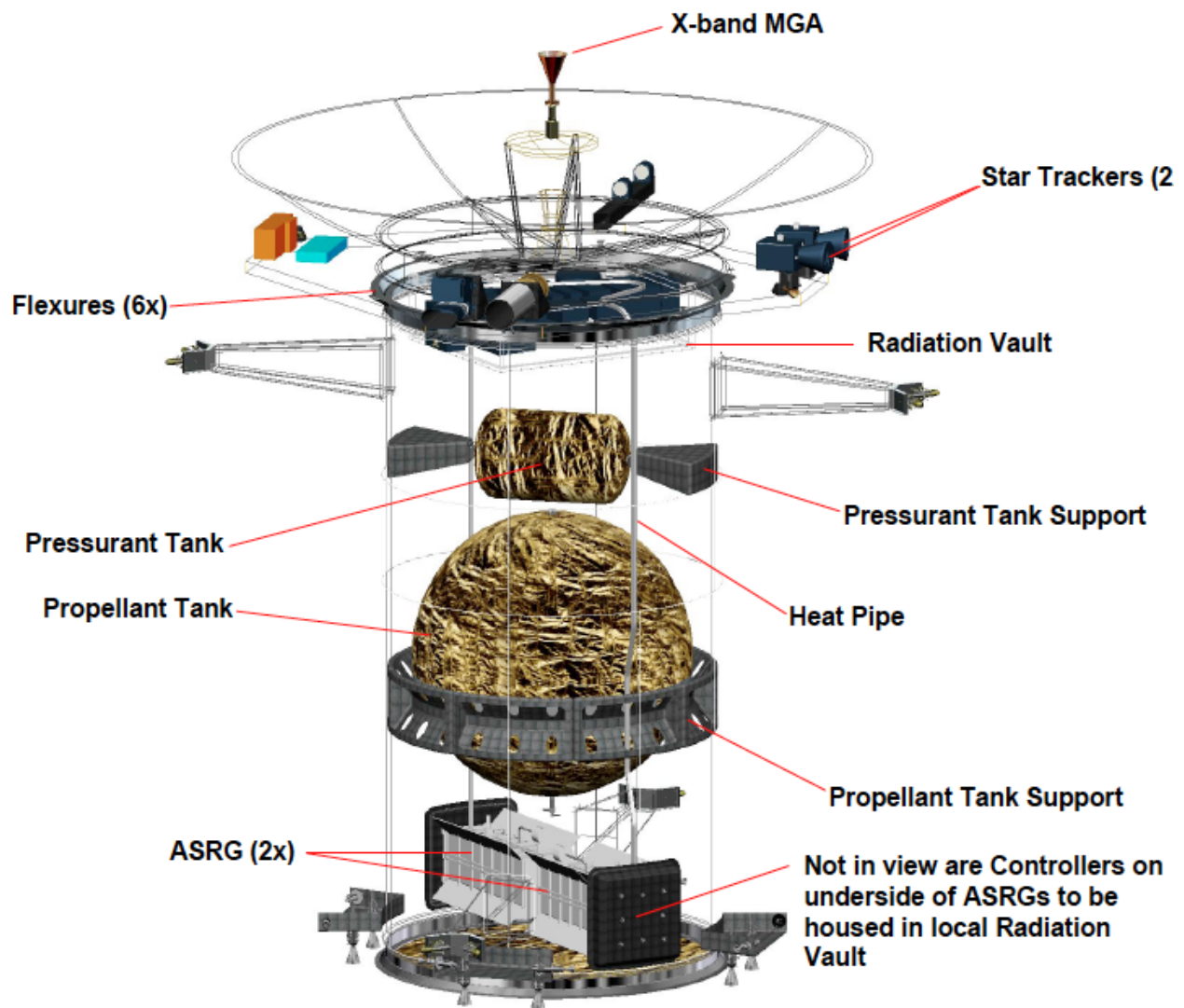

Figure 17.—IVO Concept Spacecraft Internal Component Layout (Ref. 9).

The ASRG systems provided 262 W of power throughout the mission. The Lithium Ion battery provided 2688 W-hr of energy to be utilized to supplement the ASRGs during the mission. The batteries were utilized during the following mission phases along with predicted depth-of-discharge (DoD).

- Safe mode with the transmitter on (DoD, 91.9%)
- Navigation prior to capture (DoD, 92.0%)
- Maneuvering (DoD, 81.2%)
- Science playback mode (DoD, 91.9%)

The advantages of utilizing the ASRG system as the main power source for the spacecraft included the ability to provide a high data rate communications link, spacecraft pointing flexibility and long-term operation. Due to the low solar intensity at Jupiter, approximately 50 W/m², a solar powered mission is difficult requiring a large solar array.

For the IVO spacecraft, either the twelve GPHS block STEM-RTG power system or the six GPHS block SRG power system could be viable candidates to replace the ASRG. The twelve-block STEM-RTG system has an estimated end of mission output power of 255 W with a mass of 42.2 kg. This is lower than the estimated mission power of 262 W, however it is for an end of mission time of 17 years, so based on the IVO mission duration of eight years sufficient power should be available throughout the mission from this system. The six GPHS block SRG has a 266 W estimated end of mission output power and a mass of 46.8 kg. Both of these power systems provide similar operating capabilities and mass as the two ASRG system used in the spacecraft design. Both systems also provide greater output power providing greater power margin for the mission. The main concern is that since the spacecraft design has the ASRG systems located internal to the spacecraft, any change in volume and waste heat generated by utilizing either the SRG or STEM-RTG in place of the ASRG could potentially require a redesign of the spacecraft layout and thermal control system.

DSMCE 6: A DSMCE Trojan Asteroid Lander (Ilion) (Ref. 10)

The Ilion mission concept would rendezvous and ultimately land on a Trojan asteroid and perform science tasks while in orbit and on the surface. The notional spacecraft is shown in Figure 18. The prime target of the mission would be asteroid Nestor. The science objective for the mission is to perform the following tasks:

- Determine the mass, density, and interior structure and configuration of target.
- Determine the surface properties and morphological features of target, including space weathering, maturity and lag deposits
- Determine the mineralogical, elemental and isotopic composition and physical state of volatiles
- Identify and characterize any out-gassing or atmosphere from target Trojan
- Investigate dynamical evolution of target Trojan and search for satellites
- Place Trojan asteroids in context of other bodies

The science instruments that would be utilized to meet the mission goals include the following items.

- Wide angle camera
- Narrow-angle camera
- LIDAR
- Infrared Spectrometer
- Gamma Ray Spectrometer
- Alpha Proton X-Ray Spectrometer
- Laser Desorption Mass Spectrometer
- Neutron Spectrometer

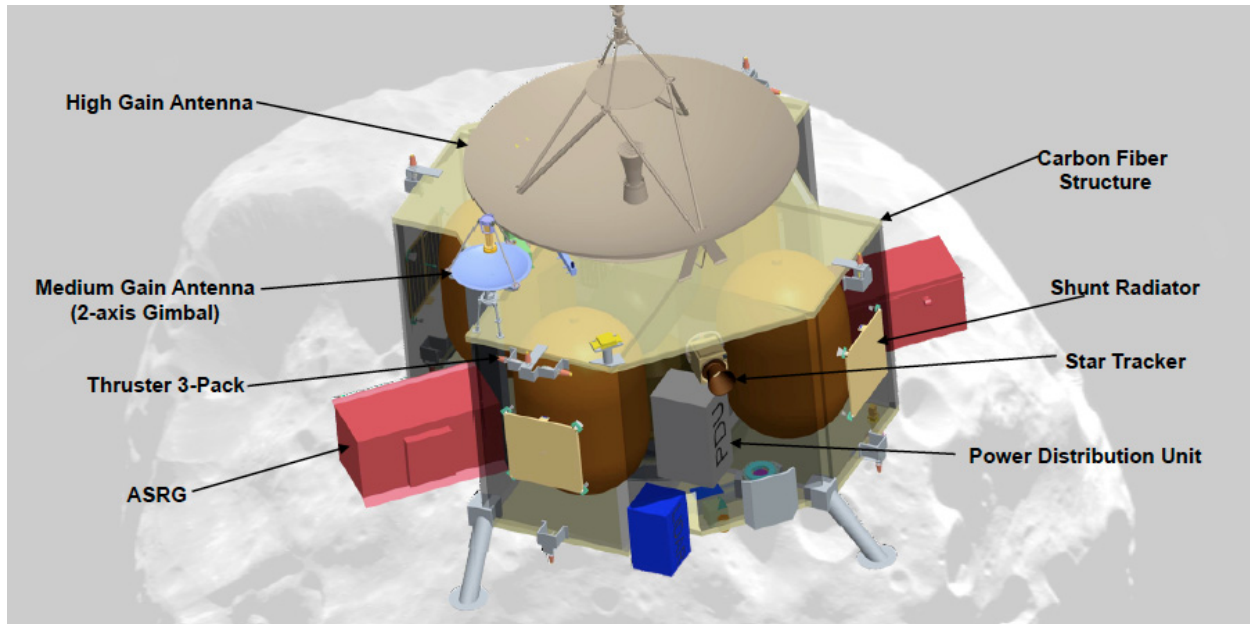

Figure 18.—Ilion Spacecraft/Lander Concept Illustration (Ref. 10).

The total mission time is 11 years, which includes a 10-year cruise period. The spacecraft starts from Earth orbit with a direct transfer to Jupiter’s orbital distance, as illustrated in Figure 19.

The ASRG was selected as the baseline power source for the spacecraft due to the distance from the sun and the need to land the spacecraft onto the surface of the asteroid. A solar array would be prohibitively large, on the order of 90 m² in surface area, especially for meeting the mission requirement to land on the asteroid surface. As shown in Figure 6.1, two ASRGs would be utilized. They are mounted on the exterior of the spacecraft 180° apart. From this orientation, they would be capable of radiating directly to space and would not need any additional thermal interface to reject their waste heat.

The power system design is based on the New Horizons power subsystem with the GPHS-RTG replaced by the ASRG. A diagram of the power system layout is shown in Figure 20. The spacecraft would require 256 W of power at the end of the mission. Therefore, two ASRG systems were utilized to meet this requirement. The power system mass is estimated at 78 kg for both ASRG systems.

For the Ilion spacecraft and lander, either the twelve GPHS block STEM-RTG power system or the six GPHS block SRG power system could be viable candidates to replace the ASRG. The twelve-block STEM-RTG system has an estimated end of mission output power of 255 W with a mass of 42.2 kg and the six GPHS block SRG has a 266 W estimated end of mission output power and a mass of 46.8 kg. This EOM power is sufficient to meet the mission requirements of 256 W EOL. Both of these power systems provide similar operating capabilities and mass as the two ASRG systems used in the spacecraft design.

Both systems also provide greater output power at BOM, thereby providing greater power margin for the majority of the mission. The larger volume and waste heat load of the systems should not have a significant effect on the spacecraft design. Since the majority of the mission occurs in deep space, the added heat rejection would not be a concern. The ASRGs would be mounted on the exterior of the spacecraft and radiate directly to space. This arrangement can also be utilized with either the SRG or the STEM-RTG. Since both the STEM-RTG and SRG are single units that would be replacing two ASRGs, there may be a need to reconfiguration of the layout of the spacecraft to accommodate the new power system geometry. Adjustments to accommodate installation into the launch vehicle should be minimal.

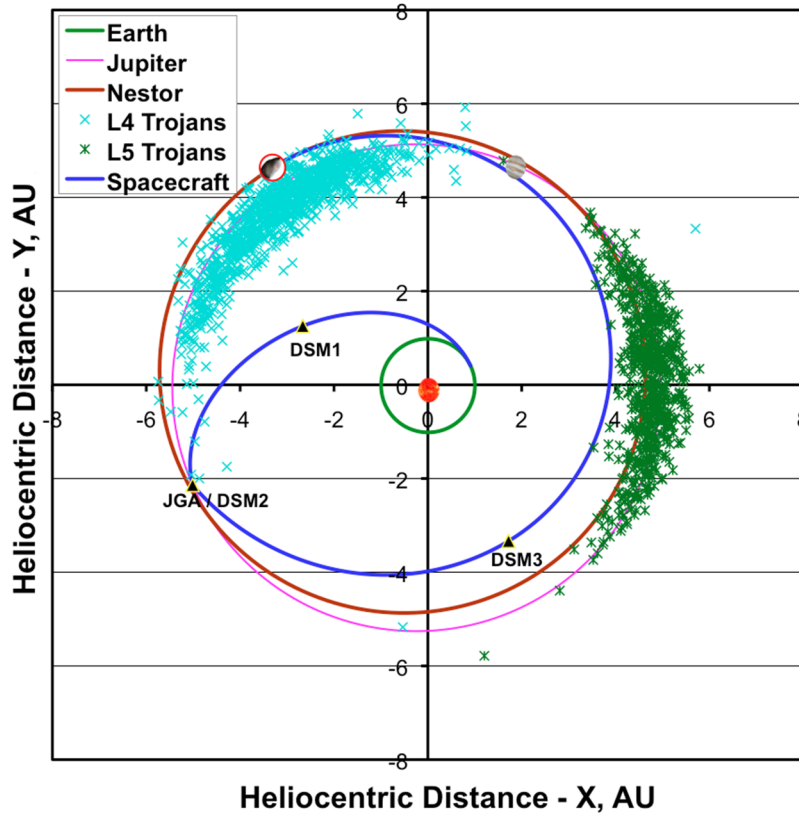

Figure 19.—Iliion Orbital Trajectory (Ref. 10).

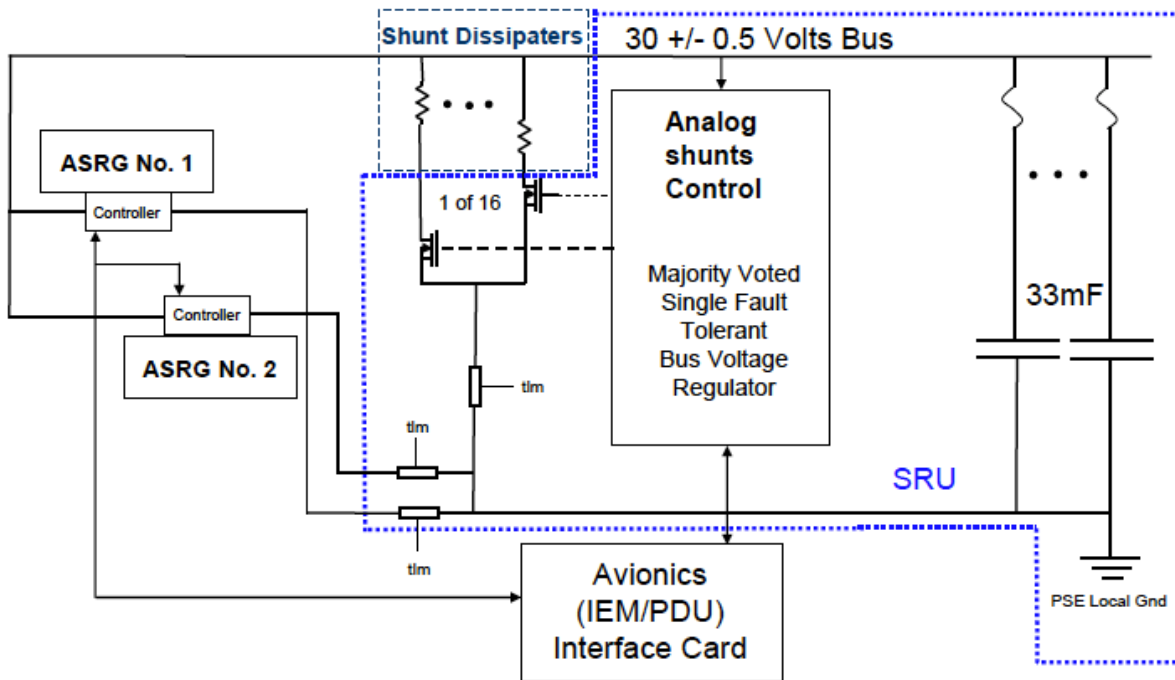

Figure 20.—Iliion Power System Layout Diagram (Ref. 10).

DSMCE 7: Comet Coma Rendezvous Sample Return (CCRSR) (Ref. 11)

The CCRSR mission concept would rendezvous with comet 46P/Wirtanen. The spacecraft conceptual design for this mission is shown in Figure 21. During the rendezvous it would collect dust grains, measure the gases released by the nucleus and photograph the comet from close range. Once the data collection phase is completed, the spacecraft would return to Earth with the collected samples. This mission would be somewhat of a follow-on to the Stardust mission, with the ability to collect more than 1000 times the amount of dust. The ASRG power system was selected for this mission because it enabled long-duration operation within the coma of the comet and does not have pointing requirements, thereby allowing the spacecraft to remain pointed at the comet nucleus throughout the mission. To meet the power requirements of this mission, two ASRGs were required.

The mission was initially projected to launch in November 2015 and return the comet sample to Earth in December 2029, 14 year 1 month mission duration. The notional mission timeline is illustrated in Figure 22.

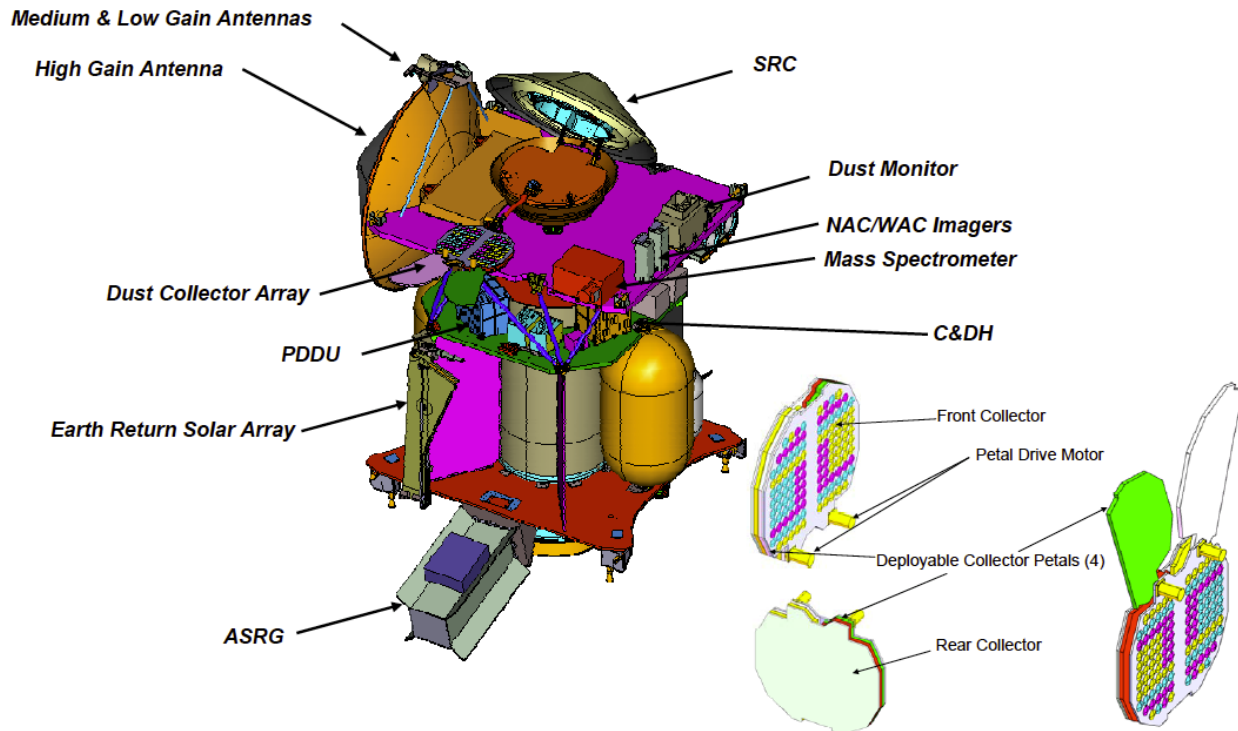

Figure 21.—CCRSR Mission Spacecraft Conceptual Design (Ref. 11).

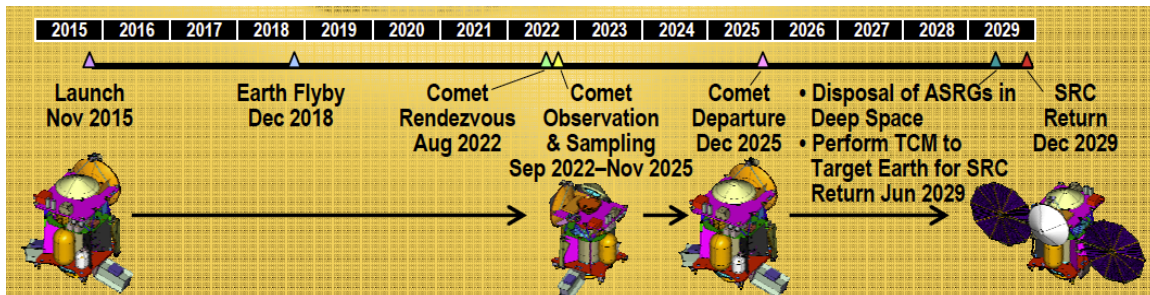

Figure 22.—CCRSR Mission Concept Timeline (Ref. 11).

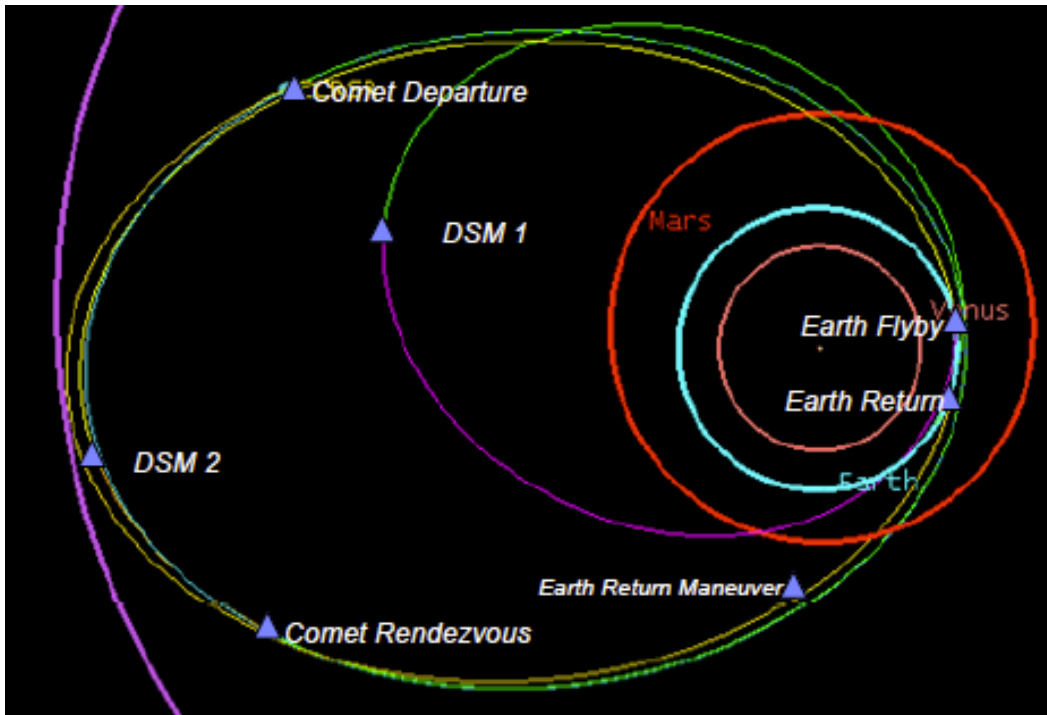

Figure 23.—Orbit Throughout the Mission (Ref. 11).

The proposed mission trajectory from Earth launch to Earth Return is shown in Figure 23. The orbital trajectory does take the spacecraft out past the orbit of Mars and then through an Earth flyby then onto the comet which extends out to nearly the orbit of Jupiter. After co-orbiting with the comet for over three years, it then returns to Earth. Throughout the mission the spacecraft does not come closer to the sun than Earth's orbit (1 AU).

The ASRG system would be disposed of in a non-Earth crossing orbit prior to the sample return portion of the mission. The main science instruments included on the notional spacecraft include a Dust Sample Collector, Neutral-Ion Mass Spectrometer, Narrow and wide angle cameras and dust flux monitor.

The spacecraft would carry both a solar array/battery and ASRG. The ASRG power system is a critical aspect of the mission. It would provide power when the spacecraft is orbiting in close proximity to the comet. During this portion of the mission the solar arrays are not applicable because the gas emanated from the comet would impinge the large surface area of the solar array, causing structural loading, drag and instability on the spacecraft. Also, this dusty environment could degrade the performance of the array and possibly damage it.

For the three phases of the mission (checkout, cruise, sampling), the two ASRG power systems were estimated to provide sufficient power to operate the spacecraft loads with margin, as given in Table 8. The ASRG systems would be mounted external to the primary spacecraft bus, 180° apart, as illustrated in Figure 21. The solar array/battery controller would handle the ASRG shunt power requirements through the solar array/battery control card. If the power load of the spacecraft exceeds the ASRG output capabilities, power would be drawn from the batteries and then subsequently recharged by the ASRG. The ASRG would provide waste heat to the spacecraft to help maintain the internal operating temperature. This waste heat is transferred to the spacecraft through heat pipes. The installation of the ASRG system would occur between 30 days prior to launch to one day before launch (checkout to on-pad radioisotope installation).

TABLE 8.—POWER LOAD & ASRG OUTPUT FOR THE THREE PHASES OF THE CCRSR MISSION CONCEPT (REF. 11)

Mission Phase	Power	Contingency	Total Power	ASRG Output Power	Power Margin
Checkout w Telecom	176 W	15%	202 W	267.9 W	32.6%
Cruise	118 W	14%	135 W	239 W	77%
Sampling	173 W	15%	199 W	253.4 W	27.3%

The allotted electrical power system mass was estimated to be 107.17 kg with a 14.1 percent contingency for a total mass of 122.25 kg.

For the CCRSR spacecraft and mission concept, either the twelve GPHS block STEM-RTG power system or the six GPHS block SRG power system could be viable candidates to replace the ASRG. The twelve GPHS block STEM-RTG system has an estimated end of mission output power of 255 W with a mass of 42.2 kg and the six GPHS block SRG has a 266 W estimated end of mission output power and a mass of 46.8 kg. Both of these power systems provide similar operating capabilities and mass as the two ASRG systems used in the spacecraft design. Both systems also provide greater output power providing greater power margin for the mission. The larger volume and waste heat load of the systems should not have a significant effect on the spacecraft design. Since the majority of the mission occurs in deep space, the added heat rejection would not be a concern. Since both the STEM-RTG and SRG are single units that would be replacing two ASRGs, there may be a need to reconfiguration of the layout of the spacecraft to accommodate the new power system geometry. Adjustments to accommodate installation into the launch vehicle should be minimal.

DSMCE 8: Titan Mare Explorer (TiME) (Ref. 12)

The TiME mission concept would place a floating platform onto the surface of a Titan methane lake to provide science data on the Titan environment. The science objectives included looking at the methane lake chemistry, determine the lake depth, determine the physical properties of the lake, examine the local meteorology and it's on the methane cycle and examine the morphology of the lake surface and shoreline. These objectives are accomplished through a series of science instruments, which include; mass spectrometer, Sonar, meteorological instruments (Temperature, Pressure, Humidity, Wind Speed), composition instruments (refractive index, dielectric constant) and imaging cameras (descent and surface). The power consumption of the science instruments was estimated to be 91 W, including contingency power. There is some concern that the heat rejected from the ASRG systems would affect the measurements of the science instruments. Additional study and modeling would be needed to confirm this and correct for any influence when processing the data.

The TiME lander would be 3.0 m in diameter and is a 2X scale of the Genesis design. The TiME lander concept is illustrated in Figure 24. The backshell of the lander has a hatch that would allow the ASRG to be installed just prior to launch. The ASRG would be installed into the ASRG Environment Enclosure (AEE) within the lander as illustrated in Figure 25. This enclosure provides a buffer between the waste heat generated by the ASRG and the interior of the lander thereby maintaining the desired temperature distribution within the lander.

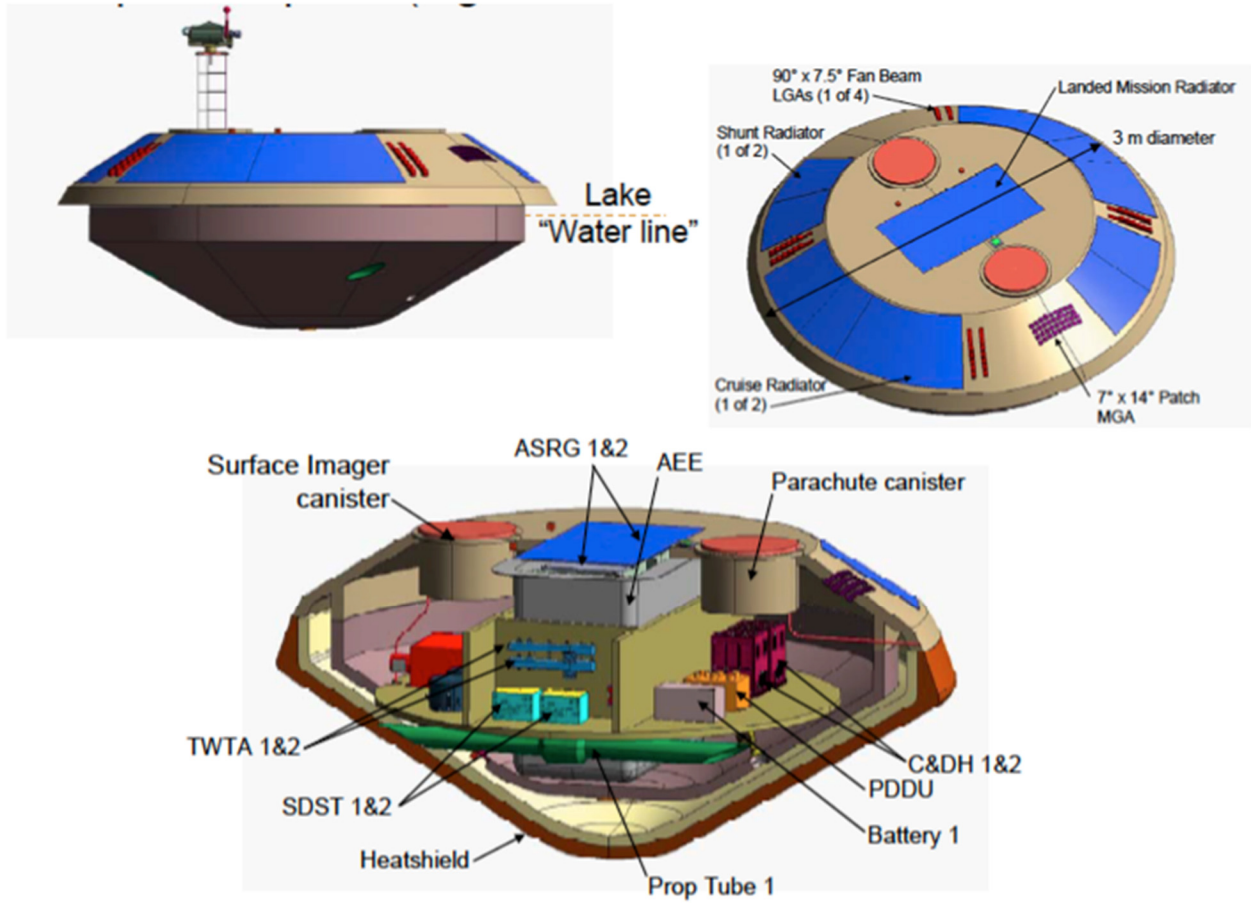

Figure 24.—TiME Mission Lander Concept (Ref. 12).



Figure 25.—ASRG Location Within the Lander (Ref. 12).

The mission duration from launch to end of mission was approximately eight years. The notional mission timeline is given in Figure 26. The orbital trajectory utilizes an Earth flyby in transit to Saturn as shown in Figure 27.

The ASRG power system was a critical element to the floating lander design and mission feasibility. Due to the low solar intensity on the surface of Titan, approximately 1.5 W/m^2 , a radioisotope system would be required as the power system for a long duration mission in this environment. Radioisotope power also eliminates landing orientation requirements and changes in output power with attitude changes. Two ASRG systems are utilized in the design to provide power to the lander. The ASRGs would be located at the top of the lander, as illustrated in Figure 8, underneath a radiator panel used for rejecting the waste heat during both transit in space and while on the Titan surface. Heat would be moved from the ASRG to the radiator through constant conductance heat pipes. Other options to this arrangement are also under consideration, such as a combined fin, heat-pipe radiation combination or a fin only heat rejection. These options may provide increased thermal and power system performance margins. In addition to enabling easy waste heat rejection, the ASRG mounted location in the center of the lake lander was done to optimize its center of mass. During transit there are 2 additional radiators that are utilized to reject heat from the ASRGs as well as 2 shunt radiators to shunt any excess power generated and reject it as heat.

The ASRGs operate in conjunction with a battery. If power above the output of the ASRGs would be required, the batteries supply the difference, such as during communications transmission. And when power requirements are below what can be supplied by the ASRG, the excess power would be used to charge the batteries. The EOM output power requirement for the ASRG systems is 242.6 W with contingency and margin.

Mission Schedule



Figure 26.—TiME Mission Schedule (Ref. 12).

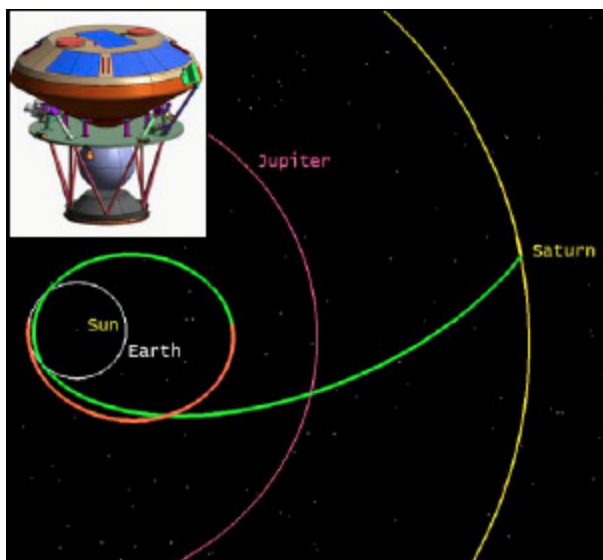

Figure 27.—TiME Mission Concept Orbital Trajectory (Ref. 12).

For the TiME lander and mission, either the twelve GPHS block STEM-RTG power system or the six GPHS block SRG power system could be viable candidates to replace the ASRG. The twelve-block STEM-RTG system has an estimated end of mission output power of 255 W with a mass of 42.2 kg and the six GPHS block SRG has a 266 W estimated end of mission output power and a mass of 46.8 kg. Both of these power systems provide similar operating capabilities and mass as the two ASRG systems used in the spacecraft design. Both systems also provide greater output power providing greater power margin for the mission. The main concern with this system would be the added waste heat generated by the increased number of GPHS blocks. This increase in waste heat would need to be accounted for in a revised thermal design. This would increase the size of the radiators needed both during cruise as well as on the surface of Titan. It would also require additional internal insulation surrounding the AEE to maintain the correct operating temperature within the lander. The effects of the added waste heat as well as the larger size of the STEM-RTG or SRG compared to the ASRG would likely cause an increase in the size of the lander or a repackaging of the components within the lander to accommodate the larger size such as a transverse mounting scheme. Since the mass between the systems is similar, the positioning of the alternate systems would be similar to that for the ASRG.

DSMCE 9: Comet Hopper (CHopper) (Ref. 13)

The Comet Hopper (CHopper) mission concept would rendezvous with comet 46P/Wirtanen and enter a co-orbit with it around the sun. The comet orbit varies from approximately 5 AU to 1 AU, as illustrated in Figure 28.

The mission would have two phases; a remote mapping portion and a surface science portion. Once in co-orbit with the comet, the spacecraft would perform its remote science portion of the mission. Once this portion is completed, it would then land on the surface to begin the surface science portion of the mission. The lander would have the capability to move or hop to multiple locations on the surface. Two hops would be performed to explore a total of three surface locations.

The main science goals of the CHopper mission would be to determine the composition and morphologic heterogeneity of the comet, determine the processes that drive comet evolution and variation in comet types and examine the physical structure of the comet. The main science instruments include;

- Gas Mass Spectrometer
- Multi-Spectrometer Imager
- IR Spectrometer
- APXS,
- Thermal Probe
- Panoramic Cameras

The mission duration would be 8.5 years including a 6.5-year cruise to the comet location and 2-year science data-gathering portion.

The ASRG was selected for this mission concept due to the need to operate at the 5 AU distance from the sun. At this distance, solar power would not be a viable power source for the spacecraft. Also, the requirement to land on the surface and hop to other locations would put significant structural loading on a solar array, as well as require it to operate within a dusty environment.

The CHopper spacecraft utilized two ASRGs to provide power throughout the mission. A set of redundant 30 A-Hr batteries would also be utilized to provide power to meet peak demand loads. The power requirements throughout the mission are listed in Table 9.

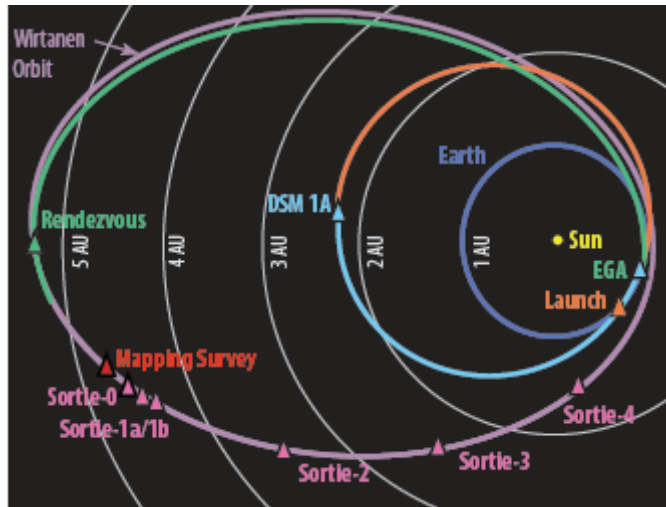

Figure 28.—CHopper Mission Concept Orbit (Ref. 13).

TABLE 9.—CHOPPER MISSION CONCEPT POWER REQUIREMENTS (REF. 13)

Mission	Post comet arrival	Mapping-MEV (Science/Overall)	Sortie 1B-MEV (Science/Overall)
Total Required Power	187.5 W	207.6/226.4 W	172.8/206.4 W
ASRG Power Output	246.7 W	244.5 W	240.9 W
Battery DoD	22%	34%	32%
Power Margin	46%	33%	53%

Although the average power consumption during the phases (listed below) is below that available from the ASRGs, the predicted power consumption profile had power levels above the ASRG output level; this therefore required batteries to make up this difference. The power profiles are shown in Figures 29 and 30 for the mapping phase and sortie, respectively.

Waste heat from the ASRG's control units would be utilized to heat components within the spacecraft such as the hydrazine tanks. The two ASRGs would be positioned on the exterior of the spacecraft, as shown in Figure 31, where they can radiate directly to space without the need for a thermal interface system to reject their waste heat.

For the CHopper spacecraft and mission concept, either the twelve GPHS block STEM-RTG power system or the six GPHS block SRG power system could be viable candidates to replace the ASRG. The twelve-block STEM-RTG system has an estimated end of mission output power of 255 W with a mass of 42.2 kg and the six GPHS block SRG has a 266 W estimated end of mission output power and a mass of 46.8 kg. Both of these power systems provide similar operating capabilities and mass as the two ASRG systems used in the spacecraft design. Both systems also provide greater output power providing greater power margin for the mission or reduced battery usage. Since the ASRG systems are mounted on the exterior of the spacecraft the use of either the STEM-RTG or SRG should not require significant modifications to the thermal system design. The added size of these systems would need to be accounted for, but based on the layout shown in Figure 31, this should not be a significant impact. Also the mass between the systems is similar, therefore the positioning of the alternate systems would be similar to that for the ASRG.

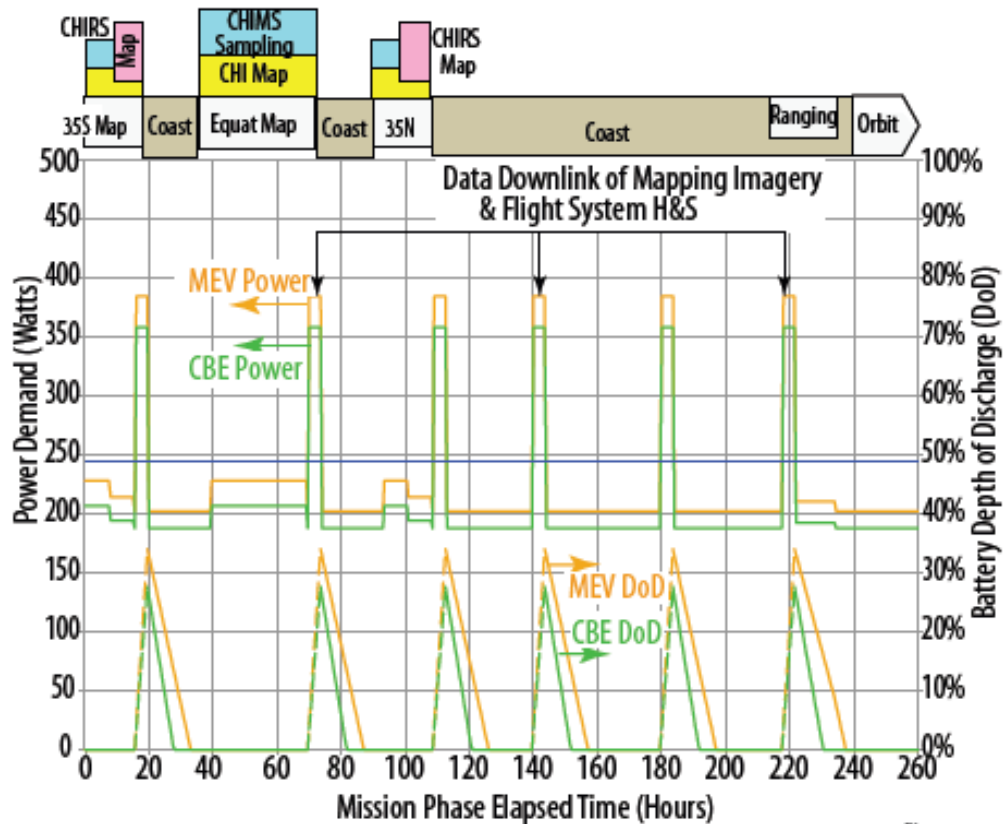

Figure 29.—CHopper Mapping Phase Power Profile (Ref. 13).

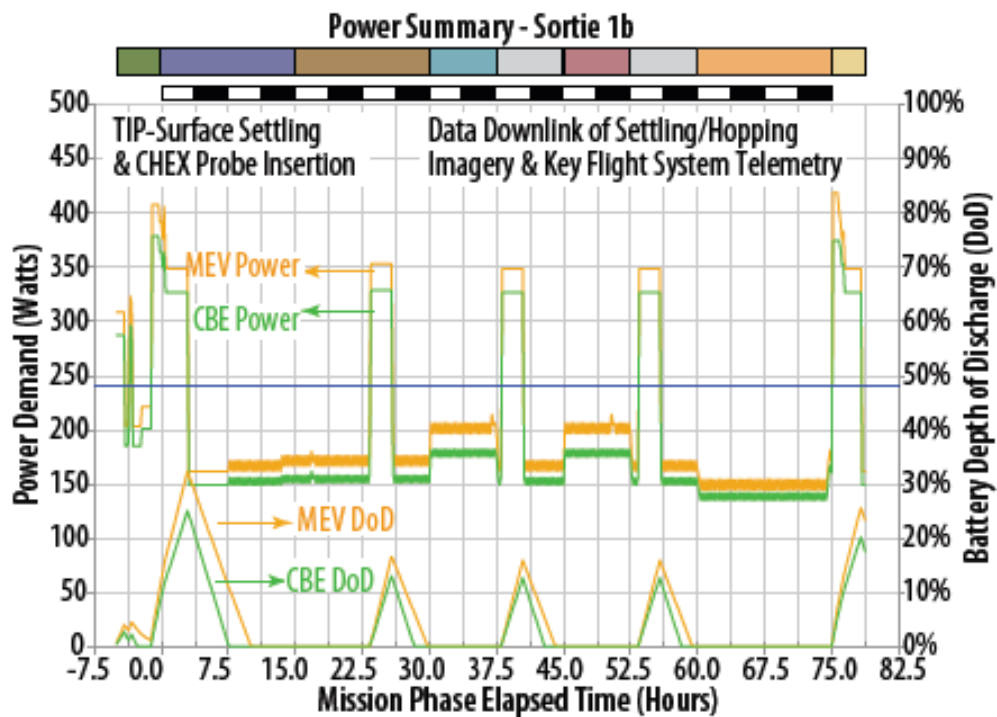

Figure 30.—Sortie Phase Power Profile (Ref. 13).

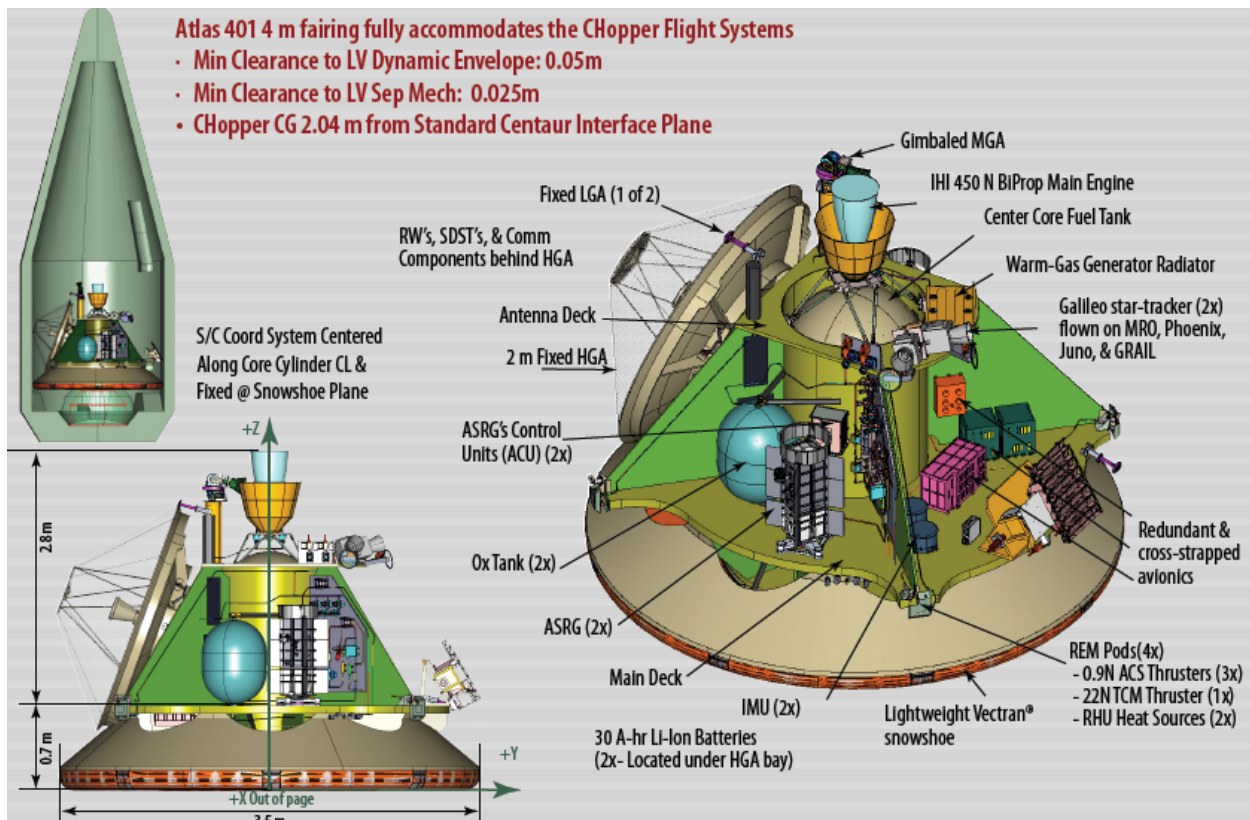

Figure 31.—Position of the ASRGs on the Exterior of the CHopper Spacecraft (Ref. 13).

Summary

A overview of the nine missions identified as candidates for utilizing the ASRG power system was presented in the previous sections. By considering the operational environment for each mission concept as well as the power level, vehicle configuration, and operational requirements, an assessment was made as to the potential applicability of the STEM-RTG or SRG to provide power for these missions. Versions of the STEM-RTG and SRG systems have similar output power levels to either single or multiple ASRG power systems. All of the mission concepts considered were limited to a maximum of utilizing two ASRG power systems, although some missions only utilized one ASRG system. The twelve block STEM-RTG system and the six block SRG system provided comparable output power to a two ASRG system, whereas an eight block STEM-RTG system and a four block SRG system was comparable to a single ASRG system.

The utilization of an STEM-RTG or SRG system in the identified mission concepts depends on how easily they could be substituted for the ASRG system(s). This generally means minimizing any changes to the vehicle configuration or design or mission goals and objectives. Some of the main items to consider include:

- Ease of waste heat rejection: Since the STEM-RTG and SRG systems would utilize more GPHS blocks than the ASRG system there would be additional heat to reject and also supply additional heat if required by the mission.
- Installation mass: Since a single STEM-RTG or SRG would be replacing two ASRGs, in a number of the mission, the placement and mass of the STEM-RTG or SRG has to be consider. Total mass as well as center of mass changes to the spacecraft has to be considered.

- Installation Volume: Since a single STEM-RTG or SRG would be larger than a single ASRG this increased volume must also be considered for vehicles utilizing a single ASRG.
- The output power of the identified STEM-RTG and SRG systems would be higher throughout their mission lifetime than the comparable ASRG system. Therefore the ability to meet the output power requirements for the missions with the substituted systems should not be a problem.

To aid in evaluating the applicability of either the STEM-RTG or SRG systems in replacing the ASRG power system for the nine mission concepts examined, a 1 to 10 scale (1 corresponding to no impact to 10 corresponding to major impact) is utilized. The scale identifies the perceived impact on the spacecraft of substituting the STEM-RTG or SRG for the ASRG regarding the identified areas of thermal control, mass distribution and volume constraint. This rating is given in Table 10.

Based on the ratings shown in Table 10, the two lunar surface missions, DSMCE 2: EXOMOON and DSMCE 4: JEDI, would be the most applicable to integrating the STEM-RTG or SRG power systems. These mission concepts minimize the integration concerns with utilizing these power systems in place of the ASRG. This is because for those missions only one ASRG system would have been utilized. Therefore using either the STEM-RTG or SRG would be close to a 1 to 1 replacement. For the other missions that utilized two ASRGs, these would be replaced by a single STEM-RTG or SRG. This can cause mass distribution concerns as well as volume concerns with the power system shifted from two locations to a single location. Another advantage to these lunar missions is that the power system would be located on the exterior of the vehicle. This allows it to reject heat directly from its radiators. This arrangement would also allow the STEM-RTG or SRG to also radiate directly to space to reject their waste heat without any modification to the spacecraft or power system. The final advantage is that the power system would be exposed to space during transit to the moon. This also allows the system to reject heat without any modification to the spacecraft.

The least applicable mission concepts were ones that utilized multiple ASRG systems and had them located within the spacecraft or surface vehicle. This configuration could likely require significant modification to the design to accommodate the increased waste heat load of the STEM-RTG or SRG.

TABLE 10.—STEM-RTG & SRG IMPACT OF REPLACING ASRG POWER SYSTEM

Mission	System	Thermal impact	Mass and distribution impact	Volume impact	Total impact
DSMCE 1: Venus Atmospheric Long-Duration Observatory for in situ Research (VALOR)	STEM-RTG	7	1	2	10
	SRG	5	1	2	8
DSMCE 2: Lunar Lander (EXOMOON)	STEM-RTG	2	1	2	5
	SRG	2	1	2	5
DSMCE 3: Mars Polar Ice Borehole (Kuklos)	STEM-RTG	2	7	5	14
	SRG	2	8	4	14
DSMCE 4: Lunar Polar Volatile Explorer (JEDI)	STEM-RTG	2	1	2	5
	SRG	2	1	2	5
DSMCE 5: Io Volcano Observer (IVO)	STEM-RTG	9	2	3	14
	SRG	7	2	5	14
DSMCE 6: Trojan Asteroid Lander (Ilion)	STEM-RTG	2	7	5	14
	SRG	2	8	4	14
DSMCE 7: Comet Coma Rendezvous Sample Return (CCRSR)	STEM-RTG	2	4	5	11
	SRG	2	5	4	11
DSMCE 8: Titan Mare Explorer (TiME)	STEM-RTG	8	2	4	14
	SRG	6	2	3	11
DSMCE 9: Comet Hopper (CHopper)	STEM-RTG	2	4	3	9
	SRG	2	5	3	10

Conclusions

One observation of this assessment of the applicability of the new RPS designs to the nine DSMCE missions is that, at a minimum, these missions could utilize a new RPS with a designed EOM power output in the 300 We range. And to a varying degree, some sort of spacecraft accommodation could be required to implement any of the new concepts. Furthermore, the more tightly coupled or integrated the power system would be with other spacecraft systems, e.g., thermal, the more difficult this would become. Without a redesign starting with a “clean sheet of paper,” it is difficult to determine to what degree a new RPS would benefit the design. It is not unreasonable to expect that a spacecraft design could make use of a single higher power unit as its power system option. Unfortunately, a redesign effort with each of the nine DSMCE teams is not practical or prudent at this time.

NPAS assessed Discovery, New Frontiers and Flagship missions for their power needs and determined that if a new RPS development were to occur, a system producing about 300 We after ~15 years (three years storage, 12-year mission) to support an outer planet mission’s typical trip time, could support all three SMD-type missions with a single or multiple number of units.

Recommendations

The power range common for New Frontiers missions is on the order of 500 to 600 We EOM. The use of small, 100 to 130 We units to supply this power level creates potential issues with integration with other spacecraft systems and launch vehicle integration logistics at the launch site. A follow-on study is recommended for a similar effort done here for Discovery class missions to be performed for the appropriate missions enabled by RPS, that have been identified in the two Decadal surveys and, in particular, the mission concept set announced for the NF-4 AO.

References

1. NASA Facts: Advanced Stirling Radioisotope Generator (ASRG), NF-2013-07-568-HQ, 2013.
2. “Space and Defense Power Systems,” U.S. Department of Energy, www.ne.doe.gov, October 2011.
3. Fleuriel, J-P, Schmitz, P, Mason, L., “RPS for Team-X and ACE UOP TSSM Study,” Draft, 6-9-14.
4. Mitchell, B., “NASA Discovery Program,” website: discovery.nasa.gov, March 2015.
5. Baines K.H. (PI) and Balint, T.S., “Nuclear Polar VALOR (Venus Atmospheric Long-Duration Observatory for in suit Research),” Final Report, February 23, 2009.
6. Elphic, R.C., Lawrence, D.J., Weinberg, J.D, Deans, M., Delory, G.T., Dissly, R., Evanyo, J., Fong, T., Grimes, J., Heldmann, J., Hurley, D., Lucey, P.G., Pedersen, L., Riesco, M., Smith, T., Taylor, G.J., Vondrak, R., Waite, H., Yachbes, I., Zacny, K., “ExoMoon, A Discovery and Scout Mission Capability Expansion Concept,” Final Report, NNH09CE34C, October 2, 2009.
7. Hecht, M., Warwick, R., Benardini, J., Hurst, K., Johnson, M., Smith, M., Spry, A., Zumwalt, L., “Discovery and Scout Mission Capabilities Expansion: A Tour Through Martian History: An ASRG-Powered Polar Ice Borehole (Kuklos),” Final Report, March 2008.
8. Jolliff, B. (PI), “JEDI-Journey to the land of Eternal Darkness and Ice: A Lunar Polar Volatile Explorer,” Final Report, NNX08AP38G, January 31, 2009.
9. McEwen, A.S. (PI), Final DSMCE Report, “Mission Concept: Io Volcano Observer (IVO),” February 23, 2009.
10. Rivkin A.S. (PI), Gold, R.E., Paul, M.V. and Dankanich, J., “Ilion: An ASRG-Enabled Trojan Asteroid Mission,” Final Report, SDO-12140, February 23, 2009.
11. Sandford, S. (PI), “Comet Coma Rendezvous Sample Return (CCRSR),” Final Report, NNA08BB99C, February 20, 2009.
12. Stofan, E (PI), “Titan Mare Explorer (TiME),” Final Report, February 23, 2009.
13. Sunshine, J. (PI), “Comet Hopper (CHopper),” Final Report, AO-NNH10ZDA0070, March 2012.

